

Evaluation of TCSC Power flow control Capability

Shivani Choudhary

Oriental Institute of Science & Technology, RGPV University

Oriental Campus, Thakral Nagar, Raisen Road, Bhopal(M.P.)

E-mail:shivani.choudhary28@Gmail.com

Samina.E.Mubeen

Radharaman Engineering College, RGPV University

Bhadbhada Road, Ratibad, Bhopal (M.P.)

Monika Jain

Oriental Institute of Science & Technology, RGPV University

Oriental Campus, Thakral Nagar, Raisen Road, Bhopal (M.P.)

E-mail:shivani.choudhary28@Gmail.com

Abstract

In an A.C Transmission system power flow can be controlled by injecting a compensating voltage in series with the line. Thyristor Controlled series compensators (TCSC) are utilized as a conventional means for the purpose. This paper utilizes the steady state model of Thyristor controlled series capacitor and a unified power flow controller for series voltage compensation, and evaluating their range of power flow control for simple network. The models are incorporated into the existing Newton Raphson load flow algorithm. The iterative equations of the Newton Raphson load flow algorithm are modified by the device parameters and the combined set of power flow equations and the TCSC control equations are solved for convergence of the formula. Matlab codes are utilized for the implementation of the devices in the Newton-Raphson algorithm. Power flow control ranges are evaluated for standard 5 bus system. Results are reported and studies are presented to illustrate the power flow capabilities of TCSC.

Keywords: Converters, Control Strategy, MATLAB, Newton Raphson algorithm, Power flow, TCSC

I. Introduction

OWING to the higher industrial demands and deregulation of the power supply industry the transmission facilities are being overused. This provides the momentum for exploring new ways of maximizing the power transfers of existing transmission facilities while, at the same time, maintaining acceptable levels of network reliability and stability. This scenario makes necessary the development of high performance control of the power network. Recent advancement in power electronics has proven to satisfy this need by introducing the concept of flexible AC transmission system (FACTS). The FACTS controllers are used in regulating the power flows, transmission voltages and mitigate the dynamic disturbance.

Since its inception the FACTS devices has developed in steps, the first generation being mechanically controlled capacitors and inductors. The second generation of FACTS devices replaced the mechanical switches by the thyristor valve control. This gave a marked improvement in the speed and the enhancement in concept to mitigate the disturbances.

Power flow in a transmission line can be controlled by regulating the voltage at the two ends of the line, the phase angle or the reactance of the line. Thyristor controlled series compensators works on the principal of regulating the voltage of the transmission line by injecting voltage employing capacitor or inductor. In order to fully investigate the impact of this device on power system effectively, it is essential to formulate their correct and appropriate model. Generally there are three types of model of FACTS devices available in the literature.

- (i) Steady state model for system study state evaluation.
- (ii) Electromagnetic model for detailed equipment level investigation.
- (iii) Dynamic models for stability studies.

This paper deals with the steady state models of TCSC [6] which can be incorporated in Newton Raphson load flow algorithm.

II. Power Flow control

In its most basic form the power transmission line can be represented by a two bus system k, m. The active

power transmitted between bus nodes k and m is given by $P = \frac{|V_k| |V_m|}{X_l} \sin(\delta_k - \delta_m)$ where V_k and V_m

are the voltages at the nodes, $(\delta_k - \delta_m)$ the angle between the voltages and X_l the line impedance. The power flow can be controlled by altering the voltages at a node, the impedance between the nodes and the angle between the end voltages. The reactive power is given by.

$$Q = \frac{|V_k|^2}{X_l} - \frac{|V_k| |V_m|}{X_l} \cos(\delta_k - \delta_m)$$

A. Thyristor Controlled Series Compensator (TCSC)

The power flow model of Thyristor controlled series compensator is based on the concept of variable series reactance, the value of which is adjusted to control the power flow. The variable reactance model is represented by X_T (equivalent reactance) connected in series to the transmission line between the buses k, m. The variable reactance develops a compensating voltage (reactive) which is a function of line current.

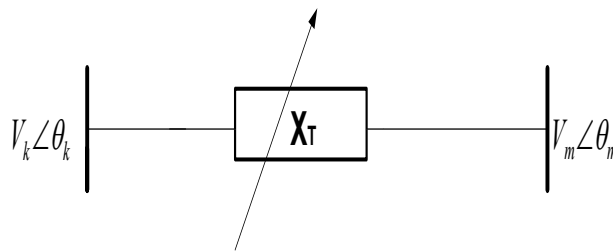

Fig 1. TCSC equivalent circuit

TCSC does not exchange real power with the AC system (except for losses) [9]. It only generates or absorbs the reactive power required for compensation by the capacitor or reactor banks and the thyristor switch are used to control only the combined reactive impedance these present to the AC system.

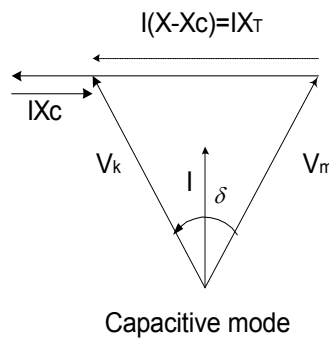

Fig 2. Control Mode of TCSC.

The Power flow equations of TCSC can be written as

$$P_k = V_k V_m B_{km} \sin(\theta_k - \theta_m) \quad (6)$$

$$Q_k = -V_k^2 B_{kk} - V_k V_m B_{km} \cos(\theta_k - \theta_m) \quad (7)$$

where

$$B_{km} = \frac{1}{X_T}, B_{kk} = -\frac{1}{X_T} \text{ where } X_T \text{ is the equivalent reactance of the TCSC. In general form [10]}$$

$$P = f_2(V, \theta, B) \tag{8}$$

$$Q = g_2(V, \theta, B) \tag{9}$$

III. Implementation Of TCSC Models In Newton Raphson Power Flow Algorithm.

The TCSC power equations are combined with the network equations and linearised with respect to the state variables. The linearized power flow equations can be represented as $[F(X)] = [J] [\Delta X]$ where $[F(X)]$ is power flow mismatch vector, $[J]$ is the Jacobian matrix; $[\Delta X]$ is the state variable correction vector [1]. The device parameters are used as state variable. For the TCSC the variable reactance is taken as state variable. The inclusion of these variables increases the dimension of the jacobian.

A. Newton Raphson Power Flow Algorithm with TCSC

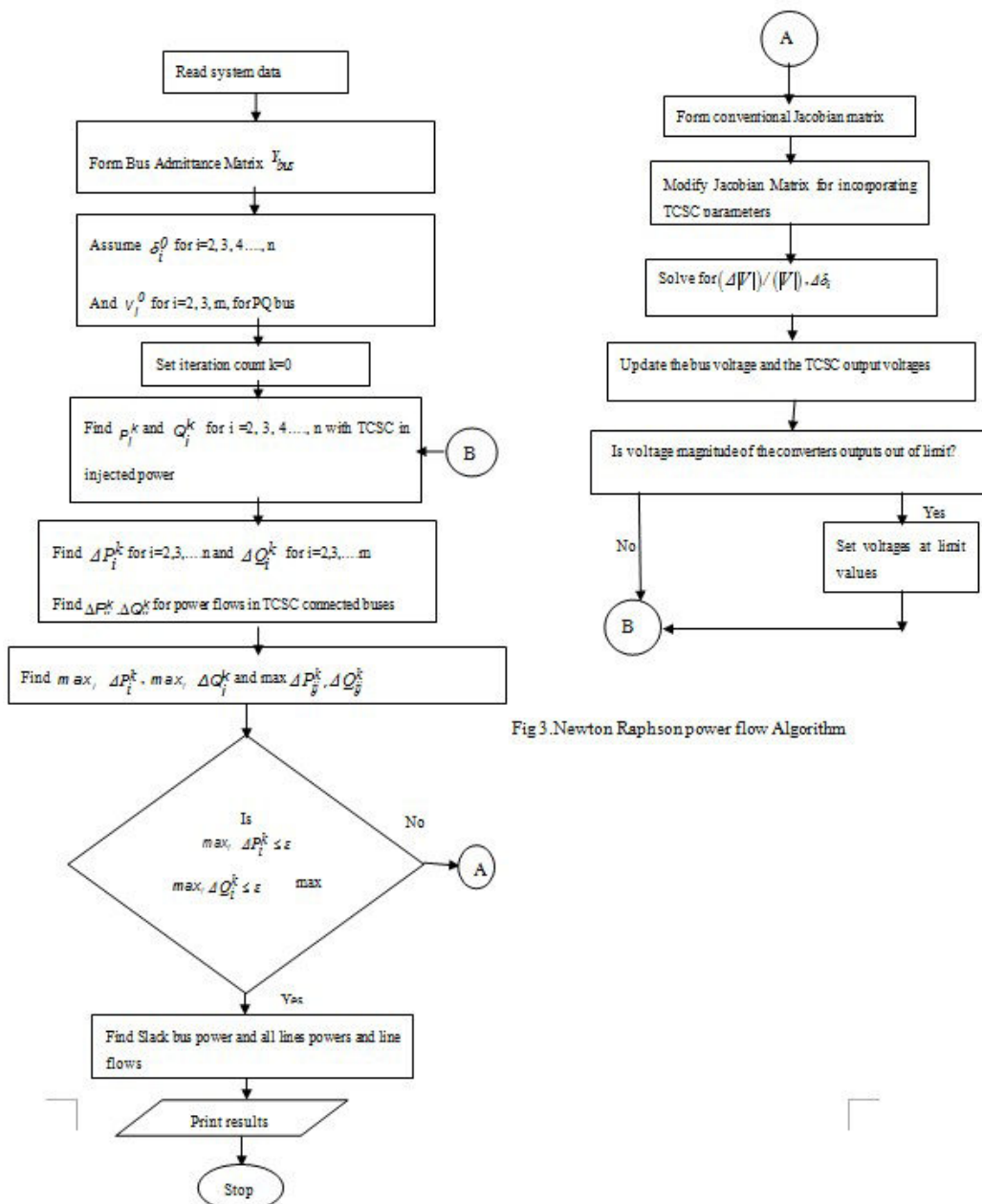

Fig 3. Newton Raphson power flow Algorithm

B. Control Strategy

For the TCSC variable series reactance is taken as the state variables. This reactance is adjusted in the Newton Raphson algorithm at each iteration automatically along with the network state variables to achieve the specified power and voltage. The variable reactance X_T in the fig 3 and 4 represents the equivalent reactance of all the series connected modules making up the TCSC, when operating in either the inductive or the capacitive regions.

IV. Test Case and Simulation

Standard 5 bus test network is tested without TCSC and with TCSC, to investigate the behavior of the two devices in the network. In the analysis bus 1 is taken as slack bus, 2 and 3 are voltage control buses and 4, 5 are load buses. To include the TCSC in the network an additional bus (bus no 6) is introduced as shown. For TCSC the inductive reactance is taken 0.015 pu. The TCSC is implemented as variable series reactance model for power flow control. The series reactance is taken as state variable and its value is adjusted automatically to obtain specified power which was taken as 0.19 pu. For the TCSC the convergence was obtained at 9 iterations. The simulation yields the power flow for lines and bus active and reactive powers which are tabulated below.

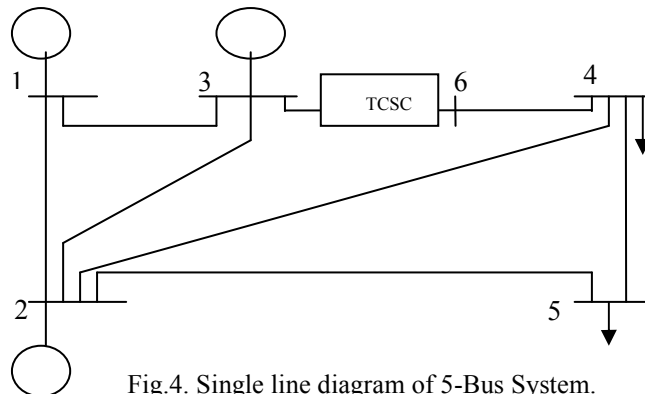

Fig.4. Single line diagram of 5-Bus System.

Test Data is given in Tables below

TABLE I - BUS DATA

Bus no.	Voltage ($ v , \theta$) pu	Load (MW, Mvar) pu	Generator		Injected MVAR
			(MW, Mvar) pu	Qmin, Qmax x pu	
1	1.06, 0	0, 0	0, 0	10, 50	0
2	1.045, 0	20, 10	40, 30	10, 50	0
3	1.03, 0	20, 15	30, 10	10, 40	0
4	1.00, 0	50, 30	0, 0	0, 0	0
5	1.00, 0	60, 40	0, 0	0, 0	0

TABLE II- LINE DATA

Sending Bus	Receiving Bus	Line resistance pu	Line reactance pu	Line susceptance pu
1	2	0.02	0.06	0.06
1	3	0.08	0.24	0.05
2	3	0.06	0.18	0.040
2	4	0.06	0.18	0.040
2	5	0.04	0.12	0.030
3(6)	4	0.010	0.03	0.020
4	5	0.08	0.24	0.050

TABLE III- LINE FLOWS WITHOUT TCSC AND WITH TCSC

Line No.	Line Flows without TCSC		Line Flows with TCSC	
	P (MW) pu	Q(MVAR) pu	P(MW) pu	Q(MVAR) pu
1-2	81.3	74.02	88.6	74.2
1-3	41.8	16.8	42.4	16.7
2-3	24.5	-2.5	25.4	-2.7
2-4	27.7	1.7	26.6	-1.56
2-5	54.7	5.6	54.1	5.6
3-4	19.3	4.7	21.0	2.51
4-5	6.6	0.55	7.13	0.41

TABLE IV- BUS POWERS WITHOUT TCSC AND WITH TCSC

Bus No.	Bus Power without TCSC		Bus Power with TCSC	
	P(MW) pu	Q(MVAR) pu	P(MW) pu	Q(MVAR) pu
1	131.12	90.82	131.12	90.93
2	40	-61.59	40	-61.80
3	-45	-15	-45	-15
4	-40	-5	-40	-5
5	-60	-10	-60	-10
6	131.12	90.82	131.12	90.93

V. Result and Discussion

Truncated adjustment technique is used for the device to get the convergence within 10 iterations. Table III shows the change in line flows when using the TCSC. The reactive power flow in case of TCSC is reduced for all the lines as compared to base case. There is increase in active power flow in case of TCSC. It can be seen from table IV that for TCSC the power generation by the generator at bus 1 is same as the base case. A comparison of numerical values of active and reactive bus power reveals that they are nearly equal to the system without TCSC which suggest that the system voltage almost 1p.u for the buses.

VI. Conclusion

The steady state models of TCSC are evaluated in Newton Raphson algorithm and the results obtained showed the possible power flow control range with TCSC.

VII. References

1. M. A Abdel Moamen and Narayana Prasad Padhy "Newton- Raphson UPFC Model for Power Flow Solution of Practical power network with Sparse Technique IEEE Intemational Conference on Electric Utility Deregulation, Restructuring and Power Technologies (DRPT2004) April 2004 Hong Kong 1988, pp. 3-4.
2. E. Acha. V.G.Agelidis, O.Anaya-Lara, T.J.E.Miller .Power Electric Control in Electrical system Newnes Power Engineering Series. Newnes New Delhi.
3. C.R. Fuerte-Esquivel, E. Acha "Unified power flow controller: a critical comparison, of Newton-Raphson UPFC algorithms in power flow studies "IEE Proceedings Generation Transmission. Distribution. Vol. 144, No. 5, September 1997 pg 437-443.
4. C.R. Fuerte-Esquivel, and, E. Acha 'Incorporation of UPFC model in an optimal power flow using Newtons method', IEE Proceeding Generation Transmission .Distribution. Vol 145, No.3 May1998,, pp336-344,
5. C.R. Fuerte-Esquivel E. Acha, H. Ambriz-Pérez, 'A comprehensive Newton-Raphson UPFC model for

- the quadratic power flow solution of practical power networks', IEEE Trans. on Power Systems, Vol. 15, No. 1, Feb. 2000, pp. 102-109.
6. C.R. Fuerte-Esquivel and E.Acha "Newton-Raphson algorithm for the reliable solution of large power networks with embedded FACTS devices IEE Proceedings Generation, Transmission, Distribution. Vol. 143, No. 5, September 1996 pp 447-454
 7. Hingorani N. G, 'High Power Electronics and Flexible AC Transmission System', IEEE Power Engineering Review, July 1988, pp. 3-4.
 8. N. G. Hingorani 'Flexible ac transmission', IEEE Spectrum, Apr.1993, pp. 40-45.
 9. N.G Hingorani, L. Gyugyi, 'Understanding FACTS. Concepts and Technology of Flexible AC Transmission Systems', IEEE Press, NewYork, 2000.
 10. T.Venegas, C.R. Fuerte-Esquivel 'Steady-state Modeling of Thyristor controlled series compensator for Phase Domain Load flow analysis of electric analysis. International conference on Power system Technology 1998, POWERCON '98. 344-348 vol.1.
 11. X e Da, Niu Hui, Chen Chen, "An Algorithm to Control the Power Flow in Large Systems Based on TCSC", In proceedings of International Conference on Power System Engineering, Powercon 98, Vol.1, pp. 344-348, Aug. 1998.
 12. M.Noroozian, G. Anderson" Power flow control by use of controllable series components" IEEE Transactions on Power Delivery, Vol 8, No 3 July 1993.