

PEDAL POWERED CENTRIFUGAL PUMP PURIFIED WATER SUPPLY DEVICE

Ademola Samuel Akinwonmi*, Stephen Kwasi Adzimah, Fredrick Oppong,

Department of Mechanical Engineering

University of Mines and Technology, Tarkwa, Ghana.

* E-mail of corresponding author: ademost2003@yahoo.co.uk

Abstract

This paper analyzes the design of a pedal powered purified water supply device to be used by local dwellers. It works on the principle of compression and sudden release of a tube by creating negative pressure in the tube and this vacuum created draws water from the sump into the pump while rollers push the water through to the filter where adsorption takes place to purify the water. The design composed a peristaltic pump powered by paddling, a carbon filter and hose or flexible tube. As the operator sits on the seat and paddles, the pedal crank transfer the motion to the rotor thus the rollers and the tube is squeezed by the set of rollers to move the fluid. The design analysis shows that one revolution of the pedal gives 1.1 litres of water. This design will reduce the labour, cost and weariness caused by transporting and sanitizing drinkable water for use in the homes of Ghanaian villages.

Keywords: Design, Pedal crank, Peristaltic pump, Sump, Local dwellers, Drinkable water

1. Introduction

Failure to provide safe drinking-water and adequate sanitation services to all people is perhaps the greatest development failure of the 21st century. The most egregious consequence of this failure is the high rate of mortality among young children from preventable water-related-diseases. Water is essential to sustain life, and a satisfactory (adequate, safe and accessible) supply must be available to all. Improving access to safe drinking-water can result in tangible benefit to health. Nearly, one billion people suffer needlessly without access to safe drinking water and over five thousand children die each day because of water related diseases. Water-related diseases: caused by insect vectors, especially mosquitoes, that breeds in water; include dengue, filariasis, malaria, onchocerciasis, trypanosomiasis and yellow fever. (Peter H.G., 2002). Drinkable water sources are distant from most villages in Ghana. Women and children especially spends hours of labour just to meet the basic needs of their families walking five miles and more to nearby towns just to have access to drinkable (purified) water while most children also go to school with gallons and jerry cans as shown in Fig. 1. so as to fetch water for their families after school. Some well to do inhabitants in these villages travel long distances with motor bikes and trucks which consume fuel and pollute the air.



Fig 1 Difficulties Some Communities encounter to have Access to Purified Water.

Moreover, a family of five needs a minimum of fifteen gallons of water each day. The only way to sanitize the stream water available to these villages is by boiling which also consumes precious resources and contributes to deforestation since the only source of energy for boiling this much water is firewood and charcoal. The process of selecting the water source should take account of the particular needs of low-income people, because they are at greatest risk of infectious diseases from inadequate water supply (Payment and Hunter, 2001; Howard, 2002). Groundwater constitutes 97% of global freshwater and is an important source of drinking-water in many regions of the world (Howard, 2006). However, a number of studies from low-income countries have indicated that improved access to water – and the resulting increases in the quantity of water or time used for hygiene – are the determining factors of health benefits, rather than improvements in water quality (Curtis and Cairncross, 2003).

The objective of this work is therefore to design a mechanism to be used with water filter to supply purified water for villages by harnessing the human pedal power and the nearby streams in these villages in order to reduce the labour, cost and weariness caused by transporting and sanitizing drinkable water for use in the homes of Ghanaian villages.

2. Materials and Methods.

This type of pump is selected for this work is peristaltic pump. A peristaltic pump is a type of positive displacement pump used for pumping a variety of fluids. The fluid is contained within a flexible tube fitted inside a circular pump casing (though linear peristaltic pumps have been made). A rotor with a number of "rollers", "shoes" or "wipers" attached to the external circumference. As the rollers compress the hose and move away from the inlet a vacuum is created drawing in liquid. The rollers work together to capture liquid between the pinched areas of the tube and move the liquid toward the discharge. The front roller leaves the hose, opening the captured area while the back roller pushes the liquid out the discharge. This process is called peristalsis and is used in many biological systems such as the gastrointestinal tract. This type of pump is selected for this work because of the following characteristics: because of its wider range of operating speeds, thus efficient at both high and low revolution per minutes (rpm), dry running/ self-priming/ seal less, creation of high vacuum for suction lift application, smooth passage through the pump thus no checks or obstructions, relatively high discharge pressure

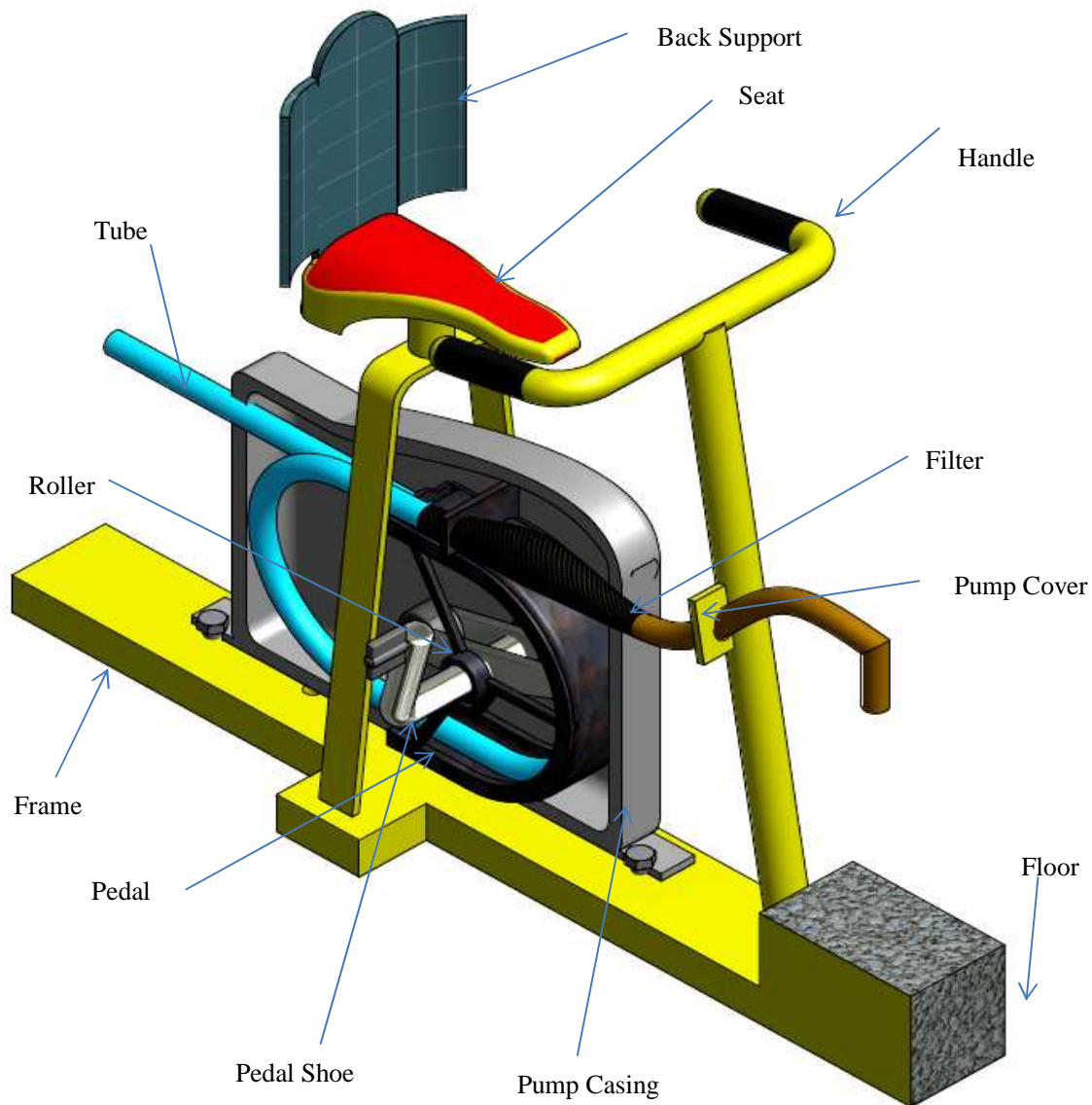

Fig. 2 Pictorial View of the Proposed Design

2.1 Principles of Operation of the Device.

This design is composed of a peristaltic pump powered by paddling, a carbon filter and hose or flexible tube as shown in Fig. 2, the person sits on the seat and paddles, the pedal crank transfer the motion to the rotor thus the rollers. The tube is squeezed by the set of rollers to move the fluid. By constricting the tube and increasing the low-pressure volume, a vacuum is created to pull the liquid into the tube. Once in the pump, the liquid is pushed through the tube by compressing the tube at a number of points in contact with the rollers. The media is moved through the tube with each rotating or oscillating motion. The water is then forced through an activated carbon filter which removes chemicals, bad taste and smell, pollutants, turbidity and other micro-organisms making the water now safe and drinkable.

2.2 Materials Selection

Components of the Proposed Design

Peristaltic Pump

Peristaltic pumps in the design as shown in Fig. 3 consist of a tube which is squeezed by a set of rollers or shoes to move fluid. By constricting the tube and increasing the low-pressure volume, a vacuum is created to pull the liquid into the tube.



Fig. 3 Peristaltic Pump with Pedals.

Since the design is intended to suit the deprived communities in the third world countries, the materials selected for this design also was selected to suit the environmental changes in different communities. Some of the problems most likely to cause damage to the design are rusting and corrosion. Based on this background knowledge, ASTM A653 Mild (low-carbon) Hot Dipped Galvanized Steel is selected for this project. This material is used for the pump casing, pedals, pump cover and other relevant parts exposed to the environment.

Galvanized steel is simply hot rolled steel to which a zinc coating has been applied for protection against corrosion.

2.3 Design Analysis and Calculations

The system design began by assessing all of the physical variables of the peristaltic pump configuration, namely case diameter (D), tubing diameter (d), tubing length (L), friction due to pedal, friction at the axle, friction where the rollers connect to the arms, and rolling friction between the roller and tubing. Dependent variables were then considered, which include flow rate (Q), rotational speed (N) and power (P). Some of the physical variables were eliminated from the possible design space (thus set at a fixed value) because they were deemed insignificant or too hard to change. These include tubing length (limited by pump design and requirements), friction coefficients, and roller diameter. Rolling friction and friction in the pedals were estimated to be negligible and were not considered in the design.

To establish an analytical model using these parameters, it is necessary to consider the relation among the various parameters. (Garneau C., 2008)

$$P_{\text{supplied}} = P(R,N)$$

$$P_{\text{required}} = P_{\text{friction}} + P_{\text{system}} = P(L,D,d,N)$$

$$Q = Q(D,d,N)$$

2.4 Theoretical Flow Rate Calculations

The theoretical flow rate is calculated as follows;

$$V = \pi^2 \left(\frac{d}{2}\right)^2 D \quad (1)$$

For a hose of 20 mm diameter and a casing diameter of 300 mm the volume displaced by the pump becomes;

$$V = \pi^2 \left(\frac{0.02}{2}\right)^2 \times 0.3 = 0.0003 \text{ m}^3$$

But the discharge per occlusion Q is given by:

$$Q = V \times N \quad Q = \frac{2V\pi N}{60} \quad (2)$$

where, N = rotor speed. The average paddle speed for human is 30-40 rpm

Therefore, considering a rotor speed of 35 rp

$$Q = 0.0011 \text{ m}^3/\text{s}$$

2.5 Frictional Head Loss

For a variety of D and d and a set ν (kinematic viscosity): N, Q, v (average fluid velocity), Re (Reynold's number), f (friction factor), H_L (head loss). Variables v , Re, f , H_L , and WHP may be found as follows:

Let the diameter of both the suction and delivery tube be equal. For the purpose of this design, the tube is considered to be smooth.

Therefore, velocity of flow in the tube;

$$v = \frac{\text{Discharge}}{\text{Area}}$$

$$v = \frac{0.0011}{\pi \left(\frac{0.02}{2}\right)^2} \quad v = 3.5 \text{ m/s}$$

In order to determine whether the flow is turbulent or laminar, it is first necessary to calculate the Reynold's number

$$\text{Renolds Number}(Re) = \frac{vD}{\nu} \quad (3)$$

Therefore, $Re = 929203.54$

Therefore the Reynolds Number $(Re) = 929203$

Since the Reynolds Number $Re > 2000$, the flow is turbulent

For smooth tubes, when $50000 \leq Re \leq 40,000,000$ the Nikuradse Experimental Equation is used to determine the coefficient of friction (f). (Rajput R.K., 2000)

The Nikuradse's experimental equation is given by:

$$\text{coefficient of friction (f)} = 0.0008 + \frac{0.05525}{Re^{0.237}} \quad (4)$$

Substituting the value of the Reynolds Number (Re)

$$\text{coefficient of friction (f)} = 0.0008 + \frac{0.05525}{(929203)^{0.237}}, f = 0.003$$

Hence, the coefficient of friction (f) is 0.003 and this value is used to determine the head losses to friction in the suction and delivery tube.

Therefore head loss to friction (H_L)

$$H_L = \frac{fLV^2}{2gd} \quad (5)$$

Therefore, for a suction length of 2 m and delivery length of 3 m;

$$H_L = \frac{0.003 \times 5 \times 3.5^2}{2 \times 9.81 \times 0.02} \quad H_L = 0.468 \text{ m}$$

2.6 Required Power

The power required to drive the pump depends on the frictional forces and torque on the arm as shown in Fig. 4.

Therefore power required is given by:

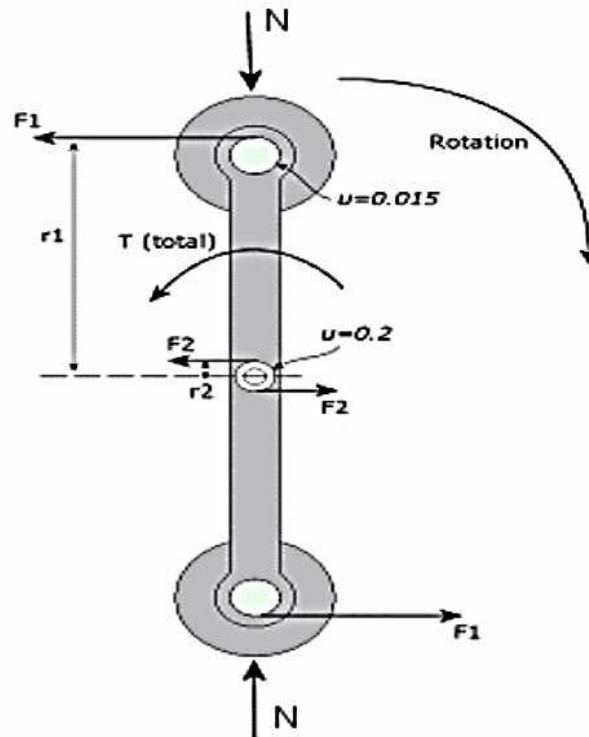

Fig. 4 Friction Forces and Torque on the Arm

In general torque is defined as force multiply by corresponding radius.

$$T = F \times r \quad (6)$$

where, T = torque

F = force pushing the rollers forward

r = moment arm of the force

where the force F is given by: $F = \mu N$

And so in this case the total torque is given by:

$$T_{\text{total}} = T_1 + T_2 = 2F_1r_1 + F_1r_1 = 2\mu Nr_1 + \mu Nr_2$$

Therefore considering one roller is in contact with the tube;

$$T_{\text{total}} = T_1 + T_2 = F_1r_1 + F_1r_1 = \mu Nr_1 + \mu Nr_2$$

where, μ = friction coefficient

The force needed by the flexible tube choosing thus Tygon™XL-60 to retract after compression is 150 N therefore that is the force that will act on the rollers, $N = 150$ N. Also assuming a friction coefficient of 0.3; r_1 casing radius minus tube diameter while r_2 is the pedal crank radius as shown in Fig. 4.

$r_1 = 130$ mm and $r_2 = 0.05$ mm

Therefore:
$$T_{total} = \{(2 \times 0.3 \times 150 \times 0.13) + (0.3 \times 150 \times 0.05)\}$$

$$T = 13.95 \text{ Nm}$$

But
$$\text{Power (P)} = T\omega \quad (7)$$

$$P = 51.13 \text{ W}$$

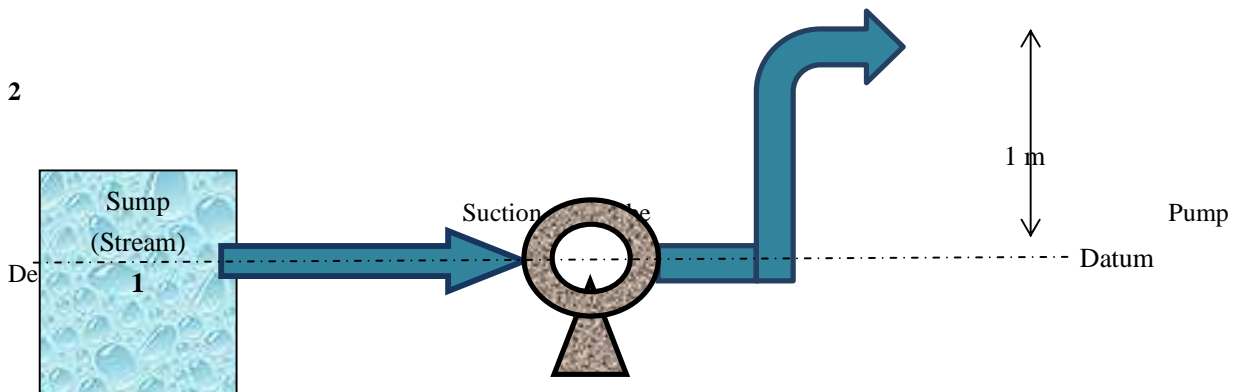

Fig. 5 System Installation

Applying Bernoulli's equation to Fig. 5 at the surface of the sump thus point 1 and the end of delivery at point 2 with point 1 as datum;

$$\frac{P_1}{\rho g} + \frac{v_1^2}{2g} + z_1 + H_p = \frac{P_2}{\rho g} + \frac{v_2^2}{2g} + z_2 + \sum \text{Losses} \quad (8)$$

For the purpose of this design, the losses include loss due to bend, frictional losses in both suction and delivery tube

and entry losses.

$$\sum \text{Losses} = \text{Friction losses } (h_{fs} + h_{fd}) + \text{Bend losses } (h_b) + \text{Entry losses } (h_e).$$

$$\text{Therefore, } H_L = h_{fs} + h_{fd} = 0.468 \text{ m}$$

For purpose of this design, a net will be installed on the tube at the beginning of suction to prevent particles that may cause blockage in the tube.

$$\text{Therefore the entrance loss is given by } h_e = \frac{K_e V^2}{2g} \quad (9)$$

where, K_e = entrance loss factor and is equal to 0.5

$$h_e = \frac{0.5 \times 3.5^2}{2 \times 9.81} = 0.312 \text{ m}$$

Again, there is two 45° tube bend in the system therefore there will be loss due to bend. For 45° bend;

$$h_b = \frac{K_b V^2}{2g} \quad (10)$$

where, K_b = bending loss factor = 1.5 for 45° bend (Rajput R.K., 2000)

$$\text{Therefore for } 45^\circ \text{ bend, } = \frac{1.5 \times 3.5^2}{2 \times 9.81} = 0.936 \text{ m}$$

$$\text{For two } 45^\circ \text{ bend, } h_b = 2 \times 0.936 = 1.87 \text{ m}$$

$$\sum \text{Losses} = 0.468 + 1.87 + 0.312 = 2.65 \text{ m}$$

From the diagram, there will be no velocity head at point 1 and therefore $v_1 = 0$. Also both point 1 and 2 are exposed

to the atmosphere therefore the pressure head at both points $\frac{P_1}{\rho g} = \frac{P_2}{\rho g} = 0$ and the datum is in line with point 1,

$$Z_1 = 0.$$

Therefore from equation

$$\frac{P_1}{\rho g} + \frac{v_1^2}{2g} + z_1 + H_p = \frac{P_2}{\rho g} + \frac{v_2^2}{2g} + z_2 + \sum \text{Losses}$$

$$H_p = 4.274 \text{ m}$$

The power needed to overcome all losses in the tube and to push the fluid is calculated as:

$$\text{Power delivered by the pump} = \rho g Q H_p \quad (11)$$

$$= 46.12 \text{ W}$$

$$\text{efficiency}(\eta) = \frac{\text{power delivered by the pump}}{\text{power required by the pump}}$$

$$= 0.90$$

3. Results and Discussion

The design was focused on all the processes of conception, invention, visualisation, calculation, refinement and specification of details that determine the form of the product. The design has gone under force analysis so that its performance criterion will not fail in any sense. The main physical parameters of the design are determined through the appropriate calculations and practical considerations with reasonable assumptions. It is discovered that the design is simple, cheap, efficient and affordable as could be seen from the readily available materials used. Figures 1 shows the already existing way of getting access to water while figures 2 and 3 show the design and one of its components. It can be seen from the design analysis that the rate of discharge per occlusion is $0.0011 \text{ m}^3/\text{s}$ is considered reasonable. The power required to drive the pump is 51.13 W and the efficiency gives 90 % which are all good and reliable.

4. Conclusion

The benefits associated with access to safe drinking-water provide a strong argument to increase resource allocations to interventions aimed at further improving the current drinking-water situation, as a key entry point for achieving much wider livelihood benefits.

The pedal powered purified water supply system is a new invention that utilizes simple inventions and puts them all together to help villages in developing countries like Ghana to have daily access to safe drinking water all by harnessing the energy of pedal power.

Acknowledgement

The authors are thankful to Prof. Adetunde, I.A, the Dean, Faculty of Engineering, University of Mines and Technology, Tarkwa, Ghana for his valuable comments and suggestions.

References

- Curtis, V. And Cairncross, S. "Effect of Washing Hands with Soap on Diarrhoea Risk in the Community: A Systematic Review". *Lancet Infectious Diseases* 3, (2003).pp. 275–281.
- Garneau, C. McNamara, K. and Chung, J. "Peristaltic Pump Project", Unpublished Final Project Report, Team D, ME 340.4, (2008), 41pp.
- Howard, G. "Groundwater and Public Health", In: Schmoll O. et al. (eds). *Protecting Groundwater for Health: Managing the Quality of Drinking-Water Sources*, London, International Water Association Publishing, (2006), pp. 3–19.
- Payment, P., Hunter, P. R. "Endemic and Epidemic Infectious Intestinal Disease and Its Relationship to Drinking Water", In: Fewtrell L., Bartram J. (eds), *Water Quality Guidelines, Standards and Health*, London, International Water Association (IWA) Publishing, (2001), 61–88pp.
- Rajput, R. K. "Fluid Mechanics And Hydraulic Machines", S. Chand & Company Ltd, Ram Nagar, New Delhi-110 055, (2000), 1361 pp.