

Innovative Systems Design and Engineering
ISSN 2222-1727 (Paper) ISSN 2222-2871 (Online)
Vol 3, No 3, 2012

www.iiste.org

Simulation of Unified Power Quality Conditioner for Power Quality Improvement Using Fuzzy Logic and Neural Networks

L.Dinesh^{*}, S.Srinivasa Rao, N. Siva Mallikarjuna Rao

Department of Electrical and Electronics Engineering, Gitam University, Visakhapatnam 530045, Andhra Pradesh, India

*dinesh_245@yahoo.com

Abstract

One of the major concerns in electricity industry today is power quality. It becomes especially important with the introduction of advanced and complicated devices, whose performance is very sensitive to the quality of power supply. The electronic devices are very sensitive to disturbances and thus industrial loads become less tolerant to power quality problems such as voltage dips, voltage sags, voltage flickers, harmonics and load unbalance etc. At present, a wide range of very flexible controllers, which capitalize on newly available power electronics components, are emerging for custom power applications. Among these, the distribution static compensator, dynamic voltage restorer and unified power quality conditioner which is based on the VSC principle are used for power quality improvement. In this project, a fuzzy logic controller with reference signal generation method is designed for UPQC and compared its performance with artificial neural network based controller. This is used to compensate current and voltage quality problems of sensitive loads. The results are analyzed and presented using matlab/simulink software .

Keywords: power quality, upqc, voltage sag, fuzzy logic controller, neural networks

1. Introduction

Power quality is the set of limits of electrical properties that allows electrical system to function in proper manner without significant loss of performance Like flexible ac transmission system, the term custom power use for distribution system. Just as facts improve the reliability and quality of power transmission system, the custom power enhances the quality and reliability of power that is delivered to customers. The main causes of a poor power quality are harmonic currents, poor power factor, supply voltage variations, etc. In recent years the demand for the quality of electric power has been increased rapidly. Power quality problems have received a great attention nowadays because of their impacts on both utilities and customers. Voltage sag, swell, momentary interruption, under voltages, over voltages, noise and harmonics are the most common power quality disturbances. There are many custom power devices. The devices either connected in shunt or in series or a combination of both. The devices include D-STATCOM, DVR and UPQC etc. One of the most common power quality problems today is voltage dips. A voltage dip is a short time event during which a reduction in R.M.S voltage magnitude occurs. Despite a short duration, a small deviation from the nominal voltage can result in serious disturbances. A voltage dip is caused by a fault in the utility system, a fault within the customer's facility or a large increase of the load current, like starting a motor or transformer energizing. Unified power quality conditioner (UPQC) is one of the best custom power device used to compensate both source and load side problems. It consists of shunt and series converters connected back to back to a common dc link. It can perform the functions of both DSTATCOM and DVR. In this paper a fuzzy logic controller is used to compensate voltage sag and it is compared with neural network based controller.

2. Upqc System with Control Methods

UPQC mainly includes three parts: the series active power filters, shunt active power filters and energy storage capacitors. The series and shunt active power filter couples together through the DC-link energy storage capacitors. Series APF connected to the grid and load by coupling transformer is mainly used to adjust the load voltage amplitude and compensate the power supply voltage sag in the controlled voltage source mode. Shunt active filter connected to the load is used to compensate load currents.

2.1 Voltage Sag Energy

The voltage sag energy is defined as

$$E_{vs} = \int_0^T \left[1 - \frac{V(t)}{V_{nom}} \right]^2 dt \quad (2.1)$$

Where V is the magnitude of the voltage and V_{nom} is the nominal voltage and T is duration of the sag.

3. Fuzzy Logic Controllers

The logic of a approximate reasoning continues to grow in importance, as it provides an in expensive solution for controlling know complex systems. Fuzzy logic controllers are already used in appliances washing machine, refrigerator, vaccum cleaner etc. Computer subsystems (disk drive controller, power management) consumer electronics (video, camera, battery charger) C.D.Player etc. and so on In last decade, fuzzy controllers have convert adequate attention in motion control systems.

3.1 Implication methods

The implication step (3) was introduced for the evaluation of individual rules.

Methods:

- a) MAMDANI
- b) SUGENO

4. Artificial Neural Networks

Artificial Neural Networks are relatively electronic models based on the neural structure of the brain The brain basically learns from experiences. It is natural proof that are beyond the scope of current computers are indeed solvable by small energy efficient packages. This brain modeling also promises a less technical way to develop machine solutions. The ANN is made up of interconnecting artificial neurons. It is essentially a cluster of suitably interconnected nonlinear elements of very simple form that possess the ability to learn. A one-layer network with R input elements and S neurons follow. In this network, each element of the input vector p is connected to each neuron input through the weight matrix W . The i th neuron has a summer that gathers its weighted inputs and bias to form its own scalar output $n(i)$. The various $n(i)$ taken together form an S -element net input vector n .

4.1 Training an artificial neural network

Once a network has been structured for a particular application, that network is ready to be trained. To start this process the initial weights are chosen randomly. Then, the training, or learning, begins. There are two approaches to training – ‘SUPERVISED’ and ‘UNSUPERVISED’. Supervised training involves a mechanism of providing the network with the desired output either by manually “grading” the network’s performance or by providing the desired outputs with the inputs. Unsupervised training is where the network has to make sense of the inputs without outside help. The vast bulk of networks utilize supervised training. Unsupervised training is used to perform Some initial Characterization on inputs. Training can also be classified on basis of how the training pairs are presented to the network. They are ‘INCREMENTAL TRAINING’ and ‘BATCH TRAINING’. In incremental training the weights and biases of the network are updated each time an input is presented to the network. In batch training the weights and biases are only updated after all of the inputs have been presented.

5. Design of Upqc Using Matlab Simulation

To verify the operating performance of the proposed UPQC, a 3-phase electrical system, a fuzzy logic controller with reference signal generation method is designed for UPQC and compared its performance

with Artificial neural network based controller is simulated using MATLAB software.

5.1 Fuzzy logic and neural network controllers design

The aim of the control scheme is to maintain constant voltage magnitude at a point where a fault is connected. The controller input is an error signal obtained from the reference voltage and the value rms of the terminal voltage is measured. Such error is processed by a fuzzy logic and neural network based controllers where the output is the angle δ , which is provided to the PWM signal.

5.2 Voltage control

The sinusoidal signal $V_{control}$ (REFERENCE VOLTAGE) is phase-modulated by means of the angle δ i.e,

$$\begin{aligned} V_A &= \sin(\omega t + \delta) \\ V_B &= \sin(\omega t + \delta - 2\pi/3) \\ V_C &= \sin(\omega t + \delta + 2\pi/3) \end{aligned} \quad (5.1)$$

The $V_{control}$ is compared against a triangular signal in order to generate the switching signal for the VSC valves.

$$M_a = \frac{V_{control}}{V_{tri}} = 1 \text{ p.u} \quad (5.2)$$

6. Neural Network Training Algorithm

NEWFF (PR, [S1 S2 ... SN1], {TF1 TF2 ... TFN1}, BTF, BLF, PF) takes,

PR – Rx2 matrix of min and max values for input elements

Si – Size of i^{th} layer, for N1 layers

TFi – Transfer function of i^{th} layer, default = 'tansig'

BTF – Back prop network training function, default = 'trainlm'

BLF – Back prop weight/bias learning function, default = 'learnqdm'

net = init (net);

Before training a feed forward network, the weights and biases must be initialized. The initial weights and biases are created with the command `init`. This function takes network object as input and returns a network object with all weights and biases initialized. Here is all weights and biases initialized

6.1 Training the input

There are two types of training procedures according to the way in which the inputs are applied to the network. They are 'incremental training' where each training pair will be applied one after the other and 'batch training' in which entire set of training pairs will be applied at once. The syntaxes for them are as below

net = train (net, p, t);

6.3 Simulation

The function `sim` simulates a network. `sim` takes the network `p`, and the Network objects `net`, and returns the network outputs 'k'.

K = sim (net, p);

6.4 Reference Signal Generation

Reference voltage generation which is used for series converter control and Reference current generation used for shunt converter control are generated using Parks transformation. The source current is given as:

$$i_s = i_a * e^{j(\theta)} + i_b * e^{j(\theta - 120)} + i_c * e^{j(\theta + 120)}$$

$$= i_a(\cos(\theta) + j \sin(\theta)) + i_b(\cos(\theta - 120) + j \sin(\theta - 120)) + i_c(\cos(\theta + 120) + j \sin(\theta + 120)) \quad (6.1)$$

$$I_d = i_a \cos(\theta) + i_b \cos(\theta - 120) + i_c \cos(\theta + 120) \quad (6.2)$$

$$I_q = i_a \sin(\theta) + i_b \sin(\theta - 120) + i_c \sin(\theta + 120) \quad (6.3)$$

7. Conclusion

This thesis work is mainly devoted to the study of Power Quality problems and its compensation with **Unified power quality conditioner (UPQC)**. Results obtained from this study provide useful information regarding the behaviour of different controllers used for power quality improvement connected to distribution line. The controllers mainly used for power quality improvement are Fuzzy logic controller and Artificial neural network based controller. Fuzzy logic controller with reference signal generation method is designed for Unified power quality conditioner (UPQC) and compared its performance with artificial neural network based controller. A New functionality is added to the UPQC system to quickly extract the reference signals directly for load current and supply voltage with a minimal amount of mathematical operands. The highly developed graphic facilities available in MATLAB/SIMULINK were used to conduct all aspects of model implementation and to carry out extensive simulation studies on test system. The simulation results show that the UPQC with fuzzy logic controller compensates 75% of voltage sag during fault condition. While UPQC with artificial neural network based controller compensates 95% of voltage sag. Hence as compared to the response obtained with Fuzzy controller, Neural network based controller have great advantage of flexibility.

7.1 Scope for future work

Proposed model of UPQC is to compensate source side and also load side problems using fuzzy logic and ANN controllers. The work can be extended to compensate total drop in the system using combined NEURO-FUZZY control (Adaptive neuro fuzzy controller).

References

- Vadirajacharya G. Kinhal, Promod Agarwal, and Hari Oam Gupta (2011), *Senior Member, IEEE* "Performance Investigation of Neural-Network- Based Unified Power-Quality Conditioner" *IEEE transactions on power delivery*, vol.26.
- Ahmet Teke, Lütfü Saribulut, and Mehmet Tümay (2011) "A Novel Reference Signal Generation Method for Power- Quality Improvement of Unified Power-Quality Conditioner" *IEEE transactions on power delivery*.
- A. Zouidi, F. Fnaiech, and K. AL-Haddad (2006), "Neural network controlled three-phase three-wire shunt active power filter," in *Proc. IEEE ISIE*, Montreal, QC, Canada, Jul. 9–12, pp. 5–10.
- L. H. Tey, P. L. So, and Y. C. Chu (2004), "Unified power quality conditioner for improving power quality using ANN with hysteresis control," in *Proc. Int. Conf. Power System Technology*, pp. 1441–1446.
- Ruiye Liu, Ning Xia, Xiaonan Wang" The Research on Fuzzy-PID Control in Unified Power Quality Conditioner".
- Timothy Ross J. (1995), "Fuzzy Logic with Engineering Applications", McGraw-Hillbook Company; University of Mexico.
- HUANG Min, ZHA Xiao-ming, CHEN Yun-ping (2002), The controller of fuzzy changing structure of parallel power quality conditioner[J]. *Power System Technology*, 26(7):11-14.

L .Dinesh born in the year 1989 is currently doing his Post Graduate course in Power Systems And

Automation in Electrical and Electronics Engineering, department of GITAM Institute of Technology, GITAM University, Visakhapatnam, India, the B.Tech degree in Electrical and Electronics Engineering from JNTU Kakinada, Andhra Pradesh, India, in 2010.

S. Srinivasa Rao received his master degree in Electrical Power Systems from JNTU Anantapur, in 2008, B.Tech degree in Electrical and Electronics Engineering from G.M.R Institute of Technology, India, in 2004. He is currently working as an Assistant Professor of Electrical and Electronics Engineering department at GITAM Institute of Technology, GITAM University, Visakhapatnam, Andhra Pradesh, India. His research interest includes Power Quality.

N. Siva Mallikarjuna Rao received his master degree in Control Systems from JNTU Anantapur, in 2006, B.Tech degree in Electrical and Electronics Engineering from Narasraopeta Engineering College, India, in 2003. He is currently working as an Assistant Professor of Electrical and Electronics Engineering department at GITAM Institute of Technology, GITAM University, Hyderabad, Andhra Pradesh, India. His research interest includes Control systems.

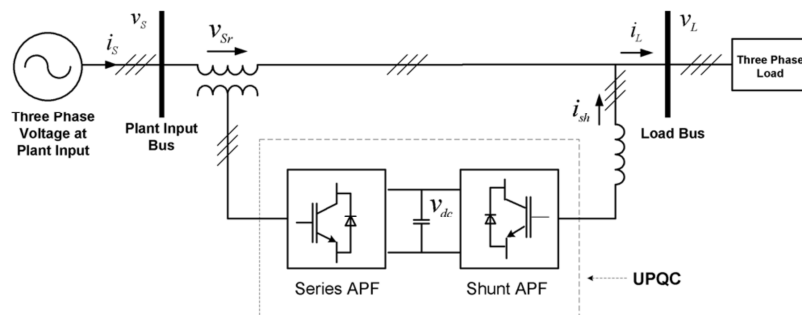

Figure 1. Topology of upqc

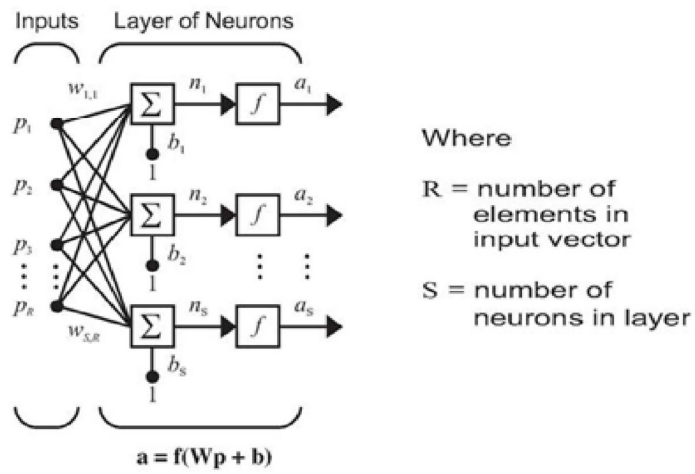

Figure 2. Single layer feed forward network

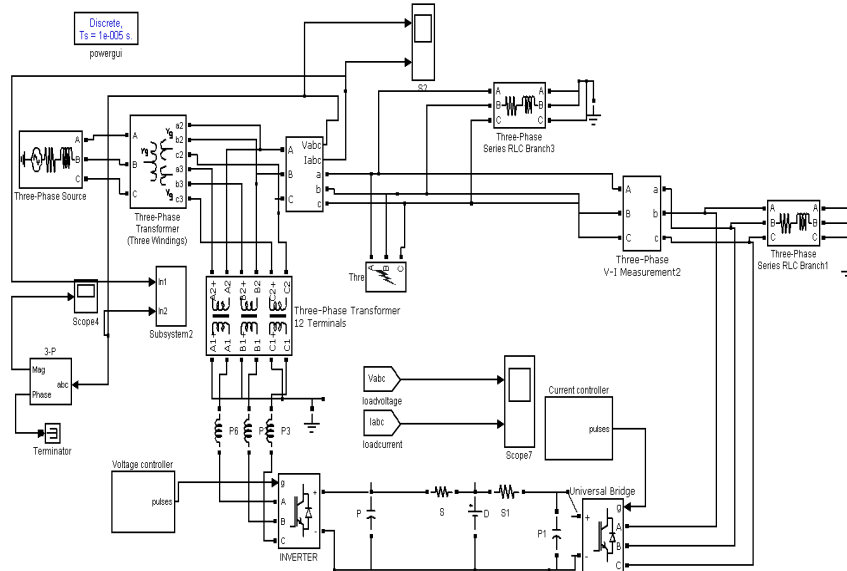

Figure 3. Matlab simulation model of upqc

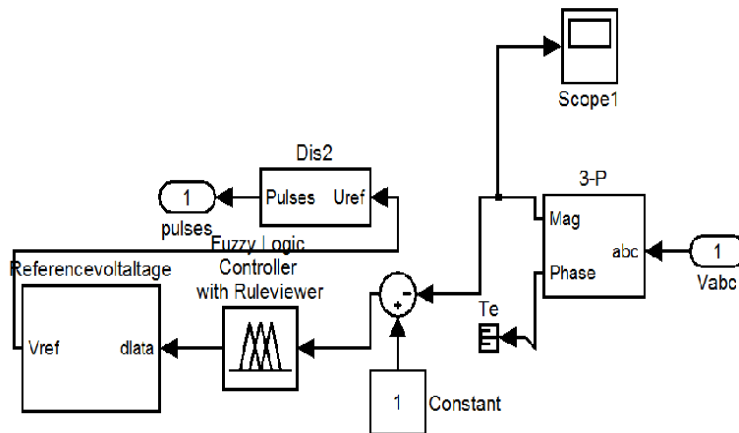

Figure 4. Voltage controller using fuzzy

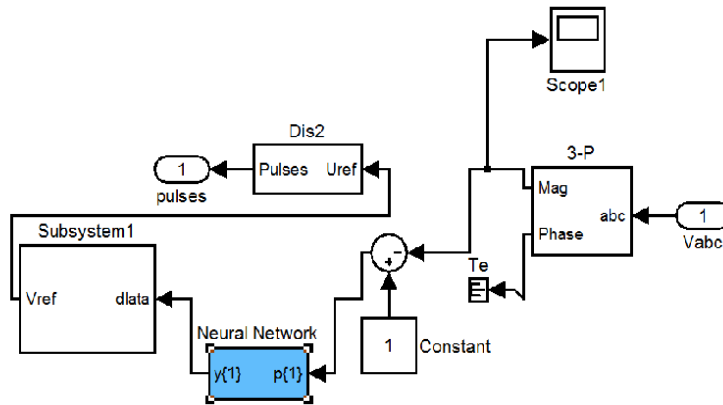

Figure 5. Voltage controller using neural networks

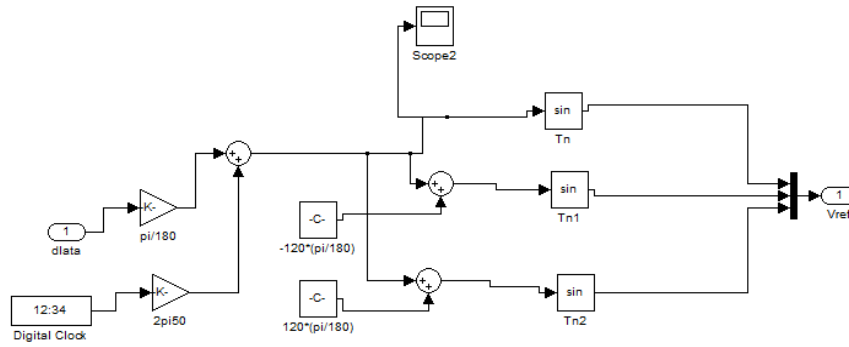

Figure 6. Modulator signal generation

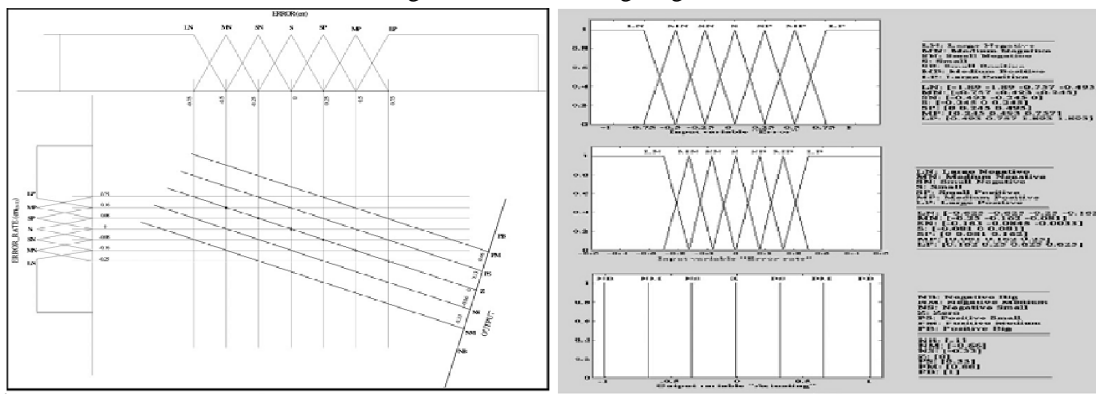

Figure 7. Membership figures for input and output

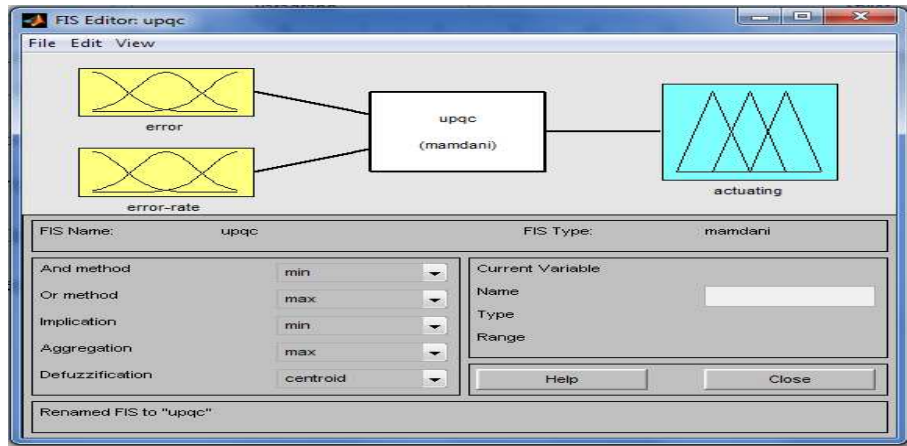

Figure 8. fuzzy interface system

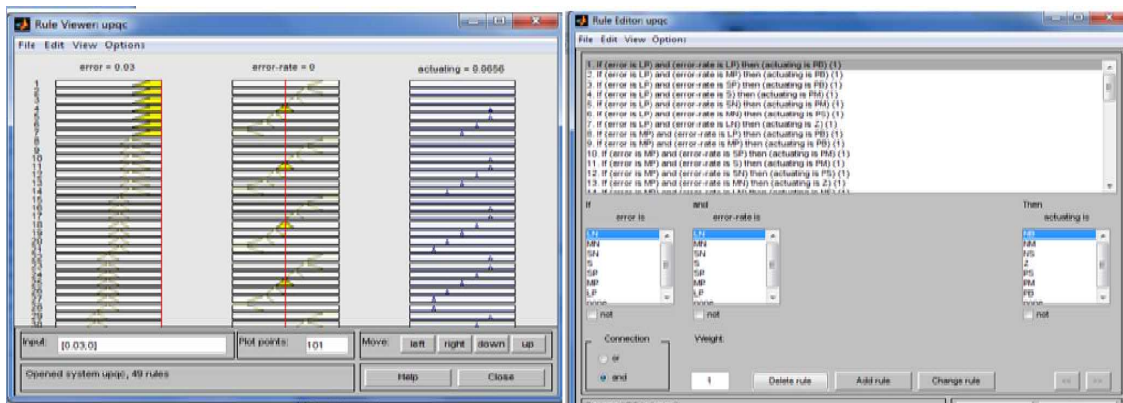

Figure 9. fuzzy Rule Viewer and Fuzzy Rule Editor

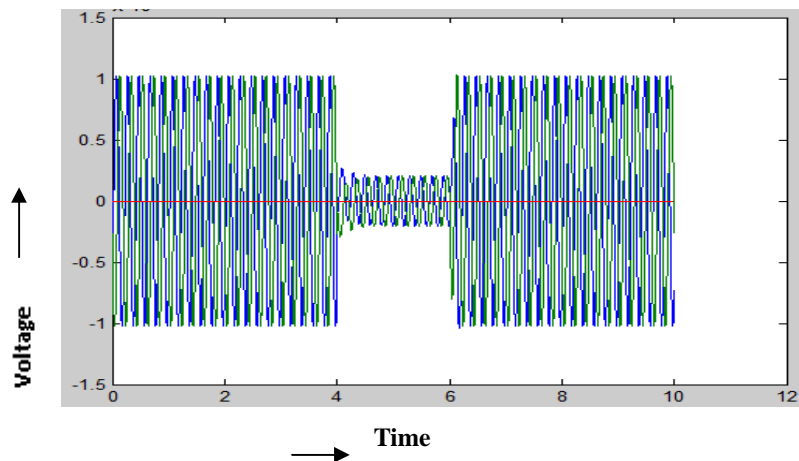

Figure 10. Source voltage due to 3 phase fault

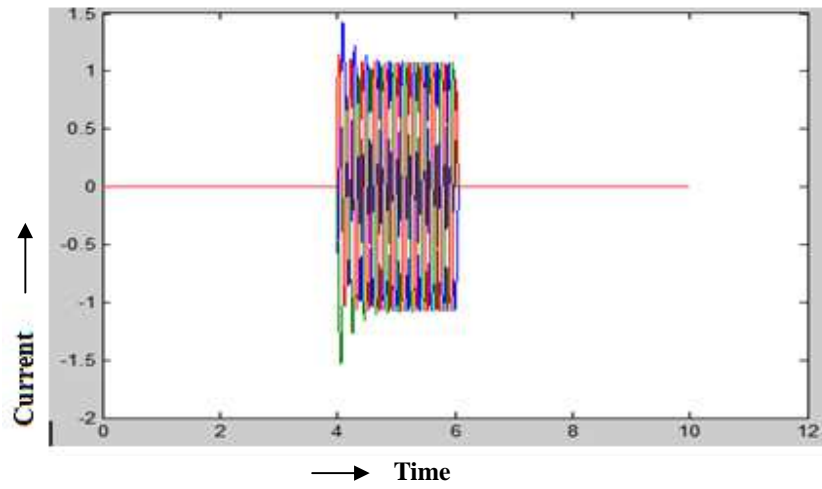

Figure 11. Load current due to 3 phase fault

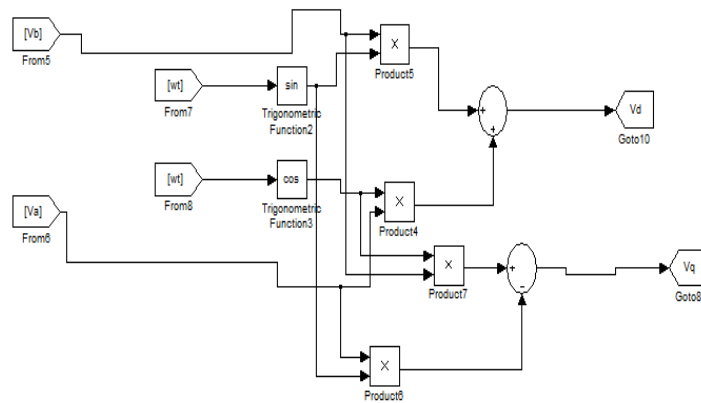

Figure 12. Matlab/Simulink Model for Reference current signal generation

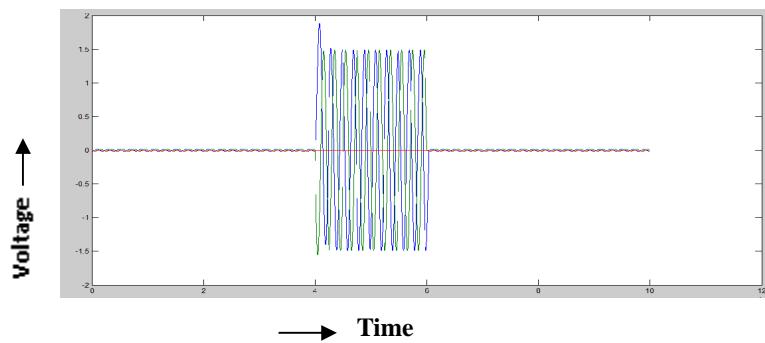

Figure 13. The injected voltage to the PCC at disturbance (V_{inj})

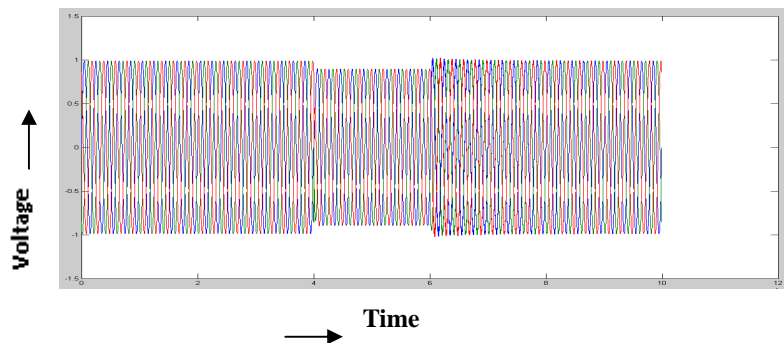

Figure 14. Load voltage with fuzzy logic controller

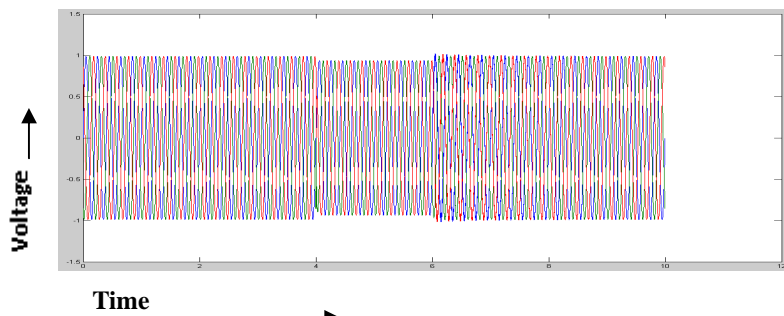

Figure 15. Load voltage with artificial neural network

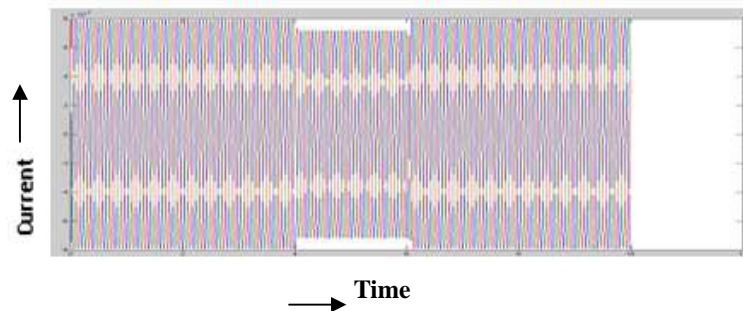

Figure 16. Load current with fuzzy logic controller

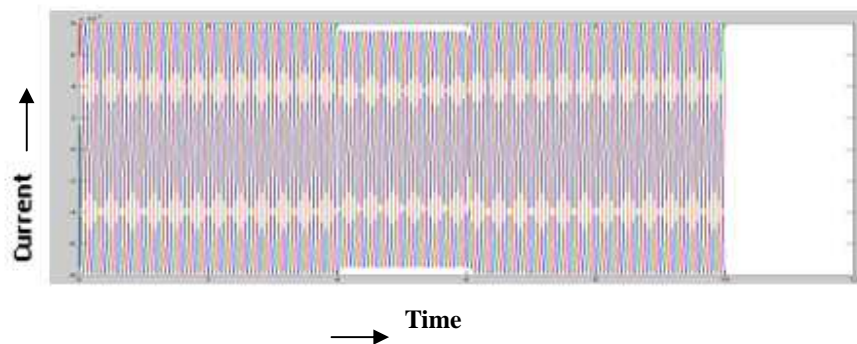

Figure 17. Load current with artificial neural network

Table 1. Circuit Parameters For UPQC

System quantity	Supply voltage(Vs) Frequency	380Vrms 50Hz
Series converter	Filter inductor(Lf) Filter capacitor(Cf)	8mH 36Uf
Shunt converter	DC link capacitor Reference voltage Smoothing inductor	1100uF 650Vdc 15mH
Non liner load (R+jwL)	40 ohm +j 10 ohm	

Table 2. Comparison Of Voltage Profile Between Fuzzy Logic And Neural Networks Controllers

Controller	Voltage Profile (V)	Energy Loss(J)
Fuzzy logic controller	0.2pu to 0.8pu and current waveform is sinusoidal	Decreased from 0.099 to $1.27 \cdot 10^{-3}$
Neural network	0.2pu to 0.95pu current waveform is sinusoidal	Decreased from 0.099 to $8.2 \cdot 10^{-5}$

From the above table it is concluded that the voltage profile is increased from 0.2 to 0.8pu using Fuzzy logic controller and 0.2 to 0.95 using neural network. Hence ANN controller provides better voltage profile which is the main requirement in the power system operation when compared with Fuzzy logic controller.

This academic article was published by The International Institute for Science, Technology and Education (IISTE). The IISTE is a pioneer in the Open Access Publishing service based in the U.S. and Europe. The aim of the institute is Accelerating Global Knowledge Sharing.

More information about the publisher can be found in the IISTE's homepage:

<http://www.iiste.org>

The IISTE is currently hosting more than 30 peer-reviewed academic journals and collaborating with academic institutions around the world. **Prospective authors of IISTE journals can find the submission instruction on the following page:**

<http://www.iiste.org/Journals/>

The IISTE editorial team promises to review and publish all the qualified submissions in a fast manner. All the journals articles are available online to the readers all over the world without financial, legal, or technical barriers other than those inseparable from gaining access to the internet itself. Printed version of the journals is also available upon request of readers and authors.

IISTE Knowledge Sharing Partners

EBSCO, Index Copernicus, Ulrich's Periodicals Directory, JournalTOCS, PKP Open Archives Harvester, Bielefeld Academic Search Engine, Elektronische Zeitschriftenbibliothek EZB, Open J-Gate, OCLC WorldCat, Universe Digital Library, NewJour, Google Scholar

