

A Scenario-Based Learning of Electrical Circuits

Alexandros Papadimitriou

School Teacher Advisor of the Greek Ministry of Education, Athens, Greece

apapadim@sch.gr

Abstract

This paper presents a framework of an educational scenario for the teaching of electrical circuits at senior high schools. This scenario aims at the development of exploratory and critical thinking of students, the development of make-decision skills and knowledge transfer skills from one framework to another, the ability of collaboration and in common approach of problem solving. During the lessons, the student teams discover the formulas and principles of the total resistance, the voltage drop across the resistances, and the flowing current through the resistances, in series, in parallel, and in combination resistance circuits by comparing the circuits with each other and guided by the exploratory questions and scaffolding as well. At the end, the student teams solve an open-ended problem based upon their knowledge obtained through the activities. This framework has adopted and applied by educators with a great success.

Keywords: Educational scenario, Problem solving, Social constructivism, Cooperative learning.

1. Introduction

The aim of this paper is to present an innovative scenario framework for the learning of electrical circuits by senior high school students or technical high school students.

Numbers of studies on the learning of electrical circuits indicate that students still have many difficulties and misunderstandings after systematic instruction (McDermott & Shaffer, 1992; Duit & von Rhöneck, 1998). Most typical difficulties are inability to relate theoretical models of electricity to real circuits, incomplete understanding of basic concepts of electricity, and incapacity to reason about the behaviour of electric circuits (McDermott & Shaffer, 1992; Duit & von Rhöneck, 1998). These difficulties and misconceptions seem to be very resistant to change (Chi, 2008). There have been several attempts to overcome the difficulties in electricity learning. Traditional electricity teaching using textual learning material, concrete application tasks or hands-on laboratory work has been quite ineffective.

After series of instruction learners have been still found to hold many misconceptions about electricity. The use of application questions and tasks has reported to be partially useful for developing understanding of electricity concepts (Wang & Andre, 1991). Research also indicates that laboratory-based hands-on activities can offer special benefits for understanding of concepts and correcting misconceptions (McDermott & Shaffer, 1992). However, some of the misconceptions are so strong and resistant that even direct experience with the real phenomena may not always be effective for changing students' opinions (Ronen & Eliahu, 2000). There have also been attempts to replace hands-on laboratory work with electricity simulations. Results of these studies provide rather inconsistent picture about the effectiveness of simulations compared to laboratory exercises. Some studies speak in favour of simulations (Ronen & Eliahu, 2000). Inquiry-based simulations may provide one solution (Hung & Chen, 2002). Students are required to resolve their cognitive conflict through visualization of physical phenomena via dynamic computer simulation and peer support in cooperative learning groups (Abdullah and Shariff, 2008).

DiSessa (2001) suggests that Physics is best taught through experiments, labs, demonstrations and visualizations which help the learners understand physical phenomena conceptually. According to Conconi *et al* (2006), Physics being an experimental science, observation, measuring and theoretical speculations are processes that cannot be separated from the physical knowledge construction, even in the classroom. According to Snowman *et al* (2008), educators should consider stimulating the basic purposes of schooling: curiosity, exploration, problem solving, and communication. Physics instructors generally believe that the problem-solving leads to the understanding of physics and that it is a reliable way to demonstrate the understanding for purposes of evaluation (Maloney, 1994). Also, physics education researchers have developed a number of strategies that have been shown to be effective in improving student problem

solving performance, such as when students work with other students, or with a computer, where they must externalize and explain their thinking while they solve a problem (Reif & Scott, 1999).

The problem-solving scenarios follow a socio-constructivist approach and promote the inductive and deductive way of learning, as students are encouraged to discover, test structures and apply the knowledge obtained to new situations. Generally, the scenarios promote and support problem-based learning, where students can be creative, learn how to combine knowledge from different thematic areas, can think critically, analytically, and learn how to solve real problems. While solving the problems, they are carefully guided to learn the associated concepts and procedures. Also, the scenarios would require students to reflect upon the whole resource by predicting, hypothesising, and experimenting to produce a solution and it also provides for coaching at critical times, and scaffolding of support, where the teacher provides the skills, strategies and links that the students are unable to complete the task (Carroll, 1999).

Scaffolding is a process in which students are given support until they can apply new skills and strategies independently and it has been found to be an excellent method of developing students' higher level thinking skills (Rosenshine & Meister, 1992). Vygotsky's (1978) theories of scaffolding knowledge through peer discussion and interaction has been applied systematically under the rubric of cooperative learning. Cooperative learning is an instructional technique in which students work together in structured small teams in order to accomplish shared goals (Johnson & Johnson, 1989). In cooperative team problem solving (Heller & Hollabaugh, 1992): (a) the students have a chance to practice the strategy until it becomes more practical; (b) complex problems can be solved easier by teams rather than individuals; (c) students get practice developing and using the language of physics; (d) in their discussion with each other, students must deal with and resolve their misconceptions; (e) at the brainstorming of the problems, students are less intimidated because they are not answering as an individual, but as a team. Additionally, the cooperative team problem solving positively affects on the attitude scores of students and on physics achievements and achievement motivation of students (Gök, 2010). Johnson & Johnson (1989), suggest that with the help of sufficient scaffolding, or dynamic team support in cooperative environments, provided by inquiry-based computer simulations, an instructor, a more skilled partner, or a more capable peer, will enable concrete operational students to enhance their reasoning skills toward formal thought.

Activities supported by the proper scaffolding can help students develop expertise across all four domains of learning, as follows (Lombardi, 2007): (a) cognitive capacity to think, solve problems, and create; (b) affective capacity to value, appreciate, and care; (c) psychomotor capacity to move, perceive, and apply physical skills; and (d) conative capacity to act, decide, and commit.

This paper aims to provide a scenario framework by using inquiry-based simulations, explorations, guided discovery and communication for helping students to better understand electricity and acquire correct scientific model about electrical circuits. Through a process of inquiry, the empirical evidence is transformed (e.g., natural phenomena) into revised and new knowledge structures (Lee, 1999). Explorations promote a new state of understanding or equilibrium or self-regulation when new concepts and principles are derived from the exploration experience where students collect and analyze data via computer simulation in cooperative learning team (Abdullah and Shariff, 2008). Creating a scenario is not a simple task. In order for it to be authentic, we must try to make the scenario as realistic as possible. Elements of a scenario include the role the students will play at each stage of scenario, the tools they will use, and the sequence of activities in which they will be engaged. For the sake of their joint activities, students need to articulate their opinions, predictions and interpretations. Conflict sometimes arises in peer collaboration when students disagree with each other in their interpretations or approaches to the task. When solving a problem, students co-construct shared knowledge and understanding by complementing and building on each other's ideas (Tao & Gunstone, 1999).

The remainder of this article is structured as follows. In the Section 2 the principles of team formation in the scenario are described. In the Section 3 the scenario framework is described, and in the Section 4 a conclusion for the present work is presented.

2. Team Formation in the Scenario

In order to have effective teams we should take into account team policies and expectations. Effective teams are characterized by mutual trust and respect, acceptance, understanding, courtesy, ability, willingness, effective

collaboration, and the low number of members who must possess specific knowledge, skills, shared beliefs and attitudes (Oakley et al., 2004; Baker et al., 2006). Research shows that students working in small teams tend to learn more of what is taught, retain it longer than when the same content is presented in other instructional formats, and appear more satisfied with their classes (Barkley et al., 2005).

Taking into account the Oakley et al. (2004) suggestion, I adopt that the teams should be formed with three (recommended) or four students who have the top, average, lower and/or lowest scores. For three person teams, the specific roles should be assigned as follows: Coordinator, Recorder, and Discusser. For four person teams, the specific roles should be assigned as follows: Coordinator, Recorder, Discusser, and Energizer. The responsibilities for each role are defined below.

- Coordinator: directs the sequence of steps (e.g., we need to move on to the next step), manages time (e.g., let us come back to this later if we have time), reinforces merits of everyone's ideas, ensures that each team member participates, keeps team focused on task, summarizes (if there is no Energizer in the team) the team's discussion and conclusions (e.g., so here is what we have decided) or how the solution was attained.
- Recorder: writes down actual steps, makes sure everyone understands both the solution and the strategy used to get it, checks for understanding of all team members (e.g., George, explain me this diagram) or for the final solution for accuracy and turns it in by the due date and time, makes sure all team members agree on each step of the problem solution or on plans and actions (e.g., are we in agreement on this?), submits reports for the team.
- Discusser: makes sure all possibilities (e.g., possible problem-solving strategies or plans and actions) are explored (e.g., what other possibilities are there?), suggests alternative approaches or concerns with suggested solutions (e.g., let us try to look at this another way), provides reasoning and explanations of steps to team members if necessary, ensures problem and data interpretation is correct (e.g., I am not sure we are on the right track).
- Energizer: energizes the team when motivation is low by suggesting a new idea (e.g., we can do this!), through humor or by being enthusiastic (e.g., that is a great idea!). Summarizes (restates) the team's discussion and conclusions (e.g., so here is what we have decided).

These roles should be better to rotate for every assignment. The student teams would be better to be formed by sociometric tests and sociograms.

Also, the following suggestions of Michaelsen et al. (1997) for the design of effective team activities should be taken into consideration in team formation:

- team activities and assignments can be a highly effective tool for developing both students' mastery of basic conceptual material and their higher-level thinking and problem solving skills.
- the vast majority of student or workshop participants dysfunctional behaviours (e.g., social loafing, one or two members dominating the discussion, etc.) and complaints (e.g., having to carry the dead wood, the instructor is not teaching, etc.) are the result of bad assignments not bad learners.
- the key to designing effective team assignments is to maximize the extent to which the learning tasks promote the development of cohesive learning teams, and
- the single best way to gauge the effectiveness of team assignments is the observe the level of energy that is present when the results of the small team discussions are reported to the class as a whole.

3. Scenario Framework

The proposed scenario framework consists of five activities. In each activity, the students study different section of electric circuits. This scenario may be taught in interdisciplinary instruction by the engagement of Mathematicians, Physicians, and Electrical or Electronic Engineers. Team-teaching may be the most obvious way of getting interdisciplinary instruction into the classroom. Student learning outcomes expressed at all six levels of Bloom's taxonomy become the foundation for the selection and design of assignments, teaching strategies, and instructional materials such as simulations based on the CircuitMaker software. The six levels of Bloom's taxonomy reflect not only the importance of acquiring information but also the intellectual processes of application, analysis, evaluation, and

creation by which we transform raw data into formalized knowledge structures. Utilizing the taxonomy during the instructional planning stage, we can establish the ability to construct knowledge as a meaningful student learning outcome and embed its practice explicitly into the essential components of their courses (e.g., classroom instruction, evaluation). Bloom's taxonomy has proven itself a flexible and enduring structure to help define the parameters of the constructivist classroom, lend rigor to the teaching of critical thinking skills, and guide purposeful learning in contemporary postsecondary teaching environments (Lee, 1999).

Also, within an epistemological framework, the tenets of constructivism as pertaining to instructional practice may be summed up as follows. Firstly, understanding is a creative process resulting from the construction of knowledge in the mind of the individual. Secondly, therefore, real learning requires deep cognitive engagement by the learner in purposeful and effortful activities. Finally, the learner needs to incorporate new knowledge correctly by recognizing symmetries, similarities and differences between a range of ideas, concepts, observations and experiences. Neither the creative powers nor the prior knowledge of the learner may be ignored. The learner needs to relate new knowledge both to previously learned knowledge and to experiential phenomena so that he or she can build a consistent picture of the physical world (Buffler and Allie, 1993).

As I mentioned above, the proposed scenario uses inquiry-based simulations, explorations, guided discovery, and communication. Students actively construct knowledge by designing experiments, making observations, proposing hypotheses, solving problems, answering questions, gathering and analyzing data, synthesizing, comparing, creating explanations, and communicating. The proposed scenario may last up to five didactic hours.

The curriculum area and pedagogic activities of the scenario are the following:

3.1. Curriculum area

Subject/discipline area: Physics education; The objective purpose of physics education is to familiarize students with physical phenomena.

Context/level of study: Senior High school or Technical High School. The scenario is implemented in the penultimate grade of the Senior High School; students are 16-18 years old. A class of 21 to 24 students may participate in the scenario implementation (6 to 7 student teams).

Topic/domain: Simple Electric Circuits (chapter 2 of the national course book; it includes the following subchapters: 1. Ohm's law, 2. Series circuits, 3. Parallel circuits, 4. Series-Parallel combination circuits)

Pre-requisite skills/ knowledge: Learners should be able to improve their own learning and performance, solve problems, and work with other learners. They must know to solve simple mathematical equations in the form of $ay+bx = c$ and draw graphs.

3.2. Pedagogic Activities

Learning tasks/activities: Teacher initiates students to what he or she is going to teach through an introductory discussion. He/She uses the CircuitMaker software and five organized activities.

Learning objectives/outcomes

- Learn about operational differences between series, parallel, and combination resistance circuits.
- Learn to predict outcomes and draw conclusions.
- Learn about teamwork and working in teams.
- Learn that different circuit designs result in different electrical behaviours.
- Raise learners' interest towards the electric circuit investigation and discovery principles and concepts through inquiry-based simulations, explorations, and guided discovery.
- After testing several predictions about each circuit type, the teams will compare results and discuss findings.
- In general, students learn how to learn.

Tools/ Resources: Traditional course book, CircuitMaker software, Worksheets of activities, Whiteboard.

Assessment Strategy : Oral questioning and discussion between student teams and teacher.

Time allocated: Up to five didactic hours.

The worksheets of the activities were created based upon the following National Science Education Standards (Olson and Loucks-Horsley, 2000):

- the material provides a sequence of learning activities connected in such a way as to help students build abilities of inquiry, understandings of inquiry, and/or fundamental science subject matter concepts, and specific means (e.g., connections among activities, building from concrete to abstract, and embedded assessments) to help the teacher keep students focused on the purpose of the lesson,
- the teacher's guide present common student difficulties in learning inquiry abilities and understandings,
- there are suggestions provided to access prior abilities and understandings of students,
- opportunities for students are given to demonstrate the same understandings as part of their investigations.

The instructor and tutors monitor the progress of the teams and provide assistance only when requested. Students are encouraged to discover concepts and formulas through experimentations, observations and inquires, and in turn, use what they discovered, to solve challenging problems.

3.3 Activities

General Directions: You will need the CircuitMaker software (Student Edition) for these assignments. Use the guides of the worksheets to answer the questions. Observe the experimentations and save your experimental findings in your notebook so that you can use that information for analyzing them, drawing the graphs, etc. Use scientific criteria to analyze alternative explanations. Discuss with your partners of both roles and limitations of skills such as organizing and interpreting data, and constructing explanations. You should work in teams of three (recommended) or four members.

3.3.1 Activity 1

Title: Ohm's law

Lesson Focus: Discovery of Ohm's law by using inductive reasoning.

Lesson Synopsis: This activity encourages student teams to experiment, observe, make tentative hypothesis, gather and interpret data as well as to use the data in drawing graphs, and formulate the theory of Ohm's law by using inductive reasoning.

Prerequisites: Concepts of Voltage, Current, and Resistance. Graph of linear equation. Knowing of inductive reasoning.

Worksheet 1

1. Make the following simulation in the CircuitMaker software, vary the value of the voltage of the source Vs1 from 0 to 10 with a step of 2, complete the Table 1, and answer the questions below.

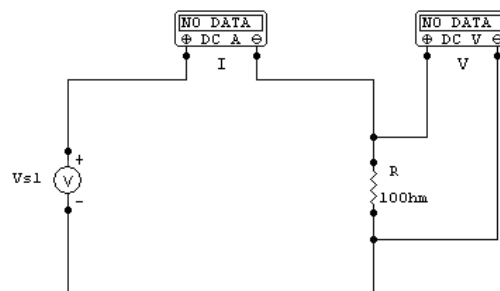

Table 1. Results of the Activity 1

V [DC V]	I [DC A]
0	
2	
4	
6	
8	
10	

Exploratory Questions

- Do the values of the quantities V and I in the Table 1 vary in a linear way? If yes, what kind of mathematical equation is it?
- Draw a graph next to the graph of linear equation of the Fig. 1 by using your measurements in the Table 1, and answer the questions below.

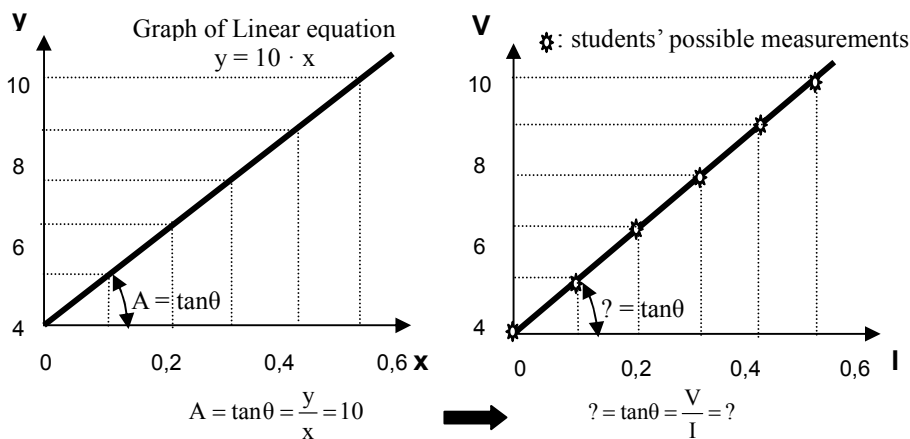

Figure 1. Examination if the two graphs have the same $\tan\theta$

Exploratory Questions

- Are the graphs similar? (examine if the graphs have the same $\tan\theta$).
- If the $\tan\theta$ is the same in both of graphs, which is the relation between the resistance R and A?
- A tentative hypothesis is that the $R = \tan\theta = V/I$ is applied for all the values of the resistance R. Repeat the steps 1 and 2 for the values 5 Ohm and 25 Ohm of the resistance R, and answer the questions below.

Exploratory Questions

- Is the resistance R equal to $\tan\theta$ in all three graphs?
- Which is the relationship among the voltage(V), current(I), and resistance(R) for the values of resistance 5, 10, and 25 Ohm?
- Use inductive reasoning to generalize the relationship among the voltage(V), current(I), and resistance(R). This law of the simple electric circuit is the Ohm's Law.

3.3.2 Activity 2

Title: Series circuits

Lesson Focus: Discovery of formulas and principles of series circuits.

Lesson Synopsis: This activity encourages students to test two different circuit designs (a simple electric circuit versus a serial circuit). Students work in teams to find out similarities and differences between the two circuit designs by comparing them in order to discover the principles and formulas of the new circuit.

Prerequisites: Ohm's law.

Worksheet 2

1. Make the following simulations of the circuits A and B.

Circuit A

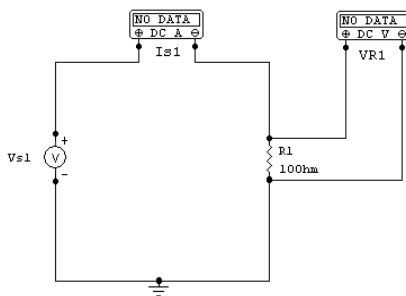

Circuit B

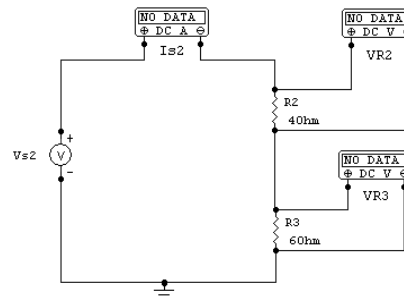

2. Make predictions about the values of I_{s1} , $VR1$, I_{s2} , $VR2$, and $VR3$ if both values of the voltages V_{s1} and V_{s2} are 10V.
3. Vary the value of the voltage of both sources V_{s1} and V_{s2} from 0 to 10 with a step of 2, complete the Table 2, and answer the questions below.

Table 2. Results of the Activity 2

V_{s1}	I_{s1}	$VR1$	V_{s2}	I_{s2}	$I_{s2} \cdot R_2$	$I_{s2} \cdot R_3$	$VR2$	$VR3$
0			0					
2			2					
4			4					
6			6					
8			8					
10			10					

Exploratory Questions

- a. For the same voltage of both sources V_{s1} and V_{s2} of the two circuits A and B, do you observe the same current I_{s1} and I_{s2} , respectively? If yes, what can we conclude about the total (or equivalent) resistance of the circuit B? Which is the formula calculating the total resistance in series circuits?
- b. Use inductive reasoning to generalize the formula of the total resistance in series circuits with more than two resistances.
- c. For each value of the voltage of the source V_{s2} which is the sum of $VR2$ (voltage drop across the resistance R_2) and $VR3$ (voltage drop across the resistance R_3)? What can we conclude about the relationship among the voltages V_{s2} , $VR2$, and $VR3$?
- d. Use inductive reasoning to generalize the equation connecting the voltage V_{s2} with the voltage drops across the resistances in series circuits with more than two resistances.
- e. Compare the relationship between the $I_{s2} \cdot R_2$ and $VR2$, as well as between the $I_{s2} \cdot R_3$ and $VR3$. What can we conclude about this comparison? How to calculate the voltage drop across series resistances?
- f. Use inductive reasoning to generalize the formula calculating the voltage drop across resistances in circuits with more than two resistances in series.

3.3.3 Activity 3

Title: Parallel circuits

Lesson Focus: Discovery of formulas and principles of the parallel circuits.

Lesson Synopsis: This activity encourages students to test two different circuit designs (a simple electric circuit versus a parallel circuit). Students work in teams to find out the similarities and differences between the two circuit designs, by comparing them, in order to discover the principles and formulas of the new circuit.

Prerequisites: Ohm's law.

Worksheet 3

1. Make the following simulations of the circuits A and B.

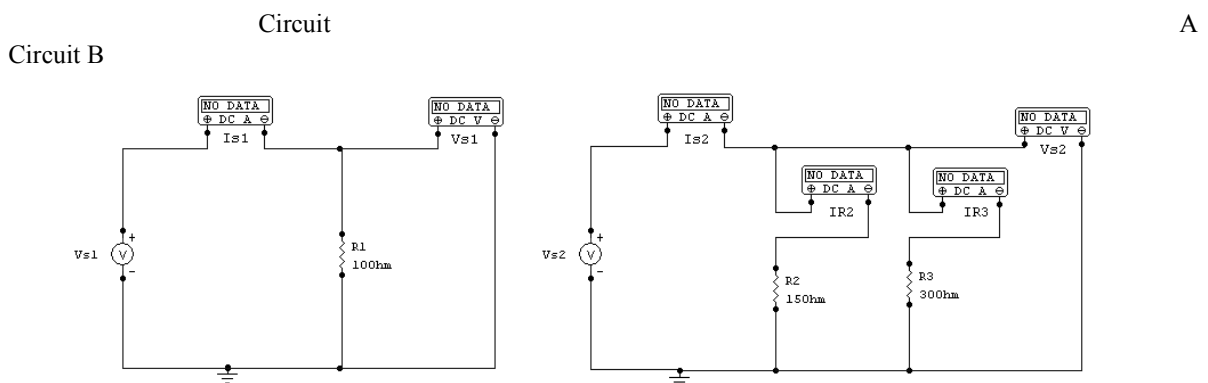

- Make predictions about the values of I_{s1} , V_{R1} , I_{s2} , V_{R2} , I_{R2} , I_{R3} if both values of the voltages V_{s1} and V_{s2} are 10V.
- Vary the value of the voltage of both sources V_{s1} and V_{s2} from 0 to 10 with a step of 2, complete the Table 3, and answer the questions below.

Table 3. Results of the Activity 3

V_{s1}	I_{s1}	V_{s2}	I_{s2}	I_{R2}	$I_{R2} * R_2$	I_{R3}	$I_{R3} * R_3$
0		0					
2		2					
4		4					
6		6					
8		8					
10		10					

Exploratory Questions

- For the same voltage of both sources V_{s1} and V_{s2} , of the two circuits A and B, do you observe the same currents (I_{s1} and I_{s2} , respectively)? If yes, what can we conclude about the total (or equivalent) resistance of the circuit B? Examine which of the following four formulas calculates the total resistance in circuits with two resistances in parallel.

$$a_1: R_{tot} = R_2 * R_3, a_2: R_{tot} = R_2 / R_3, a_3 = \frac{1}{R_{tot}} = \frac{1}{R_2} - \frac{1}{R_3}, a_4 = \frac{1}{R_{tot}} = \frac{1}{R_2} + \frac{1}{R_3} \text{ or } R_{tot} = \frac{R_2 * R_3}{R_2 + R_3}$$

- Use inductive reasoning to generalize the formula of the total resistance in circuits with more than two resistances in parallel.

- c. For each value of the current I_{s2} which is the sum of I_{R2} (current flowing through the resistance $R2$) and I_{R3} (current flowing through the resistance $R3$)? What can we conclude about the relationship among the currents I_{s2} , I_{R2} , and I_{R3} ?
- d. Use inductive reasoning to generalize the equation connecting the current I_{s2} with the currents flowing through the resistances in circuits with more than two resistances in parallel.
- e. Compare the relationship between the $I_{R2} \cdot R2$ and V_{s2} , as well as between the $I_{R3} \cdot R3$ and V_{s2} . What can we conclude about this comparison?

3.3.4 Activity 4

Title: Combination circuits

Lesson Focus: Discovery of formulas and principles of the combination of series and parallel circuits.

Lesson Synopsis: This activity encourages students to test two different circuit designs (a series circuit versus a combination of two parallel resistances in series with a third resistance, and a combination of two serial resistances in parallel with a third resistance). Students work in teams to find out the differences and similarities between the two circuit designs, by comparing, them, in order to discover the principles and formulas of the new circuit.

Prerequisites: Ohm's law, series and parallel circuits.

Worksheet 4

1. Make the following simulations of the circuits A and B.

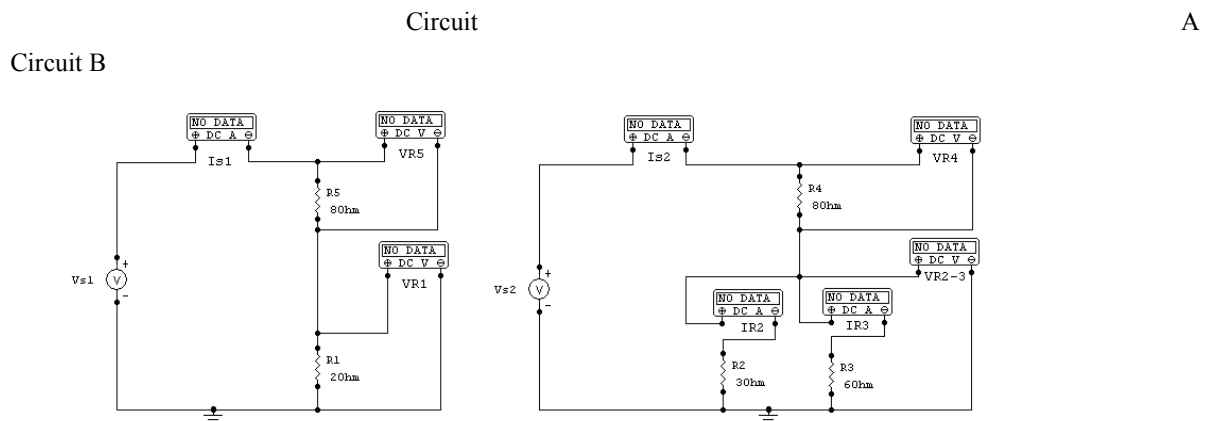

2. Make predictions about the values of I_{s1} , I_{s2} , I_{R2} , I_{R3} , V_{R1} , V_{R5} , V_{R2-3} , and V_{R4} if both of the values of the voltages V_{s1} and V_{s2} are 10V.
3. Vary the value of the voltage of both sources V_{s1} and V_{s2} from 0 to 10 with a step of 2, complete the Table 4, and answer the questions below.

Exploratory Questions

- a. For the same voltage of both sources V_{s1} and V_{s2} , of the two circuits A and B, do you observe the same currents (I_{s1} and I_{s2} , respectively)? If yes, what can we conclude about the total (or equivalent) resistance of the circuit B? Which is the formula calculating the total resistance of the circuit B?
- b. For the same value of the voltage of both sources V_{s1} and V_{s2} , of the two circuits A and B, do you observe that both voltages of V_{R5} and V_{R4} have the same value, as well as that both voltages of V_{R1} and V_{R2-3} have the same value?

- c. For each value of the current I_{s2} , which is the sum of I_{R2} (current flowing through the resistance R_2) and I_{R3} (current flowing through the resistance R_3)? What can we conclude about the relationship among the currents I_{s2} , I_{R2} , and I_{R3} ?
- d. Compare the relationship among the voltages of V_{s1} , V_{R1} , and V_{R5} , as well as among the voltages of V_{s2} , V_{R2-3} , and V_{R4} for all the values of the table 4. What can we conclude about this comparison?

Table 4. Results of the Activity 4

V_{s1}	I_{s1}	V_{R1}	V_{R5}	V_{s2}	I_{s2}	I_{R2}	I_{R3}	V_{R2-3}	V_{R4}
0				0					
2				2					
4				4					
6				6					
8				8					
10				10					

4. Make the following simulations of the circuits A and B.

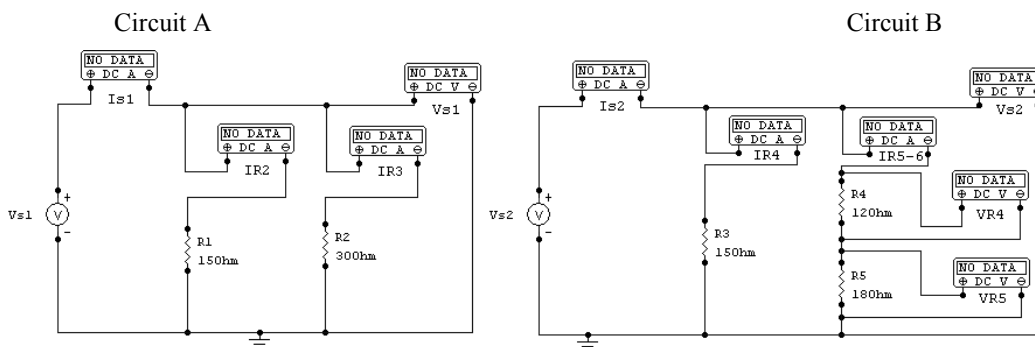

5. Make predictions about the values of I_{s1} , I_{s2} , I_{R2} , I_{R3} , I_{R4} , I_{R5-6} , V_{R4} , and V_{R5} if both of the values of the voltages V_{s1} and V_{s2} are 10V.
6. Make exploratory questions, such as above, in order to explore the simulations and decide about the formulas and principles of the circuit B by comparing it with the circuit A.

3.3.5 Activity 5

Title: Open-ended problem about electrical circuits.

Lesson Focus: Students use the knowledge about electrical circuits, obtained until now, to solve an open-ended problem. Also, they should be able to restrict the number of solutions of the problem. This activity should be better to be taught by using the brainstorming technique.

Lesson Synopsis: This activity encourages students to solve open-ended problems by dividing them into sub-problems. Dividing the problem into sub-problems is an effective strategy for constructing the solution. Thus, the solution process involves repeated applications of the following two steps: (i) choosing some useful sub-problems, and (ii) carrying out the solution of these sub-problems. These steps can then be recursively repeated until the original problem has been solved. The decisions needed to solve a problem arisen from choosing sub-problems (Gök, 2010).

Prerequisites: Series, Parallel, and Combination of resistance circuits.

Worksheet 5

Problem definition: How many ways can we connect the resistances $R_1=20\Omega$, $R_2=30\Omega$, and $R_3=60\Omega$?

Problem restrictions: In order to restrict the number of solutions of the problem, we should modify the problem so that it to give the lower limit of solutions. In your opinion, which of the modifications below may assist you to restrict the

number of solutions of the problem to the lower limit?

- a. How many ways can we connect the resistances $R_1=2\text{Ohm}$, $R_2=3\text{Ohm}$, and $R_3=6\text{Ohm}$ so that each of the possible connections to give the same total resistance?
- b. How many ways can we connect the resistances $R_1=2\text{Ohm}$, $R_2=3\text{Ohm}$, and $R_3=6\text{Ohm}$ so that each of the possible connections to give different total resistance?
- c. How many ways can we connect the resistances $R_1=2\text{Ohm}$, $R_2=3\text{Ohm}$, and $R_3=6\text{Ohm}$ so that each of the possible connections to give one only value to the total resistance?

Division of the problem into sub-problems: For the case (b) of the above modifications, divide the problem into four sub-problems. For example, one sub-problem should examine the solutions of series circuits. In this case, you should find out the possible solutions before and after the restrictions.

Decision making and criteria judging the best solutions: For the case (b) of the above modifications of the initial problem, the criteria for judging which solutions best solve the problem are the following:

Sub-problem1: For series resistances it should be possible to give one only solution among equivalent possible solutions (weight=25%).

Sub-problem2: For parallel resistances it should be possible to give one only solution among equivalent possible solutions (weight=25%).

Sub-problem3: For two series resistances in parallel with the third one, it should be possible to give three solutions among equivalent possible solutions (weight=25%).

Sub-problem4: For two parallel resistances in series with the third one, it should be possible to give three solutions among equivalent possible solutions (weight=25%).

The idea with the highest score will best solve the problem. But, you should keep a record of all of your best ideas and their scores in case your best idea turns out not to be workable.

4. Conclusion

In this paper a scenario framework and its application in the curriculum of Senior High Schools or Technical High Schools is described. The presented scenario framework begins with exploratory activities on simple electrical circuits and finishes with an open-ended problem solving activity. This scenario aims at the development of exploratory and critical thinking of students, the development of make-decision skills and knowledge transfer skills from one framework to another, the ability of collaboration and in common approach of problem solving. Moreover, this scenario helps the students construct and co-construct their own deep understanding and knowledge on electrical circuits through inquiry-based simulations, explorations, guided discovery, collaboration, and by comparing a known with an unknown electrical circuit as well. In this way, the students discover principles and formulas of the unknown electrical circuits. The role of the student teams is very important for the improvement of each student achievement. This scenario framework is a difficult, too bold but not out of reach scenario. Nevertheless, it has adopted and applied by educators with a great success. The enthusiasm of the participants was apparent.

5. References

- Abdullah, S. and Shariff, A. (2008). The effects of inquiry-based computer simulation with cooperative learning on scientific thinking and conceptual understanding of gas laws. *Eurasia Journal of Mathematics, Science and Technology Education*, 4(4), 387-398.
- Baker, D.P., Day, R., and Salas E. (2006). Teamwork as an essential component of high-reliability organizations. *Health Serv Res.* 41(42), 1576-1598.
- Barkley, E., Cross, P., & Major, C. (2005). *Cooperative Learning Techniques*. San Francisco: Jossey-Bass.
- Buffler, A. and Allie, S. (1993). Towards an active learning environment in physics: developing problem solving skills through cooperative learning. In Proceedings of the Annual Conference of the South African Association of Academic

Development, Bellville, 15-29.

Carroll M. J. (1999). Five Reasons for Scenario-based Design, Proc. of the 32nd Hawaii International Conference on System Sciences, 3.

Chi, M.T.H. (2008). Three types of conceptual change: Belief revision, mental model transformation, and categorical shift. In S. Vosniadou (ed.), *Handbook of research on conceptual change* (61-82). Hillsdale, NJ: Erlbaum.

Concari, S., Giorgi, S., Cámara, C., and Giacosa, N. (2006). Instructional Strategies Using Simulations for Physics Teaching. *Journal of Current Developments in Technology-Assisted Education*, 2042-2046.

Crook, C. (1994). *Computers and the Cooperative Experiences of Learning*. London: Routledge.

DiSessa, A. (2001). *Changing Minds: Computers, Learning, and Literacy*. Cambridge: MIT Press.

Duit, R. & von Rhöneck, C. (1998). Learning and understanding key concepts of electricity. In A. Tiberghien, E.J. Jossem & J. Barajos (eds.) *Connecting research in physics education with teacher education*.

Gök, T. (2010). A new approach: Computer-assisted problem-solving systems. *Asia-Pacific Forum on Science Learning and Teaching*, 11(2).

Heller, P., & Hollabaugh, M., (1992). Teaching problem solving through cooperative teaming. Part 2: Designing problems and structuring teams, *American Journal of Physics*, **60**, 637-644.

Hung, D. & Chen, D. (2002). Two kinds of scaffolding: The dialectical process within the authenticity-generalizability (A-G) continuum. *Education Technology & Society*, **5**(4), 148-153.

Johnson, D. W., Johnson, R.T. (1989). *Cooperation & Competition: Theory and research*. Edina, MN: International Book Company.

Lee, V. S. (1999). Creating a Blueprint for the Constructivist Classroom. *The National Teaching and Learning Forum*, **8**(4), 1-4.

Lombardi, M.M, (2007). Authentic Learning for the 21st Century: An Overview. ELI's 2007 series on authentic learning. Educauce learning Initiative.

Maloney, D.P. (1994). Research on Problem Solving: Physics. *Handbook of Research in Science Teaching and Learning*, D.L. Gabel, (Ed.). New York: Macmillan. 327-354.

McDermott, L. & Shaffer, P. (1992). Research as a guide for curriculum development: An example from introductory electricity. *American journal of physics*, **60**(11), 994-1013.

Michaelsen, L. K., Fink, L. D. & Knight, A. (1997). Designing effective team activities: Lessons for classroom teaching and faculty development. In D. DeZure (ed.), *To improve the academy: Resources for faculty, instructional, and organizational development*, Stillwater, OK: New Forums Press, **16**, 373-397.

Oakley, B, Felder, R.M, Brent, R., & Elhadj, E. (2004). Turning student teams into effective teams. *Journal of Student Centered Learning*, **2**(1), 9-34.

Olson, S. and Loucks-Horsley, S. (eds). (2000). *Inquiry and the National Science Education Standards: A Guide for Teaching and Learning*. Copyright © National Academy of Sciences. All rights reserved.

Reif, F. & Scott, L.A. (1999). Teaching scientific thinking skills: Students and computers Coaching each other. *American Journal of Physics*, **67**, 819-831.

Ronen, M. & Eliahu, M. (2000). Simulation. A bridge between theory and reality: The case of electric circuits. *Journal of computer assisted learning*, **16**(1), 14-26.

Rosenshine, B. & Meister, C. (1992). The use of scaffolds for teaching higher level cognitive strategies. *Educational Leadership*, 26-33.

Snowman, J., McCown, R., & Biehler, R. (2008). *Psychology Applied to Teaching*. (12th ed.)

Tao, P-K., & Gunstone, R.F. (1999). Conceptual Change in Science through Cooperative Learning at the Computer. *International Journal of Science Education*. **21**(1), 39-57.

Vygotsky, L. (1978). *Mind in society: The development of higher psychological processes*. Cambridge, Mass: Harvard

University Press. Wadsworth Publishing Company.

Wang, T. & Andre, T. (1991). Conceptual change text versus traditional text and application questions versus no questions in learning about electricity. *Contemporary educational psychology*, **16**, 103-116.

This academic article was published by The International Institute for Science, Technology and Education (IISTE). The IISTE is a pioneer in the Open Access Publishing service based in the U.S. and Europe. The aim of the institute is Accelerating Global Knowledge Sharing.

More information about the publisher can be found in the IISTE's homepage:

<http://www.iiste.org>

The IISTE is currently hosting more than 30 peer-reviewed academic journals and collaborating with academic institutions around the world. **Prospective authors of IISTE journals can find the submission instruction on the following page:**

<http://www.iiste.org/Journals/>

The IISTE editorial team promises to review and publish all the qualified submissions in a fast manner. All the journals articles are available online to the readers all over the world without financial, legal, or technical barriers other than those inseparable from gaining access to the internet itself. Printed version of the journals is also available upon request of readers and authors.

IISTE Knowledge Sharing Partners

EBSCO, Index Copernicus, Ulrich's Periodicals Directory, JournalTOCS, PKP Open Archives Harvester, Bielefeld Academic Search Engine, Elektronische Zeitschriftenbibliothek EZB, Open J-Gate, OCLC WorldCat, Universe Digital Library, NewJour, Google Scholar

