

## Job Satisfaction and Productivity of the Factory Offices of the Tea Plantation Sector in Sri Lanka

Kuranage Anton Rohan Christin Perera<sup>1</sup> Ali Khatibi<sup>2</sup> Suranga Silva<sup>3</sup> Isuri Dharmarathna<sup>4</sup>

1. Reading for PhD at Management and Science University Colombo Branch – Sri Lanka

2. Management & Science University – Malaysia

3. University of Colombo, Sri Lanka

4. Business Management School (BMS) – Sri Lanka

### Abstract

Ceylon Tea which is a world renowned brand name celebrates the 150<sup>th</sup> year since the planting of the first tree by a British national in the Loolekandura Estate in the Central Hills of the country. This research Paper is to analyze the Factory Employees' Job Satisfaction and Productivity of the Sri Lankan Plantation Sector in Sri Lanka. Job Satisfaction and Productivity are widely spoken topics of the many other fields of the international forums and journals. Four hundred questionnaires were distributed among the Factory Officers of the Tea Estates. The response to four hundred questionnaires distributed among the factory employees, 370 were returned and the response rate was 92.5 percent. The data was analyzed by using descriptive analysis and structural equation methods. The findings show that job satisfaction has a significant positive impact on productivity.

### Introduction

Sri Lankan Tea Plantations are going through a period of upheavals since independence. Most of the difficulties of Sri Lankan Plantations could be attributed to the change of government, unwise political decisions of the opportunistic politicians, disturbances of the world markets, disputes among various countries, spreading wars in countries who are the main buyers of Ceylon tea, unkindly weather patterns and serious price fluctuations in the financial markets here and abroad.

Productivity can be enhanced by reducing unit cost and increasing output. Another name for reducing unit cost of production is productivity. There are several factors which help to reduce unit cost. Above mentioned factors are: controlling wages, unionism and current wages are below market rate, plucking average is less, ineffective management decisions on maintenance, fertilizer, plant types and ageing plants, deficiency in labour productivity, land productivity and plucking productivity, soil erosion leading to infertile soil, pests and diseases, weak strategies and structures, lack of managerial and technical personnel and unmatched plant types and decreasing yield/ha. The high labour cost is mainly due to work norms such as plucking, pruning, draining, fertilizer use and planting being below the worker capacity. By remedying the grievances such as encouraging people to live in the estate plantation sector, improve the health and other basic infrastructure facilities, entertaining the workers who are outside the plantation, restructuring the current wage scales, taking measures to discourage turnover of the employees and taking measures to stop anemia (worm responsible for this sickness enters through the sole of the foot) by wearing slippers could be some of the important measures needed to be introduced to increase the productivity of the tea sector (Perera, M., 2017; Verite Research, 2016). Since the time of Colonial era, the hierarchical structure of the plantation sector is divided into five levels and they are namely the entrepreneur, management, staff (clerical and white color), sub staff (supervisors, drivers, mechanics, creche attendants) and labourers. The factory managers about whom this research is carried out belongs to the sub staff category (Perera, M., 2017).

Some parts of the world, there are enough and more articles have been written on the variables of Job Satisfaction and Productivity. The purpose of this paper is to revisit those research in the context of the Tea Plantation in Sri Lanka.

### Literature Review

#### Job Satisfaction

According to Vroom (1964) Job satisfaction is an emotional orientation and performing a task at the working place owned by the workers towards the role they are performing at the work place. Job Satisfaction compels the workers induced by motivation and encouragement for better performance. Hoppok & Spielgler (1938) defines job satisfaction as an integrated dimension of psychological, physiological and environmental situations that compels the workers to accept that they are happy with their given task. Clark (1997) argues that "if employees are not satisfied with the task assigned to them, they are not certain about factors such as their rights, working conditions are unsafe, co-workers are not cooperative, supervisor is not giving them due respect and they are not considered in the decision-making process; resulting them to feel separate from the organization". The workers with less morale make less effort to improve the situation as a result in order to rectify the situation their morale needs to be maintained high. Job Satisfaction as the integrated set of psychological, physiological and

environmental conditions that compel the employees that they are alright and joyful about their jobs (Hoppok & Spielgler: 1938).

### **Productivity**

Prokopenko (1992) quoted in Dugguh (2014) says that productivity has been defined by the International Labor Organization (ILO) as “the effective and efficient use of all resources, capital, labor, material, information and time.” The reasons which hinder the productivity are low productivity of labor which is measured through some of the indices such as poor quality of local products, which is becoming a stumbling block for exportation, thereby difficulty in competing with other competitors in the market, unfavorable trade deficit in the balance, hindrances lays on the movement of the laborers and shortage and surplus of employees, use of old technology occasioned by low labor mobility or existence of surpluses and deficits of employees, use of out dated technology, inadequate access to basic needs and necessities of life, generally poor physical and mental health conditions of the populace, poor human resource management and weak industrial relations. Therefore, enhancing productivity is a must in the national development schemes.

Wazed and Ahmed (2008) quoted in Gupta & Dey (2010) say that “basic content of definitions of productivity are the same but within similar definitions there are three broad categorizations namely 1. The technological concept: the relationship between ratios of output to the inputs used in its productivity; 2. The engineering concept; the relationship between the actual and the potential output of a process; and 3. The economist concept: the efficiency of resource allocation.”

### **Job Satisfaction and Productivity**

Some of the most popular measures in the field, e.g. the Job Descriptive Index (Smith et al., 1969), the Minnesota Satisfaction Questionnaire (Weiss et al., 1967), the Job Satisfaction Survey (Spector, 1985) have adopted this perspective but fairly a good number of job satisfaction studies have found using MSQ as a basis for this research. Weiss et al further says that the Minnesota Satisfaction Questionnaire was one of the outputs from the “Work Adjustment Project” at the University of Minnesota and the underlying theory is based on the assumption that work fit is dependent on the correspondence between the individual skills and the reinforcements that exist in the work environment (Weiss et al., 1967). This is suitable for individuals of all school levels that can be administrated separately or individually but this is a self-reporting measure. Edward, *et al.* 2008 quoted in Perera, G, D, N (2014) presents the several questionnaire models presents to us and they are namely - Minnesota Satisfaction Questionnaire (MSQ) developed by Weiss, *et al.* in 1967, Job Descriptive Index (JDI) developed by Smith *et al.* 1969, Job Characteristics Model (JCM) explained by Hackman and Oldham, 1976 (Edward, *et al.* 2008).

Bockerman, P & Illmakunas (2014) on the basis of results of their research on job satisfaction of the European Community Household Panel (ECHP) on establishment productivity from longitudinal register data that the effect of an increase in the establishment’s average amount of employee job satisfaction is positive.

Halkos, G.M. & Bousinakis, D (2012) reveals that during the neo-classical period (1920-1950) believed that employee satisfaction mainly influences productivity. It was found out that cause-effect relationship existed between satisfaction and productivity. As a result of it, various institutions find out various means in order to increase productivity. Nouri, B. & Wael, J (2011) found out through their research that Job satisfaction leads to employee productivity.

### **Research Design**

This study is to examine the impact of job satisfaction on the productivity of the Tea Plantation in Sri Lanka. While this study is descriptive in nature the unit of analysis is factory officers of the plantation sector. As factory officers are eligible to read and write self-administered questionnaire was served to them and they are the very unit of study. According to Roscoe (1975) sample larger than 30 and less than 500 are appropriate for most researches. Four hundred questionnaires were distributed among the employees and 370 were returned. Disproportionate random sampling method was implemented. Outliers were checked and with the help of whisker diagram, box plot, stem and leaf plot. As a result of it, it was found that 8 outliers and these outliers were removed and the number of questionnaires subjected to analytical part was 362.

### **Operationalization of Variables.**

#### **Job Satisfaction (JS)**

Weiss, *et al.* (1967) give 22 items of construct on job satisfaction (JS). There are four constructs for JS and they are namely the work itself (WI), pay (PA), supervision (SU) and working condition (WC). Under each construct several sub constructs could be seen. There are five sub constructs under work itself and the constructs such as pay, supervision, and working condition has four sub constructs for each category. Each sub construct under main construct was measured using five-point Likert scale assigning values number one to five. Number

one to five stands for strongly disagree to strongly agree respectively.

### Productivity (PR)

Dey, S. K and Gupta, R (2012) has introduced several constructs for PR and they are namely 1) capital investments in production, 2) capital investments in technology, 3) capital investments in equipment, 4) capital investments in facilities, 5) economies of scale, 6) workforce knowledge and skill resulting from training and experience, 7) technological changes, 8) work methods, 9) procedures, 10) systems, 11) quality of products, 12) quality of processes, 13) quality of management, 14) legislative and regulatory environment, 15) general levels of education, 16) social environment and 17) geographic factors.” The same seven dimensions have been used by Nath, A. K &, Dutta, A.K ;2015, Dey, S.K & Gupta, R ;2012, to examine and analyze Productivity. The perception of the productivity is investigated by referring to the questionnaire model of Gupta, R and Dey, S.K (2010) and Yogarathnam (2011).

For this study, the main construct PR was studied by three domains such as Labour Input – Wage (LIW) consisting first 7 sub constructs from the above constructs (1 to 7), Labour Input-Capital (LIC) consisting 6 constructs from above constructs (8 to 13) and Material Input (MI) construct consisting four sub constructs from the above (14 to 17) were being put. Five-point Likert scale has been used and one stands for strongly disagree and five stands for strongly agree.

### Assessment of Normality

Chinna, (2013) expresses that Skewness and kurtosis were used to check the normality of the data. Skewness should not exceed more than three in one hand and on the other hand kurtosis values should not exceed ten at all (Kline, 2005). Univariate normality of the data is existing as the skewness and kurtosis values of this mini research remain within the ambit of approved amounts as suggested by studies (Table 1).

Table 1: Assessment of normality

Variable	Minimum	Maximum	Skewness	Std. Error	Kurtosis	Std. Error
JS	1	5	-1.250	0.128	0.724	0.256
PR	1	5	-0.814	0.128	-0.190	0.256

### Validation of Measurement Properties

The analysis of moment of structures (AMOS) as a confirmatory factor analysis in structural equation modeling (SEM) to evaluate the job satisfaction and productivity. The Cronbach’s alpha to remain at least 0.70 and inter item correlation needs to be at the level of more than 0.30 give the stability for the items in the construct (Chinna, 2013; De Vellis, 2003).

Table 2: Reliability test for first order factors

Construct	# of items before dropped	# of items after dropped	Cronbatch Alpha after dropped	KMO after dropped
Work Itself	5	4	0.894	0.818
Pay	4	4	0.896	0.846
Supervision	4	4	0.894	0.805
Working Condition	4	4	0.896	0.822
Labour Input – Wage	7	5	0.899	0.876
Labour Input – Capital	6	5	0.888	0.878
Material Input	4	4	0.853	0.821

After developing the reliability test, the CFA is done for job satisfaction and productivity factors. After dropping, 1 item each from work itself and labour input-capital and 2 items from labour-input wage. The AMOS programme used only 30 items. The chi-square divided by degree of freedom ( $\chi^2 / df$ ), Goodness of Fit Index (GFI), Adjusted Goodness of Fit Index (AGFI), Comparative Fit Index (CFI), Tucker-Lewis Index (TLI) and Root Mean Squared Approximation of Error (RMSEA) used for to check the model fit. These results also demonstrate that structural model is the best of the data (Hair, et al.1998; Kline, 2005, Byrne, B.M., ;2016, Chinna; 2017). The initial measurement model for the job satisfaction and productivity was developed and shown in figure 1.

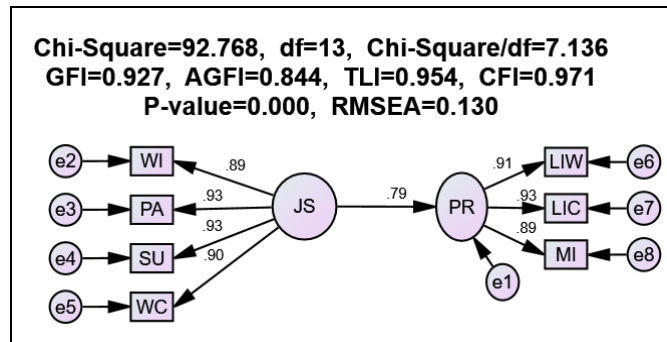

Figure 1: Initial measurement model for job satisfaction and productivity

According to the initial measurement of the JS and PR (Figure 1), factor loading of all items were above the minimum cutoff point 0.5; hence there was no need to drop any item of the construct. Examination of all the fit indices for this construct revealed that the CFA model of the construct (Figure 1) not satisfying the all of fit conditions: Chi-square/df = 7.136 which was greater than the cutoff value 3, GFI=0.927; AGFI=0.944; CFI=0.971; TLI=0.954; and RMSEA=0.130 which was also greater than cutoff value 0.08 (Hair, *et al.*2006).

Modification indices showed that the final model (Figure 2) can be improved by allowing correlation of the items WI and WC in JS as well as LIW and LIC in PR. Then the final model of the JS and PR aligned with the data evidenced by the chi-square/df=1.669, GFI=0.986, AGFI=0.963, CFI=0.997 and TLI=0.995 were above the desired level of 0.9, whilst RMSEA=0.043 was below the required level of 0.08. Further, factor loading of all the items were above 0.5 indicating adequate individual item reliability.

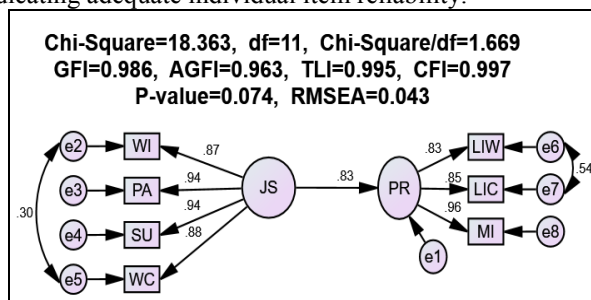

Figure 2: Final measurement model for JS and PR

From the final model all relationships were statistically significant. The regression weights for the final structural model presented in Table 3.

Fit indices in Table 3 demonstrate good fitness of both variables, proving that the selected indicators are good representatives for each dimensions of job satisfaction and productivity which indicate that all scales exhibit validity which is good.

Table 3: Regression weights and reliabilities of the final structural model

Path	Unstd. Estimate	S.E	C.R	P	Std. Estimate	AVE	CR
PR<--- JS	0.779	0.050	15.710	***	0.825		
WC<--- JS	1.000				0.880		
SU<--- JS	1.069	0.038	27.880	***	0.940		
PA<--- JS	1.072	0.038	27.972	***	0.941		
WI<--- JS	0.989	0.035	28.189	***	0.869	0.833	0.952
LIW<--- PR	1.000				0.826		
LIC<--- PR	1.017	0.035	29.118	***	0.847		
MI<--- PR	1.128	0.053	21.255	***	0.957	0.823	0.933

\*\*\* P < 0.001

The verification of the multivariate normality for the items of job satisfaction and productivity were done. The Assumption of multivariate normality is not met because the critical ratio value for multivariate kurtosis = 16.273 which was more than 5. As a result of testing on 1000 bootstrap resample the Bollen-stine p value was 0.226, which has gone beyond 0.05. Therefore, the model is admitted as correct. The standardized residual covariances have less than two in absolute value and the model is correct (Kline;2005). By analyzing the Mahalanobis distance p1 is more than 0.001, the observation is not an outlier and the highest distance is 46.207.

The Composite Reliability (CR) was 0.6 and Average Variance Extracted (AVE) was 0.5 for the final structural model items (Table 3). As Hair, *et al.* (2010), Chinna (2013) convergent validity exists when the AVE value is greater than 0.5 and CR value is greater than AVE.

Further Table 4, narrates according to Fornell and Larcker (1981); Chinna, (2013) the AVE is much more

than the all corresponding construct correlations ( $R^2$ ), which is a clear proof and an evidence of discriminant validity of the construct.

Table 4: Discriminant validity

	JS	PR
JS	0.833*	
PR	0.681**	0.823*

\* AVE, \*\*  $R^2$

### Conclusion and Recommendations

Overall results of this study prove that job satisfaction is positively and significantly influence productivity. Therefore, results of the objective showed that job satisfaction is positively and significantly influence productivity. Therefore, results of this study show that when the factory officers are satisfied, they will improve the productivity of the Tea sector in Sri Lanka. Lower job satisfaction causes secretly deceleration of the works, job success and job productivity and increases in the workforce turnover (Iverson and Deery, 2007; Lum, 2006), occupational accidents and complaints. Job satisfaction can be described as one's feelings or state of mind regarding the nature of the work and Job satisfaction can be influenced by a variety of factors such as the quality of the academics' relationships with their supervisors, the quality of the physical environment in which they work and the degree of fulfillment in their work (Lambert, Pasupuleti, Cluse-Tolar and Jennings, 2008). Job satisfaction remains a key factor in productivity (Oshagbemi, 2000). Taking all these factors into consideration job satisfaction is very important in an organization because if employees are not satisfied, their work performance, productivity, commitment as well as the interpersonal relationships among the management and their subordinates tend to reduce (Fajana, 1996).

### References

- Bockerman, P & Illmakunas (2014). ILR Review, SAGE Publication. Vol. 65. No.2.
- Byrne, B.M., (2016), Structural Equation Modeling With AMOS, Basic Concepts, Applications, and Programming, Third Edition, Routledge, Ottawa.
- Clark, A. E. (1997). Job satisfaction and gender: Why are women so happy at work? *Labour economics*, 4(4), 341-372.
- Fajana, Sola (2001). The Nigerian Informal Sector: Freeing The Hidden Potential and Raising Standards. Poster Session Paper Submitted to The Global Employment Forum, Geneva. Boro,L; Thopeson, S &Patton, C.(2001). Organizational Behaviour. London: Routledge.
- Hoppok, R., & Spielgler. (1938, April). Job Satisfaction. *Occupations: The Vocational Guidance Journal*, 16(7), 636-643. Retrieved from [on line] Available: <http://onlinelibrary.wiley.com/doi/10.1002/j.2164-1938.tb00348.x/abstract>.
- Halkos, G.M. & Bousinakis, D (2012). The influence of stress and satisfaction on productivity. Online at <http://mpr.aub.uni-muenchen.de/39654/> MPRA Paper No. 39654, UTC.
- Iverson, R.D and Deery, M. (2007). Turnover Culture in the Hospitality Industry. *Human Resource Journal*. 7(4), 71-82.
- Lambert, E.G; Pasupuleti,S; Cluse-Tolar,T and Jennings, M (2008). The Impact of Work-Family Conflict on Social Work and Human Service Worker Job Satisfaction and Organisational Commitment: An Exploratory Study. *Administration in Social Work*. 30(5) 55-74.
- Lum, L.K. (2006). Explaining Nursing Turnover Intent: Job Satisfaction or Organizational Commitment. *Journal of Organizational Behavior*. 19(6), 305-320.
- Nouri, B. & Wael, J (2011). Physical exercise / fitness: job satisfaction and work productivity (the case of Lebanon). *International Journal of Strategic Management* Publisher: International Academy of Business and Economics Audience: Academic Format: Magazine/Journal Subject: Business, international Copyright: C OPYRIGHT 2011 International Academy of Business and Economics ISSN: 1555-2411. Source Volume: 11 Source Issue: 1
- Oshagbemi, T. (2000) —Gender Differences in the Job Satisfaction of University Teachers. *Women in Management Review*. 15, 331-343.
- Perera, G, D, N (2014). Job Satisfaction and Job Performance Among Factory Employees In Apparel Sector. *Asian Journal of Management Sciences & Education*. Vol.3, No.1. pp. 96-104.
- Sekaran, U. & Bougie,R.(2011).Research methods for business: A skill building approach,5th edition, Printed in Great Britain by TJ International Ltd, Padstow, Cornwall.
- Razika, A., Maulabakhsha, R. (2014), Republic Impact of Working Environment on Job Satisfaction. ScienceDirect 2nd Global Conference on Business on economics, Management and Tourism, Prague, Czech.
- Vroom, V. (1964). *Work and Motivation*. Jhon Wiley and Sons, 91.