

Perspective of Station Uptime on Modeling and Management of the Base Station Energy Consumption

TH. SHARATCHAND MEETEI^{1*} W.C. SINGH²

1.Core Network Division, BSNL, Telephone Bhawan, Babupara, Imphal-795001, Manipur (INDIA)

2.Manipur Institute of Management Studies, Manipur University, Imphal-795004, Manipur (INDIA)

*Email of corresponding author: tsmeetei@gmail.com

Abstract

The network availability of the wireless network can be viewed as broader concept of network reliability. Reliability is a unique quality of wireless network and it is regarded as key parameter for business success of the telecom service providers. The network availability however is often compromised with outages caused by various factors and amongst the factors, inadequate energy at the base stations is the major outage-contributing factor. Due to unreliable electrical grid supply at many base stations, diesel generators are deployed to the stations as an alternative source of energy. The diesel generators incur high operating expenses. This paper presents a quantitative approach for measurement and estimation of diesel fuel consumption based on uptime hours of various equipments installed at the base station site. It also introduces a new parameter called energy conservation factor, which determines amount of energy transfer to the battery-bank while charging the battery with power from an external source such as grid, diesel generator. This model while presenting a new management perspective for effective utilization of the conserved energy of the battery-bank also attempts to reduce waste such as fuel losses and pilferages. We also describe how the method introduced in this paper can assist management in planning and preparation of fuel budget for a particular base station or the entire wireless network.

Keywords: Wireless network availability; Network reliability; Network outage; Base station site; Conserved energy; Energy conservation factor

1. Introduction

The wireless technology is one among the most sought after telecommunication technologies for daily communication and it represents an increasingly high percentage of all new telephone subscription worldwide. The network availability is the broader concept of network reliability and it is a parameter of service quality for business success in the local context of the telecom industry in Manipur. The service provider, which makes prompt address of this parameter, gets competitive advantage over other in the market that has attained oligopoly. In the present scenario, such critical parameter of business success is often compromised with outages caused by various factors such as equipment fault, transmission media fault, shutting down the base station during low traffic periods and base station power off due to diesel fuel scarcity. The problem of inadequate grid supply experienced at telecommunication installations in Manipur are being resolved by diesel generators. Electrical grid distributions to some extent and diesel generators in general are the sources of energy at the base stations in Manipur. Therefore, proper management of diesel fuel for effective utilization and achieving maximum network availability has become a challenging task to be dealt with a well thought out process, as diesel is the only reliable and dependable source of energy in the context of telecom industry in Manipur.

2. Literature review and research conceptualization

2.1 Literature review and problem definition

The dependency on wireless network for daily communication is increasing in a fastest growing rate. According to Telecom Regulatory Authority of India Report (2011-12), the wireless subscriber base in India was 919.17 million as on 31st March 2012 in comparison to the subscriber base of 811.59 million as on 31st March 2011. It added 107.58 million subscribers in the financial year 2011-12. The total subscriber base in March 2007 was 165.11 million. With the increase on dependability, there is demand for maximum network availability. Network availability is regarded as a vital feature for business success of the wireless telecom service providers. It is one of the most important measures in the reliability of the wireless network, which is the probability that the network will not malfunction or fail within a specified period. The reliability is a unique quality of wireless network that values the network and users pay premium for it. Therefore, studies on reliability issue of the wireless network at par with the wire-line have become a concern of the telecom management. The higher the availability of the wireless network the better is in reducing subscribers' churn rate from the reliability perspective.

Power supply is one of the critical challenges confronted by telecommunication operators in deploying their networks [Ani and Emetu, 2013]. The availability of the wireless network is largely depended on adequate

availability of energy at the base stations. The base station sites of many countries worldwide face the problem of unreliable electrical grid supply. For instance, Airtel Nigeria reports that non-availability of regular grid power supply to sites across the country is responsible for over seventy percent of down time, resulting in poor QoS [Ani and Emetu, 2013]. The grid power availability at base stations in India is also not sound. On average, seventy percent of the approximately 4,00,000 mobile towers in India face electrical grid outages in excess of 8 hours a day [Intelligent Energy, 2012]. In the context of Manipur, the grid power supply is experiencing an acute shortage. On average the power availability is within four to six hours a day although the Economic Survey Manipur 2010-11, Government of Manipur reported that the state had experienced a shortfall of 60 Megawatts (MW) when demand was 170 MW in the year 2009-10 indicating power outage of approximately nine hours a day. This grid power scarcity in Manipur is a common issue of all telecom service providers and in addition, the electrical grid distribution system has not reached many base station sites. The diesel generators consume relatively high amount of diesel fuel and require high level of maintenance work. As a result, diesel generators incur high operating expenses. In addition, the total monthly cash outflow is also influenced by other scenarios such as fuel losses, diesel pilferage. The fuel losses including diesel pilferage are estimated to be 15 to 20 percent of the total diesel fuel consumed [Intelligent Energy, 2012]. In order to minimize input cost of the diesel fuel, many service providers adopt different approaches. At the network level, one of the most important approaches for reducing energy consumption is dynamic management of network resources, which allows shutting down of entire base stations during a low traffic load (Josip et al., 2012). Moklesur (2009) asserts, "they also proposed to reduce the numbers of some active devices during low traffic such as nighttime and weekend day, then it is more possible to save energy" (as cited in Emerson).

2.2 Research conceptualization

There is intense competition in wireless telecom sector in Manipur since this sector is the only business area of all private telecom service providers operating in Manipur. The public sector telecom company, Bharat Sanchar Nigam Limited, BSNL is a multi-service provider which operates in Manipur with services such as wire-line, wire-line broadband internet, leased line, and wireless based telecom services. As per annual financial report 2011-12 of BSNL Manipur, seventy-three percent of the total revenue of BSNL Manipur is from its wireless services. This indicates that the survivability and sustenance of all the telecom service providers including BSNL in Manipur is depended on the wireless service sector. Sample primary data obtained from mobile switching center and base station sites of BSNL Manipur reveal that inadequate energy at the base stations is the major cause of network outage as it occupies approximately sixty percent of the total network outage hours.

In the supply chain system of diesel fuel of the network, a third party receives the fuel and runs the diesel generator. The first party is the telecom operator and the second party is another vendor to whom the responsibility of distribution of the fuel is outsourced. In BSNL, the distribution of the diesel fuel is done by its own staffs. Normally, diesel fuel loss and pilferage happen in the supply chain. The energy obtained from diesel fuel is comparatively much costlier than the energy obtained from the grid. There are considerable papers, which attempted to reduce fuel consumption at the base station sites. Some papers discussed the technical aspects including the components of the equipments and some discussed on the aspect of energy consumption based on the intensity of the traffic loading. Josip et al., (2012) asserts, "generally, it is assumed that the traffic load variations have small influence on the power consumption of base stations" (as cited in Blume et al. 2010 and Krishnamachari et al. 2011). In a typical base station site, one or more base-transceivers (BTSs) of similar or different power ratings exist. A base station site installed with four BTSs but working with only two BTSs during a time of one hour will have less energy consumption than the hour during which the site runs with all the four base-transceivers. This paper attempts to maximize the network availability of the base stations using energy conserved in the battery-bank effectively. Reengineering process can be practiced even at the bottom line level of the companies for better performance and productivity (Meetei and Singh, 2013). This work is primarily based on the process and do not go much insight into the technical aspects. In some organizations, there may be plenty of resources and technologies but due to improper utilization of the resources, they may face waiting and wasting time, which will ultimately affect the productivity (Meetei and Singh, 2013). Proper utilization of the internal resource is a way to improve productivity and hence emphasis is given to explore the potential resources, such as conserved energy of the battery bank and network outage data generated by the switching system.

In this work, we adopt linear power consumption model and presents a quantitative approach for measurement and estimation of diesel fuel consumption based on uptime hours of the base transceivers equipments, wire-line equipments and other associated equipments housed at the base station sites. This model while presenting a new perspective of management of fuel consumption with an attempt to reduce waste such as fuel losses and pilferages, it also introduces a factor called energy conservation factor. This factor is like performance indicator of the site in terms of energy and used to determine amount energy transfer to the battery while charging the

battery with an external source of power.

3. Modeling and data collection

3.1 Mathematical model for energy consumption

One or more base transceiver stations (BTSs) and other associated equipments are housed in the base station site. To ensure power availability of more than 99.95 percent, the tower owners backup the electrical grid with a combination of batteries and diesel generator. The telecom service provider or infra-service provider install diesel generators of 7.5 kVA to 63 kVA capacity and supplement it with battery banks of varying capacities. The diesel generator and battery bank configurations are decided based on the power outage pattern, equipment at the site, geographical location, optimal CAPEX (capital expenses) and OPEX (operating expenses) economics [Intelligent Energy, 2012].

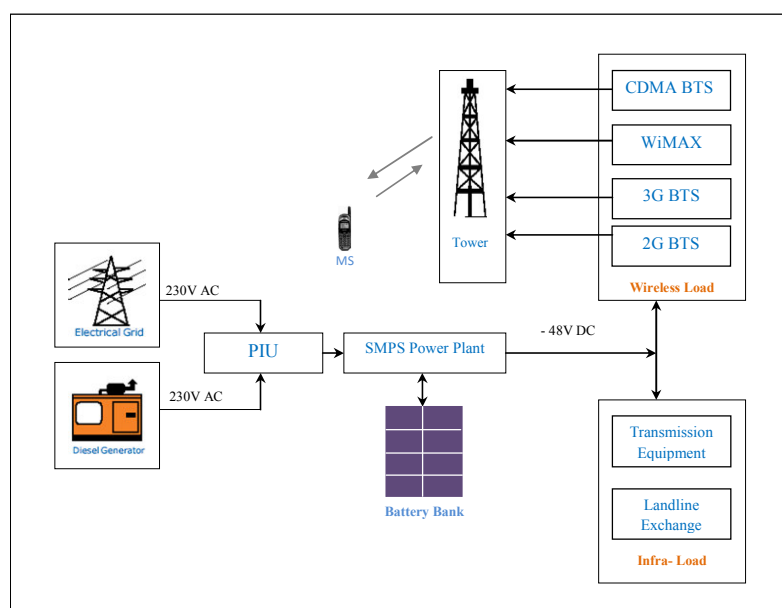

Figure 1: A typical base station site of BSNL

The Power Interface Unit (PIU) selects the best phase of the 3 phase electrical grid and provides power to the rectifier or switched mode power supply (SMPS). The SMPS converts the 220 V AC to -48 V DC providing power to the telecom tower equipment and additionally, to charge the batteries [Intelligent Energy, 2012]. If the grid power is interrupted, the batteries provide the power to the telecommunication equipment during the transition period of supply from the diesel generator. The equipments at the base stations therefore get power from three sources viz. electrical grid, battery-bank and diesel generator. A mathematical model developed for estimation of total energy consumption by the equipments at the base station sites is described below.

In this study, data obtained from base station sites of BSNL are used in designing mathematical model for energy consumption. A typical base station site of BSNL is shown in Figure 1. It consists of two or more telecom equipments, which can be grouped into two namely wireless (wireless load) and non-wireless (infra-load) based equipments. The wireless technologies deployed in BSNL network consist of base transceiver stations of (a) second generation-2G and third generation-3G GSM (Global System for Mobile Communication), (b) CDMA (Code Division Multiple Access) and (c) WiMAX (Worldwide Interoperability for Microwave Access). One or more such BTS form the wireless equipment group while the non-wireless group is represented by group of equipments such as wire-line exchange, transmission equipments and other auxiliary equipments like DC to AC converter. The power supply to both the groups is DC (-48V DC). For the convenience purpose, the DC current in Ampere drawn by the equipments in one hour is taken as power consumption and energy consumption is expressed as Ampere-Hour (AH). The unit of actual power consumption is VA (Volt-Ampere) or Watts, therefore, the actual value of the power consumption is obtained by multiplying the values of power consumption expressed in Ampere (A) by a constant DC voltage of 48V. Similarly, actual energy consumption is obtained by multiplying the values of the energy consumption expressed in Ampere-Hour (AH) by a constant DC voltage of 48V. The total power consumption of the equipments at the site is evaluated using the following

equations. It is assumed that the base transceivers and associated equipments of the site are in the ON states during the period when the station gets power either from diesel generator or from grid distribution. We have experienced that very often many BTSs are in OFF state when the BTSs are running with back-up energy from the battery bank.

Total power consumption, P_{SITE} :

$$P_{SITE} = P_{WLOAD} + P_{INFRA} \quad \dots 3.1$$

where, $P_{WLOAD} = \sum_{i=1}^m P_{2Gi} + P_{3G} + P_{CDMA} + P_{WIMAX}$
 $P_{INFRA} = \sum_{j=1}^m P_{TRANSj} + P_{BASIC}$

P_{2G} , P_{3G} , P_{CDMA} , P_{WIMAX} , P_{TRANS} , and P_{BASIC} are values of the average power consumption by the 2G BTS, 3G BTS, CDMA BTS, WiMax, Transmission equipments and Landline exchange respectively; n represents numbers of 2G BTS, m represents no. of transmission equipment. The power consumption rates of the individual equipments are the average power consumption rates obtained from the values described in the Technical Product Description of the products and actual measurements.

Backup factor, α :

$$\alpha = \frac{\sum_{k=1}^q P_{PPMK} - P_{SITE}}{P_{SITE} \times 100} \times \rho \quad \dots 3.2$$

where, P_{PPM} is power supply capacity in Amps of the individual SMPS (switched mode power supply) modules and q is the no. of SMPS modules. ρ is a energy conservation factor which has value within the range of 10 to 100, the details of which is explained in section 3.2.

Energy obtained from grid power supply, E_{ELECT} (in AH):

$$E_{ELECT} = (P_{SITE} \times t_{ELECT}) + \alpha \times P_{SITE} \times t_{ELECT} \times \beta \quad \dots 3.3$$

where, t_{ELECT} is the total hours of grid power availability. In the event of low voltage, sometimes, battery charging is not possible. In this condition value of β is 0, otherwise $\beta = 1$.

Total energy consumption, E_{SITE} (in AH):

$$E_{SITE} = P_{WIMAX} \times t_{WIMAX} + P_{3G} \times t_{3G} + \sum_i P_{2Gi} \times t_{2G} + P_{CDMA} \times t_{CDMA} + P_{INFRA} \times t_{INFRA} \quad \dots 3.4$$

where, t_{WIMAX} , t_{3G} , t_{CDMA} , t_{2G} and t_{INFRA} are total uptime hours of WiMax, 3G-BTS, CDMA-BTS, 2G-BTS and landline exchange/transmission equipment respectively. It is assumed that landline exchange is in the ON state for 24 hours and accordingly site availability is taken as 24 hours in calculation of infra energy consumption. If landline exchange does not exist at the site, then uptime availability of any wireless BTS at the time interval is treated as availability of the site in calculation of infra energy consumption.

Energy obtained from Diesel Generator, E_{DG} :

$$E_{DG} = \frac{E_{SITE} - E_{ELECT}}{1 + \alpha} \quad \dots 3.5$$

if $E_{DG} < 0$, $E_{DG} = 0$

DG run hour, t_{DG} :

$$t_{DG} = \frac{E_{DG}}{P_{SITE}} \quad \dots 3.6$$

Total diesel fuel consumption, F_{SITE} :

$$F_{SITE} = t_{DG} \times F_{DG} \quad \dots 3.7$$

where, F_{DG} is the hourly diesel fuel consumption rate (in litres) of the diesel generator obtained from the technical product specification of the diesel generator and actual measurement done at the site.

3.2 Energy conservation factor, ρ

When battery is charged under float condition through SMPS, some amount of energy is transferred from the external source say grid or diesel generator to the battery-bank and the energy is conserved there. In this model, the amount of energy transfer is determined by a factor called conservation factor, which has value between 10 to 100. The value of this factor depends on the health and capacity of the battery bank and capacity of the power plant. These values are estimated from the data obtained from experiments conducted at the sites in connection with the empirical study as illustrated below.

If F_{SITE} is the actual fuel consumption for the uptime hours of the equipments of the site, then

$$t_{DG} = \frac{F_{SITE}}{F_{DG}} \quad \dots 3.8$$

where, t_{DG} is the DG run hour and F_{DG} diesel consumption rate of the diesel generator, DG.

From equation 3.6:

$$E_{DG} = t_{DG} \times P_{SITE} \quad \dots 3.9$$

where, E_{DG} is the total energy supplied by DG and P_{SITE} is the total site power load or power consumption estimated using the equation 3.1.

From equation 3.5:

$$\alpha = \frac{E_{SITE} - E_{ELECT}}{E_{DG}} - 1 \quad \dots 3.10$$

where, E_{SITE} is the amount of total energy consumption by the equipments at the site during their respective uptime hours of the day and it is estimated using equation 3.4. E_{ELECT} is energy obtained from grid power supply source and it is estimated using equation 3.3 under condition of $\beta=0$ i.e. without charging the battery during the hours of the power availability from grid on the day of observation.

Then from equation 3.2:

$$\rho = \frac{\alpha \times P_{SITE}}{\sum_{k=1}^q P_{PPMk} - P_{SITE}} \times 100 \quad \dots 3.11$$

3.3 Outage data collection

Whenever any BTS goes to OFF state due to any reason, an event is generated in the form of either alarm or notification. The nature of reporting such events differs technology to technology. The Nortel 2G BTS, Ericsson 2G BTS, Ericsson 3G BTS, ZTE CDMA BTS and WiMax deployed in the BSNL wireless network follow different methods of event reporting system. The characteristic that is common to all is that the event report is generated by the system in the form of text file. The text file is converted to database file in this study by specific software developed for this purpose, the code of which is compiled with Clipper-5 compiler.

```

-----
## DATE:      02/05/2013  0:07:00 AM
## REPEAT:    242(for ever)
## INTERVAL:  15 minutes
-----
WO      IMP_BSC          AD-975  TIME 130502 0005  PAGE  1
<rlcrp:cell=all;
CELL RESOURCES
CELL    BCCH  CBCH  SDCCH  NOOPTCH  QUEUED
ULBV01C  0    0    0        0        0
ULBV01B  0    0    0        0        0
ULBV01A  0    0    0        0        0
MOR002C  1    1    23    28- 56    0
MOR002B  1    1    23    28- 56    0
MOR002A  1    1    23    20- 40    0
IHC001C  0    0    0        0        0
IHC001B  0    0    0        0        0
IHC001A  0    0    0        0        0
-----
## DATE:      02/05/2013  0:22:00 AM
## REPEAT:    243(for ever)
## INTERVAL:  15 minutes
-----
WO      IMP_BSC          AD-975  TIME 130502 0020  PAGE  1
<rlcrp:cell=all;
CELL RESOURCES
CELL    BCCH  CBCH  SDCCH  NOOPTCH  QUEUED
UNMG01C  0    0    0        0        0
UNMG01B  0    0    0        0        0
UNMG01A  0    0    0        0        0
    
```

Source: RLCRP log file- Ericsson BSC, BSNL Manipur
 Figure 2: Ericsson 2G BTS- Event Status Log File

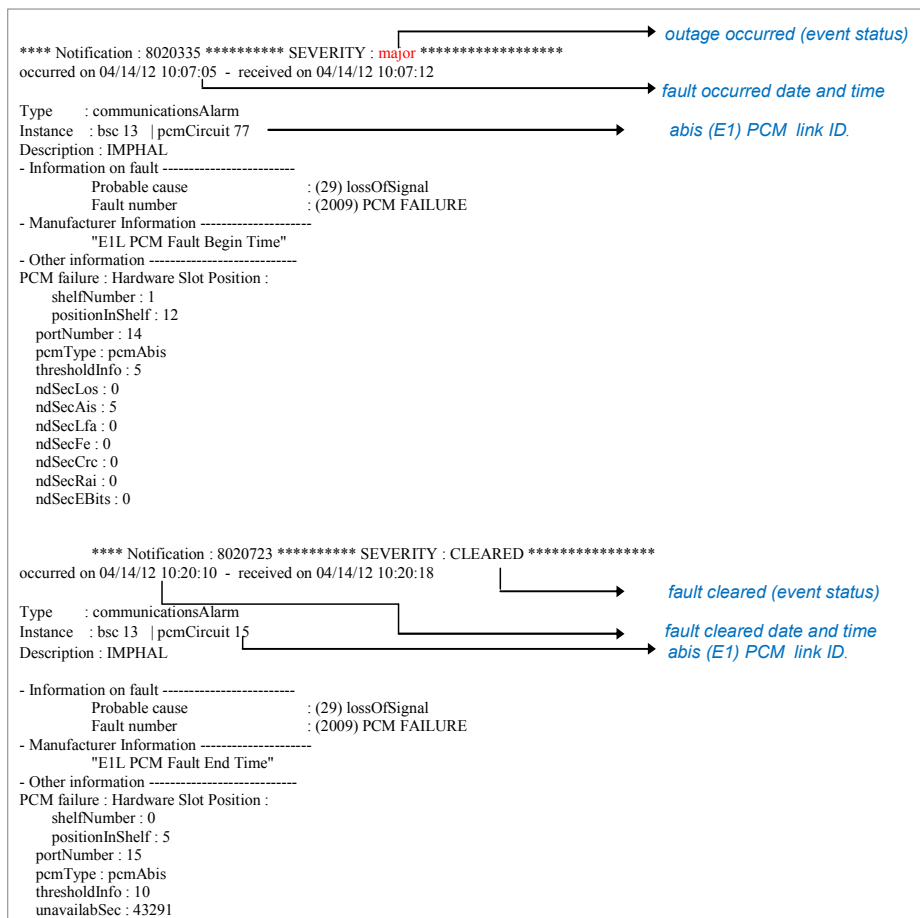

Source: Event Notification Log File - Nortel BSC, BSNL Manipur
 Figure 3: Nortel 2G BTS- Event Status Log File

In 2G Ericsson system, the status of the entire BTS parented to Base Station Controller (BSC) is checked by the system at the pre-defined specific time intervals. A time interval of 15 minutes is used in Mobile Switching Center, MSC Imphal. This means that the ON/OFF state of every BTS is checked for every 15 minutes by the switching system and the status is recorded in a system log file as an event by the system itself. In this study, the log text files are converted to database file and populated to a database called event history database. A time interval of 30 minutes is used as time gap between the events in the event history database. A small portion of outage/restore event log file of Ericsson 2G BTS is shown in Figure 2. Nortel make base transceivers follow event notification reporting system. In this system, event reports in the form of notifications are generated. If any BTS goes to OFF state or comes back to ON state, event information is generated and stored in log file. A portion of outage/restore event log file of 2G Nortel BTS is shown in Figure 3. While processing the log files the state with which the BTS had registered last is carried forward until an event of change state is occurred. This way continuity of discrete event states in the event history file is maintained. Ericsson 3G (Node B) outage/restore report is more or less similar to the report of the Nortel. However, we observe appearance of OFF state occurrence date and time along with ON state date and time whenever an event of ON state is occurred which is in addition to reporting of only OFF state event while awaiting subsequent ON state.

The ZTE make CDMA BTS event report looks like the report of 3G BTS of Ericsson, however, the difference is that in this system an event is reported only when there is occurrence of ON state event. While reporting the ON state event occurrence time of a BTS, the system also reports the time when the BTS went to OFF state just before the present ON state. Therefore, if a BTS goes to OFF state and continue to remain in that state then the OFF state does not appear in the log files generated during the period in which the BTS remains in OFF state. In order to avoid carry forward of ON state to the event history database based on the last registered ON state, the status of the BTS is interrogated at exchange terminal at least once in day to obtain latest status of the BTS. The latest status of the OFF state of the BTS is updated manually to the event history database. The time gap between the actual time of OFF event and manual time of the OFF event is reconciled by the processing software once the

status of the BTS changes to ON state. In this way, the event states of all the BTS of the base station sites are processed and populated to the event history database.

3.4 Estimation of conservation factor

It is based on empirical study and for this purpose experiments at select base station sites were conducted under $\beta=0$ condition of the equation 3.3. The procedure of the experiment that is how the energy conservation factors of the sites are estimated is described below.

While running the site with power supply from diesel generator, the battery (battery bank) is kept on float through SMPS until the battery is fully charged. All the base transceivers housed at the site are turned-on during this period. The power supply from DG is then withdrawn soon after the battery is charged fully. However, the base transceivers remain active as the site gets power supply from the conserved energy. One or two BTS of the site are turned-off for some time and then turned-on while site is running with the power supply from battery. This process is continued until we cover all the 24 hours of the day and repeat the process for another 5 to 7 days. Thus, the experimental values of actual diesel fuel consumption (F_{SITE}) and actual run hours of the DG are obtained. These fuel consumption and run hours data are then used to calculate the fuel consumption rate (F_{DG}) of the diesel generator. The uptime of the individual base transceivers is available in the event history database, this is in addition to the uptime data recorded at the site during experiment.

Equipment Code	Power Consumption in Amp	Name of Equipment	Equipment Code	Power Consumption in Amp	Name of Equipment
ADM01	4.00	TR EQU 1 NO	OCL01	6.00	OCLAN 1 NO
ADM02	8.00	TR EQU 2 NO	OCL02	12.00	OCLAN 2 NO
ANR01	10.00	ANRAX 1 NO	PMU01	4.00	PRIMARY MUX 1N
ANR02	20.00	ANRAX 2 NO	RM001	3.00	RM TRANS EQUIP
CPE01	1.00	CPE 1 NO	RM002	6.00	RM TRANS EQUIP
CPE02	2.00	CPE 2 NO	RSU01	14.00	RSU 1K
DG007	1.1 Litres	DG 7.5KVA	RSU02	28.00	RSU 2K
DG012	1.5 Litres	DG 12.5 KVA	RSU03	42.00	RSU 3K
DG015	2 Litres	DG 15KVA	RSU06	84.00	RSU 6K
DG020	2.2 Litres	DG 20KVA	STM1	6.00	STM1 EQUIP
DG030	2.75 Litre	DG 30KVA	TM101	6.00	STM1 1NO
DG040	4.2 Litres	DG 40KVA	TM102	12.00	STM1 2NO
DG050	4.5 Litres	DG 50 KVA	TM161	6.00	STM16 1NO
DG063	7 Litres	DG 63 KVA	TM162	12.00	STM16 2NO
DG100	9.5 Litres	DG 100 KVA	TM401	6.00	STM4 1NO
DSL01	6.00	DSLAM 1 NO	VMU01	4.00	VMUX 1NO
DSL02	12.00	DSLAM 2 NO	VMU02	8.00	VMUX 2NO
DWDM1	5.00	DWDM 1 NO	VMU03	12.00	VMUX 3NO
ERI2G	25.00	ERIC 2G BTS	VSA01	1.50	VSAT 1 NO.
ERI3G	15.00	ERIC 3G BTS	VSA02	3.00	VSAT 2 NO.
MADM1	6.00	MADM 1 NO	VSA03	4.50	VSAT 3 NO.
MBM01	40.00	MBM EXCH	WIPH1	5.00	WIMAX PHASE-I
ML001	2.00	MINI LINK-1 NO	WIPH2	5.00	ZTE WIMAX PH-II
ML002	4.00	MINI LINK-2 NO	WL1FA	25.00	WLL BTS 1FAA
ML003	6.00	MINI LINK-3 NO	WL1FE	25.00	WLL BTS 1FAE
ML004	8.00	MINI LINK-4 NO	WLEV0	5.00	WLL EVDO
MUX01	4.00	MUX EQUIP	WLEV1	30.00	EVDO BTS+01FAE
NOR2G	25.00	NORTEL 2G BTS	WLMBT	6.00	WLL MICRO BTS

Source: Compiled based on product specification and measurement
 Table 1: Power Consumption

Date	Site Name	Energy (AH)		Diesel fuel consumption in Ltrs (PSITE)	DG Diesel consumption per Hr(FDG)	DG run Hour (tDG)	Site load in Amp (PSITE)	Energy from DG in AH (EDG)	Value of α	No. of BTS	Elect Grid Supply Hour	PP Capacity (Amp), (PPM)	Value of ρ	Site availability hours	Site down hours	2G BTS availability Hours	3G BTS availability hours
		From DG+Bty (ESITE)	From Grid (FELECT)														
20/05/2013	AYANGPALLI	581	0	11.5	2	5.75	44	253	1.3	2	0	150	54	24	0	5	24
21/05/2013	AYANGPALLI	606	0	11.8	2	5.9	44	259.6	1.33	2	0	150	55	24	0	6	24
22/05/2013	AYANGPALLI	581	0	11.4	2	5.7	44	250.8	1.32	2	0	150	55	24	0	5	24
23/05/2013	AYANGPALLI	606	0	11.7	2	5.85	44	257.4	1.35	2	0	150	56	24	0	6	24
24/05/2013	AYANGPALLI	656	0	12.8	2	6.4	44	281.6	1.33	2	0	150	55	24	0	8	24
19/05/2013	KAKWA	643.5	0	11.4	2	5.69	44	250.27	1.57	2	0	150	65	24	0	7.5	24
20/05/2013	KAKWA	581	0	10.3	2	5.15	44	226.6	1.56	2	0	150	65	24	0	5	24
21/05/2013	KAKWA	693.5	0	12.1	2	6.07	44	266.96	1.6	2	0	150	66	24	0	9.5	24
22/05/2013	KAKWA	593.5	0	10.4	2	5.21	44	229.42	1.59	2	0	150	66	24	0	5.5	24
23/05/2013	KAKWA	605.5	0	10.6	2	5.31	44	233.59	1.59	2	0	150	66	14.5	9.5	13.5	14
24/05/2013	KAKWA	273.5	0	4.7	2	2.37	44	104.28	1.62	2	0	150	67	6.5	17.5	6	6.5
20/05/2013	KSHETRIGAO-II	606	0	12.5	2	6.25	44	275	1.2	2	0	150	50	24	0	6	24
21/05/2013	KSHETRIGAO-II	581	0	12	2	6	44	264	1.2	2	0	150	50	24	0	5	24
22/05/2013	KSHETRIGAO-II	631	0	13.1	2	6.55	44	288.2	1.19	2	0	150	49	24	0	7	24
23/05/2013	KSHETRIGAO-II	656	0	13.5	2	6.75	44	297	1.21	2	0	150	50	24	0	8	24
24/05/2013	KSHETRIGAO-II	606	0	12.5	2	6.25	44	275	1.2	2	0	150	50	24	0	6	24
20/05/2013	LAMPHELPAT	581	0	10	1.6	6.25	44	275	1.11	2	0	100	87	24	0	5	24
21/05/2013	LAMPHELPAT	606	0	10.5	1.6	6.56	44	288.75	1.1	2	0	100	86	24	0	6	24
22/05/2013	LAMPHELPAT	618.5	0	10.7	1.6	6.69	44	294.25	1.1	2	0	100	87	24	0	6.5	24
23/05/2013	LAMPHELPAT	593.5	0	10.3	1.6	6.44	44	283.25	1.1	2	0	100	86	24	0	5.5	24
24/05/2013	LAMPHELPAT	606	0	10.5	1.6	6.56	44	288.75	1.1	2	0	100	86	24	0	6	24
25/05/2013	BRAHMAPUR	711	220	10.8	2	5.4	44	237.6	1.99	2	4	200	56	24	0	19	24
26/05/2013	BRAHMAPUR	711	220	10.8	2	5.4	44	237.6	1.99	2	4	200	56	24	0	19	24
27/05/2013	BRAHMAPUR	611	220	9.2	2	4.6	44	202.4	2.02	2	4	200	57	24	0	15	24
28/05/2013	BRAHMAPUR	698.5	220	10.6	2	5.3	44	233.2	2	2	4	200	56	24	0	18.5	24
29/05/2013	BRAHMAPUR	661	220	10	2	5	44	220	2	2	4	200	57	24	0	17	24
30/05/2013	BRAHMAPUR	456.5	220	6.9	2	3.45	44	151.8	2.01	2	4	200	57	16	8	15.5	15
25/05/2013	KHURAI	605	176	11.7	2	5.85	44	257.4	1.35	2	4	150	56	24	0	13	24
26/05/2013	KHURAI	542.5	176	10.5	2	5.25	44	231	1.35	2	4	150	56	24	0	10.5	24
27/05/2013	KHURAI	605	176	11.7	2	5.85	44	257.4	1.35	2	4	150	56	24	0	13	24
28/05/2013	KHURAI	580	176	11.3	2	5.64	44	248.29	1.34	2	4	150	55	24	0	12	24
29/05/2013	KHURAI	592.5	176	11.5	2	5.75	44	252.89	1.34	2	4	150	56	24	0	12.5	24
25/05/2013	KOIRENGEI CMC	188.5	232	4.9	2	2.45	29	71.05	1.65	1	4	100	68	14.5	9.5	14.5	0
26/05/2013	KOIRENGEI CMC	203	232	5.2	2	2.58	29	74.79	1.71	1	4	100	70	15	9	15	0
27/05/2013	KOIRENGEI CMC	203	232	5.2	2	2.58	29	74.79	1.71	1	4	100	70	15	9	15	0
28/05/2013	KOIRENGEI CMC	188.5	232	4.9	2	2.45	29	71.05	1.65	1	4	100	68	14.5	9.5	14.5	0
29/05/2013	KOIRENGEI CMC	145	232	4.1	2	2.06	29	59.83	1.42	1	4	100	58	13	11	13	0
30/05/2013	KOIRENGEI CMC	377	232	9.1	2	4.55	29	131.95	1.86	1	4	100	76	21	3	21	0
31/05/2013	KOIRENGEI CMC	217.5	232	5.5	2	2.77	29	80.39	1.71	1	4	100	70	15.5	8.5	15.5	0
20/05/2013	KSHETRIGAO-I	655	176	21	2	10.5	44	462	0.42	2	4	150	17	24	0	15	24
21/05/2013	KSHETRIGAO-I	667.5	176	21.4	2	10.7	44	470.8	0.42	2	4	150	17	24	0	15.5	24
22/05/2013	KSHETRIGAO-I	680	176	21.8	2	10.9	44	479.6	0.42	2	4	150	17	24	0	16	24
23/05/2013	KSHETRIGAO-I	680	176	21.4	2	10.7	44	470.8	0.44	2	4	150	18	24	0	16	24
24/05/2013	KSHETRIGAO-I	630	176	20.2	2	10.1	44	444.4	0.42	2	4	150	17	24	0	14	24
25/05/2013	KHONGMAN	379.5	514	10.5	2.2	4.76	44	209.58	0.81	2	4	100	64	24	0	17.5	24
26/05/2013	KHONGMAN	367	514	10.5	2.2	4.76	44	209.58	0.75	2	4	100	59	24	0	17	24
27/05/2013	KHONGMAN	367	514	10.5	2.2	4.76	44	209.58	0.75	2	4	100	59	24	0	17	24
28/05/2013	KHONGMAN	367	514	10.5	2.2	4.76	44	209.58	0.75	2	4	100	59	24	0	17	24
29/05/2013	KHONGMAN	342	514	10	2.2	4.55	44	200.19	0.71	2	4	100	56	24	0	16	24
30/05/2013	KHONGMAN	354.5	514	10.3	2.2	4.69	44	206.45	0.72	2	4	100	56	24	0	16.5	24
31/05/2013	KHONGMAN	379.5	514	10.9	2.2	4.94	44	217.4	0.75	2	4	100	59	24	0	17.5	24

Table 2: Experimental values of energy conservation factors of some sites

Site Name	Mean Value of Conservation Factor	Std Deviation	Observation Days	Std Error	Degrees of Freedom	t Value	Upper Confidence Limit	Lower Confidence Limit
Ayangpalli	55	0.707	5	0.316	4	2.776	55.88	54.12
Kakwa	65.8	0.837	5	0.837	4	2.776	66.84	64.76
Kshetrigao-II	49.8	0.447	5	0.2	4	2.776	50.36	49.24
Lamphelpat	86.5	0.548	6	0.22	5	2.571	87.07	85.93
Brahmapur	56.5	0.548	6	0.22	5	2.571	57.07	55.93
Khurai	55.8	0.447	5	0.2	4	2.776	56.36	55.24
Koirengei CMC	71.33	3.72	6	1.52	5	2.571	75.24	67.42
Kshetrigao-I	17.2	0.447	5	0.2	4	2.776	17.76	16.64
Khongman	58	1.6	6	0.653	5	2.571	59.67	56.32

Table 3: Interval estimates (t Distribution) of the conservation factors

Table 1 is the list of equipments normally found at base station sites; one or more such equipments are available at the base station sites. Then, the values of P_{SITE} , E_{ELECT} and E_{SITE} are computed with the help of the table 1 and uptime hours of the individual BTS of the site. Using equation 3.9, 3.10 and 3.10, the values of energy conservation factors of the sites are then estimated.

Table 2 shows the energy conservation factors of some sites, which have been estimated based on the data obtained from the experiments conducted at the respective base station sites. The experimental values of energy conservation factors, ρ shown in Table 2 are gathered as samples and then interval estimates for these conservation factors are computed using t-Distribution with 95 percent confidence. Table 3 shows the confidence level limits of the t-Distribution of sites shown in Table 2. In this study, the lower confidence limits of the energy conservation factors are taken as values of energy conservation factors, ρ of the respective sites.

4. Measurement of energy consumption

4.1 Real uptime and energy consumption

This section demonstrates the steps to be followed in calculation of total energy consumption based on the real live uptime of the base stations. The input data viz. (1) the energy conservation

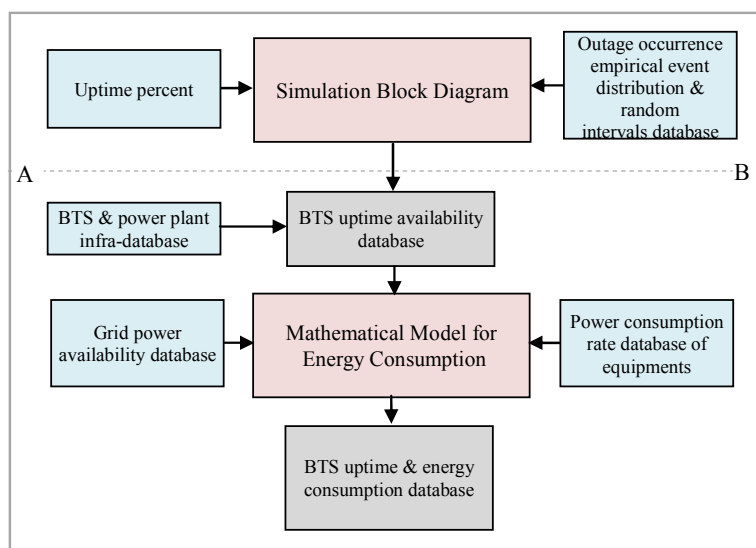

Figure 4: Block diagram for measurement of energy consumption

factors of the base stations recorded in infra-database, (2) uptime data available in event history database and (3) power consumption rate of the equipments are the main sources of input in calculation of the total fuel consumption. The portion below the line AB in Figure 4 represents schematic block diagram for calculation of

diesel fuel consumption of the base stations. In order to calculate the amount of diesel fuel consumption, this study uses a computer program, which has been developed based on the mathematical model for energy consumption discussed in section 3.1. The energy consumption in terms of quantity of diesel fuel consumption in litres is finally stored in the energy consumption database. The quantity of the fuel consumption is in fact a theoretical value, however, under the normal conditions of site infra such as battery, DG, SMPS and base-transceivers, we do not expect much difference between the theoretical and actual values as the site-infra have been fine-tuned during the experiments conducted for estimation of conservation factors. If we observe abnormal difference under normal condition of site infra, say for example, actual quantity of diesel fuel consumption is much higher than the theoretical value; then from the management point of view, we could justifiably say that the difference can be because of running the DG even after the battery is fully charged and/or fuel pilferage.

4.2 Simulation of uptime hours and fuel budget estimation

Under the given infrastructures, conservation factors and uptime hours of the BTSs, we can calculate the diesel fuel requirements of the base station sites. Now, if we suppose that we have live uptime data of BTSs, which is within 40 to 70 percent but we are interested to know diesel fuel requirement for the network uptime of 80%, 85%, 95% or even 100%. In this case, we can go for simulation. Figure 4 shows the block schematic of the simulation process for generation of uptime hours and estimation of diesel fuel consumption. The simulation software developed for this purpose can generate random numbers and based on these random numbers the time slots of the day during which the BTSs are to be brought to the ON state can be obtained from the outage occurrence probability distribution. The uptime percent is the percentage upto which the network is to be brought to the ON state. The simulation process can estimate the quantity of diesel fuel consumptions of the network for different uptime hours of the network.

5. Conclusion

In this paper, we provide network availability of the wireless network as a function of diesel fuel. We have introduced an approach to maximize network availability of the wireless network based on effective utilization diesel fuel. This work is more process oriented than the technical aspect however, from the perspective management we try to save diesel fuel by giving emphasis on the energy conserved in the battery. The energy conservation factor introduced in this paper is an energy performance indicator. The battery-bank, SMPS modules and diesel generator of the site are collectively responsible for better conservation factor. The higher in the conservation factor is better in conserved energy. The event report is a good aspect in computing theoretical value of fuel consumption and comparison of it with the actual quantity fuel consumption can draw certain inferences on health of the power plant, battery, diesel generator and fuel pilferage. Based on the inferences management could initiate necessary steps for better monitoring and control of the routine operation and supply chain. Uptime simulation will help management in estimation of diesel fuel requirement for a particular base station or the entire wireless network and it can be used in preparation of fuel budget. Thus, effective monitoring and control based on the model discussed in this paper will help management minimize fuel expenses and maximize network availability.

References

- [1] Ani, V. Anayochukwu., & Emetu, A. Nnene. (2013 April 30). Simulation and Optimization of Hybrid Diesel Power Generation System for GSM Base Site in Nigeria. *Electronic Journal of Energy & Environment*, 1(1), 37-56.
- [2] Ani, V. Anayochukwu., & Emetu, A. Nnene. (2013 April 30). Measuring the Environmental Impact of Power Generation at GSM Base Station Sites. *Electronic Journal of Energy & Environment*, 1(1), 71-79.
- [3] Cellular Operator Association of India. (2013). *GSM System and Cellular Architecture*. New-Delhi: Author. Retrieved from <http://www.coai.com/technology.php>
- [4] Directorate of Economics & Statistics, Government of Manipur. (2011). *Economic Survey Manipur 2010-11*. Imphal: Author.
- [5] Ericsson Radio Systems AB. (1998). *GSM System Survey, Student Text EN/LZT 1233321 R3B*. Stockholm, Sweden: Author
- [6] Ericsson AB. (2005). *RBS 29x4- Product Description*. Stockholm, Sweden: Author
- [7] Faruk, Nasir., Mujahid, Y.C., Olayiwola, W.B., Abubakar, A., John, A., & Gumel, I. Md. (2012). Energy Conservation through Site Optimization for Mobile Cellular Systems (Base Transceivers Station Optimization). *Epistemics in Science, Engineering and Technology*, 2(1), 26-33.
- [8] Flood, J.E. (2011). *Telecommunication Switching, Traffic and Networks*. New-Delhi: Pearson Education.
- [9] Freescale Semiconductor. (2009). *Wireless Base Station Evolution: 2G and 3G Colocation Solution For LTE Access*. East Kilbride, Scotland: Author.

- [10] Gerald, V. Post., & David, L. Anderson. (1998). *Management Information Systems: Solving Business Problems with Information Technology*. New Delhi: Tata McGraw-Hill.
- [11] Intelligent Energy. (2012 August). *The True Cost of Providing Energy to Telecom Towers in India*. White Paper.
- [12] Joseph, D. Booth., Greg, Lief., & Craig, Yellick. (1993). *Clipper-5, A Developer's Guide*. New-Delhi: BPB Publications.
- [13] Josip, Lorincz., Tonko, Garma., & Goran, Petrovic. (2012 March 28). Measurements and Modeling of Base Station Power Consumption under Real Traffic Loads. *Sensors*, 12, 4282-4310.
- [14] Meetei, Th. Sharatchand., & Singh, W.C. (2013, Sept 1). The practice of Business Process Re-engineering at bottom-line and its impact on Productivity: An experimental study of BSNL. *The International Journal's Research Journal of Science & IT Management*, 2(11), 35-46.
- [15] Mokulesur, R. Md. (2009). *Overview of energy saving aspects in 2G and 3G Mobile Communication Networks* (Master's Thesis, University of Gavle, Stockholm, Sweden).
- [16] Michael, Hammer., & James, Champy. (2001). *Reengineering the Corporation, A Manifesto for Business Revolution*. London: Nicolas Brealey Publishing.
- [17] Preeti, Rastogi. (2005). *Assessing Wireless Network Dependability Using Neural Networks* (Master's thesis, Ohio University, USA).
- [18] Telecom Regulatory Authority of India. (2012). *Telecom Sector in India: A Decadal Profile*. New-Delhi: Author.
- [19] Telecom Regulatory Authority of India. (2012). *Annual Report 2011-12*. New-Delhi: Author.
- [20] Theodore, S. Rapport. (2012). *Wireless Communications, Principles and Practice, 2nd Edition*. New Delhi: Pearson Education.