



## Shear capacity of post-installed anchors according to ACI318 and TS500

Özlem Çalışkan<sup>a,\*</sup>, Salih Yılmaz<sup>b</sup>, Hasan Kaplan<sup>c</sup>

<sup>a</sup> Department of Civil Engineering, Bilecik Şeyh Edebali University, 11210 Bilecik, Turkey

<sup>b</sup> Department of Civil Engineering, İzmir Katip Çelebi University, 35620 Izmir, Turkey

<sup>c</sup> Department of Civil Engineering, Pamukkale University, 20070 Denizli, Turkey

### ABSTRACT

Applications of strengthening works have accelerated gradually due to earthquakes in recent years. Different strengthening methods are being used in order to bring the structures with insufficient strength to those levels specified by current codes. In most of the applications, the bonding between the new structural elements and the concrete of the old structure is established with the chemical anchors. Although they are used widespread in the practice, there are not any sufficient details in Turkish Standards for the design and application of these anchors. In this work, a comparison of ACI318 and the Turkish Standards for anchor shear strength is given. As the result, it has been concluded that there are vital differences between ACI and the Turkish Standards and that an immediate revision is needed for the Turkish Standards.

### ARTICLE INFO

*Article history:*

Received 3 March 2016

Accepted 28 April 2016

*Keywords:*

Post-installed anchors

Shear capacity;

TS500

ACI318

Edge distance

### 1. Introduction

Anchors are used to maintain integrity of structural elements that are separately constructed. They are frequently used for connections especially between reinforced concrete – steel and reinforced concrete – reinforced concrete. Due to increase in the number of strengthening applications of structures in recent years, there is also a considerable increase the use of post-installed anchors (Yılmaz and Kaplan, 2009). In these applications both chemical and mechanical usages of anchor are possible, whereas chemical anchors are mostly preferred, as they are more economical. Depending on their direction and locations, these anchors may resist shear or tension forces, or both of them.

In the literature, there exist many studies about anchors. In most of them, the tensile capacity of anchors are studied. On the other hand, the concrete elements used in those had a compressive strength greater than 30 MPa in most cases (Cook et al., 1992; McVay et al., 1996; Primavera et al., 1997; Fujikake et al., 2003; Zamora et al., 2003). The experiments with a concrete compressive strength lower than 20 MPa are a minor part of all the literature (Özkul et al., 2001; Eligehausen et al., 2006; Gürbüz, 2007; Kaya, 2007). Although tensile strength of

anchors are well-studied, research on shear strength of anchors are limited in number (Fuchs et al., 1999; Muratli et al., 2004; Özturan et al., 2004). The effects of edge distance and the spacing on the shear strength are researched and it was observed that the shear strength is proportional with the edge distance. ACI Committee 349 shear strength formula presents the estimated acceptable lower limit for the test results of the work by Ueda et al. (1990). The researchers, who evaluated the data base for anchor experiments, which is compiled by ACI Comitee 349 and 355, have observed that the concrete edge distance in the direction of loading has a significant effect on the shear strength of anchors. They have also observed that the embedment depth and diameter have a minor effect on the shear strength of anchor and that there is not any linear relationship between the shear capacity of anchor and the compressive strength of concrete. (Alqedra and Ashour, 2005).

In literature, various methods were presented to determine the anchor shear capacity. However, in the recent years, common approach is to find the capacities for different failure modes separately and to take the lowest strength as the anchor shear capacity into consideration. In parallel with that approach, an important revision was made after the 2002 version of ACI318 (2008) and the

\* Corresponding author. Tel.: +90-228-2141561 ; Fax: +90-228-2141222 ; E-mail address: ozlem.caliskan@bilecik.edu.tr (Ö. Çalışkan)

calculation methods for anchor tensile and shear capacities were changed. On the other hand, even though there isn't any regulation in TS500 about the anchors, which are post-installed in to the concrete, a separate section about strengthening of structures was added to Turkish Earthquake Code in 2007. In this section, it was referred to formula of shear friction, which is given in TS500 (2000) for the shear capacity of anchor elements. In this formula, which was not changed since the version of TS500 in 1984, only the capacity that corresponds to steel failure is taken into consideration. Weaker failure modes caused by the failures in concrete are neglected. However, the compressive strength of concrete in strengthened structures in Turkey is extremely low and the anchor workmanship is not sufficient in quality. Two extreme cases in Fig. 1 clearly shows the possible lower limits of anchor quality.



**Fig. 1.** Concrete quality and anchor workmanship in some strengthened structures.

In this study, anchor strengths were calculated for different embedment depth, base concrete strength according to ACI318 and TS500 standards. Both standards are compared and some revisions are proposed for TS500.

## 2. Material and Method

### 2.1. ACI318 method

ACI318 identifies three different failure modes for the ultimate case, when anchor shear capacity is reached: Steel failure, concrete breakout and concrete pryout.

These failure modes are illustrated in Fig. 2. Generally it can be expressed that in cases where the anchor bar is near to free edge, the breakout and pryout capacities are governing the anchor capacity, and in cases where this distance is far, failure of the anchor bar is determining the ultimate strength.

With consideration of the failure of steel, the anchor strength can be calculated by Eq. (1).

$$V_{sa} = n * A_{se} * f_{uta} \quad (1)$$

Here,  $n$  represents the number of anchors in the group,  $A_{se}$  represents the sectional area of the anchor ( $\text{mm}^2$ ) and  $f_{uta}$  represents the tension strength of steel ( $\text{N}/\text{mm}^2$ ).

When the failure is at concrete breakout mode, the breakout capacity can be found by Eq. (2) for single anchor, and in Eq. (3) for group anchors.

$$V_b = 0,6 \left( \frac{l_e}{d_o} \right)^{0,2} \sqrt{d_o} \sqrt{f'_c} n (c_{a1})^{1,5}, \quad (2)$$

$$V_b = 0,7 \left( \frac{l_e}{d_o} \right)^{0,2} \sqrt{d_o} \sqrt{f'_c} n (c_{a1})^{1,5}. \quad (3)$$

Here,  $l_e$  load bearing length of anchor for shear,  $f'_c$  specified compressive strength of concrete,  $d_o$  outside diameter of anchor.

For pryout failure, the formula given by ACI318 is shown for a single anchor in Eq. (4) and for group anchors in Eq. (5). Pryout capacity can be calculated depending on the axial breakout capacity.

$$V_{cp} = k_{cp} * N_{cp}, \quad (\text{for a single anchor}) \quad (4)$$

$$V_{cpg} = k_{cp} * N_{cpg}. \quad (\text{for a group of anchors}) \quad (5)$$

Here,  $N_{cb}$  nominal concrete breakout strength in tension of a single anchor,  $N_{cbg}$  nominal concrete breakout strength in tension of a group of anchors,  $k_{cp}$  is a coefficient depending on the embedment depth,  $k_{cp}=1.0$  for  $h_{ef} < 65$  mm ;  $k_{cp}=2.0$  for  $h_{ef} \geq 65$  mm.

The capacity is calculated for three different failure modes separately according to ACI318, and the failure mode with the lowest strength is determining the ultimate shear capacity. It is important to note that these forces corresponds to capacity estimations. For design forces ACI introduces capacity reduction factors also.

### 2.2. TS500 method

Turkish Earthquake Code references TS500 sliding shear formula for calculation of the anchor shear capacity. According to sliding shear formula in TS500, only the failure mode of reinforcement is taken into consideration. TS500 formula is given in the Eq. (6).

$$V_r = \mu * A_s * f_{yd}, \quad (6)$$

$\mu$  value is a constant depending on roughness of the surface,  $A_s$  is the reinforcement area ( $\text{mm}^2$ ), and  $f_{yd}$  is the design yield strength of reinforcement ( $\text{N}/\text{mm}^2$ ).

The lowest possible value of the friction coefficient is given as 0.6. Therefore, in this study,  $\mu=0.6$  is used, in order to determine anchor capacities according to TS500.

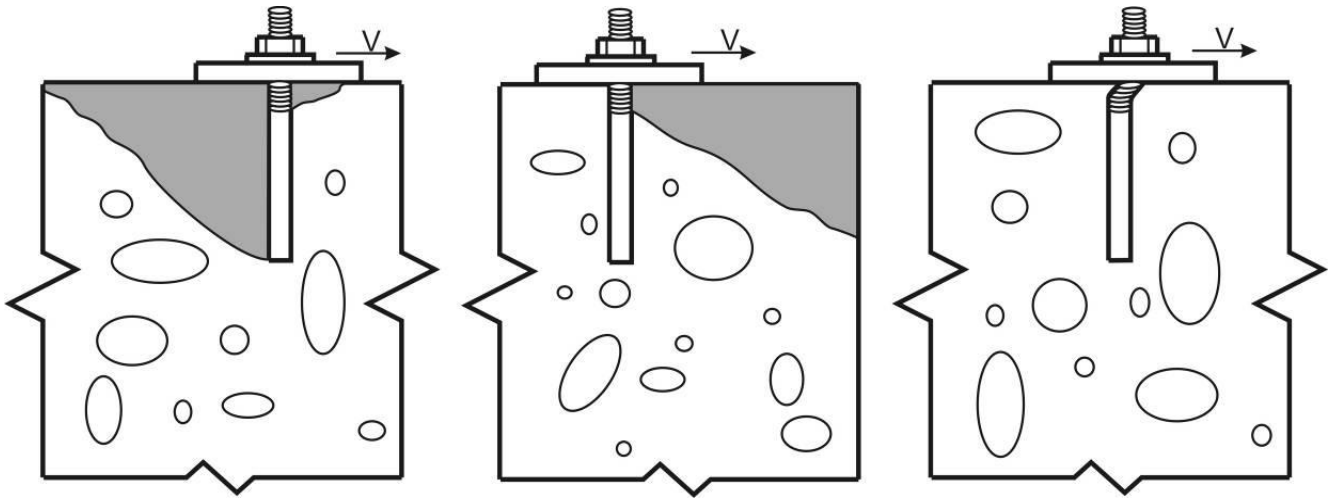

Fig. 2. Anchor failure modes.

### 3. Parameters

Embedment depth, base concrete strength, free edge distance and bar diameter are variable parameters. In

the scope of the study, the shear capacities of anchors between 12 mm to 24 mm bar sizes are determined per ACI318 and TS500. The parameters used in the study are shown in Table 1.

Table 1. Parameters used in the work.

Depth <i>L</i>	Concrete Compression Strength <i>C</i> (MPa)	Edge distance <i>c</i> (mm)	Bar diameter <i>d</i> (mm)
10Φ	8	50	12
15Φ	12	100	14
20Φ	20	150	16
		200	18
			20
			22
			24

### 4. Shear Capacity of Anchors

Shear capacities of anchors with different diameter, embedment depth and edge distance, which are calculated according to TS500 and ACI318, are compared in Fig. 3 for base concrete strengths of 8, 12 and 16 MPa. Each point on the curves corresponds to a different bar size. Bar diameters from down to up are 12, 14, 16, 18, 20, 22 and 24 mm, respectively.

For anchors with edge distance equal to 100 mm and less, the TS500 values are greater than those calculated by ACI318 method in concretes with 8 MPa compressive strength. Evaluation of anchors designed per TS500 for 12 MPa concrete, all anchors with edge distance less than 50 mm are unsafe according to ACI318. While the edge distance increases to 100 mm, anchors with smaller diameters, i.e. 16 mm and smaller, can be safely designed by TS500. However, the problem is the same for greater bar sizes. For C16 concrete class, TS500 design forces for edge distance equal to 50 mm are not safe according to capacity determined per ACI318. Greater edge distances results

in safer design loads. Accordingly, the decrease in concrete strength and the increase in reinforcement diameter are negatively affecting the reliability of the TS500 formula.

In Fig. 4, the ACI318 and TS500 design forces for anchors are given for varying edge distances. These graphics are given for three different embedment depths (10Φ, 15Φ ve 20Φ) and for three different reinforcement diameters (12, 16 and 20 mm). Edge distance directly affect the capacity of anchor according to ACI318 formulation, However, TS500 formulation results in the same capacity for different edge distances. If the edge distance is great enough, which corresponds to minority of actual cases in practice, then TS500 gives safe results. For example, for an anchor bar with 10Φ embedment depth, the TS500 formula is on the safe side with respect to ACI318, when the edge distance is greater than 100 mm for 12mm bars installed in to C8 block. This lower limit, which defines reliability of TS500 formula, increases to 150 mm for Φ20 mm bars.

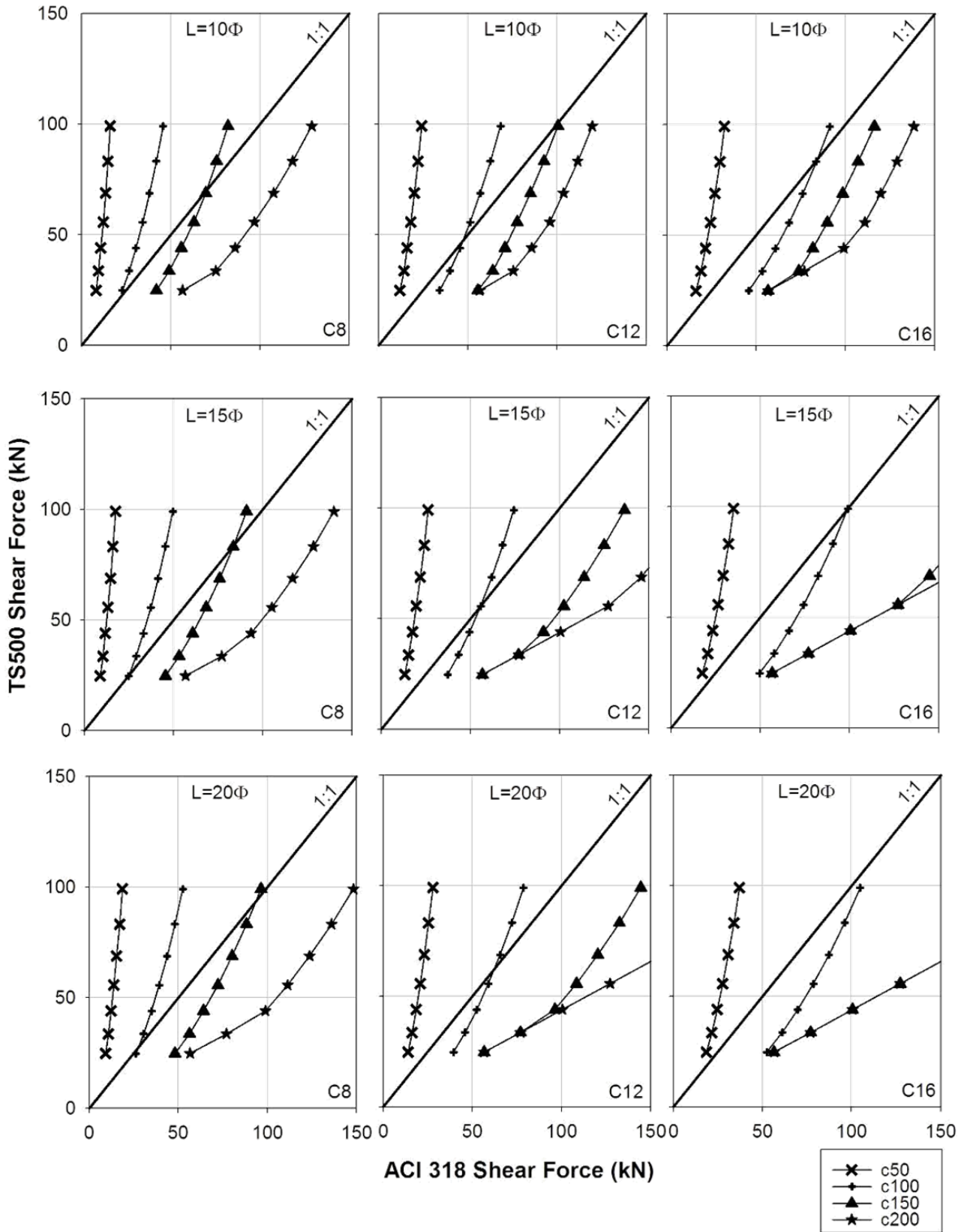

Fig. 3. ACI318 - TS500 comparison of shear forces.

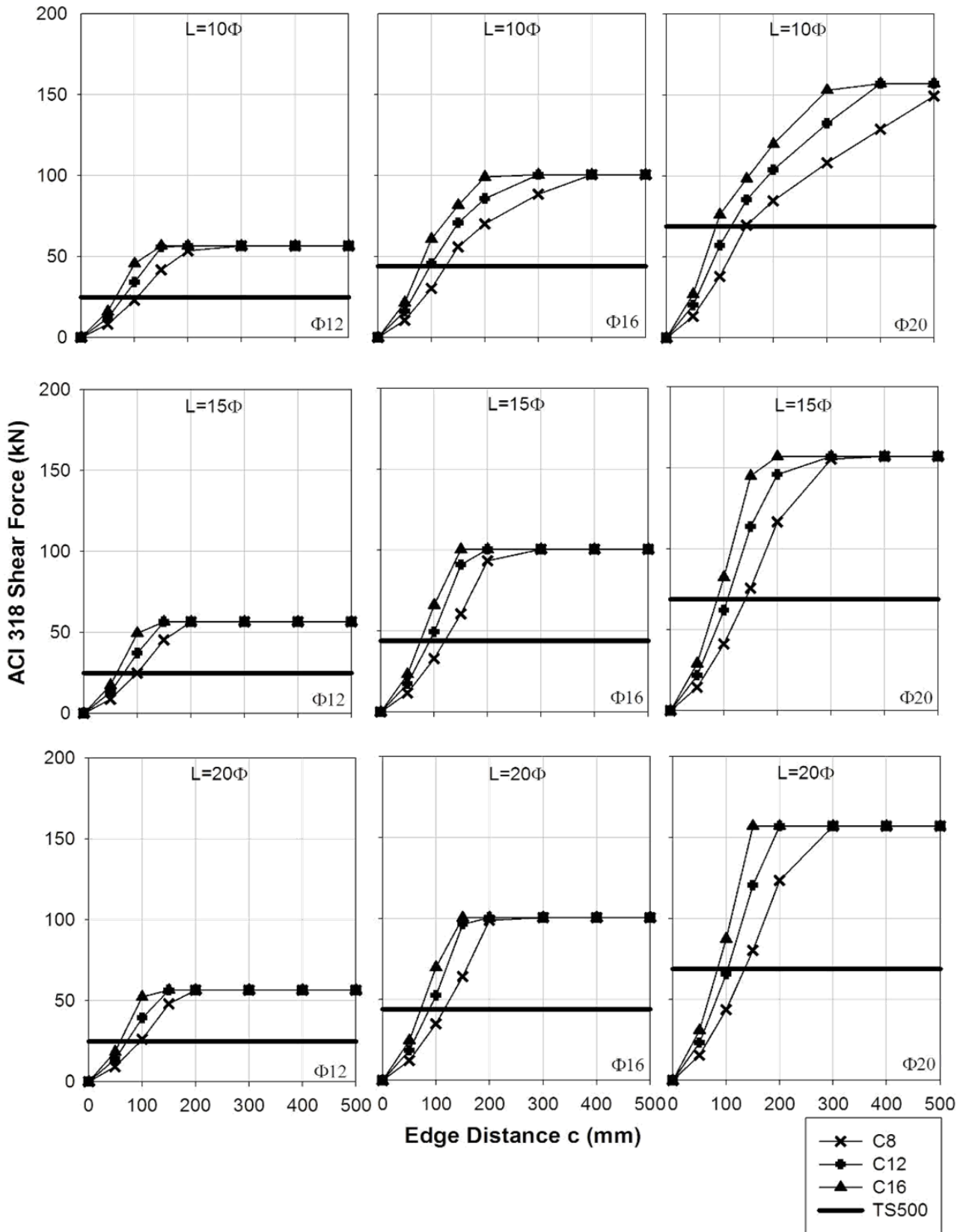

Fig. 4. ACI318 – TS500 shear forces with varying edge distances.

## 5. Conclusions

In this study, ACI318 and TS500 methods, which are used for determining anchor shear capacity, are compared for low strength base concrete. Current Turkish Earthquake Code (2007) references to sliding shear formula of TS500 for anchor capacity.

In ACI318 method, besides bar diameter and steel strength, concrete strength and the free edge distance of anchor are effective parameters for shear capacity. However, in TS500 formula, the anchor strength is not affected by concrete compressive strength and edge distance. As a result, the shear design of anchors with small free edge distance or embedded to low strength concrete according to TS500 may cause to misleading results. Therefore, an immediate revision is needed either in Turkish Earthquake Code or TS500.

From the results of this study, it is possible to conclude that TS500 formulae results in safe result for the most of the cases while free edge distance is higher than  $15\Phi$ . Therefore, designers can utilize either TS500 or ACI318 methods accordingly. However, it should be noted ACI capacity reduction factors were not utilized for this study. Use of those would definitely result in a worse condition for TS500 approach.

## Acknowledgement

This study has been supported by National Scientific and Technological Research Foundation of Turkey (TÜBİTAK) under grant number 107M572.

## REFERENCES

- ACI Committee 349 (1978). Code requirements for nuclear safety - related concrete structures and commentary.
- ACI Committee 355 (1991). State-of-the-Art Report on Anchor to Concrete, ACI 355.1R-91, American Concrete Institute, Detroit, MI.
- ACI318 (2008). Building Code Requirements for Reinforced Concrete, American Concrete Institute, Detroit, USA.
- Alqedra MA, Ashour AF (2005). Prediction of shear capacity of single Anchors located near a concrete edge using neural Networks. *Computers & Structures*, 83, 2495-2502.
- Cook RA, Collins D Mi, Klingner RE, Polyzois D (1992). Load-deflection behavior of cast-in-place and retrofit concrete anchors. *ACI Structural Journal*, November-December, 639-649.
- DBYYHY (2007). Deprem Bölgelerinde Yapılacak Yapılar Hakkında Yönetmelik, Bayındırlık ve İskan Bakanlığı, Ankara.
- Eligehausen R, Cook RA, Appl J (2006). Behavior and design adhesive bonded anchors. *ACI Structural Journal*, November-December, 822-831.
- Fuchs W, Eligehausen R, Breen JE (1995). Concrete capacity design (CCD) approach for fastening to concrete. *ACI Structural Journal*, 92(1), 73-94.
- Fujikake K, Nakayama J, Sato H, Mindess S, Ishibashi T (2003). Chemically bonded anchors subjected to rapid pullout loading. *ACI Materials Journal*, May-June, 246-252.
- Gürbüz T (2007). Yapıların Güçlendirilmesinde Kullanılan Kimyasal Ankrajların Eksenel Çekme Etkisi Altındaki Davranışlarının İncelenmesi. *M.Sc. thesis*, İstanbul Technical University, İstanbul (in Turkish).
- Kaya Y (2007). Yapıların Güçlendirilmesi Uygulamalarında Kullanılabilecek Kısmi Bağlı Ankraj Detayı ve Yüzey Temizliği Koşulları Altında Ankrajların Eksenel Çekme Davranışlarının İncelenmesi. *M.Sc. thesis*, İstanbul Technical University, İstanbul (in Turkish).
- McVay M, Cook RA, Krishnamurthy K (1996). Pullout simulation of postinstalled chemically bonded anchors. *Journal of Structural Engineering*, September, 1016-1024.
- Muratli, H, Klingner RE, Graves HL (2004). Breakout capacity of anchors in concrete-part 2: shear. *ACI Structural Journal*, November-December, 821-829.
- Özkul H, Mutlu M Sağlam AR (2001). Beton ankrajları, Sika Teknik Bülten Sayı 4.
- Özturan T, Gesoğlu M, Özel M, Güneyisi E (2004). Kimyasal, harçlı ve mekanik ankrajların çekme ve kesme yükleri altındaki davranışları. *İMO Teknik Dergi*, 208, 3105-3124..
- Primavera EJ, Pinelli JP, Kalajian EH. (1997). Tensile behavior of cast-in-place and undercut anchors in high-strength concrete. *ACI Structural Journal*, September-October, 583-594.
- TS500 (2000). Betonarme Yapıların Tasarım ve Yapım Kuralları. Türk Standartları Enstitüsü, Ankara.
- Ueda T, Kitipornchai S, Ling K (1990). Experimental investigation of anchor bolts under shear. *ASCE Journal of Structural Engineering*, 116(4), 910-924.
- Yılmaz S, Kaplan H (2009). Epoksi Ankraj Uygulamalarında dikkat edilmesi gerekli konular, İMO Denizli Bülten, Temmuz-Eylül.
- Zamora NA, Cook RA, Konz RC and Consolazio GR (2003). Behavior and design of single, headed and unheaded, grouted anchors under tensile load, *ACI Structural Journal*, March-April, 222-230.