

# Design and Performance Analysis of Peltier & Piezoelectric Human Energy Harvesting Hybrid Model for WBAN Application

Hardeep Singh Dhillon, and Paras Chawla

**Abstract**—Wireless body area network (WBAN) has evolved from Wireless personal area network (WPAN), a prominent area of research with vast applications in last decade. In WBAN, various wirelessly interconnected body node (BN) are implanted in or around the human body. Also due to advancement in technology a miniature low power device/BN is developed. The main challenge in WBAN body node is to maintain finite size of battery as well as to increase its capacity. Hence this issue can be resolved by using energy harvesting. Generally researchers have used piezoelectric, electromagnetic or solar harvester only. But, in this research energy harvesting using the hybrid optimization of Piezoelectric and Peltier sensors by controlling on-off timing of body nodes is introduced. A hybrid optimized algorithm is developed using MATLAB 2015b platform and extensive simulation is performed considering four different human gestures (relaxing, walking, running and fast running) which in turn improves overall Quality of Service (QoS) including average (packet loss, end to end delay, throughput) and overall detection efficiency.

**Keywords**—Wireless, Energy harvesting, Body node, Body node coordinator (BNC), Piezo-electric harvester, Peltier

## I. INTRODUCTION

THE research paper makes a brief overview on technologies related to energy harvesting including the current trend of internet of things (IoT) [1] and wireless sensor networks (WSNs). The IoT plays an essential role to define as well as transform the way people live and work, bringing extraordinary benefits to our daily life [2, 3]. Different human activities have been studied by conducting various simulations like (i.e. *relaxing, walking, running, and fast running*), which have resulted in various medical applications. The new energy harvesting technique using hybrid approach based on peltier and piezoelectric wireless sensing system is proposed. This proposed system will increase detection efficiency, average (throughput, energy efficiency) and will help in reducing average end-to-end delay during wireless data transmission. There are various challenges that must be removed first, so that Wireless body area networks can be implemented successfully.

In WBAN number of nodes and size is limited due to space constraints which in turn make difficult to adapt it seamlessly on human body. The size of anybody node is decided by battery weight which further represents battery capacity. Battery being finite source of energy, so when battery level drops the BN operation is firstly affected and in the end stops.

Authors are with Chandigarh University, Gharuan Mohali, Punjab, India (e-mail: 15yec1005@cumail.in; drparaschawla.ece@cumail.in).

So for smooth and continuous operation battery replacement or recharging becomes essential.

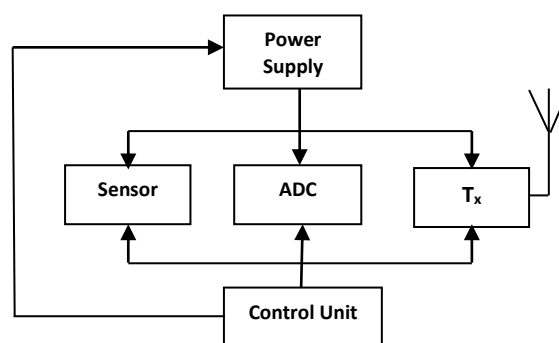

Fig. 1. Basic Architecture of proposed wireless sensor node.

### A. Self-Powered Wireless Sensor Node

Conventionally, power supplies and circuits including micro-controllers and voltage regulators are required by body sensor nodes. The basic architecture of proposed wireless sensor node is illustrated in figure. 1. Although the architecture may vary in different designs, this figure gives the concept that traditional wireless sensor nodes need controlling, power supply and data regulations. A considerable amount of research work has been performed on designing self-powered wireless sensor nodes to ease the maintenance burden and improve the lifetime of the power supply.

### B. Wireless body area network

In WBAN the body nodes are implanted in or around the human body. There is a major difference in deployment of sensor. Due to advancement in technology a miniature low power device BN is developed. The main challenge in WBAN body node is to maintain finite size of battery as well as to increase its capacity. Hence this issue is resolved by using energy harvesting. Mostly researchers used piezoelectric sensor, electromagnetic or solar harvester [21]. WBAN are one of the emerging technologies that can revolutionize many medical applications. WBANs can also be utilized in various fields including fitness, entertainment, military etc. The small size batteries create hindrance for sensors to sense, process, and store and then finally transmit the data. This in turn degrades the various parameters including overall energy efficiency, throughput and latency of the WBAN. The WBAN architecture consists of two modules as shown in figure. 2, include multiple interconnected body sensor units/nodes and a body central

unit. The body sensor nodes not only help in vital medical data acquisition but also pre-process the data. In intra-BAN [12] the body sensor units and the body central unit communicate with the help of Bluetooth. In Intra WBAN in Intra BAN communication range is 2 meter around person.

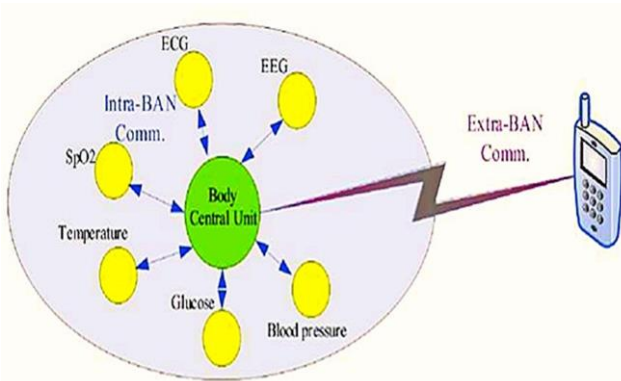

Fig. 2. WBAN Architecture under consideration

### C. IEEE 802.15.6

IEEE 802.15.6 is used as a standard internationally to develop communication model between various low power consumption devices/nodes implanted in or around human body. IEEE 802.15.6 defines international standard in term of short range, low power wireless communication. It uses international scientific medical band frequency approved by national medical as regulatory authority. Sensor and reader is based on 30  $\mu$ W analog signal processor and transceiver employs 1.9 nJ/b, 2.4 GHz processor supporting extremely low power data rate 10 Mbps.

## II. ENERGY HARVESTING

Energy harvesting is regarded as the most effective substitute to small batteries in WBAN. The environment and availability of various ambient energy sources decide the output power of the energy harvester. Hence some applications utilize harvested energy more efficiently than other. Depending on the application the possible sources for energy harvesting are selected and studied. In the process of energy harvesting very small amount of energy is converted from environment into electrical energy. Energy harvesters can also be regarded as miniature green power plants. The energy harvesting cannot precisely specify the amount of energy harvested. However, conventionally the amount of energy harvested for wireless sensor nodes or portable devices is very small in a mW power range. Due to the popularity and wide range of applications of low power wireless sensor networks, the technology has made it practical to develop an extremely low power sensor node. Traditionally, energy harvesters were developed decade long back. Firstly solar cells were developed in 1950s. After that the thermoelectric generators come in effect in 1960s, which were earlier used with nuclear batteries to power implanted pacemakers. Moreover the fundamental effects including photovoltaic and Seebeck effect [16] were used in energy harvesting. Industrial revolution in the 19th century leads to these effects. However, a complete sensor node was developed recently only consisting of electronic circuit with analog to digital converter (ADC), micro-

controller and radio transceiver that operates at low power. Hence energy harvesting concept from various sources is developed which further helps in recharging batteries without replacing. The energy harvester can be used to power any individual stand alone device, system or sensor nodes which consumes very low amount of power. There are many potential applications of energy harvesting. For physically inaccessible devices energy harvesting is very suitable.

On the other hand there are many challenges also in way of low power devices that must be removed first before using it. Firstly, implementing an energy harvesting device itself is very cumbersome task. Secondly, in most of the cases, availability of energy after harvesting is usually variable and unpredictable. So the energy source should be carefully selected after estimating their output power. Thirdly the output power and voltage are very low. They require conversion, scaling and adequate handling in order to be used by a sensor node. A dedicated Power management unit (PMU) is necessary to perform this operation. Finally, a matched load helps the energy harvesting to provide the maximum possible output power.

### A. Overview of Energy Harvesting Systems

As has been introduced already, energy harvesting technology is an approach by which electricity is produced from ambient energy. A generic system can be described as the one in figure. 3 The block diagram describes the general process of energy harvesting.

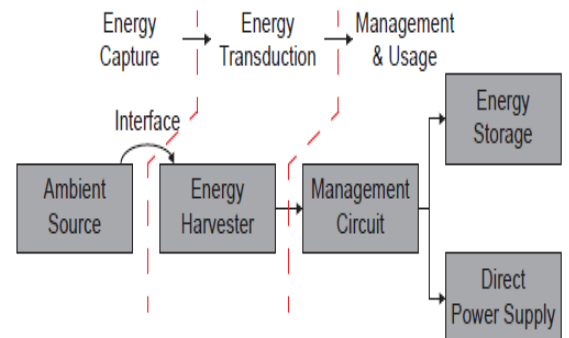

Fig. 3. Generic block diagram of an energy harvesting system

The first stage of the system is the energy capture stage. In this stage, initial energy from ambient sources are captured and delivered to the energy harvester through the transmission interface. The energy transduction stage is the main stage for energy harvesting. The energy harvesters then convert the captured energy to electrical energy via corresponding transduction [28]. The principle of the transmission interface and the transduction are dependent on the type of the initial energy and the ambient surroundings.

## III. PROPOSED WBAN MODEL

The proposed WBAN structure is developed, modeled and simulated using MATLAB 2015b simulation software. The proposed non-preemptive priority scheme has been implemented on a WBAN test bed based on Arduino Uno R3 platform with wireless enabled module. It works on 2.4 GHz IEEE 802.15.4 compatible radio support.

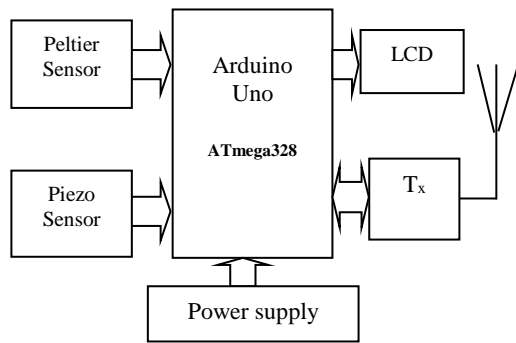

Fig. 4. Block Diagram of Transmission section (Tx)

Figure 4 shows block diagram of transmitter section. There will be one transceiver configured with one microcontroller at the patient end as shown in figure. 5 & figure. 6 Another one will be configured with another microcontroller and connected a PC/Laptop for a doctor to check.

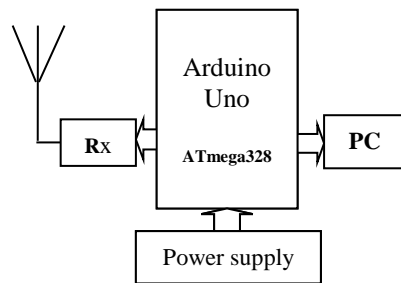

Fig. 5. Block Diagram of Receiver section (Rx)

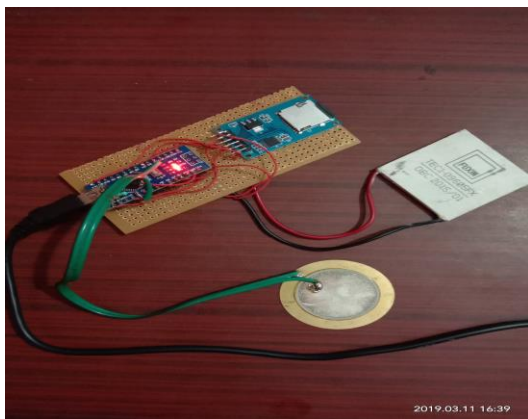

Fig. 6. Picture of body node developed

The patient end part consists of a microcontroller which will receive data from a piezo sensor and peltier sensor connected to it. The transceiver at this end will send data through the radio frequency network. Finally, the sensor nodes which are the sender nodes with the receiver nodes are configured with ATmega328. Alongside ATmega328 in the base station Arduino Promini is used as the programmer of the ATmega328 microcontrollers.

#### A. Data Transmission

The data sensed by sensor nodes is now transmitted to the remote server for analysis and sensing by the medical fraternity. Energy consumption during various processes of

data acquisition also depends on parameter which is being sensed by the sensor nodes. Whereas the energy consumed during data processing depends upon the hardware and the instruction set. Also, energy consumed during the process of wireless data communication summarizes energy consumed during data transmission and reception. Hence, it makes use of low power short range wireless communication technologies for communicating data from the interconnected sensor nodes to the server located at remote location. In accordance with the IEEE standards, the number of nodes may vary from 6 to 28 that a WBAN can support. The number of nodes is limited due to the network constraints like communicational protocols and network resources. The number of nodes in a WBAN can change depending upon their interaction with other WBANs and networks in the surrounding environment.

#### B. Energy model

The energy consumption of sensor nodes is negligible during data acquisition, minimum in data processing but maximum in data communication. Thus, more focus is given by the researchers on energy consumption during communication. Most of the energy is consumed in data transmission and reception. So, optimum resource allocation is required to fully utilize the harvested energy. It helps in improving the communication performance of WBANs in terms of higher throughput, longer network lifetime, and less wastage of harvested energy. Energy gained while transmission and reception of radio signals can also be harvested for powering the devices. However, this process interferes with data transmission. Hence, there is a tradeoff between rate of information transmission and harvested energy. Thus, it is suggested to have a balance between energy harvesting and information transmission for a reliable data transfer with continuous energy supply.

#### IV. DATA AGGREGATION

Aggregation, i.e., to combine, mainly focus on aggregating data at cluster heads to reduce the number of packets for transmission. Data collected by sensor nodes either relates to the sensor's specific location or data collected at multiple sensors over time. The aggregator node combines data from multiple sensors and is more powerful than the sensor nodes. Aggregator node can also act as an interface between the nodes by its sensing capabilities. Since data communication is more expensive than data processing, aggregator node can affirm rich information about the patient from data using data mining systems.

#### V. DATA ACQUISITION

In data acquisition the sensor collects data from the ADC the channel embedded inside the sensor node. The sampling rate controls the whole process, which indicates data collection frequency. A timer control manages overall data collection. For example, if the sampling rate is set as 40 Hz, this indicates that data collection takes place at every  $(1,000/40)$ , which is 25 ms. In the Best Effort mode, each packet transmission is counted and regarded as successful transmission. In Reliable mode every packet in the process of transmission is acknowledged. The MAC acknowledges every packet received.

## VI. RESOURCE MANAGEMENT

Resource management helps in controlling and management of various interconnected sensor nodes within the wireless sensor network. Sensor on-off and sensor toggle generates source control messages depending on the sensor's battery reading. When sensor on-off sleep command is generated it turns off the radio communication of the sensor node for a pre-defined time interval. Hence power is conserved as now sensor node is in sleep state. Further observation shows that the magnitude of energy used by radio communication is less than that of microcontroller. The MSP430F1611 microcontroller draws an approximately 1.8-mA current while operating in on state and 5.1  $\mu$ A in off state. On the other hand, the radio, CC2420, consumes up to 17.4 mA of current. Hence it minimizes the energy consumption of the sensor nodes to large extent.

## VII. POWER ENERGY AWARE MANAGEMENT QOS

There are three modules which include Power management, Data queue, and Packet compression.

**Power Management:** It manages harvested energy and keep node in Energy neutral operation (ENO) to obtain lifetime power for data detection and Transmission. Moreover node is said to be in ENO state if it consume less or equal amount of energy compared to the total energy harvested from environment.

**Data Queue:** Data queue module take care that only useful data is transmitted in time constraint. When data is transmitted in queue a fixed no of packets are allowed to be transmitted. Moreover the packets that are delayed above fixed delay threshold which are now irrelevant are ignored and not transmitted.

**Packet Compression:** In this step duplicate data packet address is transmitted instead of duplicate packet which leads to decrease in data congestion during transmission.

## VIII. SIMULATION AND RESULTS

All coding is done in MATLAB 2015b software. The main aim is to hybrid optimization of piezo and peltier by controlling on off timing of BN operation for various gestures including sitting, walking, running and fast running. We have taken two harvesters average power reading as shown in Table I & Table II considering four BN nodes placed at four different positions of human body.

TABLE I  
AVERAGE ENERGY HARVESTED BY PIEZO HARVESTER (mW)

BN	Relaxing	Walking	Running	Fast Running
1	19.989	124.986	252.139	302.807
2	20.028	125.111	252.014	301.863
3	19.963	124.815	252.246	302.123
4	20.016	125.099	252.458	302.260

Table II  
Average energy harvested by peltier harvester (mW)

BN	Relaxing	Walking	Running	Fast Running
1	2.992	7.480	10.979	20.045
2	3.011	7.521	11.032	20.024
3	3.007	7.510	11.012	19.963
4	2.982	7.481	11.045	19.969

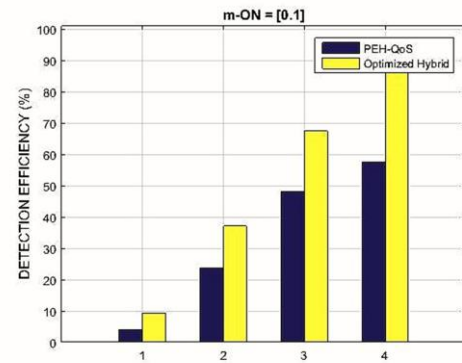

Fig. 7. Detection efficiency for various types of human activities before and after optimization.

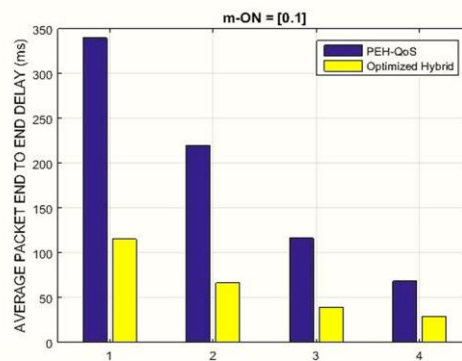

Fig. 8. Average packet end to end delay for various types of human activities before and after optimization.

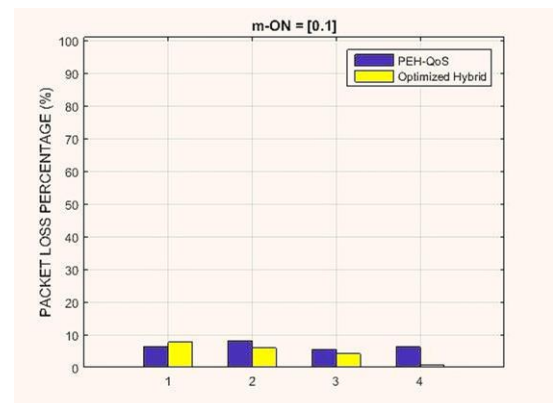

Fig. 9. Average Packet loss for various types of human activities before and after optimization.

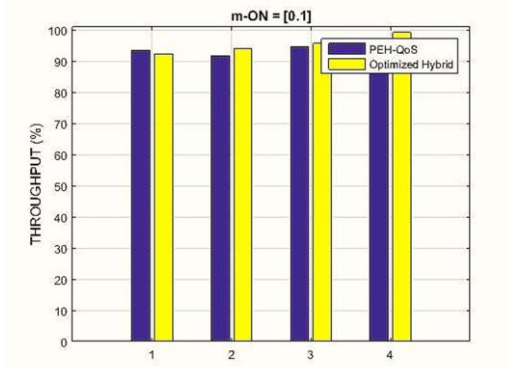

Fig. 10. Average Throughput for various types of human activities before and after optimization.

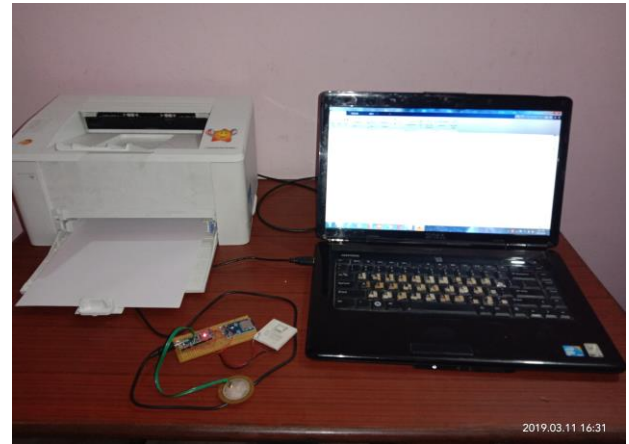

Fig. 13. Proposed working module of peltier and piezoelectric harvester hybrid model.

IX. CONCLUSION

This research aims at designing a motion-powered wireless sensing platform using piezoelectric and peltier energy harvesting. The platform reported here is completely powered by ambient motions at a random low frequency and temperature gradient which can transmit the sensing signal to a receiver when a suitable passive sensor is connected. The model is simulated using the Simulink module in MATLAB 2015b. Simulations results as shown in figure 7, 8, 9, 10, 11 & 12 shows that on an average detection efficiency for m-ON = .1 has increased ranging from 20% to 40% and average packet end-to-end delay has decreased ranging from 50% to 70 %. Since m-ON is variable a tradeoff can be obtained in future by varying m-ON depending on the applications.

REFERENCES

- [1] J. Gubbi, R. Buyya, S. Marusic, and M. Palaniswami, "Internet of things (IoT): A vision, architectural elements, and future directions," *Future Generation Computer Systems*, vol. 29, no. 7, pp. 1645-1660, 2013.
- [2] Hype cycle for the internet of things, 2015. Gartner. Accessed: 2015-08-03.
- [3] Winning with the industrial internet of things. Accenture. Accessed: 2015-08-03.
- [4] Unlocking the potential of the internet of things. McKinsey Global Institute. Accessed: 2015-08-04.
- [5] C. Swedberg. Michelin uses RFID to track tire pressure and tread for London bus company. Accessed: 2015-08-04.
- [6] M. Allen, A. Preis, M. Iqbal, and A. J. Whittle, "Water distribution system monitoring and decision support using a wireless sensor network," in *Software Engineering, Artificial Intelligence, Networking and Parallel/Distributed Computing (SNPD)*, 2013 14th ACIS International Conference on. IEEE, 2013, pp. 641-646.
- [7] A. Z. Abbasi, N. Islam, Z. A. Shaikh, "A review of wireless sensors and networks' applications in agriculture," *Computer Standards & Interfaces*, vol. 36, no. 2, pp. 263-270, 2014. 145
- [8] P. D. Mitcheson, E. M. Yeatman, G. K. Rao, A. S. Holmes, and T. C. Green, "Energy harvesting from human and machine motion for wireless electronic devices," *Proceedings of the IEEE*, vol. 96, no. 9, pp. 1457-1486, 2008.
- [9] Observ'ER, "Worldwide electricity production from renewable energy sources," 13th inventory, 2013.

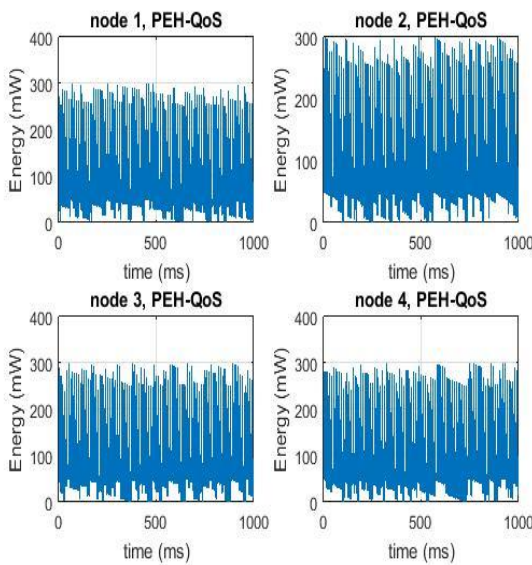

Fig. 11. Average Energy Efficiency for various types of human activities before optimization.

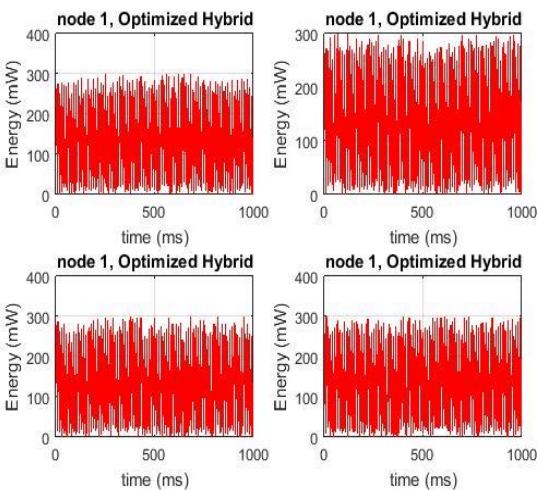

Fig. 12. Average Energy Efficiency for various types of human activities after optimization.

In order to evaluate and validate the proposed hybrid peltier and piezoelectric harvester as shown in Figure. 13 in a convenient way, an equivalent circuit model is built.

- [10] S. P. Beeby, M. J. Tudor, and N. White, "Energy harvesting vibration sources for Microsystems applications," *Measurement science and technology*, vol. 17, no. 12, p. R175, 2006.
- [11] J. Paradiso, T. Starner, "Energy scavenging for mobile and wireless electronics," *Pervasive Computing, IEEE*, vol. 4, no. 1, pp. 18-27, 2005.
- [12] G.-Z. Yang and M. Yacoub, *Body sensor networks*, 2nd ed. Springer, 2014.
- [13] R. Riemer and A. Shapiro, "Biomechanical energy harvesting from human motion: theory, state of the art, design guidelines, and future directions," *Journal of neuro-engineering and rehabilitation*, vol. 8, no. 1, p. 22, 2011.
- [14] M. Lossec, B. Multon, and H. B. Ahmed, "Sizing optimization of a thermoelectric generator set with heat sink for harvesting human body heat," *Energy Conversion and Management*, vol. 68, pp. 260- 265, 2013.
- [15] V. Leonov, "Thermoelectric energy harvesting of human body heat for wearable sensors," *Sensors Journal, IEEE*, vol. 13, no. 6, pp. 2284-2291, 2013.
- [16] M.-K. Kim, M.-S. Kim, S. Lee, C. Kim, and Y.-J. Kim, "Wearable thermoelectric generator for harvesting human body heat energy," *Smart Materials and Structures*, vol. 23, no. 10, p. 105002, 2014.
- [17] A. Almusallam, R. Torah, D. Zhu, M. Tudor, and S. Beeby, "Screen printed piezoelectric shoe-insole energy harvester using an improved edible PZT-polymer composites," in *Journal of Physics: Conference Series*, vol. 476, no. 1. IOP Publishing, 2013, p. 012108. 146
- [18] J. Kymissis, C. Kendall, J. Paradiso, and N. Gershenfeld, "Parasitic power harvesting in shoes," in *Wearable Computers, 1998. Digest of Papers. Second International Symposium on. IEEE, 1998*, pp. 132-139.
- [19] N. S. Shenck and J. A. Paradiso, "Energy scavenging with shoe mounted piezoelectrics," *IEEE micro*, no. 3, pp. 30-42, 2001.
- [20] A. Luque and S. Hegedus, *Handbook of photovoltaic science and en-gineering*. John Wiley & Sons, 2011.
- [21] R. Bube, *Fundamentals of solar cells: photovoltaic solar energy con- version*. Elsevier, 2012.
- [22] J. You, L. Dou, K. Yoshimura, T. Kato, K. Ohya, T. Moriarty, K. Emery, C.-C. Chen, J. Gao, G. Li et al., "A polymer tandem solar cell with 10.6% power conversion efficiency," *Nature communications*, vol. 4, p. 1446, 2013.
- [23] H.-S. Kim, C.-R. Lee, J.-H. Im, K.-B. Lee, T. Moehl, A. Marchioro, S.-J. Moon, R. Humphry-Baker, J.-H. Yum, J. E. Moser et al., "Lead iodide perovskite sensitized all-solid-state submicron thin film mesoscopic solar cell with efficiency exceeding 9%," *Scientific reports*, vol. 2, 2012.
- [24] D. A. R. Barkhouse, O. Gunawan, T. Gokmen, T. K. Todorov, and D. B. Mitzi, "Device characteristics of a 10.1% hydrazine-processed Cu<sub>2</sub>ZnSn(Se, S)<sub>4</sub> solar cell," *Progress in Photovoltaic: Research and Applications*, vol. 20, no. 1, pp. 6-11, 2012.
- [25] I. Repins, M. A. Contreras, B. Egaas, C. DeHart, J. Scharf, C. L. Perkins, B. To, and R. Noufi, "19.9%-efficient ZnO/CdS/CuInGaSe<sub>2</sub> solar cell with 81.2% fill factor," *Progress in Photovoltaics: Research and applications*, vol. 16, no. 3, pp. 235-239, 2008.
- [26] S. Roundy, E. S. Leland, J. Baker, E. Carleton, E. Reilly, E. Lai, B. Otis, J. M. Rabaey, P. K. Wright, and V. Sundararajan, "Improving power output for vibration-based energy scavengers," *Pervasive Computing, IEEE*, vol. 4, no. 1, pp. 28-36, 2005. 147
- [27] K. Uchida, S. Takahashi, K. Harii, J. Ieda, W. Koshibae, K. Ando, S. Maekawa, and E. Saitoh, "Observation of the spin Seebeck effect," *Nature*, vol. 455, no. 7214, pp. 778-781, 2008.
- [28] D. M. Rowe, *Thermoelectrics handbook: macro to nano*. CRC press, 2005.