

Measuring Impedances of DC-biased Inductors by Using Vector Network Analyzers

G. Asmanis, D. Stepins, A. Asmanis, and L. Ribickis

Abstract—This paper is devoted to a detailed experimentally based analysis of applicability of vector network analyzers for measuring impedance of surface mount inductors with and without DC bias. The measurements are made using custom-made bias tees and a test fixture with an ordinary vector network analyzer. The main attention in the analysis is focused on measurement accuracy of an impedance of surface mount inductors. Measurement results obtained with a vector network analyzer will also be compared to those obtained by using an impedance analyzer based on auto-balancing bridge method.

Keywords—vector network analyzer, impedance, inductor, measurements, accuracy, bias tee

I. INTRODUCTION

WE cannot imagine our lives without electronics. Nowadays various electronic devices have become integral parts of our life. They are all equipped with both active and passive electronic components including inductors. Due to inductors' ability to store electric energy in magnetic field and to have high impedance at high frequencies, they are often used in passive electric filters (including passive electromagnetic interference filters), switch-mode power converters, LC resonant tanks, DC bias tees and so on. There are several important applications of inductors in which current passing through them has both AC and DC components. Since relative magnetic permeability of a magnetic core material is magnetic-field-strength-dependant, inductance of a cored inductor depends on a current DC component (especially at high DC currents).

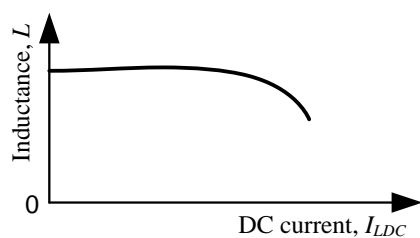

Fig. 1. Typical inductance versus DC current curve for an inductor with magnetic core.

Typical inductance versus DC current curve is depicted in Fig. 1. At high DC currents passing through inductors, magnetic core material can saturate. As consequence,

G. Asmanis, A. Asmanis and L. Ribickis are with the Institute of Industrial Electronics, Riga Technical University, Riga, Latvia.

D. Stepins is with the Institute of Radio Electronics, Riga Technical University, Riga, Latvia. (e-mail: deniss.stepins@rtu.lv).

This paper is partly based on a PhD thesis "Surface-Mount Component 3D Modelling in Frequency Range 150 kHz-100 MHz" defended by A. Asmanis in 2018 in the Riga Technical University.

inductor's inductance can drop drastically. If inductors are used in devices such as electromagnetic interference filters or switch-mode power converters, then it is very important to know impedance of the inductor and inductance for different DC current values.

Inductor complex impedance with either zero DC bias or non-zero DC bias is often measured over wide frequency range. Typical inductor impedance magnitude ($|Z_L|$) as function of frequency is shown in Fig. 2. For frequencies below inductor self-resonant frequency impedance of the inductor increases as frequency increases (the inductor behaves as normal inductor), but for frequencies above the self-resonant frequency impedance of the inductor decreases (inductor behaves like a capacitor).

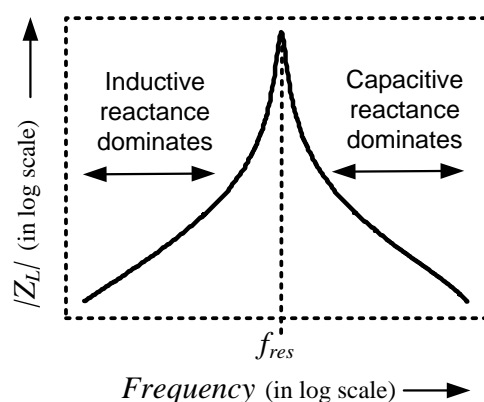

Fig. 2. Typical inductor impedance magnitude versus frequency over wide frequency range.

From complex impedance measurements, many useful parameters of an inductor can be calculated. They are mainly inductance (L), parasitic self-capacitance (C_{self}), self-resonant frequency (f_{res}), quality factor (Q) and so on.

Measurements of inductor impedances in radio-frequency (RF) range are often done by using impedance analyzers [1], [2]. Impedance analyzers based on either auto balancing bridge method or RF I-V method [2] can be used to measure impedance of inductors, inductance and other complex-impedance-related parameters over wide range of frequencies. Impedance analyzers with auto balancing bridge method have high measurement accuracy but are very expensive and have quite limited frequency range (usually up to 120 MHz) [2]. RF-I-V-method-based impedance analyzers have broader frequency range (up to few GHz) and are less expensive but have lower impedance measurement accuracy than impedance analyzers with auto balancing bridge method [2]. Despite good impedance measurement accuracy that can be achieved when using impedance analyzers (especially based on auto balancing

bridge method), they are relatively expensive and are not versatile (they e.g. cannot measure scattering (S) parameters of n-port networks). In contrary to impedance analyzers, vector network analyzers (VNAs) (that are primarily used to measure S parameters of one or two port networks) are much more versatile than impedance analyzers, usually are less expensive and may be used over wider frequency range than impedance analyzers.

As such, VNAs are intended for measuring S parameters of RF and microwave devices (e.g. filters, mixers, antennas, etc.). However, there are several research papers and application notes demonstrating measurements of capacitor impedance, parameters of inductors and complex magnetic permeability of magnetic core materials by using VNAs [3] – [7]. Despite the fact that a technique that can be used with VNAs to measure parameters of DC biased inductors was proposed in [7], effectiveness of the technique for DC biased inductors impedance measurements was not sufficiently shown because accuracy of the technique over wide frequency range was not analyzed. Moreover the technique proposed in [7] relied on the use of a VNA with special software – a test fixture simulator. The main original contribution of this paper is analysis of applicability of a typical VNA (without test fixture simulator or other dedicated software) for measuring impedance and inductance of DC-biased inductors. The main attention in the analysis will be focused on measurement accuracy of an impedance of surface mount inductors. Measurement results obtained with VNA will also be compared to those obtained by using an impedance analyzer.

II. EXPERIMENTAL SETUP

In order to show applicability of a typical VNA for measuring impedance of DC-biased inductors and analyze accuracy of the measurements, an experimental setup was created as shown in Fig. 3. A block diagram of the experimental setup is depicted in Fig. 4. The experimental setup is noticeably modified version of a setup presented in [7].

The experimental setup consists of two DC blockers (BLK-89-S+ from Mini-Circuits), two passive filters (Fig. 5), a DC power supply with built-in ammeter, VNA Rohde & Schwarz ZVRE and home-made test fixture with two SMA connectors. The DC blockers and the passive filters form two bias tees. The DC blockers are used to prevent DC currents from passing to the VNA ports. The passive filters are designed and created by us. A schematic diagram of the filter is presented in Fig. 6. The filter consists of some capacitors, inductors and resistors. The inductors block shunt paths to ground (via low internal impedance of the power supply) for RF signals going from the VNA port 1. To provide high impedance for the RF signals over wide frequency range (100 kHz – 1 GHz) four inductors with different inductance and self-capacitance values are used. The resistors are used to dampen parasitic resonances in the filters. The capacitors together with the inductors create low-pass filter to block RF conducted emissions from the power supply and thus to get more accurate measurement results.

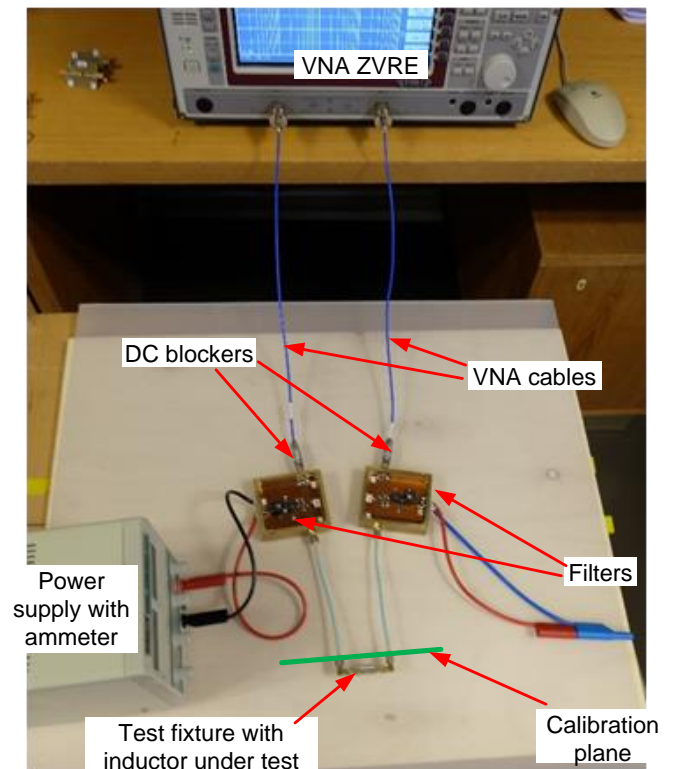

Fig. 3. Image of the experimental setup.

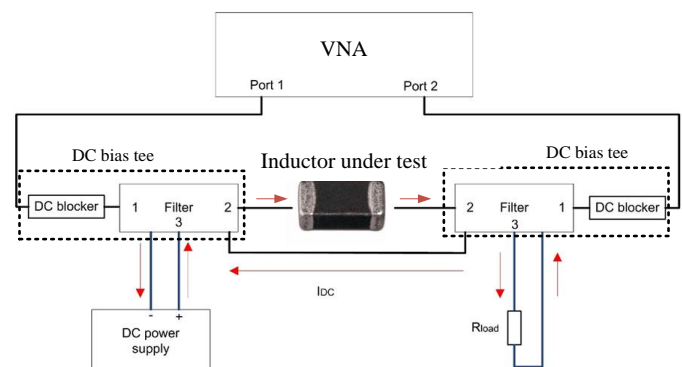

Fig. 4. Block diagram of the experimental setup.

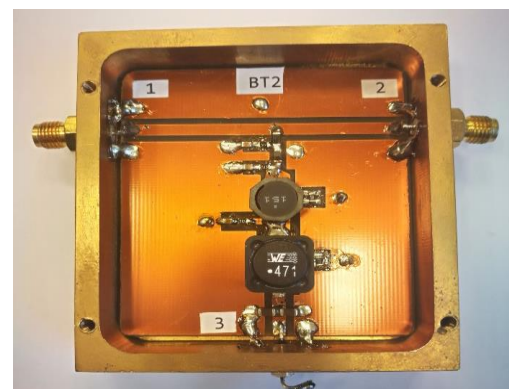

Fig. 5. Image of the filter (when front cover is removed) used in the experimental setup.

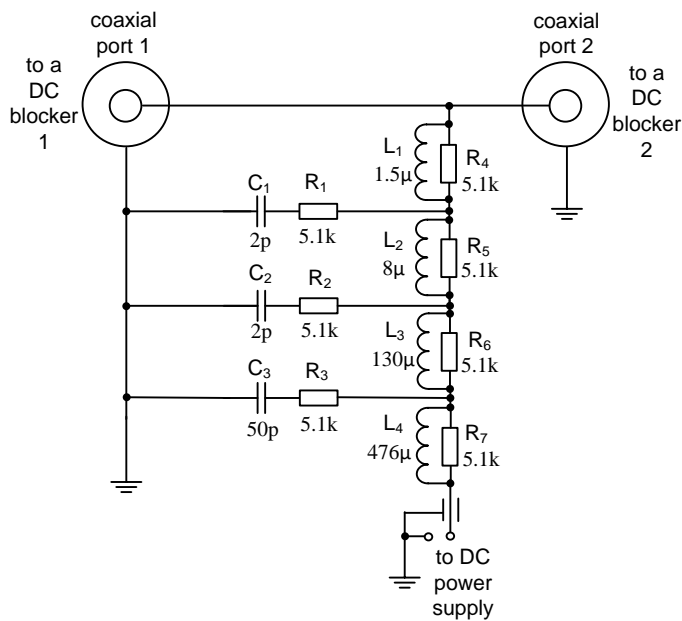

Fig. 6. Schematic diagram of the filter shown in Fig. 5.

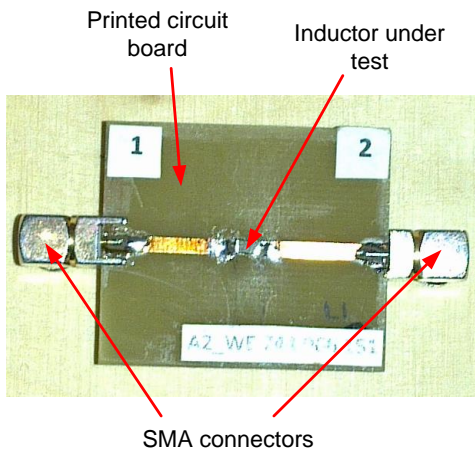

Fig. 7. Top view image of the test fixture with an inductor under test. Note: shields of the SMA connectors are connected to a ground plane at the bottom of the test fixture.

Surface mount inductor under test can be connected to the test fixture (Fig.7) by using soldering. Dielectric substrate of the test fixture is made of FR4 glass epoxy. The test fixture has two SMA connectors and it can be connected to the filters using SMA cables. The test fixture is designed by us to provide series-through measurements with VNA, because the series-through VNA technique is more suitable for making accurate measurements of high-impedance components [4], [6].

To make measurement of impedances at zero DC bias the test fixture with the inductors was directly connected to the VNA ports via coaxial cables (shown in blue in Fig. 3). To make measurement of impedances with DC bias the test fixture with the inductors was connected to the VNA ports via the bias tees (Fig. 3). In both cases through-open-short-matched (TOSM) calibration was performed using dedicated Rohde and Schwarz SMA calibration kit. In the former case calibration plane was at the ends of SMA connectors of the VNA cables

(shown in blue in Fig. 3). In this case the calibration was used to significantly reduce systematic errors due to non-idealities of the VNA cables and the coaxial connectors. In the latter case calibration plane was at the ends of SMA connectors of coaxial cables connected to the bias tees. In this case the calibration is used not only to eliminate systematic errors caused by parasitics of the VNA cables and their connectors, but also to significantly reduce the effect of the DC blockers, bias tees and the power supply on the measurement results. It should be noted that the calibration was not able to reduce systematic errors induced by the test fixture because we had SMA calibration kits, so de-embedding of the test fixture will be performed for this purpose.

III. EXPERIMENTAL RESULTS AND DISCUSSION

Measurements of impedances were performed for two different commercially available surface mount inductors: shielded power inductor WE 744066151 and ferrite bead WE 742792141. Both inductors are manufactured by the Würth Electronics. According to the manufacturer data sheets, the former has inductance of $150 \mu\text{H} \pm 30\%$ (at 100 kHz with zero DC bias), but the latter has impedance of $1 \text{ k}\Omega \pm 25\%$ (at 100 MHz with zero DC bias).

After the VNA warm-up time of one hour and TOSM calibration of the experimental setup as described previously, impedances of both inductors were measured using the VNA at different DC biases. Impedance of the inductor WE 744066151 was measured in frequency range from 300 kHz to 200 MHz, but impedance of the ferrite bead WE 742792141 was measured in frequency range 1 MHz ... 200 MHz. In order to estimate accuracy of the measurements the measurement results were compared to that obtained by using high-accuracy auto-balancing-bridge-technique-based impedance analyzer Keysight E4990A with a high-quality test fixture Keysight 16047E. The impedance analyzer can measure impedance in frequency range up to 120 MHz. In order to make accurate measurements with the impedance analyzer the test fixture was compensated (using open-short compensation method). For measuring impedance with the impedance analyzer the inductors under test were unsoldered from the VNA test fixture and mechanically connected to the impedance analyzer test fixture after compensation. Please note that the test fixture Keysight 16047E is for leaded components. However since we did not have a test fixture for surface mount components, the test fixture Keysight 16047E was used instead. In order to connect the surface mount inductors under test to the impedance analyzer test fixture, very short but thick leads (having very low inductance and resistance) were soldered to the components. Since impedances of the inductors under tests in the frequency ranges are much higher than impedances of the short leads, measurement uncertainty due to the short leads is very low and can be neglected.

Impedances of the inductors were measured for different DC bias currents in range 0 ... 100 mA using the VNA and the impedance analyzer. Note that the experimental setup depicted in Fig. 3 can be used to measure impedances of the inductors for DC biases up to 1A, but the impedance analyzer with the internal DC bias source can be used for DC biases up to 100 mA only.

Complex impedances of the inductors were indirectly measured with the VNA in two cases:

- when the test fixture (Fig. 7) effects were ignored (without de-embedding of the test fixture parasitics from the measurements);
- when the test fixture was de-embedded from the measurements in order to reduce significantly the test fixture effects on the measured impedances of the inductors under test.

In the former case complex impedance (Z_L) of the inductors can be obtained from measured complex transmission coefficient (S_{21}) for series-through technique [4] as follows:

$$Z_L = 100 \frac{1 - S_{21}}{S_{21}}. \quad (1)$$

Probably (1) may give good results for lower frequency range, however for higher frequency range (1) can be relatively inaccurate because the effect of the test fixture parasitics (especially parasitic capacitances) on measured transmission coefficients may be significant. Thus, for more accurate results the test fixture de-embedding from the measurements is of importance.

As such, de-embedding can be done using either 3D electromagnetic modeling software (e.g. CST MWS) or by creating accurate equivalent circuit model of the test fixture [10]. The latter is usually more popular because it is the cheapest solution. However not always it is easy to create accurate equivalent circuit model of a test fixture. For example, in our case it is quite difficult to create very accurate test fixture equivalent circuit model, because it consists of multiple elements: two SMA connectors, two SMA to microstrip line transitions and two microstrip lines. In this paper for the test fixture de-embedding approximate yet simple equivalent circuit model will be used. The model parameters (parasitic resistances, conductances, inductances and capacitances) will be experimentally determined from opened and shorted test fixture measurements. Equivalent circuit model of the experimental setup including the test fixture parasitics is depicted in Fig. 8. Note that in the model it is assumed that a calibration plane is at the ends of the coaxial cables connected to the test fixture SMA connectors and that the calibration eliminates systematic errors due to the bias tees and the cables. The test fixture parasitics are represented as passive elements in the model (Fig. 8). The test fixture parasitic parameters values can be determined either analytically, by using numerical modeling or via experimental measurements. We will use the latter approach to determine the test fixture parasitic parameters values as follows:

- in order to determine parasitic complex impedances Z_{11s1} and Z_{11s2} , complex impedance Z_{11s} of shorted test fixture was measured using the VNA and assuming that $Z_{11s1} = Z_{11s2}$, they were determined by dividing Z_{11s} by 2 [note that 1) Z_{11s} was measured when instead of the inductor under test a copper wire was soldered to the test fixture and one of the SMA connectors was shorted; 2) in reality Z_{11s1} is not equal to Z_{11s2} , they differ slightly one from another, so assumption that $Z_{11s1} = Z_{11s2}$ may introduce small error to the results after the de-embedding];

- parasitic complex impedances Z_{11p1} and Z_{11p2} of the test fixture (Fig. 7) were measured using the VNA when the inductors under test were removed from the test fixture.

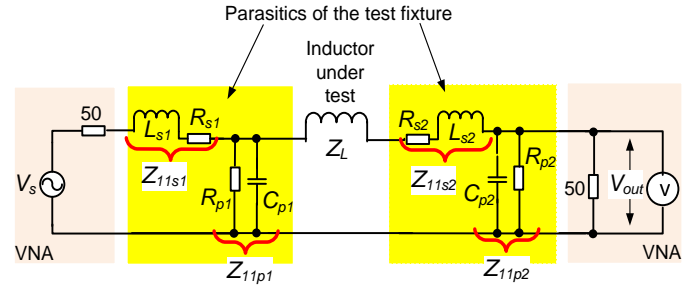

Fig. 8. Equivalent circuit model of the experimental setup including the test fixture parasitics. Note: the model is approximate.

Based on the equivalent circuit model of the experimental setup an equation was derived as follows:

$$V_{out} = V_s \frac{bZ_{11tot2}}{(a + Z_L)(b + 50 + Z_{11s1})}, \quad (2)$$

where V_s and V_{out} are the source voltage and the output voltage complex amplitudes respectively,

$$Z_{11tot2} = \frac{1}{\frac{1}{Z_{11p2}} + 0.02}, \quad (3)$$

$$a = Z_{11tot2} + Z_{11s2}, \quad (4)$$

$$b = \frac{1}{\frac{1}{a + Z_L} + 1/Z_{11p1}}. \quad (5)$$

Taking into account that $\frac{V_{out}}{V_s} = \frac{s_{21}}{2}$ [3], (2) can be rewritten as follows:

$$s_{21} = 2 \frac{bZ_{11tot2}}{(a + Z_L)(b + 50 + Z_{11s1})}. \quad (6)$$

The equation can be solved with respect to the inductor complex impedance Z_L either analytically or numerically. Using Matlab, (6) was solved numerically and values of the inductor impedance were calculated.

Since impedance of the inductor WE 744066151 weakly depends on DC bias currents up to 100 mA, it is depicted in Fig. 9 only for DC bias of 100 mA. Additionally, the ferrite bead WE 742792141 impedance versus frequency measured using the VNA and the impedance analyzer for DC bias of 0 and 100 mA is shown in Fig. 10. Note that impedances of the inductors measured by using the VNA are shown in the figures without de-embedding (with effects of the VNA test fixture parasitics) and with de-embedding (with reduced effects of the test fixture parasitics).

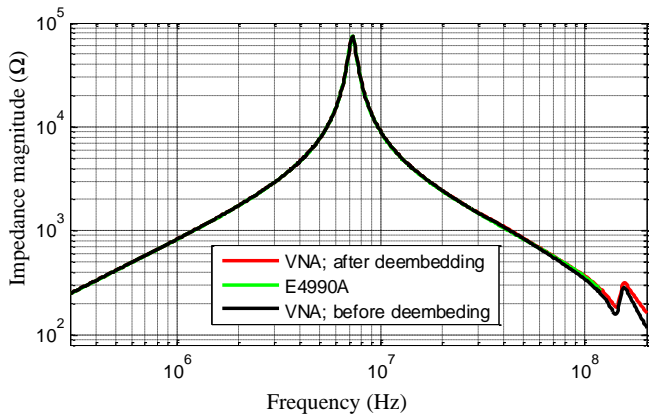

Fig. 9. Measured impedance magnitude of the inductor WE 744066151 versus frequency for DC bias of 100 mA. Note: impedance was measured with E4990A in frequency range 300 kHz – 120 MHz and with the VNA in frequency range 300 kHz – 200 MHz.

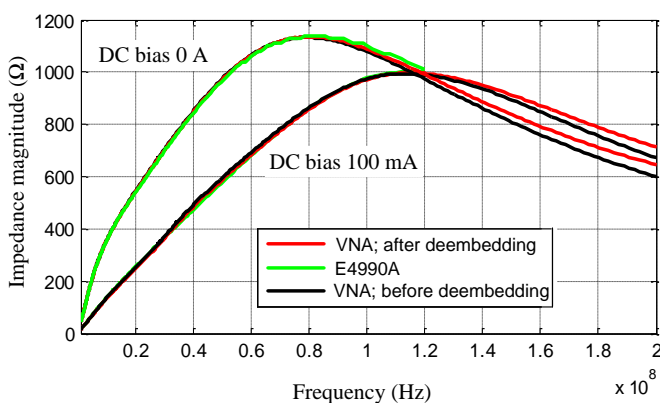

Fig. 10. Measured impedance magnitude of the ferrite bead WE 742792141 versus frequency for DC bias of 0 and 100 mA. Note: impedance was measured with E4990A in frequency range 1 MHz – 120 MHz and with the VNA in frequency range 1 MHz – 200 MHz.

Table I shows comparison of inductance (L) and resonant frequency (f_{rez}) for the inductor WE 744066151 obtained from the impedance measurements using both the impedance analyzer and the VNA. Since for the inductors at frequencies of some hundreds of kHz capacitive reactance and resistance does not have noticeable effect on the impedance, the inductor L was calculated at 300 kHz by dividing impedance magnitude at that frequency by $2\pi f$ (where $f = 300 \text{ kHz}$).

Table I
COMPARISON OF THE MEASUREMENT RESULTS FOR INDUCTOR WE 744066151

Method	L (at 300 kHz), μH	f_{rez} , MHz
Auto balancing bridge (E4990A)	131.89	7.22
VNA (without de-embedding)	132.11	7.26
VNA (with de-embedding)	132.11	7.26

The measurement results obtained by the VNA after the de-embedding of the test fixture (Fig. 9 and Fig. 10) have a good match with the results obtained by using the impedance analyzer over broad frequency range. The measurement results obtained by the VNA without the de-embedding of the test fixture are also in a good agreement with the results obtained by using the impedance analyzer at lower frequencies,

however at higher frequencies $>100 \text{ MHz}$ there is noticeable disagreement between the results when the test fixture is not de-embedded. It should be noted that good agreements between measured inductances and self-resonant frequencies are also obtained using both methods even when the de-embedding is not used.

In order to analyze measurement accuracy of the inductors impedance in more details, relative difference between measured impedance magnitudes was calculated as follows:

$$\varepsilon_{dif} [\%] = \frac{Z_{LVNA} - Z_{LABB}}{Z_{LABB}} \cdot 100, \quad (7)$$

where Z_{LVNA} is impedance magnitude obtained by using the VNA and Z_{LABB} is impedance magnitude obtained by using the impedance analyzer (with auto-balancing bridge method). $|\varepsilon_{dif}|$ with de-embedding and without de-embedding are presented in Fig. 11 and Fig. 12 for the inductor WE 744066151 (DC bias of 100 mA) and for the ferrite bead WE 742792141 (DC bias of 0 A) respectively. In the figures absolute value of relative measurement accuracy ($|\varepsilon_{ABB}|$) of the inductors impedances with the impedance analyzer are also shown. The measurement accuracy was calculated based on the expressions presented by the Keysight Technologies in [8] and [9] as follows:

$$\varepsilon_{ABB} = \pm(\varepsilon_{IA} + \varepsilon_{TF}), \quad (8)$$

where ε_{IA} is the impedance analyzer measurement accuracy (at 4-terminal pair port) and ε_{TF} is the test fixture 16047E additional error as follows [8], [9]:

$$\varepsilon_{IA} = E_{p1} + \left(\frac{Z_{s1}}{|Z_L|} + Y_{o1} \cdot |Z_L| \right), \quad (9)$$

$$\varepsilon_{TF} = E_{p2} + \left(\frac{Z_{s2}}{|Z_L|} + Y_{o2} \cdot |Z_L| \right), \quad (10)$$

where E_{p1} , Z_{s1} and Y_{o1} are the impedance analyzer proportional error, short repeatability and open repeatability respectively; E_{p2} , Z_{s2} and Y_{o2} are the test fixture proportional error, short repeatability and open repeatability respectively. Numerical values of the parameters are functions of the impedance analyzer internal oscillator level, frequency, device under test impedance magnitude, measure time and DC bias current range. They can be calculated based on the expressions presented in [8] and [9].

Presented results in Fig. 11 and Fig. 12 lead to a conclusion that impedances (exceeding 150 ... 200 Ω) of inductors (with or without DC bias) can be measured by using a standard VNA with the series-through technique with accuracy not lower than using today's high-accuracy impedance analyzers with auto-balancing bridge method if proper de-embedding of a VNA test fixture is used. It is interesting to see that the de-embedding of the VNA test fixture in overall can improve noticeably the measurement accuracy (especially at higher frequencies), however since the VNA test fixture model used in the paper is not very accurate, the test fixture de-embedding sometimes leads to worse measurement accuracy at some frequency ranges (e.g. at frequency range 1 ... 1.5 MHz as

may be seen in Fig. 12). So if it is necessary to get higher impedance measurement accuracy with a VNA it is recommended to use more accurate VNA test fixture model than used in this paper. It should be noted that the results shown in Fig. 11 and Fig. 12 do not allow us to determine the measurement uncertainties of the inductors impedances accurately when the VNA was used. The figures allow us to estimate the uncertainties approximately. For example, since for the inductor WE 744066151 after the de-embedding $|\varepsilon_{dif}| < |\varepsilon_{ABB}|$, it can be concluded that the inductor impedance measurement uncertainty when the VNA is used is not higher than the measurement uncertainty ($|\varepsilon_{ABB}|$) when the impedance analyzer is used (e.g. from Fig. 11 it follows that an uncertainty of the inductor WE 744066151 impedance measurement by using the VNA is $<0.6\%$ if $f=400$ kHz).

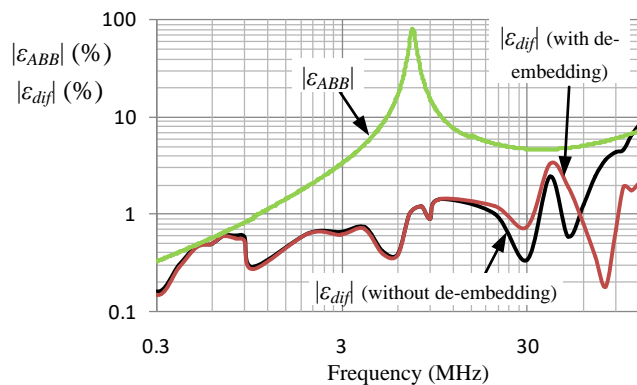

Fig. 11. $|\varepsilon_{ABB}|$, $|\varepsilon_{dif}|$ without and with de-embedding of the VNA test fixture as functions of frequency for the inductor WE 744066151 (DC bias 100 mA).

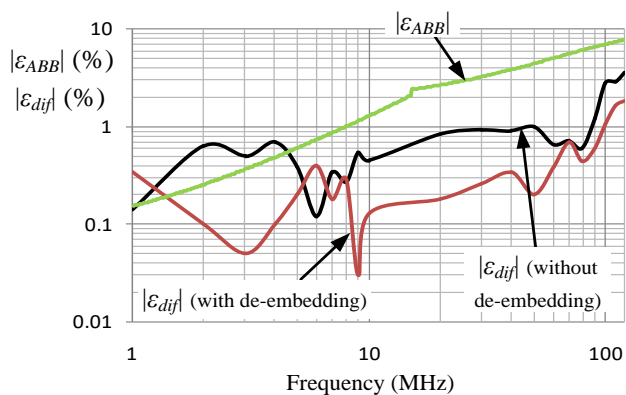

Fig. 12. $|\varepsilon_{ABB}|$, $|\varepsilon_{dif}|$ without and with de-embedding of the VNA test fixture as functions of frequency for the ferrite bead WE 742792141 (no DC bias).

IV. CONCLUSIONS

The results presented in the paper lead to a conclusion that impedances (exceeding 150 ... 200 Ω) of inductors (with or without DC bias) can be successfully measured by using standard VNA (even without a test fixture simulator or other dedicated software) with the series-through technique with accuracy not lower than using modern impedance analyzers with auto-balancing bridge method if proper de-embedding of a VNA test fixture is used and the VNA is calibrated properly. In broad frequency range the impedance measurement accuracy with the VNA is below 10 %. Accuracy below 1 % can even be achieved when VNA is used.

REFERENCES

- [1] Testing Chokes and Transformers with High-Current DC Bias. https://www.voltech.com/Articles/104-160/2_The_Effect_of_DC_Bias_on_Inductance_Measurements
- [2] K. Okada and T. Sekino. Impedance Measurement Handbook. Agilent Technologies, 2006.
- [3] Ultra Low Impedance Measurements Using 2-Port Measurements. Agilent Application Note, 2004.
- [4] R. Dosoudil, „Determination of permeability from impedance measurement using vector network analyzer,” *Journal of electrical engineering*, vol. 63, No.7, pp. 97-101, Oct. 2012.
- [5] William B. Kuhn, Adam P. Boutz, "Measuring and reporting high quality factors of inductors using vector network analyzers," *IEEE Transactions on Microwave Theory and Techniques*, vol.58, No.4, pp. 1046-1055, Apr. 2010.
- [6] D. Stepins, G. Asmanis, A. Asmanis, "Measuring Capacitor Parameters Using Vector Network Analyzers," *Electronics*, vol.18, no.1, pp.29-38, June 2014.
- [7] C.J. Žlebic, D.R. Kljajic, N.V. Blaž, L.D. Živanov, A.B. Menicanin, and M.S. Damjanovic, "Influence of DC Bias on the Electrical Characteristics of SMD Inductors," *IEEE Transactions on Magnetics*, vol.51, no.1, pp. 1-4, Jan. 2015.
- [8] Keysight Technologies E4990A Impedance Analyzer datasheet.
- [9] Keysight 16047E Test Fixture Operation and Service Manual.
- [10] De-embedding and Embedding S-Parameter Networks Using a Vector Network Analyzer. Agilent application note 1364-1.
- [11] Vector Network Analyzer Family ZVR datasheet. Rohde and Schwarz.