

# Journal of Physics and Its Applications

Journal homepage : <https://ejournal2.undip.ac.id/index.php/jpa/index>



## Repairing and commissioning of an AC motor speed controller for a centrifugal pump

Md. Touhid Nur Rahman<sup>1</sup>, Md. Momin Turzo<sup>2</sup>, A. Masum Billah<sup>3</sup>, Md. Masum Akanda<sup>4</sup>, and Md. Rahat Rahman<sup>5</sup>

<sup>1</sup>Dept. of Mechanical Engineering, RUET, Rajshahi, Bangladesh; Email address: [touhid.ruet10@gmail.com](mailto:touhid.ruet10@gmail.com)

<sup>2</sup>Dept. of Mechanical Engineering, RUET, Rajshahi, Bangladesh; Email address: [mominturzo@gmail.com](mailto:mominturzo@gmail.com)

<sup>3</sup>Dept. of Mechanical Engineering, RUET, Rajshahi, Bangladesh; Email address: [masum122078@gmail.com](mailto:masum122078@gmail.com)

<sup>4</sup>Dept. of Glass & Ceramics Engineering, RUET, Rajshahi, Bangladesh; Email address: [masumruetgce13@gmail.com](mailto:masumruetgce13@gmail.com)

<sup>5</sup>Dept. of Mechanical Engineering, RUET, Rajshahi, Bangladesh; Email address: [rahatrgm29@gmail.com](mailto:rahatrgm29@gmail.com)

### ARTICLE INFO

#### Article history:

Received : 27 April 2019

Accepted : 27 May 2019

Available online : 31 May 2019

#### Keywords:

DC motor

Pump Testing

Mechanical Fault Detection

Fluid Machinery

### ABSTRACT

A centrifugal pump was installed in 1984 in the Fluid Mechanics Laboratory of Mechanical Engineering Department of Rajshahi University of Engineering & Technology. The motor of the centrifugal pump was dc motor and was not working. It could not be commissioned for a long time because of the damaged speed controller. The main shaft (rotor) was also jammed. In this project work, the dc motor was tried to repair. But it could not be run because the specification of the motor and the operating manual was not available. To complete the project successfully, the dc motor was replaced by an ac induction motor. After replacing the motor, the speed of the new motor was controlled by a variable frequency drive (VFD). Using this device, the speed was controlled from 600 rpm to 3000 rpm smoothly. After the replacement, the testing of the centrifugal pump was successfully performed, and the motor was controlled in various speeds. Experiment on the performance test of the centrifugal pump was carried out satisfactorily running the pump in various speeds operated by the VFD.

### 1. Introduction

AC motor is an electric motor driven by an alternating current (AC). The AC motor commonly consists of two basic parts, an outside stationary stator having coils supplied with alternating current to produce a rotating magnetic field and an inside rotor attached to the output shaft producing a second rotating magnetic field. The rotor magnetic field may be produced by permanent magnets, reluctance saliency or DC or AC electrical windings. Less commonly, linear AC motors operate on similar principles as rotating motors but have their stationary and moving parts arranged in a straight-line configuration, producing linear motion instead of rotation [1].

The two main types of AC motors are classified as induction and synchronous. The induction motor (or asynchronous motor) always relies on a small difference in speed between the stator rotating magnetic field and rotor shaft speed called slip to induce rotor current in the rotor AC winding. As a result, the induction motor cannot produce torque near synchronous speed where induction (or slip) is irrelevant or ceases to exist. In contrast, the synchronous motor does not rely on slip – induction for operation and uses either permanent magnets, salient poles (having projected magnetic poles) or an independently excited rotor winding. Basically, motor come in a variety of forms. The speed controller is different for these forms. The speed controller presented here is designed to

drive a three-phase induction motor i.e, VFD. Variable frequency drive (VFD) is a device that is used for controlling the speed of the three-phase induction motor [2].

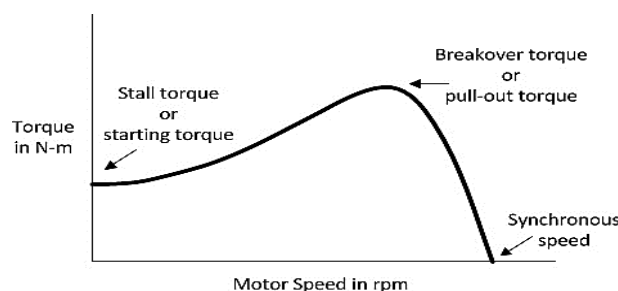

Fig. 1: Torque Vs motor Speed diagram.

The AC induction motor is a workhorse with adjustable speed drive systems. The most popular type is the 3-phase, squirrel-cage AC induction motor. It is a maintenance-free, less noisy and efficient motor. The stator is supplied by a balanced 3-phase AC power source. The synchronous speed  $N_s$  of the motor is calculated by:

$$N_s = \frac{120 f}{P} \dots \dots \dots (1)$$

Where,  $f$  is the synchronous stator frequency in Hz and  $P$  is the number of stator poles. The load torque is produced by slip frequency. The motor speed is characterized by a slip  $S_r$ :

$$S_r = \frac{(N_s - N_r)}{N_s} = \frac{N_{sl}}{N_s} \dots \dots \dots (2)$$

Where,  $N_r$  is the rotor mechanical speed in rpm and  $N_{sl}$  is the slip speed in rpm. From the equation of (1) and (2), the motor speed is controlled by variation of a stator frequency with the influence of the load torque. Figure-1 illustrates the torque characteristics and corresponding motor speed.

### 1.2. Speed Control Method of AC Motor

**Variable Frequency Drive (VFD):** VFD is a power electronics-based device which converts a basic fixed frequency, fixed voltage sine wave power (line power) to a variable frequency, variable output voltage used to control speed of induction motor. It regulates the speed of a three-phase induction motor by controlling the frequency and voltage of the power supplied to the motor.

$$N_s = \frac{120 f}{P}$$

Since the number of poles is constant, the speed ( $N_s$ ) can be varied by changing the frequency. Figure-2 illustrates the internal circuit of a VFD.

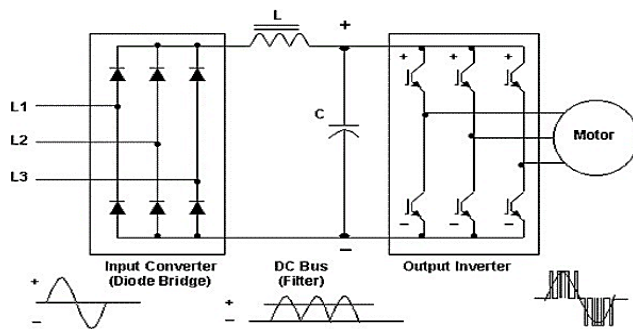

**Fig. 2:** Internal Circuit of Variable Frequency Drive.

Vector control, also called field-oriented control (FOC), is a variable-frequency drive (VFD) control method where the stator currents of a three-phase AC electric motor are identified as two orthogonal components that can be visualized with a vector. One component defines the magnetic flux of the motor, the other the torque. The control system of the drive calculates from the flux and torque references given by the drive's speed control the corresponding current component references [3]. FOC is used to control the AC-synchronous and induction motors [4]. It was originally developed for high-performance motor applications that are required to operate smoothly over the full speed range, generate full torque at zero speed, and have high dynamic performance including fast acceleration and deceleration. However, it is becoming increasingly attractive for lower performance applications as well due to FOC's motor size, cost and power consumption reduction superiority [5, 6]. It is expected that with increasing computational power of the microprocessors it will eventually displace single-variable scalar volts-per-Hertz (V/f) control.

### 1.3. Literature Review

Vector control of AC motors was first successfully applied by two researchers named K. Hasse and S. F. Blaschke under TU Darmstadt's research project in Germany on early 70's [7, 8]. But a fully developed theory had been depicted by W. Leonhard which was experimented in TU Braunschweig's laboratory which was focused on FoC technique and was instrumental for AC-DC drives [9, 10].

Today, this technology has become the standard control method. Vector control is implemented not only in the industrial sector but in many other fields, forming the basis of AC motor control in various motors of differing capacities including induction motors, synchronous motors, and permanent-magnet motors. For example, the world's first inverter air conditioner was developed by Toshiba in 1982 [11], and the introduction of vector-control technology further reduced noise and power consumption. Toshiba also adopted vector-control technology in its elevators and developed the world's first inverter-controlled high-speed gearless elevator in 1983 [12], which simultaneously offered both high speed and comfort. And in the railway sector, vector-control technology allowed the development of the regenerative brake, effective to zero velocity, as well as a function to quickly respond to idle running of wheels. In recent time, G. Mauricio and his team published a conference paper on "Automatic Diagnostic System Oriented Efficiency PUMP Testing System Based on Constant and Variable Speed". In this research, the authors mainly focused on automatic pump testing where the labor and time which is wasted on conventional system can be mitigated [13]. Same as the previous research, M. Hu et al., 2019 published a research article on frequency control of an air conditioning system to control the waste energy, which is beneficial to energy consumption. This research also uses AC-DC conversion methods and FoC terminology [14].

Although it had been considered too early and risky to adopt this technology in 500 kW machine, the drives were used in a paper plant and operated smoothly with the help of elaborate vector-control design and fine tuning. This opened up a new era of AC variable-speed motor drives. Toshiba deployed its microcomputer-based digital controls ahead of other companies, and its AC motor drives were installed in steel plants with capacities of more than 10,000 kW. As a result of Toshiba's innovation, Japan became the world leader in AC variable-speed motor drive technology and DC motors were rapidly replaced by AC motors.

### 2. Methodology

**Faults Finding:** There was a dc shunt motor adjusted with the centrifugal pump. The main target of the project was to control the dc shunt motor in various speed (at least two speed).

**Faults Found:** When the motor was inspected some faults were found which lead to change the dc motor. The faults are -

- i. The speed controller of the dc shunt motor was damaged.

- ii. The shaft of the motor was jammed because of not running for a long time.
- iii. The specification of the dc motor was unknown because there was no specification tag on the motor.
- iv. It was totally impossible to choose speed controller exactly without knowing the specification.
- v. To know the specification, the motor needed to repair.
- vi. At the time of repairing the motor could not be run.

Because of the faults above, it was needed to change the motor. Due to present availability and economic aspects, an AC motor was selected as replacement of the dc motor.

**Removal of Faults:** To remove the faults some decisions were taken, and the faults were removed replacing some parts.

- i. Selection of ac motor: Because of availability and the input main of the Fluid Mechanics Lab, an AC motor was selected. A 3 - phase 2 hp ac induction motor was selected as replacement.
- ii. Adjustment of the shafts: The dc motor was separated from the pump and the ac motor was adjusted with the pump. To adjust, the diameter of the ac motor was decreases by turning process in a lathe machine. Then the shaft of the motor and the shaft of the pump was coupled by a coupling device.
- iii. Extra leg and bearing adjustment: To level the height of the motor to the height of the pump, an extra leg was adjusted with the pump. An extra bearing was added at the adjustment position.
- iv. Frame re-adjustment: To level the height of the motor with the test rig, an extra frame was added with the pump frame.

**Speed Controlling Technique:** An easy way to control the speed of the motor is to control the frequency. So, frequency control method was selected to control the speed of the ac motor. A VFD was bought to control the frequency. The device can control the frequency from 10 Hz to 50 Hz. Controlling the efficiency, the speed of the motor as well as the pump was controlled successfully.

**Frequency - Speed Relation:** The ac motor was consisted of two stator poles. So, from equation (1), the relation between frequency and motor speed becomes,

$$N_s = 60f \dots \dots \dots (3)$$

So, when the frequency is put to 30 Hz, the motor is running at 1800 rpm. By this drive, the motor can be rotate reversely.

**2.1. Mathematical Modeling of the Problem**

(a) **Discharge:** Discharge, Q may be measured by one of the following methods:

- i. By means of a calibrated tank and stop - watch: Dividing the total volume of water collected by the time taken gives the flow rate. i.e,  
 $Q = (\text{Total volume collected})/(\text{Time in second})$

- ii. By means of a venturi meter placed in the delivery pipe:

Discharge can be calculated using the venturi meter from the following equation,

$$Q = C_d A_2 \sqrt{2g \left( \frac{Y_m}{\gamma} \right) H_m / \left\{ 1 - \left( \frac{D_2}{D_1} \right)^4 \right\}} = K \sqrt{H_m} \dots \dots \dots (4)$$

(b) **Head:** Total head H can be measured from the following equation,

$$H = \frac{(P_d - P_s)}{\gamma} + \frac{(V_d^2 - V_s^2)}{2g} + \Delta Z \dots \dots \dots (5)$$

Note that: Here the value of  $\frac{V_d^2 - V_s^2}{2g}$  and  $\Delta Z$  are too small compared to total head. So, they are neglected. Thus, total head, H calculated from,

$$H = \frac{(P_d - P_s)}{\gamma} \dots \dots \dots (6)$$

Which is directly obtained from the manometer reading. The head found from the manometer reading is in mm of Hg which is converted into m of H<sub>2</sub>O.

(c) **Power:**

- i. Input Power: The input power of the motor is found from the following equation,

$$P_i = \frac{PF \times V \times I}{1000} kW \dots \dots \dots (7)$$

Where, PF = 0.85 (Power Factor), V = Input voltage (in Volts), I = Input current (in A).

- ii. Output Power: The output power of the pump is found from the following equation,

$$P_o = \gamma QH \text{ watts} = gQH \text{ kW} \dots \dots \dots (8)$$

Where, Q = Flow rate (in m<sup>3</sup>/sec), H = Total head (in m of water)

(d) **Overall efficiency:** Overall efficiency,

$$\eta = \frac{P_o}{P_i} \dots \dots \dots (9)$$

**2.2. Experimentation**

Performance Test: After all the commissioning and modification, the centrifugal pump was brought to an experiment for checking its performance. For performance test, the rpm value of the motor was changed by varying the frequency or changing the point of knob of the speed controller. Figure-3 and 4 represents the experimental system setup and the speed fixation at different speeds respectively.

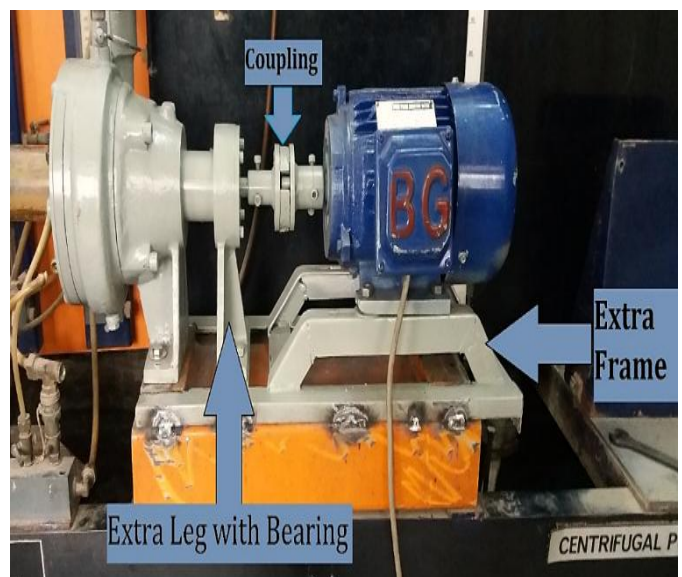

**Fig. 3:** Centrifugal Pump with ac motor after modification



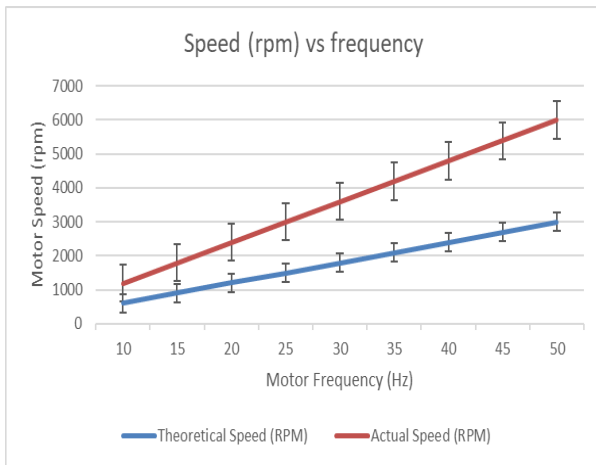

**Fig. 4:** Speed Fixation at Different Speed with respect to driving frequency.

After setting up the motor and the VFD with the Centrifugal Pump Test Rig and removing all faults of the test rig. and measuring instruments, an experiment was performed to see that if the setup was working properly. A pump is a mechanical device for lifting a liquid by creating pressure head. The centrifugal pump is used for very large quantities at low or medium head. Figure 5 shows a typical experimental set - up with centrifugal pump.

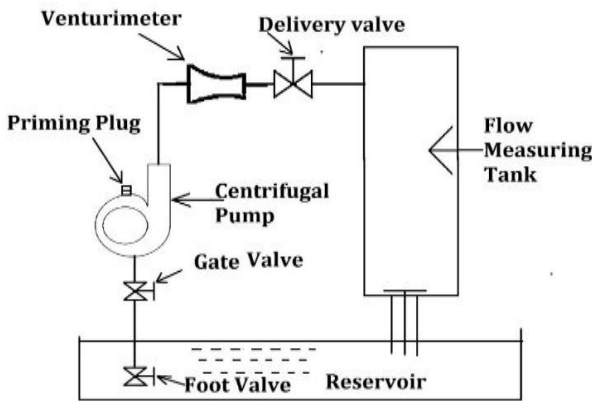

**Fig. 5:** Centrifugal Pump Test Rig.

At first both the suction and delivery valves were fully closed. Priming was done then. After that the VFD was started and then the motor was run with the VFD. Then the suction and delivery valves were fully opened. Then the pump speed was set at maximum value possible using the knob or up key of the VFD. The readings to measure discharge, total head were taken one by one. The value of input current was taken using an ammeter and input voltage was taken using a voltmeter. Then the delivery valve was controlled and steps (vi) and (vii) was repeated several times up to no flow condition. Then the speed of the motor was changed and steps (vi), (vii) and (viii) were repeated at least for four different speeds. All the readings were noted on the experimental data for further calculations.

### 3. Results & Discussions

The results are given below in Table (1) for various speeds and discharges.

**Table 1:** Experimental results for various speeds and discharges.

Speed (rpm)	Total Head (mm of Hg)	Total Head, H (mm of H <sub>2</sub> O)	Volume of H <sub>2</sub> O, V (L)	Time to fill 50L (sec)	Flow rate Q (m <sup>3</sup> /sec)	Input Current, I (Amps)	Input Voltage, V (Volts)	Input Power, P <sub>i</sub> (kW)	Output Power, P <sub>o</sub> (kW)	Efficiency, η (%)
1800	80	1088		55.6	$0.9 \times 10^{-3}$	1.7	285	0.41	0.0096	2.34
	68	924.8		37.9	$1.32 \times 10^{-3}$				0.012	2.93
	70	952	50	34.5	$1.45 \times 10^{-3}$				0.013	3.17
	63	856.8		33.6	$1.49 \times 10^{-3}$				0.013	3.17
2100	60	816		31.4	$1.59 \times 10^{-3}$	2.1	325	0.58	0.013	3.17
	134	1822.4		30.4	$1.66 \times 10^{-3}$				0.030	5.17
	104	1414.4		27.0	$1.85 \times 10^{-3}$				0.026	4.48
	100	1360	50	25.2	$1.98 \times 10^{-3}$				0.026	4.48
2400	90	1224		24.8	$2.01 \times 10^{-3}$	2.7	340	0.78	0.024	4.14
	80	1088		24.1	$2.07 \times 10^{-3}$				0.022	3.79
	189	2570.4		25.4	$1.97 \times 10^{-3}$				0.050	6.41
	135	1836		22.5	$2.22 \times 10^{-3}$				0.040	5.13
2696	124	1686.4	50	21.5	$2.32 \times 10^{-3}$	3.5	360	1.07	0.038	4.87
	110	1496		21.2	$2.36 \times 10^{-3}$				0.035	4.49
	240	3264		21.4	$2.33 \times 10^{-3}$				0.075	7.01
	170	2312		20.7	$2.41 \times 10^{-3}$				0.056	5.23
2997	159	2162.4	50	19.2	$2.60 \times 10^{-3}$	4.5	380	1.45	0.055	5.14
	145	1972		18.8	$2.66 \times 10^{-3}$				0.051	4.77
	135	1836		18.5	$2.70 \times 10^{-3}$				0.049	4.58
	193	2624.8		16.7	$2.99 \times 10^{-3}$				0.077	5.31
2997	168	2284.8	50	15.1	$3.31 \times 10^{-3}$	4.5	380	1.45	0.074	5.10
	160	2176		14.3	$3.50 \times 10^{-3}$				0.075	5.17

From the table of result, the best efficiency was found at 3000 rpm when the discharge was low. For every speed the efficiency was decreasing with the increase of discharge except 1800 rpm.

**Performance Characteristics:** Performance characteristics are very important to measure the efficiency and operation of a pump.

#### i. Operating Characteristic at N = 1800 rpm:

The operating characteristic curve of the centrifugal pump was drawn keeping the speed of the pump constant at 1800 rpm, taking the variation of manometer head and efficiency with respect to discharge. The operating characteristic curve of the pump at 1800 rpm was shown in Figure 6.

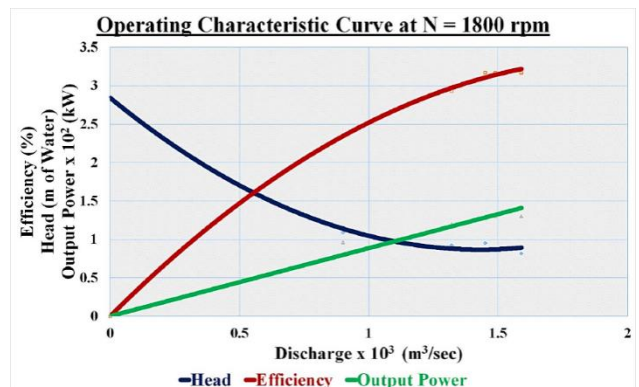
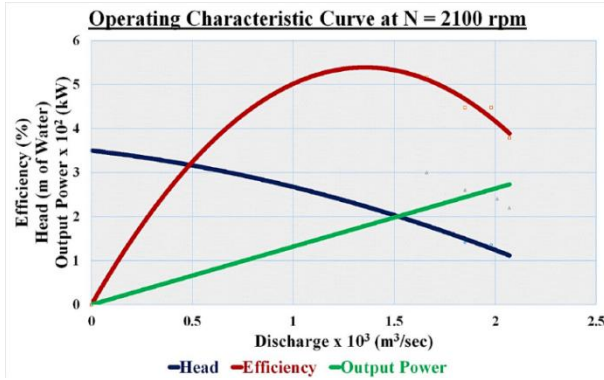

**Fig. 6:** Operating characteristic curve of the centrifugal pump at 1800 rpm.

From the curve, the head was decreasing at first. The head was maximum at zero discharge. But when the discharge was above  $1.2 \times 10^{-3} \text{ m}^3/\text{sec}$ , head changes was very low with the increase in discharge. The efficiency of the pump was increasing first. The

efficiency was zero at zero discharge. But when the discharge was above  $1.4 \times 10^{-3} \text{ m}^3/\text{sec}$ , the efficiency did not change with the increase in discharge.

**ii. Operating Characteristic at N = 2100 rpm:** The operating characteristic curve of the centrifugal pump was drawn keeping the speed of the pump constant at 2100 rpm, taking the variation of manometer head and efficiency with respect to discharge. The operating characteristic curve of the pump at 2100 rpm was shown in Figure 7.



**Fig. 7:** Operating characteristic curve of the centrifugal pump at 2100 rpm.

From the curve, the head was decreasing with the increase in discharge. The efficiency of the pump was increasing first. The efficiency was zero at zero discharge. But after a certain value it was decreasing with the increase in discharge.

**iii. Operating Characteristic at N = 2400 rpm:** The operating characteristic curve of the centrifugal pump was drawn keeping the speed of the pump constant at 2400 rpm, taking the variation of manometer head and efficiency with respect to discharge. The operating characteristic curve of the pump at 2400 rpm was shown in Figure 8.

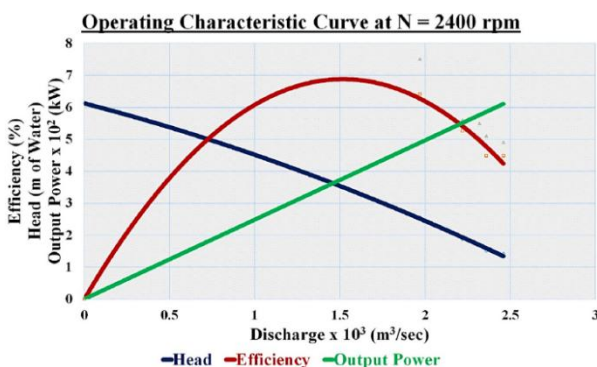
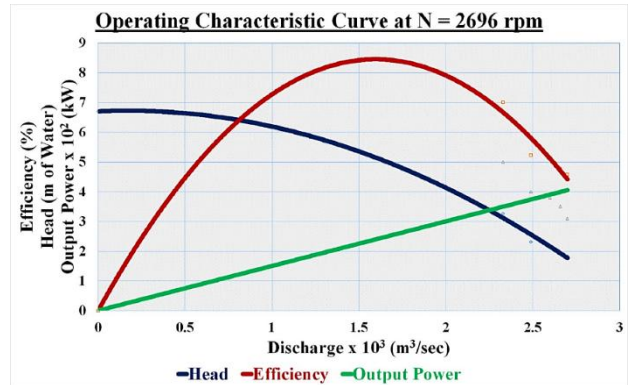

**Fig. 8:** Operating characteristic curve of the centrifugal pump at 2400 rpm.

From the curve, the head was decreasing with the increase in discharge. The head was about 6 m of water when the discharge was zero. The efficiency of the pump was increasing first. The efficiency was zero at zero discharge. But when the discharge was above  $1.5 \times 10^{-3} \text{ m}^3/\text{sec}$ , it was decreasing with the increase in discharge.

**iv. Operating Characteristic at N = 2696 rpm:** The operating characteristic curve of the

centrifugal pump was drawn keeping the speed of the pump constant at 2700 rpm, taking the variation of manometer head and efficiency with respect to discharge. The operating characteristic curve of the pump at 2700 rpm was shown in Figure 9.



**Fig. 9:** Operating characteristic curve of the centrifugal pump at 2700 rpm.

From the curve, the head was decreasing with the increase in discharge. The head was about 6.5m of water when the discharge was zero. The efficiency of the pump was increasing first. The efficiency was zero at zero discharge. But when the discharge was above  $1.5 \times 10^{-3} \text{ m}^3/\text{sec}$ , it was decreasing with the increase in discharge.

**v. Operating Characteristic at N = 2997 rpm:** The operating characteristic curve of the centrifugal pump was drawn keeping the speed of the pump constant at 2997 rpm, taking the variation of manometer head and efficiency with respect to discharge. The operating characteristic curve of the pump at 2997 rpm was shown in Figure 10.

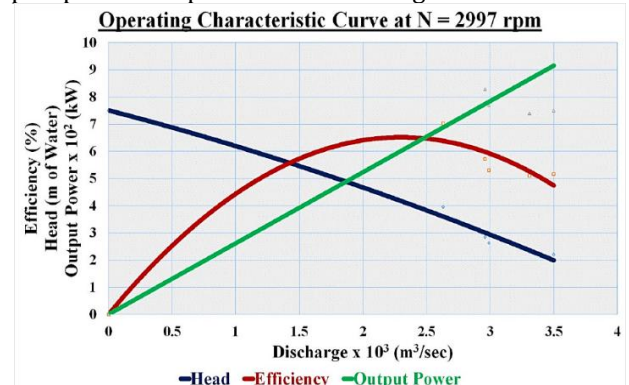

**Fig. 10:** Operating characteristic curve of the centrifugal pump at 2997 rpm.

From the curve, the head was decreasing with the increase in discharge. The head was about 7m of water when the discharge was zero. The efficiency of the pump was increasing first. The efficiency was zero at zero discharge. But when the discharge was above  $2.1 \times 10^{-3} \text{ m}^3/\text{sec}$ , it was decreasing with the increase in discharge.

#### 4. Conclusion

The dc motor of the centrifugal pump was not working, and the shaft of the motor was jammed. So, it was replaced by a three-phase ac motor and the speed of the motor was controlled by a VFD. It was not so easy to couple the shaft of the motor with the

shaft of the pump. But the coupling was done properly and the height of the two devices adjusted very carefully. After adjusting the motor with the pump, the speed of the motor was controlled by controlling the frequency of the input current. By a VFD, the frequency was varied from 10 Hz to 50 Hz. After all the speed controller was working properly and the pump was run in various speed successfully. Due to leakage, the pump could not suck water from the reservoir. But after solving the problems of leakage, it successfully sucked water from the reservoir into outlet tank. Because of not working for a long time, all the measuring instruments of the arrangement were damaged. The damaged devices were repaired for successful reading. After assembling the setup, performance test of the centrifugal pump was done. The experimental results were satisfactory.

### Acknowledgements

This research was conducted under the undergraduate thesis of the first two authors. The authors are very grateful to their supervisor Prof. Dr. Md. Shamim Akhter (Dept. of Mechanical Engineering, RUET, Bangladesh) for his kind affection and support to complete this research. The authors are also thankful to the Dept. of Mechanical Engineering, RUET, Bangladesh for granting necessary helps and supports to conduct this research.

### References

1. Patel, Nimai Charan, Manoj Kumar Debnath, Binod Kumar Sahu, and Pranati Das. "2DOF-PID Controller-Based Load Frequency Control of Linear/Nonlinear Unified Power System." In *International Conference on Intelligent Computing and Applications*, (Springer, Singapore, 2019).
2. Arefin, Md Arman, Avijit Mallik, and Md Asfaquzzaman. "Renewable energy-assisted hybrid three-wheeler: A numerical investigation." *Adv. in Mechanic. Engineering* **10**, (2018).
3. Subotic, Ivan, Obrad Dordevic, Barry Gomm, and Emil Levi. "Active and Reactive Power Sharing Between Three-Phase Winding Sets of a Multiphase Induction Machine." *IEEE Trans. Energy Con.* (2019). (To be published)
4. Nitabaru, Tomoaki, Hiroaki Okada, Toshiaki Isomura, Yoshichika Kawashima, Hideaki Abe, and Hisashi Ogata. *Drive Control Development of Switched Reluctance Motor for Compact Electric Vehicles*. No. 2019-01-0460. SAE Technical Paper, (2019). (To be published)
5. Stekl, P. "3-Phase AC Induction Vector Control Drive with Single Shunt Current Sensing." Czech Republic: Freescale Czech Systems Laboratories (2007).
6. Godbole, Kedar. "Field oriented control reduces motor size, cost and power consumption in industrial applications." Texas Instruments (2006).
7. Murray, Aengus. "Transforming motion: field-oriented control of ac motors-FOC principles simplify the analysis of ac machines and allow good dynamic control of the machine flux and torque." *EDN* **52**, 59 (2007).
8. Rafiq, A., Mohammed Golam Sarwer, Manoj Datta, and B. C. Ghosh. "Fast speed response field-orientation control induction motor drive with adaptive neural integrator." In *2005 IEEE International Conference on Industrial Technology*, 610. IEEE, (2005).
9. Drury, B. "The Control Techniques Drives and Controls: Handbook, EMERSON." (2009).
10. Bose, Bimal K. *Power electronics and motor drives: advances and trends*. Elsevier (2010).
11. Naitoh, Haruo, and Susumu Tadakuma. "Microprocessor-based adjustable-speed dc motor drives using model reference adaptive control." *IEEE Transactions on industry applications* **2**, 313 (1987).
12. Inaba, Hiromi, K. Hirasawa, Takeki Ando, Mitsuyuki Hombu, and M. Nakazato. "Development of a high-speed elevator controlled by current source inverter system with sinusoidal input and output." *IEEE transactions on industry applications* **28**, 893 (1992).
13. Mauricio, Gerson, Christian Ordóñez, Leonardo Vincés, and Julio Ronceros. "Automatic Diagnostic System Oriented Efficiency PUMP Testing System Based on Constant and Variable Speed." In *2018 IEEE Sciences and Humanities International Research Conference (SHIRCON)*, **1**, IEEE, (2018).
14. Hu, Maomao, Fu Xiao, John Bagterp Jørgensen, and Shengwei Wang. "Frequency control of air conditioners in response to real-time dynamic electricity prices in smart grids." *Appl. Energy* **242**, 92 (2019)
15. Islam, Anisul, Md. Mashrur Islam, and Nadim Mahmud. "Stress on spur gear and simulation for micro hybrid systems by Ansys workbench." *J.App. Res. Ind. Eng.* **6**, 80 (2019).