

RIC

# ANALYSIS OF SBR POLYMER ADAPTED TO AN AUTOMOBILE DAMPING SYSTEM

54

## Authors

Adin Gil\*; Antonio Huang; Luz Jiménez; Paul Madrid; Fátima Reyna y Delkis Vergara

## Area

Naval Engineering  
Technological University of Panama

## ABSTRACT

To improve the reliability of the damping system of an automobile we investigated a new design which adds a rubber bushing and spring in parallel with the existing spring. This model provides acceptable stiffness values regarding the car suspension. Simulation shows that this model adds a resistance feature to the dynamic constant changes.

## KEY WORDS

Viscoelastic material, damping system, natural frequency, styrene butadiene

# 1. Introduction

Springs are commonly used as shock absorbers in automotive suspension systems. As with many mechanical elements, their performance decreases with time. If the stiffness decreases, higher frequency oscillations are transmitted to the car body, resulting in degraded comfort and handling performance. Eventually the shock absorber must be replaced [1].

In this paper we present a model for an additional component whose intent is to reduce the stress on the original component thereby extending its usable lifetime. The component which we refer to as TK-40 Poldser uses the elastic polymer Styrene Butadiene Rubber (SBR). The SBR part was designed to maximize the material properties (see figure 1). The geometry of the rubber piece adds value of stiffness and damping coefficients to the system [2 -3].

The added system, TK-40 Poldser is cheaper than the original suspension spare part and its dynamic behaviour is similar to the original spring. We suggest that there would be a cost saving in installing the TK-40 Poldser initially, due to its longer operating lifetime.

## 2. Parameters identification

To compare our design with the original design we chose a Formula SAE racecar model. Table 1 shows the general characteristics of the vehicle.

Tabla1. Parameters for the Formula SAE UPM 08 model [4] and Shock Absorber TTX25MkII [5]

Formula SAE UPM 08			
Parameters	Mass (kg)	Stiffness Coefficient (KN/m)	Damping Coefficient (Kg/s)
Sprung Mass	173	-	-
Unsprung Mass	35	-	-
Wheel	20	127.2	1103

\* Corresponding author:  
adin.gil@utp.ac.pa

Formula SAE UPM 08			
Spring	-	18.709	-
Shock Absorber	-	-	1300

### 2.1 Mechanical Properties and Geometry of the TK-40 Poldser

In Figure 1, it is shown the design of TK-40 Poldser of one piece of SBR polymer. This design was done to maximize the properties of the material and its assembly with the spring. The TK 40 Poldser consists on a spring confined between 2 pieces of “SRB material”.

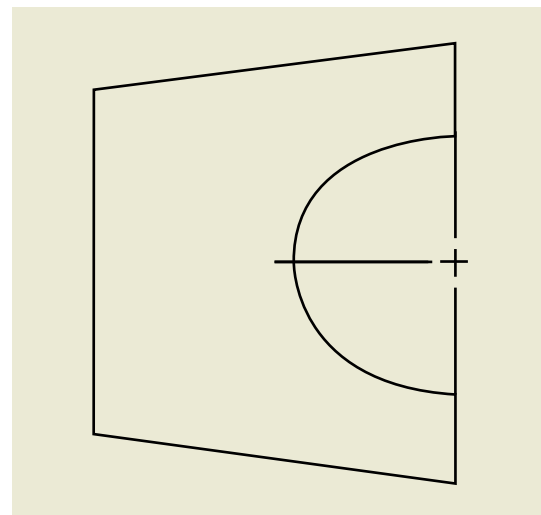

Figure 1. Design of the “SRB” - TK-40 Poldser.

The mechanical properties for both components of the TK-40 Poldser, the spring and the SBR, are shown in table 2.

Table 2. Properties of the spring [6] and SBR [3]

Spring [MATCO17751]	
Stiffness Coefficient (KN/m)	12.7
Styrene-Butadiene rubber [SBR]	
Hardness [IRDH]	50

## 3. Mathematical model

The mechanical properties of SBR are described using a generalized non-linear viscoelastic model [7] [8] which include a non-linear elastic spring, two Maxwell elements, and one friction element.

This model was integrated to the quartercar suspension system model [1] as shown in Figure 2.

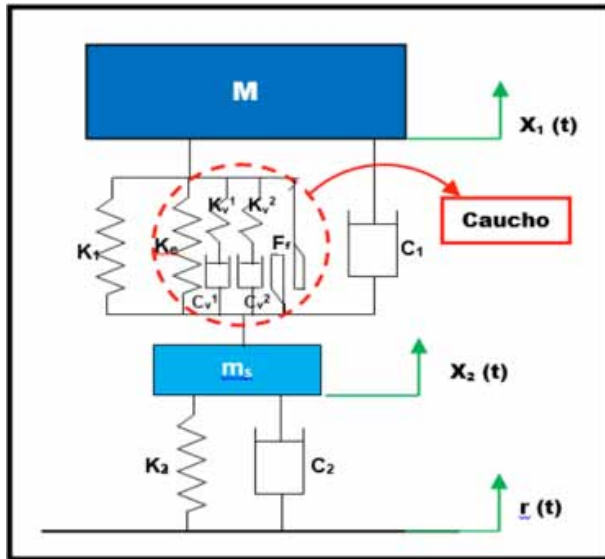

Figure 2. Mathematical Model of a Car Suspension System with integrated TK-40 Polsder.

### 3.1 Equations of the mathematical model

According to Newton's Second Law, the motion of the spring and unprung mass in the car suspension system model is described by the following equations:

$$M\ddot{x}_1 = -K_1(x_1 - x_2) - F_e - F_v - F_f - C_1(\dot{x}_1 - \dot{x}_2) \quad (3.1)$$

$$m_s\ddot{x}_2 = -K_1(x_2 - x_1) - F_e - F_v - F_f - C_1(\dot{x}_2 - \dot{x}_1) - K_2(x_2 - r(t)) - C_2(\dot{x}_2 - \dot{r}(t)) \quad (3.2)$$

Where: M = spring mass. ms = un-sprung mass. K1 =stiffness coefficient of suspension system. K2=stiffness coefficient of wheel and tire. C1=damping coefficient of suspension system. C2=damping coefficient of wheel and tire.

To represent the effect of rubber, the generalized model uses three forces: Fe in the equation 3.3 provides the non-linear spring element; Fv is the complex viscous force which includes a real and an imaginary component [eq. (3.5), eq. (3.6)]; and Ff represents the damping by a friction force eq. (3.3) [8].

$$F_e = \frac{K_e 2d_e}{\pi} \tan \pi x / 2d_e \quad (3.3)$$

$$F_f = \frac{F_{fmax}}{2x_{02}} \left( \sqrt{x_{02}^2 + r_m^2 + 6x_{02} - x_{02} - x} \right) \quad (3.4)$$

$$F_{v0Re} = \left( \frac{(\omega c_{v1})^2}{1 + (\frac{\omega c_{v1}}{K_{v1}})^2} K_{v1}^1 + \frac{(\omega c_{v2})^2}{1 + (\frac{\omega c_{v2}}{K_{v2}})^2} K_{v2}^2 \right) \quad (3.5)$$

$$F_{v0Im} = \left( \frac{c_{v1}}{1 + (\frac{\omega c_{v1}}{K_{v1}})^2} + \frac{c_{v2}}{1 + (\frac{\omega c_{v2}}{K_{v2}})^2} \right) \omega x \quad (3.6)$$

The parameters Ke, Kv1, Kv2 are the stiffness coefficients of the non-linear spring and viscous elements and Cv1, Cv2 are the damping coefficients. Ff max is the maximum friction force and x02 is the displacement required to gain this force [9]. The system is subjected to an exciting force, in this case, the effect of soil surface irregularities. According to the EUSAMA Norm [10] these irregularities can be modeled using a harmonic function, as shown in Eq. 3.7.

$$\dot{r}(t) = r_m \cos \omega t \quad (3.7)$$

## 4. Results

Using the mathematical model specified in the preceding section and the material specifications, we proceed to simulate the system using Matlab, for both the original suspension system and our modified system TK-40 Polsder.

The results from the Matlab simulation of the original system and the TK-40 Polsder system are presented in the first and second graph respectively.

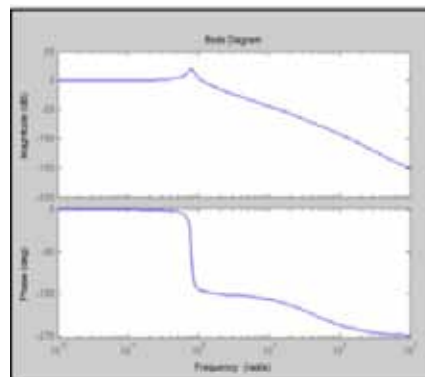

Graphic 1. Bode Plot- Original Suspension System.

The peak in the Magnitude vs Frequency portion of the graph occurs at the transition frequency (Mn). The frequency is independent of the damping coefficient because it depends of the permanent vibration of the disturbing force applied, instead of the speed of the function. The value at the resonance peak represents the maximum value experience by the system in response to the oscillating frequencies. The maximum magnitude depends on the load applied when the frequency increases. The amplitude reaches a maximum value when the excitation frequency is equal to the natural frequency of the system. This will lead to an over damping in the system that can therefore lead to unity gain values of the system. [13].

The second plot shows the results using the TK-40 Po l sder model. The maximum value of the resonance frequency increases by a factor of 0.5 from the original model using a new phase margin between 0 and -90 degrees. Both models were run using similar initial conditions, and both resulted in similar gains as shown the phase angle vs frequency response and the tolerance in system delays. The delay can be an extra block in the forward path of the block diagram that adds phase to the system but has no effect on the gain. The approximations of the system delay using this method is error prompt, since the magnitude depends on the frequency, increasing the magnitude of the error for small frequencies values [14].

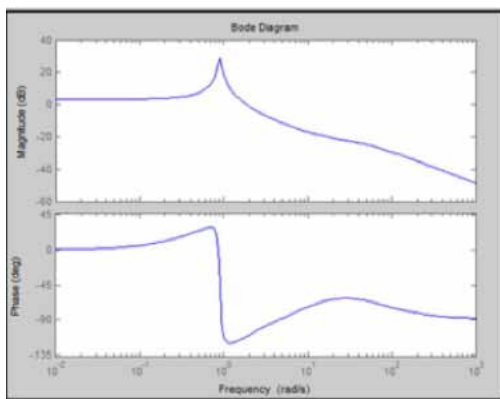

Graphic 2. Bode Plot- Suspension System with integrated TK-40 Polster.

The response at higher frequencies need to be improved for the new design.

## 5. Conclusions

We presented a design, TK-40 Polster that when added to an existing suspension system, improves the system load response vs. frequency at resonance.

The design presented for the “SRB”-Spring lateral sandwich has a simple geometrical form. This analysis is only based on mathematical calculations and the next step is to fabricate the part and submitted it to a rigorous measurements.

## ACKNOWLEDGEMENTS

This work was done under the supervision of Dr. Nacari Marin and the guidance of the Eng. Jorge de La Cruz, to whom we would like to express our sincere gratitude. A special thanks to Dr. Elida De Obaldia for her time and important comments.

## REFERENCES

- [1] Víctor Chacón Hernando, “Diseño de una suspensión para un vehículo automóvil basada en amortiguadores magnetoreológicos”, Undergraduate Thesis, Universidad Carlos III de Madrid, Madrid, 2009.
- [2] Fereshteh Motiee, Saeed Taghvaei-Ganjali and Mercedeh Malekzadeh, “Investigation of correlation between rheological properties of rubber compounds based on natural rubber/styrene-butadiene rubber with their thermal behaviors”, *International Journal of Industrial Chemistry*, 10.1186/2228-5547-4-16, 20132010.
- [3] A. Mujtaba , M. Keller , S. Ilisch , H.-J. Radosch, T. ThurnAlbrecht, K. Saalwächter, and M. Beiner “Mechanical Properties and Cross-Link Density of Styrene-Butadiene Model Composites Containing Fillers with Bimodal Particle Size Distribution”, *Walter-Hülse-Str. 1, 06120 Halle (Saale), Germany*, 2012.
- [4] Fórmula Student, “UPM Racing”, Technical University of Madrid. Proptype: UPM 08. Available on: [www.upmracing.es/formula-student](http://www.upmracing.es/formula-student).
- [5] Öhlins, USA. Review day: June 3, 2015. Available on: [www.ohlinsusa.com/ohlins-ttx-25-fsae](http://www.ohlinsusa.com/ohlins-ttx-25-fsae).
- [6] General Motors, “Fuelle de Dirección”, MAPCO 17751, 90090811.
- [7] Fredrik Karlsson and Anders Persson, “Modelling nonlinear dynamics of rubber bushings-Parameters Identification and Validation”, Master Dissertation, Lund University, Division of Structural Mechanics, Sweden, 2003.
- [8] A.K. Olsson and P-E Austrell, “A fitting Procedure for viscoelasticelastoplastic Material Models”, *Proceedings of The Second European Conference on Constitutive Models for Rubber*, Germany, 200.
- [9] Zhang Lijun, Yu Zengliang and Yu Zhuoping, “Novel Empirical Model Of Rubber Bushing in Automotive Sus-pension System”, College of Automotive Engineering, Tongji University Cao`an road, 4800, 201804, Shangai, China.
- [10] C. Bocheński, Z. Lozia, J. Mikołajczuk, “Test of objective evaluation of build in vehicle shock absorber research method recommended by EUSAMA association”, *Diagnostyka Maszyn Roboczych*, Borówno, 1999.
- [11] National Emission Standards for Hazardous Air Pollutants: “Rubber Tire Manufacturing – Final Rule”, *Federal Register*. 40 CFR Part 63. Vol. 67, No. 161, 2002. pp. 45588.
- [12] “Development of Emission Factors for the Rubber Manu-facturing Industry”, Volume 4: Emission Factor Application Manual. Final Report, prepared for the Rubber Manufacturers Association (RMA) by TRC Environmental Corporation, Lowell, MA, 1995.
- [13] J.D. Ulmer, “Strain Dependence of Dynamic Mechanical Properties of Carbon-Black-Filled Rubber Compounds, *Rubber Chemistry and Technology*, Vol. 69.
- [14] S. Vieweg ET. AL, “Frecuency and Temperature Depend-ence on the Small-Strain Behavior of CarbonBlack-Filled Vulcanizates, Polym”, *Networks Blends*, 1995.