



BearWorks

[MSU Graduate Theses](#)

Spring 2017

The Effect of Rate on Tone Burst Extratympanic Electrocochleography in Adults with Normal Hearing

Alana E. Kennedy

Missouri State University, Kennedy00@live.missouristate.edu

As with any intellectual project, the content and views expressed in this thesis may be considered objectionable by some readers. However, this student-scholar's work has been judged to have academic value by the student's thesis committee members trained in the discipline. The content and views expressed in this thesis are those of the student-scholar and are not endorsed by Missouri State University, its Graduate College, or its employees.

Follow this and additional works at: <https://bearworks.missouristate.edu/theses>

 Part of the [Communication Sciences and Disorders Commons](#)

Recommended Citation

Kennedy, Alana E., "The Effect of Rate on Tone Burst Extratympanic Electrocochleography in Adults with Normal Hearing" (2017). *MSU Graduate Theses*. 3068.

<https://bearworks.missouristate.edu/theses/3068>

This article or document was made available through BearWorks, the institutional repository of Missouri State University. The work contained in it may be protected by copyright and require permission of the copyright holder for reuse or redistribution.

For more information, please contact [BearWorks@library.missouristate.edu](mailto: BearWorks@library.missouristate.edu).

**THE EFFECT OF RATE ON TONE BURST EXTRATYMPANIC
ELECTROCOCHLEOGRAPHY IN ADULTS WITH NORMAL HEARING**

A Doctoral Thesis

Presented to

The Graduate College of
Missouri State University

In Partial Fulfillment

Of the Requirements for the Degree

Doctor of Audiology

By

Alana Elizabeth Kennedy

May 2017

Copyright 2017 by Alana Elizabeth Kennedy

**THE EFFECT OF RATE ON TONE BURST EXTRATYMPANIC
ELECTROCOCHLEOGRAPHY IN ADULTS WITH NORMAL HEARING**

Communication Sciences and Disorders

Missouri State University, May 2017

Doctor of Audiology

Alana Elizabeth Kennedy

ABSTRACT

The recording of electrocochleography (ECoChG) to tone burst stimuli with a high rate is hypothesized to provide advantages over standard click ECoChG with slow rate. Specifically, the use of tone burst stimuli presented at a high rate may enhance the summing potential (SP) while also reducing neural contributions in the response. To allow for the analysis of the complex ECoChG responses to high rates, the Continuous Loop Averaging Deconvolution (CLAD) technique was employed to deconvolve the responses. This study examined the effect of high rate and stimulus duration on the SP amplitude of tone burst extratympanic ECoChG in 20 adult females with normal hearing. ECoChG was recorded using 500 Hz and 2000 Hz stimuli with varied durations (12 ms, 6 ms, 3 ms) and five rates ranging from 7.1/s to 234.38/s. Within-subject repeated measures (rate x duration) analysis of variance were conducted. For both 500 Hz and 2000 Hz, the mean deconvolved SP amplitudes were larger at faster rates compared to slower rates, and larger at shorter duration than longer duration. With the long durations, the increase in SP amplitude with high rate is thought to be due to changes in cochlear mechanics and nonlinearity of the inner hair cells. However, the large amplitude measured in the short duration conditions is mostly due to the contribution of the action potential in the recording. Our study supports the use of the CLAD technique with tone burst ECoChG and provides normative data upon which further research can build.

KEYWORDS: electrocochleography, tone burst, summing potential, high repetition rate, Continuous Loop Averaging Deconvolution

This abstract is approved as to form and content

Wafaa Kaf, Ph.D.
Chairperson, Advisory Committee
Missouri State University

**THE EFFECT OF RATE ON TONE BURST EXTRATYMPANIC
ELECTROCOCHLEOGRAPHY IN ADULTS WITH NORMAL HEARING**

By

Alana Elizabeth Kennedy

A Doctoral Thesis
Submitted to the Graduate College
Of Missouri State University
In Partial Fulfillment of the Requirements
For the Degree of Doctor of Audiology

May 2017

Approved:

Wafaa Kaf, PhD

Rafael Delgado, PhD

John Ferraro, PhD

Jeffery Lichtenhan, PhD

Julie Masterson, PhD: Dean, Graduate College

ACKNOWLEDGEMENTS

Thank you to Jake Flaten, my parents, Cheryl and John Kennedy, and all my friends and family for their constant support and encouragement during the course of the research. I'd also like to thank my research advisor, Dr. Wafaa Kaf, who provided exceptional guidance throughout this process. I am so thankful to have had the opportunity to learn from Dr. Kaf and know that her mentorship has helped me to grow as a student, researcher, and future professional. Thank you to my committee members, Dr. Jeffery Lichtenhan, Dr. John Ferraro, and Dr. Rafael Delgado, for their time and contributions to this research. Lastly, I'd like to thank the Missouri State University Graduate College, the Department of Communication Sciences and Disorder, and all those who participated in the study, for without their assistance this research would not have been possible.

TABLE OF CONTENTS

Introduction.....	1
Literature Review.....	6
Electrocochleography	6
Electrocochleography in Ménière’s Disease.....	10
High Repetition Rate Using Continuous Loop Averaging Deconvolution with Electrocochleography	24
Objective.....	26
Methods.....	28
Participants.....	28
Equipment.....	29
Stimulus and Recording Parameters	30
Procedures.....	34
Data Analysis	36
Results	40
SP Amplitude Data as a Function of Stimulus Rate and Duration	40
TM Electrode Placement and Audiometric Threshold	50
Discussion.....	54
SP Amplitude Data	55
High Repetition Rate and Continuous Loop Averaging Deconvolution	66
Audiometric Threshold Data.....	66
Limitations of the Study.....	69
Future Studies	70
Conclusion	72
References.....	75

LIST OF TABLES

Table 1. Stimulus and recording parameters for the ECoChG measurements.	32
Table 2. Mean SP amplitudes for 500 Hz and 2000 Hz.....	46
Table 3. Hearing threshold values.	52

LIST OF FIGURES

Figure 1. Ipsilateral electrode montage.....	30
Figure 2. 500 Hz loopback recording	33
Figure 3. Labeling used for 500 Hz SP recordings.....	37
Figure 4. Labeling used for 2000 Hz SP recordings.....	38
Figure 5. Standard click ECoChG	40
Figure 6. 500 Hz non-deconvolved ECoChG.....	42
Figure 7. 2000 Hz non-deconvolved ECoChG.....	43
Figure 8. 500 Hz CLAD deconvolved ECoChG	44
Figure 9. 2000 Hz CLAD deconvolved ECoChG.	45
Figure 10. Mean SP amplitude across rate.....	47
Figure 11. Mean SP amplitude across duration	47
Figure 12. 500 Hz mean SP amplitude across rate and duration	49
Figure 13. 2000 Hz mean SP amplitude across rate and duration	51
Figure 14. Audiometric threshold for each test condition across frequency	53
Figure 15. Spectral filtering.....	60

INTRODUCTION

Electrocochleography (ECoChG) has been well established as a tool for examining the electrophysiological properties of the early components of the auditory pathway, including the cochlea and the auditory nerve. ECoChG allows for an objective assessment of these structures. The application of ECoChG for both clinical and research purposes is extensive, and while it is used to assess a wide variety of auditory pathology, its use as a diagnostic tool for Ménière's disease is well documented throughout the literature (Ferraro & Durrant, 2006). While specific criteria have been established, such as the use of the summing potential (SP)/action potential (AP) amplitude ratio, to determine the presence or absence of Ménière's disease, the relatively low sensitivity of this measure alone has limited its diagnostic value (Al-momani, Ferraro, Gajewski, & Ator, 2009; Ferraro & Durrant, 2006; Ferraro & Tibbils, 1999). The lack of sensitivity of the SP/AP amplitude ratio measurements obtained from standard click ECoChG and the pathophysiology of the disease has led to the continued evaluation of ECoChG procedures and parameters in the attempt to develop a test protocol sensitive to the pathological effects of Ménière's disease.

One such method has been the use of frequency specific, tone burst stimuli in ECoChG recordings which allows for the assessment of the SP across frequencies. As Ménière's disease typically presents with fluctuating hearing loss, initially affecting the low frequencies, the ability to assess auditory potentials from sites along the cochlea using low frequency stimuli may allow for further insight into the disease. Both the AP, derived from the auditory nerve, and the SP, a cochlear potential thought to be generated

mainly by the inner hair cells, are affected by the use of tone burst stimuli (Durrant, Wang, Ding, & Salvi, 1998). The AP has been shown to vary greatly depending upon the eliciting frequency, and is often obscured by the SP, which under ideal circumstances could last for the duration of the stimulus envelope (Ferraro, Blackwell, Mediavilla, & Thedinger, 1994a; Mouney, Cullen, Gondra, & Berlin, 1976). As a result, in the study of tone burst ECoChG, the potential usefulness of the SP, specifically the SP amplitude, has been the primary focus.

Gibson (1993) was one of the first to develop criteria for the use of tone burst transtympanic (TT) ECoChG in the examination of Ménière's disease by evaluating the SP amplitude. Gibson (1993) determined that the most effective frequencies when evaluating the disorder were 500 Hz and 1000 Hz, while 4000 Hz was the least effective. Gibson (2009) repeated the study with matched hearing loss controls (ears without Ménière's disease, but with sensorineural hearing loss) and found that 500 Hz, 1000 Hz, and 2000 Hz were most sensitive, while significant overlap in responses between groups occurred at 4000 Hz and 8000 Hz. Gibson (1993; 2009) also compared the results to click stimuli SP/AP amplitude ratio measurements, and determined the use of tone burst SP amplitude was a sensitive measure to Ménière's disease. Others have found increased sensitivity with SP amplitudes obtained from 1000 Hz tone burst stimuli with the use TT ECoChG when compared to click evoked SP/AP amplitude ratios (Conlon & Gibson, 2000; Iseli & Gibson, 2010). These findings support the use of frequency specific stimuli in ECoChG measures when examining the effects of Ménière's disease.

At present time, the majority of tone burst ECoChG studies have used relatively long stimulus durations (≥ 12 ms) in the examination of the SP. While this approach

allows for clear observation of the SP, it limits the repetition rate at which tone burst stimuli can be presented without overlap of the signal. As such, repetition rate, a potentially significant factor in the collection of tone burst ECoChG, is limited. Wuyts et al. (2001) examined the effect of rate on the SP amplitude in TT ECoChG using 1000 Hz tone burst stimuli in subjects with Ménière's disease and subjects without the disease. Rate was varied between 8.4-37.4 tone bursts/second and revealed that SP amplitude increased with increased rate, regardless of the presence or absence of the disease, with larger SP amplitude found in those with the disease (Wuyts et al., 2001). It is hypothesized that increased repetition rate causes a non-linearity on the basilar membrane, as it has not returned to its original position before the onset of the next stimulus, which influences the recorded SP amplitude (Wuyts et al., 2001). While Wuyts et al.'s (2001) studied examined increased repetition rate using TT ECoChG, there is limited research focused the use of extratympanic (ET) recording of tone burst ECoChG with increasing and high repetition rates above 37 tone bursts/second.

As waveforms recorded using high rates are significantly degraded and impossible to interpret using the standard measure analysis technique, ECoChG to very high repetition rates requires a special technique to help analyze the complex, overlapped waveforms (Delgado & Ozdamar, 2004). This complex waveform occurs as the response from one eliciting stimulus has not ended before the presentation of the next, creating overlap within the acquired waveform. Recently, a new technique, continuous loop averaging deconvolution (CLAD), has been designed to employ algorithmic formulas to deconvolve or "unwrap" waveforms collected at very high rates. The use of CLAD to deconvolve electrocochleograms obtained with high repetition rates has been utilized

successfully in the literature. Kaf, Lewis, Yavuz, Dixon, van Ess, Jamos, and Delgado (2017) presented normative ET click ECoChG and ABR data at a rate up to 507 clicks/s using this novel technique. The CLAD technique has also shown promise in the assessment of Ménière's disease through the use of high, 800 clicks/s, rate TT ECoChG and ABR measures (Bohorquez, Ozdamar, McNeer, & Morawski, 2009).

The use of ET recording sites requires the placement of a small electrode on the surface of the tympanic membrane (TM). It is hypothesized that this placement may affect the transmission characteristics of the middle ear due to pressure of the electrode resting on the TM. Though an early evaluation of TM electrodes by Stypulkowski and Staller (1987) recorded the thresholds of a small group of subjects ($n = 3$) prior to and with the placement of the electrode on the TM recording found no significant changes in audiometric threshold with electrode placement. A recent study by Smith, Lichtenhan, and Cone (2016) demonstrated audiometric shift with the placement of the electrodes. The authors reported that significant air conduction pure tone threshold shifts from baseline were found on average to be 7.5 dB at 250 Hz, 4.2 dB at 500 Hz, and 3.89 dB at 8000 Hz (Smith et al., 2016). As TM electrodes are commonly used during the recording of ECoChG, this research is valuable in better understanding the potential effects during the transduction of signals, especially when low frequency tone bursts are being used to elicit a response.

The present study was designed to investigate the effects of high rate and stimulus duration on SP amplitude of 500 Hz and 2000 Hz tone burst ECoChG in adults with normal hearing. This research is the first step in understanding the physiological effect of high rate on tone burst ECoChG in subjects without a history of inner ear pathology, and

in establishing normative SP amplitude data upon which further research can build. The goals of this study include (1) establishing normative SP amplitude data for high rate tone burst ECoChG at 500 Hz and 2000 Hz, (2) examining the effect of stimulus duration on tone burst ECoChG for slow and high repetition rate, and 3) examining the effect of TM electrode placement on audiometric thresholds.

LITERATURE REVIEW

Electrocochleography

Electrocochleography (ECoChG) is a useful measure in the both the far and near-field recording of the cochlear and auditory nerve potentials to auditory stimulation. Cochlear potentials evaluated include the cochlear microphonics (CM), and summing potential (SP), while the action potential (AP) is recorded from the auditory nerve. These electrophysiological recordings can be made using several different electrode placements, including a TT method in which a needle electrode is passed through the TM and placed on the promontory near the round window, and an ET measure where an electrode is placed on the TM or in the ear canal (Ferraro, 2010). ECoChG has been routinely evaluated in both normal hearing individuals and those with auditory pathologies, and is a commonly used tool in the evaluation of Ménière's disease.

Early Auditory Evoked Potentials. The cochlear microphonic is an alternating current response which represents the summation of outer hair cell potentials as the basilar membrane vibrates in response to sound (Ferraro & Durrant, 2006). The cochlear microphonic is influenced by the site of recording and the acoustic stimulus used to elicit the response. TT recordings on the round window and ET recordings from TM or ear canal, are thought to primarily represent the outer hair cell activity of the basal portion of the cochlea, as this region is nearest the recording site and the hair cells are responding in phase, enhancing the cochlear microphonic (Ferraro, Best, & Arenberg, 1983). As recordings from these sites are most commonly used clinically, the presence of a cochlear microphonic does not necessarily mean the absence of cochlear pathology, as the apical

portion of the cochlea is contributing little to the recording. The cochlear microphonic also mirrors the auditory stimulus from which it was evoked; a feature which may lead to difficulty distinguishing the recorded cochlear microphonic from stimulus artifact (Ferraro, 2010; Ferraro & Durrant, 2006). The cochlear microphonic has been widely researched, but the exact mechanisms behind its production remain unknown (Ferraro & Durrant, 2006). The limitations associated with the recording of this potential as well as little research to demonstrate its benefit in the evaluation of Ménière's disease and endolymphatic hydrops, limits the usefulness of the cochlear microphonic in the examination of this disease (Ferraro & Durrant, 2006; Ferraro et al., 1983) though it is often examined in relation to other processes or pathologies.

In contrast to the cochlear microphonic and AP, the SP is a direct current potential. Similar to the cochlear microphonic, the SP is also dependent on the eliciting stimulus, as the SP will last approximately duration of the stimulus waveform (Ferraro & Durrant, 2006). The SP also likely reflects the non-linearity of hair cells along the basilar membrane in response to acoustic stimuli and is thought to represent the electric resistance generated as the basilar membrane moves (Abramovich, 2013; Wuyts et al., 2001). It is likely that the both the outer and inner hair cells contribute to the generation of the SP, with inner hair cells contributing to a larger portion of the response (Durrant et al., 1998). Through selective destruction of the inner hair cells and outer hair cells in chinchillas, Durrant et al. (1998) were able to separate the contributions of the hair cells to the production of the SP at multiple intensity levels. In the condition where inner hair cell damage was extensive and outer hair cell damage was minimal, a SP could still be recorded from the round window, though its overall amplitude was reduced significantly

(Durrant et al., 1998). Durrant et al. (1998) reported that at low and moderate intensities, the inner hair cells contribute to approximately 70% of the SP amplitude, but only 50% at higher intensities. However, there is still much debate over the generation sites of the SP and the role of the SP in the ability to hear is still unknown (Ferraro & Durrant, 2006).

The AP is generated from synchronous firing of the distal portion of the auditory nerve. Often, the AP is referred to as the compound action potential (CAP) as clinically the stimuli used to elicit the potential, whether click or tone burst, produce synchronous firing along certain portions of the cochlea (Ferraro & Durrant, 2006). Because the AP is dependent upon the synchronous firing of nerves, click and tone burst stimuli with short onsets are commonly used to assess this response. The AP is an alternating current potential, and in ECoChG the first peak of the action potential, typically labeled N1, corresponds to wave I of the auditory brainstem response (Ferraro & Durrant, 2006).

Transtympanic versus Extratympanic Recordings. In general, there are two different types of ECoChG recording methods, TT and ET. TT ECoChG is an invasive method in which a needle electrode is placed on the promontory of the cochlea via the TM (Ferraro & Durrant, 2006). Due to its invasive nature, it has not been favored throughout the United States, but is used rather prevalently in other countries (Ferraro & Durrant, 2006; Ferraro & Tibbils, 1999). ET recording is less invasive and consists of an electrode placed either directly on the TM, or in the ear canal (Ferraro & Durrant, 2006). Studies comparing the two recording methods, report appreciable differences between the two procedures, though both can be used successfully in ECoChG evaluations (Ferraro & Durrant, 2006). Haapaniemi, Laurikainen, Johansson, and Karjalainen (2000) evaluated the use of ET and TT ECoChG simultaneously and determined waveform morphology

and latency measures to click stimuli were comparable between the two methods; however the TT electrode placement offered a SP amplitude 3.6-5.1 times larger and an AP amplitude 5.3-6.4 times larger than the ET recordings. Schoonhoven, Fabius, and Grote (1995) found similar results when evaluating the difference between simultaneous ET and TT recordings to short duration tone burst stimuli; they reported no difference in latency, but again an increase in the AP amplitude with the use of TT recording measures. While, TT measures are advantageous in producing responses which are larger in amplitude as well as more reliable and sensitive, their invasive nature, the need for physician oversight, a medical setting, and local anesthetics are all factors which often limit their clinical utility (Ferraro & Durrant, 2006; Ferraro, Thedinger, Mediavilla, & Blackwell, 1994b). ET recordings are often considered useful due to their non-invasive nature and ability to be performed successful outside of a medical environment and as long as signal averaging is appropriate, results comparable to TT measures can be obtained (Ferraro & Durrant, 2006; Schoonhoven et al., 1995).

Recently, Smith et al. (2016) investigated possible shift in hearing sensitivity with use of ET electrodes placed on the TM. The authors reported that significant air conduction pure tone threshold shifts were, on average, 7.5 dB at 250 Hz, 4.2 dB at 500 Hz, and 3.89 dB at 8000 Hz, compared to 0-1 dB change noted for the same frequencies in the control group who did not receive TM electrode. Though neither bone conduction testing nor retest following electrode removal was performed in order to establish the conductive nature of the change, it is suspected that the TM electrode placement reduced the transmission of the low frequency tones through the middle ear (Smith et al., 2016). In the evaluation of TM and TT electrodes, Stypulkowski and Staller (1987) recorded the

thresholds of a small group of subjects ($n = 3$) prior to and with the placement of the electrode on the TM. No changes in audiometric threshold were reported with electrode placement, although the authors suspected that the electrode placement on the TM would primarily affect low frequency hearing (Stypulkowski & Staller, 1987). The effect of TM electrode placement on the collection of ECoChG potentials, the SP and AP, including SP/AP amplitude and area ratios has also been evaluated (Alhanada, 2012). The location of the electrode on the TM was assessed across multiple test sessions on the same normal hearing subjects in order to determine the effect of TM electrode placement on the recording with all ECoChG parameters remaining constant (Alhanada, 2012). No clinically relevant variations on the electrocochleogram were found when the location of the TM electrode was assessed (Alhanada, 2012). As TM electrodes are commonly used during the recording of ECoChG, this research is valuable in better understanding the potential effects during the transduction of signals, especially when low frequency tone bursts are being used to elicit a response.

Electrocochleography in Ménière's Disease

The use of ECoChG in determining the presence or absence of endolymphatic hydrops and more specifically Ménière's disease has been widely researched. A variety of protocols and parameters have been developed in the attempts to solidify ECoChG as a diagnostic measure that is both sensitive and specific to the disorder. This section will discuss Ménière's disease and present the findings of ECoChG to click and tone burst stimuli in patients with Ménière's disease, including the limitations of both measures which highlight the need for further development of ECoChG protocols for the

assessment of the disease. Specifically, the potential utility of high repetition rate, low frequency tone burst ECochG will be examined.

Ménière's Disease. Ménière's disease is a condition affecting the auditory and vestibular structures of the inner ear. The onset of Ménière's disease is most commonly reported between the ages of 40 and 60 and has prevalence of approximately 43 per 100,000 individuals (Sajjadi & Paparella, 2008). Though named over 150 years ago, the exact pathophysiology underlying the condition, diagnostic procedures, and treatment options remain unclear. It is a chronic illness which is characterized by cochlear and vestibular symptoms including fluctuating hearing loss, aural fullness, tinnitus, and episodic vertigo, which often cause great distress to the individual living with the disease.

The underlying pathology likely responsible for Ménière's disease is endolymphatic hydrops, which develops due to the over production or improper reabsorption of endolymph, leading to increased pressure within the cochlea, vestibule, and semicircular canals (Huppert, Strupp, & Brandt, 2010; Hornibrook, Coates, Goh, Gourley, & Bird, 2012; Sajjadi & Paparella, 2008). The etiology of endolymphatic hydrops varies and may come as a result of trauma, autoimmune or inflammatory disorders; it may also be idiopathic or hereditary in nature (Huppert et al., 2010; Sajjadi & Paparella, 2008). While endolymphatic hydrops is believed to be the underlying pathophysiologic correlate to Ménière's disease, it does not necessarily lead to each hallmark characteristic of the disorder, and may not present in a way that establishes the diagnosis of Ménière's disease (Committee on Hearing and Equilibrium, 1995). As such, diagnostic criteria have been created to define Ménière's disease.

According to the American Academy of Otolaryngology – Head and Neck Surgery (Committee on Hearing and Equilibrium, 1995), the diagnosis of definite Ménière’s disease is met with at least two episodes of spontaneous vertigo lasting at a minimum of 20 minutes, an audiological evaluation which documented hearing loss at least once, tinnitus or aural fullness in the suspected pathological ear, and the exclusion of other potential causes. An otolaryngologist may also diagnose an individual with probable or possible Ménière’s disease when symptoms do not exactly match the above criteria. A diagnosis of probable Ménière’s disease is made when all other criteria have been met but only one episode of vertigo has been reported; where possible Ménière’s disease is suggested when hearing loss has either not been documented but the patient experiences vertiginous episodes, or when patient experiences fluctuating hearing loss, but no associated vertigo (Committee on Hearing and Equilibrium, 1995). From the established criteria, it is clear that patient report of symptoms is heavily relied upon in the diagnosis of the disease. In fact a certain diagnosis of Ménière’s disease is only made upon the histopathological confirmation of the presence of endolymphatic hydrops (Committee on Hearing and Equilibrium, 1995). This reliance on patient report underlies the reason for the continued pursuit of sensitive and specific objective measures in determining the presence of endolymphatic hydrops as well as to differentiate between Ménière’s disease and disorders with similar presenting symptoms.

Click Electrocochleography. Click evoked ECochG has been widely examined as an objective measure for the diagnosis of Ménière’s disease. The CM, SP, and AP have all been evaluated for their potential use as diagnostic indicators of the disease.

SP/AP Amplitude Ratio. It is now well established that an ear with endolymphatic hydrops will often result in an elevated SP amplitude when compared to that of the AP. While the exact mechanism behind this difference remains unknown, it has been suggested that the SP is sensitive to the increased endolymphatic pressure and subsequent distortion of the traveling wave in the cochlea (Ferraro & Durrant, 2006; Ferraro & Tibbils, 1999). The increased calcium content in the endolymph of hydropic inner ears may also account for the change in the SP as its increased concentration is thought to affect the transduction characteristics of the hair cells (Salt & Plontke, 2010). Due to the enlarged SP amplitude to the presence of endolymphatic hydrops, many researchers have assessed the SP/AP amplitude ratio to click stimuli and its diagnostic potential in separating abnormal and normal ears (Levine, Margolis, Fournier, & Winzenburg, 1992; Margolis, Ricks, Fournier, & Levine, 1995; Sass, 1998). The popularity of the SP/AP amplitude ratio is underlined by the variable amplitude of each potential individually. The use of both measures in ratio form increases the sensitivity of the procedure when compared to the examination of the single SP or AP amplitude in normal hearing individuals and those with Ménière's disease (Ferraro et al., 1983). Unfortunately, the SP/AP amplitude ratio alone has been reported to have limited value in diagnosing cases of Ménière's disease, with sensitivity ranging from 55-65% (Al-momani et al., 2009; Ferraro & Durrant, 2006; Ferraro & Tibbils, 1999). The SP/AP amplitude ratio test-retest reliability has also found to be low when compared to other ECoChG measures such as SP amplitude to tone burst stimuli and AP latency values (Levine et al., 1992; Margolis et al., 1995). Sass (1998) reported a sensitivity of click SP/AP amplitude ratio as 62%, with a specificity of 95%. However, when combined with an additional indicator, the SP

amplitude to 1000 Hz tone burst stimuli, sensitivity rose to 82% (Sass, 1998). As such, researchers have proposed alternative or additional measures to the SP/AP amplitude ratio in order to better evaluate endolymphatic hydrops.

SP/AP Area Ratio. Ferraro and Tibbils (1999), assessed the potential value of the SP/AP area ratio in the identification of endolymphatic hydrops. It was proposed that the presence of endolymphatic hydrops effects not only the amplitude of the SP, but also its duration, and as such the area ratio between the SP/AP should be larger than when compared to a healthy ear (Ferraro & Tibbils, 1999). In a comparison of three groups, individuals without hearing loss, individuals with definite Ménière's disease with an elevated SP/AP amplitude ratio, and individuals with probable Ménière's disease with a normal SP/AP amplitude ratio, Ferraro and Tibbils (1999) found that area ratios were elevated in the majority of cases of definite Ménière's disease and elevated in just under half the cases of probable Ménière's disease. Based on these findings, Ferraro and Tibbils (1999) suggest that the addition of SP/AP area ratio to ECoChG measurements, may increase the sensitivity of the test. Al-momani et al. (2009) reported similar findings when assessing the sensitivity of ECoChG to Ménière's disease using a battery of measurements, including area ratio, which was shown to be one of the most sensitive indicators to the presence of Ménière's disease. However, as was the case with the SP/AP amplitude measure, the SP/AP area ratio alone does not provide enough sensitivity to confidently diagnose the disorder. Baba et al. (2009), compared the diagnostic sensitivity of SP/AP amplitude ratio to the SP/AP area ratio and found that in patients with a definite Ménière's disease diagnosis, the SP/AP amplitude ratio was more sensitive (57.1%) than

the SP/AP area ratio (43.9%). This again highlights the need for continued examination of these and other ECochG protocols in improving the clinical utility of the measure.

Action Potential Latency. The comparison of AP latency to rarefaction and condensation click stimuli has also been used in ECochG as a diagnostic indicator of Ménière's disease. In patients with Ménière's disease, the AP latency differs with the presentation of a condensation versus rarefaction click stimulus. It is likely that the endolymphatic hydrops leads to biasing of the basilar membrane toward the scala tympani (Ohashi, Nishino, Arai, Hyodo, & Takatsu, 2009). To condensation clicks, this would increase the time it takes the basilar membrane to displace from its initial downward, inhibitory position to the upward position causing hair cell depolarization (Margolis et al., 1995; Orchik, Ge, & Shea, 1998). Rarefaction clicks should experience minimal latency delay as initial displacement leads to neural firing (Margolis et al., 1995; Orchik et al., 1998). Orchik et al. (1998) compared the latency shift in individuals with definite Ménière's disease and individuals without Ménière's disease, but with other inner ear disorders. A criterion of greater than 0.2 ms was used as an indication of prolonged latency between condensation and rarefaction AP latencies (Orchik et al., 1998). Using this criteria, Orchik et al. (1998) found a significant difference of the AP latency to condensation and rarefaction clicks in individuals with Ménière's disease, with an average difference of 0.4 ms, when compared to non-Ménière's disease individuals, who displayed an average difference of 0.06 ms. While significant differences were seen between the subject groups, the overall sensitivity of the test remained relatively low at 62% (Orchik et al., 1998). Others continue to report low sensitivity of this indicator; Ohashi et al. (2009) found that sensitivity of the AP latency shift alone was 50%, and was

most often associated with later stages of the disease. Though not sensitive enough to stand alone, it is often examined in combination with other ECoChG measures as an indicator of Ménière's disease.

Further Limitations of ECoChG in Ménière's Disease. Another important consideration in the use of ECoChG for the assessment of Ménière's disease is the relative fluctuation of symptom, especially in the early stages of the disease's progression when the endolymphatic hydrops may be intermittent (Conlon & Gibson, 2000). ECoChG will therefore be most sensitive when the patient is symptomatic (Conlon & Gibson, 2000; Ferraro, Arenberg, & Hassanein, 1985). This presents a challenge when clinically evaluating the disorder, as the variable fluctuation of symptoms make it difficult to schedule a test during symptomatic periods, and patient's with the disease may be wary about or unable to undergo the evaluation when symptomatic (Ferraro et al., 1985; Ferraro & Tibbils, 1999). In the later stages of the disease, this likely become less of an issue as initially normal electrocochleograms in individuals with Ménière's disease, may become abnormal with the progression of the disease (Gibson & Conlon, 2000). However, the value of the objective testing for appropriate diagnosis of Ménière's disease remains greatest in the early stages, especially as in later stages of the disease the greater degree of sensorineural hearing loss may preclude the use ECoChG (Ferraro, 2010). Ferraro (2010) suggests that hearing sensitivity above a moderate loss through 1000 Hz – 4000 Hz, and above a 60 dB HL loss at 500 Hz limits the use of ECoChG in the diagnosis of Ménière's disease, as the recorded potentials become unreliable or all-together absent. As the early stages of Ménière's are characterized initially by low-frequency fluctuations of hearing loss, it is suspected that the apex of the cochlea is more sensitive to the disease

progression (Filipo & Barbara, 1997). As low frequency hearing sensitivity is likely initially disrupted by mechanism of the disease, the examination of low frequencies may allow for greater detection during early stages of the disease.

Tone Burst Electrocochleography. As discussed above, no current click ECoChG protocol when examined alone carries a sensitivity value which would allow for confident detection of the disease in suspected patients with Ménière's disease. Thus, development and refinement of test protocol continues. As with many other auditory evoked potentials (AEPs), one such area of examination is the use of frequency specific stimuli. Tone burst stimuli have been examined in ECoChG and evaluated as a potential measure to improve its diagnostic capabilities. The ability to utilize frequency specific stimuli in the diagnosis of Ménière's disease has allowed researchers to assess how the potentials differ across frequencies. This is especially important as hearing sensitivity fluctuates in the low frequencies during the early stages of the disease, and it is believed that apex is affected by the endolymphatic hydrops before the basal portions of the cochlea (Filipo & Barbara, 1997). Examining responses from low to high frequencies provides further information as to how the cochlea is affected in cases of Ménière's disease. The use of tone burst stimuli in ECoChG has allowed for the examination of the SP and AP across frequencies, both of which are greatly altered when compared to the typical click recording.

Both the latency and amplitude of the AP can be affected by the use of tone burst stimuli. To high frequency stimuli the AP latency is shorter than it is when collected using low frequency stimuli, which prolong the latency of the AP (Ferraro et al., 1994a; Mouney et al., 1976). This is due to the tonotopic organization of the cochlea, with high

frequencies represented at the base and low frequencies at the apex. Thus, the travelling wave takes longer to reach maximum displacement to low frequency stimuli as it must travel farther along the basilar membrane (Ferraro et al., 1994a; Mouney et al., 1976). The rise time of the stimulus envelope can also affect presence of the AP, with shorter onsets leading to earlier AP latency, and longer onsets (greater than 5 ms) causing little to no AP response in the waveform (Levine et al., 1992; Mouney et al., 1976). With the use of low frequency tone burst stimuli the AP amplitude will also be reduced, since there is less synchronous firing from the apex of the cochlea as energy of the traveling wave is lost as it moves toward the apex (Ferraro et al., 1994a). The AP to tone burst stimuli is highly dependent on the frequency of the stimulus used, is variable across recordings, and is often obscured by the SP, limiting its overall diagnostic value in tone burst ECoChG (Ferraro et al., 1994a). As a result, tone burst ECoChG evaluations have primarily focused on the use of the SP as a diagnostic indicator.

The SP is highly dependent on the characteristics of the presented stimulus, including the duration of the eliciting stimulus and under ideal conditions would persist for the length of the stimulus envelope (Ferraro et al., 1994a). Tone burst stimuli are, by necessity, longer in duration when compared to click stimuli, which makes them useful in the examination of the SP by significantly lengthening the presence of the SP within the waveform. This is in contrast to the SP recorded by a click stimulus, where the potential is obscured by the AP and is limited by the short duration associated with the click (Ferraro et al., 1994a). However, with the use of long duration tone burst stimuli the SP will extend past, or completely obscure the AP (Ferraro et al., 1994a). At present time, the majority of research relevant to tone burst ECoChG has used relatively long stimulus

durations (≥ 12 ms) in the examination of the SP, which remains present for duration of the stimulus. While this allows for clear observation of the SP, it limits the repetition rate at which tone burst stimuli can be presented without overlap of the signal. As such, repetition rate, a potentially significant factor in the collection of tone burst ECoChG is limited. A thorough examination of the SP response to varying stimulus duration is warranted in order to examine the changes to the waveform associated with variable stimuli duration.

As was the case to click stimuli, the SP amplitude is also increased in the presence of endolymphatic hydrops. This increase and the use of tone burst stimuli to record a relatively unobscured SP has led to the examination of the SP amplitude and its ability to determine the presence or absence of Ménière's disease. Gibson (1993) was one of the first to develop criteria for tone burst stimuli to aid in the differentiation of ears with and without Ménière's disease. Gibson (1993) determined using TT, tone burst ECoChG that of the frequencies evaluated (in octave steps, 500 – 8000 Hz), 500 Hz and 1000 Hz were the most effective in establishing a diagnosis of Ménière's disease, while 4000 Hz was the least effective when evaluating the SP amplitude. Gibson (2009) repeated the study with matched hearing loss controls (ears without Ménière's disease, but with sensorineural hearing loss). Results showed that 500 Hz, 1000 Hz, and 2000 Hz were most sensitive in distinguishing between the Ménière's disease and the control groups, while significant overlap between the two groups occurred at 4000 Hz and 8000 Hz. Gibson (1993; 2009) also compared these results to click stimuli SP/AP amplitude ratio measurements, and determined the use of tone burst SP amplitude as a sensitive measure

to Ménière's disease. These findings support the use of low frequency stimuli in tone burst ECoChG measures when examining the effects of Ménière's disease.

Others have found similar results when comparing click evoked SP/AP amplitude ratios to SP amplitudes obtained from 1000 Hz tone burst stimuli with the use of TT ECoChG (Conlon & Gibson, 2000; Iseli & Gibson, 2010). However, Al-momani et al. (2009) reported that with the use of ET recording measures and 1000 Hz and 2000 Hz tone burst stimuli, no significant difference was noted between the SP amplitude of non-Ménière's disease ears and ears with Ménière's disease. It was suggested that this inconsistency may have been due to the ET recording method which may be less sensitive to the change in the SP amplitude as a result of the endolymphatic hydrops (Al-momani et al., 2009). While this may be a limitation of the use of tone burst ECoChG in clinical situations where non-invasive recording methods are routinely used, further evaluation of the reliability and validity of ET tone burst ECoChG is certainly required.

The wide range of parameters used in the evaluation of tone burst ECoChG is a factor which often makes it difficult to compare the responses across studies. Ferraro and Durrant (2006) noted that across research settings there has been no standardization of the recording methods or stimulus parameters used with tone burst ECoChG. This is easily discovered when examining the literature as recording sites, electrode placement, filter settings, and stimulus duration, envelope and rate are often varied across studies. There has yet to be an established protocol which defines the most sensitive parameters for the collection of tone burst ECoChG.

High Repetition Rate Electrocochleography. Auditory electrophysiological recording to high repetition rate has been routinely evaluated in the literature as a method

of assessing the auditory system. Several researchers have investigated the use of high repetition rate with AEPs and reported significant changes to the measured waveform, citing the neural adaptation, the de-synchronization of neural firing, occurring as repetition rate increases (Kaf et al., 2017; Wilson and Bowker, 2002). As is true with other electrophysiological measures, ECochG is also sensitive to increasing repetition rate. Using click evoked, ET ECochG, Wilson and Bowker (2002) established the effect of high stimulus rates with click stimuli (up to 151 clicks/second) on subjects with normal hearing sensitivity; they determined that with increased repetition changes to all waveform components could be seen, including AP amplitude and latency, SP amplitude and latency, SP/AP amplitude ratio, and waveform width. Wilson and Bowker (2002) noted that significant reduction of the AP amplitude as repetition rate increased. Likely due to the fatigability of the auditory nerve to repetitive stimulation (Wilson & Bowker, 2002). The SP amplitude, however remained relatively stable as stimulus rate increased (Wilson & Bowker, 2002).

The stability of the SP with increasing repetition rate, however, may not hold true with the use of tone burst stimuli. Wuyts et al. (2001) examined the effect of rate on TT ECochG using 1000 Hz tone burst stimuli in subjects diagnosed with definite Ménière's disease compared to subjects without Ménière's disease but who were experiencing hearing loss, tinnitus, or vertigo. Rate was varied between 8.4-37.4 tone bursts/second and revealed that SP amplitude increased with increased rate regardless of the presence or absence of the disease (Wuyts et. al, 2001). It was hypothesized that increased repetition rate causes a non-linearity on the basilar membrane, as it has not returned to its original position before the onset of the next stimulus, which influences the recorded SP

amplitude (Wuyts et al., 2001). In fact, Wuyts et al. (2001), noted a slower growth in SP amplitude to increasing rate in individuals with endolymphatic hydrops, which was suspected to be the result of the increased pressure limiting the movement of the basilar membrane. This change in the SP with increasing rate using tone burst stimuli is in contrast to the stable SP findings recorded using click ECoChG (Kaf et al., 2017; Wilson & Bowker, 2002). Wuyts et al. (2001) evaluated TT tone burst ECoChG, only up to a repetition rate of 37.4 tone bursts/second. However, there is limited research about the use of ET recording of tone burst ECoChG with increasing and very high repetition rates. Based on Wuyts et al.'s (2001) findings supporting a change in the SP using 37.4/s tone burst ECoChG, with a more pronounced effect noted in subjects without a diagnosis of Ménière's disease, further examination is warranted. As individuals with presenting otologic symptoms were used as a control group, the evaluation of a population with normal hearing sensitivity and the absence otologic pathology should be evaluated to determine the physiologic change in the SP with increasing rate and to evaluate the effect of a much higher repetition rate on the ECoChG response.

In a study applying high repetition rate, Gibbin, Mason, and Singh (1981) examined click and tone burst, ET ECoChG in the evaluation of SP changes with the administration of glycerol in patients with Ménière's disease. The authors utilized a 4000 Hz tone burst stimulus presented at a repetition rate of 200 tone bursts/s in order to reduce the presence of the AP through adaptation (Gibbin et al., 1981). As is expected in those with Ménière's disease an enhanced SP amplitude was found prior to the glycerol injection, with subsequent reduction in SP amplitude after administration (Gibbin et al., 1981). However, Gibbin et al. (1981) note that the SP amplitude was difficult to measure

under the 4000 Hz, 200 tone bursts/second condition compared to the results obtained from click ECoChG, as the AP did not fully adapt and was still apparent within the recording.

Previous reports demonstrated that recorded waveforms to high rates are significantly degraded and difficult to interpret using the standard measure (Delgado & Ozdamar, 2004). Thus, recording ECoChG to very high repetition rates requires a special technique to help analyze the complex, overlapped waveforms. One such method, maximum length sequences (MLS) is a pseudorandom binary sequence, which allows for the use of shorter inter stimulus intervals between evoking click stimuli, thus a higher repetition rate, through the application of a specific mathematical formula, which enables the complex waveform to be deconvolved, creating an accurate representation of the underlying electrophysiological response (Eysholdt & Schreiner, 1982). While MLS has been successfully applied across AEPs, especially in auditory brainstem response and middle latency responses, it faces limitations as the optimal repetition rate remains between 200/s – 300/s and the possibility of high jitter present in the sequences (Leung, Slaven, Thornton, & Brickley, 1998; Delgado & Ozdamar, 2004). However, a novel method, continuous loop averaging deconvolution technique, has recently been developed in order to examine very high repetition rates (up to 1000/s) while maintaining signal to noise ratios and the integrity of the resulting waveform (Delgado & Ozdamar, 2004).

High Repetition Rate using Continuous Loop Averaging Deconvolution with Electrocochleography.

Continuous loop averaging deconvolution (CLAD) is a mathematical, computerized algorithm that allows AEPs to be evaluated using transient stimuli at very high repetition rates (Delgado & Ozdamar, 2004). During conventional AEP recordings, repetition rate is kept low enough to ensure that the waveforms do not overlap within the sequence, to avoid obscuring the collected waveforms (Delgado & Ozdamar, 2004). CLAD has been designed to overcome this limitation by using complex mathematical algorithms to deconvolve or unwrap waveform obtained at very high stimulus rates (Bohorquez et al., 2009; Delgado & Ozdamar, 2004). Time and frequency domain characteristics are used in an algebraic matrix to allow for the examination of deconvolved waveforms at numerous rates up to 1000/sec (Ozdamar & Bohorquez, 2006). Its use in clinical applications has included ECochG, auditory brainstem response (ABR), and auditory middle latency response (AMLR), and auditory steady-state response (Bohorquez et al., 2009; Ozdamar & Bohorquez, 2006).

Bohorquez et al. (2009), evaluated CLAD and its use in TT ECochG recording. Using TT ECochG with click stimuli, the repetition rate was varied between 58/s and 780/s, in patients with Ménière's disease, acoustic neuromas, and in control subjects with normal hearing (Bohorquez et al., 2009). With CLAD, it was revealed that AP amplitude was significantly reduced with increased repetition rate, with reduction starting at a lower rate (100/s) in patients with acoustic neuromas as the nerve fatigued more quickly in these patients (Bohorquez et al., 2009). The SP amplitude remained stable in both the normal hearing sensitivity and acoustic neuroma groups, though in participants with

Ménière's disease, SP amplitude was found to be more variable with higher rates (Bohorquez et al., 2009). Recently, Bextermueller (2015) and Dixon (2015) used the CLAD technique with click ECoChG and click ABR in the examination of individuals with normal hearing, Ménière's disease, and vestibular migraines; though, the small sample size of both the Ménière's disease and vestibular migraine group limits the ability to make general statements from the data of those participants. However, in participants with normal hearing, Kaf et al. (2017) again found that the SP component remained stable as rate increased, while the AP showed a slight increase in latency and a marked a marked decrease in amplitude with increasing rate, though this decrease eventually stabilized through the higher rates. At each rate, an upper limit of normal was defined in order to examine the SP/AP amplitude ratio. Significant variability in the SP/AP amplitude ratios was found at high rates, and at each rate one to two participants had SP/AP amplitude ratios which fell outside of the normal range, potentially limiting the usefulness of this measure at high repetition rate (Dixon, 2015).

To the author's knowledge, the use of the CLAD technique with tone burst ECoChG to high rates has yet to be examined. Click stimuli for ECoChG recordings are well suited to high repetition rates, as the short, 100 μ s duration can be presented very fast without the concern of stimulus overlap. However, as tone burst stimuli are longer in duration, considerations must be made regarding the upper most repetition rate that can be used without causing overlap of the stimulus itself. Further evaluation of CLAD in tone burst ECoChG measurements will allow for improved understanding of how increased repetition rate affects SP amplitude, which may be valuable in diagnosing Ménière's disease and in other ECoChG applications.

OBJECTIVE

Limited research is available examining the use of tone burst stimuli presented at high repetition rates in the recording of ECoChG on either normative and pathologic populations. As the current sensitivity of standard ECoChG used in the clinical differential diagnosis of Ménière's disease is relatively low, the use of high click rate ECoChG with the CLAD technique may offer a new method in the evaluation of otoneurologic disorder. Although initial reports look promising, as a novel technique, limited research is available regarding its efficacy for both healthy individuals and those with auditory pathology as well as its use with tone burst stimuli.

ECoChG recording using a TM electrode in lieu of the more invasive TT needle electrode has received a great deal of attention in the literature. While multiple studies have evaluated the differences between electrocochleograms obtained using ET versus TT recording methods (Ferraro et al., 1994b; Haapaniemi et al., 2000; Mori, Saeki, Matsunaga, & Asai, 1982); relatively few studies have assessed the potential changes that occur within the auditory system with the introduction of TM electrode (Smith et al., 2016; Stypulkowski & Staller, 1987). As frequency specific stimuli are used during ECoChG measurements, it is important to assess potential changes in the auditory pathway across frequencies that may come as a result of electrode placement directly on the TM.

The aim of this study is to establish normative ET tone burst ECoChG CLAD data from adults with normal hearing sensitivity using high rate and 500 Hz and 2000 Hz stimuli of different duration. Specifically, the objective of the present study is the

investigation of the effects of high rate and stimulus duration on 500 Hz and 2000 Hz tone burst ECochG SP amplitude in adults with normal hearing. As a secondary objective, the effect of electrode placement on the TM on hearing thresholds is examined.

METHODS

Participants

This study was approved by the Missouri State University Institutional Review Board (February 23, 2016; study #16-0292). Twenty-one adults with normal hearing sensitivity were recruited for participation in this study. Participants were recruited through word-of-mouth, e-mail, and convenience sampling with all volunteers being Missouri State University students or faculty. Criteria for participation in the study included: (1) otoscopic evaluation revealing ear canals clear of cerumen or debris, (2) normal hearing sensitivity determined by pure tone air conduction audiometry, with thresholds ≤ 25 dB HL from 250-8000 Hz (Goodman, 1965); (3) normal middle ear status as confirmed by 226 Hz tympanometry and the presence of normal static compensated admittance, tympanometric pressure, and ear canal volume (American Speech-Language-Hearing Association, 1988); and (4) a recordable SP and AP with standard click ECoChG measurements. Though Wilson and Bowker (2002) report that age did not have a significant effect on the collection of click ECoChG components at high stimulus rate for either ear, its potential effect on tone burst ECoChG at high rates has not been evaluated. To control for potential age-related changes to high rate tone burst ECoChG to the evoked responses such as the increased latency and decrease amplitude of waves described with advancing age (Khatoon, Nighute, Awari, & Ishaque, 2012; Patel, Shah, & Mehta, 2014), the age range of participants evaluated was 20 – 35 years. Informed consent was obtained from each participant prior to the start of the evaluation.

Equipment

All participants were tested in the sound booth at the Missouri State University, auditory research laboratory. Otoscopy was performed using a Welch Allyn otoscope in order to assess the ear canal and TM before further evaluation took place. Tympanometry using a 226 Hz probe tone was performed to evaluate each participant's middle ear status using the Grason-Stadler Inc. TympStar (serial number: 00040590). Intelligent Hearing Systems SmartAudiometer (serial number: IHS3110) was used to assess hearing thresholds from 250 – 8000 Hz using pure tone stimuli presented via ER-3A insert earphones under sound booth conditions. Intelligent Hearing Systems Smart-Evoked Potential equipment (serial number: IHS3110) was used for the ET ECoChG recordings; with ER-3A insert earphones used to deliver the stimuli. The equipment was calibrated according to manufacturer specifications, using a precision sound level meter (Quest, Model 155), microphone (Bruel & Kjaer, Model 4144), and a 2-cc (HA-2) coupler (Bruel & Kjaer, Model DB-0138) and followed the IEC standard for peSPL (0 dB nHL = 32 dB peSPL \pm 3 dB). Pre-gelled, disposable surface electrodes were used as the non-inverting electrode placed on the ipsilateral mastoid and the ground electrode placed on the contralateral mastoid. A homemade tympanic electrode was used as the inverting electrode placed on the TM. TM electrodes were constructed based on Ferraro and Durrant (2006) instructions. The materials used to construct the electrodes included bare silver wire (0.008 inch diameter), silicon tubing (0.0077 inch outer diameter; 0.058 inch inner diameter), cotton balls, electrode conducting gel, and a needle syringe. A microalligator clip was used to connect the wire end of the TM electrode to the pre-amplifier.

Stimulus and Recording Parameters

Electrode Montage and Impedance. A one channel montage was used for ECoChG recording from the test (right) ear of each participant. The inverting TM electrode was placed on the TM of the right ear, the non-inverting electrode was placed on the ipsilateral (right) mastoid, and the ground electrode was placed on the contralateral (left) mastoid. See Figure 1 for electrode placement montage. Ferraro et al. (1994a) suggest the use of an ipsilateral montage in order to reduce the contribution of later waves associated with ABR in the response. Electrode impedance was kept $\leq 7 \Omega$ at each electrode site.

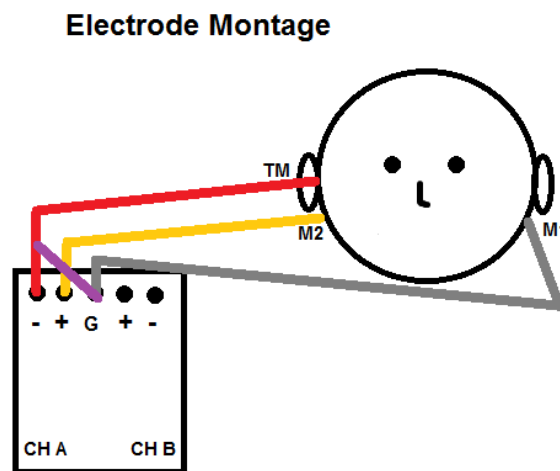

Figure 1. Ipsilateral electrode montage. Red = Right TM inverting electrode; Orange = Right mastoid non-inverting electrode (M2); Purple = Shield from TM electrode to ground; Grey = Left mastoid ground electrode (M1)

Standard ECoChG. Prior to the collection of tone burst ECoChG at high rate, standard, slow rate click ECoChG was performed for the right ear. This step allowed for a clear observation of the SP and AP components in the waveform to ensure these

potentials were present under standard ECochG parameters prior to the implementation of the test protocol. 100 μ s broad-band click stimuli were presented at 75 dB nHL, with alternating polarity and at a rate of 7.1/s. The recording epoch was set for 5 ms. A band-pass filter setting of 10 - 3000 Hz and a gain setting of 100,000 were utilized. Two traces were collected, each recorded for 1000 sweeps.

Tone burst ECochG with CLAD. As shown in Table 1, 500 Hz and 2000 Hz tone burst trapezoid stimuli were presented across varying rates in a random order determined a priori. 500 Hz and 2000 Hz stimuli were chosen based on Gibson's (2009) study indicating that these frequencies, as well as 1000 Hz, were found to show significant differences in the SP amplitude between ears with Ménière's disease to ears without the disease and because the fluctuation of hearing thresholds typically begins at low frequencies in these patients with Ménière's disease.

For the present study, the rate values examined included 7.1/s, 19.53/s, 58.59/s, 97.66/s, and 234.38/s. All rates, with the exception of 7.1/s, are CLAD rate sequences that were developed and evaluated by Intelligent Hearing Systems for their ability to deconvolve the recorded response using the CLAD algorithm. These four CLAD stimulus rates were chosen in order to ensure no overlap in the recording based on the stimulus durations of the tone burst stimuli. As stimulus rate is limited by the stimulus duration, higher rates could not be used without the potential of overlap in the stimulus signal which would be detrimental to the recordings. Loopback recordings of the 500 Hz and 2000 Hz stimuli were performed at each rate to ensure no overlap occurred within the stimulus. Figure 2 from the loopback recording of 500 Hz shows the 500 Hz stimulus across rates for 3 ms, 6 ms, and 12 ms durations.

Table 1. Stimulus and recording parameters for the ECoChG Measurements

Parameters	Tone Burst ECoChG using CLAD	Standard Click ECoChG
Stimulus frequency	500 Hz, 2000 Hz	Click
Stimulus duration	12 ms: 2-10-2 rise-plateau-fall time 6 ms: 2-2-2 rise-plateau-fall time 3 ms: 1.5-0-1.5 rise-plateau-fall time	100 μ s
Rate (Organized by Stimulus Duration)	12 ms: 7.1/s, 19.53/s, 58.59/s 6 ms: 7.1/s, 19.53/s, 58.59/s, 97.66/s 3 ms: 7.1/s, 19.53/s, 58.59/s, 97.66/s, 234.38/s	7.1/s
Polarity	Alternating	Alternating
Intensity	75 dB nHL	75 dB nHL
Sweeps	2000	1000
Recording Window	12 ms	5 ms
Band pass filter	3 – 3000 Hz	10 – 3000 Hz
Gain	100,000	100,000
Electrode Montage	Non-inverting – right ipsilateral mastoid (M2) Inverting – right ipsilateral tympanic membrane (TM2) Ground – left contralateral mastoid (M1)	

For the ECoChG recordings, each trace was repeated to ensure replicability, with the 2000 sweeps per trace. The recording epoch was set at 12 ms. As with standard ECoChG, recordings were made using an alternating polarity signal and gain of 100,000.

The band-pass filter was set to 3 - 3000 Hz; a high pass filter of 3 Hz was used because the SP, as a direct current potential, is particularly sensitive to high pass filter settings. The use of a high pass filter of 3 Hz is thought to minimize the distortion present in the SP signal (Ferraro et al., 1983).

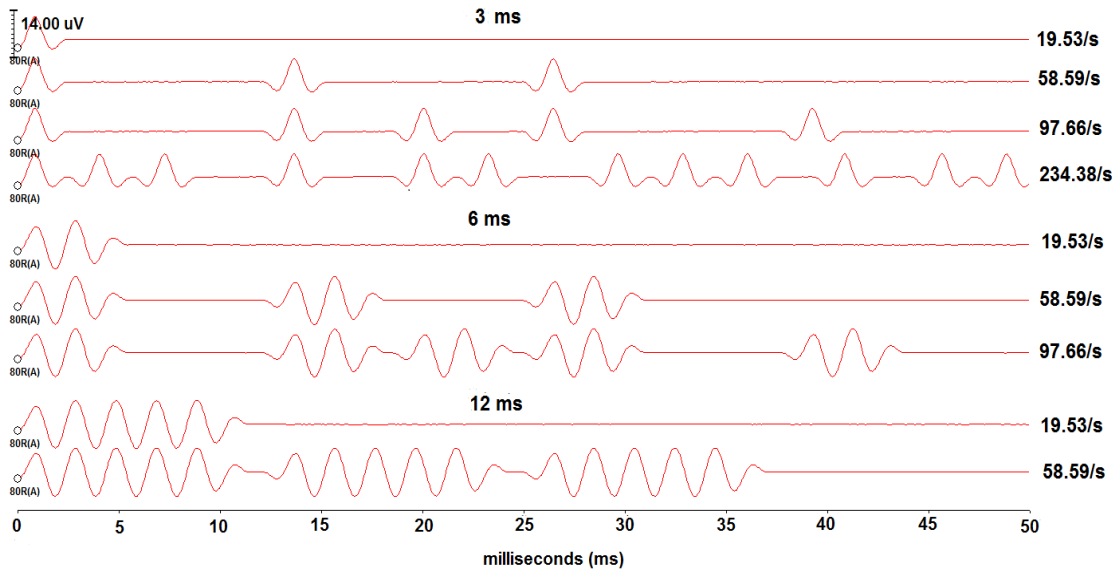

Figure 2. 500 Hz loopback recordings at 3 ms, 6 ms, and 12 ms duration tone burst stimuli organized by rate. The figure shows tone burst stimuli organized by duration and rate from top to bottom: 3 ms duration at 19.53/s, 58.59/s, 97.66/s, and 234.38/s (top panel); 6 ms duration at 19.53/s, 58.59/s, and 97.66/s (middle panel); and 12 ms duration at 19.53/s and 58.59/s (bottom panel). Recording shows no overlap occurred in stimulus signal at any of the stimulus durations and their corresponding rates.

To examine the effect of rate on SP amplitude response as a function of stimulus duration, recordings were conducted with stimulus durations of 12 ms, 6 ms, and 3 ms for each rate in which no overlap would occur. For example, at 19.53/s all durations (12 ms, 6 ms, and 3 ms) were examined as no overlap occurs at this rate. On the other hand, at a higher rate such as 234.38/s only the 3 ms stimulus duration was examined due to the stimulus overlap that would result from testing using the longer duration stimuli. A 2 ms

rise and fall time with an 8 ms plateau (2-8-2) was used for the 12 ms duration stimuli and a 2 ms rise and fall time with a 2 ms plateau (2-2-2) was applied for the 6 ms duration stimuli for both the 500 Hz and 2000 Hz conditions. For the 3 ms duration stimuli, rise and fall times of 1.5 ms were used, with no plateau (1.5-0-1.5).

Procedures

Following recruitment participants were scheduled for a three-hour test session. Informed consent was reviewed with the participant, and benefits and risks of the study were discussed along with what can be expected during the testing. The right ear of each participant was evaluated. Otoscopy was performed prior to all other evaluations to ensure the ear canals were clear and there was no evidence of pathology. Tympanometry using a 226 Hz probe tone was used to assess middle ear status, and rule out any middle ear pathology which could confound ECoChG results. A pure tone hearing evaluation from 250-8000 Hz was performed to obtain hearing thresholds. Participation in the study was dependent on hearing sensitivity of at least 25 dB HL across the tested frequencies and normal middle ear status as well as present click ECoChG response.

Standard click ECoChG was performed on the right ear on all participants. Though not formally analyzed, standard ECoChG was performed on all participants in order to ensure a reliable and replicable click ECoChG could be obtained prior to the collection of tone burst ECoChG. Two traces were recorded, averaged and assessed to ensure the presence of both the SP and AP waveform components of the ECoChG before proceeding with the experimental, tone burst ECoChG protocol. In a laboratory environment, participants were comfortably seated in a reclining chair. The participant's

skin was scrubbed gently with Nu-Prep gel on the electrode site areas, the participant's right (M2) and left (M1) mastoids. Disposable surface electrodes were then placed and attached to these sites. Next, the TM electrode was inserted along ear canal and slowly moved toward the TM. The patient was informed that they would feel a slight pressure as the electrode came in contact with the TM. The patient was instructed to provide verbal feedback regarding their comfort and the pressure sensation accompanying the contact of electrode with their TM. The electrode placement was guided by otoscopy, patient report of TM contact, and electrode impedance measure of less than 7 k Ω . Following placement of the TM electrode, an ER-3A insert earphone was placed in the ear canal to hold the electrode in place and deliver the sound stimuli. At this point, pure tone air conduction audiometry was re-evaluated with the electrode on the TM. The portion of the electrode protruding from the ear canal was taped down to the side of the participant's face and attached to a microalligator clip. Participants were reclined, instructed to relax, and encouraged to take a nap during standard click ECoChG and experimental tone burst ECoChG testing to 500 Hz and 2000 Hz.

Following recording of standard click ECoChG, tone burst ECoChG to 500 Hz and 2000 Hz were recorded. The order of the tone burst stimuli and the repetition rates was randomized a priori to eliminate any order effect. At each repetition rate, the appropriate stimulus durations were adjusted from long to short duration as applicable. With each duration and rate, two traces of 2000 sweeps each were recorded. Once all recordings from the right ear at both 500 Hz and 2000 Hz were completed, the TM electrode was removed from the participant's ear and otoscopy was performed to rule out any sign of injury to the ear canal and TM as a result of TM placement and to assess TM contact

location. Areas of redness and electrode gel on the TM can be used as indicators of electrode contact area (Smith et al., 2016). The ER-3A insert earphone was then re-inserted in the right ear and pure tone hearing thresholds were re-established for the third time following electrode removal. This last step concluded the test session and the participant was thanked for their participation in the study.

Data Analysis

Analysis of the recorded waveforms occurred offline. The two recorded traces from each condition were averaged. These averaged waveforms were then deconvolved using the CLAD algorithm, and the resulting traces were labeled to determine the SP amplitude. Uniform labeling was used across all deconvolved waveforms according to the frequency and duration of the recording; rate was not a factor in the labeling of the waveforms. Figure 3 and figure 4 depict the labeling method used for the 500 Hz and 2000 Hz waveforms across the three durations examined. As shown in figures 3 and 4, the SP amplitude measurements were made from the midpoint of the stimulus duration, beginning at the onset of the response, to the baseline. SP amplitude measurement from the midpoint of the response is a common practice in the recording of tone burst ECoChG and is thought to allow for SP measurement to be made without contribution from the AP at the onset of the response and prior to SP decay at the end of the response (Gibson, 1993; Gibson, 2009; Ferraro et al., 1994a; Ferraro et al., 1994b; Wuyts, et al., 2001). For 12 ms, 6 ms, and 3 ms stimulus durations, the midpoints were 6 ms, 3 ms, and 1.5 ms respectively. Each of these midpoint measures were made from the onset, the beginning of the response, in order to maintain a uniform SP midpoint latency from which the SP

amplitude would be measured. The onset of the response was chosen as the point at which a positive shift from baseline was noted and was defined as a latency of 1.5 ms for the 2000 Hz condition, and a latency of 2.5 ms for the 500 Hz condition across the recordings from all participants. The onset latency difference between frequencies may be associated with cochlear travel time, which is longer at apical, low frequencies than basal, high frequencies (Ferraro et al., 1994a). All baseline measurements were made at a latency of 1 ms in order to measure SP amplitude from a point prior to the onset of the response.

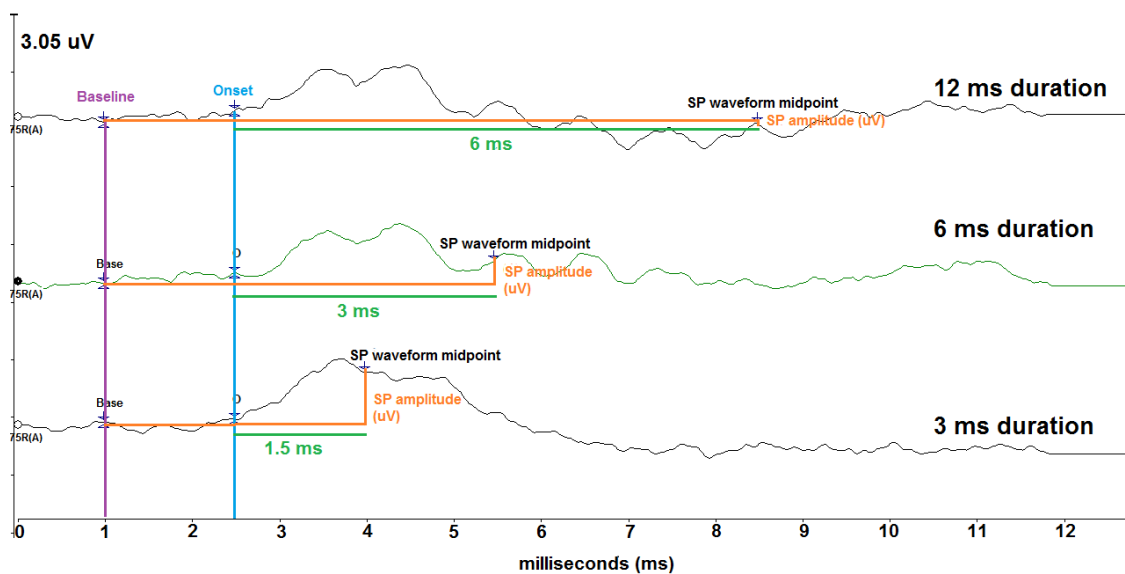

Figure 3. Labeling used for 500 Hz SP recordings across three durations (12 ms, 6 ms, and 3 ms). SP amplitude (μV) was measured from baseline to SP response midpoint (orange line) at 6 ms from SP onset (green line) for the 12 ms duration (top trace); at 3 ms from SP onset (green line) for the 6 ms duration (middle trace); and at 1.5 ms from SP onset (green line) for the 3 ms duration (bottom trace).

Repeated measures analysis of variance (ANOVA) was conducted to compare the effect of rate, duration, and the combination of the two on SP amplitude for both the 500 Hz and 2000 Hz conditions. A 3 (rate – 7.1/s, 19.53/s, 58.59/s) X 3 (duration – 12 ms, 6

ms, 3 ms) within-subject design was utilized in order to assess the interaction across the variables. To evaluate the remaining rates 97.66/s and 234.38/s rates, separate one-way ANOVA for each duration was conducted to compare responses as a function of repetition rate for both frequencies examined. This included comparing three rates (7.1/s, 19.53/s, 58.59/s) at 12 ms durations, four rates (7.1/s, 19.53/s, 58.59/s, 97.66/s) at 6 ms durations, and five rates (7.1/s, 19.53/s, 58.59/s, 97.66/s, 234.38/s) for the evaluation of 3 ms durations.

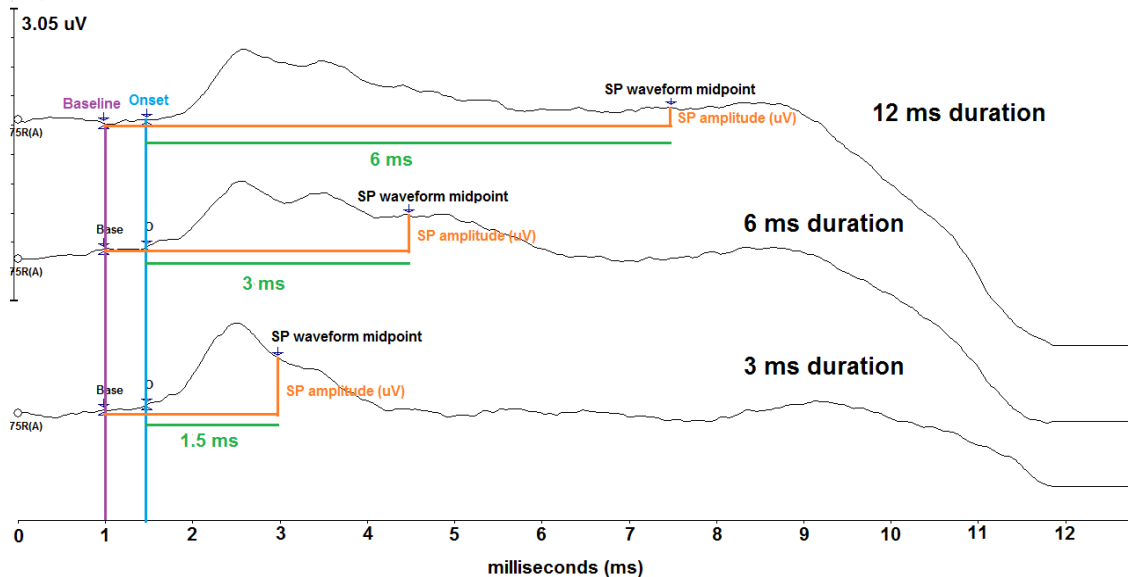

Figure 4. Labeling used for 2000 Hz SP recordings across three durations (12 ms, 6 ms, and 3 ms). SP amplitude (μV) was measured from baseline to SP response midpoint (orange line) at 6 ms from SP onset (green line) for the 12 ms duration (top trace); at 3 ms from SP onset (green line) for the 6 ms duration (middle trace); and at 1.5 ms from SP onset (green line) for the 3 ms duration (bottom trace).

The second objective of this study is to evaluate the change in audiometric threshold across the three test conditions: pre TM electrode placement (baseline), post TM electrode placement (in place), and post TM electrode removal (off place). A 3

(condition – baseline, in place, off place) X 6 (frequency – 250 Hz, 500 Hz, 1000 Hz, 2000 Hz, 4000 Hz, 8000 Hz) within subject repeated measures ANOVA was conducted. Based on the ANOVA results, further statistical analysis was warranted and for the 250 Hz frequency, three, 2-sample t-tests assuming equal variance were utilized to assess threshold differences across all three conditions.

RESULTS

SP Amplitude Data as a Function of Stimulus Rate and Duration

Recordings were completed on 21 participants; however, only data from 20 participants were included in the analysis. Data from one of the participants was excluded due to poor replicability of the tone burst ECoChG waveforms. In addition, data from one participant for the 500 Hz, 234.38/s condition was excluded from the analysis due to an incomplete recording for that rate. All other recordings were included in the data analysis.

Figure 5 displays standard click ECoChG traces for one of the participants (P9). Well defined SP and AP waves, labeled in Figure 5, were used as criteria for the continuation of the experimental procedure of the study to examine tone burst ECoChG responses.

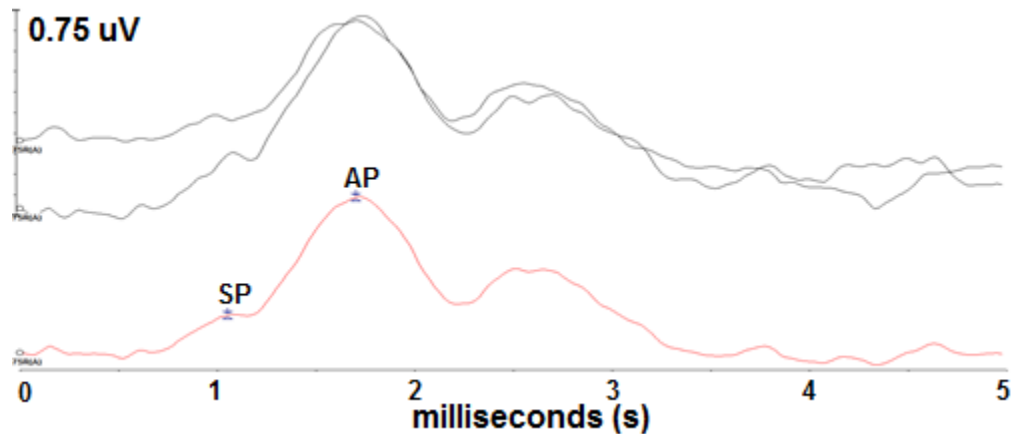

Figure 5. Standard click ECoChG responses from one of the participants (P9). Two traces (black) were recorded and averaged (red) depicting a typical ECoChG response. Standard ECoChG data was not formally assessed during this study.

Non-deconvolved traces for the 500 Hz and 2000 Hz tone burst ECoChG are displayed in figures 6 and 7. Though the SP response is identifiable at slow rates, the response becomes increasingly overlapped at higher rates, as expected, complicating the examination of the complex waveform in the non-deconvolved state. The averaged waveform from each condition was thus deconvolved using the appropriate, rate specific CLAD algorithm, resulting in a deconvolved response, which was then labeled and analyzed to determine the SP waveform amplitude.

Figure 8 depicts the deconvolved tone burst ECoChG responses from one of the participants for the 500 Hz condition for the 12 ms, 6 ms, and 3 ms durations. For the 500 Hz responses, the onset of the SP response began at a latency of approximately 2.5 ms, where a positive shift in amplitude from the baseline was observed. This onset latency remained consistent for each of the three durations (12 ms, 6 ms, and 3 ms) examined and served as the starting latency from which the midpoint of the of the SP response was measured for all participants. To maintain consistent intrasubject measures between rates and durations and intersubject measures between participants, the onset was always marked at a latency value of 2.5 ms for the 500 Hz condition. A comparison of the resulting SP responses can be made across both duration and rate. As the SP is dependent upon stimulus duration, the latency of the SP response changes across duration, with progressively shorter waveforms noted as duration decreases. As expected, the longest SP waveform is observed in the 12 ms duration, while the shortest is noted in the 3 ms duration. Clear differences arose when comparing rates across each of the durations assessed, particularly when comparing slow and high rates. Most notably, oscillations in the waveform can be observed across the slower rates. This pattern is evident across the

slower rates, 7.1/s and 19.53/s, but the waveform begins to smooth and flatten with increasing rate. At the fastest rates evaluated, the oscillation is no longer apparent in the recordings. Ferraro et al. (1994a) report that this oscillation pattern may be a result of phase-locked AP present in the recording.

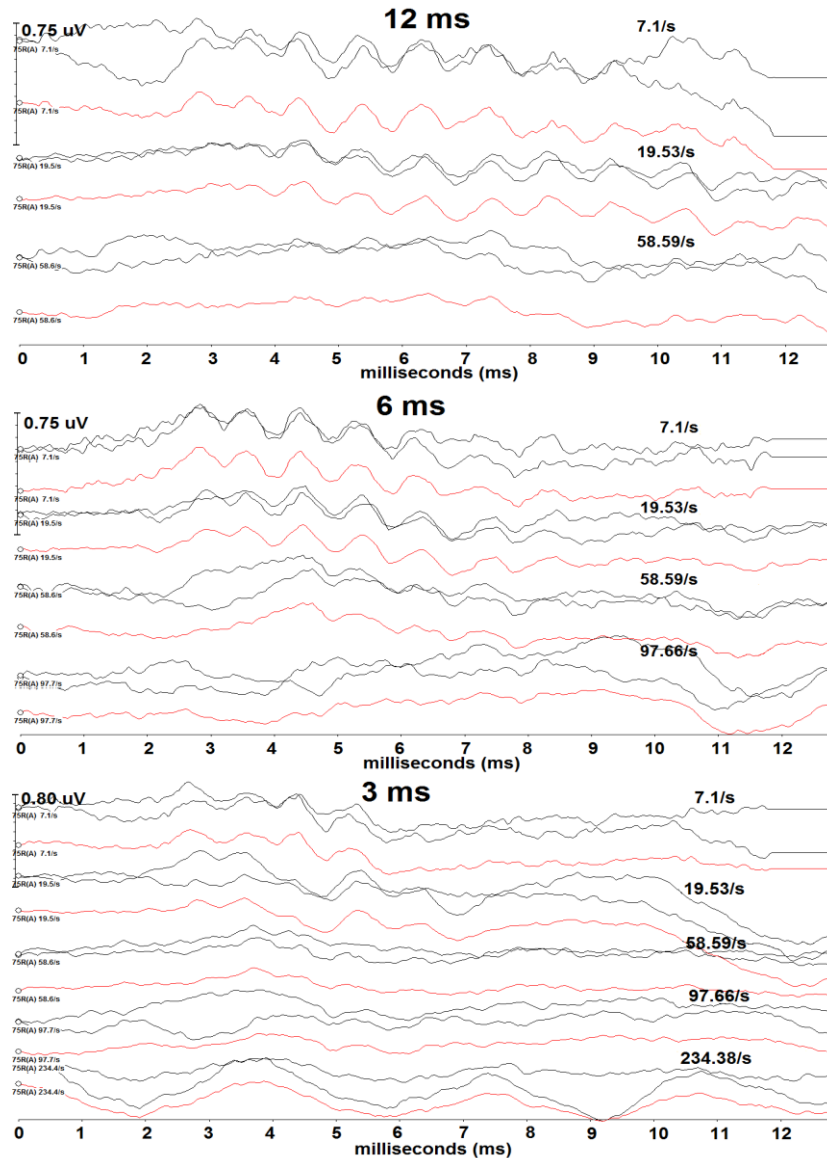

Figure 6. Non-deconvolved tone burst ECoG traces (black) and averages (red) from the same participant (P9) for the 500 Hz condition across duration (12 ms – top; 6 ms – middle; 3 ms – bottom). Traces are displayed with repetition rate increasing from top to bottom for each duration.

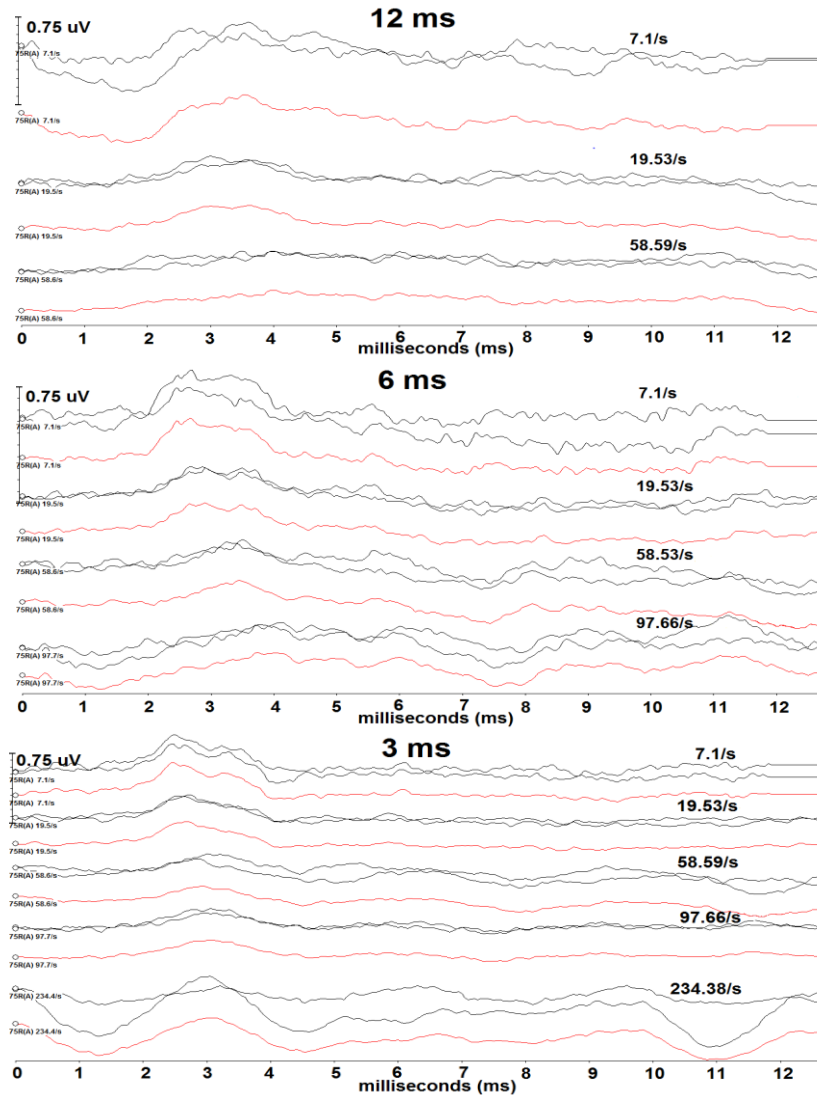

Figure 7. Non-deconvolved tone burst ECoChG traces (black) and averages (red) from the same participant (P9) for the 2000 Hz condition across duration (12 ms – top; 6 ms – middle; 3 ms – bottom). Traces are displayed with repetition rate increasing from top to bottom for each duration.

Figure 9 depicts the 2000 Hz deconvolved recordings from the same participant for the 12 ms, 6 ms, and 3 ms durations. Again, the onset marked the beginning of the SP response and was chosen as the point at which a positive shift from baseline could be observed in the traces. For the 2000 Hz condition the onset was defined as a latency of 1.5 ms. The onset was kept constant at 1.5 ms for each rate and duration and across all

participants. The onset gives rise to the SP response which was assessed across both rate and duration. Again, the length of the SP response is highly dependent upon stimulus duration, with the longest SP waveform found for the 12 ms duration and the shortest found for the 3 ms duration.

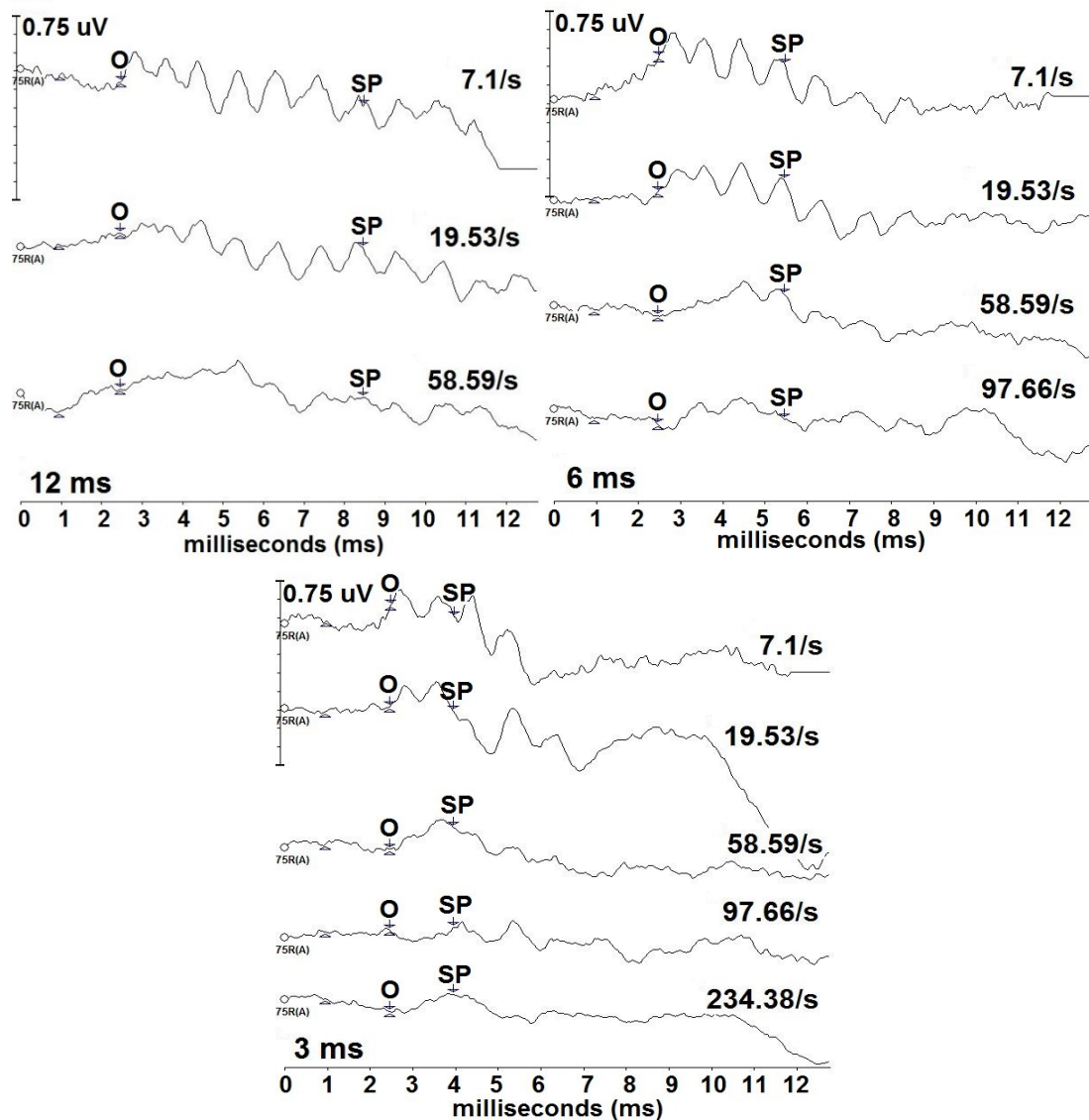

Figure 8. CLAD deconvolved tone burst ECoG waveforms from one of the participants for the 500 Hz condition across stimulus duration (12 ms – left; 6 ms – right; 3 ms – bottom). Traces are displayed with repetition rate increasing from top to bottom for each duration. SP amplitude was measured from the baseline (1 ms) to SP waveform midpoint (SP). Waveform midpoint (SP) was measured from onset (O).

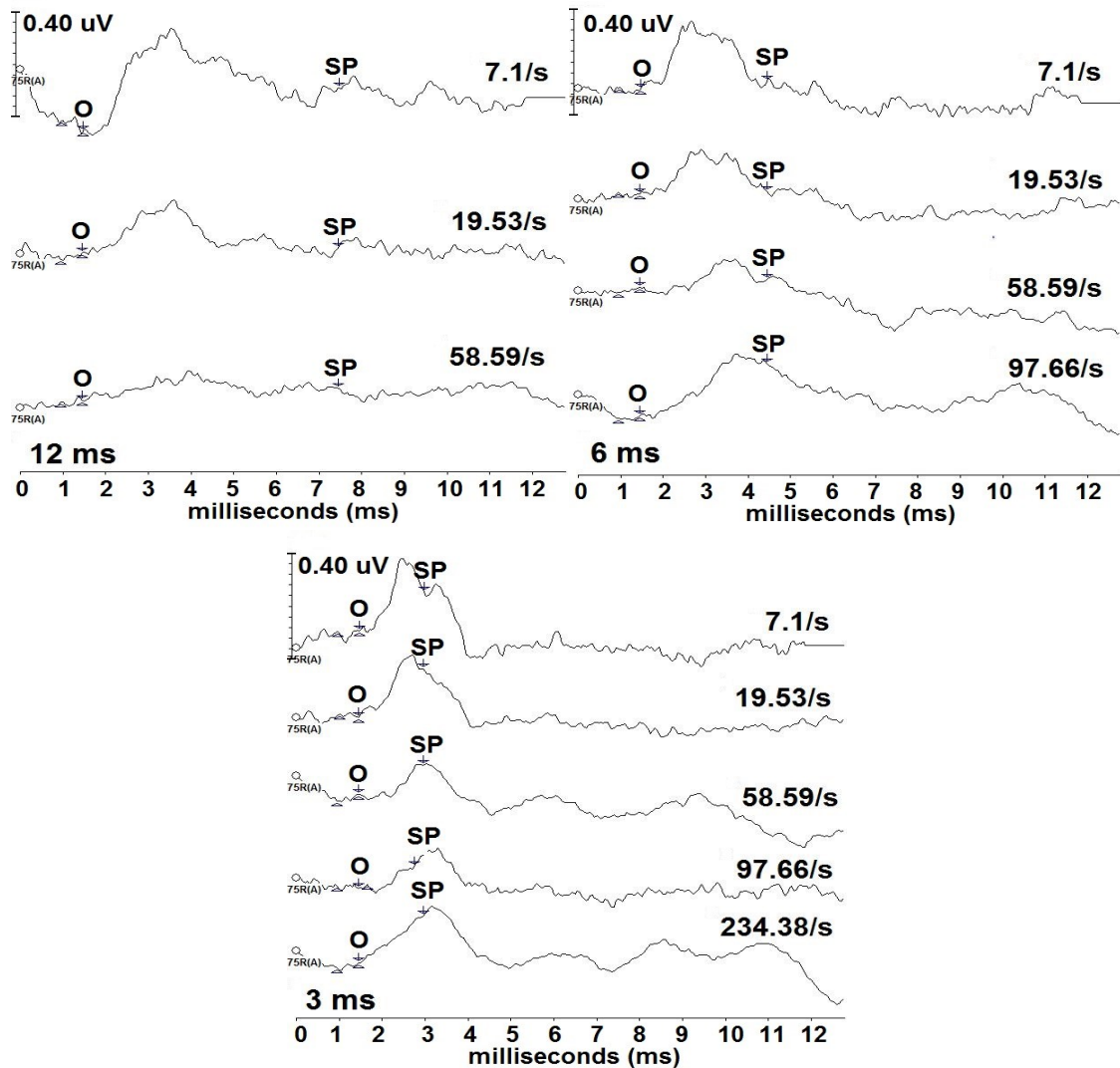

Figure 9. CLAD deconvolved tone burst ECoG waveforms from one of the participants for the 2000 Hz condition across stimulus duration (12 ms – left; 6 ms – right; 3 ms – bottom). Traces are displayed with repetition rate increasing from top to bottom for each duration. SP amplitude was measured from the baseline (1 ms) to SP waveform midpoint (SP). Waveform midpoint (SP) was measured from onset (O).

In stark contrast to the responses obtained using a 500 Hz stimulus, no oscillating patterns can be seen in the 2000 Hz traces. Instead, a notable positive amplitude shift from baseline is observed following the onset of the response. For all durations, as rate increases, the latency at which the waveform reaches peak amplitude also increases; with slower rates reaching peak amplitude at an earlier latency when compared to the higher

rates. Following this peak positive shift in waveform amplitude, a gradual decrease in amplitude occurs with increasing latency as the waveform returns to near baseline amplitude measures. While general amplitude trends were observed over the entirety of the waveform, only the amplitude at midpoint of the SP response was formally assessed. The SP amplitude results were assessed separately for the 500 Hz and 2000 Hz conditions. Table 2 displays means and standard deviations for the SP amplitudes across rate and duration for each frequency.

Table 2. Mean SP amplitudes for 500 Hz and 2000 Hz stimulus durations (standard deviations in parentheses)

Stimulus Rate/s	500 Hz			2000 Hz		
	12 ms	6 ms	3 ms	12 ms	6 ms	3 ms
7.1	-.067 (.09)	.016 (.09)	.051 (.13)	-.042 (.14)	.041 (.14)	.226 (.16)
19.53	-.107 (.14)	-.042 (.14)	.101 (.14)	.018 (.21)	.071 (.12)	.262 (.19)
58.59	.028 (.08)	.019 (.13)	.094 (.09)	.190 (.32)	.170 (.22)	.212 (.23)
97.99	--	.022 (.07)	.073 (.06)	--	.180 (.15)	.200 (.16)
234.38	--	--	.026 (.07)	--	--	.146 (.15)

Figures 10 and 11 depict the mean SP amplitude for the 500 Hz condition across rate and duration respectively. ANVOA results revealed statistically significant differences for main effect of rate, $F(2, 38) = 6.216, p < .05, \eta^2 = .246$, and duration, $F(2, 38) = 16.097, p < .001, \eta^2 = .459$. A significant rate and duration interaction, $F(4, 76) =$

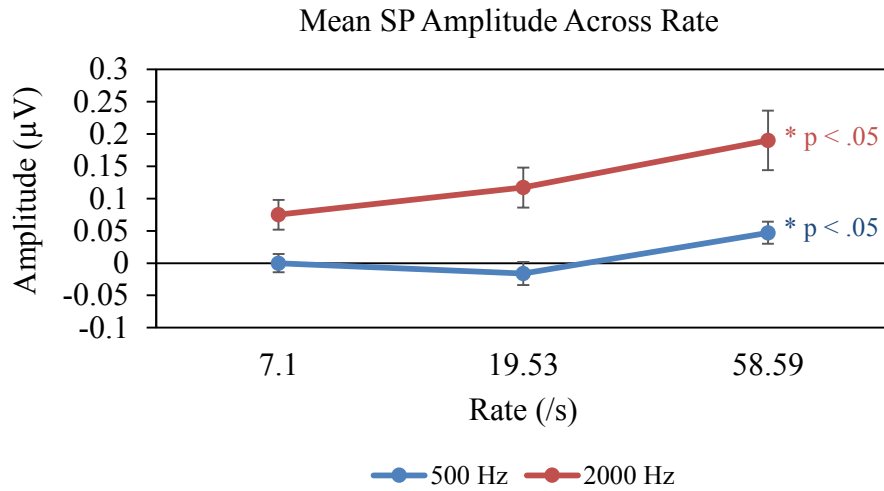

Figure 10. Mean SP amplitude values across three repetition rates (7.1/s, 19.53/s, and 58.59/s) for the 500 Hz condition (blue) and 2000 Hz condition (red). For both frequencies SP amplitude is significantly larger for the rate 58.59/s compared to rates 7.1/s and 19.53/s.

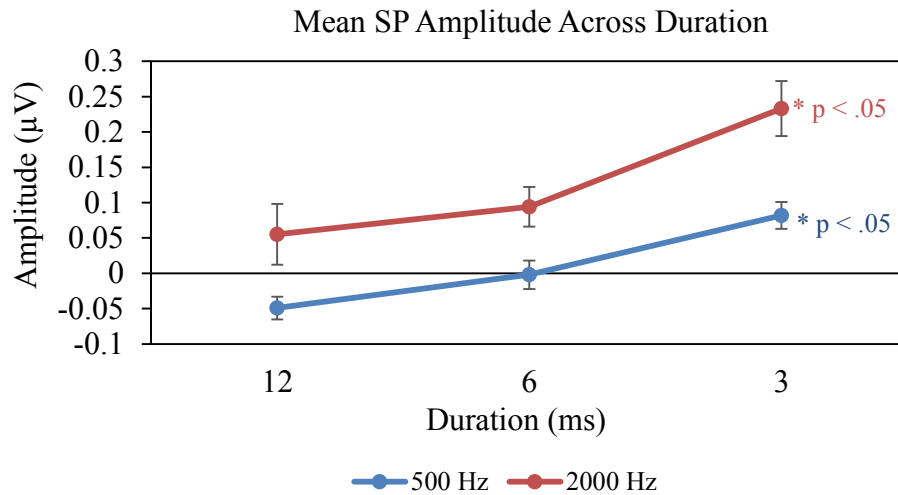

Figure 11. Mean SP amplitude values across three durations (12 ms, 6 ms, and 3 ms) for the 500 Hz condition (blue) and 2000 Hz condition (red). 500 Hz condition: SP amplitude is significantly different across all durations, with the largest SP amplitude for the 3 ms duration and the smallest SP amplitude for the 12 ms duration. 2000 Hz condition: SP amplitude is significantly larger for the 3 ms duration than for the 12 ms and 6 ms durations.

3.461, $p < .05$, $\eta^2 = .154$, was also found. The mean difference between SP amplitude as a function of rate is due to significantly larger SP amplitude ($p < .05$) at 58.59/s (mean = .047 μV) than that at rates 7.1/s (mean = .00 μV) and 19.53/s (mean = -.016 μV). No significant difference was found between mean SP amplitudes for the two slow rates (7.1/s and 19.53/s). The SP amplitude was significantly different ($p < .05$) between all durations (12 ms, 6 ms, and 3 ms). Mean SP amplitude increased with decreasing stimulus duration, in that the smallest mean SP amplitude was found for 12 ms duration and the largest for the 3 ms duration.

Figure 12 shows the mean SP amplitude for 500 Hz across rate and duration. Each stimulus duration was examined independently across rate to include all tested rates in the analysis. For the 12 ms duration recording, a statistically significant difference, $F(2, 38) = 9.74$, $p < .005$, $\eta^2 = .339$, occurred across rate. Post hoc pairwise comparison revealed significantly larger ($p < .05$) SP amplitude at 58.59/s (mean = .028 μV) compared to 7.1/s (mean = -.067 μV) and 19.53/s (mean = -.107 μV). No significant difference in SP amplitude was found between rates 7.1/s and 19.53/s ($p > .05$) for the 12 ms duration condition. Rate was also assessed independently for the 6 ms duration recordings, in order to include 97.66/s, and for the 3 ms duration recordings, in order to include 97.66/s and 234.38/s. For the 6 ms condition, there was no significant effect ($p > .05$) across rate. However, a statistically significant difference, $F(4, 76) = 2.499$, $p < .05$, $\eta^2 = .116$, was found for the SP amplitude across rate for the 3 ms condition. Post hoc pairwise comparison revealed that the significant difference ($p < .05$) between SP amplitude is due to significantly larger SP amplitude values for 58.59/s (mean = .095 μV) and 97.66/s (mean = .07 μV), compared to 234.38/s (mean = .026 μV).

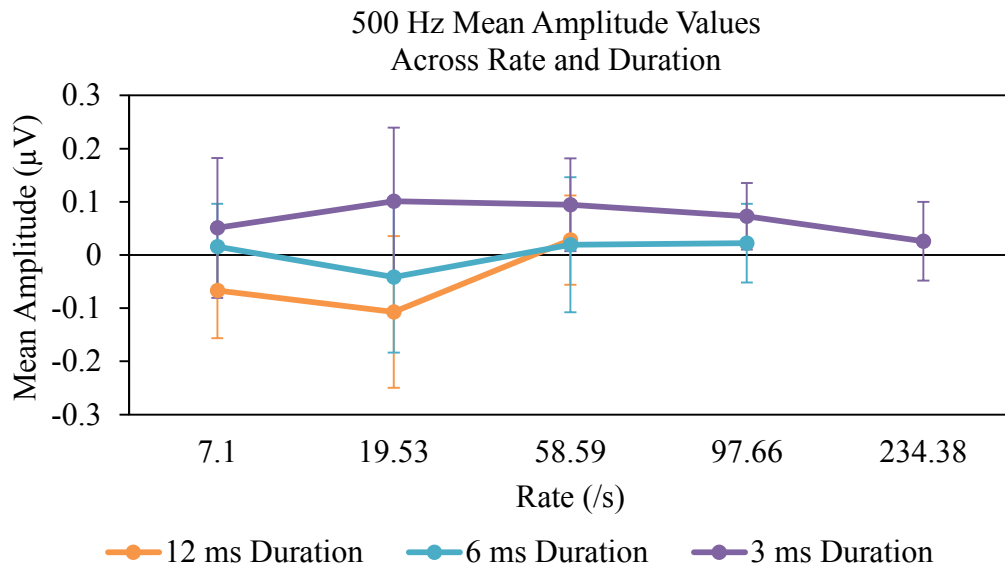

Figure 12. Mean SP amplitude values for the 12 ms duration (orange line), 6 ms duration (blue line), and 3 ms duration (purple line) as a function of repetition rate for the 500 Hz condition.

Figures 10 and 11 display the mean SP amplitude values for rate and duration, respectively. For the 2000 Hz condition, statistically significant differences were found for main effect of rate, $F(2, 38) = 6.774, p < .005, \eta^2 = .263$, and duration $F(2, 38) = 11.379, p < .001, \eta^2 = .375$. Findings also showed significant interaction between rate and duration, $F(4, 76) = 6.480, p < .001, \eta^2 = .254$. The mean difference between SP amplitude as a function of rate is due to significantly larger ($p < .05$) SP amplitude at 58.59/s rate (mean = .190 μV) than at 7.1/s (mean = .075 μV) and 19.53/s (mean = .117 μV) rates. No significant difference was found between mean SP amplitudes for 7.1/s and 19.53/s. The SP amplitude was found to be significantly larger ($p < .05$) for the 3 ms condition, when compared to the smaller mean amplitudes found for the 12 ms and 6 ms conditions. No statistically significant difference was noted between the 12 ms and 6 ms durations.

Figure 13 displays the mean SP amplitude values across rate and duration. An independent analysis of the 12 ms duration recording revealed a statistically significant difference, $F(2, 38) = 9.936, p < .005, \eta^2 = .343$, across rate. Significantly larger SP amplitude ($p < 0.05$) was found for 58.59/s (mean = .189 μV) compared to 7.1/s (mean = -.042) and 19.53 (mean = .018). No significant difference in SP amplitude was found between rates 7.1/s and 19.53/s ($p > .05$). In order to include the remaining rates, 97.66/s and 234.38/s, in the analysis, rate was assessed independently for the 6 ms and 3 ms conditions. The 6 ms duration condition revealed a statistically significant difference, $F(3, 57) = 6.009, p < .005, \eta^2 = .240$, between SP amplitude across rate. Specifically, a significant difference was found due to larger amplitude at rates 58.56/s (mean = .170 $\mu\text{V}; p < .05$) and 97.66/s (mean = .180 $\mu\text{V}; p < .005$), when compared to rate 7.1/s (mean = .042 μV). A significantly larger ($p < .005$) amplitude was also found for 97.66/s than for 19.53/s (mean = .071 μV). No other significant difference ($p > .05$) was observed between rates for the 6 ms duration. For the 3 ms condition, a statistically significant difference, $F(4, 76) = 3.384, p < .05, \eta^2 = .151$, was noted. Specifically, a significantly larger ($p < .05$) amplitude was found for 19.53/s (mean = .262 μV), than for the two highest rates assessed, 97.66/s (mean = .201 μV) and 234.38/s (mean = .146 μV). No other significant difference ($p > .05$) was found between rates for the 3 ms duration.

TM Electrode Placement and Audiometric Threshold

Audiometric thresholds were collected across three different test conditions: baseline, post TM electrode placement (in place), and post TM electrode removal (off place). As a criterion for participation in the study, baseline thresholds were required to

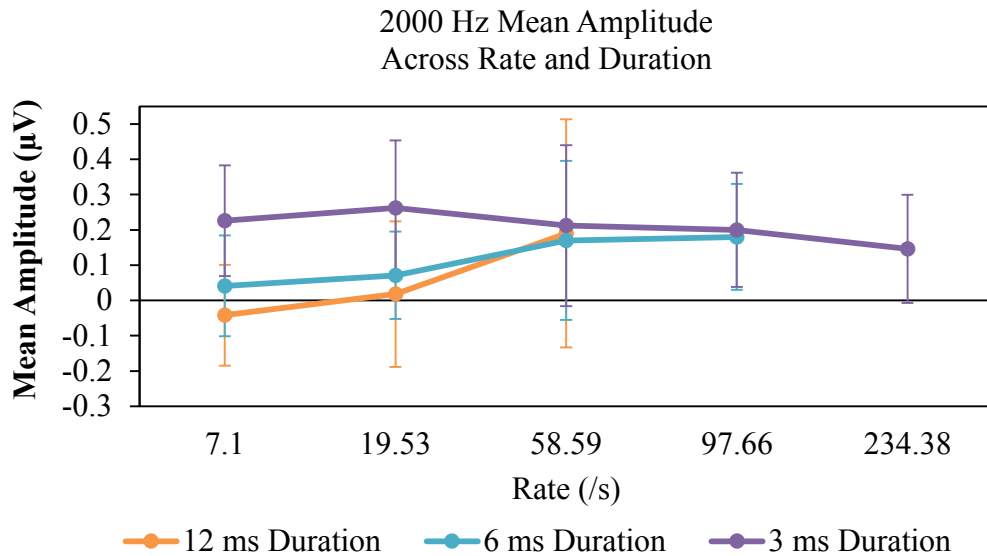

Figure 13. Mean SP amplitude values for the 12 ms duration (orange line), 6 ms duration (blue line), and 3 ms duration (purple line) as a function of repetition rate for the 2000 Hz condition.

be below 25 dB HL across all tested frequencies (250 Hz – 8000 Hz). The mean baseline thresholds ranged from a high of 10.75 dB HL at 250 Hz to a low of 1.75 dB HL at 4000 Hz. Post TM electrode placement, with the electrode situated on the participant’s TM, resulted in thresholds shift with mean low frequency thresholds increasing, and mid and high frequencies remaining relatively stable or improving from baseline. The range of mean thresholds for the post TM electrode placement (in place) condition was a high of 16.00 dB HL at 250 Hz and a low of 0.50 dB HL at 4000 Hz. Final threshold values were obtained post TM electrode removal (off place) and corresponded to a return to near baseline threshold measures. The mean threshold range for this off place condition was found to be a high of 9.75 dB HL at 250 Hz and a low of 1.50 dB HL at 4000 Hz. Throughout all conditions, 250 Hz was found to have the highest mean threshold, while 4000 Hz was found to have the lowest mean threshold. The mean thresholds of the four

other frequencies (500 Hz, 1000 Hz, 2000 Hz, and 8000 Hz) evaluated did not exceed 8.25 dB HL or fall lower than 6 dB HL across all tested conditions. Table 3 summarizes the means and standard deviations for the audiometric thresholds obtained for each test condition.

Table 3. Mean (standard deviation) hearing threshold values obtained for pre TM electrode placement (baseline), post TM electrode placement (in place), and post TM electrode removal (off place). N = 20 participants.

Frequency (Hz)	Baseline	In Place	Off Place
250	10.75 (5.68)	16.00 (7.88)	9.75 (5.73)
500	7.25 (3.02)	8.25 (3.35)	7.00 (3.77)
1000	7.75 (3.02)	7.25 (3.02)	7.75 (3.43)
2000	7.50 (4.44)	6.50 (3.28)	6.00 (3.84)
4000	1.75 (3.73)	.50 (3.20)	1.50 (4.01)
8000	6.25 (5.8)	6.00 (4.76)	7.25 (4.44)

Repeated measures ANOVA revealed statistically significant threshold differences across frequency, $F(5, 95) = 20.668, p < .005, \eta^2 = .521$, but no significant difference was observed for the three test condition alone, $F(2, 38) = 2.665, p > .05, \eta^2 = .123$. There was also a significant interaction between frequency and test condition, $F(10, 190) = 5.976, p < .005, \eta^2 = .239$. A significant difference in threshold ($p < .005$) was found when comparing both 250 Hz and 4000 Hz to all other tested frequencies. The 250 Hz threshold was significantly higher ($p < .005$) than all other frequencies, and the 4000 Hz threshold was significantly lower ($p < .005$) than all other frequencies. No significant threshold difference ($p > .05$) was found for the remaining frequencies: 500 Hz, 1000 Hz,

2000 Hz, and 8000 Hz. A two sample t-test was utilized to compare thresholds across test conditions for the lowest frequency evaluated, 250 Hz. A significantly higher threshold was obtained from the in place condition (mean = 16 μ V, SD = 7.881 μ V) compared to the baseline condition (mean = 10.75 μ V, SD = 5.684 μ V); $t(38) = 2.416, p < 0.05$; as well as compared to the off place condition (mean = 9.75 μ V, SD = 5.73 μ V); $t(38) = 2.869, p < 0.05$. No significant threshold difference was found between the baseline and off place conditions ($p > .05$). Figure 14 displays the mean audiometric thresholds obtain for each of the three test conditions: baseline, in place, and off place.

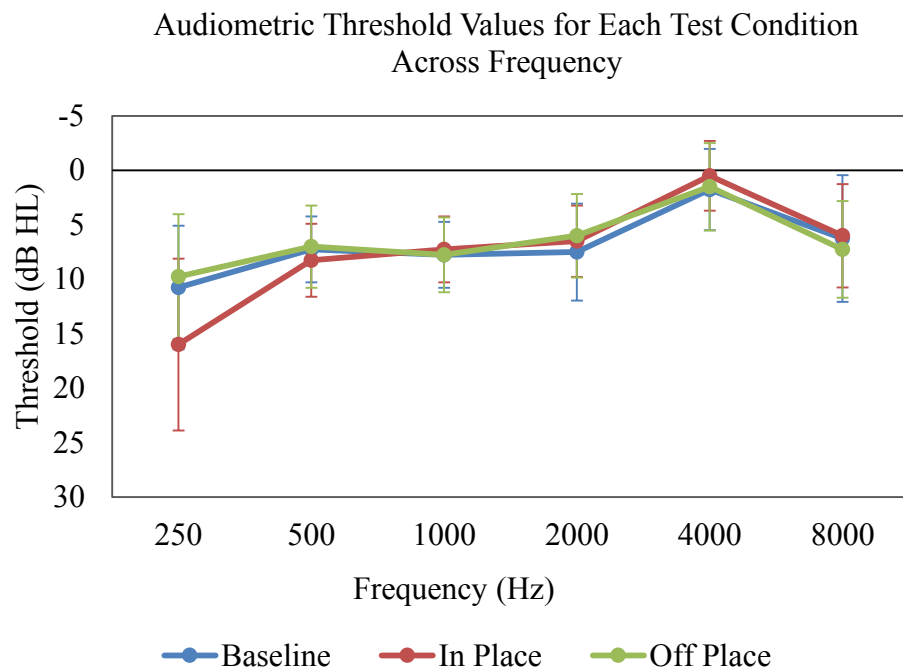

Figure 14. Mean audiometric threshold values across frequency for each of the three test conditions, baseline (blue line), in place (red line) and off place (green line). Significant differences ($p < .005$) in threshold were found for both 250 Hz (higher threshold) and 4000 Hz (lower threshold) when compared to all other tested frequencies.

DISCUSSION

The primary objective of this research was to obtain normative SP amplitude data to 500 Hz and 2000 Hz tone burst ET ECoChG using CLAD in for adult females with normal hearing sensitivity. The use of ECoChG in the assessment of the auditory system has garnered a great deal of evaluation in terms of protocol, parameters, and methodology. While TT tone burst ECoChG has been routinely evaluated for its potential usefulness in objectively measuring the presence of Ménière's disease/endolymphatic hydrops (Conlon & Gibson, 2000; Ferraro & Krishnan, 1997; Gibson, 1993, 2009; Iseli & Gibson, 2010; Wuyts, Van De Heyning, Van Spaendonck, & Molenberghs, 1997), fewer studies have examined tone burst ECoChG using ET measurements at slow repetition rates (Ferraro et al., 1994a; Levine et al., 1992; Margolis et al., 1995). This study is a novel assessment of tone burst ET ECoChG with CLAD employed to assess SP amplitude at high repetition rate. Normative data was obtained across frequency, rate, and stimulus duration in order to determine how specific stimulus parameters affect the SP amplitude and to determine feasibility for future studies evaluating ECoChG to high rates in clinical populations, such as individuals with Ménière's disease.

As an ET recording site was used in the collection of the electrocochleograms, a secondary objective was added in order to examine the effect of TM electrode placement on audiometric thresholds. This objective offers a relevant addition to the current body of literature evaluating the effect of electrode placement on the TM (Smith et al., 2016; Stypulkowski & Staller, 1987).

SP Amplitude Data

For the two frequencies analyzed, SP were recorded and evaluated to three rates, 7.1/s, 19.53/s, and 59.59/s, for each of the three stimulus durations, 12 ms, 6 ms and 3 ms. Also, SP were evaluated to another two higher rates (97.66/s and 234.38/s) for the 6 ms and 3 ms duration. It is expected that the recorded SP remains present within the recording for the duration of the evoking stimulus. Results showed distinct SP amplitude trends across repetition rate and across stimulus duration for both the 500 Hz and 2000 Hz conditions. Data revealed significantly larger SP amplitude for the highest repetition rate, 58.59/s, compared to the slower rates, 7.1/s and 19.53/s, and for the shortest duration, 3 ms, compared to longer duration stimuli, 12 ms and 6 ms. Though data was not compared across the 500 Hz and 2000 Hz conditions, mean SP amplitude values were also found to be larger for 2000 Hz than 500 Hz across rate and duration.

Overall, the use of longer duration stimuli (12 ms and 6 ms) corresponded to mean SP amplitude growth with increasing repetition rate. However, this trend was reversed with the use of short duration stimuli (3 ms), in which mean SP amplitude to 3 ms duration decreased as repetition rate increased. Although mean SP amplitude was larger across all rates for the 3 ms duration condition, the decrease in SP amplitude as rate increased was not consistent with a previous report by Wuyts et al. (2001) who demonstrated the opposite trend with increasing rate; nor with the results of the 6 ms and 12 ms duration conditions in this study. As significant differences between the results obtained using long or short stimulus durations exist, further discussion addresses each independently in order to more deeply examine the relation between rate, duration, and SP amplitude.

Long Duration Tone Burst Stimuli. The majority of studies examining ET, tone burst ECoChG utilize long duration tone burst stimuli to examine the SP (Al-momani et al., 2009; Ferraro et al., 1994a; Levine et al., 1992; Margolis et al., 1995). Under ideal conditions the SP will remain present within the recording for duration of the evoking stimulus, as such the use of long duration is typically applied when the SP is the potential of interest. In the present study, two long duration stimuli were used, 12 ms and 6 ms, across three (7.1/s, 19.53/s, and 58.59/s) and four (7.1/s, 19.53/s, 58.59/s, and 97.66/s) repetition rates, respectively.

Slow Repetition Rate. The mean SP amplitude for the long duration (12 ms) and slow rate (7.1/s) had negative amplitude values, with $-0.067 \mu\text{V}$ at 500 Hz and $-0.042 \mu\text{V}$ at 2000 Hz. The direct comparison of the current SP amplitude results to previously published research is difficult due to distinct differences in recording and stimulus parameters, as well as limited published reports examining normative SP amplitude to tone burst using ET ECoChG recording (Wuyts et al., 1997). Wuyts et al. (1997) performed a meta-analysis examining ET and TT, click and tone burst ECoChG data obtained from the literature, and noted that too few reports exist for ET, tone burst ECoChG to extract normative tone burst SP amplitude data. However, the meta-analysis revealed a trend of normative SP amplitude values that occur close to baseline levels or have a slightly positive value. For the current study, non-inverting and inverting electrodes are reversed and SP peaks up, with this taken into account, the Wuyts et al. (1997) report closely matches the results of the current study which finds SP amplitude values near baseline or of slightly negative value.

These findings are mirrored in the normative SP amplitude data collected by Ferraro et al. (1994a). Though clear parameter differences exist, including stimulus intensity (90 dB nHL), rate (11.3/s), and duration (2-10-2), their findings can be used for the purposes of broad comparison of SP amplitude trends in a normative population, using slow rate, long duration tone burst ECochG. Ferraro et al. (1994a) reported mean SP amplitude values of 0.19 μV for 500 Hz and 0.08 μV for 2000 Hz. Again, electrode montage accounts for differences between the recordings; with reversed positive and negative values these SP amplitude values are consistent with our SP amplitude results for both frequencies.

While our results are similar to the Ferraro et al. (1994a) study, other reports utilizing long duration tone bursts (15 ms) with slow rate (13/s) have obtained larger, positive SP amplitude values in subjects without inner ear disease (Levine et al., 1992; Margolis et al., 1995). Margolis et al. (1995) examined 2000 Hz tone burst, ET ECochG in adults with normal hearing, at two intensity levels, 100 dB SPL and 110 dB SPL and found mean SP amplitude results of .65 μV and .96 μV , respectively. These results are significantly larger than the results obtained in this study, even when compared to the most positive values obtained for both the 7.1/s and 19.53/s conditions. Numerous recording and stimulus parameters exist between the studies, likely contributing the differences between SP amplitude results. In the present study, we recorded SP at higher repetition rate, shorter stimulus duration, and perhaps most importantly lower stimulus intensity. Reports have showed the SP is better elicited at higher intensity levels (Ferraro & Durrant, 2006; Margolis et al., 1995; Wuyts et al., 1997). Due to the long length of testing in the current study, very high intensity was avoided and a stimulus level of 75 dB

nHL (107 dB SPL) was employed in order to maintain patient comfort throughout the evaluation. This level is at least 5 dB below the recommended level for optimal recording of ECoChG response (Wuyts et al., 1997); which may have led to a reduced SP amplitude across test conditions. Other differences which may account for the larger normative SP amplitude values include TM electrode design as well as the use of direct microscope visualization for uniform electrode placement on the umbo. Margolis et al. (1995) suggested that the placement of the electrode on the umbo was a primary factor in the collection of larger SP amplitudes compared to previous research. In the current study, placement on the TM was verified using standard otoscopy, patient report of contact, and impedance measures; exact location of electrode placement on the TM was not recorded. While a recent report by Alhanada (2012), suggests no statistical or clinical difference occurred with variation in electrode location on the TM on SP/AP amplitude ratio, individual SP and AP amplitude values with differing electrode location were not included in the study and future research regarding the impact of electrode placement is warranted.

For the 500 Hz condition the use of slow repetition rate is limited by the possible contribution of neural generators. As shown in Figure 7, a specific oscillating pattern was noted in the recording across the slower rates, 7.1/s and 19.53/s, and long durations, The SP oscillation results to 500 Hz tone are consistent with the contribution of neural excitation that is phase locked to this low frequency stimulus (Lichtenhan, Cooper, & Guinan 2013; Lichtenhan, Hartsock, Gill, Guinan, & Salt, 2014; Chertoff, Kamerer, Peppi, & Lichtenhan, 2015). This finding is similar to that obtained by Ferraro et al. (1994a), who, when using a 500 tone bursts stimuli, reported that these waves may be

phase-locked AP components. Oscillations decreased with increasing stimulus repetition rate, further supporting the interpretation of the neural origin of this waveform component, as auditory nerve fibers do not respond to high-rate stimuli while in their refractory period (Wilson & Bowker, 2002). It is possible that the oscillations occurring in the slow rate, long duration 500 Hz recordings are contributing to the mean SP amplitude results, as the neural component is being measured along with the SP response. SP amplitude was measured from one pre-defined midpoint along the waveform for all rates and participants and the measurements did not take into account variations associated with the peaks and troughs of the oscillations. As SP amplitudes collected were small, the differences these oscillations may have made in individual recordings may have had a significant impact on the collected amplitude data. For example, the midpoint occurring at a peak of the oscillation for one recording and at a trough for another had the potential to influence the SP amplitude values obtained.

A possible technique to reduce the contribution of the oscillations within the 500 Hz recordings is to utilize a spectral filter with a low-pass frequency cut-off to remove the residual stimulus artifact. Using the Intelligent Hearing Systems software, spectral band pass filtering was applied offline to one of the traces to evaluate this method as an alternative processing technique in the examination of the 500 Hz recordings. Figure 15 displays this technique for a 12 ms, 58.59/s deconvolved trace across four spectral filters: 0-250 Hz, 0-300 Hz, 0-350 Hz and 0-450 Hz. As is depicted in the figure, the more filtering the smoother the resultant waveform. The labelled SP indicates the pre-defined midpoint for the 12 ms stimulus duration. No further analysis of this technique was made, and the data was not re-calculated using the spectral filtering, however, the successful

application of the filtering suggests its possible use in reducing artifact and allowing for better detection of the SP in the response.

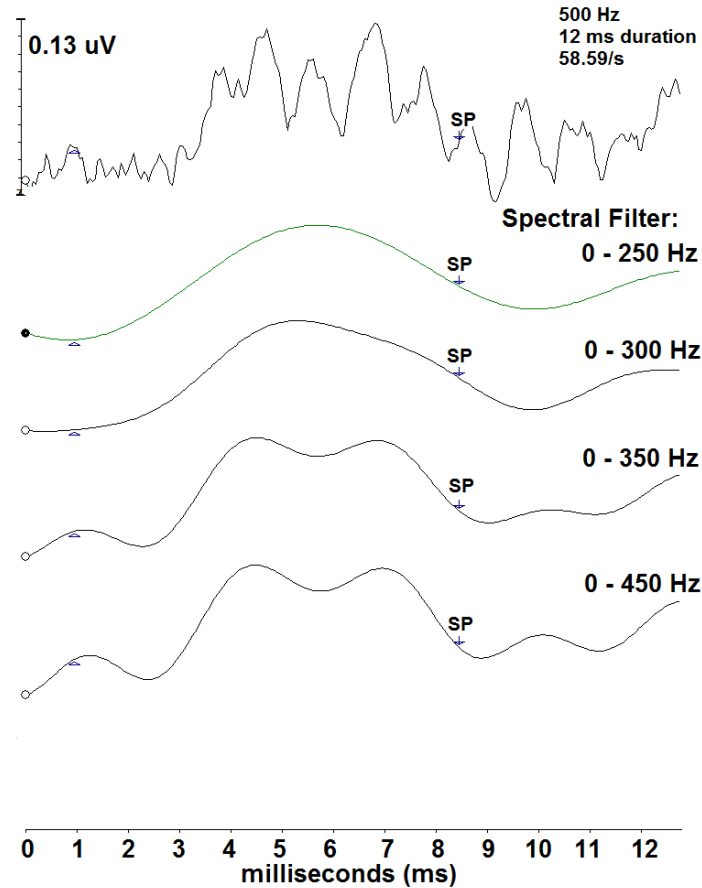

Figure 15. Spectral filtering of a CLAD deconvolved tone burst ECochG waveform (top) from one of the participants (P12) for the 500 Hz, 12 ms, 58.59/s condition. Displayed in descending order, four spectral band pass filters were applied: 0-250 Hz, 0-300 Hz, 0-350 Hz, and 0-450 Hz. SP indicates the pre-defined midpoint of the 12 ms duration.

High Repetition Rate. The mean negative SP values obtained using slow rate and 12 ms stimulus duration are in contrast to the positive values obtained with higher rates (58.59/s). At higher rate (58.59/s), our findings for the long duration (12 ms) conditions revealed significantly larger SP amplitude compared to slower rates, 7.1/s and 19.53/s, at both frequencies.

With the application of high rate, the oscillations observed in the recordings for the 500 Hz conditions were no longer apparent and for the 12 ms condition a significantly larger mean SP amplitude of .028 μV was recorded at 58.59/s. However, no significant amplitude changes were found for 500 Hz across rate for the 6 ms condition. Despite this limitation and the possible contribution of neural generators at slow rate, benefits of the evaluation of this frequency remain as low frequency, tone burst ECoChG provides a useful method of examining the apical turn of the cochlea, which remains especially important in the assessment of early Ménière's disease. These results also suggest the use of long duration stimuli (12 ms) with a high repetition rate to examine the SP at 500 Hz.

The use of 2000 Hz tone burst stimuli demonstrates the trend of increased SP amplitude observed with increasing repetition rate reported in the literature. Our findings reveal significantly larger SP amplitude with the highest rate, 58.59/s, compared to the slowest rate 7.1/s for the 12 ms condition and statistically significant SP amplitude growth when comparing the slower rates, 7.1/s and 19.53/s, to the higher rates, 58.59/s and 97.66/s, for the 6 ms duration condition. These findings are consistent with previous examination of SP amplitude at high rates. Wilson and Bowker (2002), for example, studied click ECoChG using ET recording to 7.1/s to 151.1/s click rates without the CLAD technique. They reported increase in the SP amplitude with high rates. However, the SP amplitude was reduced overall due to two main factors. First, the poor frequency specification due to the use of click stimuli, which would worsen due to the complexity of the waveform morphology with increasing repetition rate (Wilson & Bowker, 2002). Second, without the use of CLAD technique, recording at high rates results in poor morphology and overlapping of the response due to physiological neural dyssynchrony.

These findings highlight not only the usefulness of tone burst stimuli in the examination of the SP, but also the value of CLAD in the deconvolution of waveforms at high rate.

In another study, Wuyts et al. (2001) record tone burst ECoChG using TT recording. They also reported significant increase in SP amplitude values when rate was increased from 8.4/s to 37.4/s. However, direct comparison of SP amplitudes between our study and their study is impossible, because of recording and parameter differences, especially as a TT recording method was utilized by Wuyts et al. (2001). The literature suggests that ET amplitude values will be approximately 4 – 10 times smaller than results obtained using a TT recording method as better signal to noise conditions occur with the near-field placement of the electrode on the promontory allowing for close proximity to the cochlear generators (Ferraro & Krishnan, 1997; Ferraro et al., 1994b; Haapaniemi et al., 2000; Wuyts et al., 1997).

Though the ET SP amplitude values of the current study cannot be examined in reference to the results obtained by Wuyts et al. (2001), the underlying mechanisms responsible for the increase in SP amplitude are likely comparable between the studies. It is suggested that the increase in SP amplitude is associated with the displacement of the basilar membrane in response to the increasing repetition rate. As rate increases the basilar membrane does not return to baseline position prior to the onset of the next stimulus, causing an increase in the non-linearity along the basilar membrane and resulting asymmetry creates a larger direct current, or SP response (Wuyts et al., 2001). While this explanation of SP amplitude generation remains only a theory, the results of the current study do support the findings that SP amplitude increases with increased rate.

Based on these findings, it is recommended to use high rates and long duration tone bursts to record SP.

Short Duration Tone Burst Stimuli. Significant differences in SP amplitude trends exist between long and short duration stimuli. With the use of the shortest duration stimulus, 3 ms, SP amplitudes peaked at 19.53/s, with subsequent decrease as repetition rate increased to the highest rate evaluated, 234.38/s. This trend was observed for both the 500 Hz and 2000 Hz frequencies with significantly smaller SP amplitude found for 234.38/s compared to 58.59/s and 97.66/s for 500 Hz and with the 234.38/s and 97.66/s compared to 19.59/s for 2000 Hz. In order to address the overall decrease in SP amplitude to high rates, the contribution of neural responses recorded with the use of 3 ms stimulus durations must be explained.

As the SP response was the potential of interest, the AP response was not formally addressed within the current research; however, its presence is evident in the 3 ms recordings and is likely the primary factor behind the opposite SP amplitude trend observed for the 3 ms duration condition when compared to the SP amplitudes obtained using longer duration stimuli. Though the AP is present within the 12 ms and 6 ms duration conditions as well, the measurement of the SP amplitude at the midpoint, 6 ms and 3 ms after the onset of the response, respectively, reduces the neural contribution within the results. However, the use of a 3 ms duration stimulus necessitates the collection of the SP amplitude earlier in the recording (1.5 ms after the onset of the response), where the AP is still dominating the response. Thus, it is likely that the SP amplitudes recorded under the 3 ms duration condition in the present study do not truly reflect the SP alone and are more representative of the AP contributing to the response.

In addition to the direct visualization of the AP, the decrease in amplitude observed with increasing repetition rate also suggests significant contribution of the AP in the recording. Several reports note overall SP stability with repetition rate possibly due to the pre-neural nature of this receptor potential and the non-linearity occurring on the basilar membrane (Bextermueller, 2015; Bohorquez, Morawski, Ozdamar, & Niemczyk, 2006; Dixon, 2015; Kaf et al., 2017; Wilson & Bowker, 2002; Wuyts et al., 2001). However, AP amplitude reduction and latency increase has been clearly demonstrated in the literature as repetition rate is increased (Bextermueller, 2015; Bohorquez et al., 2006; Dixon, 2015; Kaf et al., 2017; Wilson & Bowker, 2002). Kaf et al. (2017) described this AP adaptation in response to click stimuli with high repetition rates exceeding 500/s, and using CLAD, and found a significant AP amplitude decrease with increasing repetition rate. This finding is thought to be associated with the physiologic neural adaptation and dyssynchrony occurring in the auditory nerve to high repetition rate. The contribution of the AP response in the recording has also been identified using high rate, tone burst ET ECoChG. Gibbin et al. (1981) utilized a 4000 Hz tone burst presented at a rate of 200 tone bursts/s in the evaluation of the SP amplitude in patients with Ménière's disease prior to and following glycerol injection. This 200/s rate was selected in order to cause adaptation of the AP in the recording (Gibbin et al. 1981). Gibbin et al. (1981) note that the measurement of the SP amplitude was difficult as the AP did not fully adapt and was still present within the recording. This is consistent with the short duration, fast repetition rate findings in our study which show contribution of the AP within the response, despite evidence of adaptation.

As the AP is rarely the potential of interest when utilizing tone burst ECoChG measures, many researchers have actively attempted to reduce its contribution through the use of long duration, long onset tone burst stimuli. Limited reports of AP behavior exist beyond notes of its presence being eliminated or reduced in the recording (Levine et al., 1992; Margolis et al., 1995). As a 3 ms tone burst stimulus, with short 1.5 ms rise/fall time and no plateau, was utilized to elicit a response, the presence of the AP within the recording was not unexpected. The collection of the AP requires synchronous neural firings, best obtained using click stimuli or frequency specific stimuli with short onsets (Ferraro & Durrant, 2006; Lichtenhan et al., 2013).

Few reports of tone burst, ET ECoChG performed with stimulus duration less than 7 ms were found in the literature. This is likely due to the inherent advantages of long duration stimuli for recording of the SP without the contribution from neural generators (Ferraro et al., 1994a). However, for the purposes of this study it was pertinent to utilize shorter duration tone bursts as the use of high repetition rate was a key point of examination. In order to increase repetition rate, stimulus duration must be shortened to avoid stimulus overlap within the signal. This limits the ability to assess tone burst ECoChG to the very high repetitions (507/s) possible with the use of click stimuli (Kaf et al., 2017). As tone burst SP amplitude decrease was observed with increasing stimulus rate, our findings show that SP was obscured by the AP response when recording using 3 ms tone burst duration and 234/s fast rate. Based on our findings, further evaluation is warranted to determine the highest rate and shortest stimulus duration possible to limit the contribution of the AP and prevent overlap of the eliciting stimulus.

High Repetition Rate and Continuous Loop Averaging Deconvolution

The use of high rate in AEP measures, including ECochG, faces limitations as rate increases to the point where the waveforms overlap within the recording, obscuring the response of interest. As such it was necessary to employ the CLAD technique, to unwrap or deconvolve the waveforms in order to analyze and interpret the ECochG responses obtained at higher rates. The use of CLAD with tone burst ECochG was successfully demonstrated in this study. Several studies have documented the successful employment of CLAD in ECochG, however these studies have focused on the use of click stimuli, likely due to the ability to present clicks at very fast rates and analyze the recorded ECochG response (Bextermueller, 2015; Dixon, 2015; Kaf et al., 2017; Bohorquez et al., 2006; Bohorquez et al., 2009). As previously discussed, the use of very high repetition rate with tone burst stimuli is impossible due to inherent stimulus overlap that would occur within the signal. However, waveforms obtained using rates up to 234.38/s were successfully deconvolved allowing for clear observation of the SP and the AP within the recordings. This novel finding supports the use of CLAD with responses evoked using tone burst stimuli. With close monitoring of the maximum repetition rate in the CLAD sequence, CLAD can be applied to test SP amplitudes at high rates which were previously limited due to the overlap occurring within the waveform.

Audiometric Threshold Data

Audiometric threshold data was obtained across all participants over the three different test conditions, pre TM electrode placement (baseline), post TM electrode placement (in place), and post TM electrode removal (off place), from 250 Hz to 8000

Hz. Baseline measures were used to ensure hearing sensitivity ≤ 25 dB HL to meet requirements for participation in the current study. The participant mean baseline threshold data compared well to previous normative threshold population studies. Lutman and Davis (1994) screened 241 male and female participants ages 18 – 30, and obtained a mean threshold range from 4.1 dB HL occurring at 1000 Hz to 15.4 dB HL at 6000 Hz. While our research saw the lowest threshold occur at 1.75 dB HL for 4000 Hz and the highest, 10.75 dB HL, at 250 Hz, these results still fall within the 25th and 75th percentiles put forth by Lutman and Davis (1994), respectively. Valiente, Fidalgo, Berrocal, and Camacho (2015) screened 138 female participants ages 15 – 34 and again, our mean threshold findings fall within the 25th to 75th percentiles across all tested frequencies.

When examining results across the three test condition, a statistically significant threshold increase with TM electrode placement (in place) occurred for 250 Hz, which returned to mean baseline levels following the removal of the electrode (off place). Smith et al. (2016) undertook a similar examination of threshold change with TM electrode placement and found significant increase in threshold compared to baseline measures for 250 Hz, 500 Hz, and 8000 Hz. The authors observed the largest increase of 7.5 dB at 250 Hz, and smaller increases of 4.2 dB at 500 Hz and 3.89 dB at 8000 Hz. The threshold data in the current study did not reflect the same changes observed by Smith et al. (2016) for 500 Hz and 8000 Hz tones, but did show a mean increase of 5.25 dB at 250 Hz. Smith et al. (2016) suggest that these shifts in threshold with electrode placement are associated with the pressure and mass of the electrode against the TM causing a change in transmission characteristics of the middle ear system that is conductive in nature. Though no bone condition testing was performed with the electrode in place in either the Smith et

al. (2016) report or the present study, the addition of a third condition (off place) in this study which resulted in thresholds returning to baseline levels following removal of the electrode does further support the likelihood of a temporary conductive component associated with the increase of the thresholds when the electrode is in place.

Interestingly, slight improvement in threshold compared to baseline measures was found with the electrode in place on the TM from 1000 Hz to 8000 Hz, with the largest improvement of 1.25 dB found at 4000 Hz. Though the results were not statistically significant, this finding does correspond with Smith et al.'s (2016) report that for some patients, improvement in thresholds occurred with TM electrode placement, though the authors did not specify which frequencies or by how much. One possible explanation for the slight threshold improvement with electrode placement is that the same mass and pressure changes that result with the placement of the TM electrode that are thought to be responsible for the increase of thresholds in the lowest and highest frequencies, may also account for the slight decrease in threshold observed with placement. Murakami, Gyo, and Goode (1997) measured decibel changes in response to pressure changes on the middle ear conduction system. The authors reported that both negative and positive pressure changes cause poorer middle ear function at frequencies below 1500 Hz, while improvement in middle ear function was observed at higher frequencies, especially with negative middle ear pressure. Though direct comparison to this study is problematic, as different mechanisms were used to achieve pressure differentials, Murakami et al. (1997) did demonstrate, as would be expected, the impact of middle ear function to negative and positive pressure. The placement of the electrode on the TM likely results in pressure

changes within the middle ear space and may impact how the signal is transmitted through the auditory pathway leading to frequency specific threshold changes.

Limitations of the Study

One of the most evident limitations to the current study is that these results cannot be generalized outside of the specific recording, participant, and analysis parameters used in the study. Currently, there are no standardized tone burst ECoChG parameters commonly used across research institutions, making direct comparison from one study to another impossible.

As both the 500 Hz frequency and the 3 ms durations responses contained contribution from the AP in the response it is difficult to ensure the measured SP amplitude is a true representation of that potential alone. The likely presence of the AP in the recording, whether it occurred as the onset response in the 3 ms duration conditions, or as oscillations throughout the waveform with the use of long duration, 500 Hz tone burst stimuli, its potential to significantly impact the results cannot be overlooked. As such, these SP amplitude results from these conditions are limited, though these findings do offer important insight into stimulus parameters with the use of 500 Hz stimuli in ET, CLAD ECoChG and the limitation of short duration tone burst stimuli when the SP is the potential of interest.

Another potential limitation can be associated with the method of SP amplitude measurement. The SP amplitude mid-point was fixed for each duration based on fixed waveform onset, making the SP amplitude measurement uniform across participants. While this uniform method of measurement allowed for the application of consistent

measurement parameters, it was observed during waveform labeling that the onset of the responses did vary between participants. While onsets of 2.5 ms for the 500 Hz condition and 1.5 ms for the 2000 Hz condition were chosen as they best approximated the onset of the responses, individual differences were observed across participants. As the onset was used as the point from which mid-point was measured, SP amplitude results may have slight variations if true onset was marked for each participant and measurements were made from that point in the responses. In the future, the SP waveforms obtained could be reassessed and examined with exact midpoints evaluated based response onset to determine possible differences between the measurement methods.

A limitation in the collection of audiometric threshold data with the placement of a TM electrode is the application of pure tone air conduction threshold examination alone. Though the change in thresholds with electrode placement is thought to be conductive in nature, especially as thresholds return to baseline levels with the removal of the electrode, this was not confirmed with the use of bone conduction testing. The addition of bone conduction audiometry across all test conditions would help to confirm the conductive nature of the pure tone air conduction threshold change with the electrode in place on the TM, as bone conduction thresholds should not be impacted.

Future Studies

The current study examined tone burst ECoChG with CLAD in a population group free of otologic pathology. The collection of normative data offers the ability for comparison of these results to individuals with Ménière's disease. Future research may utilize tone burst ECoChG with CLAD in participants with inner ear disorder in order to

better understand the relationship between the SP and increasing repetition rate in these groups. For example, Wuyts et al. (2001) found that with 1000 Hz, tone burst TT ECoChG, increasing repetition rate results in a larger SP amplitude for participants with Ménière's disease than those without the disease. This finding supports the potential benefit of higher repetition rates with this population and highlights the technique as a possible diagnostic measure for Ménière's disease. Future research to assess the specificity and sensitivity of tone burst, CLAD ECoChG in determining the presence or absence of Ménière's disease is warranted in attempts to improve the objective diagnosis of the condition.

With differences found between audiometric threshold data obtained between test conditions, future research evaluating the possible effect on TM electrode placement is warranted. Though Alhanada (2012) found no difference between SP/AP amplitude and area ratios and the electrode locations on the TM, no information regarding the possible effect on individual potential amplitudes was reported. The change in low frequency threshold (500 Hz) highlights the need for evaluation of the effect of TM electrode placement not only on thresholds, but also the ECoChG response. The evaluation of possible differences found between types of TM electrodes utilized may also offer valuable information to researchers and clinicians using TM recording sites.

CONCLUSION

This study was designed to assess the effect of repetition rate and stimulus duration on tone burst, ET ECoChG with the use of CLAD. The primary objective was to obtain normative SP amplitude data as a function of repetition rates, stimulus durations, and stimulus frequencies, 500 Hz and 2000 Hz. As a secondary objective, the effect of TM electrode placement was examined and audiometric thresholds were collected to determine the potential impact of the TM electrode on the auditory pathway. Twenty female participants between the ages of 20 and 35 with normal hearing sensitivity participated in this study. Tone burst, ET ECoChG measurements were made across five repetition rates, 7.1/s, 19.53/s, 58.59/s, 97.66/s, and 234.38/s, and three stimulus durations, 12 ms, 6 ms, and 3 ms, for 500 Hz and 2000 Hz frequencies. For rates at and above 19.53/s, CLAD was employed to deconvolve the overlapped waveforms obtained with increasing rate; allowing for higher rates to be successfully analyzed and interpreted. Prior to and following the tone burst ECoChG measurements, audiometric thresholds were collected for three test conditions, a baseline measure before electrode placement, with the electrode in place, and following the removal of the electrode.

The tone burst ECoChG evaluation revealed several important findings across rate and duration, as well as provided SP amplitude normative data for tone burst, ET CLAD ECoChG. For the 2000 Hz, long duration stimulus conditions, SP amplitude increased with increasing repetition rate. This finding supports the use of high rates for the collection of more robust SP amplitudes when 2000 Hz tone burst stimuli is used to elicit the response. For 500 Hz, the application of the longest stimulus duration (12 ms) with

the highest rate (58.59/s) also elicited larger SP amplitudes and limited the possible contribution of neural generators in the recording which were observed with slower rates. These findings also suggest the use of high repetition rate when examining the SP at 500 Hz. The use of the shortest stimulus duration (3 ms) examined revealed significant AP contribution in the recorded waveform. These findings may limit the ability to identify the amplitudes collected under this condition as the SP alone, and as such limit the usefulness of short stimulus duration, with any rate, to obtain SP response without neural contribution.

The audiometric threshold data did reveal a significant difference between 250 Hz thresholds and the thresholds across all other tested frequencies (500 Hz – 8000 Hz). A difference was also noted at 250 Hz between baseline thresholds and thresholds with TM electrode in place. This suggests a possible impact on low frequency hearing sensitivity when the TM electrode is applied, as following the removal thresholds returned to near baseline levels.

The study also demonstrates the successful recording of tone burst ECoChG to high rates with CLAD. While the use of tone burst stimuli limited the stimulus rate in this study to 234.38/s, the successful deconvolution of waveforms does support the application of CLAD with frequency specific stimuli. Overall, this research provided valuable information to the literature regarding the use of ET, tone burst ECoChG with CLAD across several rates, durations, and frequencies. The normative frequency specific SP amplitude data may be useful in diagnosing Ménière's disease that mainly affects low frequency early in the disease process. The effect of TM electrode placement on low

frequency threshold also highlights the importance of future research examining the potential impact on ECoChG using an ET recordings site.

REFERENCES

- Abramovich, S. (2013). *Electric Response Audiometry in Clinical Practice*. New York: Churchill Livingstone.
- Alhanada, M. (2012). *Electrocochleographic recordings from the eardrum: Variation and effects of electrode location in normal subjects* (Doctoral dissertation). Retrieved from <https://kuscholarworks.ku.edu/>
- Al-momani, M.O., Ferraro, J.A., Gajewski, B.J. & Ator, G. (2009). Improved sensitivity of electrocochleography in the diagnosis of Ménière's disease. *International Journal of Audiology*, 48, 811-819. doi: 10.3109/14992020903019338
- American Speech-Language-Hearing Association. (1988). *Tympanometry* [Relevant Paper]. Available from www.asha.org/policy.
- Baba, A., Takasaki, K. Tanaka, F., Tsukasaki, N., Kumagami, H., & Takahashi, H. (2009). Amplitude and area ratios of summating potential/action potential (SP/AP) in Ménière's disease. *Acta Oto-Laryngologica*, 129, 25-29.
- Bextermueller, K. (2015). *Electrocochleography and auditory brainstem response in normal adults and vestibular migraine patients using continuous loop averaging deconvolution* (Doctoral thesis). Missouri State University, Springfield.
- Bohorquez, J., Morawski, K., Ozdamar, O., & Niemczyk, K. (2006). High rate transtympanic electrocochleography in Meniere's patients using continuous loop averaging deconvolution (CLAD). Poster presentation. Retrived January 30, 2016 from <https://umshare.miami.edu/web/wda/engineeringfiles/BME/bohorquez.pdf>
- Bohorquez, J., Ozdamar, O, McNeer, R., & Morawski, K. (2009). Clinical application of evoked potential continuous loop averaging deconvolution (CLAD). In A. McGoron, C. Li, & W.-C. Lin (Eds.), *25th Southern Biomedical Engineering Conference 2009, IFMBE Proceedings*, 24, 133-134.
- Committee on Hearing and Equilibrium. (1995). Committee on hearing and equilibrium guidelines for the diagnosis and evaluation of therapy in Ménière's disease. *Otolaryngology – Head and Neck Surgery*, 113(3), 181-185.
- Conlon, B.J., & Gibson, W.P.R. (2000). Electrocochleography in the diagnosis of Ménière's disease. *Acta Oto-Laryngologica*, 120, 480-483.
- Chertoff, M.E., Kamerer, A.M., Peppi, M., & Lichtenhan, J.T. (2015). An analysis of cochlear response harmonics: Contribution of neural excitation. *Journal of the Acoustical Society of America*, 138(5), 2957-2963.

- Delgado, R.E., & Ozdamar, O. (2004). Deconvolution of evoked responses obtained at high stimulus rates. *Journal of the Acoustical Society of America*, 115(3), 1242-1251. doi: 10.1121/1.1639327
- Dixon, S. (2015). *Fast stimulus rate electrocochleography and auditory brainstem response using continuous loop averaging deconvolution in normal individuals and Ménière's patients* (Doctoral thesis). Missouri State University, Springfield.
- Durrant, J.D., Wang, J., Ding, D.L., & Salvi, R.J. (1998). Are inner or outer hair cells the source of summing potentials recorded from the round window? *Journal of the Acoustical Society of America*, 104(1), 370-377.
- Eysholdt, U., & Schreiner, C. (1982). Maximum length sequences: A fast method for measuring brain-stem-evoked responses. *Audiology*, 21, 242-250.
- Ferraro, J.A. (2010). Electrocochleography: A review of recording approaches, clinical applications, and new findings in adults and children. *Journal of the American Academy of Audiology*, 21, 145-152. doi: 10.3766/jaaa.21.3.2
- Ferraro, J.A., Arenberg, I.K., & Hassanein, R.S. (1985). Electrocochleography and symptoms of inner ear dysfunction. *Archives of Otolaryngology*, 111, 71-74.
- Ferraro, J.A., Best, L.G., Arenberg, I.K. (1983). The use of electrocochleography in the diagnosis, assessment, and monitoring of endolymphatic hydrops. *Otolaryngologic Clinics of North America*, 16(1), 69-82.
- Ferraro, J.A., Blackwell, W.L., Mediavilla, S.J., & Thedinger, B.S. (1994a). Normal summing potential to tone bursts recorded from the tympanic membrane in humans. *Journal of the American Academy of Audiology*, 5(1), 17-23.
- Ferraro, J.A., & Durrant, J.D. (2006). Electrocochleography in the evaluation of patients with Ménière's disease/endolymphatic hydrops. *Journal of the American Academy of Audiology*, 17, 45-68.
- Ferraro, J.A. & Krishnan, G. (1997). Cochlear potentials in clinical audiology. *Audiology & Neuro-Otology*, 2, 241-256.
- Ferraro, J.A., & Tibbils, R.P. (1999). SP/AP area ratio in the diagnosis of Ménière's disease. *American Journal of Audiology*, 8, 1-8. doi: 10.1044/1059-0889(1999/001)
- Ferraro, J.A., Thedinger, B.S., Mediavilla, S.J., & Blackwell, W.L. (1994b). Human summing potential to tone bursts: Observation on tympanic membrane versus promontory recordings in the same patients. *Journal of the American Academy of Audiology*, 5, 24-29.

- Filipo, R. & Barbara, M. (1997). Natural history of Ménière's disease: Staging the patients or their symptoms? *Acta Oto-laryngologica Supplemental*, 526, 10-13.
- Gibbin, K.P., Mason, S.M., & Singh, C.B. (1981). Glycerol dehydration tests in Ménière's disorder using ET electrocochleography. *Clinical Otolaryngology*, 6(6), 395-400.
- Gibson, W.P.R. (1993). A comparison of clicks versus tone bursts in the diagnosis of endolymphatic hydrops. In D. Hohmann (Ed.), *ECocG, OAE, and Intraoperative Monitoring: Proceedings of the First International Conference, Wurzburg, Germany, September 20-24, 1992* (pp. 55-59). Amsterdam: Kugler Publications.
- Gibson, W.P.R. (2009). A comparison of two methods using transtympanic electrocochleography for the diagnosis of Ménière's disease: click summing potential/action potential ratio measurements and tone burst summing potential measurements. *Acta Oto-Laryngologica*, 129, 38-42. doi: 10.1080/00016480902729843
- Goodman, A. (1965). Reference levels for pure-tone audiometer. *ASHA*, 7, 262-263.
- Haapaniemi, J., Laurikainen, E., Johansson, R., & Karjalainen, S. (2000). Transtympanic versus tympanic membrane electrocochleography in examining cochleovestibular disorders. *Acta Oto-laryngologica Supplemental*, 543, 127-129.
- Hornibrook, J., Coates, M., Goh, A., Gourley, J., & Bird, P. (2012). Magnetic resonance imaging for Ménière's disease: correlation with tone burst electrocochleography. *The Journal of Laryngology & Otology*, 126, 136-141. doi: 10.1017/S0022215111003112
- Huppert, D., Strupp, M., & Brandt, T. (2010). Long-term course of Ménière's disease revisited. *Acta Oto-Laryngologica*, 130, 644-651. doi: 10.3109/00016480903382808
- Iseli, C., & Gibson, W. (2010). A comparison of three methods of using transtympanic electrocochleography for the diagnosis of Ménière's disease: Click summing potential measurements, tone burst summing potential measurements, and biasing of the summing potential using a low frequency tone. *Acta Oto-Laryngologica*, 130, 95-101. doi: 10.3109/00016480902858899
- Kaf, W.A., Lewis, K.M., Yavuz, E., Dixon, S.M., van Ess, M., Jamos, A.M., and Delgado, R.E. (2017). Fast click rate electrocochleography and auditory brainstem response in normal-hearing adults using Continuous Loop Averaging Deconvolution. *Ear & Hearing*.

- Khatoon, M., Nighute, S., Awari, A., & Ishaque, M. (2012). The influence of aging on auditory evoked potential in advanced age group. *International Journal of Biomedical Research*, 3(11), 422-426.
- Leung, S.M., Slaven, A., Thornton, A.R., Brickley, G.J. (1998). The use of high stimulus rate auditory brainstem responses in the estimation of hearing threshold. *Hearing Research*, 123, 201-205.
- Levine, S.C., Margolis, R.H., Fournier, E.M., & Winzenburg, S.M. (1992). Tympanic electrocochleography for evaluation of endolymphatic hydrops. *Laryngoscope*, 102, 614-622.
- Lichtenhan, J.T., Cooper, N.P., & Guinan, J.J. (2013). A new auditory threshold estimation technique for low frequencies: Proof of concept. *Ear & Hearing*, 34(1), 42-51. doi: 10.1097/AUD.0b013e31825f9bd3
- Lichtenhan, J.T., Hartsock, J.J., Gill, R.M., Guinan, J.J., & Salt, A.N. (2014). The Auditory Nerve Overlapped Waveform (ANOW) originates in the cochlear apex. *Journal of the Association for Research in Otolaryngology*, 15(3), 395-411.
- Lutman, M.E., & Davis, A.C. (1994). The distribution of hearing threshold levels in the general population aged 18-30 years. *Audiology*, 33(6), 327-350
- Margolis, R.H., Ricks, D., Fournier, E.M., & Levine, S.E. (1995). Tympanic electrocochleography for diagnosis of Ménière's disease. *Archives of Otolaryngology – Head and Neck Surgery*, 121, 44-55.
- Mori, N., Saeki, K., Matsunaga, T., & Asai, H. (1982). Comparison between AP and SP parameters in trans- and ET electrocochleography. *Audiology*, 21, 228-241.
- Mouney, D.F., Cullen, J.K., Gondra, M.I., & Berlin, C.I. (1976). Tone burst electrocochleography in humans. *Transactions. Section on Otolaryngology*, 82, 348-355.
- Murakami, S., Gyo, K., & Goode, R.L. (1997). Effect of Middle Ear Pressure Change on Middle Ear Mechanics, *Acta Oto-Laryngologica*, 117(3), 390-395.
- Ohashi, T., Nishino, H., Arai, Y., Hyodo, M., & Takatsu, M. (2009). Clinical significance of the summing potential-action potential ratio and the action potential latency difference for condensation and rarefaction clicks in Ménière's disease. *Annals of Otolaryngology, Rhinology, & Laryngology*, 118(4), 207-212.
- Orchik, D.J., Ge, N.N., & Shea, J.J. (1998). Action potential latency shift by rarefaction and condensation clicks in Ménière's disease. *Journal of the American Academy of Audiology*, 9, 121-126.

- Ozdamar, O. & Bohorquez, J. (2006). Signal-to-noise ratio and frequency analysis of continuous loop averaging deconvolution (CLAD) of overlapping evoked potentials. *Journal of the Acoustical Society of America*, *119*(1), 429-438. doi: 10.1121/1.2133682
- Patel, K.C., Shah, C.J., & Mehta, H.B. (2014). Effect of age on brainstem auditory evoked potential. *International Journal of Science and Research*, *3*(12), 2551-2555.
- Sajjadi, H., & Paparella, M.M. (2008). Ménière's disease. *The Lancet*, *372*, 406-414.
- Salt, A.N., & Plontke, S.K. (2010). Endolymphatic hydrops: Pathophysiology and experimental models. *Otolaryngologic Clinic of North America*, *43*(5); 971-983. doi: 10.1016/j.otc.2010.05.007
- Sass, K. (1998). Sensitivity and specificity of transtympanic electrocochleography in Ménière's disease. *Acta Oto-Laryngologica*, *118*, 150-156.
- Schoonhoven, R., Fabius, M.A.W., & Grote, J.J. (1995). Input/output curves to tone bursts and clicks in ET and transtympanic electrocochleography. *Ear & Hearing*, *16*(6), 619-630.
- Smith, B.S., Lichtenhan, J.T., & Cone, B. (2016). Behavioral pure tone threshold shifts caused by tympanic membrane electrodes. *Ear & Hearing*, *37*(4), 273-275.
- Stypulkowski, P.H., & Staller, S.J. (1987). Clinical evaluation of new ECoG recording electrode. *Ear & Hearing*, *8*(5), 304-310.
- Valiente, A.R., Fidalgo, A.R., Berrocal, J.R.G., & Camacho, R.R. (2015). Hearing threshold levels for an ontologically screened population in Spain. *International Journal of Audiology*, *54*(8), 1-8.
- Wilson, W.J., & Bowker, C.A. (2002). The effects of high stimulus rate on the electrocochleogram in normal-hearing subjects. *International Journal of Audiology*, *41*, 509-517.
- Wuyts, F.L., Van de Heyning, P.H., Van Spaendonck, M.P., & Molenberghs, G. (1997). A review of electrocochleography: Instrumentation settings and meta-analysis of criteria for diagnosis of endolymphatic hydrops. *Acta Oto-Laryngologica Supplemental*, *526*, 14-20.
- Wuyts, F.L., Van de Heyning, P.H., Van Spaendonck, M., Van der Stappen, A., D'Haese, P., Erre, J.-P., ... Aran, J.-M. (2001). Rate influences on tone burst summing potential amplitude in electrocochleography: Clinical and experimental data. *Hearing Research*, *152*, 1-9.