



## Empirical Articles

# The Relevance of the SESII-W/M in Establishing a Relationship between Sexual Difficulties and Sexual Excitation/Inhibition

A Relevância da SESII-W / M no estabelecimento de uma relação entre dificuldades sexuais e excitação / inibição sexual

Victoria Paul\*<sup>a</sup>, Ana Carvalheira<sup>b</sup>

[a] ISPA - Instituto Universitário de Ciências Psicológicas, Sociais e da Vida, Lisboa, Portugal. [b] ISPA – William James Center for Research, Instituto Universitário de Ciências Psicológicas, Sociais e da Vida, Lisboa, Portugal.

## Abstract

**Aims:** The main purpose of this study is to analyse the relationship between sexual difficulties and factors of sexual arousal, excitement, and sexual inhibition among men and women.

**Method:** A total of 1,878 participants, of whom 983 were men (52%) and 895 were women (48%), with a mean age of 35.9 years (SD = 11.9; range = 18-79), were recruited online. The study's instruments included a socio-demographic questionnaire, a questionnaire about sexual difficulties, and the Sexual Excitation/Sexual Inhibition Inventory for Women and Men (SESII-W/M).

**Results:** Women with and without sexual difficulties differed significantly on all subscales of the SESII-W/M. Men with sexual difficulties scored significantly higher in the dimensions of Inhibitory Cognitions and the Dyadic Elements of the Sexual Interaction than men without difficulties. Inhibitory Cognitions was the strongest predictor of sexual difficulties for both men and women. Relationship Importance was also a strong predictor of sexual difficulties in women.

**Conclusions:** Sexual inhibition serves as a predictor of sexual difficulties. The SESII-W/M seems to work better in determining the factors of sexual inhibition as predictors of sexual difficulties among women, than in identifying causes of sexual difficulties among men.

**Keywords:** sexual difficulties, sexual arousal, sexual excitation, sexual inhibition

## Resumo

**Objetivos:** O propósito deste estudo foi o de analisar a relação entre as dificuldades sexuais e os fatores de excitação sexual, excitação e inibição sexual em homens e mulheres.

**Método:** Foram recrutados online 1878 participantes, entre os quais 983 homens (52%) e 895 mulheres (48%), com idades médias de 35.9 anos (*Mín* = 18, *Máx* = 79; *DP* = 11.9). Os instrumentos do estudo incluíram um questionário sociodemográfico, um questionário sobre dificuldades sexuais e o Inventário de Excitação Sexual /Inibição Sexual para Mulheres e Homens (the Sexual Excitation/Sexual Inhibition Inventory for Women and Men - SESII-W/M).

**Resultados:** Mulheres com e sem dificuldades sexuais diferem significativamente em todas as subescalas do SESII-W/M. Homens com dificuldades sexuais apresentaram valores significativamente mais elevados nas dimensões de Inibições Cognitivas e nos Elementos Diádicos da Interação Sexual, comparativamente aos homens sem dificuldades sexuais. As Cognições Inibitórias foram o preditor mais forte das dificuldades sexuais em mulheres.

**Conclusões:** A inibição sexual poderá servir como um preditor das dificuldades sexuais. O SESII-W/M parece funcionar melhor na determinação dos fatores da inibição sexual como preditores das dificuldades nas mulheres, do que na identificação das causas das dificuldades sexuais entre nos homens.

**Palavras-Chave:** dificuldades sexuais, excitação sexual, excitação sexual e inibição sexual

Psychology, Community & Health, 2019, Vol. 8(1), 27–44, <https://doi.org/10.5964/pch.v8i1.255>

Received: 2017-09-17. Accepted: 2018-11-25. Published (VoR): 2019-06-11.

Handling Editor: Cristina Godinho, Instituto Universitário de Lisboa (ISCTE-IUL), CIS-IUL, Lisbon, Portugal

\*Corresponding author at: Rua António Francisco, N° 43 - 1° Frente, Caparide, 2785-046 São Domingos de Rana, Portugal. E-mail: victoria.psicologia@outlook.com



This is an open access article distributed under the terms of the Creative Commons Attribution 4.0 International License, CC BY 4.0 (<https://creativecommons.org/licenses/by/4.0/>), which permits unrestricted use, distribution, and reproduction in any medium, provided the original work is properly cited.

Sexual dysfunction is described as a clinically significant disorder which prevents a person from responding to sexual stimuli or experiencing sexual pleasure (American Psychiatric Association, 2013). According to the fifth edition of the Diagnostic and Statistical Manual of Mental Disorders (DSM-5; American Psychiatric Association, 2013) sexual dysfunctions in men include delayed and premature ejaculation, erectile disorder and hypoactive sexual desire. Sexual dysfunctions in women include genito-pelvic pain/penetration disorder, sexual interest/arousal disorder, and orgasmic disorder. According to the DSM-5, substance/medication-induced sexual dysfunction, other specified sexual dysfunction, and unspecified sexual dysfunction can occur in both genders. Other specified sexual dysfunctions are defined as sexual dysfunctions that present symptoms, but do not meet the criteria for any of the previously mentioned disorders, and where the diagnosing clinician states a specific reason for this lack of classification. Unspecified sexual dysfunctions show symptoms of sexual dysfunction, but they do not meet the criteria for any of the previously mentioned disorders, and, in addition, the diagnosing clinician omits the reason for this lack of classification as there is insufficient information for a more thorough diagnosis. Factors such as stress, anxiety, sexual satisfaction, mood, and traits may also increase the tendency for inhibition, serving as triggers for sexual difficulties (Lykins, Janssen, Newhouse, Heiman, & Rafaeli, 2012). Hamilton and Julian (2014) sought to associate daily hassles (such as personal, financial and job stressors) with sexual functioning in 155 women and 91 men and found that women's negative sexual functioning was more strongly associated to stress and depression than that of men. Therefore, sexual difficulties are quite common and not necessarily dysfunctional in the clinical sense, as sexual functioning could be impaired due to external stressors (Bancroft, Loftus, & Long, 2003). A clinical diagnosis should be reserved for situations where sexual problems prove to be persistent and recurring (American Psychiatric Association, 2013). Furthermore, personal distress is a central criterion for the classification of sexual dysfunctions (American Psychiatric Association, 2013; Gomes & Nobre, 2014; Hatzimouratidis & Hatzichristou, 2007).

In 1999, Bancroft presented the Dual Control Model, proposing the existence of both excitatory and inhibitory mechanisms within the central nervous system that account for sexual responses, enabling an individual to react appropriately to sexual stimuli. As such, sexual arousal was considered as the result of excitatory and inhibitory tendencies. In order to become sexually aroused, levels of excitation rise, while levels of inhibition decrease. In addition, sexual inhibition increases, as an adaptive response in the face of a threat, providing potential protection against sexual risk-taking. However, a high level of inhibition outside of a threatening situation could be indicative of sexual dysfunction, whereas levels of inhibition that are too low could lead an individual to engage in high-risk sexual behaviour (Bancroft, 1999; Bancroft & Janssen, 2000; Janssen, Vorst, Finn, & Bancroft, 2002a, 2002b).

Building on the previous measures based on the Dual Control Model, such as the Sexual Inhibition/Sexual Excitation Scales (SIS/SES; cf. Janssen et al., 2002a, 2002b) and the Sexual Excitation/Sexual Inhibition Inventory for Women (SESII-W; cf. Graham, Sanders, & Milhausen, 2006), Milhausen, Graham, Sanders, Yarber, and Maitland (2010) came to the conclusion that measures to assess factors that inhibit and enhance sexual arousal in men and women were gender-specific, and endeavoured to create a scale that could be used by both genders, yielding comparable scores. Consequently, they developed the Sexual Excitation/Sexual Inhibition Inventory for Women and Men (SESII-W/M). However, this inventory produced significant gender differences and the authors point out the need for further investigation using a larger and more homogeneous sample, in order to better validate the use of the SESII-W/M for both genders.

In the past, research has been conducted to measure the propensity of sexual arousal in men and women, individuals, and couples (e.g. Bancroft & Janssen, 2000; Lykins et al., 2012). Furthermore, the SIS/SES has been applied in order to predict sexual dysfunctions in men, with and without a clinical diagnosis, indicating that erectile dysfunction can result from impaired arousability, as well as from a tendency to be sexually inhibited (Bancroft et al., 2005). Likewise, the SESII-W has been used to predict current and lifelong sexual problems in a sample of 540 heterosexual women (Sanders, Graham, & Milhausen, 2008), revealing the main predictors of sexual dysfunction to be the inhibitory factors of Arousal Contingency and Concerns about Sexual Functioning. Results of this study also suggest that sexual inhibition could help to better identify sexual difficulties in women, even more so than in men. Within the Portuguese population, several researchers have aimed to present estimates of the prevalence of sexual dysfunctions (Nobre, Pinto-Gouveia, & Gomes, 2006; Vendeira, Monteiro, Serrano, & Carvalheira, 2011; Vendeira, Pereira, Tomada, & de Carvalho, 2011) and, although these data offer an important contribution to the field of research, investigation is still directed towards the study of a specific gender. Several countries have evaluated the psychometric properties of the SESII-W (cf. Bloemendaal & Laan, 2015; Granados, Salinas, & Sierra, 2017; Velten, Scholten, Graham, & Margraf, 2016) but no studies can be found which apply a gender invariant measure. The present study focuses on sexual difficulties and their connection with sexual arousal and sexual inhibition in both men and women, thus filling this gap in the existing literature.

In the present study we did not assess the diverse DSM-5 criteria, such as personal distress, for example. Thus, for the purpose of this study, "sexual difficulties" are defined as experiencing one or more of the following sexual dysfunctions for the majority of the time during the last six months. For men, sexual difficulties included delayed ejaculation, premature ejaculation, difficulty in achieving or maintaining an erection, and a lack of sexual interest. For women, the identified sexual difficulties were a lack of sexual interest, difficulty experiencing an orgasm, and pain during sexual intercourse. We have maintained the terms "sexual difficulties" or "sexual problems" whenever these are originally used by the authors in the studies herein reported.

The dual control model is originally derived from the study of sexual dysfunction in men. The subsequently developed version of the SESII-W/M would serve as a predictor of sexual dysfunctions in men and women. Therefore, the main purpose of this study is to analyse the relationship between sexual difficulties and factors of sexual arousal/sexual inhibition among men and women, through the SESII-W/M.

## Method

### Procedure

Between March and April 2014, a link to an online survey on SurveyMonkey was posted on a popular Portuguese news website (Visão Online), in addition to being posted on another Internet portal related to the promotion of health and well-being (MSN Saúde). Upon clicking the link, participants viewed an informed consent statement, which described the aims of the study, guaranteed anonymity and confidentiality, and confirmed that the participants had read the statement and that they were over 18 years of age. No incentives or payments were offered for participation in this study. A total of 3,378 individuals followed the e-mail link to the web survey and completed the questionnaire.

Table 1

*Age, Number of Children, Educational Level and Relationship Status*

Sample characteristic (N = 1,878)	<i>M</i>	<i>SD</i>	<i>n</i>	%
<i>Age</i>				
Men	40	12.46		
Women	32	9.94		
<i>Number of Children</i>				
Men	2	0.84		
Women	2	0.69		
<i>Educational Level</i>				
Until 9th Grade			128	6.8
Until 12th Grade			539	28.7
Bachelor's degree			876	46.6
Master's degree			284	15.1
Doctoral degree			46	2.4
<i>Relationship Status</i>				
Committed without cohabitation			541	28.8
Committed with cohabitation (or married)			1,071	57.0
Not committed with no sexual partners			72	3.8
Not committed but with sexual partners			194	10.3
<i>Relationship Status</i>				
Committed without cohabitation			541	28.8
Committed with cohabitation (or married)			1,071	57.0
Not committed with no sexual partners			72	3.8
Not committed but with sexual partners			194	10.3

This study received ethical approval from the Instituto Universitário: Ciências Psicológicas, Sociais e da Vida's Ethics Committee.

## Participants

The study's authors determined the exclusion criteria for the 3,378 individuals who responded to the online questionnaire. One respondent indicated that he was under 18 years of age; thus, was immediately excluded from the study. Those who were not sexually active during the last 12 months ( $n = 357$ ) and those who did not indicate their gender ( $n = 980$ ) were also excluded from the analysis. From the remaining 2,040 individuals, only those whose sexual activity had been exclusively with the opposite sex (92%) were considered for this study.

Our final sample consisted of 1,878 Portuguese participants, of whom 983 were men (52.3%) and 895 were women (47.7%), with a mean age of 35.9 years ( $SD = 11.9$ ; range = 18-79). Respondents included residents from all Portuguese districts, but principally from the main metropolitan areas.

Approximately, two-thirds of participants (64.5%) reported having a university degree. Most (85.8%) of the sample members indicated that they were in a committed relationship (see Table 1), reporting a mean relationship duration of 11.1 years ( $SD = 10.72$ ). Close to half of the participants in relationships had children (49.8%), with 40.9% reporting that they had one child and 46.1% indicating that they had two.

## Measures

### Socio-Demographics

This questionnaire was designed by the authors to include questions concerning age, residential area by district, educational level, relationship status, relationship length, and number of children.

### Sexual Orientation

Sexual orientation was assessed using a behavioural measure inquiring whether a person's sexual activity during the last five years had been with a partner: 1 = "Exclusively of the opposite gender"; 2 = "Mainly of the opposite gender"; 3 = "Equally of the opposite gender and of the same gender"; 4 = "Mainly of the same gender"; 5 = "Exclusively of the same gender"; or 6 = "No sexual partners".

### Sexual Activity

A dichotomous question determined whether a person had been sexually active during the last 12 months, inquiring about any type of sexual intercourse with a partner.

### Sexual Difficulties

The authors designed questions aimed at determining the sexual difficulties experienced by men and women during the last six months. The items assessed four identified sexual difficulties in men, which included delayed ejaculation, premature ejaculation, difficulty in achieving or maintaining an erection, and a lack of sexual interest. The three sexual difficulties identified among women were a lack of sexual interest, difficulty experiencing an orgasm, and pain during sexual intercourse. A final question inquired about "Other sexual difficulties" and referred to sexual difficulties that were not included in any of the previous categories (e.g. anxiety related to sexual performance or self-image or any other kind of sexual inhibition). This question was deemed appropriate for both men and women. Answers were scored on a 4-point frequency assessment scale, in which the possible responses were: 1 = "Never"; 2 = "Occasionally"; 3 = "Half of the time"; and 4 = "Most of the time". Individuals who answered "Never" or "Occasionally" were considered by the authors as presenting no sexual difficulties. Participants who answered "Half of the time" presented mild and transitory sexual difficulties. Finally, sample members who answered "Most of the time" were regarded as reporting symptoms during the majority of their sexual activity and, therefore, were classified as experiencing sexual difficulties. As the study sought to identify men and women with and without sexual difficulties, two groups were created. Participants who responded "Most of the time" were included in the sexual difficulties group, while those responding "Never" and "Occasionally" were included in the group presenting no sexual difficulties. Sample members who responded "Half of the time" were not included in either group. It is also important to note that the answers regarding sexual difficulties were self-reported, and that respondents were not asked to identify if they had a clinical diagnosis.

### The Sexual Excitation/Sexual Inhibition Inventory for Women and Men (SESII-W/M)

This questionnaire measures an individual's propensity for sexual arousal when presented with certain stimuli, or if placed in a specific sexual situation (Milhausen et al., 2010). The inventory consists of six subscales with a total of 30 items. Three subscales refer to sexual excitation (SE) and three to sexual inhibition (SI). The first sexual inhibition subscale is Inhibitory Cognitions, which consists of eight items referring to cognitions or emotions that serve as inhibitors of sexual arousal. The second SI subscale is Relationship Importance, composed of five items that define the need to experience security and quality in a relationship, as well as other sexual inhibitors, such as the feelings of being used or emotionally hurt. The final SI subscale is the Dyadic Elements

of the Sexual Interaction, whose three items apply to inhibitors of sexual arousal, such as a lack of sensitivity regarding one's sexual signals on behalf of one's partner. Concerning the sexual excitation subscales, the first subscale, Arousability is composed of five items that indicate facilitators of arousal when presented with certain sexual stimuli. The second SE subscale is Partner Characteristics and Behaviours, which exams five items regarding certain causes of arousal, such as a partner's personality and characteristics (e.g., intelligence or talent) and the tasks performed by a partner (e.g., doing chores). The final SE subscale is known as Setting (Unusual or Unconcealed), which possesses four items regarding the intensity of arousal based on the sexual setting, for instance, the risk of being caught, or knowing that someone is nearby. Responses are given on a 4-point Likert scale ranging from 1 (strongly disagree) to 4 (strongly agree). Scores are obtained by calculating the mean for each factor, with higher scores indicating a stronger propensity for sexual inhibition or sexual arousal in each respective domain (Milhausen et al., 2010). The Portuguese version of this inventory (Neves, Milhausen, & Carvalheira, 2016) obtained Cronbach's alphas of .80 for Inhibitory Cognitions, .72 for Relationship Importance, .68 for Arousability, .65 for Partnership Characteristics and Behaviours, .53 for Setting (Unusual and Unconcealed), and .52 for the Dyadic Elements of the Sexual Interaction. Confirmatory factor analysis demonstrated an acceptable fit, yielding the following results:  $\chi^2/df = 6.69$  (poor); CFI = .81 (poor); PCFI = .72 (good); GFI = .90 (good); PGFI = .75 (poor); RMSEA = .06 (good) (Neves et al., 2016).

We applied a normality test to our sample and all factors fell within the normal range for skewness and kurtosis. Reliability of the SESII-W/M presented results of  $\alpha = .80$  for Inhibitory Cognitions,  $\alpha = .71$  for Relationship Importance,  $\alpha = .65$  for Arousability,  $\alpha = .65$  for Partnership Characteristics and Behaviours,  $\alpha = .51$  for Setting (Unusual or Unconcealed), and  $\alpha = .51$  for the Dyadic Elements of the Sexual Interaction.

## Data Analysis

We conducted a descriptive analysis of the data (absolute frequency, relative frequency, mean, and standard deviation), in addition to performing inferential statistics tests. A value of  $\alpha < 0.05$  (two-sided) was considered as the reference for accepting or rejecting the significance level of the null hypothesis. A Confirmatory Factor Analysis (CFA) was conducted for the SESII-W/M in order to determine whether the factor structure was in accordance with the original model. Student's *t*-tests for independent samples were used to assess differences in the means of each dimension. In situations where the homogeneity of variance assumption was not fulfilled, a Student's *t*-test using Welch's correction was performed. Multivariate logistic regressions were carried out to investigate sexual inhibitions and sexual arousal as predictors of sexual difficulties using the Hosmer-Lemeshow goodness-of-fit. The authors carried out subsequent data analysis using the Statistical Package for the Social Sciences (SPSS; version 21.0).

## Results

### Confirmatory Factor Analysis of The Sexual Excitation/Sexual Inhibition Inventory for Women and Men

In order to confirm the model presented by Milhausen et al. (2010) for the SESII-W/M, a CFA of the six factors, defined by the 30 items from this inventory, was designed (see Fig. 1). To be able to adjust the model, items 9 and 22 from the dimension "Relationship Importance", and items 4 and 25 from the dimension "Arousability",



had to be eliminated. The final model resulted in a weak, but acceptable, fit:  $\chi^2/df = 5,898$  (poor); CFI = .863 (poor); PCFI = .754 (good); GFI = .930 (good); PGFI = .752 (poor); RMSEA = .051 (good). Factor loadings ranged from -.34 to .71, with an average factor loading of .53. All factor loadings were significantly inter-correlated ( $p < .001$ ), except for Partner Characteristics and Behaviours and Dyadic Elements of the Sexual Relationship, Partner Characteristics and Behaviours and Relationship Importance, and Partner Characteristics and Behaviours and Inhibitory Cognitions.

## Sexual Difficulties Among Men and Women

The results regarding the frequency of self-reported sexual difficulties are presented in Table 2. The most frequently reported sexual difficulties were premature ejaculation for men (7.7%), and difficulty in experiencing an orgasm, for women (14.4%).

## Factors of Sexual Excitation/Sexual Inhibition by Gender

An independent-sample *t*-test was performed in order to compare the factors of sexual arousal and sexual inhibition for each gender. These results can be seen in Table 3.

Men obtained significantly higher scores in the dimensions of Arousability ( $M = 2.66$ ,  $SD = .42$ ) and Setting ( $M = 2.79$ ,  $SD = .40$ ), while women obtained significantly higher scores in the remaining dimensions.

## Factors of Sexual Excitation/Sexual Inhibition and Sexual Difficulties Among Men and Women

Independent-sample *t*-tests were conducted to compare men with and without sexual difficulties and women with and without sexual difficulties, in the context of the factors outlined by the SESII-W/M.

Men with sexual difficulties obtained significantly higher scores in the dimensions of Inhibitory Cognitions ( $M = 2.40$ ,  $SD = .42$ ), in comparison to those without sexual difficulties ( $M = 2.09$ ,  $SD = .42$ ). Men reporting sexual difficulties also scored higher ( $M = 2.73$ ,  $SD = .62$ ) than those not reporting sexual difficulties ( $M = 2.60$ ,  $SD = .50$ ) in regard to the dimension of the Dyadic Elements of the Sexual Interaction.

There were significant differences among all factors of the SESII-W/M between women with and without sexual difficulties. Women presenting sexual difficulties demonstrated significantly higher scores than women without sexual difficulties for the dimensions of Inhibitory Cognitions ( $M = 2.79$ ,  $SD = .41$  vs.  $M = 2.27$ ,  $SD = .43$ ), Relationship Importance ( $M = 3.03$ ,  $SD = .56$  vs.  $M = 2.92$ ,  $SD = .57$ ), and the Dyadic Elements of the Sexual Interaction ( $M = 2.99$ ,  $SD = .46$  vs.  $M = 2.80$ ,  $SD = .52$ ). Conversely, women not reporting sexual difficulties had significantly higher scores in the dimensions of Arousability ( $M = 2.43$ ,  $SD = .48$  vs.  $M = 2.15$ ,  $SD = .51$ ), Partner Characteristics and Behaviours ( $M = 2.45$ ,  $SD = .46$  vs.  $M = 2.29$ ,  $SD = .52$ ), and Setting (Unusual or Unconcealed) ( $M = 2.74$ ,  $SD = .43$  vs.  $M = 2.62$ ,  $SD = .45$ ), when compared with women who reported sexual difficulties.

A further *t*-test was performed to compare the factors of the SESII-W/M with each of the sexual difficulties for men (see Table 4).

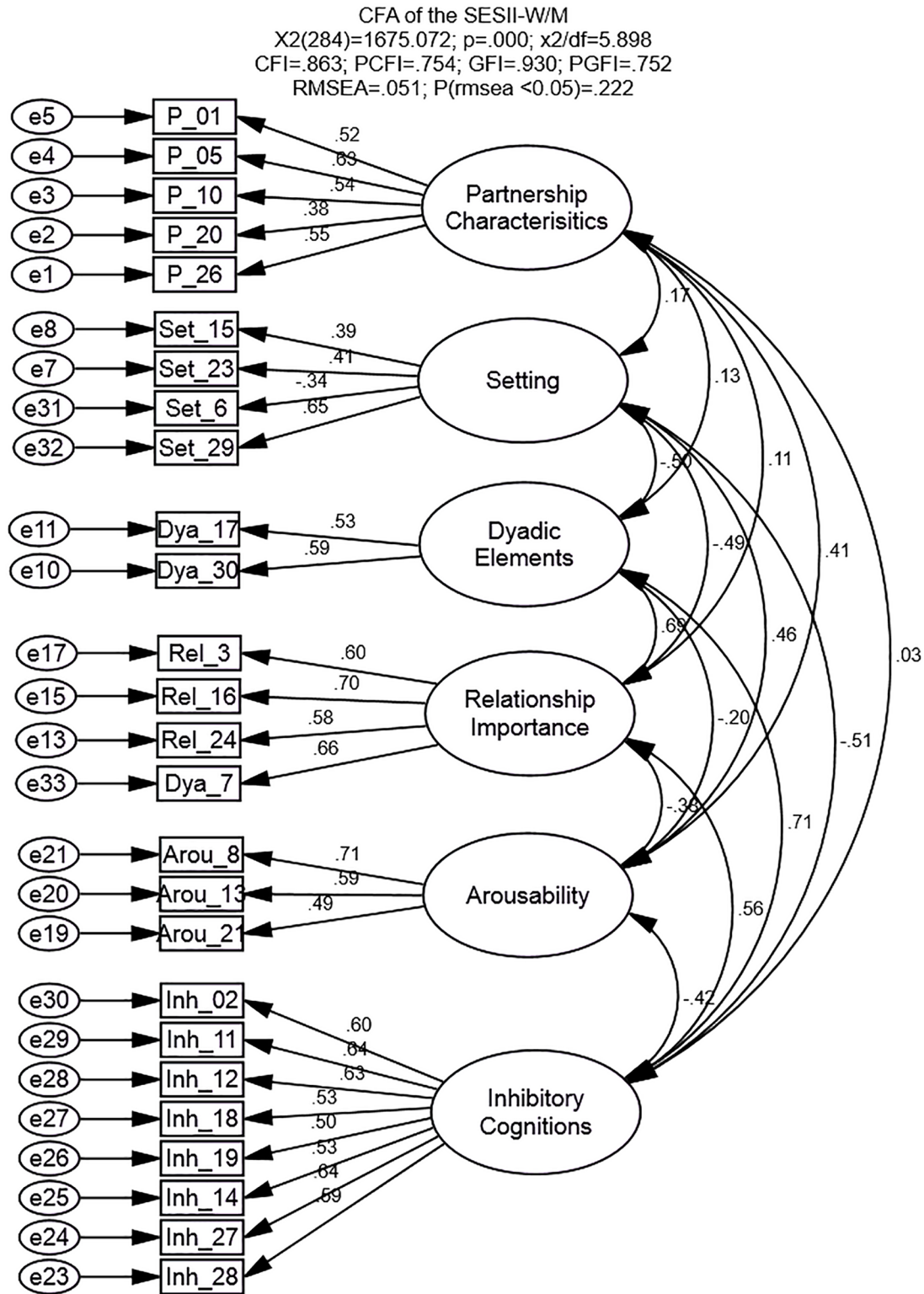

Figure 1. Results of confirmatory factor analysis of the SESII-W/M



Table 2

*Self-Reported Sexual Difficulties*

Sexual difficulty	Never		Occasionally		Half of the time		Most of the time	
	<i>n</i>	%	<i>n</i>	%	<i>n</i>	%	<i>n</i>	%
Men ( <i>n</i> = 983)								
Delayed ejaculation	370	37.6	499	50.8	68	6.9	46	4.7
Premature ejaculation	296	30.1	486	49.4	126	12.8	75	7.7
Difficulty in achieving or maintaining erection	485	49.3	429	43.6	54	5.5	15	1.6
Lack of sexual interest	545	55.4	391	39.8	33	3.4	14	1.4
Other sexual difficulties	656	66.7	300	30.5	21	2.1	6	0.7
Women ( <i>n</i> = 895)								
Lack of sexual interest	197	22.0	471	52.6	119	13.3	108	12.1
Difficulty experiencing orgasm	217	24.3	446	49.8	103	11.5	129	14.4
Pain during coitus	407	45.5	388	43.3	56	6.3	44	4.9
Other sexual difficulties	479	53.5	350	39.1	45	5.0	21	2.4

Table 3

*Comparison Between the SESII-W/M and Gender*

Subscale	Male		Female		<i>df</i>	<i>t</i>
	<i>M</i>	<i>SD</i>	<i>M</i>	<i>SD</i>		
Inhibitory Cognitions	2.19	0.47	2.46	0.48	1,876	-12.306***
Relationship Importance	2.51	0.51	2.97	0.56	1,876	-18.398***
Arousability	2.66	0.46	2.34	0.49	1,876	-18.307***
Partner Characteristics and Behaviours	2.34	0.45	2.40	0.48	1,876	14.631**
Setting (Unusual or Unconcealed)	2.79	0.40	2.71	0.44	1,876	-2.795***
Dyadic Elements of the Sexual Interaction	2.64	0.53	2.87	0.51	1,876	4.535***

\*\**p* < .01. \*\*\**p* < .001.

When observing the results for men with sexual difficulties, all of the sexual difficulties, with the exception of “premature ejaculation”, demonstrated significantly higher scores on the subscale of Inhibitory Cognitions. “Difficulty in achieving or maintaining an erection” and “other sexual difficulties” resulted in significantly higher scores for the Relationship Importance subscale. “Delayed ejaculation”, “difficulty in achieving or maintaining an erection”, and a “lack of sexual interest”, presented significantly higher scores for the Dyadic Elements of the Sexual Interaction dimension. Men without sexual difficulties indicated significantly higher scores for “difficulty in achieving or maintaining an erection” on the subscales of Arousability and Setting (Unusual or Unconcealed), and for a “lack of sexual interest” on the subscales of Partner Characteristics and Behaviours, as well as for Setting (Unusual or Unconcealed).

A *t*-test was once again conducted in order to compare the factors of the SESII-W/M with each of the sexual difficulties reported by women (see Table 5).

Results for a “lack of sexual interest” revealed that women with sexual difficulties showed significantly higher scores in all dimensions of sexual inhibition, whereas women without sexual difficulties demonstrated significantly higher scores in all dimensions of sexual arousal. The same applied to “pain during coitus”, which

Table 4

Comparison Between the SESII-W/M and Sexual Difficulties in Men

Subscale	M		t
	No	Yes	
Delayed ejaculation (n = 898)	n = 856	n = 42	
Inhibitory Cognitions (SI)	2.15	2.51	-4.843***
Relationship Importance (SI)	2.51	2.54	-0.279
Arousability (SE)	2.65	2.75	-1.060
Partner Characteristics and Behaviours (SE)	2.33	2.44	-1.447
Setting (Unusual or Unconcealed) (SE)	2.79	2.84	-0.674
Dyadic Elements of the Sexual Interaction (SI)	2.63	2.80	-2.110*
Premature ejaculation (n = 832)	n = 768	n = 64	
Inhibitory Cognitions (SI)	2.16	2.23	-1.086
Relationship Importance (SI)	2.50	2.53	-0.425
Arousability (SE)	2.66	2.70	-0.637
Partner Characteristics and Behaviours (SE)	2.34	2.30	0.757
Setting (Unusual or Unconcealed) (SE)	2.81	2.74	1.284
Dyadic Elements of the Sexual Interaction (SI)	2.63	2.61	0.139
Difficulty in achieving or maintaining erection (n = 914)	n = 899	n = 15	
Inhibitory Cognitions (SI)	2.14	3.18	-9.028***
Relationship Importance (SI)	2.49	3.11	-6.765***
Arousability (SE)	2.67	2.37	2.473*
Partner Characteristics and Behaviours (SE)	2.35	2.21	1.163
Setting (Unusual or Unconcealed) (SE)	2.80	2.50	2.910*
Dyadic Elements of the Sexual Interaction (SI)	2.62	3.09	-3.492***
Lack of sexual interest (n = 936)	n = 923	n = 13	
Inhibitory Cognitions (SI)	2.16	2.82	-5.082***
Relationship Importance (SI)	2.51	2.72	-1.228
Arousability (SE)	2.67	2.45	1.358
Partner Characteristics and Behaviours (SE)	2.34	2.11	2.609*
Setting (Unusual or Unconcealed) (SE)	2.80	2.54	2.325*
Dyadic Elements of the Sexual Interaction (SI)	2.64	2.97	-2.329*
Other sexual difficulties (n = 945)	n = 938	n = 7	
Inhibitory Cognitions (SI)	2.17	2.82	-3.715***
Relationship Importance (SI)	2.51	2.74	-3.222*
Arousability (SE)	2.67	2.54	0.916
Partner Characteristics and Behaviours (SE)	2.34	2.43	-0.979
Setting (Unusual or Unconcealed) (SE)	2.80	2.75	0.627
Dyadic Elements of the Sexual Interaction (SI)	2.64	2.81	-0.985

\*p < .05. \*\*\*p < .001.

showed significant differences between women with and women without sexual difficulties for all dimensions except for Partner Characteristics and Behaviours. In regard to, “Difficulty experiencing orgasm” and “other sexual difficulties”, women with sexual difficulties presented significantly higher scores for Inhibitory Cognitions and the Dyadic Elements of the Sexual Interaction. Women without sexual difficulties showed significantly higher scores for “other sexual difficulties” and for Partner Characteristics and Behaviours.

Table 5

Comparison Between the SESII-W/M and Sexual Difficulties in Women

Subscale	<i>M</i>		<i>t</i>
	No	Yes	
Lack of sexual interest ( <i>n</i> = 749)	<i>n</i> = 658	<i>n</i> = 91	
Inhibitory Cognitions (SI)	2.34	2.87	-10.722***
Relationship Importance (SI)	2.94	3.12	-2.920**
Arousability (SE)	2.44	1.94	9.314***
Partner Characteristics and Behaviours (SE)	2.45	2.21	4.475***
Setting (Unusual or Unconcealed) (SE)	2.75	2.52	4.653***
Dyadic Elements of the Sexual Interaction (SI)	2.83	3.06	-4.014***
Difficulty experiencing orgasm ( <i>n</i> = 759)	<i>n</i> = 650	<i>n</i> = 109	
Inhibitory Cognitions (SI)	2.36	2.82	-9.880***
Relationship Importance (SI)	2.95	2.97	-0.332
Arousability (SE)	2.37	2.28	1.805
Partner Characteristics and Behaviours (SE)	2.41	2.31	1.696
Setting (Unusual or Unconcealed) (SE)	2.71	2.66	1.037
Dyadic Elements of the Sexual Interaction (SI)	2.83	2.98	-2.698**
Pain during coitus ( <i>n</i> = 817)	<i>n</i> = 777	<i>n</i> = 40	
Inhibitory Cognitions (SI)	2.41	2.88	-6.217***
Relationship Importance (SI)	2.95	3.16	-2.210*
Arousability (SE)	2.36	2.12	3.040**
Partner Characteristics and Behaviours (SE)	2.40	2.27	1.782
Setting (Unusual or Unconcealed) (SE)	2.71	2.48	2.791***
Dyadic Elements of the Sexual Interaction (SI)	2.85	3.13	-3.374***
Other sexual difficulties ( <i>n</i> = 808)	<i>n</i> = 789	<i>n</i> = 19	
Inhibitory Cognitions (SI)	2.42	2.88	-4.228***
Relationship Importance (SI)	2.96	2.96	0.025
Arousability (SE)	2.35	2.16	1.704
Partner Characteristics and Behaviours (SE)	2.40	2.18	1.990*
Setting (Unusual or Unconcealed) (SE)	2.71	2.58	1.312
Dyadic Elements of the Sexual Interaction (SI)	2.86	3.14	-2.379*

\* $p < .05$ . \*\* $p < .01$ . \*\*\* $p < .001$ .

## Factors of Sexual Arousal and Sexual Inhibition as Predictors of Sexual Difficulties Among Men and Women

The authors of the study performed several multivariate logistic regressions designating each sexual difficulty as a dependent variable in the male sample (Table 6). Inhibitory Cognitions was the only significant predictor for all male sexual difficulties, except for premature ejaculation. Men who scored higher in Inhibitory Cognitions were more likely to report delayed ejaculation, erectile difficulties, a lack of sexual desire, and other sexual difficulties. Relationship Importance and the Dyadic Elements of the Sexual Interaction were significant predictors of erectile difficulties. The results of the Hosmer–Lemeshow test were not significant, thus pointing to an acceptable fit for all of the regression models, except for the regression concerning a lack of sexual desire.

The study's authors also carried out several multivariate logistic regressions using each sexual difficulty as a dependent variable in the female sample (Table 7). Inhibitory Cognitions was a significant predictor for all fe-

Table 6

*Inhibitory and Excitatory Factors as Predictors of Sexual Difficulties Among Men*

Subscale	Delayed ejaculation				Premature ejaculation				Difficulty in achieving or maintaining erection				Lack of sexual interest		Other sexual difficulties	
	OR		95% CI		OR		95% CI		OR		95% CI		OR		95% CI	
	OR	95% CI	OR	95% CI	OR	95% CI	OR	95% CI	OR	95% CI	OR	95% CI	OR	95% CI	OR	95% CI
Inhibitory Cognitions (SI)	4.33***	[2.18, 8.58]	1.35	[0.75, 2.42]	191.4***	[30.3, 1208.5]	12.0***	[3.82, 37.5]	19.4***	[4.37, 86.4]						
Relationship Importance (SI)	0.63	[0.31, 1.27]	1.22	[0.66, 2.27]	18.8**	[3.51, 101.4]	0.83	[0.23, 3.03]	0.96	[0.20, 4.54]						
Arousalability (SE)	1.71	[0.84, 3.49]	1.37	[0.75, 2.51]	0.72	[0.19, 2.70]	0.54	[0.15, 1.86]	0.91	[0.19, 4.30]						
Partner Characteristics (SE)	1.32	[0.67, 2.60]	0.73	[0.40, 1.32]	0.65	[0.17, 2.44]	0.39	[0.10, 1.44]	1.34	[0.26, 6.73]						
Setting (SE)	1.43	[0.65, 3.12]	0.76	[0.39, 1.45]	0.26	[0.05, 1.23]	0.33	[0.08, 1.32]	0.44	[0.07, 2.48]						
Dyadic Elements of the Sexual Interaction (SI)	1.13	[0.56, 2.28]	0.73	[0.40, 1.32]	0.13*	[0.02, 0.75]	1.76	[0.46, 6.70]	0.57	[0.10, 3.14]						
Cox and Snell $\Delta R^2$	.028		.004		.083		.043		.020							
Hosmer–Lemeshow statistic																
$\chi^2 (df = 8)$	18.34		18.45		2.35		33.60		4.34							
$p$	.019		.018		.968		.000		.825							

\* $p < .05$ . \*\* $p < .01$ . \*\*\* $p < .001$ .

Table 7

*Inhibitory and Excitatory Factors as Predictors of Sexual Difficulties Among Women*

Subscale	Lack of sexual interest		Difficulty experiencing orgasm		Pain during coitus		Other sexual difficulties	
	OR		95% CI		OR		95% CI	
	OR	95% CI	OR	95% CI	OR	95% CI	OR	95% CI
Inhibitory Cognitions (SI)	7.66***	[4.12, 14.24]	9.1***	[5.2, 15.9]	5.97***	[2.63, 13.56]	5.70**	[1.86, 17.42]
Relationship Importance (SI)	0.47**	[0.28, 0.81]	0.58*	[0.36, 0.92]	0.76	[0.37, 1.54]	0.23**	[0.08, 0.64]
Arousalability (SE)	0.14***	[0.07, 0.28]	1.23	[0.73, 2.06]	0.81	[0.37, 1.77]	0.74	[0.24, 2.83]
Partner Characteristics (SE)	0.92	[0.54, 1.55]	0.73	[0.45, 1.17]	0.91	[0.45, 1.86]	0.45	[0.16, 1.28]
Setting (SE)	0.58	[0.53, 1.01]	0.87	[0.53, 1.42]	0.43*	[0.20, 0.91]	0.62	[0.22, 1.74]
Dyadic Elements of the Sexual Interaction (SI)	1.29	[0.71, 2.35]	1.00	[0.60, 1.70]	1.47	[0.65, 3.35]	2.81	[0.88, 9.00]
Cox and Snell $\Delta R^2$	.14		.08		.05		.03	
Hosmer–Lemeshow statistic								
$\chi^2 (df = 8)$	10.94		8.68		2.84		9.75	
$p$	.20		.37		.94		.28	

\* $p < .05$ . \*\* $p < .01$ . \*\*\* $p < .001$ .

male sexual difficulties. Women who scored higher on Inhibitory Cognitions were also more likely to report a lack of sexual desire, a lack of the ability to orgasm, pain during sexual intercourse, and other sexual difficulties. Relationship Importance was a significant predictor for all female sexual difficulties, with the exception of pain during coitus. Women who scored higher in Relationship Importance were less likely to report a lack of sexual desire, a lack of being able to achieve orgasm, and other sexual difficulties. Women who scored higher on the Arousalability subscale were less likely to report a lack of sexual desire. Partnership Characteristics, Setting, and the Dyadic Elements of the Sexual Interaction were not significant predictors of any sexual difficulty. The results of the Hosmer–Lemeshow test were not significant, thus indicating that all regression models show an acceptable fit.

## Discussion

The purpose of this study was to analyse the relationship between sexual difficulties and the factors of sexual arousal/sexual inhibition among men and women.

Premature ejaculation was the highest reported sexual difficulty among the male population (7.7%), which is coherent with the results of a study carried out by [Gomes and Nobre \(2014\)](#) who examined 650 Portuguese men, 23% of whom reported rapid ejaculation as the most common sexual difficulty. The most reported sexual difficulty in women was difficulty in experiencing an orgasm (14.4%), closely followed by a lack of sexual interest (12.1%). Once again, this is in line with one of the largest studies on sexual dysfunctions carried out among 1,250 Portuguese women, which produced very comparable prevalence rates among various disorders (35% for sexual interest/arousal disorders, 34.1% for genito-pelvic pain and 31.6% for orgasmic disorders) ([Vendeira, Monteiro, et al., 2011](#)).

The comparison of the dimensions of the SESII-W/M with gender yielded the same results as those mentioned by [Milhausen et al. \(2010\)](#), revealing significantly higher scores for men in the dimensions of sexual arousal, namely Arousability and Setting. For women, significantly higher scores are evident in the dimensions of Inhibitory Cognitions, Relationship Importance, Partner Characteristics and Behaviours, and the Dyadic Elements of the Sexual Interaction. [Milhausen et al. \(2010\)](#) suggest that these differences in gender could also predict sexual attitudes and conduct. [Bancroft \(1999\)](#) suggests that the inhibitory process is more evolved in women than in men. The results of this study indicate that although men and women share similar qualities in regard to the production of sexual responses, gender differences are still quite apparent in a number of areas regarding sexuality.

Men with sexual difficulties scored higher on the dimensions of Inhibitory Cognitions and the Dyadic Elements of the Sexual Interaction, both of which are dimensions of sexual inhibition. "Difficulty in achieving or maintaining an erection" was the sexual difficulty most significantly related to all dimensions of the SESII-W/M, with the exception of the dimension of Partner Characteristics and Behaviours. Inhibitory Cognitions was the only significant predictor of all sexual difficulties in men, with the exception of premature ejaculation. In 2005, [Bancroft et al.](#) applied the SES/SIS to a clinical and to a non-clinical sample of men, in order to establish the relationship with erectile problems. Results between the two groups were similar. In both groups, scores for sexual inhibition were not related to premature ejaculation, confirming the findings of the present study. Sexual inhibition was higher in men demonstrating low sexual desire, in addition to among men indicating fear of rejection from their partners. Once again, this proves to be in line with the results of the present study, in which Relationship Importance and the Dyadic Elements of the Sexual Interaction proved to be significant predictors of erectile dysfunctions.

Women with sexual difficulties scored higher in the sexual inhibition dimensions. Additionally, women reporting a "lack of sexual interest" significantly differed from women not reporting this particular sexual difficulty on all factors of the SESII-W/M. Inhibitory Cognitions and Relationship Importance were significant predictors of all sexual difficulties.

Women who did not report sexual difficulties scored higher on all factors of sexual arousal, namely Arousability, Partner Characteristics and Behaviours, and Setting (Unusual or Unconcealed). The dimension of Inhibitory Cognitions was a significant predictor of all sexual difficulties in women. [Nobre and Pinto-Gouveia \(2008\)](#) car-

ried out a study to determine cognitive and emotional predictors of sexual dysfunctions in a sample of 207 women. They determined that women with sexual dysfunctions (regardless of the sexual dysfunction presented) more frequently possessed negative thoughts regarding sexual activity than women without sexual dysfunctions. In their study of the SESII-W as a predictor of sexual problems, [Sanders et al. \(2008\)](#), determined that the inhibition factors of Arousal Contingency and Concerns about Sexual Function were strong predictors of sexual problems, in addition to relating partnership and relationship factors to orgasm difficulties. The present study further expounds upon this idea, as it demonstrates a connection between Relationship Importance and all sexual difficulties, except pain during coitus. The reasons behind why women choose to engage in sexual intercourse are diverse and complex, yet they may often include the need to feel close to their partners. Initially, a woman may not feel sexually aroused, relying on sexual stimulation from both herself and her partner in order to enable her to enjoy the sexual experience ([Basson, 2005](#)). In a study with 3,687 Portuguese women, [Carvalho, Brotto, and Leal \(2010\)](#) determined that a woman might engage in sexual activity in order to please her partner, whether or not she initially feels sexual desire. However, in general, once a woman becomes sexually involved, she is easily aroused. Among a sample of 1,332 Spanish men and women, [Moyano and Sierra \(2014\)](#) found that respondents considered intimate thoughts (e.g. thoughts about having intercourse with a romantic partner) to be the most pleasant and that these thoughts most frequently produced assessed positive cognitions. These studies partially enlighten us about the importance of a woman's partner's role in her sexual arousal. They also reveal that negative thoughts regarding sexuality could serve as a trigger for sexual inhibition and that frequent negative cognitions could lead to sexual dysfunction. However, future investigation is needed in order to determine a causal relationship between these factors.

The dual control model infers that individuals with a high propensity for sexual inhibition, or with low levels of arousal, may present a greater vulnerability to sexual dysfunctions ([Bancroft, 1999](#); [Bancroft & Janssen, 2000](#); [Janssen et al., 2002a, 2002b](#)). This idea is corroborated by the present study, which indicates that factors of sexual inhibition, such as Inhibitory Cognitions and Relationship Importance, are strong predictors of sexual difficulties in both men and women. Another interesting finding is that both men and women who reported experiencing sexual difficulties "most of the time" scored higher on factors related to sexual inhibition. In contrast, those who fell into the group of no sexual difficulties ("Never" and "Occasionally") indicated significantly higher scores in dimensions associated with sexual arousal, reinforcing the connection between sexual difficulties and sexual inhibition. It is interesting to note that when comparing factors of SE and SI, men scored higher on two out of three subscales of SE, namely Arousability and Setting, whereas women scored higher on the subscale of Partnership Characteristics and Behaviour and on all subscales of SI which suggests that although the SESII-W/M can be applied to both men and women, this instrument represents significant gender differences.

Certain limitations of the study must also be addressed. The Portuguese version of the SESII-W/M ([Neves et al., 2016](#)) raises a few additional questions. The version resulted in a weak, although acceptable, model fit. Internal consistency for the dimensions of Setting (Unusual or Unconcealed) and the Dyadic Elements of the Sexual Interaction were poor ( $\alpha = .53$  and  $\alpha = .52$ , respectively). The results of both of these factors also demonstrated poor internal consistency in the present study. [Neves et al. \(2016\)](#) suggest that the low values of internal consistency in both the Dyadic Elements of the Sexual Interaction and Setting could be due to the reduced number of subscale items in each of these dimensions, as well as the fact that two of the items of the dimension of Setting are reverse coded. However, confirmatory factor analysis indicated a modest model fit, thus the authors suggest that the 6-factor, 30-item model be maintained. In the present study, confirmatory fac-



tor analysis presented a weak, although acceptable fit. Further studies are required in order to confirm these results.

Participants were recruited online using a web-based survey. Online recruitment and data collection present several advantages, for instance, participants are less likely to fear the consequences of social evaluation, allowing them to respond honestly, especially regarding delicate matters such as sexuality, while simultaneously maintaining their anonymity (Carvalheira, 2007; Cooper, Scherer, & Mathy, 2001; Mustanski, 2001). These methods are also time-saving and can reach a larger and more diversified population (Shaughnessy, Zechmeister, & Zechmeister, 2006). The Internet has become an important tool for accessing and collecting data when dealing with sensitive subjects such as sexuality (Pealer, Weiler, Pigg, Miller, & Dorman, 2001; Shaughnessy et al., 2006; Turner et al., 1998). On the other hand, online surveys also present some drawbacks. The Internet is not accessible to certain population subgroups, which, even if they do manage to obtain Internet access, may be technologically illiterate. Therefore, online surveys do not represent the general population as a whole. Moreover, the absence of an interviewer to clarify and verify respondents' uncertainties, could have lead to biased answers, representing a lack of control over the sample (Fricker, & Rand, 2002; Jansen, Corley, & Jansen, 2007; Phellas, Bloch, & Seale, 2011). The subjects who visited the websites used for sample recruitment and who agreed to the publication of the study, were highly educated overall, with 64.5% reporting having a university degree. Therefore, the sample used in this study should be considered as under-representative of the lower-class population.

Several different questionnaires have been developed to assess sexual arousal and sexual inhibition in women and men, including the Sexual Inhibition Scale (SIS), the Sexual Excitation Scale (SES) (SIS/SES; Janssen et al., 2002a, 2002b), the Sexual Excitation/Sexual Inhibition Inventory for Women (SESII-W; Graham et al., 2006), and the SESII-W/M (Milhausen et al., 2010). Past and current research has shown us that, while any of these instruments can be used to establish sexual inhibitions as predictors of sexual dysfunctions, the advantage of the SESII-W/M is that it may be applied to both men and women, although it does capture a difference between genders, indicating that in order for women to be sexually functional and devoid of problems, more conditions need to be met.

A correlational design enabled the establishment of associations between the factors of sexual inhibition, the factors of sexual arousal, and sexual difficulties, revealing an evident relationship between these factors, in addition to expanding upon findings from previous studies. However, although associations among variables are apparent, this does not necessarily signify causation. Therefore, the basis for each of these occurrences was not determined and, in order to establish a casual relationship, further investigation is required. Nonetheless, this study has proven to be innovative due to its combination of the variables under study and through its ability to demonstrate a relationship among them.

## Funding

The authors have no funding to report.

## Competing Interests

The authors have declared that no competing interests exist.

## Acknowledgments

The authors would like to thank Robin Milhausen for her kind suggestions for this paper.

## References

- American Psychiatric Association. (2013). *Diagnostic and statistical manual of mental disorders* (5th ed). Washington, DC, USA: American Psychiatric Publishing.
- Bancroft, J. (1999). Central inhibition of sexual response: A theoretical perspective. *Neuroscience and Biobehavioral Reviews*, 23(6), 763-784. [https://doi.org/10.1016/S0149-7634\(99\)00019-6](https://doi.org/10.1016/S0149-7634(99)00019-6)
- Bancroft, J., Hergenick, D., Barnes, T., Hallam-Jones, R., Wylie, K., . . . Turner, G. (2005). The relevance of the dual control model to male sexual dysfunction: The Kinsey Institute/BASRT collaborative project. *Sexual and Relationship Therapy*, 20(1), 13-30. <https://doi.org/10.1080/14681990512331298275>
- Bancroft, J., & Janssen, E. (2000). The dual control model of male sexual response: A theoretical approach to centrally mediated erectile dysfunction. *Neuroscience and Biobehavioral Reviews*, 24, 571-579. [https://doi.org/10.1016/S0149-7634\(00\)00024-5](https://doi.org/10.1016/S0149-7634(00)00024-5)
- Bancroft, J., Loftus, J., & Long, S. (2003). Distress about sex: A national survey of women in heterosexual relationships. *Archives of Sexual Behavior*, 32(3), 193-208. <https://doi.org/10.1023/A:1023420431760>
- Basson, R. (2005). Women's sexual dysfunction: Revised and expanded definitions. *Canadian Medical Association Journal*, 172(10), 1327-1333. <https://doi.org/10.1503/cmaj.1020174>
- Bloemendaal, L. B. A., & Laan, E. T. M. (2015). The psychometric properties of the Sexual Excitation/Sexual Inhibition Inventory for Women (SESII-W) within a Dutch population. *Journal of Sex Research*, 52(1), 69-82. <https://doi.org/10.1080/00224499.2013.826166>
- Carvalho, A. (2007). Novas metodologias de investigação psicológica na Internet: Uma revisão teórica. *Psychologica*, 46, 67-84.
- Carvalho, A., Brotto, L. A., & Leal, I. (2010). Women's motivations for sex: Exploring the Diagnostic and Statistical Manual, fourth edition, text revision criteria for Hypoactive Sexual Desire and Female Sexual Arousal Disorders. *Journal of Sexual Medicine*, 7, 1454-1463.
- Cooper, A., Scherer, C., & Mathy, R. M. (2001). Overcoming methodological concerns in the investigation of online sexual activities. *Cyberpsychology & Behavior*, 4(4), 437-447. <https://doi.org/10.1089/109493101750526999>
- Fricker, R. D., Jr, & Rand, M. S. (2002). Advantages and disadvantages of internet research surveys: Evidence from literature. *Field Methods*, 14(4), 347-367. <https://doi.org/10.1177/152582202237725>
- Gomes, A. L. Q., & Nobre, P. J. (2014). Prevalence of sexual problems in Portugal: Results of a population-based study using a stratified sample of men ages 18 to 70 years. *Journal of Sex Research*, 51(1), 13-21. <https://doi.org/10.1080/00224499.2012.744953>
- Graham, C. A., Sanders, S. A., & Milhausen, R. R. (2006). The Sexual Excitation/Sexual Inhibition Inventory for Women: Psychometric properties. *Archives of Sexual Behavior*, 35(4), 397-409. <https://doi.org/10.1007/s10508-006-9041-7>

- Granados, M. R., Salinas, J. M., & Sierra, J. C. (2017). Spanish version of the Sexual Excitation/Sexual Inhibition Inventory for Women: Factorial structure, reliability and validity evidences. *International Journal of Clinical and Health Psychology*, 17, 65-76. <https://doi.org/10.1016/j.ijchp.2016.09.003>
- Hamilton, L. D., & Julian, A. M. (2014). The relationship between daily hassles and sexual function in men and women. *Journal of Sex & Marital Therapy*, 40(5), 379-395. <https://doi.org/10.1080/0092623X.2013.864364>
- Hatzimouratidis, K., & Hatzichristou, D. (2007). Sexual dysfunctions: Classifications and definitions. *Journal of Sexual Medicine*, 4(1), 241-250. <https://doi.org/10.1111/j.1743-6109.2007.00409.x>
- Jansen, K. J., Corley, K. G., & Jansen, B. J. (2007). E-Survey methodology: In R. A. Reynolds, R. Woods, & J. D. Baker (Eds.). *Handbook of research on electronic measurements* (pp. 1-8). Hershey, PA, USA: Idea Group Reference.
- Janssen, E., Vorst, H., Finn, P., & Bancroft, J. (2002a). The Sexual Inhibition (SIS) and Sexual Excitation (SES) Scales: I. Measuring sexual inhibition and excitation proneness in men. *The Journal of Sexual Research*, 39(2), 114-126. <https://doi.org/10.1080/00224490209552>
- Janssen, E., Vorst, H., Finn, P., & Bancroft, J. (2002b). The Sexual Inhibition (SIS) and Sexual Excitation (SES) Scales: II. Predicting psychophysiological response patterns. *Journal of Sex Research*, 39(2), 127-132. <https://doi.org/10.1080/00224490209552131>
- Lykins, A. D., Janssen, E., Newhouse, S., Heiman, J. R., & Rafaeli, E. (2012). The effects of similarity in sexual excitation, inhibition, and mood on sexual arousal problems and sexual satisfaction in newlywed couples. *Journal of Sexual Medicine*, 9, 1360-1366. <https://doi.org/10.1111/j.1743-6109.2012.02698.x>
- Milhausen, R. R., Graham, C. A., Sanders, S. A., Yarber, W. L., & Maitland, S. B. (2010). Validation of the Sexual Excitation/Sexual Inhibition Inventory for Women and Men. *Archives of Sexual Behavior*, 39(5), 1091-1104. <https://doi.org/10.1007/s10508-009-9554-y>
- Moyano, N., & Sierra, J. C. (2014). Positive and negative sexual cognitions: Similarities and differences between men and women from southern Spain. *Sexual and Relationship Therapy*, 29(4), 454-466. <https://doi.org/10.1080/14681994.2014.934667>
- Mustanski, B. S. (2001). Getting wired: Exploiting the Internet for the collection of valid sexuality data. *Journal of Sex Research*, 38(4), 292-301. <https://doi.org/10.1080/00224490109552100>
- Neves, C. F., Milhausen, R. R., & Carvalheira, A. (2016). Sexual Excitation/Sexual Inhibition Inventory (SESII-W/M): Adaptation and validation within a Portuguese sample of men and women. *Journal of Sex & Marital Therapy*, 42(6), 552-565. <https://doi.org/10.1080/0092623X.2015.1113579>
- Nobre, P. J., & Pinto-Gouveia, J. (2008). Cognitive and emotional predictors of female sexual dysfunctions: Preliminary findings. *Journal of Sex & Marital Therapy*, 34, 325-342. <https://doi.org/10.1080/00926230802096358>
- Nobre, P. J., Pinto-Gouveia, J., & Gomes, F. A. (2006). Prevalence and comorbidity of sexual dysfunctions in a Portuguese clinical sample. *Journal of Sex & Marital Therapy*, 32, 173-182. <https://doi.org/10.1080/00926230500442334>
- Pealer, L. N., Weiler, R. M., Pigg, R. M., Miller, D., & Dorman, S. M. (2001). The feasibility of a web-based surveillance system to collect health risk behavior data from college students. *Health Education and Behavior*, 28(5), 547-559. <https://doi.org/10.1177/1090198101028>

- Phellas, C. N., Bloch, A., & Seale, C. (2011). Structured methods: Interviews, questionnaires and observation. In C. Seale (Ed.), *Researching society and culture* (pp. 181-205). London, England: Sage.
- Sanders, S. A., Graham, C. A., & Milhausen, R. R. (2008). Predicting sexual problems in women: The relevance of sexual excitation and sexual inhibition. *Archives of Sexual Behavior, 37*(2), 241-251. <https://doi.org/10.1007/s10508-007-9235-7>
- Shaughnessy, J. J., Zechmeister, E. B., & Zechmeister, J. S. (2006). *Research methods in psychology*. New York, NY, USA: McGraw-Hill.
- Turner, C. F., Ku, L., Rogers, S. M., Lindberg, L. D., Pleck, J. H., & Stonenstien, F. L. (1998). Adolescent sexual behavior, drug use, and violence: Increased reporting with computer survey technology. *Science, 280*, 867-873. [http://www.columbia.edu/itc/hs/pubhealth/p8473/misc/turner\\_lec\\_2.pdf](http://www.columbia.edu/itc/hs/pubhealth/p8473/misc/turner_lec_2.pdf)<https://doi.org/10.1126/science.280.5365.867>
- Velten, J., Scholten, S., Graham, C. A., & Margraf, J. (2016). Psychometric properties of the Sexual Excitation/Sexual Inhibition Inventory for Women in a German sample. *Archives of Sexual Behavior, 45*, 303-314. <https://doi.org/10.1007/s10508-015-0547-8>
- Vendeira, P., Monteiro, N., Serrano, F., & Carvalheira, A. (2011). Estudo EPISEX-PT/Feminino: Prevalência das disfunções sexuais femininas em Portugal. *Cadernos de Sexologia, 4*, 7-14.
- Vendeira, P., Pereira, N. M., Tomada, N., & de Carvalho, L. (2011). Estudo EPISEX-PT/Masculino: Prevalência das disfunções sexuais masculinas em Portugal. *Cadernos de Sexologia, 4*, 15-22.