

SUNY College of Environmental Science and Forestry

Digital Commons @ ESF

Living Snow Fence Presentations

Living Snow Fences

2012

NYS DOT Living Snow Fence Training Program 2012

Timothy A. Volk

SUNY College of Environmental Science and Forestry

Justin P. Heavey

SUNY College of Environmental Science and Forestry

Lawrence P. Abrahamson

SUNY College of Environmental Science and Forestry

Philip J. Castellano

SUNY College of Environmental Science and Forestry

Follow this and additional works at: <https://digitalcommons.esf.edu/lfspres>



Part of the [Agricultural Science Commons](#), and the [Agriculture Commons](#)

Recommended Citation

Volk, Timothy A.; Heavey, Justin P.; Abrahamson, Lawrence P.; and Castellano, Philip J., "NYS DOT Living Snow Fence Training Program 2012" (2012). *Living Snow Fence Presentations*. 2.

<https://digitalcommons.esf.edu/lfspres/2>

This Presentation is brought to you for free and open access by the Living Snow Fences at Digital Commons @ ESF. It has been accepted for inclusion in Living Snow Fence Presentations by an authorized administrator of Digital Commons @ ESF. For more information, please contact digitalcommons@esf.edu, cjkoons@esf.edu.

NYSDOT Living Willow Snow Fence Training Program 2012



T. A. Volk, L.P. Abrahamson, J. Heavey, and P.J. Castellano
State University of New York College of Environmental Science and Forestry
NYSDOT Snow Fence Training, Utica, NY, May 2012



First Class Session– Principles of Blowing Snow and Living Snow Fence Design

- ◆ Structural and living snow fences
- ◆ Principles of moving snow
- ◆ How snow fences work
- ◆ Snow fence design
- ◆ Site assessment for living snow fences



Today's Training

- ◆ Selecting plants for living snow fences
- ◆ Installation and maintenance of living snow fences
 - Site preparation
 - Weed control both chemical and mechanical
 - Planting living snow fences
 - Post planting weed control



Selecting Plants for Living Snow Fences

Plant Hardiness Zones

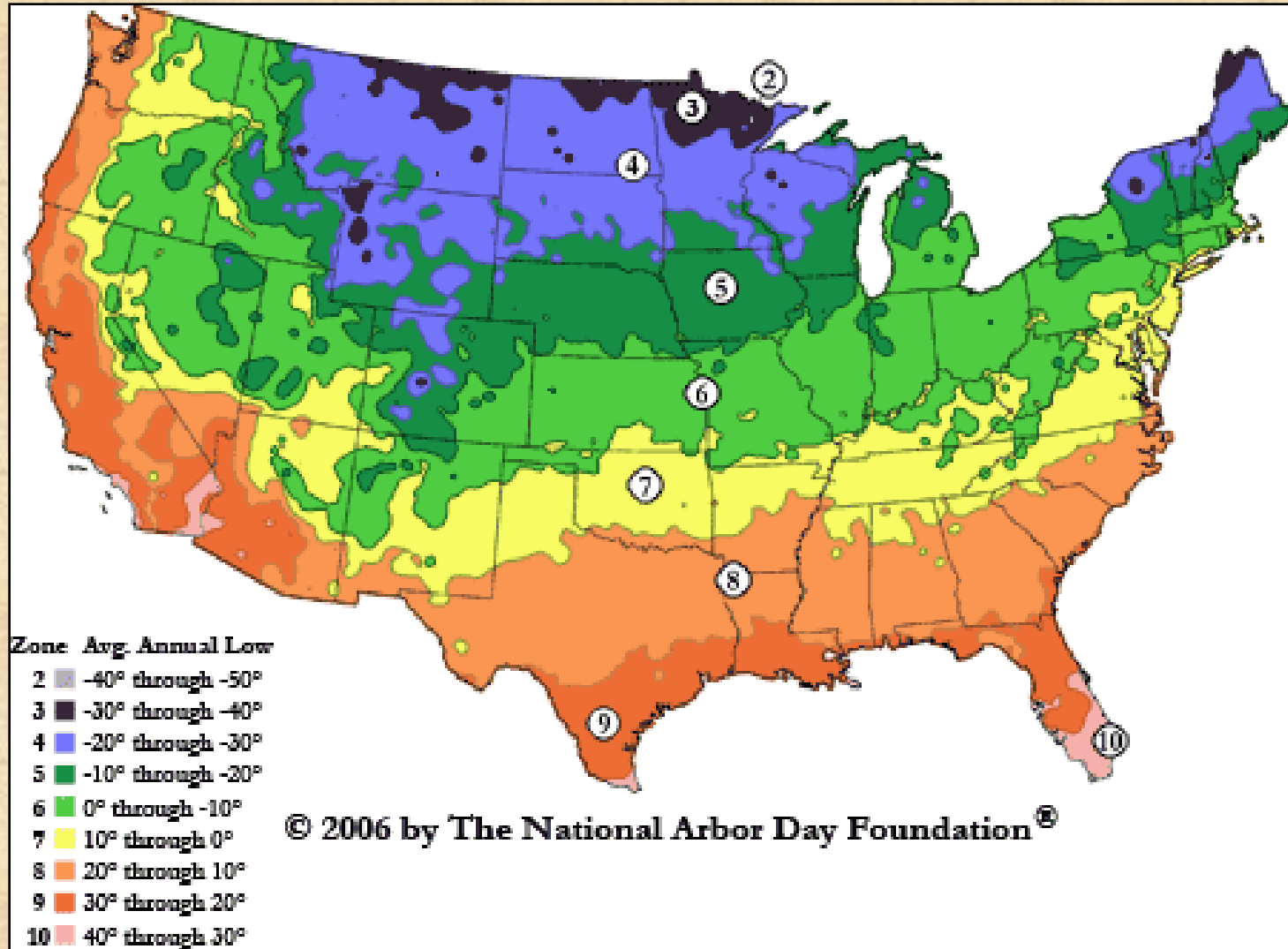



Selecting Plants – Growth Characteristics

- ◆ A limitation of living snow fences is the time required for them to become effective
 - Can take up to 20 years
 - But can be as short as 2 – 3 years
- ◆ Time for living snow fences to become effective depends on:
 - Site preparation prior to planting
 - Growth rate of plants
 - Growth form and habit of plants
 - Spacing of plants
 - Management of site (weeds and nutrients)
 - Quantity of snow transport



Selecting Plants – Growth Characteristics

◆ Growth rate

- Slower growing plants will take longer to form an effective living snow fence
 - » In some cases this can be 15 – 20 years
 - » Greater potential for damage during this time resulting in gaps
- Effect of living snow fence will vary as the plants develop, so different growth stages should be considered in the design
- Interim measures, such as structural snow fences may be required
- Care in placement is necessary so developing plants do not become buried and damaged by snow drifts
- Using a mixture of plants with slower and faster growth rates can be effective



First Year Growth of Shrub Willow Double Row Living Snow Fence



Willow Living Snow Fence

One Year Regrowth on Two Year Old Roots





Willow Living Snow Fence

Two Year Regrowth on Three Year Old Roots



Selecting Plants – Growth Characteristics



This variety of willow (*S. purpurea*) had prostrate growth when planted in a single row living snow fence

- ◆ Height of the plant where the density is great enough to influence wind speed
 - Effective height of the plant will influence the amount of snow that can be stored
 - Effective height does not necessarily correspond to the general height of the plant



Selecting Plants – Growth Characteristics

- ◆ Plants need to have dense foliage or branching pattern that extends to close to ground level
 - Self pruning species should be avoided
 - Large gaps ($> 10 - 15\%$ of snow fence height) at the bottom of the plant can create wind tunnels and exacerbate blowing snow problems



Selecting Plants – Growth Characteristics

- ◆ A larger space between the ground and the bottom of the snow fence minimizes snow deposition close to the snow fence
- ◆ With strong winds and a solid structural (Wyoming) snow fence, larger gaps creates a longer distribution pattern and less snow accumulation on the windward side
- ◆ Fences that become buried are less efficient at trapping snow

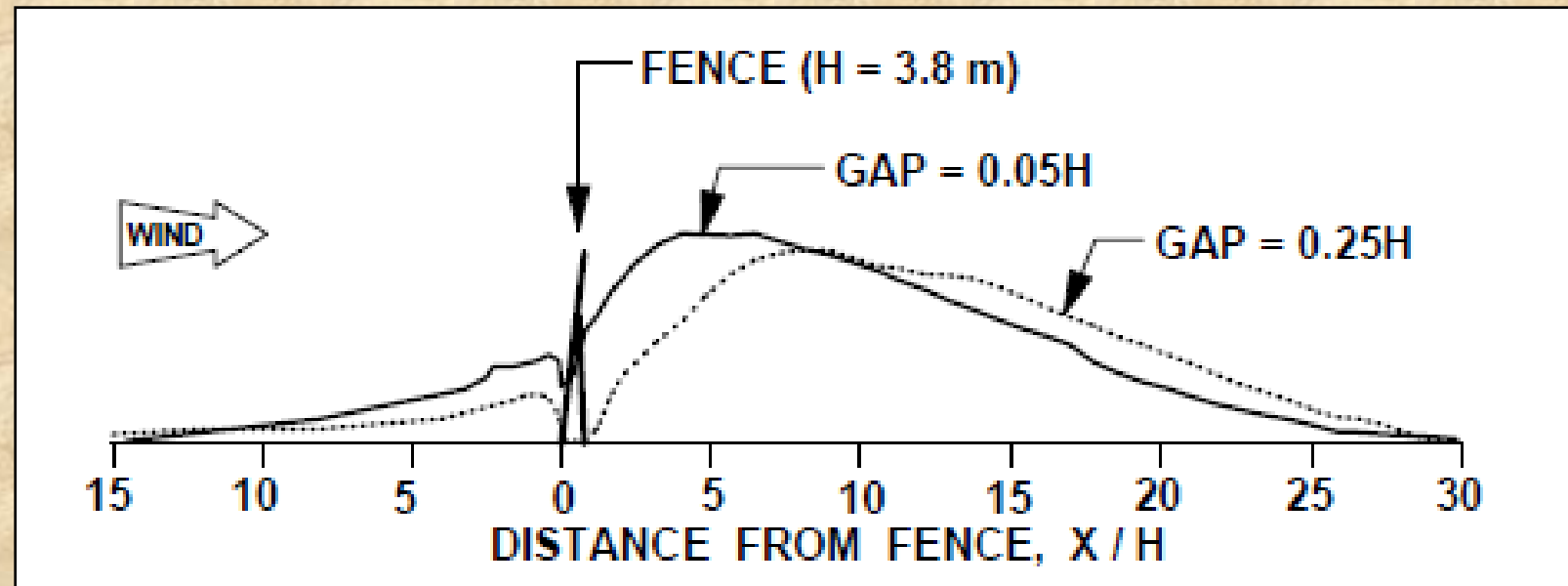



Selecting Plants – Growth Characteristics

- ◆ Gaps or openings in living snow fences caused by mortality can result in large drifts downwind
 - Avoid creation of gaps by planting multiple rows and staggering plantings
 - Select plants that are suited to the conditions of the site
 - Gaps that do result should be filled with structural snow fence until replacement vegetation can be established

Continuous Living Snow Fences

- ◆ Snow fences should be continuous without openings
- ◆ Access fields and rights-of-way around ends of snow fences
- ◆ If access lanes are required, place them at an angle to the prevailing wind

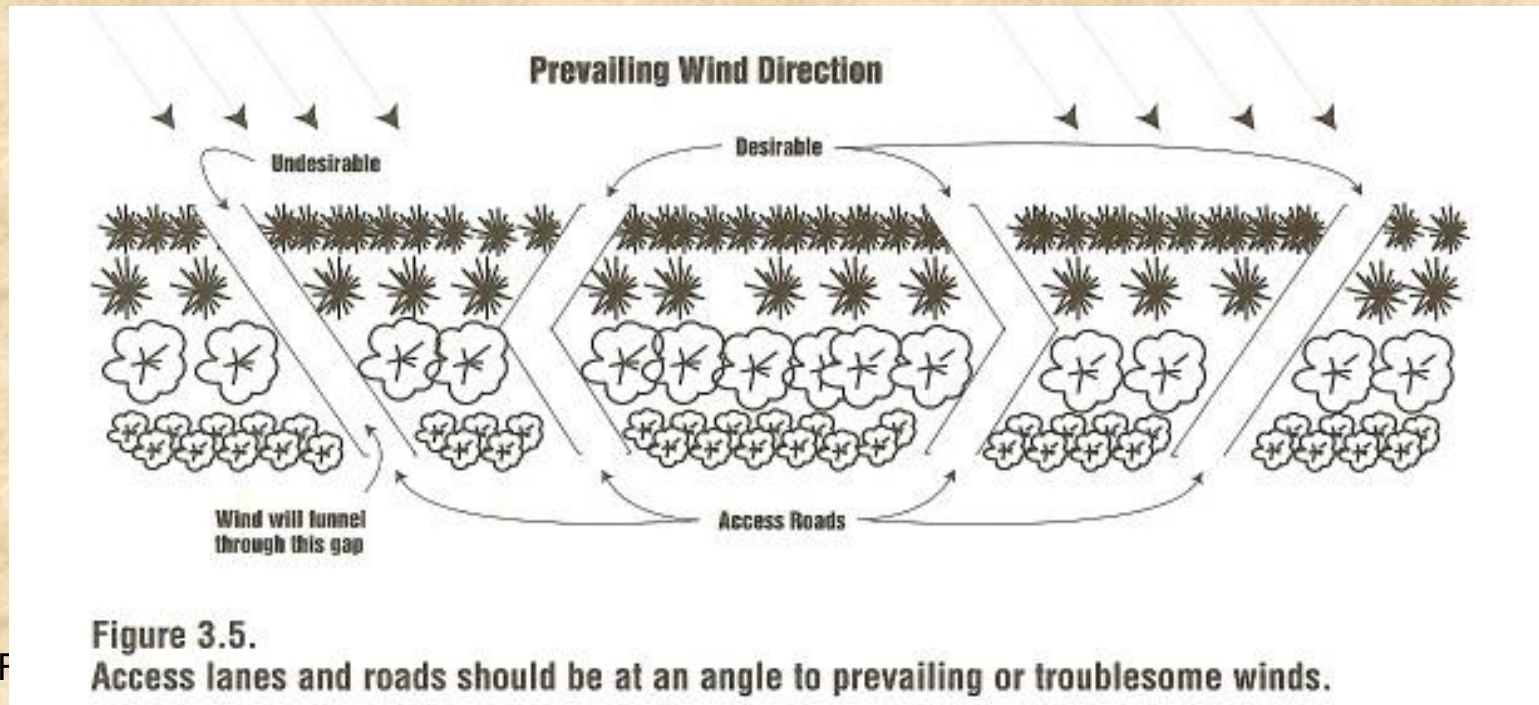

(Gullickson 1999)



Selecting Plants – Growth Characteristics



02/19/2007



**Open wind speed 20 M.P.H.
Deciduous 25%–35% density**

H distance from windbreak	5H	10H	15H	20H	30H
Miles per hour	10	13	16	17	20
% of open wind speed	50%	65%	80%	85%	100%



**Open wind speed 20 M.P.H.
Conifer 40%–60% density**

H distance from windbreak	5H	10H	15H	20H	30H
Miles per hour	6	10	12	15	19
% of open wind speed	30%	50%	60%	75%	95%



**Open wind speed 20 M.P.H.
Multi-row 60%–80% density**

H distance from windbreak	5H	10H	15H	20H	30H
Miles per hour	5	7	13	17	19
% of open wind speed	25%	35%	65%	85%	95%



**Open wind speed 20 M.P.H.
Solid fence 100% density**

H distance from windbreak	5H	10H	15H	20H	30H
Miles per hour	5	14	18	19	20
% of open wind speed	25%	70%	90%	95%	100%

Figure 31. Windbreak density influences the leeward wind protection zone.

Optical Density

◆ Optical Density

- The amount of area composed of solid material (porosity is the amount of open area that is **not** covered in solid material)
- For deciduous woody plants this is all stem and branch material
- For conifers this includes foliage
- Solid barrier is 100% density (0% porosity)

◆ Vary density by species selection, spacing, management, number of rows

◆ Living snow fences with high density >65% will generally have narrower drift patterns

(PNW 2003)



Effect of Density and Height

- ◆ Density and height of snow fences influence the storage capacity and drift size and shape
- ◆ Can vary this feature with species selection, number of rows, spacing and other management decisions

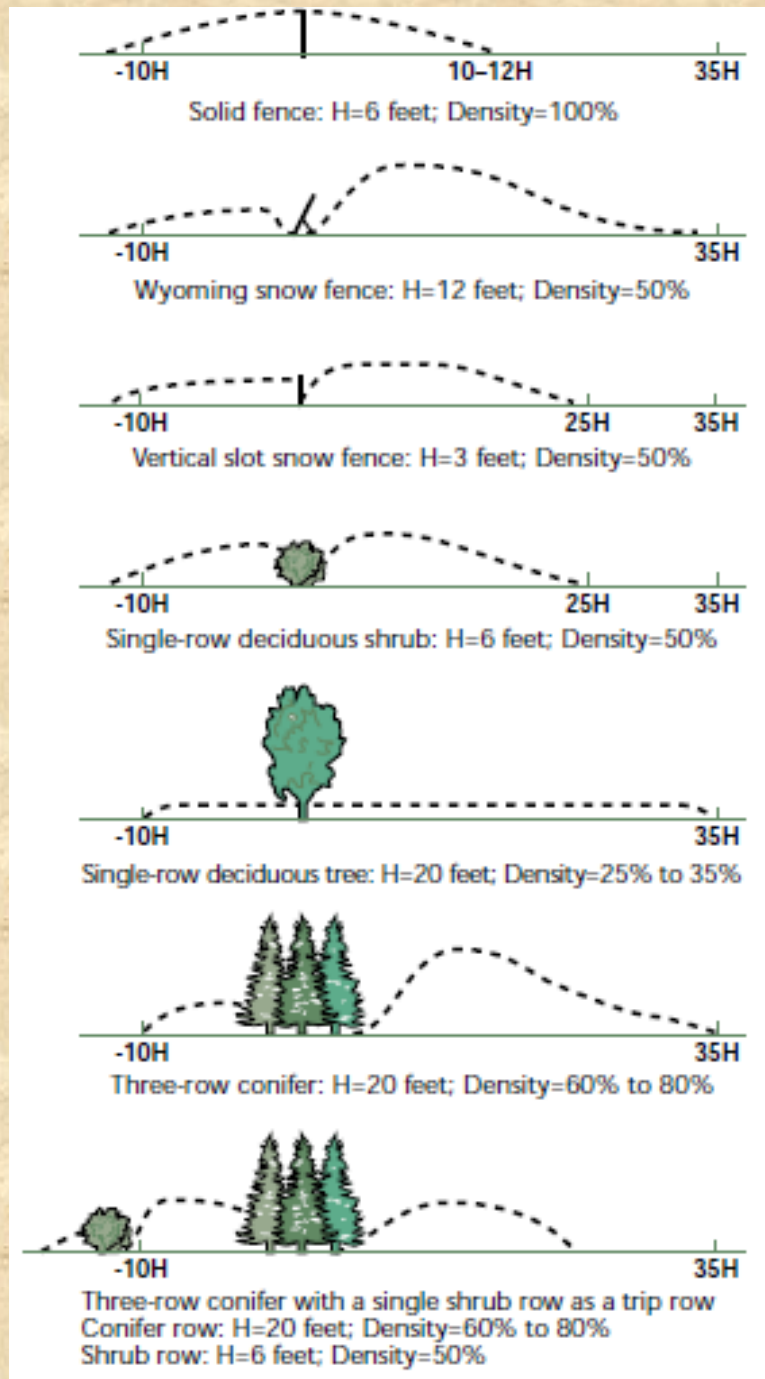



Selecting Plants – Plant Characteristics Change Over Time

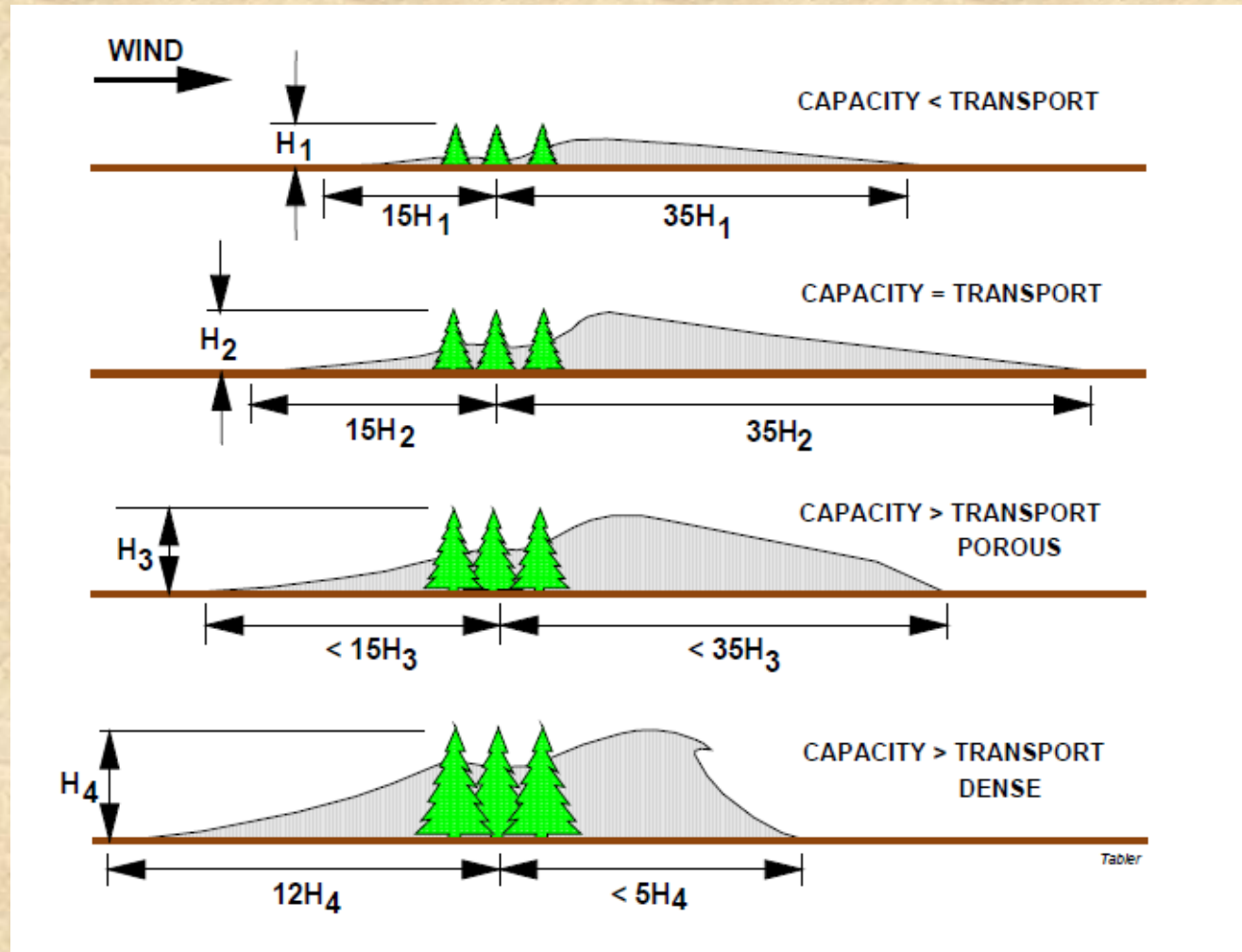



One Year Old Coppice Growth on a Two Year Old Root System – Single Row



Fish Creek - Density - 47.5%



SV1 - Density – 23.7%



Two Year Old Coppice Growth on a Three Year Old Root System – Single Row

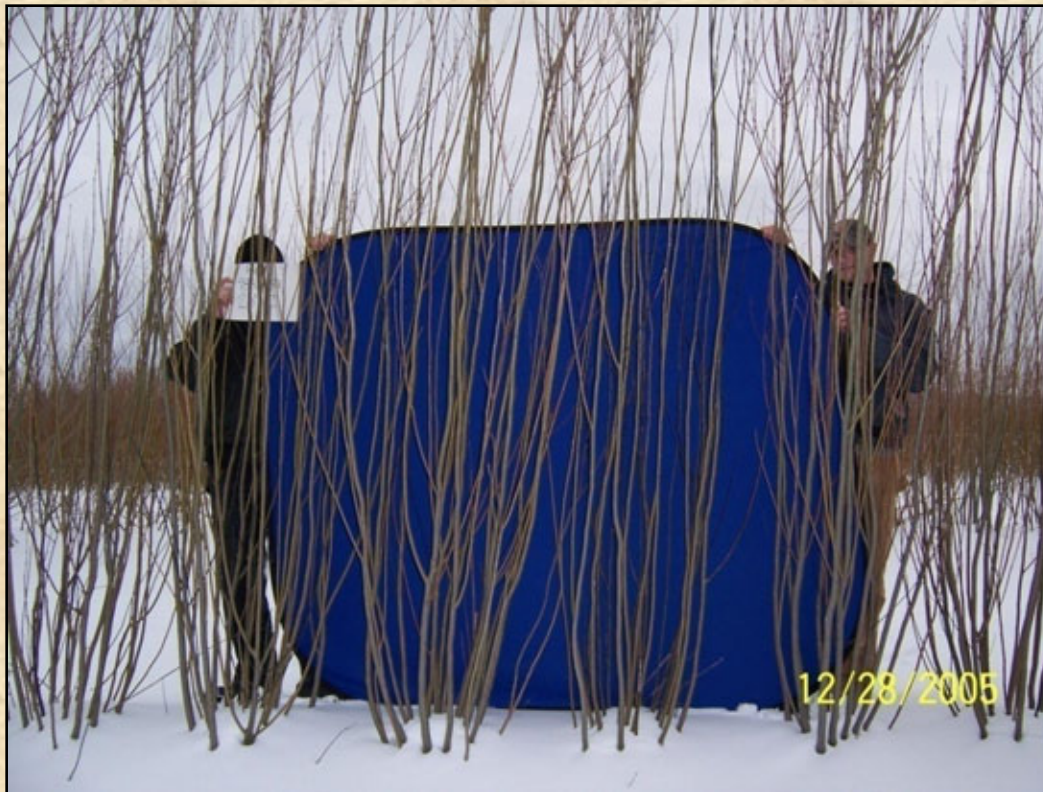

Fish Creek - Density – 50%



SV1 - Density – 53%

Snow Break Forests

- ◆ Dense plantings that act as a solid barrier can be planted closer to the road
- ◆ Shade from plants may effect road conditions
- ◆ Drifts may occur as plants are developing

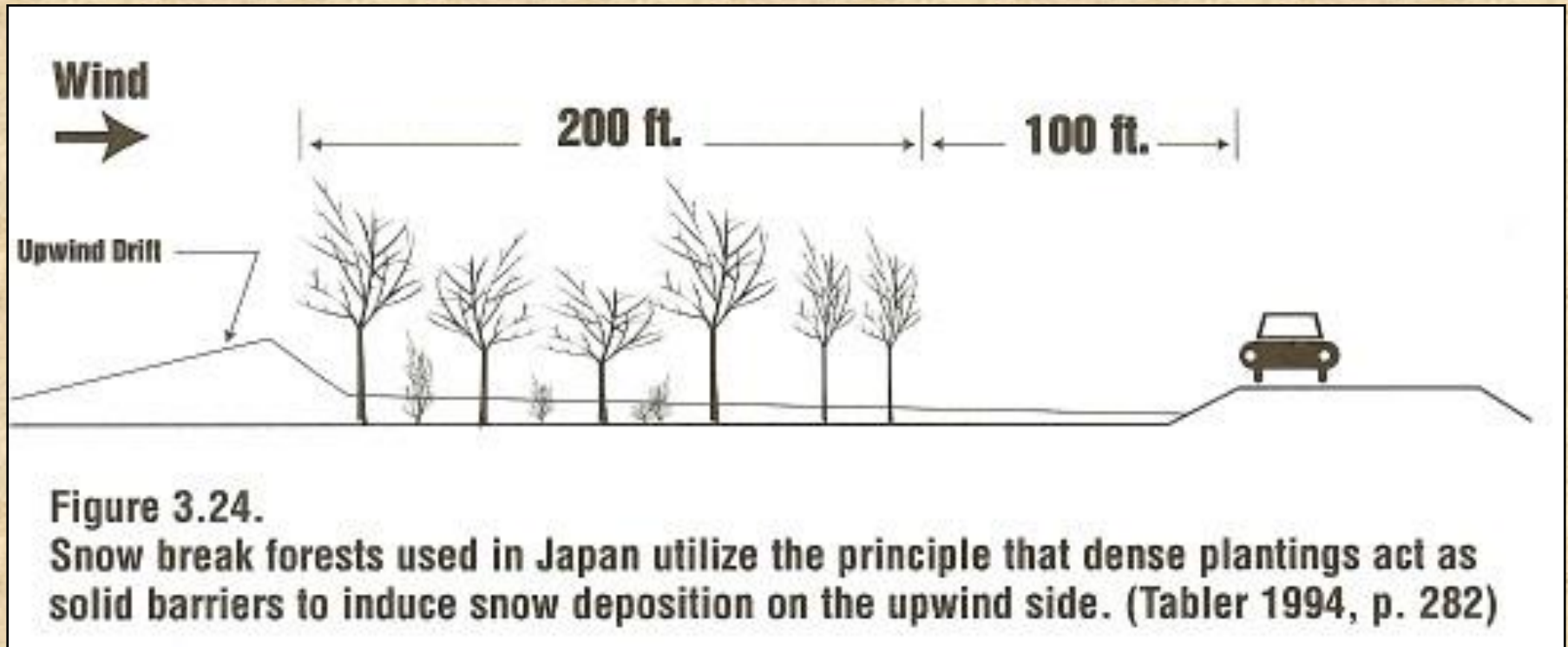



Selecting Plants – Growth Characteristics

- ◆ Ability to withstand wind
- ◆ Ability to withstand snow loads
- ◆ Native or non native
- ◆ Invasive
- ◆ Species longevity
- ◆ Salt tolerance
- ◆ Avoid plants for which a major pest or disease problem is known
 - Elms or hybrid poplar in our region
- ◆ Canopy width to facilitate maintenance and avoid problems with utilities

Beneficial Willow Characteristics



20 inch willow cutting planted in a living snow fence

- ◆ Easy to establish with unrooted cuttings
 - Easier to handle
 - More tolerant of delays in the field
 - Cheaper than rooted stock
- ◆ Tolerates planting at high density (1.5 – 2 ft spacing)

Beneficial Willow Characteristics



Measuring optical density on a living willow snow fence in Cortland County, NY

- ◆ Rapid height growth
 - Can reach >20 ft in 3-years
 - Can reach 50% density in 3 years
- ◆ Larger planting stock can be used to accelerate establishment
- ◆ Effective in as little as two to three years

Beneficial Willow Characteristics



Willow (*S. purpurea*) living snow fence five months after coppicing

- ◆ Coppicing ability creates good density from the ground to top of the crown
 - Mature willow snow fence has a measured density of 60-70%
- ◆ Once established, maintenance is minimal
- ◆ Height and density can be modified by selecting willow varieties and changing spacing and/or management



Species/Variety Selection

Living Snow Fences Species Matrix for New York State



Justin P. Heavey
Timothy A. Volk

Forest & Natural Resource Management
SUNY ESF

Syracuse, NY
2012



Site/Plant Selection



March 2010



This variety of willow was damaged during the first winter by snow drifts that formed due to topographic features at this site.



Site/Plant Selection



First year willow clone breaking under snow load at 81S site near Tully





Route 81S Near Tully, NY



➤ Concern about snow drift forming around the end of the living snow fence



Installation and Maintenance of Living Snow Fences



Successful Living Snow Fence Installation

- ◆ Keys for successful installation of living snow fences
 - Proper site preparation based on good site assessment
 - Careful installation of plants
 - Control of grass and broadleaf weeds for 2-3 years after planting



Site Preparation

- ◆ Site preparation is a one time investment that influences the effectiveness of the living snow fence for years or decades
 - Take the time, make the effort, do it correctly!
- ◆ An important rule for successful living snow fence establishment is to address weed problems and soil limitations during site preparation **BEFORE** the living snow fence is planted
- ◆ Controlling weeds or modifying site conditions after planting is more costly and time consuming!



Site Preparation

- ◆ Benefits of proper site preparation
 - Control of existing weed pressure
 - Initial control of future weed pressure to minimize future maintenance costs and damage to plants in the living snow fence
 - Improve soil structure in rooting zone
 - Expand soil volume for rooting
- ◆ Results
 - More effective establishment
 - Reduced maintenance efforts and costs
 - Increased growth rate resulting in shorter time for living snow fence to be effective



Weed Control

- ◆ Weeds compete for moisture, nutrients and light
- ◆ Keep Weeds Back: Maintain a weed free area 2-3 ft away from where plants are placed
- ◆ Control weeds for 2-3 year establishment period



Site Preparation Flow Chart



Site Preparation - Mechanical

- ◆ Cultivation to reduce competition of existing grasses and prepare the soil for planting
 - Subsoiling, disking, rototiller
 - Will not provide long term control of perennial vegetation

- ◆ Disturbs the soil
 - Increase soil permeability and aeration
 - Reduce or remove barriers limiting plant growth
 - Increases soil volume for roots to acquire nutrients and water



Mechanical Site Preparation





Site Preparation - Mechanical





Site Preparation - Chemical

- ◆ Herbicides to control competing vegetation before planting
 - If possible this is best done in the late summer or early fall prior to planting
 - Chemical control of existing perennial vegetation is not as effective in the spring
 - Limitations and restrictions on herbicide use
 - Follow label guidelines



Site Preparation - Chemical



One-year old willow snow fence with weed & deer browse problems in western NY



Establishing a living snow fence in Cortland County in the spring of 2001.

- ◆ Good weed control for the first two years
 - Herbicides for Site Prep fall before planting
 - » glyphosate (Round Up - Touchdown)
 - 2 lbs. a.i./Acre
 - Depending on weeds present may also add following in a herbicide mixture:
 - » 2,4-D @ .5 – 1 lb a.i./Acre
 - » dicamba (Banvel) @ .5 – 1 lb a.i./Acre
 - » Mixture of 2,4-D and triclopyr (Crossbow) (.5 – 1 lb a.i./A and ¼ - ½ lb a.i./A)
 - Herbicides for Site Prep in spring of planting
 - » glyphosate (Round Up - Touchdown)
 - ◆ 2 lbs. a.i./Acre



Existing Vegetation – Woody Plants

- ◆ Bush hog then apply appropriate herbicide
- ◆ Stumps less than 3” can usually be removed during tillage operations
- ◆ Stumps >3”
 - Remove if only a few
 - Incorporate plants into the living snow fence



Existing Vegetation – Herbaceous

- ◆ **Brush** hog if greater than 10-12 inches tall because effectiveness of herbicide will be limited
- ◆ Determine type of vegetation
 - Perennial – herbicide and mechanical cultivation
 - » Check efficacy of post emergent herbicides after use by inspecting above and below ground plant parts
 - » Retreat sections that were missed or where herbicide was not effective
 - Annual – mechanical cultivation alone may be effective



Existing Vegetation – Agricultural Crop

- ◆ If actively used for cropping then ask for list and rates of recent herbicides used
- ◆ Some herbicides have a carry over effect and can influence establishment of new plants
- ◆ Annual crop – mechanical tillage
- ◆ Perennial crop – chemical and mechanical control



Post Planting Weed Control

- ◆ No method provides 100 percent guarantee
- ◆ Periodic monitoring of site is necessary
- ◆ Be prepared to respond quickly to weed pressure before it becomes a serious issue
 - i.e. smaller weeds are easier to control and will have less effect on the plants you are trying to establish



Post Planting Weed Control – Mechanical

- ◆ Mechanical cultivation
 - Various types of equipment are available
 - » Disks
 - » Spring tooth harrows
 - » Cultivators
 - » Specialized cultivators
 - Work best on young weed seedlings that are not well established
 - Less aggressive cultivation will not be effective on perennial weeds



Post Planting Weed Control – Mechanical

- ◆ Mowing of adjacent weeds
 - Important for areas beyond immediate 2-3 foot zone around living snow fence plants
 - Will not effectively reduce weed competition for water and nutrients in the immediate zone around establishing plants



Post Planting Weed Control- Mechanical (Mowing)

- ◆ Mowing is the preferred method of mechanical weed control
 - Timing is essential and hard to ensure
 - 3 – 5 mowings per year required for effective control
 - Care should be taken when mowing close to willows
 - Difficult to mechanically control weeds in between plants
 - » Often requires manual weed control to be effective



Post Planting Weed Control - Chemical

- ◆ Can be effective in combination with proper site preparation
- ◆ Requires proper selection and use of herbicide
- ◆ Monitoring still required to ensure that weed control goals are being met



Post Planting Weed Control - Premergence



One-year old willow snow fence with weed & deer browse problems in NY



Establishing a living snow fence in Cortland County in the spring of 2001.

© The Research Foundation of SUNY

◆ Proper follow up weed control after planting is essential for success

– Pre-emergence herbicides:

- » oxyfluorfen (Goal)
- » simazine (not in sandy soils)
- » pendimethalin (Prowl – Pendulum)

– Other pre-emergence herbicides that are less tested

- » norflurazon (Solicam)
- » flumioxazin (Sureguard)
- » imazaquin (Scepter)



Post Planting Weed Control – Post Emergence



One-year old willow snow fence with weed & deer browse problems in NY

◆ Proper follow up weed control after planting is essential for success

– Post-emergence herbicides:

» clopyralid (Stinger) (not in Nassau & Suffolk Counties – max of .25 lb a.i./A/year in NY)

» Any grass only herbicide

◆ Fusilade or Poast, etc.



Establishing a living snow fence in Cortland County in the spring of 2001.



Post Planting Weed Control – Organic Mulches

- ◆ Can help with weed control but will need to be maintained over time if it is the primary weed control method
 - Annual addition of mulch as material degrades and weeds become established on the surface
- ◆ Additional benefits include
 - Moisture retention
 - Moderated soil temperatures which can potentially extend root growth into the fall but slows soil warming in the spring



Post Planting Weed Control – Organic Mulches

- ◆ Wood chips are the preferred mulch
 - 3 – 4 inch layer of chips
 - If possible the lower layer should be composted
- ◆ Limitations
 - Potential to introduce more weed seeds
 - May enhance rodent damage in the winter
 - Labor cost associated with spreading mulch

Post Planting Weed Control – Landscape Fabric



Establishing a willow living snow fence in Lewis Co., NY in the spring of 1999.

- ◆ Can be effective for 1 – 6 years or more depending on type of fabric and use
- ◆ Mats or rolls available
- ◆ Recommended width is 6 ft, but comes in 3 – 6+ ft widths
- ◆ Try to select material that has a projected lifespan of 3 – 5 years
- ◆ Poly-fabrics last much longer than biodegradable fabrics, but can cause several problems

Fabric Barrier

Fabric Advantages

- ◆ Applied only once
- ◆ Improved tree and shrub establishment and survival
- ◆ Increases growth rates immediately following planting
- ◆ Easier and more timely weed control
- ◆ Long lasting weed control
- ◆ Comparable cost to other weed control methods averaged over several years

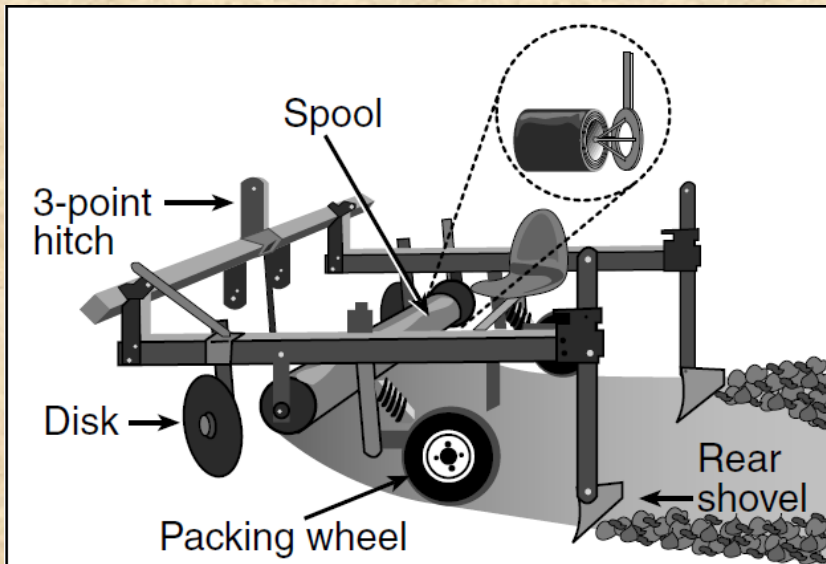

Figure 1. Fabric mulch dispensing machine.

Fabric Barrier

◆ Fabric Disadvantages

- Initially expensive
- Requires specialized machinery to install or done by hand
- Proper installation is critical to prevent pulling loose in winds
- Does not break down, especially within the shade of plants or under mulch
- Stems may be girdled by fabric as trees and shrubs grow
- Dense sod can become established on top of fabric, negating benefits and complicating future maintenance
- Ideal habitat for ground hogs, voles and mice



(PNW 2003)



Post Planting Weed Control – Landscape Fabric

- ◆ Should remove or till in weeds before use
- ◆ Fabric needs to be secured at time of installation to avoid abrasion of planted material
 - Plastic pegs, cover edges with soil (but will promote weed growth), cover with mulch
- ◆ Create openings in fabric using X-shaped cuts to avoid girdling as plants grow



Post Planting Weed Control – Landscape Fabric

- ◆ Improper installation can result in significant damage to plants
 - Broken stems and braches
 - Girdling from abrasion
 - Plants covered and smothered
 - Excessive temperatures under the fabric



Post Planting Weed Control – Landscape Fabric

- ◆ Can be very effective and beneficial
- ◆ BUT
 - When installed improperly it can cause extensive damage







Fabric Barrier Recommendations



Large X shaped openings in the fabric are important for the long term success of the living snow fence

Fabric Management

- ◆ Inspect as part of monitoring in first 1 – 2 years
- ◆ Ensure edges are firmly anchored
- ◆ Ensure openings are large enough to avoid stem damage
- ◆ Control aggressive weeds that may establish in fabric openings
- ◆ Enlarge openings as needed to prevent stem girdling
- ◆ Cover with mulch but leave area immediately around plants uncovered

Mulch



Thistles growing in area mulched with wood chips but not elsewhere. Probably introduced in wood chips.

- ◆ Try to use wood chips that have been stored for a short period of time and are not mixed with soil
- ◆ Decomposed wood chips or some sources of mulch have the potential to introduce new weeds onto the site



Paper Barrier Recommendations

- ◆ Use paper or biodegradable fabric that will break down in 1-3 years
- ◆ Needs to be strong enough to provide at **least** one year of effective weed control
- ◆ Avoids problems associated with girdling and root development
- ◆ Easy to plant through
- ◆ Currently more costly than traditional landscape fabric, but options being pursued



Paper or Biodegradable Weed Barrier





Planting Stock

When planting living snow fence, have two choices:

- ◆ Rooted planted stock or
- ◆ unrooted cuttings



Planting Rooted or Balled Stock

- ◆ Different types available
 - Bare root or plug (balled trees)
- ◆ Small sized material is lower cost and easier to handle and plant
- ◆ Available from
 - Commercial nurseries
 - DEC Tree Nursery or
 - Soil and Water Conservation Districts



Planting Rooted Stock





Planting Rooted Stock

- ◆ Proper care of rooted stock is essential
 - Keep plants moist and in a cool location
 - Roots must never dry out!
- ◆ Make the hole deep enough for all roots.
- ◆ Cut long roots back to 10 or 12 inches.
- ◆ Remove one tree at a time from bucket only after hole is ready for the tree.
- ◆ Keep foreign matter (leaves, sticks, rocks, and dry soil) out of hole.
- ◆ Place all tree roots in a downward position.
- ◆ Place tree in center of hole.
- ◆ Hold treetop upright while working soil around roots.

(adapted from PNW 2003)



Planting Rooted Stock

- ◆ Firm soil around roots by hand while filling hole, leaving no air spaces. Make sure to use moist soil.
- ◆ Bring soil level to root collar (look for color change on stem) above the first roots. Too deep is better than too shallow.
- ◆ Firm soil all around tree by hand to give good compaction.

(adapted from PNW 2003)

Planting Rooted Stock

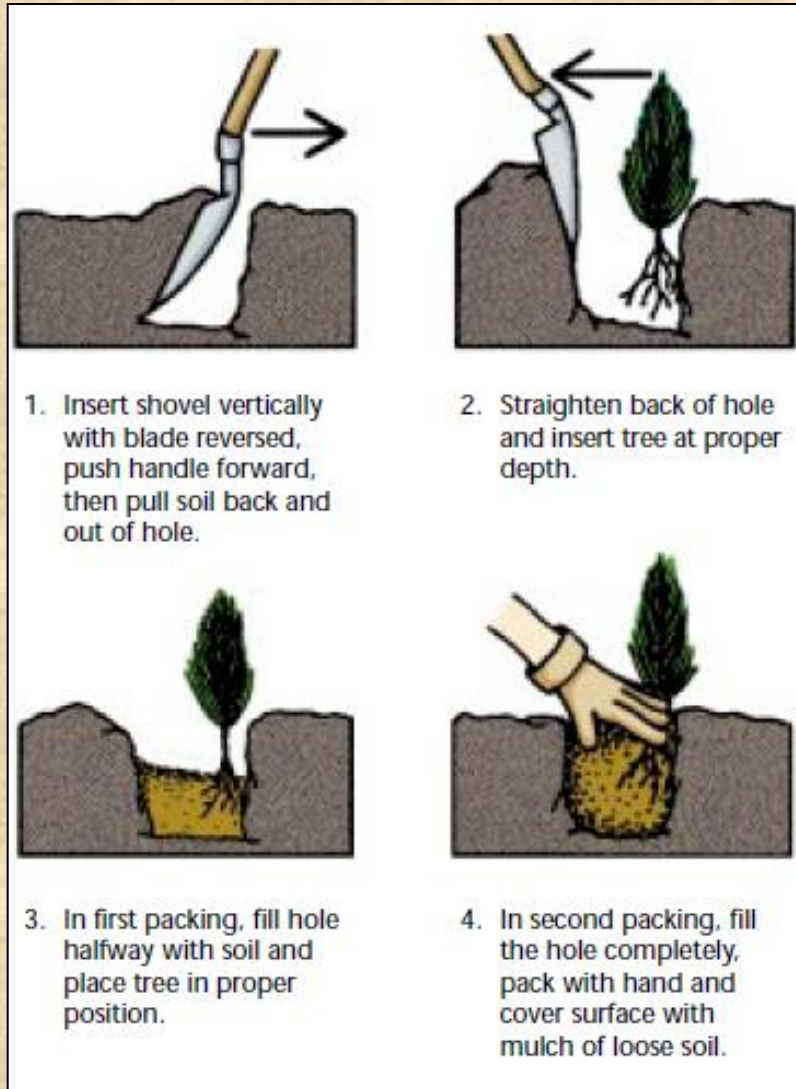

- ◆ Trees and shrubs planted improperly have little chance to survive.
- ◆ Take an extra moment with each plant, to make sure they are planted properly

(adapted from PNW 2003)

Proper Planting is Essential

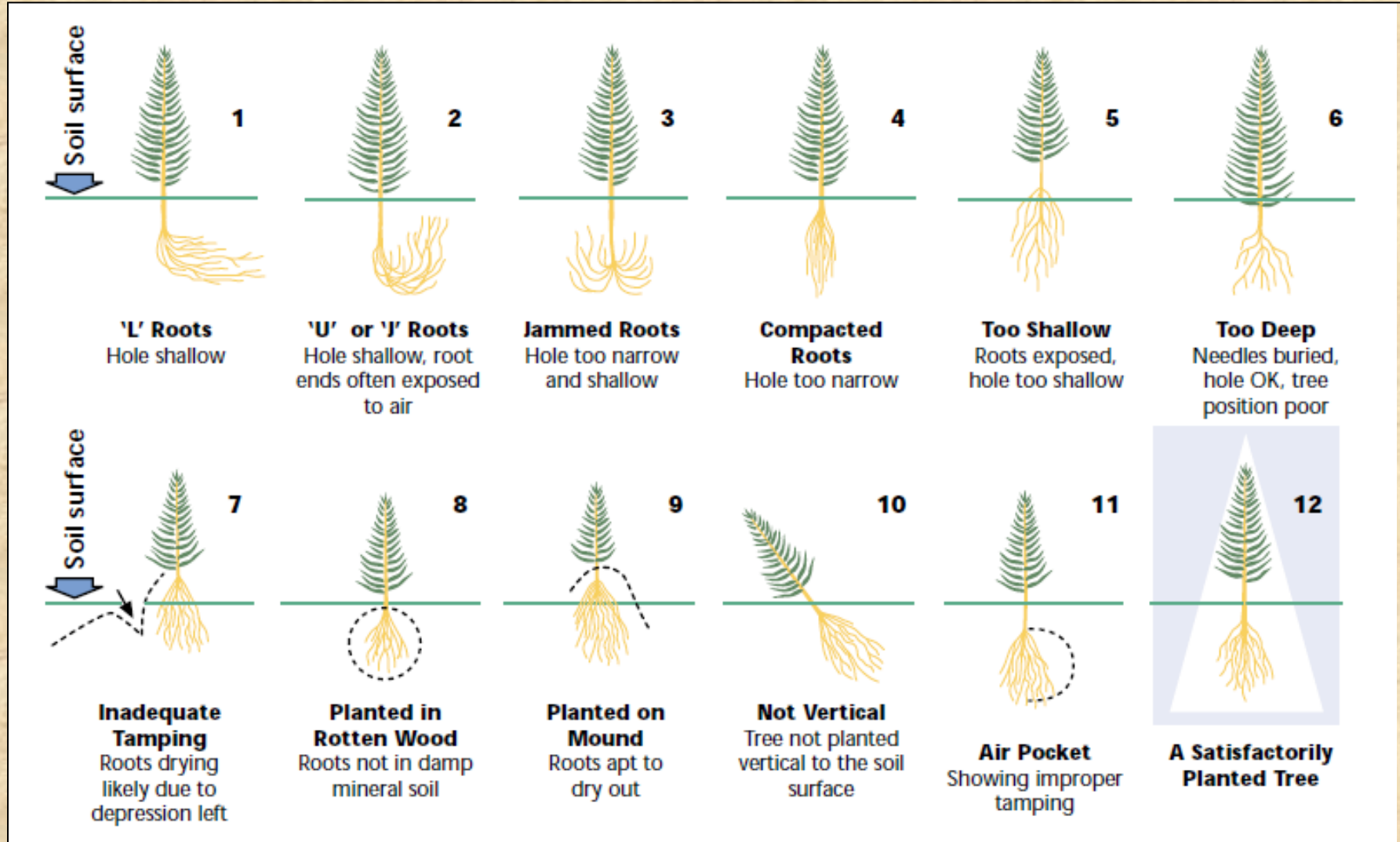



Planting – Unrooted Cuttings

- ◆ Used for establishing willow and hybrid poplar
- ◆ Lower cost and easier to handle
- ◆ Quality of material is important
- ◆ Recommend 10 – 20” cuttings
- ◆ Keep frozen until just before planting
- ◆ Store in cool location and do not allow them to dry out after being delivered
- ◆ Plant with buds pointing up with at least one bud above ground

Planting – Unrooted Cuttings



Planting of unrooted hardwood cuttings is easy and relatively quick

- ◆ Plant 10 to 20 in. long cuttings between late April and late May
- ◆ Use high quality planting stock that has been properly stored and cared for

Post Planting Care



Weed control is probably the single largest factor for the failure of living snow fences

- ◆ Regular monitoring is needed to quickly identify problems before they become serious issues
 - Weed pressure
 - Deer browsing damage
 - Pest and disease problems
 - Herbicide damage from improper use or drift
 - Other factors that may be limiting growth



Post Planting Care

- ◆ Weed control will be necessary for 2-3 seasons at least
 - Longer for sites where growth of shrubs or trees is slow
- ◆ Replanting
 - Even under the best conditions some plants will not survive
 - Gaps will create additional problems in the future
- ◆ Browsing control
 - At some locations deer browsing pressure can severely limit growth of plants
 - Recommend the use of deer repellent early to discourage deer from developing browsing habit



Deer Control

◆ To be added



Post Planting Care

- ◆ Coppicing
 - For willows coppicing after the first year of growth is recommended to promote the development of multiple stems
- ◆ Fertilizer may be applied after the plants are established
 - Fertilizer on young or poorly established plants will just feed the weeds
 - Spring application of fertilizer based on soil analysis or plant tissue analysis
 - If uncertain, ask Maintenance Environmental Coordinator for advice on fertilizing.

Successful Installations



Willow snow fence three months after planting.



First year of growth after coppicing

Successful Installations



Willow snow fence two months after planting



Route 81S Near Tully, NY



- Planted May 2009
- Excellent initial survival
- Late July 2009



Route 81S Near Tully, NY



August 2009



Route 81S Near Tully, NY

March 2010





Route 81S Near Tully, NY



March 2010





Successful Installations





Successful Installations





Lessons Learned/Shared Experiences



Field Installation Activities



Willow Snow Fence Installation Rt. 12 - Paris NY, May, 2012



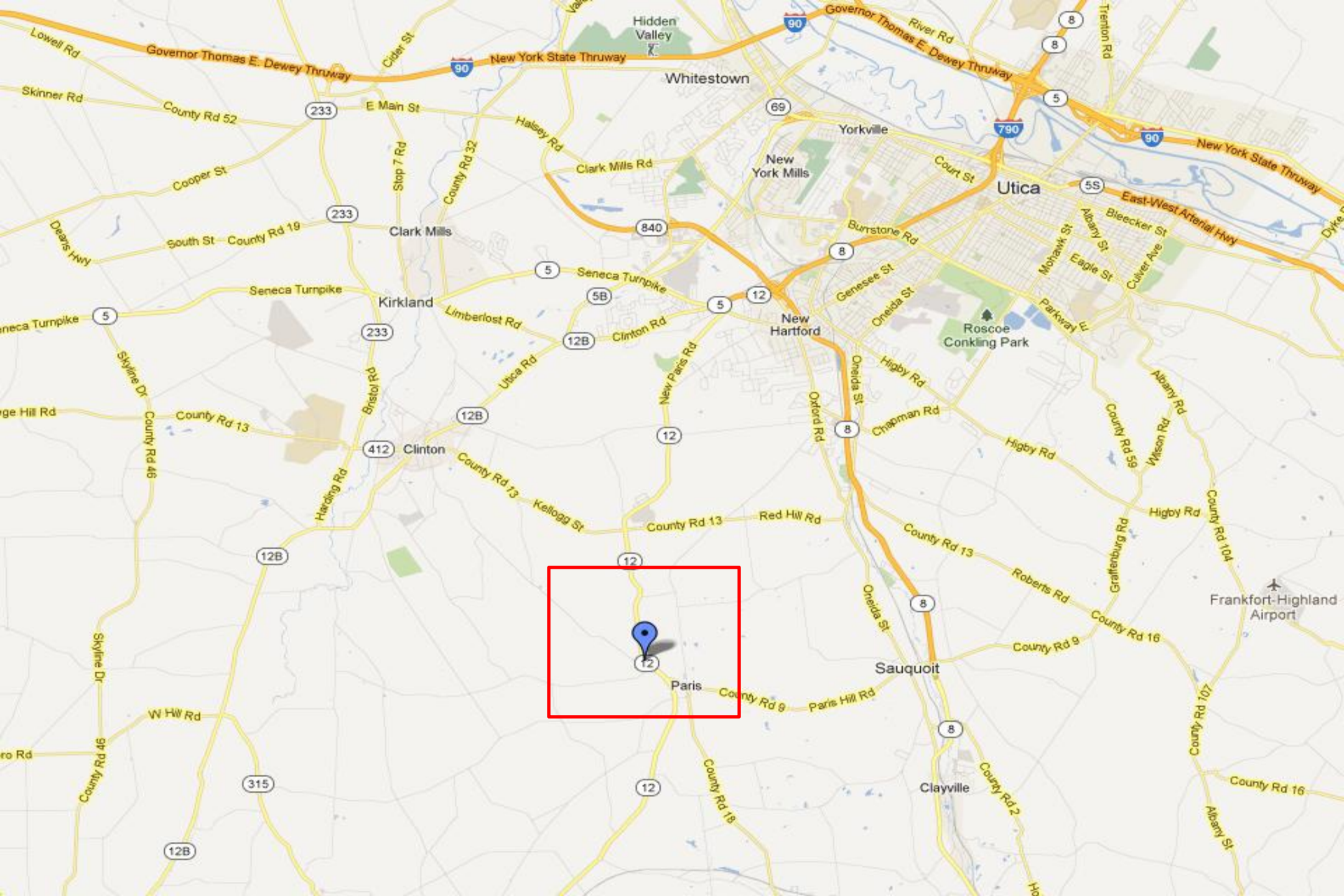

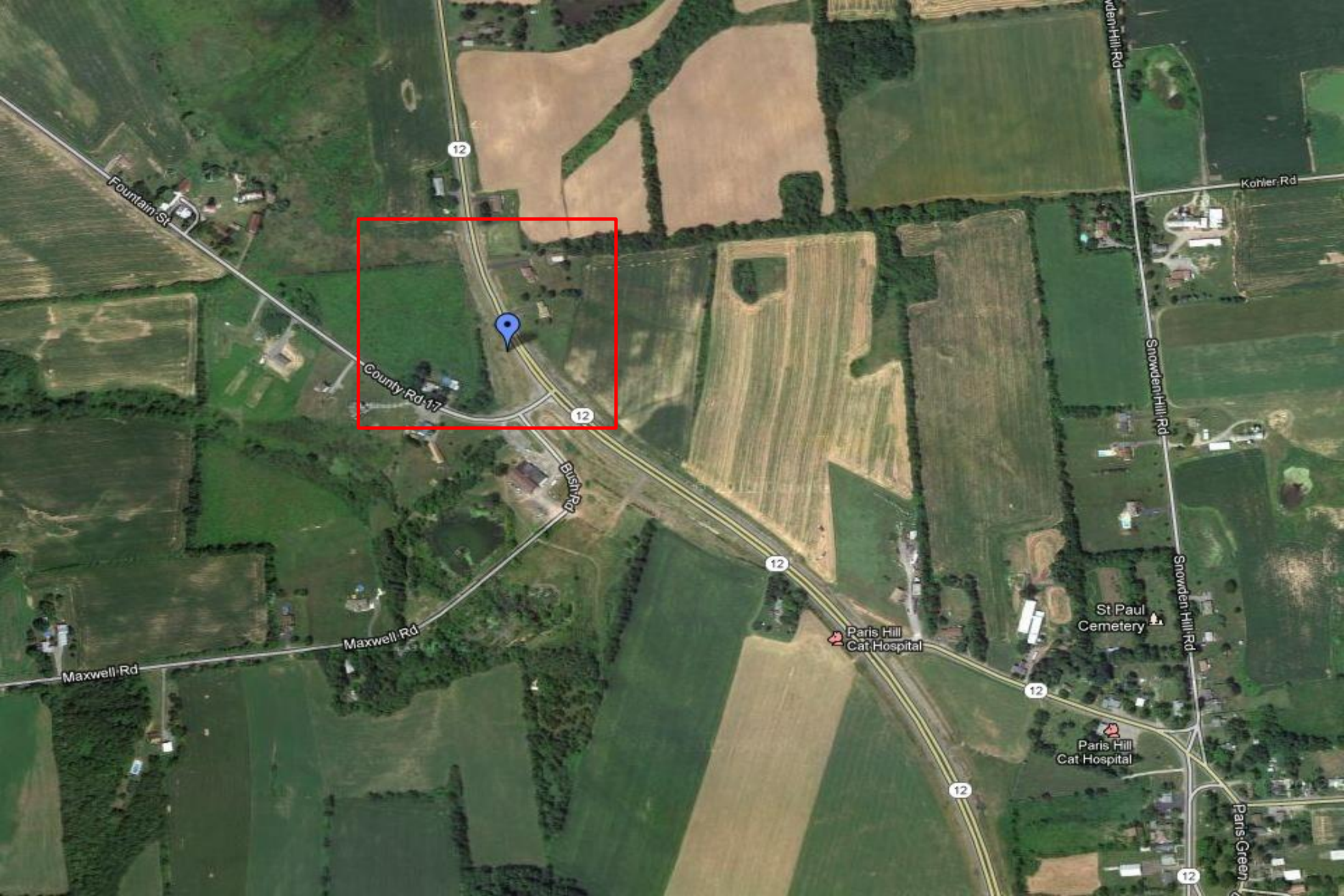

12

Fountain St

County Rd 17

12

Busby St

12

Maxwell Rd

Maxwell Rd

Paris Hill
Cat Hospital

St Paul
Cemetery

Snowden Hill Rd

Kohler Rd

Paris Hill
Cat Hospital

12

Paris Green

12

Site Limitations and Challenges

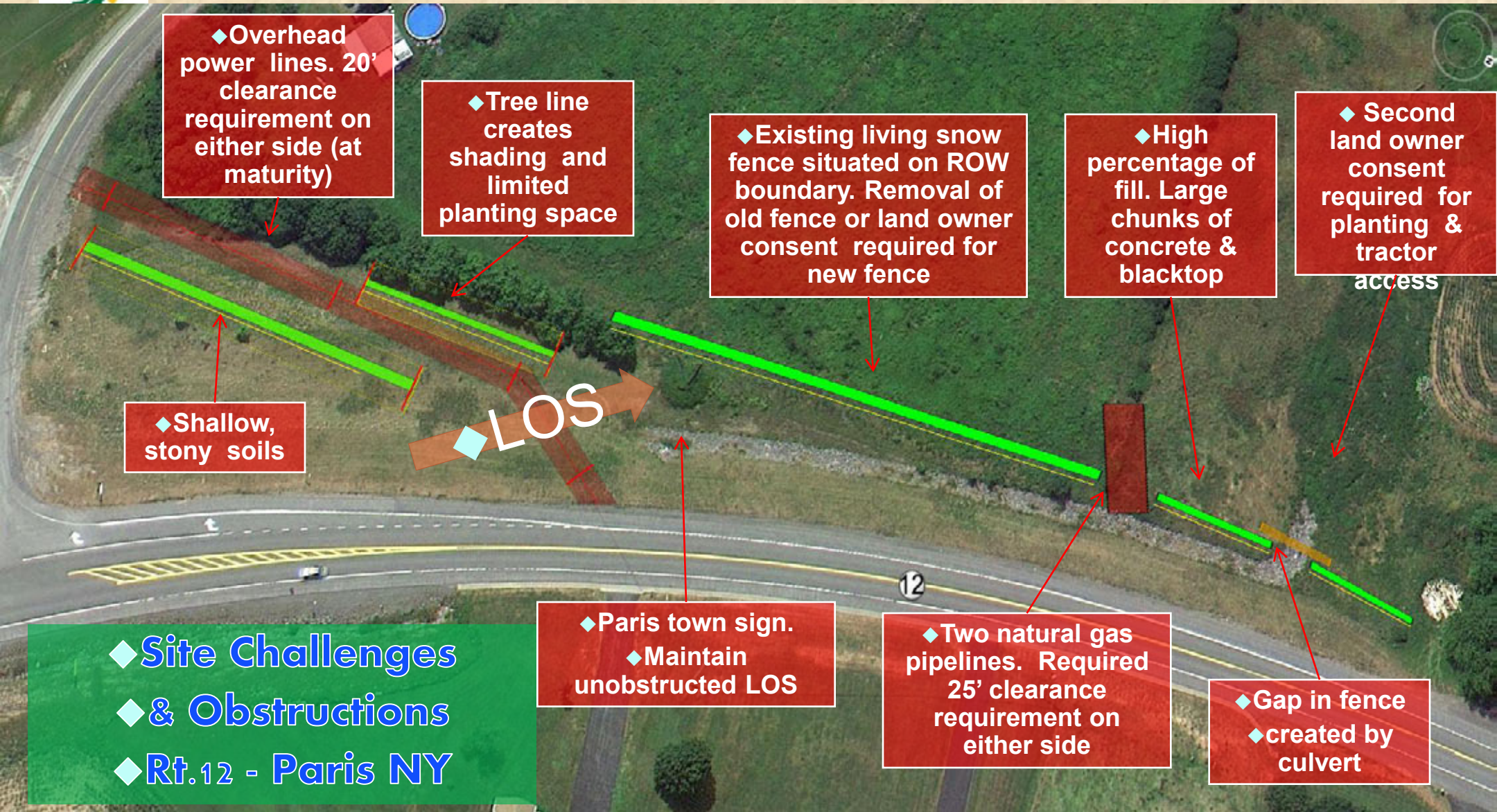

◆ Overhead power lines. 20' clearance requirement on either side (at maturity)

◆ Tree line creates shading and limited planting space

◆ Existing living snow fence situated on ROW boundary. Removal of old fence or land owner consent required for new fence

◆ High percentage of fill. Large chunks of concrete & blacktop

◆ Second land owner consent required for planting & tractor access

◆ Shallow, stony soils

◆ LOS

◆ Paris town sign.
◆ Maintain unobstructed LOS

◆ Two natural gas pipelines. Required 25' clearance requirement on either side

◆ Gap in fence
◆ created by culvert

◆ Site Challenges
◆ & Obstructions
◆ Rt.12 - Paris NY



Working with Site Conditions

- ◆ Tree line (shade)
- ◆ Existing snow fences
- ◆ Utilities (electric & gas)
- ◆ Rocky soils & fill
- ◆ Paris town sign
- ◆ Ditches, etc.





Living Snow Fence Design

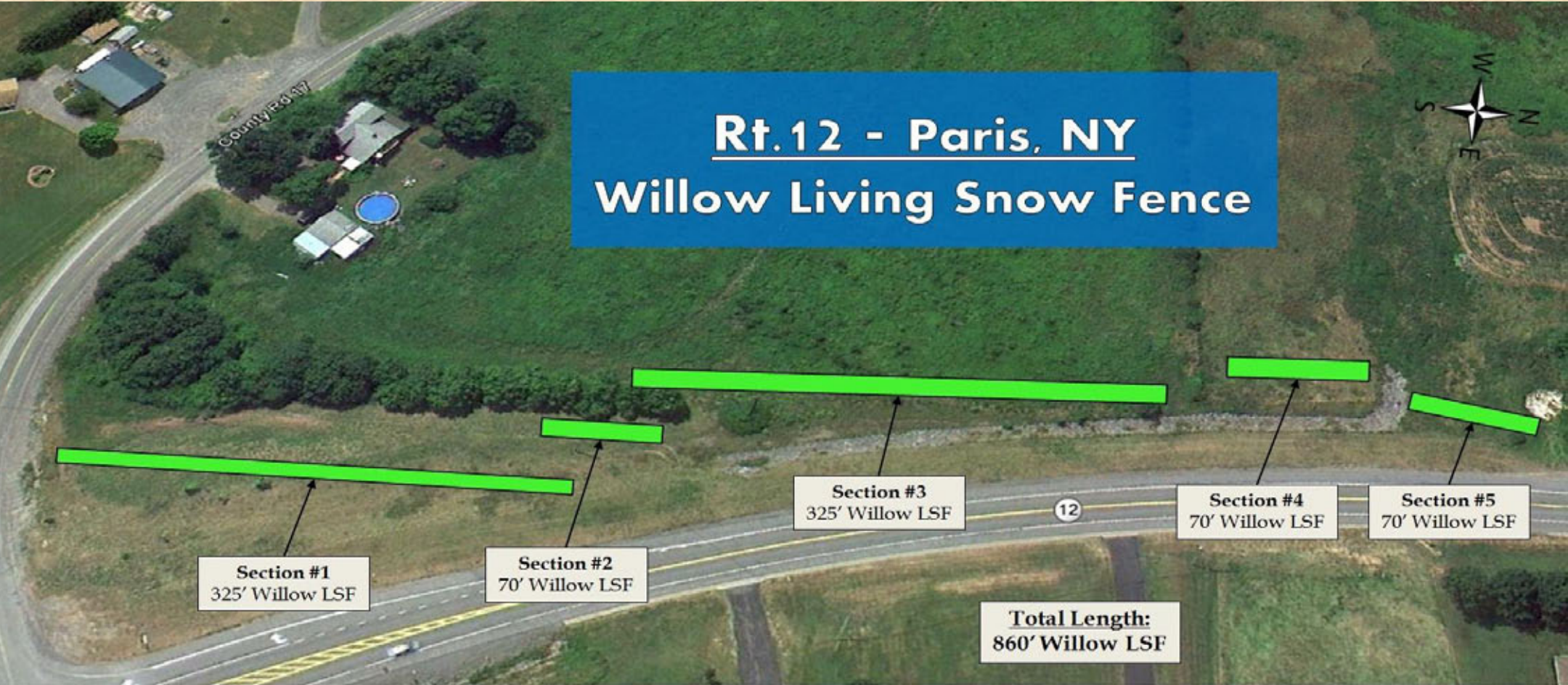



Site Preparation

- ◆ Sprayed site to kill existing vegetation
- ◆ Subsoiled site due to concerns about restrictive layers
 - One section with concrete and asphalt fill created additional site preparation problems
- ◆ Amended soil in one section
- ◆ Rototilled site and laid paper landscape fabric



Site Preparation – Rip soil





Site Preparation – Rototill





Site Preparation – Add Soil Amendments





Site Preparation – Lay Paper Fabric



05.23.2012



Site Preparation – Secure Fabric





Site Preparation

- ◆ Mark landscape fabric for planting with willow cuttings
 - 2.5 ft between double rows
 - 2 ft along the rows in a staggered design
 - Result is a plant about every foot
 - Plant directly through paper material



Planting

- ◆ Plant 20 inch long cuttings for most of the site
- ◆ Add mulch and spread to a depth of 2-3 inches
 - Be sure to cover or secure the fabric so it does not get picked up by the wind

Follow Up Monitoring and Maintenance



Weed pressure beginning to build at a new living snow fence

- ◆ Important to regularly monitor new plantings for weeds, deer browsing, other problems
- ◆ Early action to correct problems is much easier than trying to address it later



Site Preparation and Installation Summary

- ◆ Decisions early in the design and installation process have a long term effect
- ◆ Select the plants most suited for the site conditions and goal of the living snow fence
- ◆ Proper site preparation is essential and will provide benefits for years in the future
- ◆ Weeds are the largest challenge but can be managed using a variety of techniques

Questions and Discussion



"We cannot keep it from snowing, but we can influence the wind that carries tons of blowing and drifting snow" – Gullickson et al. 1999.