

## The College at Brockport: State University of New York Digital Commons @Brockport

Chemistry Faculty Publications

Chemistry and Biochemistry

3-2000

# Short-Pathlength, High-Pressure Flow Cell for Static and Time-Resolved Infrared Spectroscopy Suitable for Supercritical Fluid Solutions Including Hydrothermal Systems

Markus M. Hoffmann

*The College at Brockport*, [mhoffman@brockport.edu](mailto:mhoffman@brockport.edu)

R. Shane Addleman

*Pacific Northwest National Laboratory*

John L. Fulton

*Pacific Northwest National Laboratory*

Follow this and additional works at: [https://digitalcommons.brockport.edu/chm\\_facpub](https://digitalcommons.brockport.edu/chm_facpub)

 Part of the [Chemistry Commons](#)

### Repository Citation

Hoffmann, Markus M.; Addleman, R. Shane; and Fulton, John L., "Short-Pathlength, High-Pressure Flow Cell for Static and Time-Resolved Infrared Spectroscopy Suitable for Supercritical Fluid Solutions Including Hydrothermal Systems" (2000). *Chemistry Faculty Publications*. 4.

[https://digitalcommons.brockport.edu/chm\\_facpub/4](https://digitalcommons.brockport.edu/chm_facpub/4)

### Citation/Publisher Attribution:

Hoffmann, M. M.; Addleman, R. S.; Fulton, J. L. Short-Pathlength, High-Pressure Flow Cell for Static and Time-Resolved Infrared Spectroscopy Suitable for Supercritical Fluid Solutions Including Hydrothermal Systems. *Rev. Sci. Instrum.* 2000, 71, 1552-1556.

Available on publisher's site at <http://link.aip.org/link/doi/10.1063/1.1150493>.

This Article is brought to you for free and open access by the Chemistry and Biochemistry at Digital Commons @Brockport. It has been accepted for inclusion in Chemistry Faculty Publications by an authorized administrator of Digital Commons @Brockport. For more information, please contact [kmyers@brockport.edu](mailto:kmyers@brockport.edu).

# Short-pathlength, high-pressure flow cell for static and time-resolved infrared spectroscopy suitable for supercritical fluid solutions including hydrothermal systems

Markus M. Hoffmann, R. Shane Addleman, and John L. Fulton<sup>a)</sup>

*Environmental and Health Science Division, Pacific Northwest National Laboratory, Richland, Washington 99352*

(Received 11 October 1999; accepted for publication 23 November 1999)

An optical flow cell for high pressures and temperatures is described. The use of a novel window design allows for a precise, fixed optical pathlength that can be varied by use of spacers that range from a few micrometers to several millimeters. The cell pathlength is not affected by changes in pressure or temperature. The novel window design may be applicable to other high-pressure spectroscopic cells. The flow-cell design has a minimal sample dead volume, which is important for kinetic studies. The design eliminates the need for brazing or for a soft-sealing material for the optical windows, thereby minimizing the number of materials in contact with the sample. Using only diamond and platinum or platinum alloys as the corrosion resistant materials, the design is optimized for the study of aqueous solutions at high temperatures. Infrared spectra of an aqueous sodium tungstate solution up to 400 °C and 380 bar pressure are presented. Time-resolved infrared data are also presented for the ultraviolet photolysis reaction of  $\beta$ -naphthoyl azide in supercritical carbon dioxide. © 2000 American Institute of Physics. [S0034-6748(00)01503-3]

## I. INTRODUCTION

As discussed by Sherman and Stadtmuller,<sup>1</sup> most of the common high-pressure optical cell designs employ window seals that can be divided into three basic types. In the first two types, the Amagat and the Poulter seals, the pressurized sample forces the window to seal against an external retaining surface that is coned or flat, respectively. In the third type, known as the opposed-force (squeezer type) window seal, an outside force is applied on the window material, pressing the window against a sealing surface (and the pressurized sample). Sealing materials such as elastomers or a brazed joint are often used to facilitate the pressure seal between the optical window material and the retaining surface.<sup>2</sup> In these types of designs the pathlength is typically fixed. This means that if many optical cells have to be built, different pathlengths are desired. It is also technically very demanding to establish short pathlengths (smaller than 0.1 mm) and the sample dead volume is typically high. If the sample volume of a flow cell is large, a stirring mechanism may be incorporated to assure uniform fluid distribution.<sup>3</sup> However, extremely short pathlengths and hence ultrasample volumes are necessary for strongly absorbing systems, such as aqueous solutions in the midinfrared region—particularly in the low wave number region from 500 to 5000  $\text{cm}^{-1}$ . This may be a major reason why relatively few infrared (IR) studies of aqueous solutions to high pressures and temperatures exist. Reported cell designs of short optical pathlengths that are suitable for these systems include an opposed-force window seal design where a small groove in a spacer provides

ports for introduction of the aqueous sample,<sup>4</sup> a design that employs a brazing sealing material,<sup>5</sup> a design that is based on a Poulter-type seal,<sup>6</sup> and a reflectance-type IR cell.<sup>7</sup> In the last cell design, the pathlength is determined by the thickness of a spacer between the optical window and the mirror. Another reported IR cell design for supercritical  $\text{CO}_2$  systems incorporates a translatable internal mirror that allows for adjustable variable pathlength.<sup>8</sup>

An alternative method to establish small pathlengths with literally no sample dead volume is the use of high-pressure quartz capillaries.<sup>9,10</sup> While the capillaries are inexpensive, easy, and safe to use, the small cross section limits the signal-to-noise sensitivity and the nonuniform pathlength can only be varied within a small range of available inner capillary diameters. The solubility of quartz in high temperature aqueous solutions is high,<sup>11</sup> rendering the capillaries, as well as designs using fiber optics, not suitable for many aqueous high temperature systems. Other designs that utilize transparent pressure container walls were summarized by Sherman and Stadtmuller<sup>1</sup> and include free moving piston cells. One special case of an optical free piston cell is a “pillbox” design where a cylindrical transparent container is inserted into a second cylindrical transparent container.<sup>12</sup> While this design has a negligible sample dead volume, the optical pathlength is large and difficult to reproduce.

Here we present an optical cell design that overcomes the above shortcomings. The central design idea hinges on a specially prepared optical window that has two radially oriented holes to provide an inlet and an outlet for the flowing sample. While this central design idea may be utilized in many ways, we incorporated it into an optical cell that is suitable for IR measurements of aqueous solutions at supercritical conditions. Our choice of materials for this optical

<sup>a)</sup>Author to whom correspondence should be addressed; electronic mail: john.fulton@pnl.gov

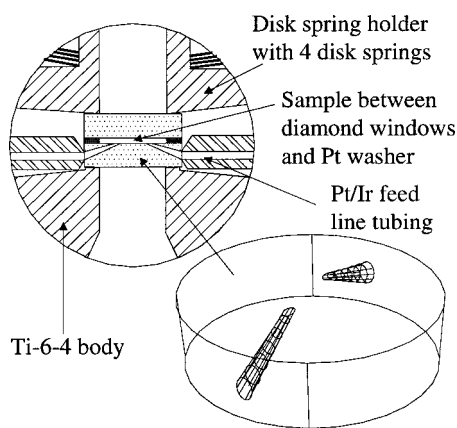

FIG. 1. Expanded cutaway view (not to scale) of the high-pressure IR flow-cell sample region including a three-dimensional close-up view of the specially prepared diamond window disk.

cell reflects our interest in studying aqueous solutions at high temperatures and pressures where the corrosivity is known to be severe, in particular, at extreme  $pH$  values.<sup>7,13</sup> For different chemical systems under high pressures and/or temperatures a variety of different materials could be selected.

In addition to the IR and photolysis studies shown herein, the cell may also be used for fluorescence, ultraviolet (UV) absorption, Raman, and x-ray absorption spectroscopic applications.

## II. DESCRIPTION OF THE OPTICAL HIGH-PRESSURE CELL

### A. Specially prepared diamond window disk

Diamond is not only a superb window material for high-pressure optical cells because of its well-known mechanical strength and chemical inertness but also because of its excellent optical properties. The transmission of a 1 mm thick diamond window has been reported from the far-infrared region at  $20\text{ cm}^{-1}$  up to the UV-visible region at  $500\text{ nm}$ .<sup>14</sup> Absorption bands were only found in the region from  $1900$  to  $2800\text{ cm}^{-1}$ , although the diamond still remains partially transparent here but with a minimum transmission of 20%. In all other areas of the entire spectral range the transmission has a value of 70% due to reflection losses at the surface. While significantly weaker, replacement of the diamond windows with sapphire would allow better investigation of the  $1900\text{--}2800\text{ cm}^{-1}$  region.

Figure 1 shows the specially prepared diamond window disk and how it is incorporated into the optical high-pressure cell design. The  $5\text{ mm diam} \times 1\text{ mm thick}$  chemical vapor deposition (CVD) diamond disks were supplied by Harris International. For a minimal additional cost, two holes are laser drilled through the body of one of the diamond disks. Each hole enters from a radial surface at the side of the disk and then the hole passes through the window at a  $68^\circ$  angle to exit through a flat face. Due to the drilling method, each hole is slightly coned so that the entrance hole at the side is  $125\text{ }\mu\text{m}$  in diameter and the exit hole is  $75\text{ }\mu\text{m}$  in diameter. The two holes serve as inlets and outlets for the fluid sample.

The chemical vapor deposition process that is used to manufacture diamond wafers inherently results in diamond

wafers that have an uneven distribution of mechanical strength throughout their body, i.e., one side is stronger than the other. The orientation of the window was selected so that the stronger side is the external surface, thereby maximizing the ultimate pressure limit of the IR cell. As depicted in Fig. 1, the sample is contained between two diamond disks (one without holes) and a cylindrical spacer or washer. The optical pathlength is determined by the thickness of this spacer. Hence, by replacing the spacer the optical pathlength can easily be altered and the lower limit of the pathlength is essentially limited by the thickness of the thinnest available foil. We fabricated spacers ranging in thickness from  $25\text{ }\mu\text{m}$  to  $5\text{ mm}$  with corresponding sample volumes of  $200\text{ nl}$  and  $40\text{ }\mu\text{l}$ , respectively. These extremely low cell volumes make the design ideal for kinetic studies using a flowing reactive solution. All spacers were manufactured using either electric discharge machining (EDM) for the thinnest foils or machined using a fixture in a lathe. The spacers require a polished finish ( $<10\text{ }\mu\text{m}$ ) to seal properly under pressure. Commercial foils typically fulfill this requirement and further polishing is unnecessary.

The  $1.6\text{ mm}$  outer diam (o.d.) Pt/Ir feed tubing seals directly to the diamond radial surface. In order to facilitate proper deformation of the tube for sealing purposes, the ends of the tubing are slightly coned and have a finish of at least  $32\text{ }\mu\text{m}$  (400 grit). The stacked diamond-spacer-diamond assembly is supported on one side by the rim of the aperture in the titanium alloy (Ti-6-4) body. The other side is held in a squeezer type assembly<sup>1</sup> using disk springs (Nimonic 90, Schnorr Corp.) and a retaining nut. The disk springs maintain the required sealing force and compensate for slight material expansion at high temperatures. The disk spring design ensures that the pathlength is not affected by changes in pressure or temperature. To prevent a failure in the diamond window, it is crucial that the diamond window disk is evenly supported on a perfectly flat surface that does not extend beyond the edge of the diamond window.

### B. Assembly of the optical high-pressure cell

Figure 2 shows an expanded view of the optical high-pressure cell. Except for the Pt/Ir tubing, the pathlength spacers, the spring disks, and the diamond windows, all parts are made from Ti-6-4 titanium alloy. The  $1.5\text{ in.} \times 2.2\text{ in.}$  body was stress relieved by heat treatment at  $650^\circ\text{C}$  prior to final machining. The body accepts four  $50\text{ W}$   $1/8\text{ in.}$  cartridge heaters and two independent platinum resistance probes for temperature measurements (not shown in Fig. 2). Both the body and the retaining nut have coned holes to provide a large clearance angle for the entering and exiting light. The stop ring prevents the retaining nut from being overtightened during assembly and establishes the correct compression force exerted onto the diamond-spacer-diamond assembly by the disk springs. The number of disk springs stacked onto the disk spring holder determines the pressure rating of the cell. We used four disk springs, setting the pressure rating to  $6000\text{ psi}$ . A centering shim aligns the diamond-spacer-

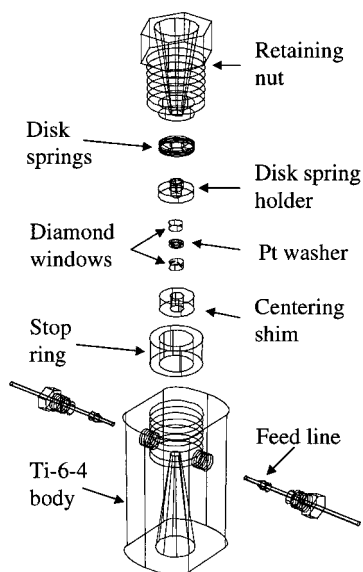

FIG. 2. Expanded schematic view of the high-pressure IR flow-cell assembly.

diamond assembly with the cell body. For each desired optical pathlength only a matched set of spacer and stop ring is required.

A milled channel in the centering shim and stop ring (not shown for clarity) provides clearance for the feed line tubing to the entrance holes of the diamond disk. The milled channel precisely aligns the inlet and outlet feed line tubing with their respective holes in the diamond disk. Also, a flat side surface is milled onto the end of the feed line tubing which prevents the tubing from rotating during assembly. The tip of the 1.6 mm o.d.  $\times$  0.38 mm i.d. Pt/Ir feed line tubing is sealed directly onto the diamond side surface using a compression seal. The tubing is “grasped” by swaging a standard 1.6 mm ferrule to the tube about 1 cm before the tube-to-diamond seal. In order to firmly grab the tube, a 0.13 mm deep groove for the ferrule is machined around the tubing surface and the pointed end of the ferrule is made slightly blunt. Alternatively, the ferrule may be welded or soldered onto the tubing if these components are made from other materials. Pressure tests confirmed that a torque of 0.678 Nm (0.5 ft/lb) applied to the 1.6 mm nut during assembly of the sample feed line is adequate for a 690 bar (10 000 psi) pressure. Strain on the attachment tubes must be avoided since flexing of the tubing breaks the tubing/diamond seal at the cell. Once connected, the tubing-to-diamond seal is very robust. The cell has gone through hundreds of evacuation (50 mTorr) and high-pressure cycles (5000 psi) without failure.

Before compressing the diamond–spacer–diamond assembly by tightening the large retaining nut, the assembly can be lightly held in place with a 1.6 mm pin, placed in the tubing hole. This prevents the diamond–spacer–diamond assembly from rotating during tightening of the large retaining nut. The seal between the tube tip and the diamond surface is maintained by a compressive force generated by the 1.6 mm nut (High Pressure Equipment Co.). At elevated temperatures, the differential expansion of the various cell components could potentially alter this initial sealing force. This

difficulty is mainly overcome by choosing materials with similar thermal expansion coefficients (e.g., Pt/Ir and Ti-6-4) and by establishing a small amount of compressive spring force between the tube tip and the ferrule that helps to maintain the seal. Alternatively, the tube sealing force could be precisely controlled by use of disk springs, similar to the pressure seal of the diamond–spacer–diamond assembly described here.

### C. External components

The cell is placed on a lightweight ceramic stand and thermally insulated with several layers of a glass fiber blanket. We have earlier described an efficient method to introduce samples into the cell.<sup>15</sup> Pressure is applied to the system using a standard syringe pump (ISCO model 100DX) and measured within  $\pm 1$  bar with a calibrated electronic pressure transducer (Precise Sensors, No. D451). A three-mode temperature controller (Omega, No. CN3000) controls the cell temperature to an accuracy of  $\pm 3$  °C. An additional redundant temperature limit controller (Watlow, series 94) is also used as a general safety measure.

The time-resolved IR spectra were acquired using a Kolmar Technologies mercury–cadmium–telluride (MCT) dual channel detector using a Bruker IFS66V instrument. The output from the detector was processed with a Bruker 200 MHz PAD82A digitizer (two channels, 8 bit, 20 MB). The time-resolved spectra were acquired from the ac-coupled detector channel while the proper phase correction was determined from the detector’s dc signal.

A supercritical fluid flow rate of 1.0 ml/min through the IR cell was accomplished by using two pumps (Varian 8500) in tandem. One pump, loaded with the homogeneous sample solution, was set at constant pressure while the other pump, set at constant flow, ran in reverse.

For photolysis, the fourth harmonic (266 nm) of a Nd:YAG laser, operating at 10 Hz and 10 mJ/pulse, was used.

## III. EXPERIMENTAL APPLICATIONS

### A. Infrared measurements of aqueous solutions to supercritical conditions of pressure and temperature

In Fig. 3 we show a temperature series of IR measurements of a deuterated 0.2 mol aqueous  $\text{Na}_2\text{WO}_4$  solution to 400 °C and 380 bar pressure. The spectra were obtained using an optical pathlength of 25  $\mu\text{m}$ . The  $\text{D}_2\text{O}$  background was independently measured under the same conditions and is already subtracted in the spectra shown in Fig. 3. The background subtraction also eliminated interference fringes from the short pathlengths that appeared as weak oscillations in the background. The subtraction of the water background was not quite complete in the case of the 400 °C spectrum, leaving behind the broad shallow feature near 960  $\text{cm}^{-1}$ . The pH value of the solution at room temperature was 8.5. At this pH value, the tungstate is present as a tetrahedrally coordinated  $\text{WO}_4^{2-}$  monomer. The frequency of the asymmetric stretching mode,  $\nu_3$ , at 828  $\text{cm}^{-1}$  does not change with temperature to within  $\pm 1$   $\text{cm}^{-1}$ . The loss in the intensity of the

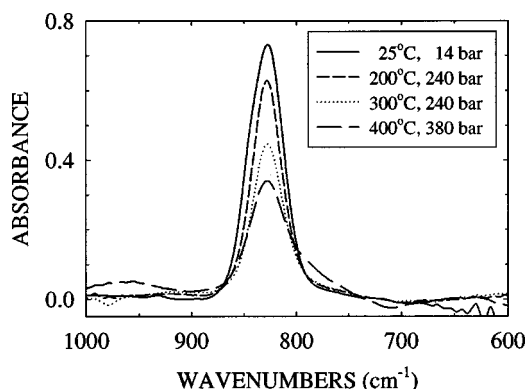

FIG. 3. Infrared spectra of a 0.2 mol aqueous  $\text{Na}_2\text{WO}_4$  solution (room temperature  $\text{pH}=8.5$ ) at several conditions of temperature and pressure, obtained with the high-pressure optical cell design with a 0.001 in. optical pathlength described here. The frequency of the asymmetric stretch remains constant within  $\pm 1 \text{ cm}^{-1}$ .

monomer band at high temperatures is primarily caused by a decrease in the solution density. These spectra confirm the observed constancy of the W–O bond length and increase of the Debye–Waller factor from recent x-ray absorption fine structure (XAFS) data.<sup>15</sup> There are no new vibrational modes emerging in the IR spectrum at high temperatures that would indicate the formation of isopolytungstates, known to form at lower  $\text{pH}$  values. This is in agreement with previous XAFS data.<sup>15</sup> Measurements of a series of acidified tungstate solutions to high temperatures were also performed with this cell and will be presented elsewhere.<sup>16</sup> The IR cell performed reliably during these measurements that required a large number of temperature and pressure cycles.

### B. Time-resolved infrared spectroscopy in supercritical fluids

The excellent transmission properties of diamond allow photochemical studies over a tremendous wavelength range. Figure 4 displays time-resolved IR (TRIR) spectra of a high-pressure UV laser photolysis reaction. The high energy UV laser beam was brought into the cell through the same win-

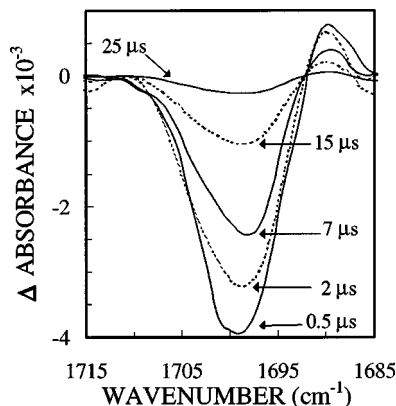

FIG. 4. TRIR spectra of photolysis of BNA with 266 nm light in supercritical  $\text{CO}_2$  (10% THF) at 40 °C, 5000 psi, and flow of 1.0 ml/min. The TRIR spectra show the change ( $\Delta$  absorbance) in the carbonyl bands of BNA and the intermediate photolysis complex as a function of time. To meet the sensitivity requirements for TRIR in ScF ( $10^{-3}$  abs) the cell pathlength was increased to 0.380 mm.

dows that were used for the time-resolved IR measurements but slightly off axis from the IR beam. Figure 4 shows TRIR spectra of  $\beta$ -naphthoyl azide (BNA) in supercritical  $\text{CO}_2$  (10% THF) at 40 °C and 5000 psi that has been photolysed with a 266 nm pulsed laser. These dynamic IR spectra show the change ( $\Delta$  absorbance) in the carbonyl bands of BNA and those of the intermediate photolysis complex as a function of time. The intermediate, at  $1689 \text{ cm}^{-1}$ , is formed immediately after the laser pulse and then disappears with time. The large negative deflection at  $1699 \text{ cm}^{-1}$  is due to the decrease in BNA immediately after the laser pulse and concurrent with the formation of the intermediate. At long times, this band returns to near zero since the photoproduct closely resembles BNA and their carbonyl bands are indistinguishable. Note that as the delay time increases both the negative and positive bands fall to zero. Additional TRIR data and a detailed discussion of BNA molecular photodynamics within supercritical  $\text{CO}_2$  will be presented in subsequent publications.

TRIR spectroscopy typically requires very high sensitivity (note that the maximum deflection in Fig. 4 is 4 milliabsorbance units). To improve sensitivity for TRIR measurements of BNA the pathlength of the cell was increased to 0.380 mm with the use of an appropriate platinum washer. Some IR birefringence could be observed when the cell's diamond windows were orthogonally aligned to the IR beam. Rotating the cell slightly off orthogonal eliminated this birefringence and made it easier to get the photolysis beam into the cell.

Laser photolysis and excitation in this cell are possible with high power lasers since diamonds can handle very high energy densities. We have made measurements at up to 50 mJ/pulse (10 Hz) with a  $Q$ -switched Nd:YAG laser (532 nm). No other window material is capable of handling these high pressures and high optical powers while transmitting light from the far IR through the UV.

### ACKNOWLEDGMENTS

Work by one of the authors (M.M.H.) was supported by the U.S. Department of Energy, Office of Environmental Management, under Contract No. DE-AC06-76RLO 1830. Work by a second author (J.L.F.) was supported by the Director, Office of Energy Research, Office of Basic Energy Sciences, Chemical Sciences Division of the U.S. Department of Energy, under Contract No. DE-AC06-76RLO 1830. We acknowledge Tom Autrey for providing the BNA compound and discussions of the photochemistry.

<sup>1</sup>W. F. Sherman and A. A. Stadtmuller, *Experimental Techniques in High-Pressure Research* (Wiley, New York, 1987).

<sup>2</sup>Yu. E. Gorbaty, *Rev. Sci. Instrum.* **65**, 505 (1994).

<sup>3</sup>J. P. Blitz, J. L. Fulton, and R. D. Smith, *Appl. Spectrosc.* **43**, 812 (1989).

<sup>4</sup>J. W. Schoppelrei, M. L. Kieke, X. Wang, M. T. Klein, and T. B. Brill, *J. Phys. Chem.* **100**, 14343 (1996).

<sup>5</sup>Y. Ikushima, K. Hatakeda, O. Sato, T. Yokoyama, and M. Arai, *Angew. Chem. Int. Ed. Engl.* **38**, 2910 (1999).

<sup>6</sup>J. L. Fulton, D. M. Pfund, and Y. Ma, *Rev. Sci. Instrum.* **67**, 1 (1996).

- <sup>7</sup>E. U. Frank and K. Roth, *Discuss. Faraday Soc.* **43**, 108 (1967).
- <sup>8</sup>J. L. Fulton, G. G. Yee, and R. D. Smith, *J. Am. Chem. Soc.* **113**, 8327 (1991).
- <sup>9</sup>M. Poliakoff, S. M. Howdle, and S. G. Kazarian, *Angew. Chem. Int. Ed. Engl.* **34**, 1275 (1995).
- <sup>10</sup>S. L. Wallen, D. M. Pfund, J. L. Fulton, and C. R. Yonker, *Rev. Sci. Instrum.* **67**, 1 (1996).
- <sup>11</sup>C. E. Manning, *Geochim. Cosmochim. Acta* **58**, 4831 (1994).
- <sup>12</sup>K. Ishihara and M. Takagi, *Rev. Sci. Instrum.* **65**, 513 (1994).
- <sup>13</sup>K. W. Downey, R. H. Snow, D. A. Hazlebeck, and A. J. Roberts, in *Innovations in Supercritical Fluids*, ACS Symposium Series No. 608, edited by K. W. Hutchenson and N. R. Foster (American Chemical Society, Washington, DC, 1995), pp. 313–326.
- <sup>14</sup>R. S. Sussmann *et al.*, *Il Nuovo Cimento* **20**, 503 (1998).
- <sup>15</sup>M. M. Hoffmann, J. G. Darab, S. M. Heald, C. R. Yonker, and J. L. Fulton, *Chem. Geol.* (in press).
- <sup>16</sup>M. M. Hoffmann, J. G. Darab, and J. L. Fulton, in *Proceedings of the 13th International Conference on the Properties of Water and Steam*, edited by P. R. Tremaine, P. G. Hill, D. E. Irish, and P. U. Balakrishman (NRC Press, Ottawa, 2000).