

Evaluation of different methods in quantification of manufacturing defects

Bui Minh Hien.

University of Savoie, SYMME Laboratory, 5 chemin de Bellevue, 74944 Annecy le Vieux, France

Sergent A.

University of Savoie, SYMME Laboratory, 5 chemin de Bellevue, 74944 Annecy le Vieux, France

Villeneuve F.

*Grenoble-INP / UJF-Grenoble 1 / CNRS, G-SCOP UMR5272 (1) : G-SCOP, University of Grenoble
46 Avenue Félix Viallet - Grenoble, F-38031, France*

Abstract

In the context of manufacturing defects, our interest is the calculation methodologies that are used to quantify these defects. The manufacturing defects can be divided into two categories: machining defects and positioning defects. A double measurement method is principally used to quantify separately machining and positioning defect. The first measurement is operated inside a machine tool just after the final cutting step. The second measurement is realised outside of the machine tool (e.g. on a coordinate measuring machine - CMM). However, data processing method and precision between two different machines are different. Consequently, the measurement results obtained from these machines may be not comparable to quantify precisely the manufacturing defects. Several solutions are proposed and analysed in this paper to estimate comparable capability of the measurement results obtained by the two different measurement means.

Keywords : *machining defect, positioning defects, evaluation, calculation methodology, Small Displacement Torsor (SDT).*

1. Introduction

In recent years, many research works have been conducted on the factors that affect the quality of product in the mechanical manufacture. The quality of a machined part is estimated based on its defects during manufacturing process, it is called manufacturing defects. These defects are considered under different point of views. Usually, in classical manufacturing processes, the manufacturing defects can be divided into two categories: machining and positioning defects. In consideration of machining defects, Larue et al. [1] observed defects of cutting tool during flank milling, and calibration method are

then used to minimize uncertainties of manufacturing. Besides, cutting parameters are also investigated as factors affecting the product quality. Several experimental results are available. Sun et al. [2] presented strategies and algorithm on how to select width of cut, feed rate and spindle speed. Beauchamp et al. [3] investigated effects of six independent variables (cutting speed, feed rate, depth of cut, tool nose radius, tool length and type of boring bar) on surface roughness in a lathe dry boring operation. In addition, Ramesh et al. [4] focused on effects of different factors occurred during machining processes, for instance, geometric, thermal errors of machine elements and cutting-

force errors. They considered geometric, kinematic errors of machine elements as a basic inaccuracy; changing the temperature of various machine elements are causes of increasing inaccuracy of machine tools; work-piece displacements on a fixture are also taken into account and could be reduced using tool-path compensation. In the research of positioning defects, different areas have been investigated. Locating performance has been studied by many researchers. Asada et al. [5] presented a model of the fixture-workpiece in 3D using the Jacobian matrix. This model was then used to analyze deterministic positioning using kinetic analysis. Song et al. [6] established an analytical criterion for evaluation of deterministic locating using a locating matrix that is based on translations and rotations of 6 locating points. Li et al. [7] presented a model that allows reducing workpiece-locating errors due to rigid body displacements. The optimization workpiece location was achieved using placement of locators and clamps around the workpiece based on elastic deformation of the workpiece at the fixturing points. Surface error at the contact region is also a factor that affects on the workpiece position. Salisbury et al. [8] presented a model to predict workpiece location and orientation due to locating planes that contain surface errors. This model is just valid for 3-2-1 fixturing method. Additionally, Sangnui et al. [9] created a mathematical model in order to estimate the impact of surface errors on the positions of a cylindrical workpiece. Most of the mentioned researches focus on errors of machines, cutting tools and fixtures. Little research on calculation methodology are carried as well as evaluation of methods that are used to quantify manufacturing defects. Concerning a method for quantification of machining and positioning defects, Tichadou et al. [10] proposed a double measurement method. The principal concept of this method is based on two distinct measurements: the first one inside a machine tool just after the final cutting step and the other one outside of the machine tool (e.g. on a coordinate measuring machine - CMM). This method allows quantifying separately machining and positioning defects. However, some problems can be seen from this method as follows.

- Data processing method and precision between the two measurement means may be different. Consequently, measurement results obtained from these machines are not comparable to quantify precisely the manufacturing defects.

This problem will be detailed in next section.

- Some machine tools are just equipped with measurement tools (touch probe) but have not metrology software. Thus, the measurement results obtained from these machines are just coordinates of measured points.

In order to solve outstanding problems, several solutions are proposed in this paper to estimate comparable capability of the results, which are obtained by the two different measurement means.

- Using the same method to associate a surface from a cloud of measured points. For instance, the least-square best-fit method [11] is used to rebuild the geometric elements from measured data that are obtained from the two different machines. The advantage of this solution is to suppress deviations of the data processing.
- Two geometric elements of machined parts are chosen and measured by the two measurement means. The measured points are then analysed using the least-square best-fit mentioned earlier. The measurement results are finally compared in order to evaluate whether differences between the two measurement means are significant/insignificant.

For that purposes, the following experimental application is used for illustrating of our proposed solutions. This article is organized in five sections. The first section is introduction. The second section reminds several methods, for instance, the Small Displacement Torsors concept that is used to determine the manufacturing defects; a double method used to quantify separately machining and positioning defects and a method that is used for reconstruction of geometric elements from three-dimensional measuring points. The third section covers the different processes that are executed on the machine tool and the measuring coordinate machine. In the fourth section, relationships of two machined planes are obtained by the two measurement means. These results are then analysed to evaluate the comparable capability of the two measurement means. Our conclusions are then presented in the last section.

2. Methods

2.1 The Small Displacement Torsor concept

The methods used for determining the manufacturing defects are based on the Small Displacement Torsor (SDT) concept, which has been developed since the seventies by Bourdet et al. [12, 13]. This concept is based on an assumption of small displacements of a rigid body. It allows solving a general problem of the fit of a geometrical surface model to a set of points. A SDT is represented using two vectors: vector \mathbf{R} includes three small rotations (r_x, r_y, r_z) and vector \mathbf{T} includes three small translations (t_x, t_y, t_z). Thank to the SDT concept, Villeneuve et al. [14] have extended the concept to manufacturing process where machining defects were obtained using measurement of relationships between a nominal part (perfect surfaces) and a real part. A SDT can be used to express the defects of different surfaces. For instance: two rotations and one translation (along a normal vector of a plane) are used to express a SDT of a plane. Two rotations and two translations (along two axes, which are perpendicular with a cylinder axis) are used for a cylinder SDT, etc. (Figure 1.) illustrates a plane SDT used to represent the small defects between a real plane and its nominal plane. Let (OXYZ) be the origin system of a plane, which has a normal vector along Z. A SDT of this plane is expressed using three components, which are differences between an associated plane to the real one and a nominal plane. The plane SDT is shown as equation (1).

$$\mathcal{J}_P = \{\overline{\mathbf{R}} \quad \overline{\mathbf{T}}\}_O = \begin{Bmatrix} r_x & 0 \\ r_y & 0 \\ 0 & t_z \end{Bmatrix}_{OXYZ} \quad (1)$$

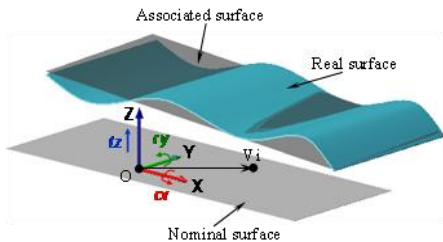

Figure 1 : A plane SDT [15]

The SDT concept is used in this study to describe the geometrical errors of the machined part surfaces.

2.2 Reconstruction of geometrical elements from 3D measuring points

Measurement equipments of a machine tool or a measuring machine are used to measure surfaces of a machined part (e.g. machined planes, part cylinder). Measured data are then used for reconstructing the measured surfaces; it is called associated surfaces that are finally used to determine the SDT components. In the recent study, the least-squares best-fit method is used to reconstruct geometric elements from 3D measuring points. Thank to this method, a plane is specified by a centroid on the plane and a direction cosines of the normal to the plane; a cylinder is specified by a point on its axis, a vector pointing along the axis and its radius.

2.3 A double measurement

As mentioned earlier, the manufacturing defects are divided into two categories: machining and positioning defects. A measuring method that is presented by Tichadou [10] allows quantifying separately these defects. This method is illustrated by a batch of turning parts (in one-dimension) (figure 2.). Each part has two machined surfaces (1 and 2) and a locating surface (0). They considered that the variations of the surface positions are independent. Thus, equation (2) is obtained.

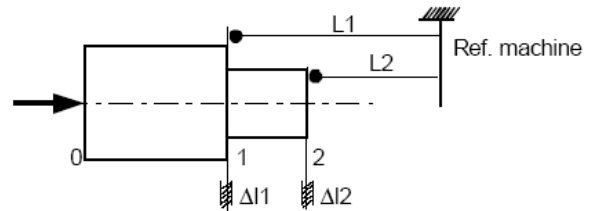

Figure 2 : Probing on a machine tool [10]

$$s_{12}^2 = s_1^2 + s_2^2 \quad (2)$$

where

- s_{12}^2 variance of the distances between the two machined surfaces
- s_1^2, s_2^2 variances of the machined surfaces 1 and 2, respectively.

Using the measurement on the CNC machine, they quantified machining defects of machined surfaces. To quantify positioning defects, they proposed a complementary measurement on a CMM (Figure 3 :

In this measurement, they obtained s_{01}^2 and s_{02}^2 that are variances of the distances between the locating surface and the two machined surfaces.

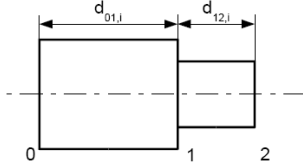

Figure 3 : Measure a part on a CMM [10]

The following equations are established based on the assumptions that the variations of the surface positions are independent.

$$\begin{cases} s_{01}^2 = s_0^2 + s_1^2 \\ s_{02}^2 = s_0^2 + s_2^2 \end{cases} \quad (3)$$

Using the results obtained from the two measurements (s_1^2, s_2^2 obtained from the CMM; s_{01}^2, s_{02}^2 obtained from the CNC machine), they quantified variances of the locating surfaces.

$$\begin{cases} s_0^2 = s_{01}^2 - s_1^2 \\ s_0^2 = s_{02}^2 - s_2^2 \end{cases} \quad (4)$$

The problem that can be seen throughout the above example is the following. If the data processing of the metrology software and the precision between the two measurement means are different then the measurement results cannot be used to quantify the positioning defects. To solve this problem, we therefore propose:

- Using the same data processing method to treat the measured point obtained from the two measurement means,
- Comparing the relation between the two machined surfaces to prove that the measurement results obtained from the two measurement means are comparable.

These are the main objectives of this paper. In addition, our investigation will consider the manufacturing defects in three-dimension. The machined parts and the manufacturing processes are described in next section.

3. Experimental application

50 workpieces were produced on a CNC milling machine (DMG-DEKEL MAHO DMU50) as a statistical sample. Each workpiece is carried out for fixturing and machining on only one set-up. Two different plane surfaces are machined and notated as (Figure 4.)

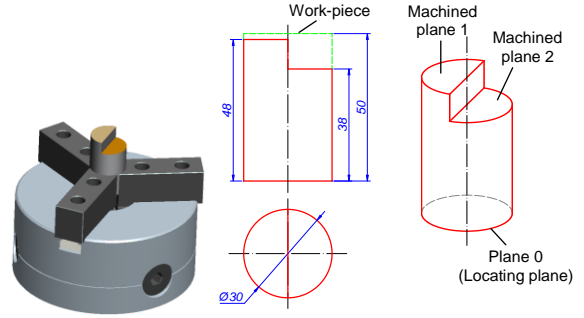

Figure 4 : Machined plane surfaces

Two planes of the part are machined by an end mill ($\phi 20\text{mm}$) with two different tool paths. A Circle path is used for machining plane 1, and only one pass of the end mill is used on this plane. A straight line path is used for machining plane 2 with five passes (Figure 5.)

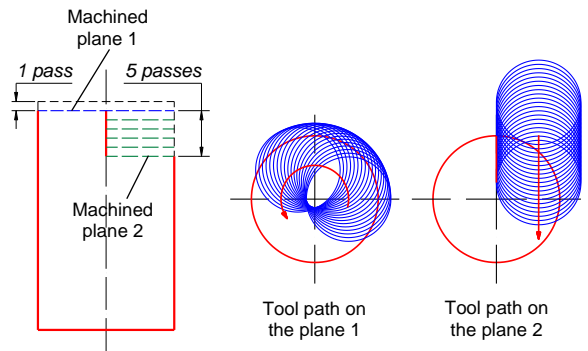

Figure 5 : Tool path of the two machined planes

3.1 Measurements inside the machine tool

The workpieces are fixed and machined on the CNC machine. The machined parts are then measured inside the machined tool at the end machining operation (without disassembly). The objective of these measurements is to determine the position of each machined surface related to reference of the machine tool, namely the machine coordinate system (MCS). Variance of 50 parts are then

calculated to obtain the machining defects. For a machined plane, ten measuring points (Figure 6 :) are used for measurement. The measured surfaces are then reconstructed by the least-square best-fit to evaluate their deviations. Nevertheless, a common reference for the two measurement means (CNC machine and CMM) has to be created for comparison of the measurement results obtained from these measurement means as well as for quantification of positioning defects. A common reference can be created from the part cylinder axis which does not change on the different machines. This common reference is called as part coordinate system (PCS).

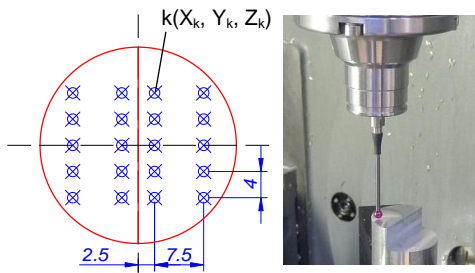

Figure 6 : Measuring points on a machined plane

Machining defects of the machined planes can be expressed in the MCS or in the PCS. For instance, these defects are expressed in the PCS (5).

$$\begin{aligned}
 \mathcal{J}_{P1} &= \begin{Bmatrix} r_{X1} & 0 \\ r_{Y1} & 0 \\ 0 & t_{Z1} \end{Bmatrix}_{(O_PXYZ)} ; \mathcal{J}_{P2} \\
 &= \begin{Bmatrix} r_{X2} & 0 \\ r_{Y2} & 0 \\ 0 & t_{Z2} \end{Bmatrix}_{(O_PXYZ)} \quad (5)
 \end{aligned}$$

where

$r_{X1}, r_{X2}; r_{Y1}, r_{Y2}$ are rotation deviations of the machined planes around X and Y-axis of the PCS, respectively.

t_{Z1}, t_{Z2} are translation deviations of the machined planes along Z-axis of the PCS.

3.2 Measurements on the CMM

After machining and measuring of the part on the CNC machine, the machined parts are then fixed on the CMM by a different fixture to be able to measure every surfaces of the machined part which

has been used for positioning or which has been machined on the CNC machine. The PCS is not only used to compare the measurement results obtained from the two machines (CNC and CMM) but also used to analyse the defects of the machined surfaces for verification of the obtained results. The double measurement can be illustrated as (figure 7.)

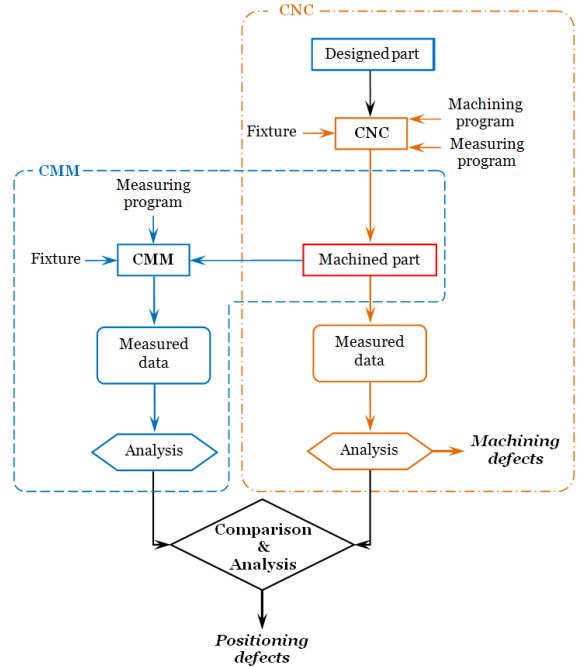

Figure 7 : The double measurement

To ensure that the noises in a measurement system (or measurement noise) do not influence on the obtained results, measurement noise tests are carried out on both machines as below. On the CNC machine, a square gage block (class 0) was measured for 100 times repeatedly [16] to estimate the dispersion of measurement. The results show that the standard deviation of a measured length on this machine is about: $0.27 \times 10^{-3}mm$. This is insignificant compared with the standard deviations of the machining defects obtained in this study ($1.92 \times 10^{-3}mm$ or $1.77 \times 10^{-3}mm$). On the CMM (Mahr-Vision MS222), a series of 50 measurements is executed to measure a part that is chosen randomly from the batch of 50 machined parts. The same measurement process is used for this noise test and for measuring the 50 machined parts. Results show that standard deviation of a distance between two machined surfaces is about $0.29 \times 10^{-3}mm$. This is also insignificant compared to

the standard deviation of the distances between the workpiece's locating plane and the machined plane ($20 \times 10^{-3} mm$). Consequently, the measurement noise of these two machines is negligible in the following measurement results. In addition, Ramesh et al. [17] said that continuous usage of a machine tool causes heat generation at the moving elements and this heat causes expansion of the various structural elements of the machined tool. To reduce variation of the heat between the moving elements in the machines, a warm-up program is run before the machining and measuring processes.

3.3 Coordinate systems

Generally, measured points obtained from a measurement mean are expressed in the machine coordinate system (MCS). The MCS is used for analysing of the machining defects on the CNC machine. Whereas, the PCS is used to compare the measurement results obtained from the two measurement means as well as to quantify the positioning defects.

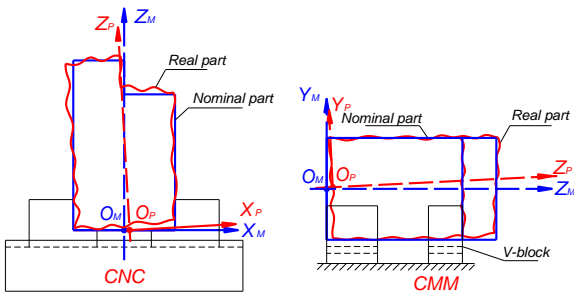

Figure 8 : The coordinate systems

The PCS is considered as a common reference for the two measurement means because it is created from a part's cylinder axis which doesn't change. However, the PCS created on the CNC machine and the CMM are different (figure 8.) It is explained clearly as follows.

3.3.1 A PCS on the CNC machine

- Locating plane of a part cannot be measured on the CNC machine. Thus, to define origin of a PCS, the machine plane O_MXY need to be used here. This plane is defined by the two following steps (without workpiece on the fixture): 1 - Measure locating plane of the fixture; 2 - Set a zero offset for Z axis of the machine on this

plane. In other word, the fixture locating plane is considered as the machine plane O_MXY which is a perfect plane.

- A part cylinder is measured to define the Z axis of the PCS.
- Intersection point between Z axis and the plane O_MXY defines an origin of the PCS on the CNC machine.
- X and Y axes of the PCS are defined by two axes which pass through the above point intersection and are parallel to X and Y axes of the machine, perpendicular with Z axis of the PCS.

3.3.2 A PCS on the CMM

- A machined part cylinder is measured to define the Z axis of the PCS.
- Locating plane of the machined part is measured to define a plane OXY .
- Intersection point between Z axis and the plane OXY defines an origin of the PCS.
- X and Y axes of the PCS are defined by two axes which pass through the above point intersection and are parallel to X and Y axes of the machine, perpendicular with Z axis of the PCS.

As mentioned earlier, the objective of this paper is to evaluate the comparable capability of the measurement results obtained from the two measurement means. Hence, the PCS is used to determine defects between the two machined planes (1 and 2). These results are then compared and estimated.

4. Results

4.1 Rotation components of SDTs

Rotation defect of a machined plane is defined as an angle between a normal vector of the machined plane and the part's cylinder axis. It is illustrated as (Figure 9.)

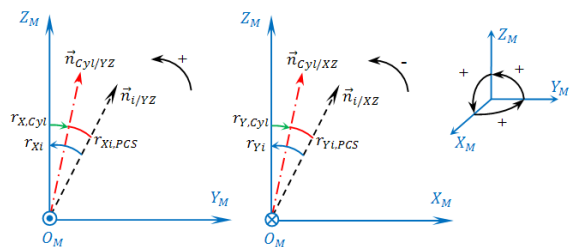

Figure 9 : Rotation defects

Thus, rotation deviations of machined planes are determined by equations (6).

$$\begin{cases} r_{Xi,PCS} = \arctan\left(\frac{n_{Yi}}{n_{Zi}}\right) - \arctan\left(\frac{n_{Yi}}{n_{Zi}}\right) \\ r_{Yi,PCS} = \arctan\left(\frac{n_{Xi}}{n_{Zi}}\right) - \arctan\left(\frac{n_{Xi}}{n_{Zi}}\right) \end{cases} \quad (6)$$

where

- $r_{Xi,PCS}, r_{Yi,PCS}$ are rotations of machined plane i in the PCS.
- $\vec{n}_{Cyl}(n_{X,Cyl}, n_{Y,Cyl}, n_{Z,Cyl})$ is direction vector of the part's cylinder axis.

The variance of the rotation defects obtained are shown in Tabel 1.

Table 1 : Rotation defects of the machined planes

Components	CNC	CMM	Test for equality of variances
$s_{r_{X1}}^2$ (rad ²)	3.057E-07	2.558E-07	$\Delta = 0.498E-07$ <i>Test OK</i>
$s_{r_{Y1}}^2$ (rad ²)	2.067E-07	2.317E-07	$\Delta = 0.25E-07$ <i>Test OK</i>
$s_{r_{X2}}^2$ (rad ²)	3.101E-07	2.407E-07	$\Delta = 0.693E-07$ <i>Test OK</i>
$s_{r_{Y2}}^2$ (rad ²)	2.469E-07	2.379E-07	$\Delta = 0.095E-07$ <i>Test OK</i>

For each component, a test for equality of variances is used to affirm whether differences between the variances obtained from the two machines are significant or insignificant. The last column in Table 1. shows that the differences between rotation components of the machined planes 1 and 2 obtained by the two measurements are insignificant. Comparisons of translation components of the machined planes will be considered in section below.

4.2 Translation component of SDTs

On the designed part, the two machined planes are parallel. In practice, because of manufacturing defects these two machined planes may be not parallel. Thus, in order to evaluate a translation relationship between these two planes, the two different following methods are proposed. As it is mentioned, one of the objectives of this paper is to

evaluate relationships between the two machined planes obtained from the two different measurement means. Nevertheless, to verify the results obtained from the proposed methods, translation defects of the machined planes need also to be obtained. In general, different calculation methods give different results, namely uncertainty of calculation method. In case of the differences between the proposed methods are insignificant, these methods are accepted. Hereafter, two methods are proposed in order to consider the translation relationships of two planes in the PCS. The results obtained from these methods are then assessed to allow us choosing a suitable method.

4.2.1 Methods

Let t_{12CNC} and t_{12CMM} be translation relationships between the two machined planes that are obtained on the CNC machine and the CMM, respectively.

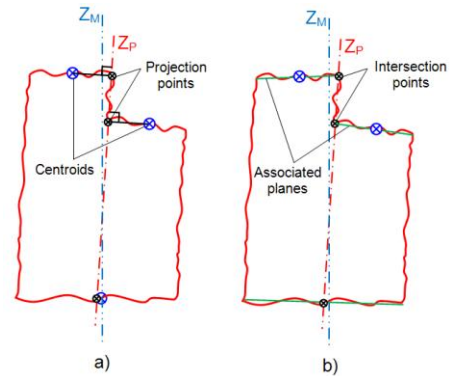

Figure 10 : Two proposed methods

a) Projection of plane centroids on the Z-axis of the PCS (Projection Z_p method)

In this method, centroid of each associated plane is projected on the Z-axis of the PCS (Figure 10 : a). It means that a translation relationship between two planes is expressed by a distance of two projection points of the centroids of the associated planes on the Z-axis of the PCS. Variance of all 50 translations relationships is finally calculated.

b) Intersection of associated planes and the Z-axis of the PCS (Intersection Z_p method)

A translation relationship of two planes is here expressed by a distance between two intersection points that are intersections of associated planes and the Z-axis of the PCS (Figure 10 : b).

4.2.2 Interpreting results

Hereafter, results of the two different methods will be shown and analyzed. To assess the results obtained from a method, the difference (Δ) between $s_{t_{12}}^2$ determined from the two measurement means is firstly compared. Bartlett's test is then used to test if two samples (t_{12CNC}, t_{12CMM}) have equal variances.

a) Projection Z_P method

In this method, the difference (Δ) between $s_{t_{12}}^2$ obtained from the two machines is insignificant compared with $s_{t_{12CNC}}^2$ and $s_{t_{12CMM}}^2$ Table 2. and the test for equality of variances is significant.

Table 2 : The projection Z_P method

Components	$s_{t_{12}}^2$ (mm ²)
CNC	3.450E-05
CMM	4.409E-05
Δ	0.959E-05
Test for equality of variances	Test OK

To verify the results of this method, an analysis of relations of the variables obtained from the measurement on the CNC machine is carried out as follows. According to properties of variance and covariance in probability theory and statistics, two random variables x and y can be expressed in equation (7).

$$s_{(x-y)}^2 = s_x^2 + s_y^2 - 2Cov(x, y) \quad (7)$$

where

- $s_{(x-y)}^2$ is variance of sum the two random variables x and y.
- s_x^2, s_y^2 are variances of x and y, respectively.
- $Cov(x, y)$ is covariance of x and y.

Equation (7) is used to verify the measurement results obtained from the CNC machine. Let t_{01CNC}, t_{02CNC} be translation deviations between the machined planes 1, 2 and the workpiece's locating plane. As mentioned in section 3.3.1, the workpiece's locating plane contact (plane 0) in t_{01CNC}, t_{02CNC} is considered as a perfect plane so that they are translation deviations of the machined

planes 1 and 2. These deviations can be rewritten as t_{1CNC}, t_{2CNC} . Let $s_{t_{12CNC}}^2$ be variance of sum the two variables t_{1CNC}, t_{2CNC} .

Thus, the results obtained in this method are expressed as equation (8).

$$s_{t_{12CNC}}^2 = s_{t_{1CNC}}^2 + s_{t_{2CNC}}^2 - 2Cov(t_{1CNC}, t_{2CNC}) \quad (8)$$

Table 3 : Results of the projection Z_P method

Components	$s_{t_1}^2$ (mm ²)	$s_{t_2}^2$ (mm ²)	$s_{t_{12}}^2$ (mm ²)
CNC	1.338E-05	1.049E-05	3.450E-05
$Cov(t_{1CNC}, t_{2CNC})$	-5.21E-06		

The results in Table 3 show that they satisfy (9) the relations defined by equation (8) as summarized in equation (9).

$$\begin{cases} s_{t_{12CNC}}^2 = 3.45 \times 10^{-5} \\ s_{t_{1CNC}}^2 + s_{t_{2CNC}}^2 - Cov(t_{1CNC}, t_{2CNC}) = 3. \end{cases} \quad (9)$$

The fifty values of t_{01CNC} and t_{02CNC} are plotted in (figure 10.) in order to, one more time, verify these results.

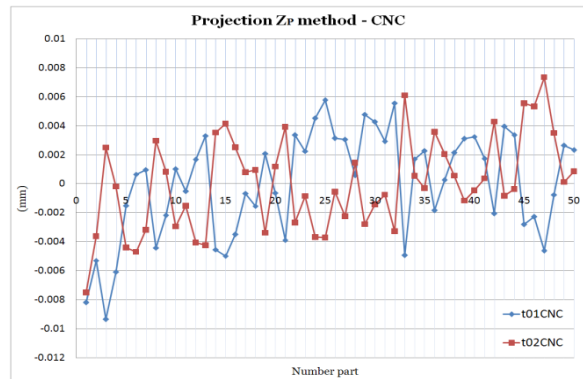

Figure 11 : The projection Z_P method

It can be seen that the scatter plots of t_{01CNC} and t_{02CNC} seem to two symmetric graphics. It means that when translation defects of the machined plane 1 increase the translation defects of the machined plane 2 decrease and vice versa. To explain this phenomenon, an assumption is proposed that the machining defects are insignificant compared with positioning defects of the workpiece cylinders. Thus, centroids of the machined planes do not change. Changing of the workpiece cylinders have, therefore, to be taken into account as in (Figure.12). k, l, m, n in this figure are cylinder axes of machined parts which are considered having different rotation defects.

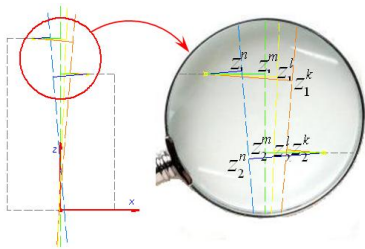

Figure 12 : Changing of the workpieces' cylinder axes

Four rotations of the workpieces' cylinder axes are taken from measurements of the workpieces on the fixture, and the results are shown in Table 4.

Table 4 : Four examples

Components	k	l	m	n
t_{01} (mm)	47.27	47.67	48	48.53
t_{02} (mm)	38.48	38.27	38	37.26

The results show that the values of the distances t_{01} and t_{02} are symmetric. Hence, changes of the workpieces' cylinder axes are cause of the symmetric phenomenon in the projection Z_p method. According to the above analysis, the results obtained from the projection Z_p method can be used for comparison of the measurements results obtained from the two measurement means, but it cannot be used for quantification of positioning defects.

b) Intersection Z_p method

Table 5. shows that the difference (Δ) between $s_{t_{12}}^2$ obtained from the two machines is insignificant. In other word, the test for equality of variances is significant.

Table 5 : The intersection Z_p method

Components	$s_{t_{12}}^2$ (mm ²)
CNC	7.720E-07
CMM	7.864E-07
Δ	0.144E-07
Test for equality of variances	Test OK

Consequently, the results obtained from this method need to be verified with the relations defined by equation (8).

Table 6 : Results of the intersection Z_p method

Components	$s_{t_1}^2$ (mm ²)	$s_{t_2}^2$ (mm ²)	$v_{t_{12}}^2$ (mm ²)
CNC	40.56E-07	49.59E-07	7.72E-07
$Cov(t_{1CNC}, t_{2CNC})$	40.39E-07		

Difference between $s_{t_{12CNC}}^2$ obtained from the measurements and calculation of the relations (8) is significant (10). Hence, the fifty values of t_{01CNC} and t_{02CNC} are plotted in Fig.13 in order to find out the causes of this error.

$$\left\{ \begin{array}{l} s_{t_{12CNC}}^2 = 7.72 \times 10^{-7} \\ s_{t_{1CNC}}^2 + s_{t_{2CNC}}^2 - 2Cov(t_{1CNC}, t_{2CNC}) = ' \end{array} \right. \quad (10)$$

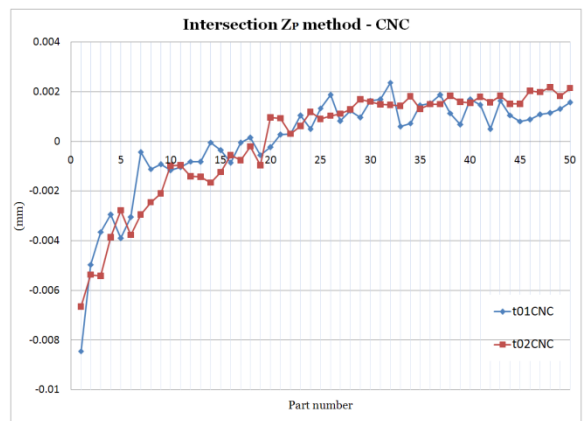

Figure 13 : The intersection Z_p method

The results in (Figure:13) show that the translation variations of the two machined planes increase together during machining times (from the 1st part to the 50th part). In metrology, measurement errors can be subdivided in two classes, namely in random

errors and systematic errors. The division of measurement errors into systematic and random is important, because these components are manifested differently and different approaches are required to estimate them [18]. The drifts that occurred in translation defects of the machined planes (Figure. 13) can be considered as systematic errors. Sources of these systematic errors may be changing of the machining, measuring environment, e.g. thermal error, which interferes with the machining measuring process. Ramesh et al. [17] investigated a temperature variation at critical elements on machine tools, which is a major source of inaccuracy. The systematic error is proposed to be corrected. The results obtained after the correction will be re-verified by the relations (8). For that purpose, regression analysis is used for modelling, analysing the drifts of translation defects. There are two types of regression analysis, linear regression where the data are approximated using a straight line and vice-versa is non-linear regression. From (Figure: 13), the drifts of the two machined planes can be seen that are non-linear. Thus, non-linear regression is applied in this case. There are different functions of non-linear regression, e.g. power, polynomial, and logarithmic ... According to scatter plots of the variables, two functions, polynomial and logarithmic regression, are selected for describing of fitting functions. A correlation coefficient R^2 is then used to estimate deviations between the variables and the fitting functions. The final fitting function is selected based on comparisons of R^2 .

Table 7 : Fitting functions

Component	Logarithmic regression		Polynomial regression	
	Fitting function	R^2	Fitting function	R^2
s				
t_z				
Machined planes 1	$0.002 \ln(n)$	0.9	$-5 \times 10^{-6}n^2 + 0.005$	0.8
	-0.007	6		3
Machined planes 2	$0.002 \ln(n)$	0.8	$-5 \times 10^{-6}n^2 + 0.005$	0.9
	-0.006	8		5

n is number of machined part in the fitting function Table 7. The fitting function of logarithmic regression being selected for the correction of systematic errors, the results after the corrections show as Table 8.

Table 8 : Results after correction of systematic errors

Components	$s_{t_1}^2$ (mm ²)	$s_{t_2}^2$ (mm ²)	$s_{t_{12}}^2$ (mm ²)
CNC	5.10E-07	3.66E-07	7.72E-07
$Cov(t_{1CNC}, t_{2CNC})$	0.51E-07		

Results in Table.8 are used for re-verification of the relations (8).

$$\begin{cases} s_{t_{12CNC}}^2 = 7.72 \times 10^{-7} \\ s_{t_{1CNC}}^2 + s_{t_{2CNC}}^2 - 2Cov(t_{1CNC}, t_{2CNC}) = \end{cases} \quad (11)$$

Difference between two results obtained in (11) is insignificant. Consequently, the relations of three variables t_{1CNC}, t_{2CNC} and t_{12CNC} are verified as equation (8). From comparison of rotations and translation (in the intersection Z_p method) of the two machined planes, we can conclude that the measurement results obtained from the two different measurement means are comparable. In addition, the intersection Z_p method will can be used for quantification of translation components of the positioning defects.

5. Conclusions

The paper are represented the double measurement method that allows quantifying separately the machining and positioning defects. Several solutions are proposed to complete the analysis in this method. These are shown as follows.

- Using the same method to associate a surface from a cloud of measured points, the least-square best-fit, obtained from the two different measurement means. This allows suppressing deviations of the different data treatment method
- Proposing the two different methods to determine the translation relation between two machined surface planes that may be not parallel because of machining imperfections

- Comparing the relations (translation and rotations) of two machined surface planes obtained from the two different measurement means to prove that the results are comparable

As examination of experimental results, the results obtained from the different proposed methods are significantly different. Consequently, analysis and selection of an appropriate method for quantification of manufacturing defects is necessary. A selected method is not only used to evaluate the comparable capability of the measurement results obtained from the two different measurement means but also used to quantify the positioning defects. Moreover, the results show that the correction of systematic errors in measurement results is needed.

References

- [1] Larue A., Anselmetti B., 2003, Deviation of a machined surface in flank milling, *International Journal of Machine tool and Manufacture*, 43: 129-138.
- [2] Sun G., Wright P., 2005, Simulation-based cutting parameter selection for ball end milling, *Journal of Manufacturing of Systems*, 24(4): 352-365.
- [3] Beauchamp, Y., Thomas, M., Youssef, Y.A., Masounave, J., 2000, Investigation of cutting parameter effects on surface roughness in lathe boring operation by use of a full factorial design, *Computers & Industrial Engineering*, 31: 645-651.
- [4] Ramesh R., Manan M. A., Poo A. N., 2000, Error compensation in machine tool – a review. Part II: thermal errors, *International Journal of Machine tool and Manufacture*, 40: 1257-1284.
- [5] Asada H., By A., 1985, Kinematic analysis of workpart fixturing for flexible assembly with automatically reconfigurable fixtures, *IEEE Journal of Robotic and Automation*, 1:86-94.
- [6] Song H., Rong Y., 2005, Locating completeness evaluation and revision in fixture Plan, *Journal Robotics and Computer-Integrated Manufacturing*, 21:368-378.
- [7] Li B., Melkote S.N., 1999, Improved workpiece location accuracy through fixture layout optimization, *International Journal of Machine Tool and Manufacture*, 39:871-883.
- [8] Salisbury, E.J., Peters, F.E., 1998, The impact of surface errors on fixture workpiece location and orientation, *Transactions of NAMRI*, 323-328.
- [9] Sangnui, S., Peters, F., 2001, The impact of surface errors on the location and orientation of a cylindrical workpiece in a fixture, *Journal of Manufacturing Science and Engineering*, 123: 325-330.
- [10] Tichadou, S., 2007, Quantification of machining and fixture dispersions for geometrical manufacturing simulation, 10th International CIRP seminar on Computer Aided Tolerancing, Erlangen.
- [11] Alistair, B-F., 1989, Least squares Best-fit geometric elements, NPL report.
- [12] Bourdet, P., Mathieu, L., Lartigue, C. and Ballu, A., 1996, The concept of the small displacement taylor in metrology, In *Advance Mathematical Tool in Metrology II*, Edited by Work Scientific Publishing Company, Series Advances in Mathematics for Applied Sciences, 40: 110-120.
- [13] El Maraghy, W., Bourdet, P., ElMaraghy, H., 2005, Small displacement taylor theory and various compensation schemes for complex form realization, CPI, Casablanca, Morocco.
- [14] Villeneuve F., Vignat F., Landon Y., 2001, Tolerancing for manufacturing: a three-dimensional model, *International Journal of Production Research*, 39: 1625-1648.
- [15] Kamalinejad, M., Vignat, F. and Villeneuve, F., 2009, Simulation of the geometrical defects of manufacturing, *International Journal of Advanced Manufacturing Technology*, 45(7-8): 631-648.
- [16] Sergent, A., Duret, D., Nguyen, D.S. and Villeneuve, F., 2008, Performances d'un moyen de mesure in situ sur M.O.C.N., *Contrôles essais mesures*, 22: 35-39.
- [17] Ramesh, R., Mannan, M.A., Poo, A.N., 2000, Error compensation in machine tools - a review: Part II: thermal errors, *International Journal of Machine Tools and Manufacture*, 40: 1257-1284.
- [18] Semyon G.R., 2005, *Measurement errors and uncertainties theory and practice*, Springer.