

Washington University in St. Louis

## Washington University Open Scholarship

---

Mechanical Engineering and Materials Science  
Independent Study

Mechanical Engineering & Materials Science

---

5-9-2018

### Mechanical Testing of Viscoelastic Alginate Hydrogels

Humza Ismail

*Washington University in St. Louis*

Jessica Wagenseil

*Washington University in St. Louis*

Follow this and additional works at: <https://openscholarship.wustl.edu/mems500>

---

#### Recommended Citation

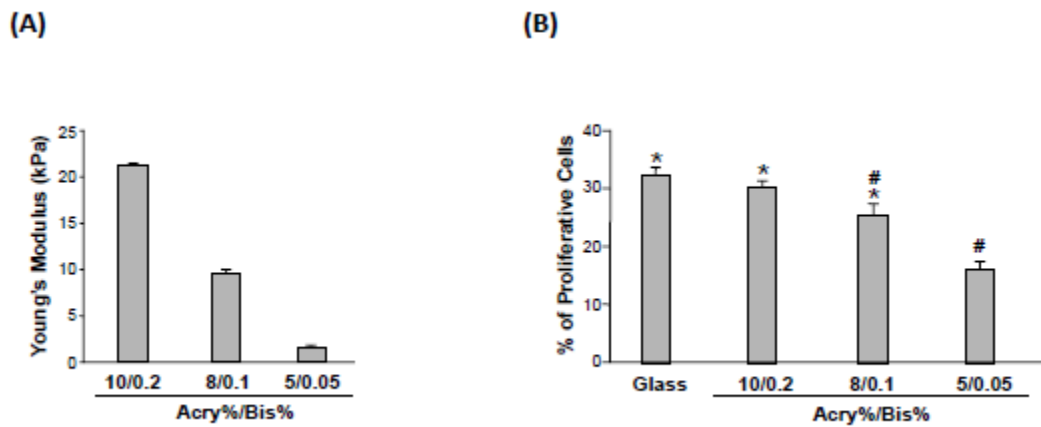
Ismail, Humza and Wagenseil, Jessica, "Mechanical Testing of Viscoelastic Alginate Hydrogels" (2018).  
*Mechanical Engineering and Materials Science Independent Study*. 66.  
<https://openscholarship.wustl.edu/mems500/66>

This Final Report is brought to you for free and open access by the Mechanical Engineering & Materials Science at Washington University Open Scholarship. It has been accepted for inclusion in Mechanical Engineering and Materials Science Independent Study by an authorized administrator of Washington University Open Scholarship. For more information, please contact [digital@wumail.wustl.edu](mailto:digital@wumail.wustl.edu).

## Introduction

The effect that the elastic properties of a three-dimensional extracellular matrix (ECM) has on cell growth, proliferation, and phenotype have long been established. The ECM can be described as a protein scaffold that contains polymers that help support and communicate with the cells that are growing on it. The model of dynamic reciprocity describes how the properties of the ECM (mechanical properties such as elastic modulus) can affect the cell's behavior and phenotype as a cell is forging its tissue specific identity.<sup>1</sup> It has been shown that the stiffness of the ECM substrate has an effect on the behavior of the cells that are growing in that ECM.<sup>2</sup> This effect can be seen through the phenotype of the cells growing on the ECM, the proliferation rate of the cells, and the growth rate of the cells.

Generally, it has been found that increasing the stiffness of the ECM will increase the proliferation of the cells growing on the ECM. An example of this can be seen with the work that was done by Yeh et al. in which they showed that hydrogels with varying stiffness values could be produced by mixing different amount of acrylamide and bis-acrylamide together. The team also showed that the stiffer the polyacrylamide substrate, the greater the percentage of cell proliferation was seen.<sup>3</sup> This can be seen below in Figure 1.

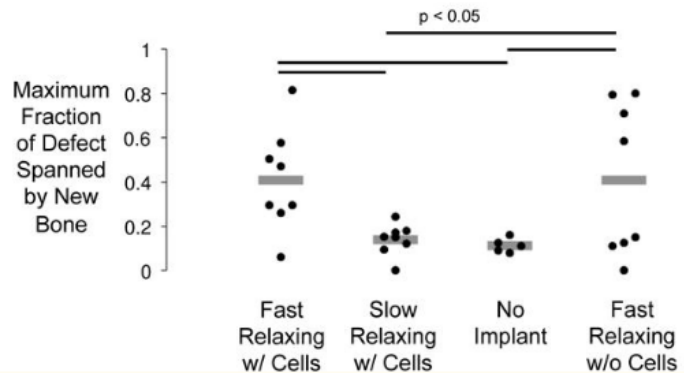


**Figure 1- The team of Yeh et al. showed in (A) that different combinations of acrylamide monomer and bis-acrylamide crosslinker yielded hydrogels of different stiffness. They also showed in (B) that the stiffer the artificial ECM, the higher percentage of endothelial cells proliferation was seen.**

However, since the effects of ECM stiffness on cell behavior are being readily established, the focus of inquiry is shifting into looking at how the viscoelastic properties, or the time related material properties, affect cell behavior. Cells grow in environments that are constantly changing. To truly understand how cells behave in the long term, it is necessary to consider how the ECM changes over time. It is long been known that the ECM is viscoelastic; however, it has only been recently that efforts are starting to be made into understanding what the viscoelastic properties of the ECM mean for the cells that are growing on the ECM.<sup>2</sup>

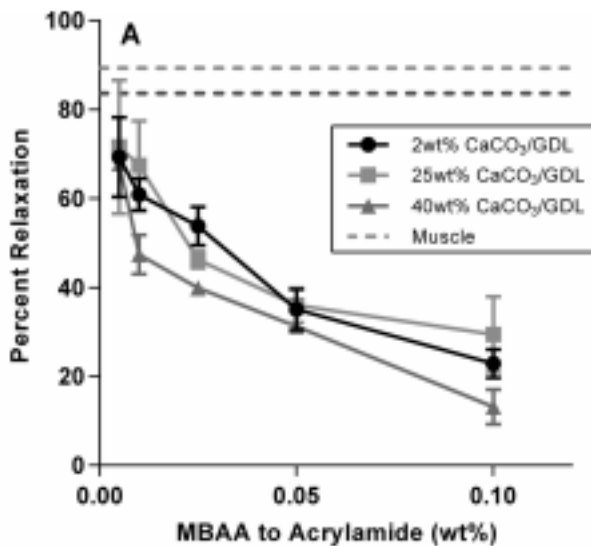
Attempts have been made to look at how the viscoelastic properties of the ECM play a role in cell behavior. For example, the team of Darnell et al, showed using fast-relaxing and

slow-relaxing alginate hydrogels that viscoelasticity influences the fraction of bone defect filled in by new bone.<sup>4</sup> They also found that fast relaxing gels without cells seeded onto them filled in almost the same amount of the bone defect as fast relaxing alginate gels with cells seeded onto them, with their being no statistical difference between the two groups as seen in Figure 2. The group asserted that these findings show that substrate relaxation can be a “potent regulator of bone formation *in vivo*,” a result that can lead scientists to have new tools when looking at how to bioengineer tissue beyond things like growth factors.<sup>4</sup>



**Figure 2- Fraction of wound area inhabited by new bone 3 months after injury in a rat model.**

The group of Fitzgerald et al. also found interesting results pertaining to tunable alginate-polyacrylamide hydrogels. The group fabricated hydrogels that used an interpenetrating network (IPN), which is a combination of two polymer networks where at least one of the networks was synthesized and crosslinked in the presence of the other network.<sup>5</sup> In this case, the two polymer networks were the alginate network and the polyacrylamide network. This led to hydrogels that were tunable in both their time-independent properties which could be controlled through the concentration ammonium persulfate (APS) used in the crosslinking of the polyacrylamide network. They also found that



**Figure 3- Plot showing that for a gel with a given CaCO<sub>3</sub>/GDL composition, the percent relaxation decreases as the MBAA percentage is increased. This shows that the time dependent properties can be tuned for alginate-polyacrylamide IPN gels.**

time-dependent parameters were tunable by varying the amount of bis-acrylamide (MBAA) used in the crosslinking of the polyacrylamide network relative to the total amount of acrylamide monomer used. This can be seen in Figure 3.<sup>5</sup>

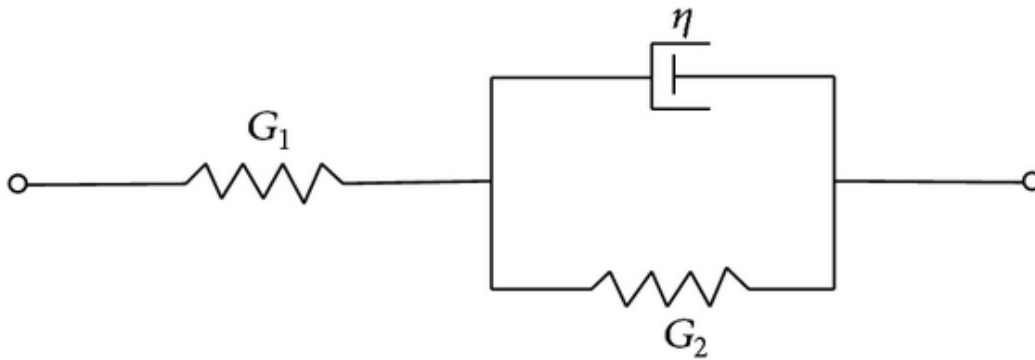
The team of Growney Kalaf et al. characterized slow gelling alginate gels that were ionically crosslinked with CaCO<sub>3</sub> for intervertebral disc applications.<sup>6</sup> The gels were characterized based off the ratio of CaCO<sub>3</sub>:GDL used in the gelation of the gel. The gels were then characterized using rheology and hysteresis

curves to see how the curves compared to each other and how the gels held their strength over time. In this experiment, Ionic gels were created in a similar fashion. Alginate gels that were

crosslinked covalently were also created. The goal of these experiments was to create gels that shared similar initial elastic properties but differed in their time dependent stress relaxation response. This paper goes into detail about the mechanical tests that were done in order to characterize the alginate gels that were fabricated.

### **The Three-Parameter Model**

In order to analyze the stress relaxation data that was gathered, a three-parameter model of linear viscoelasticity was used to characterize the behavior of the gels. The three-parameter model is a system of springs and dashpots that can describe the elastic and viscous response of the alginate gels respectively. The three-parameter model can be seen below in Figure 4.



**Figure 4- A representation of the three-parameter model using springs and dashpots. The springs help describe the elastic response of the substrate and the dashpot the viscous response.**

From this representation, the constitutive relationship of the model can be derived and written as:

$$\frac{1}{G_1} \frac{d\sigma(t)}{dt} + \frac{1}{\eta} \sigma(t) = \left(1 + \frac{G_2}{G_1}\right) \frac{d\varepsilon(t)}{dt} + \frac{G_2}{\eta} \varepsilon(t) \quad (1)$$

where  $\varepsilon(t)$  is the strain that is applied to the system as a function of time,  $\sigma(t)$  is the stress applied to the system over time,  $G_1$  and  $G_2$  are the elastic moduli of the three-parameter system and  $\eta$  is the viscous coefficient of the system.

From this equation, the stress-relaxation response of the model can be derived as:

$$G(t) = \frac{\sigma(t)}{\varepsilon_0} = G_2 + G_1 e^{\frac{-G_1}{\eta} t} \quad (2)$$

The stress relaxation function ( $G(t)$ ) is normalized by the initial strain that is put on the gel during the stress relaxation test. In these sets of tests, the initial strain was set to 10%.

Stress relaxation tests are used when the stress over time of a viscoelastic substrate needs to be quantified. The test is performed by applying a constant strain on the substrate (in this case the alginate gels), and monitoring the stress until an equilibrium value is achieved. For the three-parameter model, the equilibrium  $G(t)$  value, or  $G(\infty)$ , is the value of  $G_2$  from the diagram above in Figure 4.  $G(0)$  on the other hand represents  $G_1+G_2$ . From these two values from the stress relaxation curve for the three-parameter model, shown in Figure 5, the initial elastic response and the elastic response over time can be measured. From this, it is possible to see the initial elastic response of the alginate hydrogels and their time dependent response.

## Testing Procedure

In order to conduct stress relaxation tests on the hydrogels provided in this experiment, an Instron Universal loading frame was used with a 500N load cell attached to flat plate compression platens. Bluehill software was used to control the Instron and complete the stress relaxation tests. It was also used to conduct the hysteresis tests for the Ionically crosslinked alginate hydrogels.

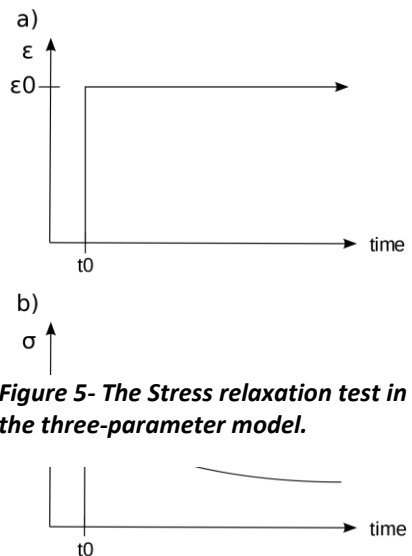
Stress Relaxation tests were conducted for 20 minutes for the ionically crosslinked alginate gels and 30 seconds for the covalently crosslinked alginate hydrogel. The huge discrepancy in the time tested is due to the difference in size of the gels. The ionically crosslinked hydrogels were on average about 33mm in diameter and about 9mm thick. The covalently crosslinked hydrogel was on average 0.9 mm in diameter and 4mm thick. Relaxation time for the covalent gel would be much higher for a larger gel.

The different gels tested were the x2, x3, x4, x5, and the covalently crosslinked alginate hydrogels. The strengths of the ionically crosslinked gels (x2, x3, x4, x5) refer to the amount of alginate used in relation to each other. The x1 alginate gel was not tested due to its inability to crosslink correctly.

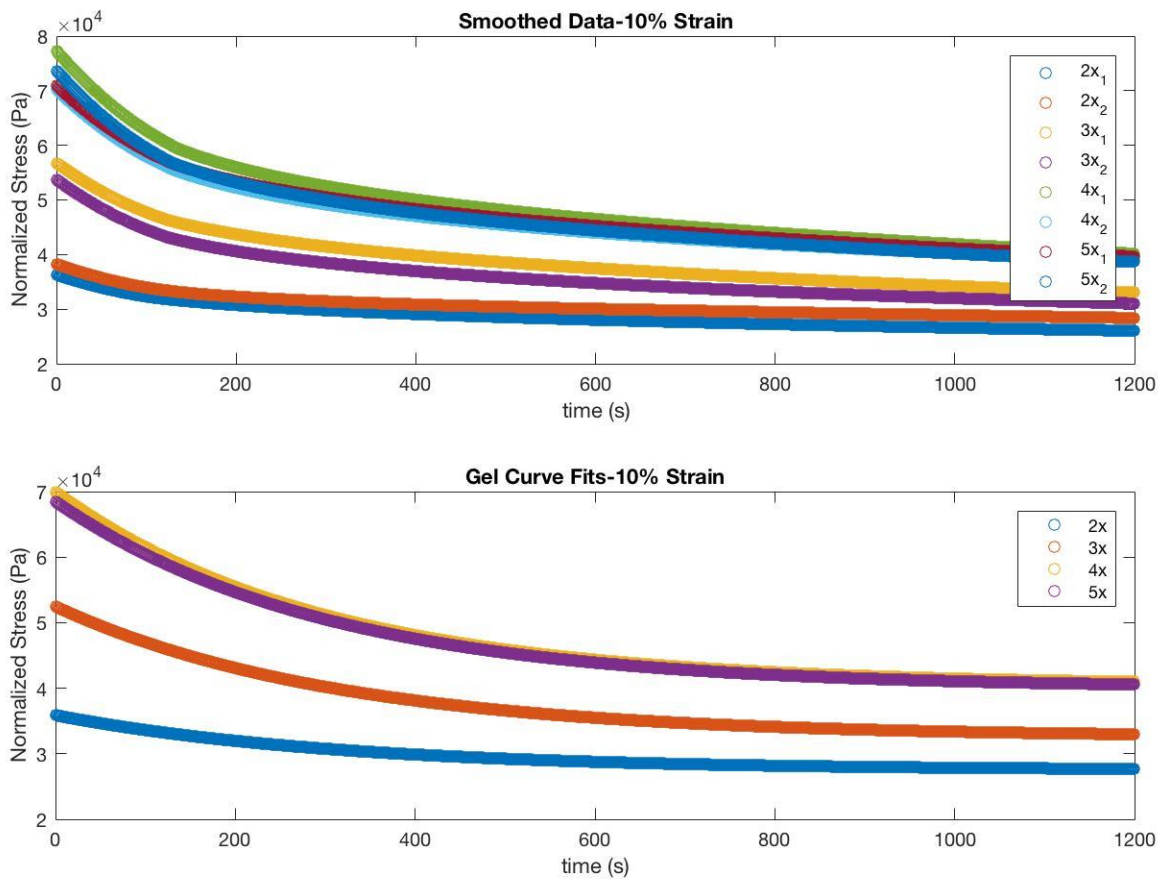
Hysteresis curves were also found for the ionically crosslinked alginate hydrogels.

## Results

The following curves represent the raw data,  $G(t)$ , of the captured from the Instron uniaxial testing device (top graph) and the curve fits that were found by using a square curve fit to find the parameters  $G_1$ ,  $G_2$ , and  $\eta$  (bottom graph). The two graphs can be seen below in Figure 6. The data shows that as the amount of Alginate increases, so does the initial elastic response. However, it seems that past a certain amount of alginate used, the initial response of the gel remains the same, lending to the idea that some sort of asymptote is reached. This also could be due to the fact that the alginate used to make the hydrogels was uncharacterized so its molecular weight was not known.

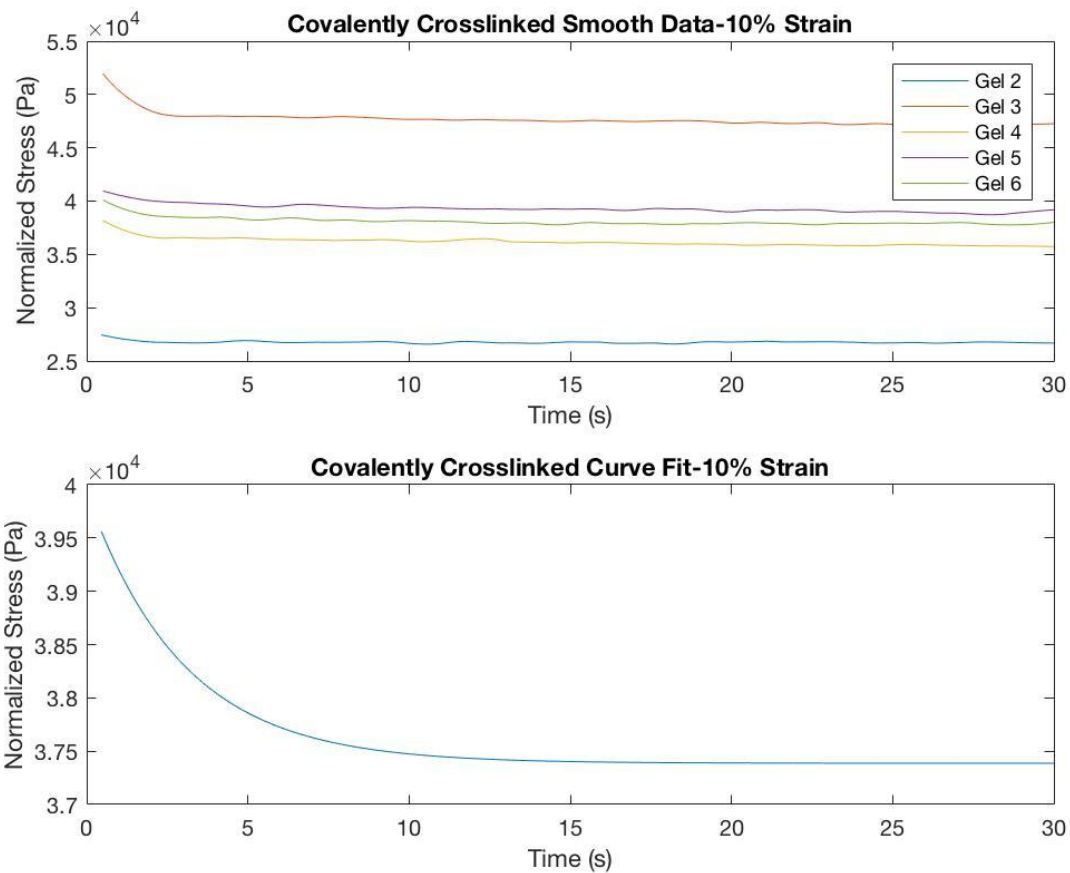


**Figure 5- The Stress relaxation test in the three-parameter model.**



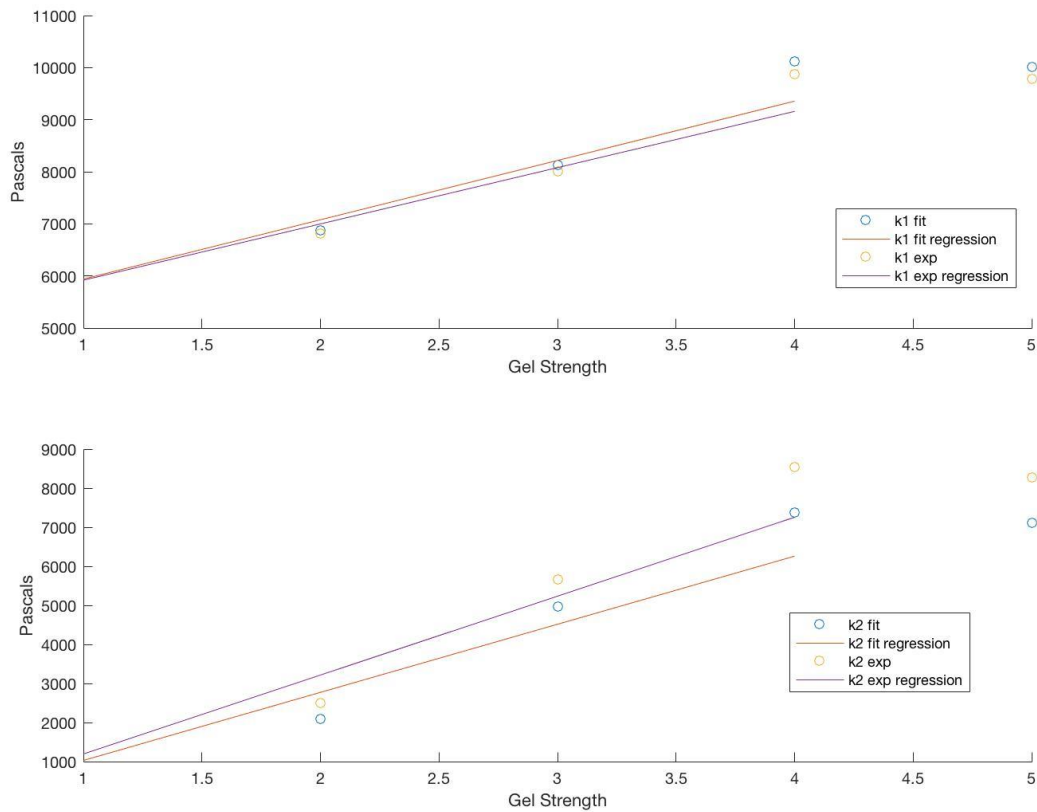
**Figure 6- Smoothed Stress Relaxation data (top) and stress relaxation curve fits (bottom). The graphs show that an increase in the amount of alginate used leads to a higher initial elastic response. This is not true when comparing the 4x and the 5x gels leading to the idea that gel strength may reach an asymptote when compared to increasing amounts of alginate used.**

The same curves were made for the covalently crosslinked alginate hydrogel. Figure 7 shows that the covalently crosslinked hydrogel has a stress relaxation response that is similar to that of the ionically crosslinked hydrogels.



**Figure 7- Stress Relaxation curves (smoothed data and square curve fit) for the covalently crosslinked alginate hydrogel.**

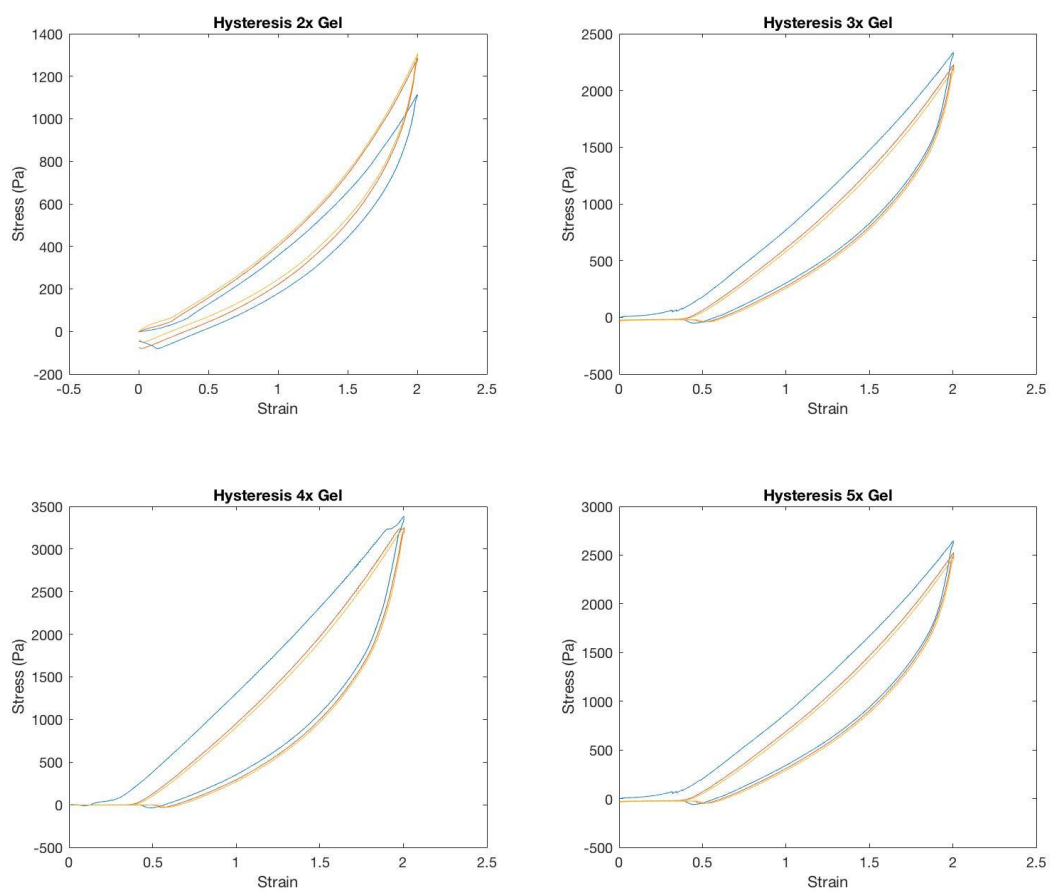
The  $G_1$  and  $G_2$  values for the different hydrogels were also compared and the data followed a similar trend. The values increase until the x4 gel. The x5 gel had lower value for  $G_1$  and  $G_2$  than the x4 gel. A linear fit was made of the data to prove that the ionically crosslinked gels were indeed linear viscoelastic. The decrease in moduli values from the x4 gel to the x5 gel data does not follow the expected trend. This trend was seen again in the in the hysteresis data below as well.



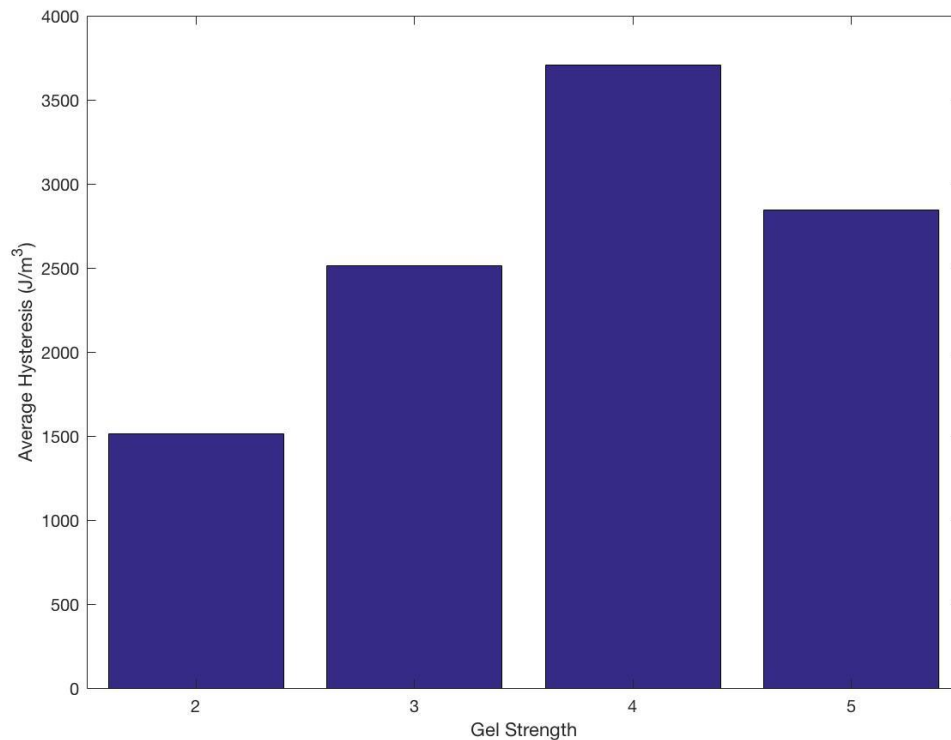
**Figure 8- Linear fits of the  $G_1$  and  $G_2$  (labelled  $k_1$  and  $k_2$  on the legend). The strength of the gels seems to increase linearly except for the x5 gel which does not seem to follow the pattern.**

Hysteresis Curves were also found for the ionically crosslinked hydrogels in an effort to quantify the amount that each ionically crosslinked hydrogel relaxed over time. The hysteresis curves for the four hydrogels can be seen below in Figure 9. The average hysteresis was taken by finding the area between the two curves and averaging the values over the three hysteresis loops completed for each gel. The average hysteresis is quantified in Figure 10 below.





**Figure 9- Hysteresis curves for the four ionically crosslinked alginate hydrogels.**



**Figure 10- The average hysteresis for the ionically crosslinked alginate hydrogels.**

As can be seen from Figure 10 above, it seems that as more alginate is used in the formation of the gel, the higher the stress relaxation seen is as indicated by the value of average hysteresis. Once again, the x5 gel does not follow this pattern. In fact, it has an average hysteresis that is lower than that of the x4 gel.

## **Discussion**

From the data presented in the previous section, a few observations can be made. The first observation is that alginate gels that were made using both ionic and covalent crosslinking were both successfully characterized.  $G_1$  and  $G_2$  values for both types of gels were measured and it was proven that the alginate gels are truly linear viscoelastic (as shown in Figure 8). However, the x5 gel, the gel that should have had the highest values for initial elastic strength and highest average hysteresis had values lower than the x4 gel. This can be due to several reasons. One reason is that there could be an error in the way that the x5 ionically crosslinked alginate hydrogel was fabricated. However, since this study did not fabricate the gels and only characterized them mechanically, it is difficult to say if there was a problem in the fabrication process. It may also be that after adding a certain amount of alginate to a hydrogel, the stiffness properties of the gel start to decrease. Further testing is needed on the subject.

Now that alginate hydrogels have been successfully fabricated and mechanically characterized, the next step is to seed cells into the alginate and monitor cell proliferation and

phenotype. There has already been work that has been done in this area. Chaudhuri et al. found that cell spreading, proliferation, and osteogenic differentiation of mesenchymal stem cells were all enhanced in cells cultured in gels with faster relaxation.<sup>7</sup> The team of Bauer et al. found similar results when they showed that myoblasts had greater proliferation on hydrogels that exhibited stress relaxation when compared to elastic hydrogels that shared similar elastic moduli.<sup>8</sup>

## **Conclusion**

This experiment showed that alginate hydrogels that were crosslinked either ionically or covalently both exhibited stress relaxation characteristics that could be characterized. Using stress relaxation tests with an initial strain of 10%, the initial elastic properties of the gels could be identified and compared. The average hysteresis for the ionically crosslinked hydrogels also was characterized and showed that generally, the more alginate used in fabricating a hydrogel, the more stress relaxation that gel exhibited. The x5 gel did not agree with this trend. As previously stated, more testing into why this gel did not follow the trend is needed. Overall, it has been proved that alginate hydrogels are a suitable candidate to be used for studying how the viscoelastic properties of the ECM affect the behavior of the cells that are interacting with that ECM.

## References

1. C. M. Nelson and M. J. Bissell, Of Extracellular Matrix, Scaffolds, and Signaling: Tissue Architecture Regulates Development, Homeostasis, and Cancer, *Annu. Rev. Cell Dev. Biol.*, 2010, 22, 287–309.
2. Chaudhuri, Ovijit. “Viscoelastic Hydrogels for 3D Cell Culture.” *Biomaterials Science*, The Royal Society of Chemistry, 6 June 2017,
3. Yeh, Yi-Ting, et al. “Matrix Stiffness Regulates Endothelial Cell Proliferation through Septin 9.” *PLoS ONE*, Public Library of Science, 2012, [www.ncbi.nlm.nih.gov/pmc/articles/PMC3485289/](http://www.ncbi.nlm.nih.gov/pmc/articles/PMC3485289/).
4. Darnell, Max, et al. “Substrate Stress-Relaxation Regulates Scaffold Remodeling and Bone Formation in Vivo.” *Advances in Pediatrics.*, U.S. National Library of Medicine, 20 Dec. 2016, [www.ncbi.nlm.nih.gov/pmc/articles/PMC5440842/](http://www.ncbi.nlm.nih.gov/pmc/articles/PMC5440842/).
5. Fitzgerald, M M, et al. “Tunable Stress Relaxation Behavior of an Alginate-Polyacrylamide Hydrogel: Comparison with Muscle Tissue.” *Advances in Pediatrics.*, U.S. National Library of Medicine, 11 May 2015, [www.ncbi.nlm.nih.gov/pubmed/25812913](http://www.ncbi.nlm.nih.gov/pubmed/25812913).
6. Growney Kalaf, Emily A, et al. “Characterization of Slow-Gelling Alginate Hydrogels for Intervertebral Disc Tissue-Engineering Applications.” *Materials Science and Engineering: C*, Elsevier, 27 Feb. 2016, [www.sciencedirect.com/science/article/pii/S092849311630159X?via=ihub](http://www.sciencedirect.com/science/article/pii/S092849311630159X?via=ihub).
7. Chaudhuri, O, et al. “Hydrogels with Tunable Stress Relaxation Regulate Stem Cell Fate and Activity.” *Advances in Pediatrics.*, U.S. National Library of Medicine, Mar. 2016, [www.ncbi.nlm.nih.gov/pubmed/26618884](http://www.ncbi.nlm.nih.gov/pubmed/26618884).
8. Bauer, A, et al. “Hydrogel Substrate Stress-Relaxation Regulates the Spreading and Proliferation of Mouse Myoblasts.” *Advances in Pediatrics.*, U.S. National Library of Medicine, 15 Oct. 2017, [www.ncbi.nlm.nih.gov/pubmed/28864249](http://www.ncbi.nlm.nih.gov/pubmed/28864249).