

Washington University in St. Louis

Washington University Open Scholarship

Mechanical Engineering Design Project Class

Mechanical Engineering & Materials Science

Fall 2018

Group L: T-shirt2 Cutter

Sophie Anderson

Washington University in St. Louis

Avery German

Washington University in St. Louis

Taylor Tuleja

Washington University in St. Louis

Follow this and additional works at: <https://openscholarship.wustl.edu/mems411>



Part of the [Mechanical Engineering Commons](#)

Recommended Citation

Anderson, Sophie; German, Avery; and Tuleja, Taylor, "Group L: T-shirt2 Cutter" (2018). *Mechanical Engineering Design Project Class*. 107.

<https://openscholarship.wustl.edu/mems411/107>

This Final Report is brought to you for free and open access by the Mechanical Engineering & Materials Science at Washington University Open Scholarship. It has been accepted for inclusion in Mechanical Engineering Design Project Class by an authorized administrator of Washington University Open Scholarship. For more information, please contact digital@wumail.wustl.edu.



Washington University in St. Louis

SCHOOL OF ENGINEERING & APPLIED SCIENCE

Executive Summary

The T-shirt square cutter was commissioned by fashion design professor at Washington University, Dr. Mary Ruppert-Stroescu who has developed a method of turning T-shirts that might have otherwise been thrown away into a unique, woven fabric. Dr. Ruppert-Stroescu cuts T-shirts into either strips or squares that she then quilts together, she uses this fabric to make one-of-a-kind clothes, bags, and rugs. Though she is proficient at weaving the fabric scraps together, cutting the T-shirts was a very time-consuming process – it takes her at least 20 minutes to cut a T-shirt into squares by hand. Our team was tasked with designing and building a machine that would speed up the cutting process for her. With a budget of \$250, we have spent the semester designing, building, and testing a machine that would cut T-shirts into squares safely and with minimal effort from the user. This report details the entire design process, beginning with the assessing user needs so we could brainstorm ideas. After a concept was selected based on certain criteria, we built and tested a proof of concept. After assessing the failures and successes of the proof of concept prototype we were able to build a final prototype that was ultimately able to successfully cut a T-shirt into squares.

**MEMS 411: MECHANICAL ENGINEERING DESIGN PROJECT
FALL 2018**

Project Name

Sophie Anderson

Avery German

Taylor Tuleja

TABLE OF CONTENTS

List of Figures	3
List of Tables	4
1 Introduction.....	5
2 Problem Understanding.....	6
2.1 Background Information Study.....	6
2.2 User Needs	9
2.3 Design Metrics	10
2.4 Project Management	10
3 Concept Generation.....	11
3.1 Mockup Prototype.....	11
3.2 Functional Decomposition	11
3.3 Alternative Design Concepts	13
4 Concept Selection	16
4.1 Selection Criteria.....	16
4.2 Concept Evaluation.....	17
4.3 Evaluation Results.....	17
4.4 Engineering Models/Relationships	18
5 Concept Embodiment.....	20
5.1 Initial Embodiment	20
5.2 Proof-of-Concept	24
6 Working Prototype.....	26
6.1 Overview.....	26
6.2 Demonstration Documentation	26
6.3 Experimental Results	28
7 Design Refinement.....	30
7.1 FEM Deflection Analysis.....	30
7.2 Design for Safety	31
7.3 Design for Manufacturing.....	33
7.4 Design for Usability	35
8 Discussion.....	37
8.1 Project Development and Evolution	37
8.2 Design Resources.....	38
8.3 Team Organization.....	39
Appendix A – Cost Accounting Worksheet.....	41
Appendix B – Final Design Documentation	42

LIST OF FIGURES

Figure 1 Example of a pattern made with Professor Mary Ruppert-Stroescu's square t-shirt recycling and manufacturing method.....	5
Figure 2 Hercules HRK-100 3-Speed Octagonal Rotary Cutter	6
Figure 3 Pink Power Lithium Ion Cordless Electric Scissors	6
Figure 4 Go! Fabric Cutter.....	7
Figure 5 Noodle cutter, patent US963682A.....	8
Figure 6 Paper cutting machine, patent US5069097A.....	8
Figure 7 T-Shirt Cutter Gantt Chart	10
Figure 8 Orthographic view	11
Figure 9 Construction of the mockup	11
Figure 10 Isometric view of the mockup	11
Figure 11 Function tree for TSC	11
Figure 12 Morphological chart	12
Figure 13 Taylor's design concept	13
Figure 14 Sophie's design concept.....	14
Figure 15 Avery's design concept.....	15
Figure 16 Dimensions of threaded rod.....	19
Figure 17 Basic views of the T-shirt cutter embodiment assembly in SolidWorks	20
Figure 18 Assembly drawing with Bill of Materials.....	21
Figure 19 Exploded view of assembly	22
Figure 20 SolidWorks drawing of protective blade case	23
Figure 21 PoC prototype in use and after producing squares.	25
Figure 22 The slotted guide for the blade array painted with Plasti-Dip to keep the T-shirts in place.....	26
Figure 23 A motor test with the blade array prior to operation.....	27
Figure 24 The T-shirt ² Cutter in use with a purple shirt in between the waffle base and the slotted guide.....	27
Figure 25 The blade array inside the blade case, resting atop the slotted guide	28
Figure 26 The first two squares cut by the T-shirt ² Cutter PoC compared to the 20 squares cut by the working prototype.....	28
Figure 27 Mesh, loads, and fixtures of blade shaft	30
Figure 28 FEM deflection analysis results.....	31
Figure 29 Risk assessment heat map.....	33
Figure 30 Original draft analysis on blade case.....	34
Figure 31 draft analysis on blade case with 3° draft	34
Figure 32 Issues present for a mill/drill only manufacturing process.....	34
Figure 33 Issues for an injection molding manufacturing process.....	35

LIST OF TABLES

Table 1: Customer Needs Interview.....	9
Table 2: Interpreted Customer Needs	10
Table 3: Target Specifications	10
Table 4 AHP with seven criteria for design.....	16
Table 5 Weighted scoring matrix to determine the design configuration.....	17
Table 6 Initial parts list of prototype components	24

1 INTRODUCTION

Professor Mary Ruppert-Stroescu has produced a technique to make fabric from old T-shirts that have been cut up into strips or squares. The new fabric is low-waste, aesthetically appealing, customizable, and easy to replicate once an initial template has been made. However, the process currently being used to cut old T-shirts is labor intensive and time consuming. In order for this technique to be scalable, a faster method for T-shirt cutting is needed. Our team has developed a T-shirt Square Cutter (TSC) to assist Dr. Ruppert-Stroescu and her students in the manufacturing of the squares of fabric used in her patented clothing manufacturing technique. The machine consists of five parts: the base plate (will be referred to as a waffle base in the future based on appearance), the top plate (will be referred to as the slotted guide in the future based on appearance and usage), the rod with blades (will be referred to as the blade array in the future), the blade case, and the motor. The T-shirts will fit in between the waffle base and the slotted guide, and the two plates will be fastened together tightly with wing-nuts. Once they are fastened, the blade array, powered by the motor, and securely in the case, will be guided to cut the shirts by the user. The use of the machine will be explained in more detail in later sections.

Figure 1 below shows an image of one of the patterns that can be made with Professor Mary Ruppert-Stroescu's manufacturing method from cut T-shirt squares.

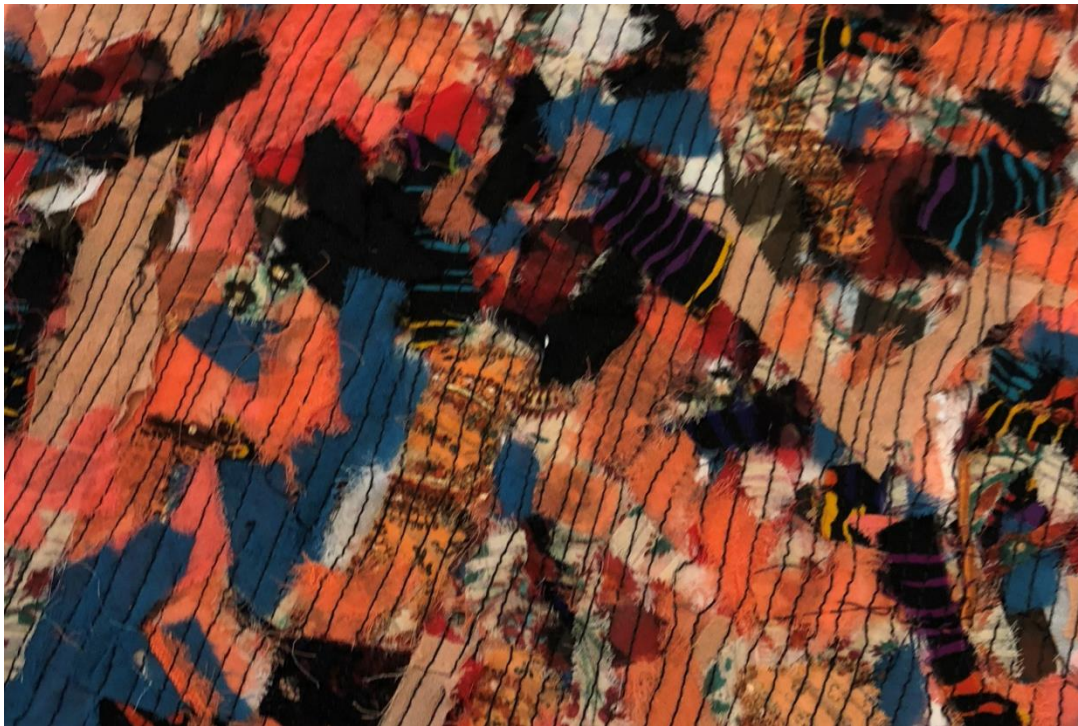

Figure 1 Example of a pattern made with Professor Mary Ruppert-Stroescu's square t-shirt recycling and manufacturing method

2 PROBLEM UNDERSTANDING

2.1 BACKGROUND INFORMATION STUDY

Existing Designs

Hercules HRK-100 3-Speed Octagonal Rotary Cutter

Previously, Dr. Ruppert-Stroescu has used the Hercules Cutter, shown in Fig. 2 below, to cut old T-shirts into strips. The Hercules Cutter includes an octagonal blade that can cut multiple layers of fabric up to 4" thick and an attached sharpening stone that can be operated by the user whenever necessary. The lower blade prevents the fabric from jamming. To operate, the user simply guides the Hercules Cutter along whatever lines need to be cut, similarly to a pizza cutter. This product is more expensive than other widely available fabric cutters, around \$120-\$160, but is consistently highly rated by customers.



Figure 2 Hercules HRK-100 3-Speed Octagonal Rotary Cutter

Image from: <https://www.universalsewing.com/tek9.asp?pg=products&specific=1%60329160>

Pink Power Lithium Ion Cordless Electric Scissors

The Pink Power Electric Scissors, Fig. 3, are designed to easily cut fabric, metal, paper, and cardboard with minimal effort from the user. These scissors include a top and bottom blade that have been motorized so they move up and down to cut fabric, much like a pair of traditional scissors would. The blades are moving much faster however, allowing the blades to easily glide through whatever they are cutting. The Pink Power electric scissors are cordless with a rechargeable battery, have a comfortable grip, and blades that can be easily changed. This product is lightweight, can cut through fabric or paper up to 1/2", and is less than \$30.



Figure 3 Pink Power Lithium Ion Cordless Electric Scissors

Image from: <https://www.walmart.com/ip/Pink-Power-Lithium-Ion-Cordless-Electric-Scissors-for-Crafts-Fabric-and-Scrapbooking/644088811>

Go! Fabric Cutter

The Go! Fabric Cutter, shown in Fig. 4, uses the same process as a die-cut machine to cut uniform shapes from fabric. It works by layering fabric on top of a die engraved with squares. A cutting map is placed onto the fabric and the user turns the handle to roll everything through the cutter. The roller compresses the fabric into the die, cutting shapes into the fabric. The Go! Fabric Cutter can cut up to 6 layers of cotton into uniform shapes. The Go! Fabric Cutter is the most expensive at \$300 but is marketed to cut fabric quickly and more accurately than rotary cutters and scissors.



Figure 4 Go! Fabric Cutter

Image from: https://www.accuquilt.com/fabric-cutting-machines/go-fabric-cutter-aq/go-fabric-cutter-starter-set.html?gclid=CjwKCAjwrNjcBRA3EiwAIIovq9t-0mQ4MTuNcd7rD95k2JvHBd_-fwSU5CFyyxBEGy3Y3_bCtcsmZhoCg6cQAvD_BwE

Related Patents

Noodle-cutter

US963682A

This is a handheld noodle cutting tool that allows the user to efficiently cut several uniform strips of noodle from rolled dough. This design includes a means to easily remove the blades from the frame for cleaning or sharpening. Additionally, the frame is designed to strip the cut dough away from the blades to prevent the device from getting clogged while in use. This noodle cutter is shown in Fig. 5.

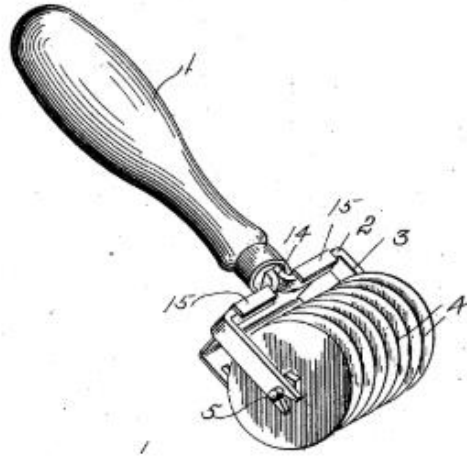

Figure 5 Noodle cutter, patent US963682A

Paper-cutting machine and method of cutting paper

US5069097A

The paper cutter is shown in Fig. 6. This paper cutter design works by sliding a blade (labeled 40) down a rail to cut paper or a stack of paper in a straight line. In this design, paper is intended to be placed on the board. The rail is lowered onto the paper clamping the paper in place. The slider is moved along the rail, the rotating blade will cut the paper as it moves. The clamping method sets this paper cutter apart from the rest and will prevent any offset that might occur during cutting.

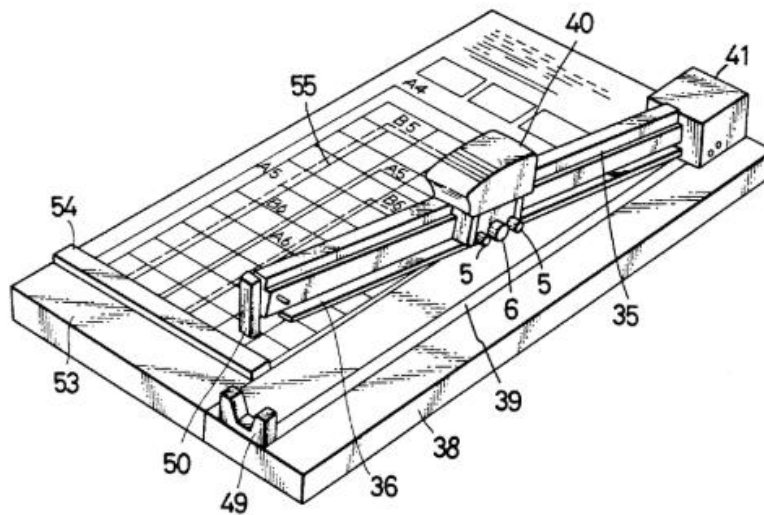

Figure 6 Paper cutting machine, patent US5069097A

Relevant Codes and Standards

Textile machinery – Safety Requirement – Part 1: Common Requirements

ISO 11111-1:2016

This standard describes safety requirements and standards for various machines used within the textile industry, including processing of fabric. It details appropriate machinery use for fabric cutting devices, including how they should be used and maintenance of the machines. Because we are concerned with cutting T-shirts these standards will help us to understand how we can approach this problem safely and potential hazards that we should be aware of.

Textile machinery – Guide to the design of textile machinery for reduction of the noise emissions

ISO 23771:2015

This standard includes information about how to develop low-noise textile machines, potential sources of noise in textile machines, and reducing noise emissions of textile machines. Because many of the existing machines for the quick cutting of fabrics are motorized, there is a chance that the T-shirt² cutter design will also be motorized. If this is the case, this standard could be important for us to understand how and why to eliminate associated noise.

2.2 USER NEEDS

Table 1 below shows the Customer Needs Interview divided into the question topic, customer response, and an interpreted need and importance by the design team.

Table 1: Customer Needs Interview

Question	Customer Statement	Interpreted Need	Importance
Likes (Current Product, Rotary Cutter)	Stone sharpener built into device	Blades must maintain sharp edge, or have sharpening abilities.	5
	Cuts thick stacks of fabric at once	Device should accommodate multiple shirts at once	4
Desired Size	Device should fit on a tabletop and be able to be stored in a closet	Device is compact and easy enough to carry; compactness is preferred, but portability is not necessary.	3
Dislikes (Current Product)	Could not make straight lines and took a lot of time	Device cuts consistently and quickly with a straight cutting edge	3
Desired Square Shapes	Customer showed us a sample of pre-cut shirts	Device cuts shirts into 1in x 1in squares. They do not all have to be exactly the same size, nor perfectly square	3

Table 2 below shows the Interpreted Customer Needs, ranking the need by importance to be factored into design considerations.

Table 2: Interpreted Customer Needs

Need Number	Need	Importance
1	T-Shirt cutter is always sharp/able to cut	5
2	TSC cuts shirts faster than current method	4
3	TSC is compact	3
4	TSC cuts consistent squares	3
5	TSC is easy to use	5
6	TSC is safe	5

2.3 DESIGN METRICS

Table 3 below shows a Target Specification table, where a standard for analysis of meeting user needs is described in detail.

Table 3: Target Specifications

Metric Number	Associated Needs	Metric	Units	Acceptable	Ideal
1	3	Total Weight	kg	<20	<10
2	3	Total Volume	m ³	<0.150	<0.10
3	2,4	Quickness	Shirts cut per minute	5	15
4	4,5	Consistency: Pieces have 4 sides, are no larger than 2in x 2in, and no smaller than 0.75 in x 0.75in	Binary	Yes	Yes
5	1	Maintains sharp cutting edge (built in sharpener) OR blades are replaceable	Binary	Yes	Yes

2.4 PROJECT MANAGEMENT

Figure 7 is a Gantt Chart highlighting the time it delegated and taken to complete each task throughout the making of the T-shirt² Cutter.

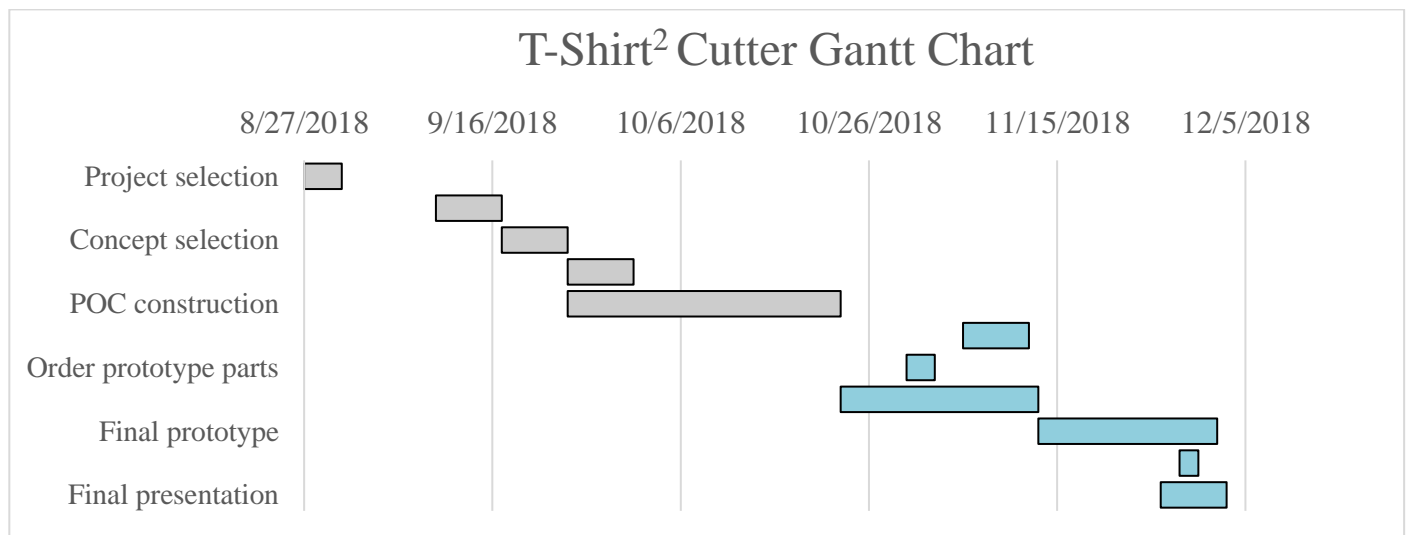

Figure 7 T-Shirt Cutter Gantt Chart

3 CONCEPT GENERATION

3.1 MOCKUP PROTOTYPE

Creating the mockup shown in Figures 8, 9, and 10 highlighted very specific hurdles that the group will face when building the final TSC.

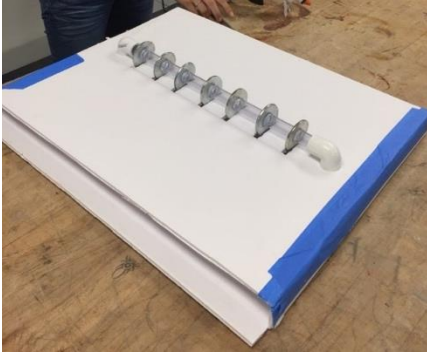

Figure 8 Orthographic view



Figure 9 Construction of the mockup

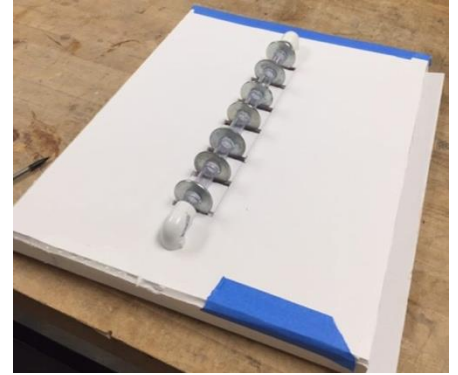

Figure 10 Isometric view of the mockup

The biggest hurdle will be creating a user-safe model which will perform adequately and also mask the blades from coming into contact with the operator; or, more specifically, from being able to pull in any of the operators own clothing. From the mockup prototype, the team was able to visualize the machine to size, which aided in modifying the design concept by coming up with two more possible blade configurations to create squares. Overall, the mockup was helpful in identifying and grasping the scale of difficulty that the TSC creation will present the team, and come up with more possible designs.

3.2 FUNCTIONAL DECOMPOSITION

Figure 11 shows a function tree for the TSC, outlining the main functional design aspects which need to be taken into consideration.

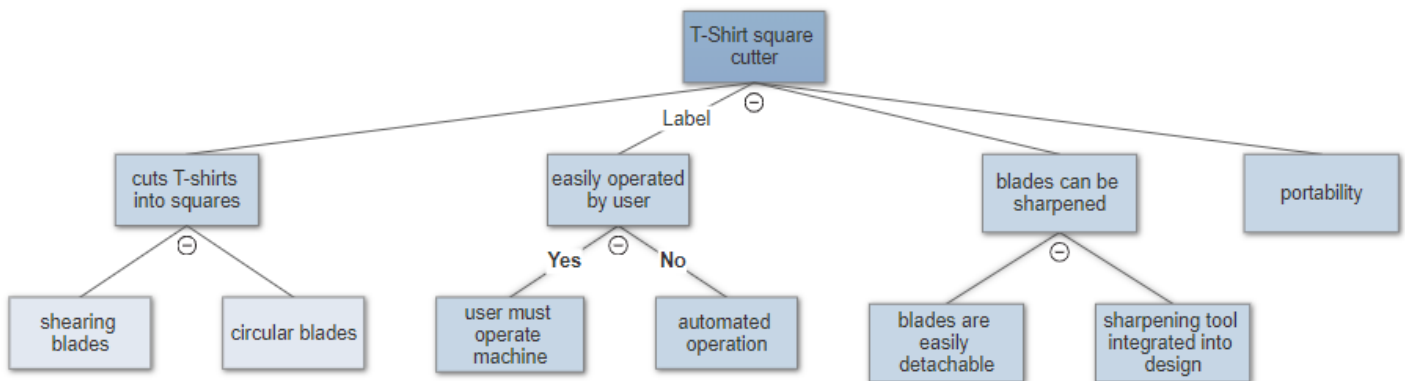

Figure 11 Function tree for TSC

Figure 12 shows a morphological chart for the T-shirt Cutter.

<p>Integrated Blade Sharpening Tool</p>	<p>Slotted Grindstone sent thru machine</p> <p>Detachable blades + Standalone Sharpener</p> <p>Grindstone attaches to Blade</p>
<p>Blade Configuration</p>	<p>Array of Shears</p> <p>Array of Circular Blades</p> <p>Cylindrical Waffle Blade</p>
<p>Interface with Tabletop</p>	<p>Rubber Feet</p> <p>Clamp</p> <p>Bolts</p>
<p>Quick, Cutting Capability</p>	<p>Many Shirts at once</p> <p>One at a time, rapid feed</p>
<p>Capable of Cutting 1 inch Squares Consistently</p>	<p>Orthogonal Blades</p> <p>Single Set of Blades + rotating Base</p>
<p>Human Powering Mechanism</p>	<p>Lever arm</p> <p>Crank on Blades</p> <p>Crank + Gear</p>

Figure 12 Morphological chart

3.3 ALTERNATIVE DESIGN CONCEPTS

Shown in Figures 13, 14, and 15 are individual design concepts made by each team member.

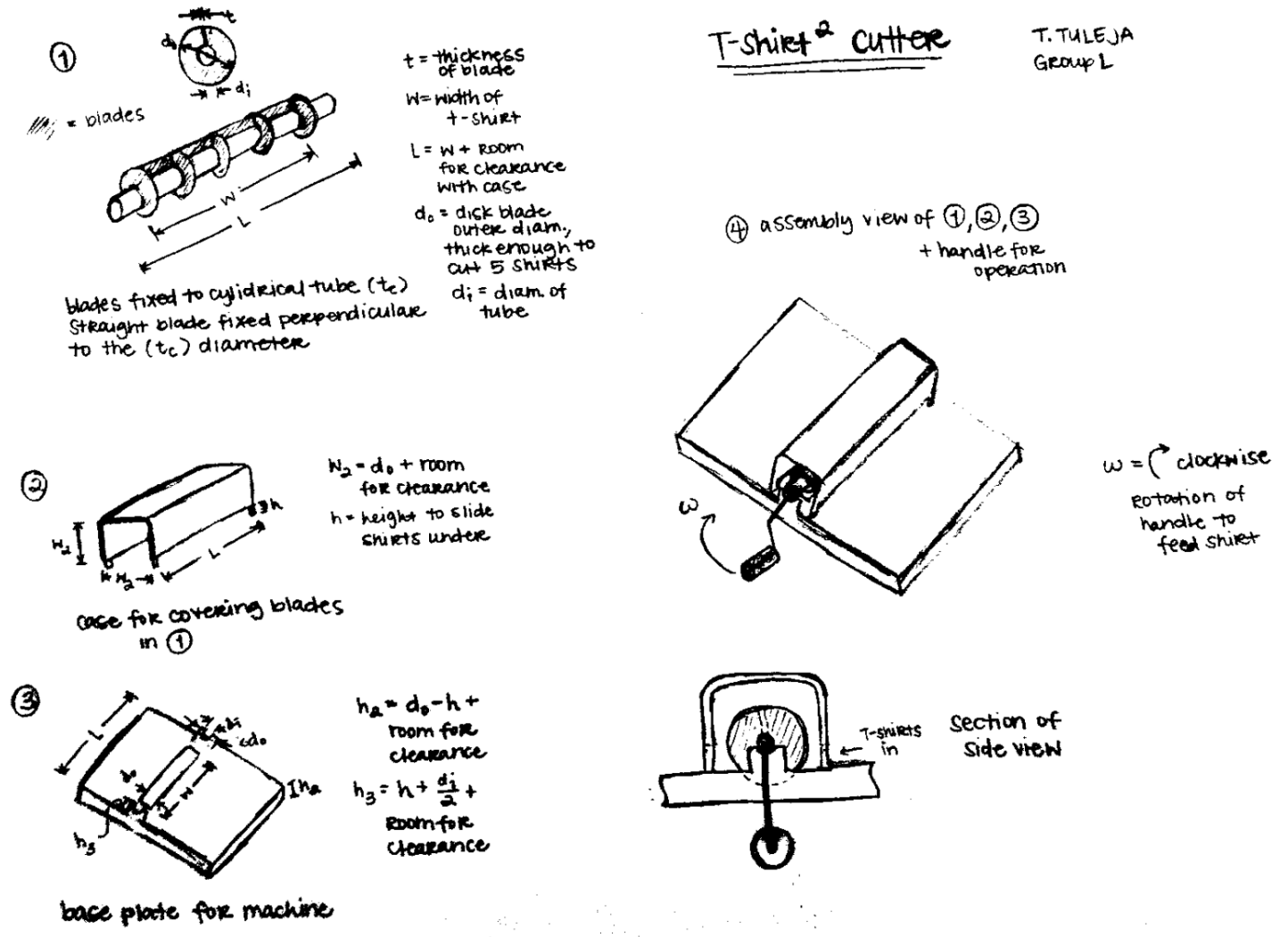

Figure 13 Taylor's design concept

Figure 13 shows Taylor's original design concept. The image shows an encased row of circular blades that cut up to five t-shirts at once into uniform squares via human powered work.

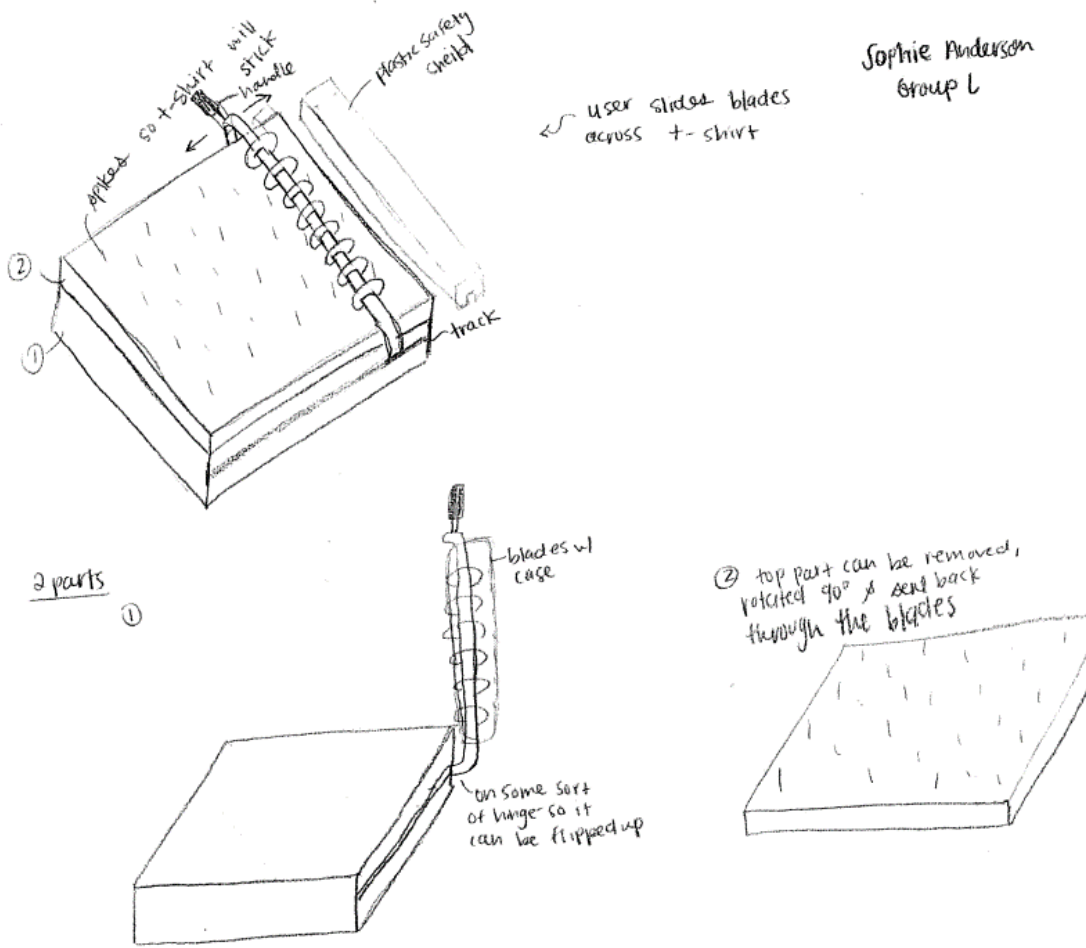
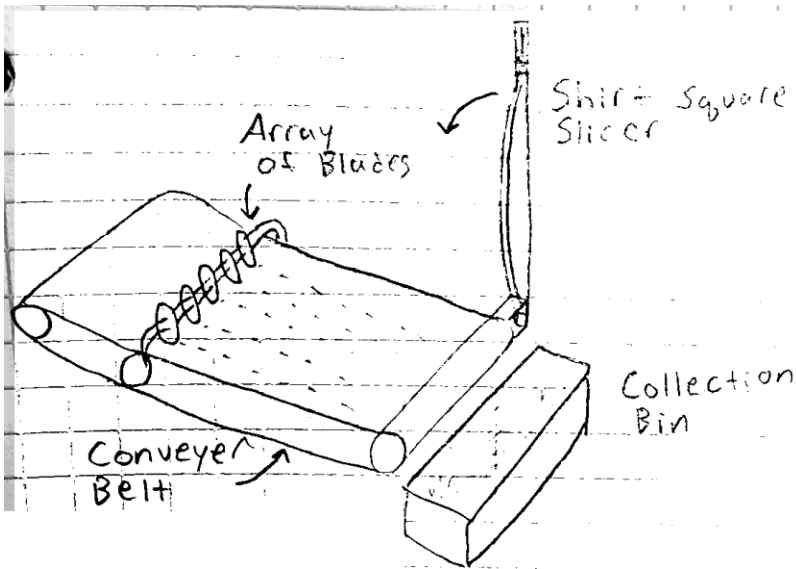

Figure 14 Sophie's design concept

Figure 14 shows Sophie's original design concept. A t-shirt is placed on the top layer of the machine, the user slides the blades across the t-shirt cutting strips into it. The top layer can be removed, rotated 90°, and placed back on. The user slides the blades across the shirt once again, cutting strips the other direction and creating squares.



Two Stage Shirt Cutter.

1. Circular Blades
Cut shirt into strips
2. Slicer repeatedly cuts
strips into squares

Features:

- Continuous feed,
One shirt at a time
- Conveyer belt moves
shirt through blades

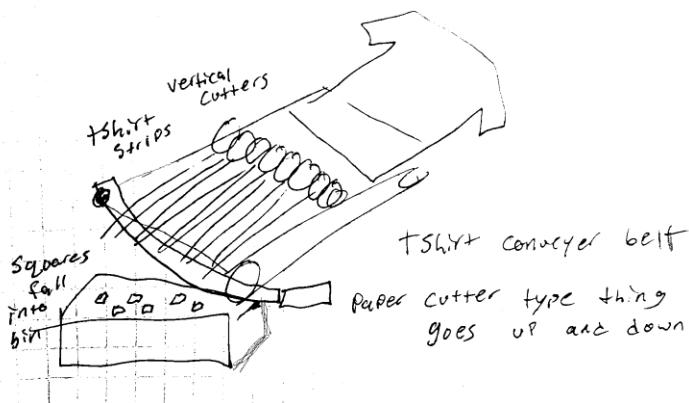

Figure 15 Avery's design concept

Figure 15 shows Avery's original design concept. Shirts are individually fed down a conveyer belt where an array of rotating blades cuts the shirt into thin strips. The conveyer belt continues to feed the strips down to a repeating slicer which cuts the strips into small squares. The squares are then collected in a bin.

4 CONCEPT SELECTION

4.1 SELECTION CRITERIA

Table 4 shows the Analytical Hierarchical Process (AHP) with six selection criteria. This process was used to determine weight values for each criterion necessary in the creation of the T-Shirt² cutter for Professor Mary Ruppert-Stroescu.

Table 4 AHP with seven criteria for design.

Criteria	Integrated Blade Sharpening Tool	Blade Configuration	Interface with Tabletop	Quick, Cutting Capability	Capable of cutting 1” squares consistently	Human Powering Mechanism	Safety Mechanism	Row Total	Weight Value	Weight %	Rank
Integrated Blade Sharpening Tool	1.00	5.00	7.00	3.00	1.00	5.00	0.33	22.33	0.19	19.34	2
Blade Configuration	0.20	1.00	7.00	0.20	0.14	3.00	0.14	11.69	0.10	10.12	5
Interface with Tabletop	0.14	0.14	1.00	0.14	0.20	3.00	0.14	4.77	0.04	4.13	6
Quick, Cutting Capability	0.33	5.00	7.00	1.00	0.33	3.00	0.14	16.81	0.15	14.56	4
Capable of cutting 1” squares consistently	1.00	7.00	5.00	3.00	1.00	3.00	0.20	20.20	0.17	17.49	3
Human Powering Mechanism	0.20	0.33	0.33	0.33	0.33	1.00	0.14	2.68	0.02	2.32	7
Safety Mechanism	3.00	7.00	7.00	7.00	5.00	7.00	1.00	37.00	0.32	32.04	1
Column Total								115.48	1.00	100.0	

4.2 CONCEPT EVALUATION

Table 5 shows the weighted scoring matrix used to determine the best design configuration for the T-Shirt² Cutter.

Table 5 Weighted scoring matrix to determine the design configuration.

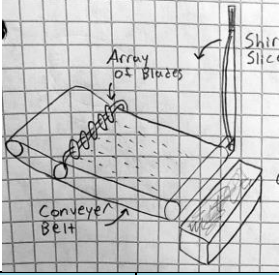
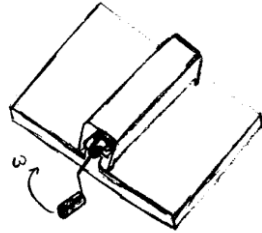
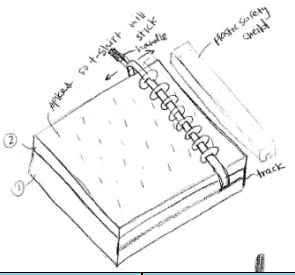
		Concept					
		Paper Cutter		Waffle Blade		Slide Slicer	
							
Selection Criterion	Weight (%)	Rating	Weighted	Rating	Weighted	Rating	Weighted
Integrated Blade Sharpening Tool	19.34	3	0.5802	2	0.3868	3	0.5802
Blade Configuration	10.12	3	0.3036	4	0.4048	3	0.3036
Interface with Tabletop	4.13	3	0.1239	3	0.1239	3	0.1239
Quick, Cutting Capability	14.56	3	0.4368	5	0.728	4	0.5824
Capable of cutting 1" squares consistently	17.49	3	0.5247	4	0.6996	5	0.8745
Human Powering Mechanism	2.32	3	0.0696	4	0.0928	4	0.0928
Safety Mechanism	32.04	3	0.9612	4	1.2816	3	0.9612
Weighted Sum		3		3.7175		3.5186	
Rank		3		1		2	

4.3 EVALUATION RESULTS

The analytical hierarchical process determined that the safety of the TSC, ability to sharpen the blades of the TSC, and the capability of the machine to cut consistent squares were the more important factors to consider when judging our concepts. Furthermore, the portability and necessity that it be human powered are not essential to the design. The weighted scoring matrix indicates that the waffle blade design best satisfies our determined criteria as weighted by the AHP, the slide slicer was a close runner-up.

Though the waffle blade presents the challenge of sharpening the unique shape of the blades, its safety and speed was rated higher than the other two designs. The waffle blade design for the t-shirt cutter is also easiest to operate as the user will only have to crank a handle to achieve both the vertical and horizontal cuts. Based on these results we have selected the waffle blade design for the T-shirt² Cutter.

4.4 ENGINEERING MODELS/RELATIONSHIPS

Model 1: Force Applied at Handle

Equation 1 models the minimum force, F , that will need to be applied to a crank in order to drive the cutting mechanism and overcome the resistive torque, T_{cut} , that occurs at the cutting blades as a function of crank handle length, l , and gear ratio, R .

$$F = \frac{T_{cut}}{Rl} \quad \text{eq. 1}$$

Equation 1 will allow us to determine a proper gearing ratio or handle length based on the maximum force we can expect our customer to be willing to exert. Currently we are not sure what the resistive cutting torque will be, but this model will allow us to make changes if its value is larger than expected.

Model 2: Blade Geometry

We have chosen to continue with the waffle blade design and certain geometric considerations need to take place to ensure that our shirts are cut with the desired dimensions. Equation 2 predicts the required circular blade diameter, d , as a function of blade spacing, s , and the number of straight perpendicular blades, N , such that the resulting cut will be square.

$$d = \frac{sN}{\pi} \quad \text{eq. 2}$$

Equation 2 will allow us to select a blade diameter based on the desired width of our shirt squares, s . It will also allow us to select the number of straight perpendicular blades if we desire a larger or smaller blade radius.

Model 3: Critical speed of the shaft

Using the Rayleigh-Ritz Method, we can calculate the critical speed of our blade and shaft configuration. Equation 3 was used to calculate the critical frequency [2].

$$\omega_c = \frac{60}{2\pi} \sqrt{\frac{g \sum_{i=1}^n w_i \delta_i}{\sum_{i=1}^n w_i \delta_i^2}} \quad \text{eq. 3}$$

where ω_c is the resonant frequency of the shaft [rpm], g is gravity [m/s^2], w_i is the weight at point i , and δ_i is the static deflection at point i . The deflection of the shaft for a uniform load is given by equation 4 below

$$\delta = \frac{wx}{24EI} (L^3 - 2Lx^2 + x^3) \quad \text{eq. 4}$$

where L is the length [m], I is the moment of inertia [m^4], and w is the weight [kg]. At the center of the rod, there will be a deflection of 0.004 mm. Applying the Rayleigh-Ritz equation we found the shaft will have a critical speed of 473 rpm. The dimensions used for these calculations are shown in Fig. 16.

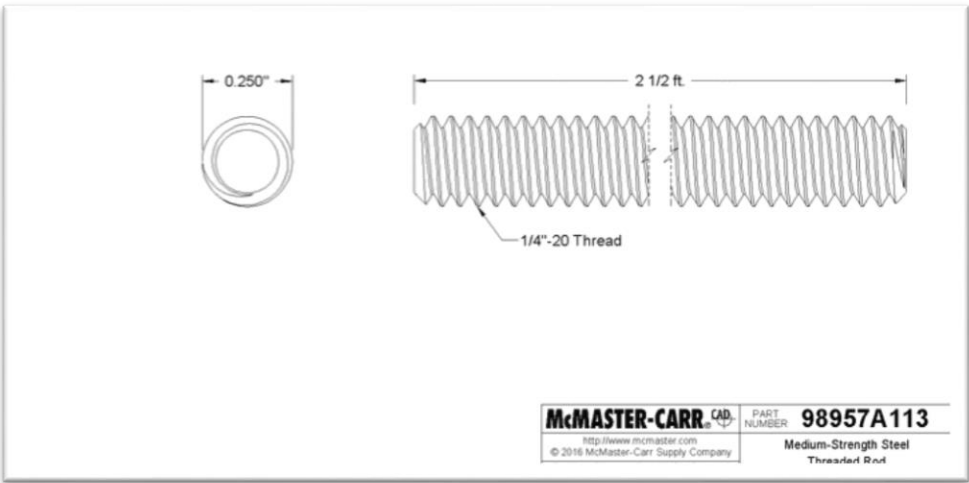

Figure 16 Dimensions of threaded rod

5 CONCEPT EMBODIMENT

5.1 INITIAL EMBODIMENT

5.1.1 Embodiment Drawings

Figure 17 below shows the T-shirt cutter embodiment assembly with the four basic computer aided design views: a front, top, side, and isometric view of the assembly. The basic dimensions of the entire machine are labeled in this drawing.

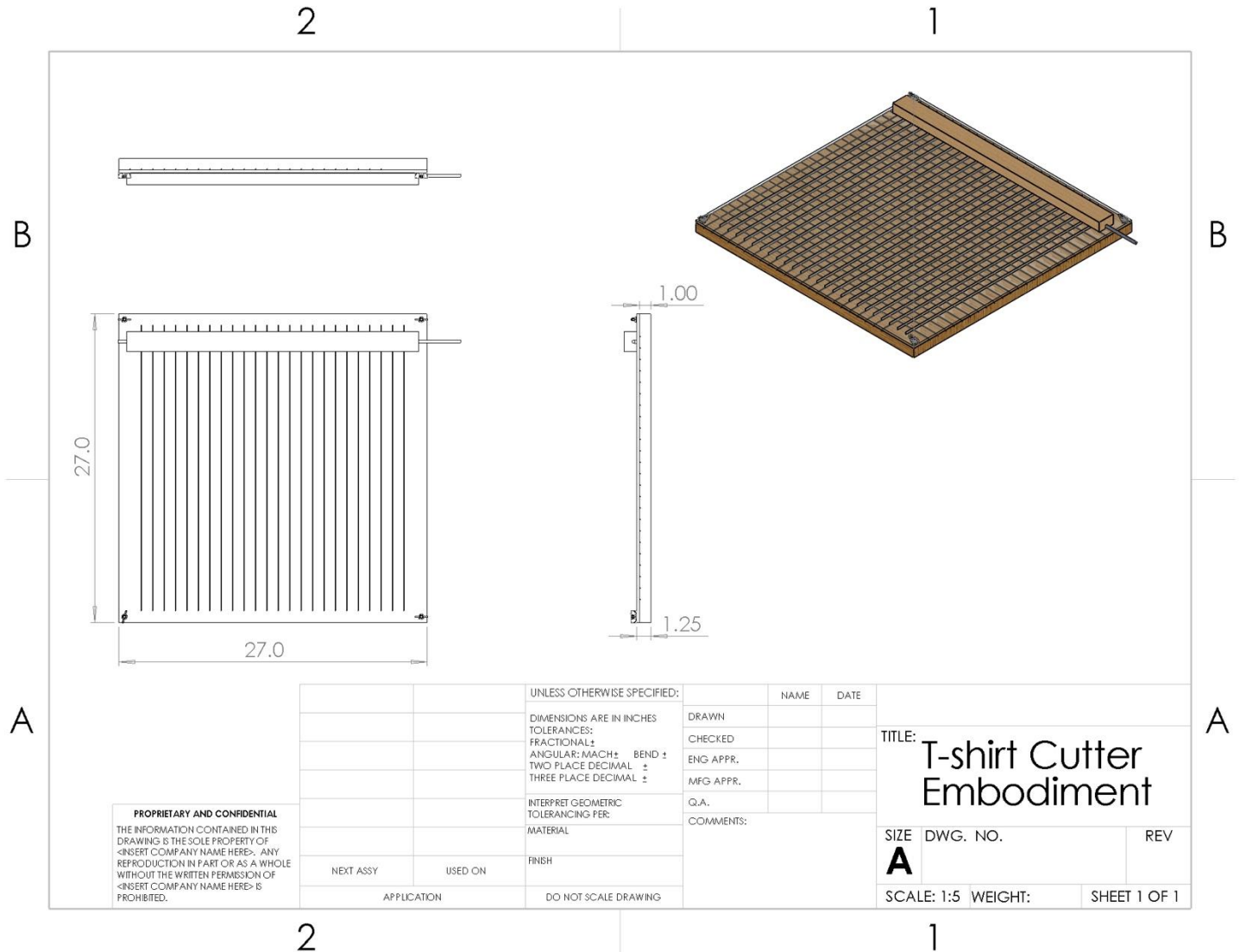

Figure 17 Basic views of the T-shirt cutter embodiment assembly in SolidWorks

Figure 18 below shows the exploded view of our model for the T-shirt square cutter with a complete bill of materials. This bill of materials from the SolidWorks assembly will be used to inspire our parts-list and purchasing for our proof of concept prototype.

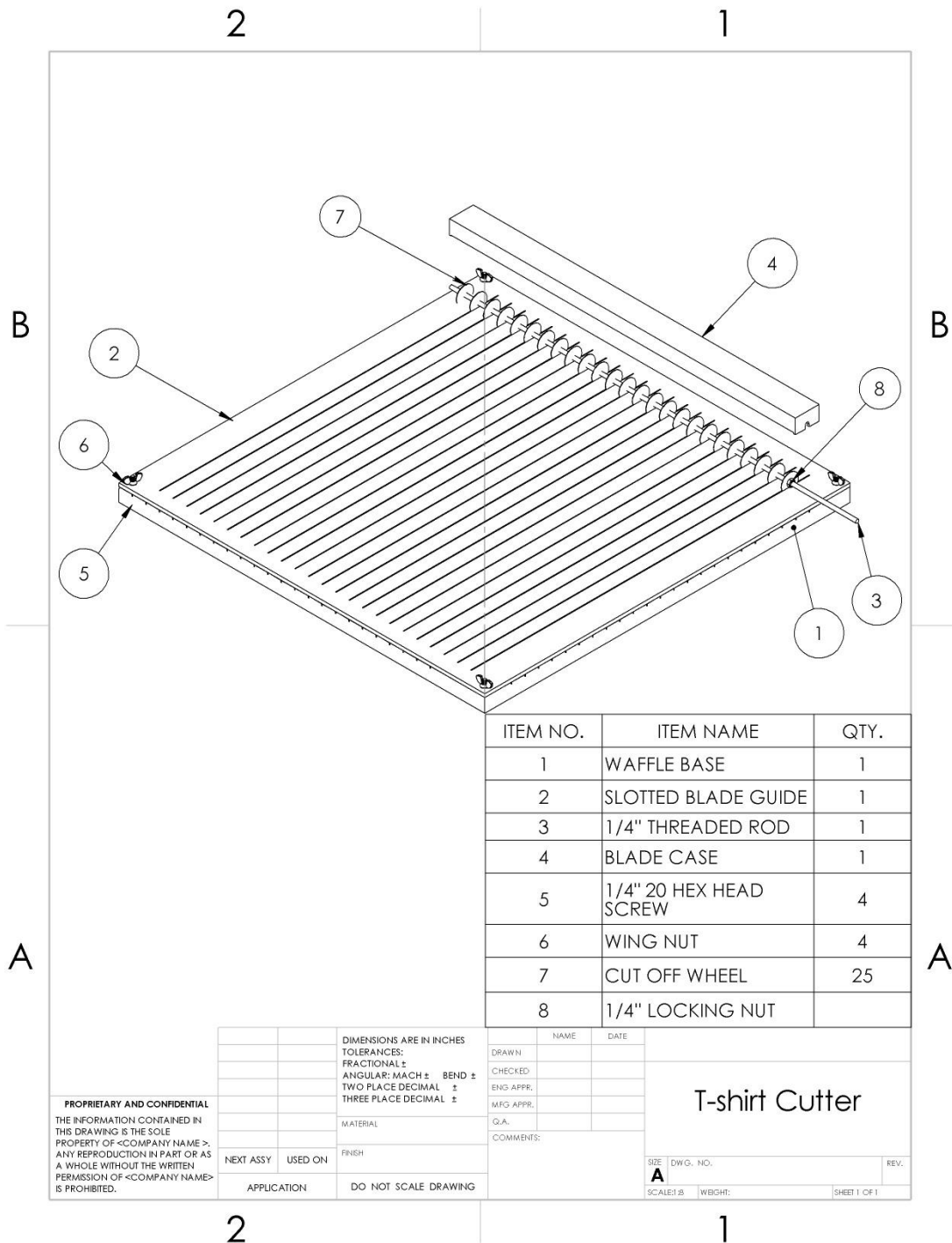

Figure 18 Assembly drawing with Bill of Materials

Figure 19 shows an exploded view of the T-shirt cutter assembly.

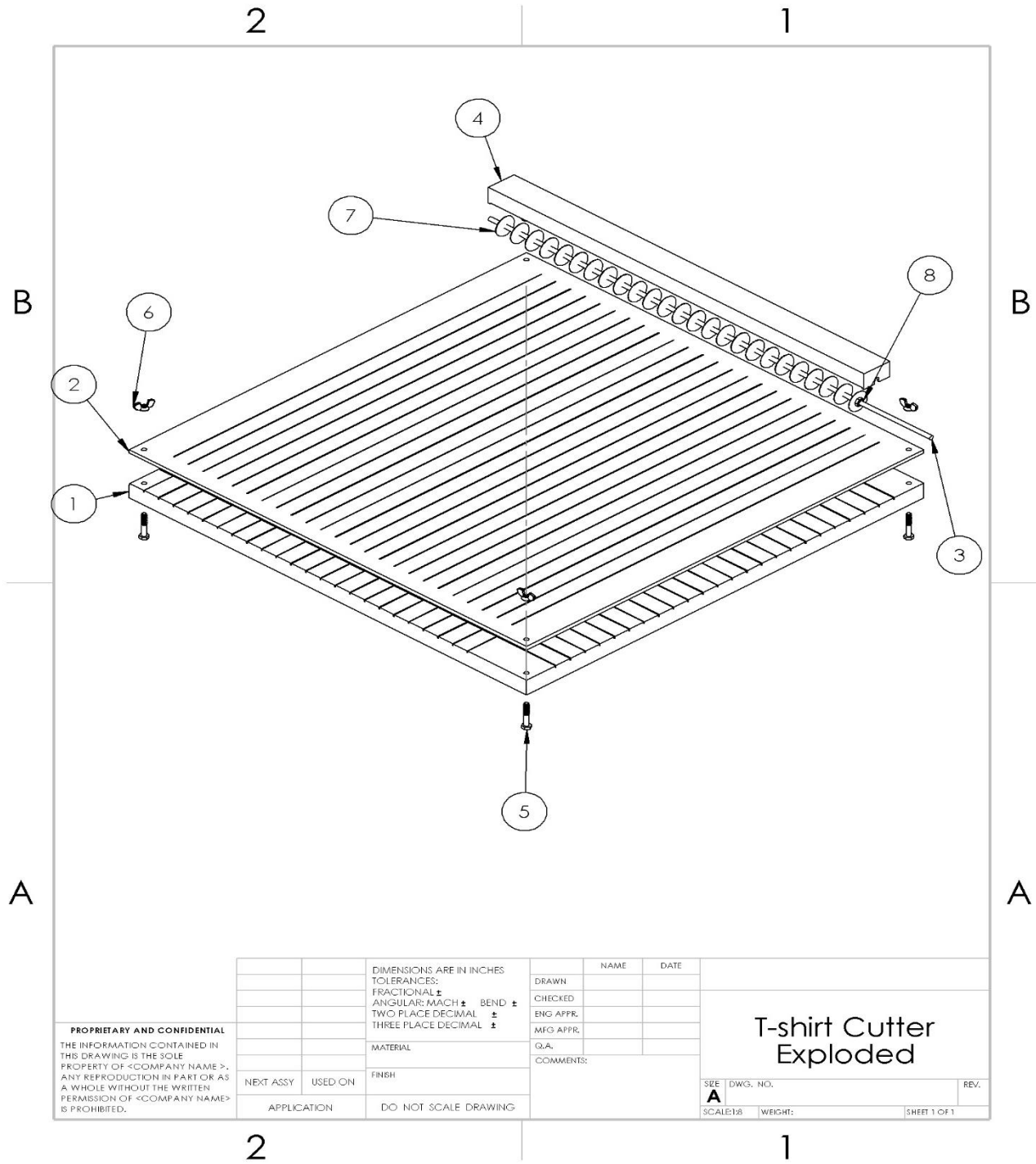

Figure 19 Exploded view of assembly

Figure 20 shows a detailed drawing of the case which will house the rod and blade configuration. This additional view was chosen because it is one of the more intricate parts.

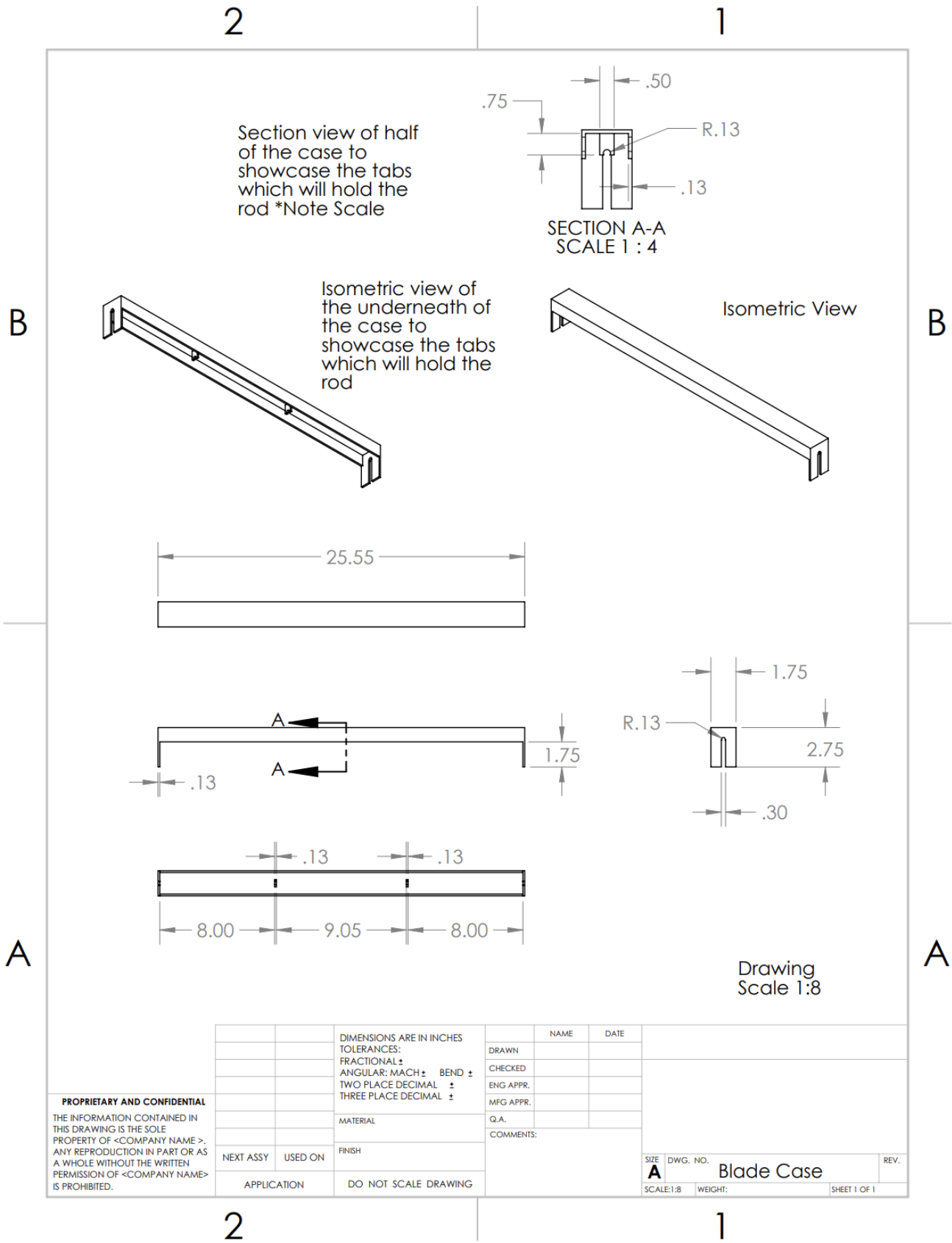

Figure 20 SolidWorks drawing of protective blade case

Table 6 shows the initial parts list of materials ordered or purchased to build the PoC prototype. The list was derived from the SolidWorks assembly shown above.

Table 6 Initial parts list of prototype components

	Part	Source Link	Supplier Part Number	Color, TPI, other part IDs	Unit price	Quantity	Total price
1	Thin locking nut	McMaster	90566A029	100 pack	\$3.71	1	\$3.71
2	2 1/2" threaded rod	McMaster	98957A113	Steel	\$2.59	4	\$10.36
3	1 1/4" Dremel blade	Amazon	RFW28100	100 pack	\$10.19	1	\$10.19
5	Dremel	Ebay	2305	1-amp blue w/flex shaft	\$29.79	1	\$29.79
6	Wood	Home Depot	431178	4 ft x 8 ft x 7/32"	\$13.98	1	\$13.98
7	wing nuts	Home Depot	215175	4 pack	\$1.18	2	\$2.36
8	hex screws	Home Depot	506397	25-box	\$10.25	1	\$10.25
Total:							\$80.64

5.2 PROOF-OF-CONCEPT

5.2.1 Prototype Performance Goals

In order to ensure that our proof of concept prototype (PoC) is on track to achieve its functionality, the following three performance goals were agreed upon. This list was approved by Dr. Potter, a Mechanical Engineering Design professor and project consultant.

1. The PoC will be able to cut at least 20 shirts without dulling.
2. The PoC will be able to cut T-shirts at least 20 times faster than it would take to do so by hand over a five-minute period.
3. Throughout a five-minute run period, the system will require less than ten-seconds of debugging.

The above list will provide a baseline metric for the T-Shirt² Cutter team to gauge the performance of the prototype with realistic and qualitative goals derived from the user needs. Although this list was created for the PoC, it is a goal of the T-Shirt² Cutter team for all prototypes to meet at least these three requirements of functionality.

5.2.2 Design Rationale for PoC Components

Selection of motor and case design:

In a previous model we calculated that at the center of the threaded rod there will be a deflection of 0.004 mm and a critical speed of 473 rpm. To avoid the shaft shifting into resonance, a motor speed was selected more than 20% away from this value. The following equation gives the minimum requirement for motor speed

$$\omega_n = (473)(1.2) = 576.6 \text{ rpm}$$

The speed of our motor must therefore be greater than 576.6 rpm. We have chosen to use a Dremel style rotary cutting tool to act as the motor driving our blades. Rotary cutting tools operate between 5,000 and 30,000 rpm so resonance in our

shaft will not be an issue. We can also further eliminate shaft wobble and resonance by adding supports to the blade shaft inside the protective case.

Determining maximum cutting torque:

The shirts being cut will exert a torque on the blade shaft. Because the motor driving the shaft has finite power, we will be limited in the amount of cutting torque our blades can exert. The relationship between motor power, speed, and torque is shown in equation 5.

$$T_{cut} = \frac{P_{motor}}{\omega} \quad \text{eq. 5}$$

$$\frac{120 \text{ W}}{1047 \text{ rad/s}} = 0.115 \text{ Nm}$$

Our rotary cutting tool motor was chosen because it has a rated power of 120 Watts, and assuming we operate the motor at a speed of 10,000rpm (1047 rad/sec), our maximum cutting torque will be 0.115 Nm. To avoid exceeding this torque, we will potentially need to limit the number of shirts being cut at one time.

Current PoC Photo

The PoC Prototype is shown in Fig. 21, in use and disassembled with the produced squares from our successful run. This PoC proves that the design will work after being adjusted and will produce perfect squares.



Figure 21 PoC prototype in use and after producing squares.

6 WORKING PROTOTYPE

6.1 OVERVIEW

For the Proof of Concept prototype (PoC), the group did not spend much time on the intricate designs that were shown in the working prototype. This attention to detail and care in precision was, in fact, the only change in between our PoC and prototype. In the PoC, we tried to cut a T-shirt with the blade array and case atop only a flat board of MDF, and guided by a poorly made guide with a dynamic width in the slots. The guide and MDF board were held together by a combination of clamps and human aide during operation. The combination of having no slots in the MDF base board, and the narrowing slots of the top cutting guide led to a large amount of interference between the blades and wood. This ultimately burnt out our motor. The prototype remedied this problem almost entirely. To fix the bottom interference, the team created a waffle base, which is a square plywood base with 20 1/8" deep slots cut evenly spaced along the base, and another 20 1/8" deep slots cut perpendicular to those, to account for cutting in both directions. To fix the interference with the slotted guide, another guide was created, this one was meticulously measured and constructed, ensuring that each panel of the guide was parallel and straight, and the tolerance was widened to give the blades more space to go through. The bottom of the slotted guide was also painted with Plasti-Dip coating to increase the friction between the T-shirts and the case. This prevents the T-shirts from getting caught in the blade after slipping out of position. The blade guide and the waffle base are not held together by long bolts and wing nuts, allowing for a faster rotation of the top plate and alleviate the need to have clamps or a person holding them together. Overall, these fixed worked well and the team was able to increase the number of squares by a factor of 10.

6.2 DEMONSTRATION DOCUMENTATION

Figures 22, 23, 24 and 25 show the working prototype. Figure 26 shows the squares cut by the prototype.

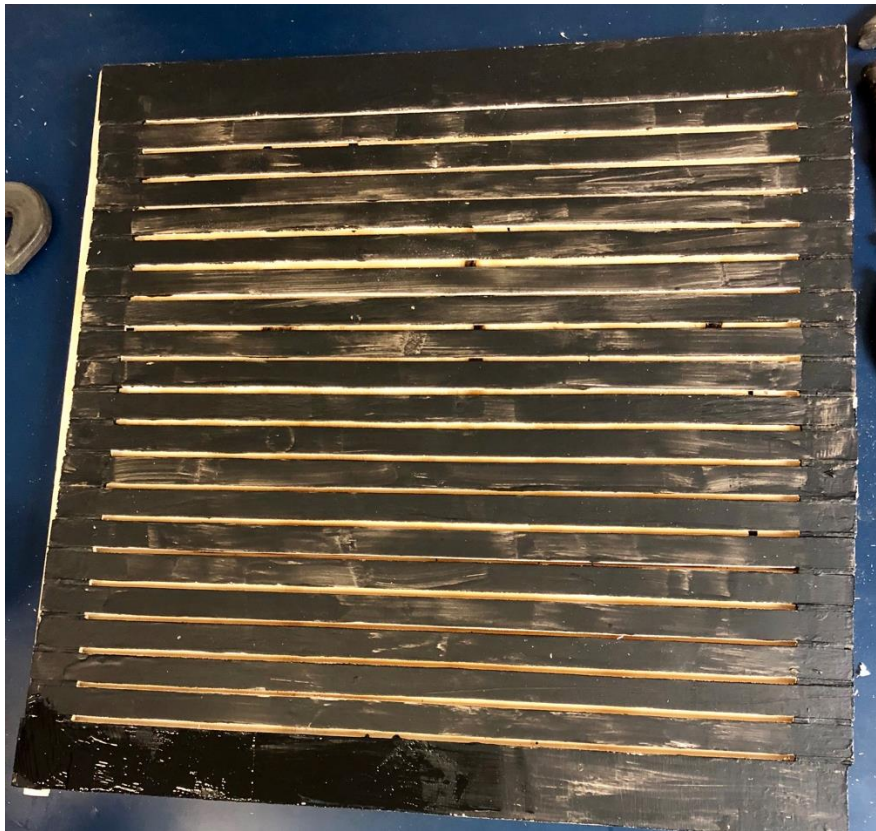

Figure 22 The slotted guide for the blade array painted with Plasti-Dip to keep the T-shirts in place

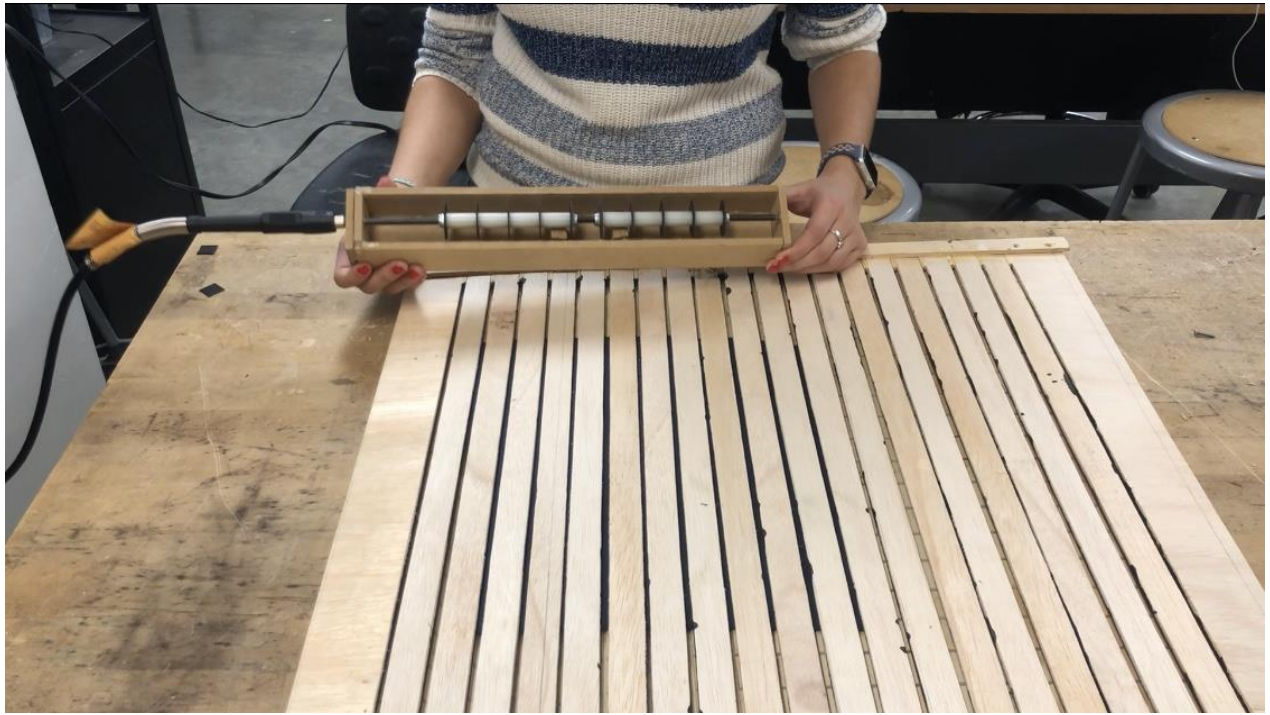

Figure 23 A motor test with the blade array prior to operation

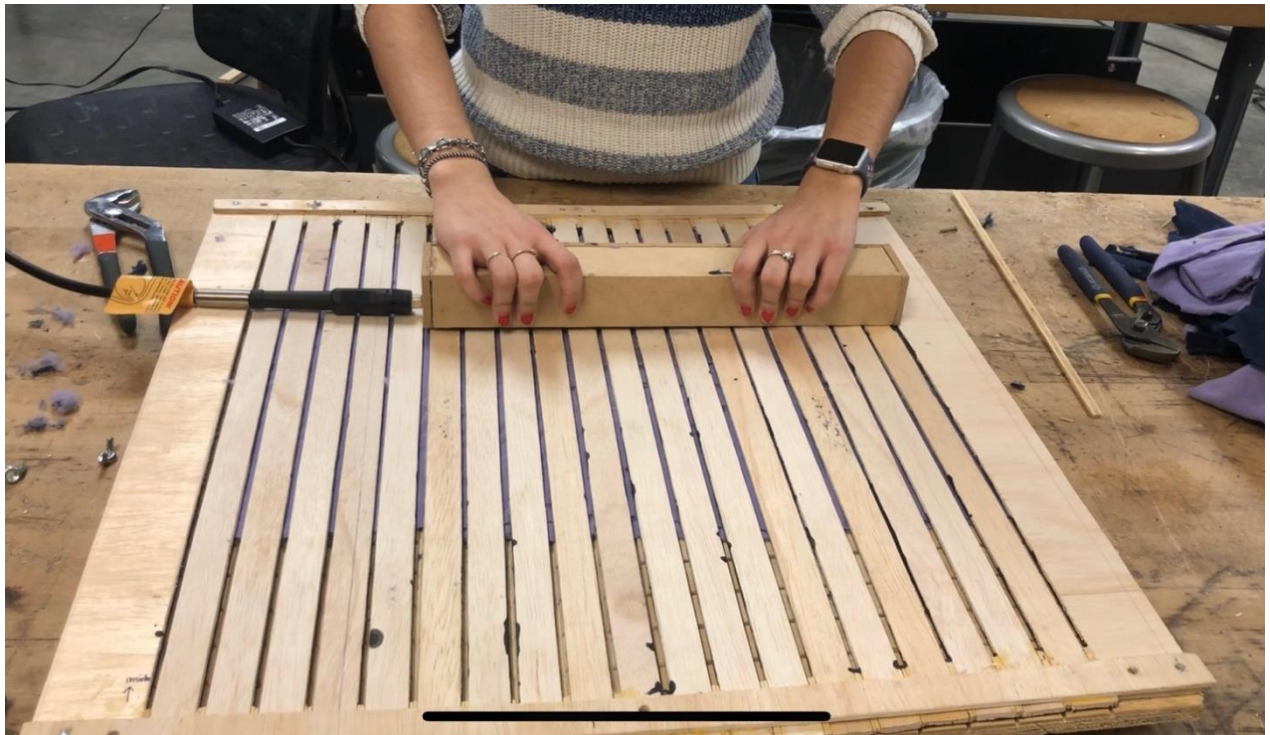

Figure 24 The T-shirt² Cutter in use with a purple shirt in between the waffle base and the slotted guide

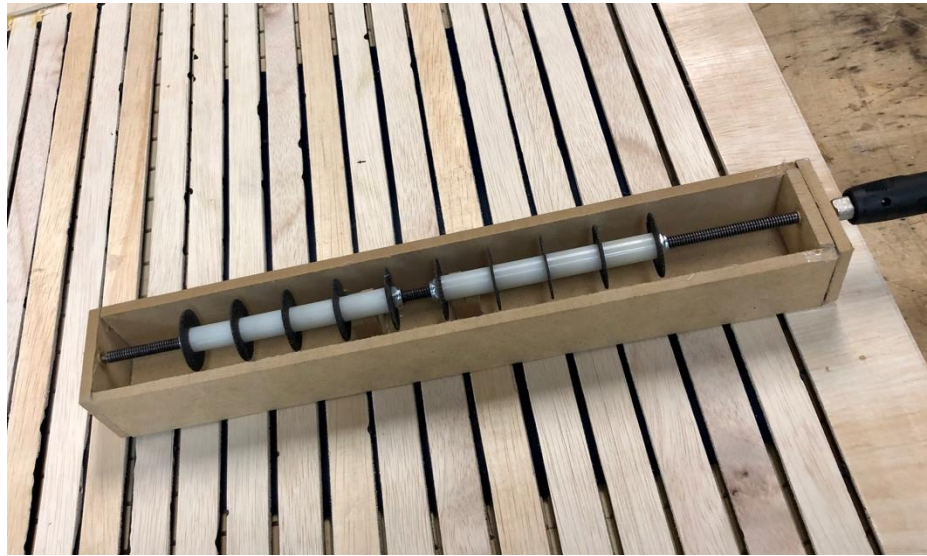

Figure 25 The blade array inside the blade case, resting atop the slotted guide



Figure 26 The first two squares cut by the T-shirt² Cutter PoC compared to the 20 squares cut by the working prototype.

6.3 EXPERIMENTAL RESULTS

The T-shirt² Cutter had three design requirements to evaluate how well it was meeting user needs in the working prototype stage. Below are evaluations of the success of the prototype meeting each goal.

- 1) *Cut at least 20 shirts without dulling.* Originally, the only way assumed to cut the cloth of a T-shirt was to use a sharp blade tool like scissors. A major problem with needing to cut cloth with a sharp tool is how quickly the blades dull, rendering them unable to perform the necessary task. However, this particular design and user need has since been entirely achieved due to design of the T-shirt² Cutter. The T-shirt² Cutter has been designed to use cutoff

blades which cut using abrasion rather than with a sharp edge. This makes the need to sharpen the blades obsolete. As such, this requirement was not tested during the prototype demo.

- 2) *Cut at least 20 times faster than by hand over a five-minute period.* During the prototype demo it took our team 5 minutes to cut one T-shirt into squares. Using scissors, it takes a practiced T-shirt cutter, Dr. Ruppert-Stroescu, 25 minutes to cut a T-shirt by hand and the average person 40 minutes, which is much longer than we originally expected. Thus, over a five-minute period we are able to cut a shirt 5 times as fast as Dr. Ruppert-Stroescu and 8 times as fast as an amateur T-shirt cutter. Therefore, we did not meet our design goal of cutting 20 times faster over a five-minute period. With improvements to the blade array and slotted guide we believe that this is still a feasible design goal, especially if we are able to cut more than one shirt during a run.
- 3) *Operation requires less than ten seconds of debugging time during a five-minute period.* During our initial prototype demo, this was a very big problem. The screws that we had were not long enough to go through both the waffle base and the blade guide and hold a wing nut, so to unscrew them, screwdrivers were sometimes necessary. That task took a lot of time. Another bug is that the fluff from the T-shirts being cut accumulated in the blade case and the operator stopped to get it out between passes of the blades over the shirts. Finally, the Dremel motor was being held by a bystander and became noticeably hot during operation. For the final iteration of the T-shirt² Cutter, the bolts will be longer so that the holes can be larger and un-threaded, making blade guide easier and quicker to take off. The motor has been upgraded to meet the working requirements better so that it will not become so hot. Finally, a can of compressed air will be included with the T-shirt² Cutter.

7 DESIGN REFINEMENT

7.1 FEM DEFLECTION ANALYSIS

To assess the possible effects of deflection on the performance and safety of the T-Shirt² Cutter, an FEM deflection analysis was conducted on one of the critical components of the device. The component chosen was the rotating blade shaft because deflecting of the quickly rotating shaft would have a severe negative impact on the performance and safety of the device.

7.1.1 Mesh, Loads, and Boundary Conditions

Using SOLIDWORKS, a medium-fine mesh was created. To simulate the real-life conditions of the blade shaft, the driven end was fixed and the free end was modeled as a hinge allowed to rotate. A torsional load was placed on each blade with the total torque being set to 0.2 Nm, and an upward force was placed on each blade with the total force being 50 N. These loads simulate the torque exerted on the shaft by the fabric being cut, and the upward force on each blade as a result of the user pressing the shaft into the fabric. Figure 27 shows the mesh, loads, and fixture at one end.

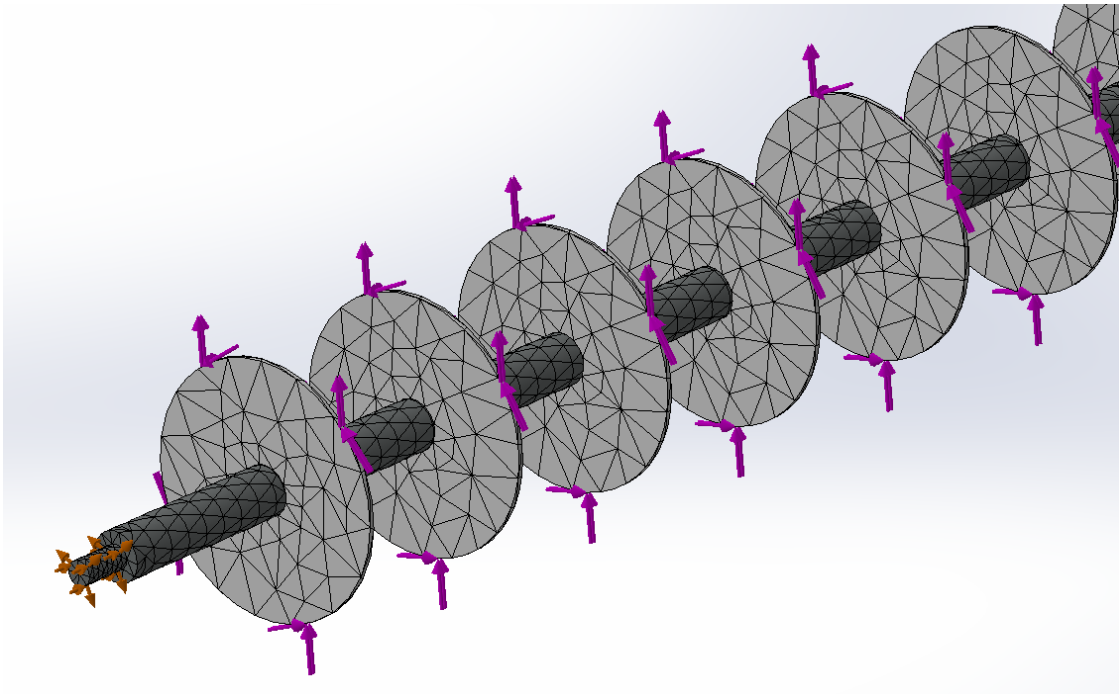

Figure 27 Mesh, loads, and fixtures of blade shaft

7.1.2 Analysis Results

Preliminary analysis results indicated that the torsional load would have minimal effects on the deflection, and therefore performance of the shaft. Figure 28 shows the results of the FEM deflection analysis due to the upward load.

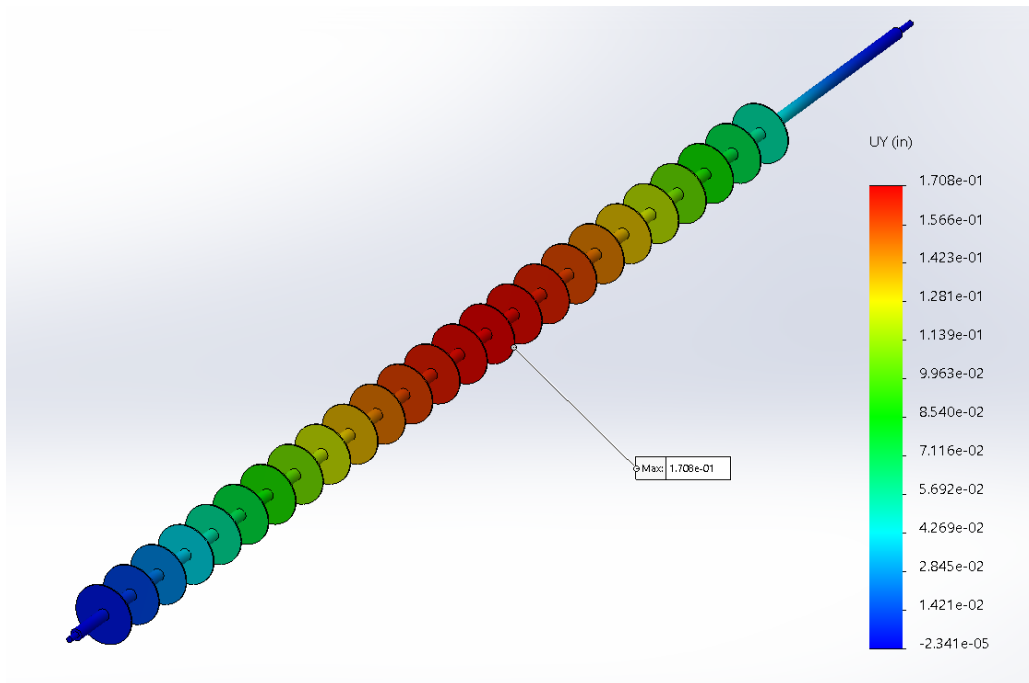

Figure 28 FEM deflection analysis results

Based on our analysis, it can be expected that the upward load on the blades will deflect the center of the shaft by approximately 0.2 in. This deflection can lead to vibrations in the shaft, which can be catastrophic if the driving motor approaches critical frequency. Based on these results, we have decided to reduce the length of the shaft by 50% and include a shaft support at its center. This will greatly reduce the shaft deflection, as the shaft is now effectively one fourth its original length. The shaft will still deflect a small amount, but its effects will be negligible.

7.2 DESIGN FOR SAFETY

7.2.1 Risk Identification

Five of the highest safety risks of the T-Shirt² Cutter are defined below.

1. *Shirt on Fire*: The frictional forces between the shirt(s) and the friction-cutting blades generate heat which could potentially cause the shirts to catch on fire especially if they are of flammable material. The current recommendation to mitigate this risk is to have a fire-extinguisher nearby, it is also recommended to only cut non-synthetic T-shirts. An issue with this solution is that the user may want to cut a synthetic and/or blended shirt and the current equipment is not suitable for this material. The team has identified the likelihood of this event occurring as “low-medium”, and the impact as “catastrophic” if it were to occur.
2. *Blade Breaks*: If one of the blades catches on a something it could break off and create shards of blade and particles the material it was caught on. This is dangerous because shards could go flying and hit someone. The current recommendation to mitigate this risk is to not use T-shirts with solid embedded decorations (buttons, rhinestones, etc.), and to always use the provided case designed to cover the blades. A problem with this solution is that the user might want to remove the protected case or forget to put it on. The team has identified the likelihood of this event occurring as “low-medium”, and the impact as “significant” if it were to occur.
3. *Exposed Blades*: With the case not attached, the blades would be exposed to the user which is bad because they could cut the user directly or get caught on items of clothing that the user is wearing. The current solution to this problem is that the blades cannot cut the t-shirt properly or be moved without the case being attached. Another recommendation is that the user not wear loose clothing or long sleeves. A note about this risk is that even though

the machine will not operate without the case, it is likely that a user will at some point forget to put it on. Another note is that clothing getting caught in the blades is likely and could be very dangerous. Taking this into account, the team has identified the likelihood of this event occurring as “medium”, and the impact as “significant” if it were to occur.

4. *Case Breaks*: If there is a failure in the structural integrity of the blade case, and the case fails during operation, the user would be at risk of falling into operating blades. The current recommendation to mitigate this risk is for the user to check the case for damage thoroughly before every operation and if the user were to hear a snap or feel the case move at all abnormally, to halt operation immediately. This failure would be extremely dangerous for the user, but a consideration is that if the user is determined to finish a cut, they may be motivated to ignore warnings. If the user were to drop the case at any point, it is likely that the cases structure would be compromised. Taking this into account, the team has identified the likelihood of this event occurring as “medium”, and the impact as “catastrophic” if it were to occur.
5. *Case Falls Off Track*: If the blades and case go off track or off angle for any reason, the machine will not cut the T-shirts. It is recommended that the user halt operation and re-align the blade case. This occurrence is very unlikely, and if it happens it would likely be a tilt of the case rather than an issue of all the running blades being exposed; most damage would be to the top plate of the device. Taking this into account, the team has identified the likelihood of this event occurring as “medium-high”, and the impact as “insignificant” if it were to occur.

7.2.2 Risk Assessment Heat Map

Figure 29 shows the risk assessment heat map of the T-Shirt² Cutter design safety risks. The map was generated with a Risk Assessment Tool in excel provided to the team by Dr. James Potter. It is based off of the risks defined in section 7.3.1 Risk Identification, where each risk is defined as a function of likelihood of occurrence and impact.

Risk Assessment Heat Map

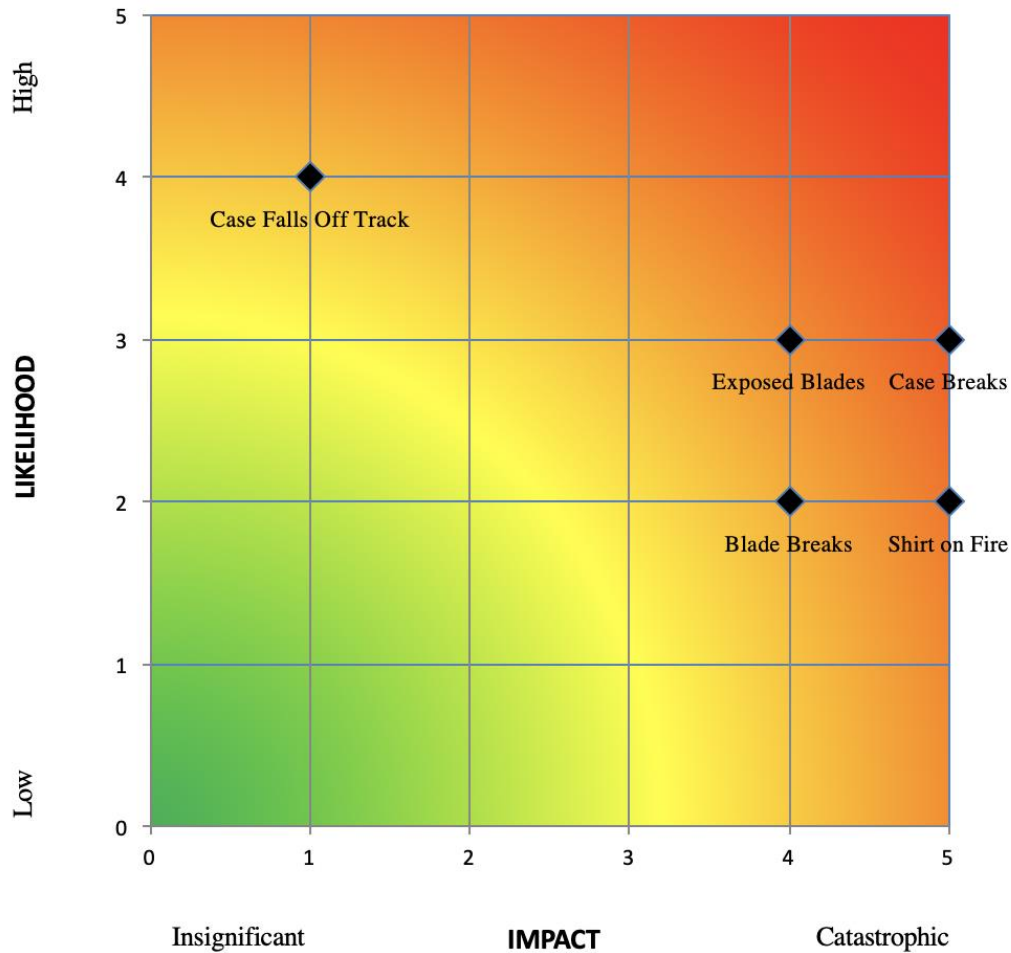

Figure 29 Risk assessment heat map

7.2.3 Prioritization of Risks Based on Risk Assessment Heat Map

From the Risk Assessment Heat Map in Fig 29, it is clear that the highest priority risk to be dealt with is the risk of the case breaking. It has the highest overall combined impact and likelihood score. The next highest priority risk from the risk calculator is the risk of exposed blades, because it is highly likely and highly impactful. The third highest risk to assess is the possibility of the shirts catching on fire while the machine is cutting them. This occurrence would be catastrophic if it were to occur, but is ranked third because it is not likely to happen. The risk of a blade breaking would be the next priority, this is because it is not likely. The lowest priority risk is the possibility of the blade and case configuration falling off of the track. The Risk Assessment Tool has reinforced the risk prioritization of the defined risks for the T-Shirt² Cutter with the results discussed above.

7.3 DESIGN FOR MANUFACTURING

Draft Analysis

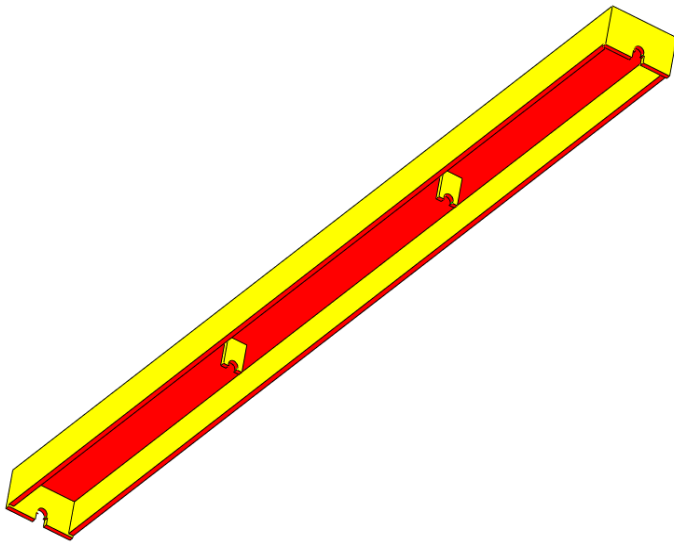

Figure 30 Original draft analysis on blade case

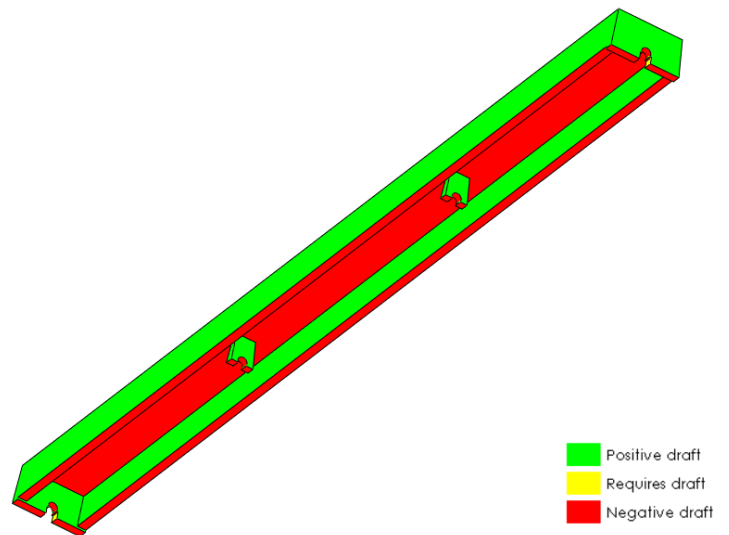

Figure 31 draft analysis on blade case with 3° draft

A draft analysis was run on the blade case. Initially, all of the vertical walls on the case required a draft, the results of this analysis are shown in Fig. 30. A 3° draft was added to each of the walls so that the wall thickness would be minimally affected. A second draft analysis showed these walls now had a positive draft and no other walls required draft, this is shown in Fig. 31. The results of this analysis indicate the blade case could be manufactured by injection molding.

DFM Analysis

A DFMPress Analysis was run on the waffle base of the T-shirt Square Cutter. Below are the results for an analysis run for a mill/drill only and an injection molding manufacturing method.

Mill/Drill only

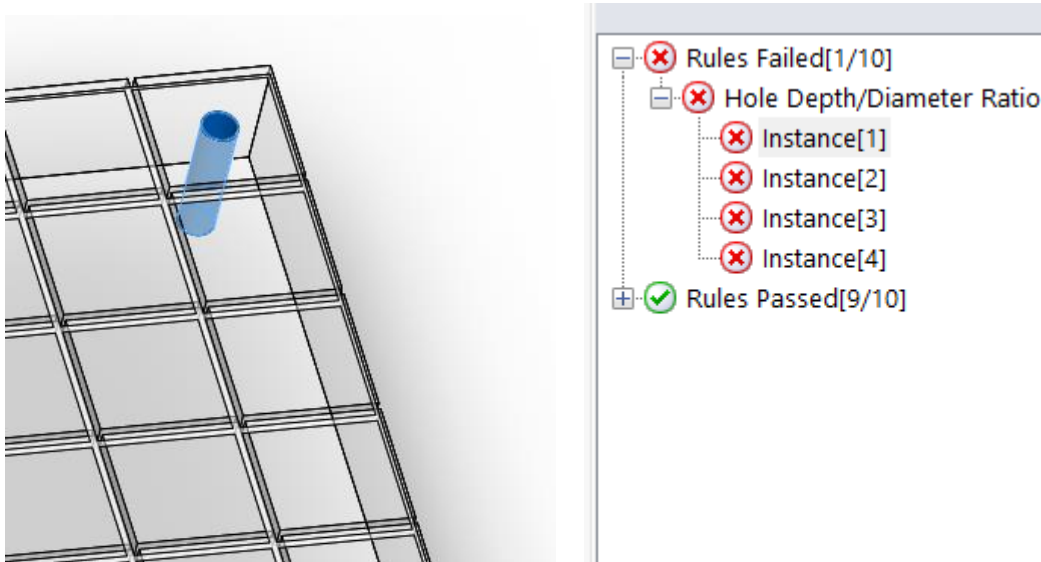

Figure 32 Issues present for a mill/drill only manufacturing process

This part would have four issues, shown in Fig. 32, present if it was to be manufactured using a mill/drill only process. These issues were at the corners of the waffle base where there are holes cut for the bolts that will fasten the base to the slotted guide. The error message for these issues said the “depth to diameter ratio is 4 whereas the recommended ratio is

2.75.” If we were to manufacture this with a mill, we could fix this issue by making our holes larger or using a different method, like a drill press, to cut the holes.

Injection Molding

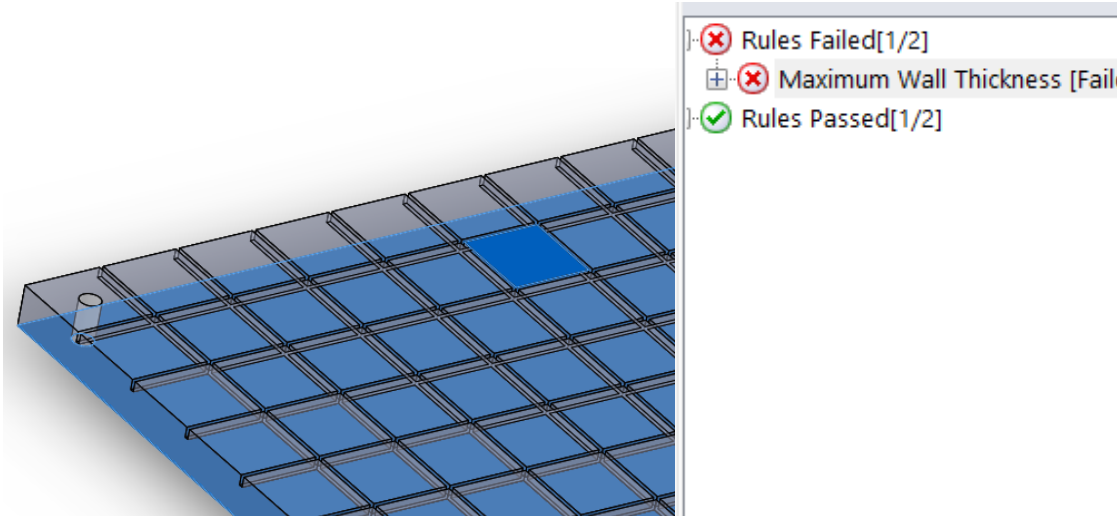

Figure 33 Issues for an injection molding manufacturing process

This entire part is too thick to be manufactured by injection molding. Figure 33 shows just one instance of the part failing the wall thickness criteria. Because this part has so many walls made from the slots cut in it, there were 572 instances where the wall thickness criteria was not met. The error message instructed that we should “avoid walls which are too thick to prevent cooling and defects such as sink marks and internal voids.” If this part was to be manufactured by injection molding, we would have to decrease the thickness of the entire part, which might affect its sturdiness.

7.4 DESIGN FOR USABILITY

The following physical impairments of a user were taken into consideration after the design of the T-Shirt² Cutter, and the team’s assessments of usability and considerations for future improvements to make the design more accessible are listed below:

1. *Vision:* This device will still be operable by someone with a vision impairment. Some precision is required to fit the blades into the slotted t-shirt overlay however there will be grooves that the blade case will fit into that will make this fit easy for the user. Additionally, the motor is clearly marked with on/off buttons and speed settings for the user to read.
2. *Hearing:* If the motor is stalled the user will hear that the blades are not spinning and should turn the motor off immediately. When the motor running normally it is quite loud so even a user who has trouble hearing should if the motor has stalled. If the user cannot hear the motor or lack thereof, the case vibrates when the blades are running normally and this should signal to the user that the motor has stalled.
3. *Physical:* Depending on the severity of the user's physical impairment, it is possible for the device to be operated by someone with a physical impairment. There are minimal variables associated with risk in physical control as a majority of the motions required are guided with slots or tolerances in the device itself, and much of the danger is encased. The motions required to set up the device will be the most limiting as wing nuts are used to compress the shirts and they require a high level of motor skill and precision to install. In the future, it would be a good idea to have the shirt compression be automated in some way or only require one motion as opposed to requiring four wing nuts to be installed.

4. *Language*: Language should not be any barrier to the user after they learn to use the device. The instructions provided will be in English. As such, a translator will be necessary at first, but after that there is no additional language requirement of the device because the operation does not require speaking or reading. In the future it would be beneficial to other language speakers for us to provide instructions in other languages.
5. *Control*: There is a risk of excessive fatigue and distraction in this device as it requires a high frequency of repetitive motion. There is a possibility of wrist fatigue from applying force to move the blade case across the T-Shirts. However, the distraction problem is low, as the operation requires a lot of dynamic motion (changing the orientation of the top plate, installing the wing nuts, turning the motor on and off, etc.).

8 DISCUSSION

8.1 PROJECT DEVELOPMENT AND EVOLUTION

8.1.1 Does the final project result align with its initial project description?

Yes, the final product does fit the initial project description. Dr. Ruppert-Stroescu is a fashion design professor at Washington University, she has developed a method of upcycling old T-shirts by cutting them into strips or squares and weaving them together to create one-of-a-kind clothing items. Her current method to cut the squares was with fabric scissors, which can take upwards of 20 minutes just to cut a single shirt. To speed up this portion of the process, Dr. Ruppert-Stroescu wanted a tool that would cut T-shirts into squares. The final result of this project is able to cut shirts at an increased speed so she will be able to spend less time cutting shirts and more time creating patterns and weaving T-shirts together. Additionally, our machine requires little manual effort from the user as outlined by the project description. It is safe, portable, and easy to use so Dr. Ruppert-Stroescu or one of her students will be able to operate the machine as needed.

8.1.2 Was the project more or less difficult than expected?

Overall, the project was more difficult than expected. When selecting this project, we didn't consider the difficulties associated with having blades in our product. Initially, when we were considering using steel blades, we were having trouble creating a design that would be safe, have an integrated sharpener, and was easy to manufacture. The use of carbon-fiber blades allowed us much more flexibility with the design because they are totally safe while the motor isn't running and don't dull. Cutting squares rather than just strips also proved to be difficult. Cutting fabric requires that the fabric be held taught so the blades are able to shear through it, this is even harder to achieve after the initial strips are cut so we had to manufacture parts that would hold the shirts in position during the process. Furthermore, manufacturing difficulties arose when a fire in the digital fabrication lab put the laser cutters out of service for the semester. Since we were planning to laser cut the slotted base guide, we had to think of a work around, which required us to glue over 40 pieces of wood together, resulting in slots that were not as evenly spaced as they could have been if laser cut.

8.1.3 On which part(s) of the design process should your group have spent more time? Which parts required less time?

During the design process we should have spent more time on our proof-of-concept prototype. Though we knew the final product would have a slotted base we neglected to add slots to the base because of time constraints. Having slots in the base would have given us an accurate idea of the depth needed for the slots to be effective. We also had issues with the shirts getting caught in the blades, something that could have been alleviated with a slotted base. The broken laser cutter caused us to have a last-minute change in the manufacturing of the slotted guide, leading to slots that were unevenly spaced. These unevenly spaced slots cause a lot of rubbing between the guide and the blades. During the proof-of-concept runs our motor continued to stall and because there were several possible issues, it was impossible to pinpoint exactly what was causing the stalled motor so that we could fix the problem.

The working prototype required less time than expected because we did not have to make a new blade array and only had to manufacture the blade guide and the slotted base. Additionally, the blade array took less time to make in general especially when nylon spacers were used for construction instead of locking nuts.

8.1.4 Was there a component of the prototype that was significantly easier or harder to make/assemble than expected?

The blade array design initially held the blades in place with locking nuts that required a lot of time and effort to screw into the right spot on the threaded rod. When we switched to nylon spacers instead, it became very easy to slide them on the rod with blades in-between. What we initially expected would be the hardest part to assemble was actually the easiest, at least for the later iterations of the blade array.

The waffle base was harder to make than expected because it was difficult to cut straight lines with the circular saw and it was extremely important that the slots on the waffle base be straight. A lot of time was spent lining up guides for the circular saw so we could ensure the slots were straight, one inch apart, and parallel. Because of laser cutter complications,

the slotted guide was significantly more difficult to manufacture. What would have taken minutes with a laser cutter became hours of cutting and gluing. With the tools available in the studio, it was difficult to cut pieces of wood that were exact to our desired dimensions. Gluing and clamping the 60 pieces of wood together was also very hard to do without breaking the part.

8.1.5 In hindsight, was there another design concept that might have been more successful than the chosen concept?

The design concept that we initially chose is vastly different from the design we actually manufactured. Our chosen design concept used a “waffle” blade to cut the shirts into squares. This waffle blade would have had circular blades as well as straight blades that would have cut squares in single pass. As we began the process of purchasing parts so we could begin to manufacture the concept, it became apparent the design would be much too hard to manufacture. Early-on we changed our chosen design to be what it is now: the waffle base, slotted guide, and blade array of cut-off wheels. I think this design concept is more successful than the waffle blade concept would have been. The waffle blade would have been extremely difficult to safely sharpen and may not have had the force necessary to shear through the T-shirt fabric.

Our final design for the square cutter is most like the slide slicer design concept from Fig. 14 however we do not think this would be more successful than the final chosen concept (waffle base and slotted guide). None of our initial design concepts used a motor, which we feel is essential to cutting quickly through the T-shirt fabric.

8.2 DESIGN RESOURCES

8.2.1 How did your group decide which codes and standards were most relevant? Did they influence your design concepts?

We knew our project would be dealing with the cutting of T-shirts so we decided to look into codes and standards related to cutting and textiles. Codes and standards relating to the clothing and textile industries, since we were working with T-shirts, were particularly of interest to us. Codes and standards relating to textile machinery in general provide useful information on safety requirements, noise codes, and frequently occurring hazards that are common with certain machine elements. We were specifically interested in the safety requirements for textile machinery which includes assembly and maintaining of textile machines and hazards that arise from certain textile cutting devices.

These codes and standards ultimately did not influence our design concepts. Because cutting T-shirts is relatively free of hazards we mainly focused on ensuring whatever blades we included in our design would not be able to harm the user, whether the machine was in operation or not.

8.2.2 Was your group missing any critical information when it generated and evaluated concepts?

Though it would have been impossible to know at the time, when we were in the concept generation phase it would have been useful to know that we would not have access to a laser cutter for the duration of the semester. Because choosing a design that was manufacturable was key, it would have been immensely helpful and we could have potentially selected a design that did not require a laser cutter for certain pieces. During this time we also lacked critical information on certain aspects of cutting T-shirts that would have been helpful for us to generate realistic design concepts. Because of other widely available fabric cutters that we researched, we assumed that our design would need to have sharp blades to cut the shirts. We did not consider the idea of motorizing a duller set of blades, which would eliminate the need for a sharpening feature. We also did not know that T-shirts getting caught in the blades would be a problem which could have changed the way we designed and evaluated our team’s concepts. Finally, it would have been useful to know the complexity of creating a machine that can both hold fabric down, as well as cut fabric in two directions.

8.2.3 Were there additional engineering analyses that could have helped guide your design?

If given more time, we would like to perform stress analyses on more aspects of the blade case. Specifically, we believe that there is an optimal blade array and blade case design that could be found. We know that with our original design, the deflection of the blades was too large to cut properly. To remedy this, our final iteration is half of the size we initially wanted the blade array to be. Although we think that that design change will solve the deflection problem, we believe that

more deflection analysis on the blade array inside the case would allow us to find an optimal size for the array making tabs inside the blade case unnecessary for the design to work properly. Additionally, the tabs inside the blade case were created at an arbitrarily thick thickness to ensure that they would not break under the load from stopping the deflection of the blade array. With an analysis of the deflection in the rod and the load on the tabs, we could determine the optimal thickness for those. This would be an important improvement as the current tabs are interfering with the plastic spacers on the blade array rod, causing friction and removing material from the spacers. Ideally, we would like to find an optimal length of the rod and blade case configuration to allow us to not need tabs and to avoid that interference between the tabs entirely.

8.2.4 If you were able to redo the course, what would you have done differently the second time around?

If our group was to redo this course a second time, we would have spent a lot more time on the design concept generation. Many of our issues with working together as a team, and communicating about design prior to completing the PoC could have been avoided by the team as a whole putting more effort into the design and ensuring that each member had a clear picture of the design and were all on board with the design. If we had spent more time looking into different design configurations to complete our goals, there would have probably been more commitment from all members to the design. These problems all went away once we had a working PoC, and we had a solid, working direction to our design. Focusing on a concept in the beginning would have allowed us to spend more time on each following design aspect. If this were to be done a second time, we would also like to find access to a laser cutter or perhaps outsource the precise cutting of an acrylic or other dense material for the blade guide and the waffle base. Our project would have been significantly better designed and looking in the final version if we had access to tools that could cut materials other than wood and metal precisely.

8.2.5 Given more time and money, what upgrades could be made to the working prototype?

We do plan on continuing this project in the future so that all of our design goals are met. Given more time, we would redo a few of the parts and use additional money to upgrade some of the materials that are currently used in the machine. A more rigid shaft would reduce the deflection of the blade array so that the shirts are more evenly cut. We might also opt to cut the squares with sharp blades rather than abrasion, this would require that we integrate a blade sharpening tool however the shirts will be more evenly and consistently cut. A thinner slotted guide, made from acrylic or a similar material, and larger blades would make it possible to cut several layers of T-shirts, speeding up the process significantly. All of these changes would be possible with a larger budget to purchase materials, additional time would allow our team to test several ideas to determine which is best.

8.3 TEAM ORGANIZATION

8.3.1 Were team members' skills complementary? Are there additional skills that would have benefitted this project?

Team members' skills were complementary. All members excelled in brainstorming ideas and thinking ahead about potential problems that could occur. Sophie was conscious about designing for ease of manufacturing and ensuring that any design changes were feasible in the given time. Avery was familiar with a lot of the tools we were using to construct parts so he was the go-to person for questions about building. Avery's electrical background also gave him the knowledge needed to select the correct motor for our design. Taylor, having taken the machine shop practicum, was great at using the tools in the machine shop and was also very safety-conscious. Additionally, Taylor was excellent at keeping the team on a schedule and ensuring that any deliverables were good quality submitted on time. Between Sophie's stellar work ethic, Avery's knowledge of power tools, and Taylor's leadership and knowledge of power tool safety, all of the necessary skills for this project were covered.

8.3.2 Does this design experience inspire your group to attempt other design projects? If so, what type of projects?

Sophie knew her strength did not lie in design projects because she does not particularly like using power tools and also struggles to conceptualize solutions to problems. However, the success of the T-shirt cutter has encouraged her to potentially work on a design project in the future if it appeals to her interests. Avery enjoys building and fixing things, and working through difficult problems. Throughout this project he gained a lot of insight into the design process, and while

it's not as glamorous as previously perceived, Avery is eager to work on future design projects. Some future projects for Avery would likely be related to the automotive field where many of his interests lie. Taylor knew going into this project that she loved to design and build machines that provided useful solutions to any kind of real-world project. However, she was unaware of the widespread applications of useful machine applications, which we now know include the fashion industry. This project has inspired her to want to work on more projects in unconventional design fields in the future.

APPENDIX A – COST ACCOUNTING WORKSHEET

Table A-1 Cost accounting worksheet

	Part	Source Link	Supplier Part Number	Color, TPI, other part IDs	Unit price	Quantity	Total price
1	Thin locking nut	McMaster	90566A029	100 pack	\$3.71	1	\$3.71
2	2 1/2" threaded rod	McMaster	98957A113	Steel	\$2.59	4	\$10.36
3	1 1/4" Dremel blade	Amazon	RFW28100	100 pack	\$10.19	1	\$10.19
5	WEN Rotary Cutting Tool	Ebay	2305	1-amp blue w/ flex shaft	\$29.79	1	\$29.79
6	MDF	Home Depot	99167229638	2ft x 2ft	\$3.26	2	\$6.52
7	wing nuts	Home Depot	887480023718	4 pack	\$1.18	2	\$2.36
8	Carriage Bolt	Home Depot	204633611	1/4 x 1	\$0.12	10	\$1.20
9	1" Spacers	McMaster	94639A506	100-pack	\$18.49	1	\$18.49
10	underlayment	Home Depot	99167223001	2 ft x 4 ft	\$7.69	1	\$7.69
11	plywood	Home Depot	99167044095	1/2in x 2ft x 4ft	\$12.07	1	\$12.07
12	bearings	McMaster	6338K561	flanged sleeve bearing	\$0.66	5	\$3.30
13	1/4" 20 Screw	Home Depot	887480145014	1-1/4" round head	\$1.18	4	\$4.72
14	Basswood strip	Joann Fabrics	91157040261	1/16 x 1/4 x 24	\$0.96	9	\$8.64
15	Basswood strip	Joann Fabrics	91157040667	1/4 x 1/4 x 24	\$2.79	3	\$8.37
16	Foam Brush	Joann Fabrics	90672006141	2" brush	\$0.99	2	\$1.98
17	WEN Rotary Cutting Tool	Amazon	23114	1.4-amp orange	\$32.74	1	\$32.74
18	Plasti-Dip	Home Depot	075815116031	Black 14.5oz can	\$7.68	1	\$7.68
19	Plywood	Home Depot	099167211923	1/4-2'x4'	\$10.58	1	\$10.58
20	Paint Brush	Target	81224625	1 pack	\$2.19	1	\$2.19
21	ENDUST	Target	56000091	1 pack compressed air	\$5.50	1	\$5.50
22	Paint	Target	81224628	Blue, Pink, White	\$1.09	3	\$3.27
Total:							\$191.35

APPENDIX B – FINAL DESIGN DOCUMENTATION

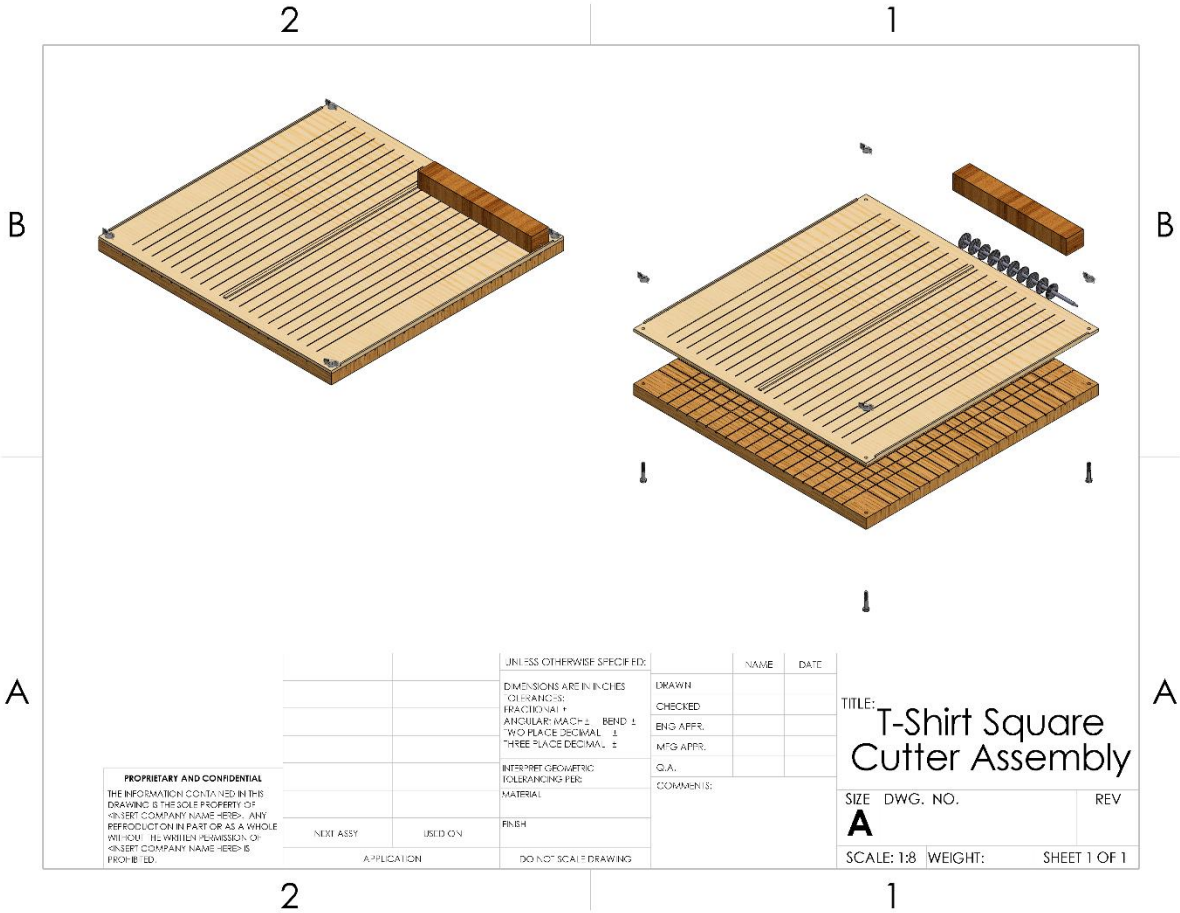

Figure B-1 Final prototype assembly in SolidWorks

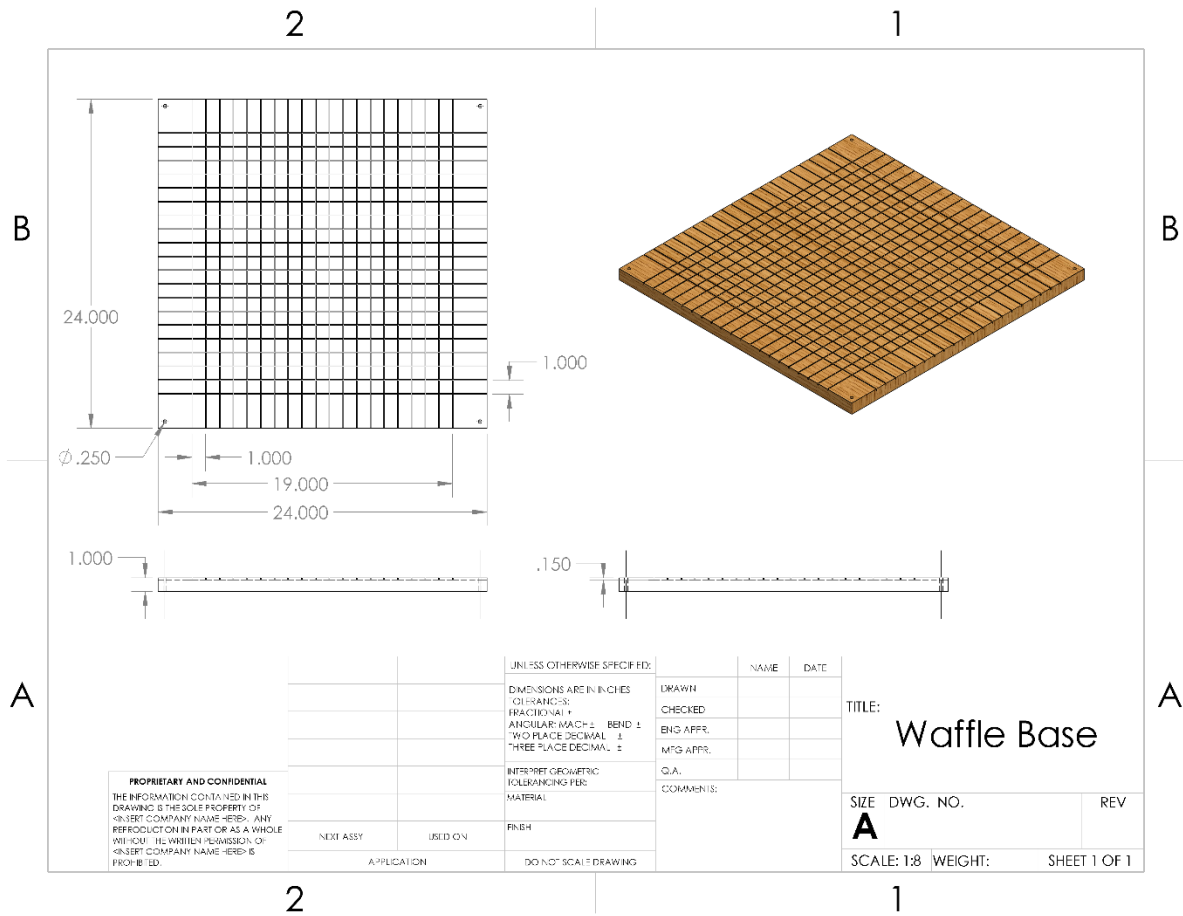

Figure B-1 Waffle base drawing with dimensions

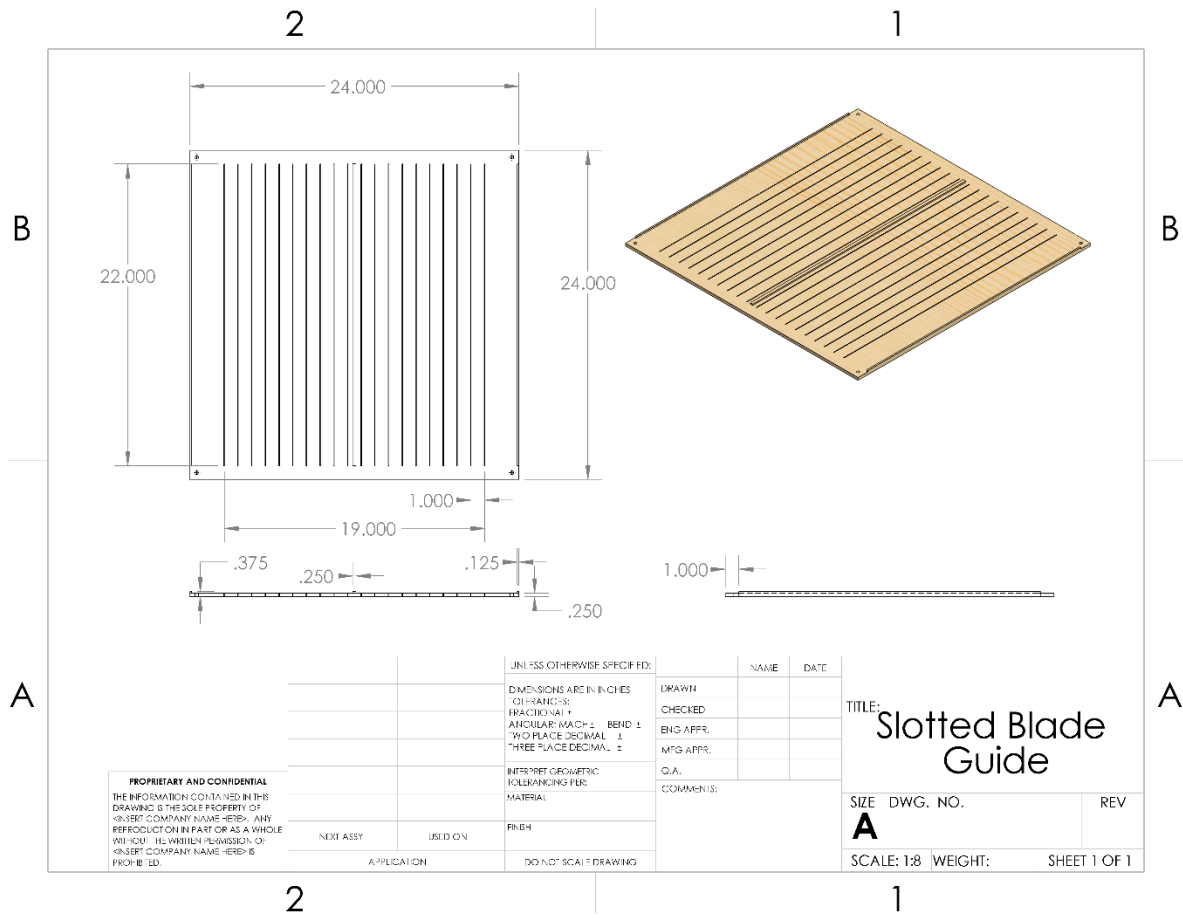

Figure B-2 Slotted base guide drawing with dimensions

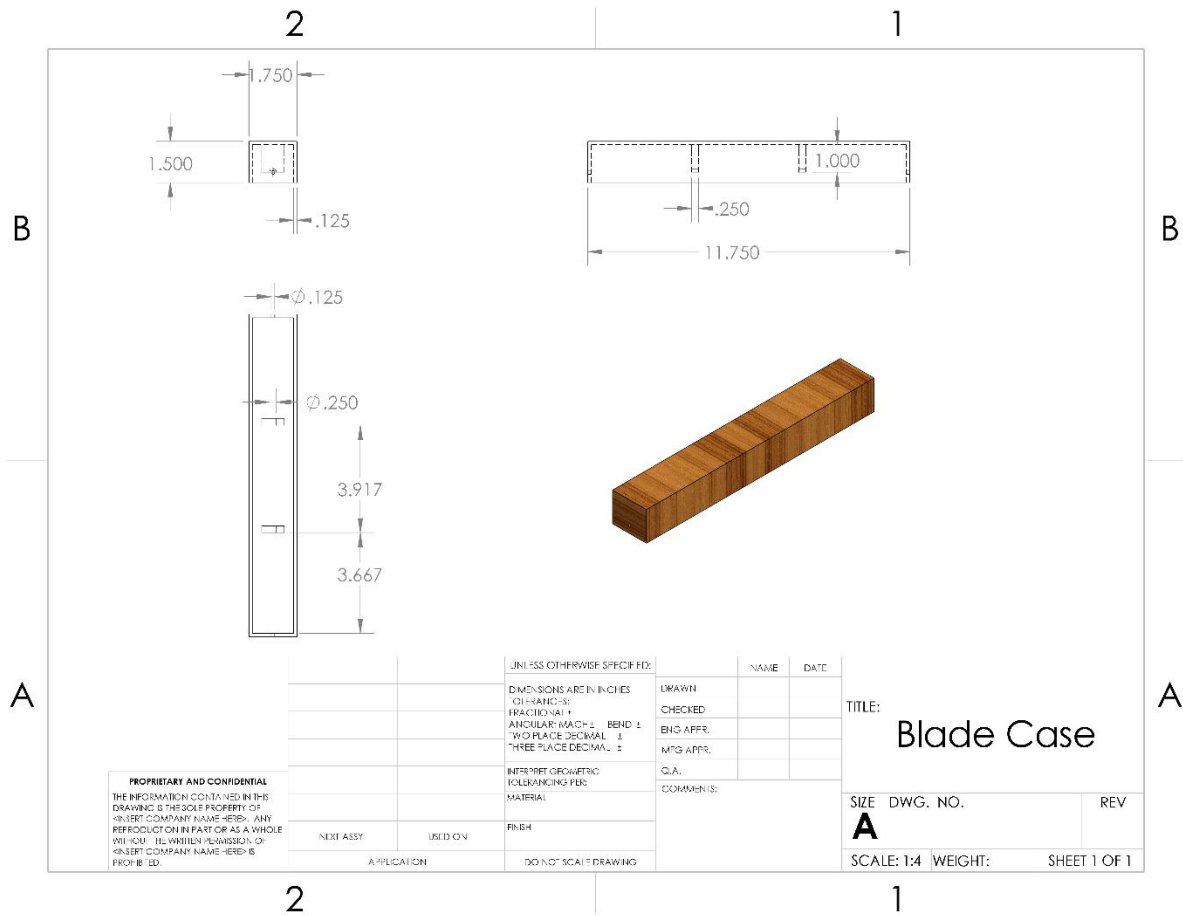

Figure B-3 Blade case drawing

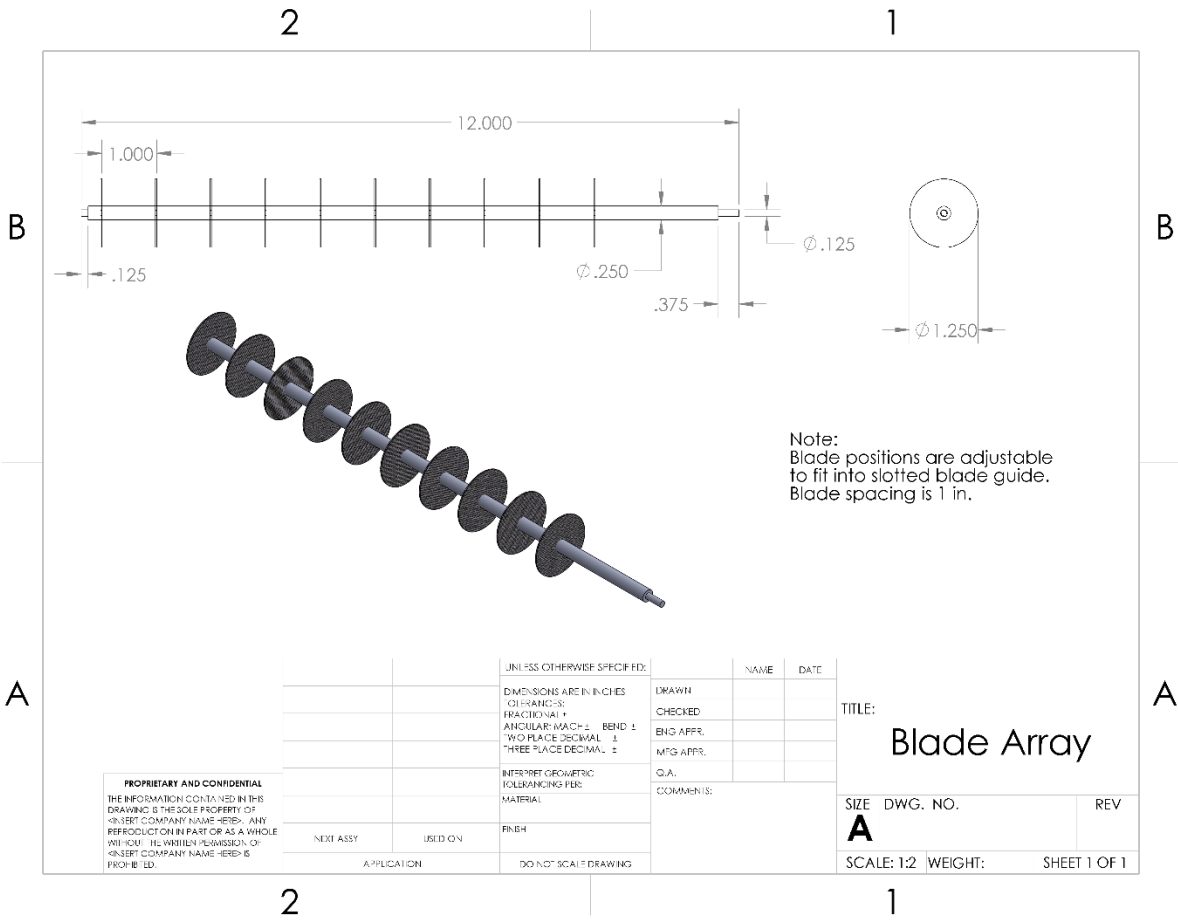

Figure B-4 Blade array drawing

Bibliography

[1] Kipp, Dale O.. (2004; 2010). *MatWeb Plastic Material Data Sheets (MDS)*. MatWeb, LLC.. Retrieved from <https://app.knovel.com/hotlink/toc/id:kpPMDS0001/matweb-plastic-material/matweb-plastic-material>

[2] Potter, J. (2018). Shafts & Flywheels [Powerpoint slides]. Retrieved from blackboard.com.