

Washington University in St. Louis

Washington University Open Scholarship

Mechanical Engineering Design Project Class

Mechanical Engineering & Materials Science

Fall 12-10-2017

3d Printed Prosthetic Hand

Mark Sullivan

Washington University in St. Louis

Bryan Oh

Washington University in St. Louis

Ian Taylor

Washington University in St. Louis

Follow this and additional works at: <https://openscholarship.wustl.edu/mems411>



Part of the [Mechanical Engineering Commons](#)

Recommended Citation

Sullivan, Mark; Oh, Bryan; and Taylor, Ian, "3d Printed Prosthetic Hand" (2017). *Mechanical Engineering Design Project Class*. 65.

<https://openscholarship.wustl.edu/mems411/65>

This Final Report is brought to you for free and open access by the Mechanical Engineering & Materials Science at Washington University Open Scholarship. It has been accepted for inclusion in Mechanical Engineering Design Project Class by an authorized administrator of Washington University Open Scholarship. For more information, please contact digital@wumail.wustl.edu.



Washington University in St. Louis

SCHOOL OF ENGINEERING & APPLIED SCIENCE

Executive Summary

3d printed prosthetic hands are a common medical device for pediatric patients with a partial hand congenital defect or amputation. These devices are appealing because 3d printing allows for cheap, fast, and accessible manufacture, and because the CAD-modeled designs are easily scalable for growing kids and can be readily customized patient-to-patient for aesthetics or functionality. We identified two key areas where current devices are lacking: grip switching and grip locking. Prosthetists agree that both the three-finger chuck and fist grip are functionally crucial, but no current non-electrical prosthetic devices allow for both. Furthermore, holding a heavy object for a prolonged duration with current devices requires the patient to continue strenuous wrist pronation. Through rigorous research, concept generation, engineering analysis, and prototype fabrication, we have remixed an open-source design to allow for toggling between fist and three-finger-chuck grips, as well as for a continuous grip lock without wrist pronation. Our prototype utilizes a novel tension pin slider mechanism and magnetic locking switch mechanism to accomplish these functions, and has performed exceptionally in performance testing. Moving forward, we hope that with the help of the robust open-source 3d printed prosthetics community, these designs can continue to be developed, and our work can positively impact the lives of pediatric partial hand patients.

MEMS 411: Senior Design Project

Group D

3D Printed Prosthetic Hand

Bryan Oh

Mark Sullivan

Ian Taylor

TABLE OF CONTENTS

List of Figures	5
List of Tables	6
1 Introduction and Background Information	7
1.1 Initial Project Description	7
1.2 Existing Products	7
1.3 Relevant Patents	14
1.4 Codes & Standards	20
1.5 Project Scope	20
1.6 Project Planning	20
1.7 Realistic Constraints	21
1.7.1 Functional	21
1.7.2 Safety	21
1.7.3 Quality	21
1.7.4 Manufacturing	21
1.7.5 Timing	21
1.7.6 Economic	21
1.7.7 Ergonomic	21
1.7.8 Ecological	21
1.7.9 Aesthetic	22
1.7.10 Life Cycle	22
1.7.11 Legal	22
1.8 Revised Project Description	22
2 Customer Needs & Product Specifications	23
2.1 Customer Interviews	23
2.2 Interpreted Customer Needs	25
2.3 Target Specifications	26
3 Concept Generation	27

3.1	Functional Decomposition	27
3.2	Morphological Chart	27
3.3	Concept #1 – “Dial-Up / Slider”	32
3.4	Concept #2 – “Gearhead”	33
3.5	Concept #3 – “Robohand”	34
3.6	Concept #4 – “Magnahand”	35
3.7	Concept #5 – “Mega Man Hand”	36
3.8	Concept #6 – “Dog Cone Hand”	37
4	Concept Selection	38
4.1	Concept Scoring Matrix	38
4.2	Explanation of Winning Concept Scores	39
4.3	Explanation of Second-Place Concept Scores	39
4.4	Explanation of Third-Place Concept Scores	39
4.5	Summary of Evaluation Results	40
5	Embodiment & Fabrication plan	41
5.1	Isometric Drawing with Bill of Materials	41
5.2	Exploded View	42
5.3	Additional Views	43
6	Engineering Analysis	46
6.1	Engineering Analysis Results	46
6.1.1	Motivation	46
6.1.2	Summary Statement of the Analysis	46
6.1.3	Methodology	47
6.1.4	Results	48
6.1.5	Significance	49
6.2	Product Risk Assessment	50
6.2.1	Risk Identification	50
6.2.2	Risk Heat Map	53
6.2.3	Risk Prioritization	53
7	Design Documentation	54
7.1	Performance Goals	54

7.2	Working Prototype Demonstration	54
7.2.1	Performance Evaluation	54
7.2.2	Working Prototype – Video Link	54
7.2.3	Working Prototype – Additional Photos	55
8	Discussion	56
8.1	Design for Manufacturing – Part Redesign for Injection Molding	56
8.1.1	Draft Analysis Results	56
8.1.2	Explanation of Design Changes	56
8.2	Design for Usability – Effect of Impairments on Usability	56
8.2.1	Vision	56
8.2.2	Hearing	57
8.2.3	Physical	57
8.2.4	Language	57
8.3	Overall Experience	58
8.3.1	Does your final project result align with the initial project description?	58
8.3.2	Was the project more or less difficult than you had expected?	58
8.3.3	In what ways do you wish your final prototype would have performed better?	58
8.3.4	Was your group missing any critical information when you evaluated concepts?	58
8.3.5	Were there additional engineering analyses that could have helped guide your design?	58
8.3.6	How did you identify your most relevant codes and standards and how they influence revision of the design?	58
8.3.7	What ethical considerations (from the Engineering Ethics and Design for Environment seminar) are relevant to your device? How could these considerations be addressed?	59
8.3.8	On which part(s) of the design process should your group have spent more time? Which parts required less time?	59
8.3.9	Was there a task on your Gantt chart that was much harder than expected? Were there any that were much easier?	59
8.3.10	Was there a component of your prototype that was significantly easier or harder to make/assemble than you expected?	59
8.3.11	If your budget were increased to 10x its original amount, would your approach have changed? If so, in what specific ways?	59
8.3.12	If you were able to take the course again with the same project and group, what would you have done differently the second time around?	60

8.3.13	Were your team member's skills complementary?	60
8.3.14	Was any needed skill missing from the group?	60
8.3.15	Has the project enhanced your design skills?	60
8.3.16	Would you now feel more comfortable accepting a design project assignment at a job?	60
8.3.17	Are there projects you would attempt now that you would not have attempted before?	60
Appendix A - Parts List		61
Appendix B - CAD Models		62
Annotated Bibliography		68

LIST OF FIGURES

- Fig. 1: K1 prosthetic hand by E-Nable.
- Fig. 2: Raptor Reloaded prosthetic hand by E-Nable.
- Fig. 3: CAD model of RIT arm by E-Nable.
- Fig. 4: Whipple tree adaptive grip mechanism utilized in the RIT arm.
- Fig. 5: Flexy hand by E-Nable.
- Fig. 6: Rotating cam gesture box.
- Fig. 7: Phoenix hand by E-Nable.
- Fig. 8: Brunel hand by Open Bionics.
- Fig. 9: Cyborg beast hand by E-Nable
- Fig. 10: HACKberry hand.
- Fig. 11: Additive manufacturing process for custom medical device.
- Fig 12: A rotary-hand prosthesis.
- Fig. 13: Patented conformal prosthetic hand in the closed position.
- Fig. 14: Patented conformal prosthetic hand in the open position.
- Fig. 15: A total hand prosthesis design.
- Fig. 16: Wrist device for use with a prosthetic limb.
- Fig. 17: A partial hand prosthesis.
- Fig. 18: The motorized control of a partial hand prosthesis.
- Fig. 19: Gantt chart.
- Fig. 20: Functional decomposition diagram for prosthetic hand.
- Fig. 21: Dial-up / slider design alternative.
- Fig. 22: Gearhead design alternative.
- Fig. 23: Robohand design alternative.
- Fig. 24 Magna hand design alternative architecture and joint mechanism.
- Fig. 25: Mega man hand design alternative.
- Fig. 26: Dog cone hand design alternative.
- Fig. 27: Isometric drawing with bill of materials.
- Fig. 28: Exploded view.
- Fig. 29: Locking Mechanism Sub-Assembly CAD Model.
- Fig. 30: Tension pin assembly view.
- Fig. 31: Slider mechanism assembly view.
- Fig. 32: Solidworks SimulationXpress analysis of tension pin.
- Fig. 33: A spring dynamometer was used to test the tension force.
- Fig. 34: Solidworks SimulationXpress analysis of tension pin.
- Fig. 35: Solidworks SimulationXpress analysis of tension pin.
- Fig. 36: Risk assessment heat map.
- Fig. 37: A top view of working prototype.
- Fig. 38: A bottom view of the working prototype.
- Fig. 39: Pre/post modification images and legend.
- Fig. 40: Locking mechanism housing CAD model.
- Fig. 41: Locking mechanism slider CAD model.
- Fig. 42: Locking mechanism neodymium bar magnet CAD model.

Fig. 43: Tension pin CAD model.

Fig. 44: Tension pin guides CAD model.

Fig. 45: Slider guide CAD model.

Fig. 46: Slider CAD model.

List of Tables

Table 1: Customer interview statements.

Table 2: Customer needs.

Table 3: Target specifications.

Table 4: Morphological chart.

Table 5: Analytical hierarchy process matrix.

Table 6: Weighted scoring matrix.

Table 7: Cost accounting table.

1 INTRODUCTION AND BACKGROUND INFORMATION

1.1 INITIAL PROJECT DESCRIPTION

3D printed prosthetic hands are a common medical device for pediatric partial hand patients due to their manufacturability and cost-effectiveness. Current designs employ a single fist grip, but prosthetists agree that the most useful grip is the three-finger chuck. Our idea is to use existing open-source prosthetic designs and remix them to allow for a user-friendly toggling mechanism between the fist and three-finger chuck grip.

1.2 EXISTING PRODUCTS

Existing design 1: K1 by E-Nable

<http://enablingthefuture.org/k-1-hand/>

This is the most commonly used 3D printed hand currently. It uses a string tensioning mechanism to allow for grip actuation upon activation, and elastics to spring the fingers back during relaxation. This design has a decent level of realism.



Fig. 1: K1 prosthetic hand by E-Nable.

Existing design 2: Raptor Reloaded by E-Nable

<http://enablingthefuture.org/upper-limb-prosthetics/raptor-reloaded/>

This design is similar to the K1, but uses a more concave finger and palm for holding objects. This design also uses tensioning pegs, for coarse and fine adjustment of the string tensions. This design has moderate realism.

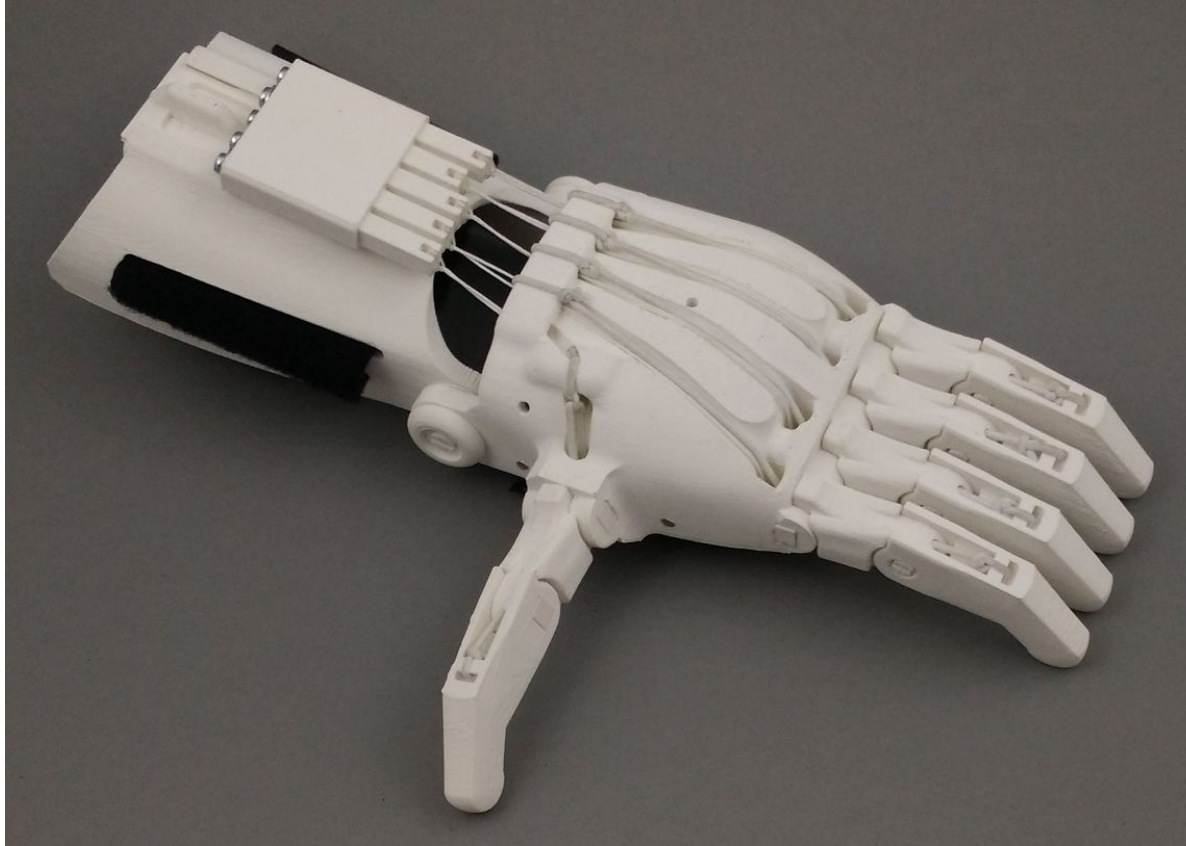

Fig. 2: Raptor Reloaded prosthetic hand by E-Nable.

Existing design 3: RIT arm by E-Nable

<http://enablingthefuture.org/upper-limb-prosthetics/rit-arm/>

This design is for transradial patients (not partial hand), however the hand design is still appealing. The fingers are attached with a whipple tree adapter allowing for an adaptive grip (i.e. curling fingers around a non-uniform object).

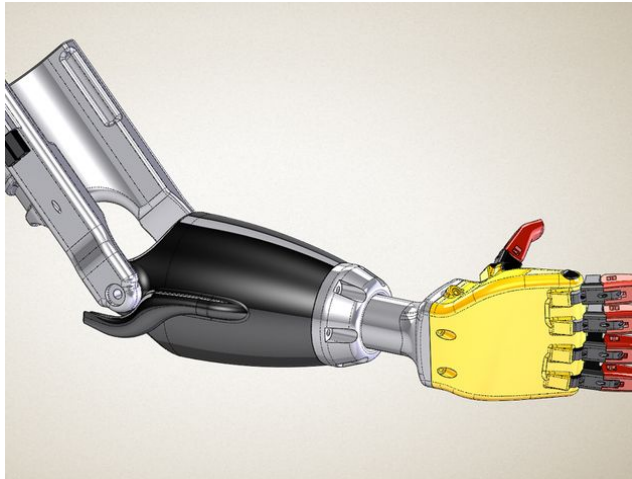

Fig. 3: CAD model of RIT arm by E-Nable.

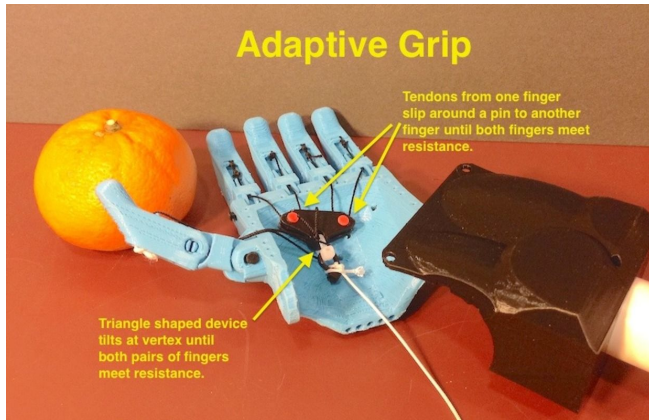

Fig. 4: Whipple tree adaptive grip mechanism utilized in the RIT arm.

Existing design 4: Flexy Hand by E-Nable

<http://enablingthefuture.org/upper-limb-prosthetics/the-flexy-hand/>

This design uses the same tensioning pin mechanism for hand closing, but uses flexible joints to return the hand to its resting state. These joints allow for more natural-looking fingers.



Fig. 5: Flexy hand by E-Nable.

Existing design 5: Remixed raptor reloaded with cam gesture box

<https://www.thingiverse.com/thing:890953>

This is a proof-of-concept design found on Thingiverse, which employs a rotating cam to yield a variety of grips. Each grip corresponds to a set of cams of specific radii, placing the appropriate tensions on each finger line to give the desired grip. This is one approach to toggling grips on a mechanical prosthetic hand, though it is bulky.



Fig. 6: Rotating cam gesture box.

Existing design 6: Phoenix Hand v2 by E-Nable

<https://www.thingiverse.com/thing:1453190>

This design is similar to the Raptor Reloaded, and is moderately realistic. However there are a few key differences: the fingers strings are not exposed, and this angle of the thumb allows for a pinch grip.



Fig. 7: Phoenix hand by E-Nable.

Existing design 7: Brunel hand by Open Bionics

<https://www.openbionics.com/shop/brunel-hand>

The Brunel hand is a 3d printed design that is purchasable. It is very realistic, and also servo motor-controlled using surface electromyography. This design is cutting-edge, and quite expensive.



Fig. 8: Brunel hand by Open Bionics.

Existing design 8: Cyborg beast hand by E-Nable

<http://enablingthefuture.org/current-design-files/cyborg-beast-hand/>

The Cyborg beast is an exceptionally popular design historically, though advancements have been made since its release. It is easy to assemble, and includes a simple string/elastic actuation method. It also employs a tension pin system. However, it is not aesthetically pleasing and is somewhat unwieldy.



Fig. 9: Cyborg beast hand by E-Nable

Existing design 9: HACKberry hand

<http://exiii-hackberry.com/>

The HACKberry is a 3D printed bionic hand with electrical controls and motorized actuation. The hand is open-source, and employs the appealing integration of motors into the palm: it avoids strings, and drives actuation directly with gears and linkages.



Fig. 10: HACKberry hand.

1.3 RELEVANT PATENTS

Patent 1: Use of additive manufacturing processes in the manufacture of custom wearable and/or implantable medical devices

US20170036402A1

This patent describes the use of a physical or digital model of a patient's healthy limb in the design of the prosthetic for the residual limb. This is a very appealing idea to use for prosthetic hands, as it would add to the customizability and realism of the device.

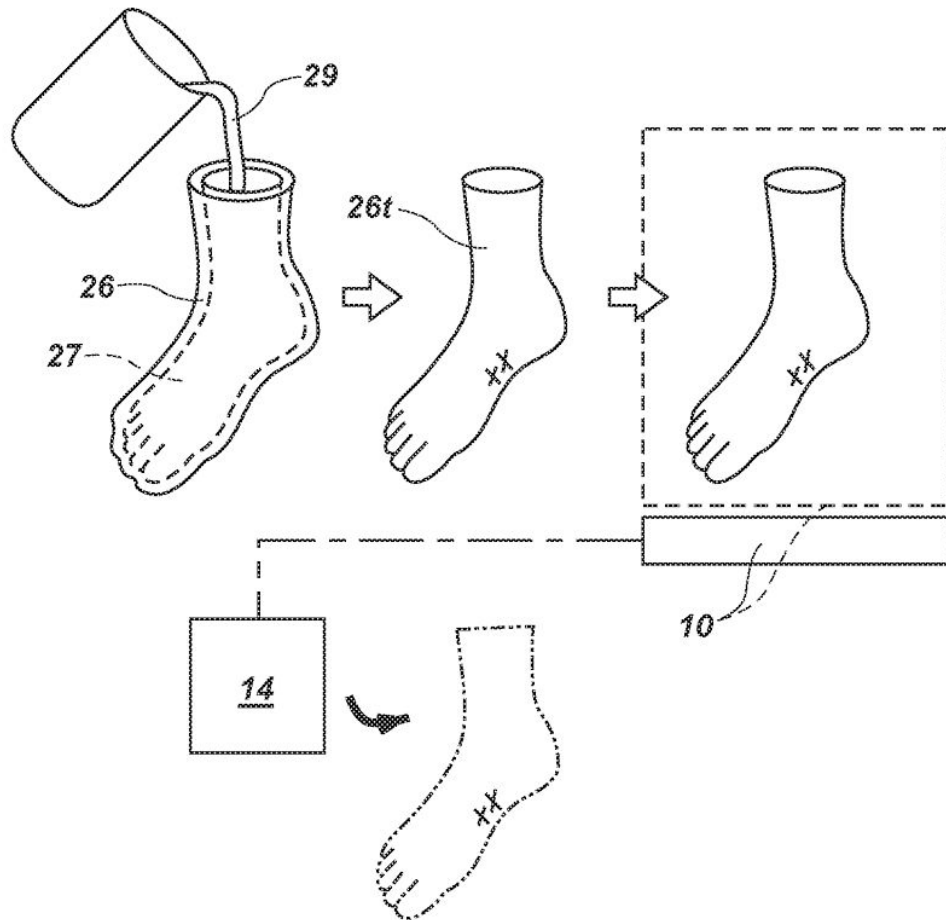

Fig. 11: Additive manufacturing process for custom medical device.

**Patent 2: Rotary hand prosthesis
US4990162A**

This patent describes a rotary-based prosthetic hand device. The design is more functional than aesthetic, and includes two gripping members. An appealing component of this design is that it allows for two different grip patterns.

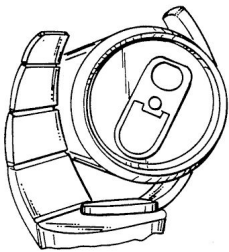
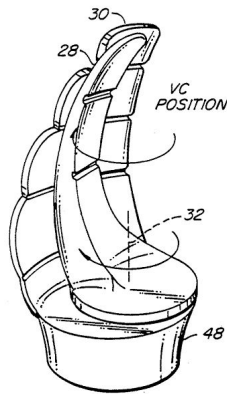

FIG. 6.

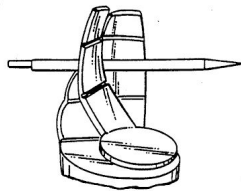

FIG. 7.

Fig 12: A rotary-hand prosthesis.

Patent 3: Prosthetic hand having a conformal, compliant grip and opposable, functional thumb
US 2006/0224249 A1

This patent describes a prosthetic hand design with a number of interesting features. The hand includes a compliant grip, allowing for the adaptive gripping of nonuniform objects. It also has a jointed opposable thumb design. This simple device design is adaptable to body-powered and electric-powered actuation schemes.

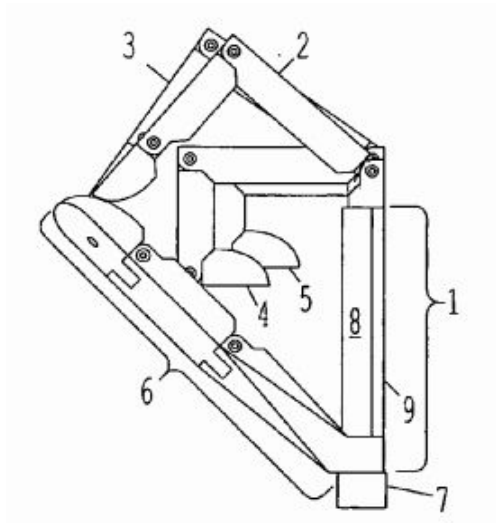

Fig. 13: Patented conformal prosthetic hand in the closed position.

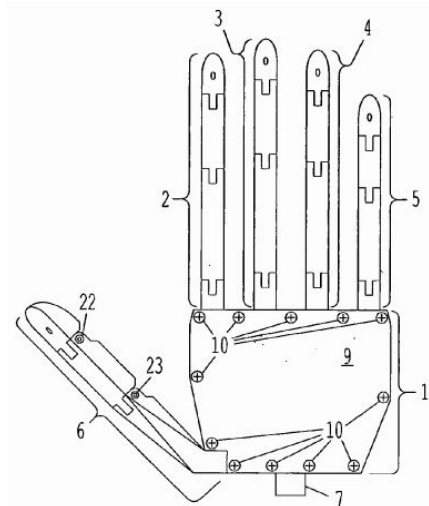

Fig. 14: Patented conformal prosthetic hand in the open position.

Patent 4: Total hand prostheses
US4685929

This patent describes a hand prosthesis with cable actuation and spring relaxation. Interesting features of this design are the ball joint elements at finger joints, as well as the soft gripping material. This hand is designed to have a realistic covering.

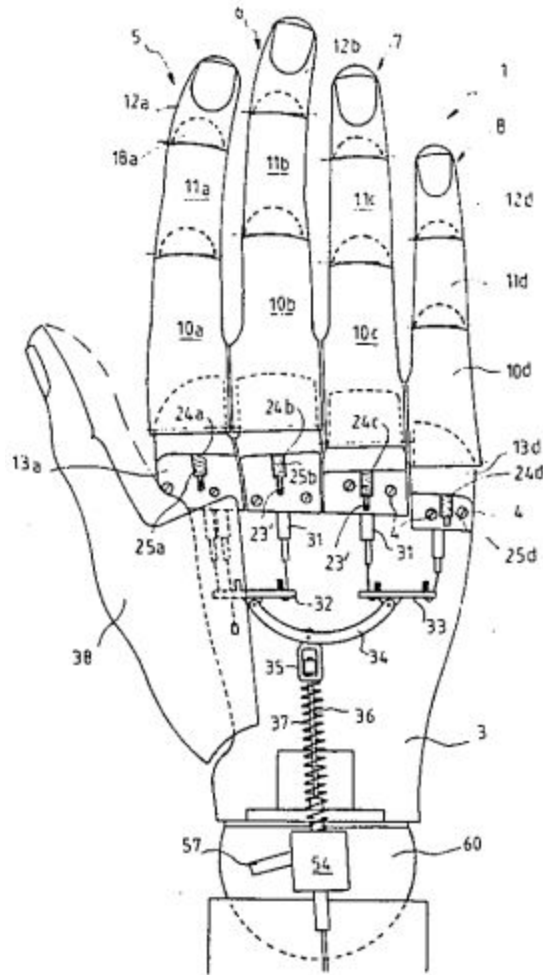

Fig. 15: A total hand prosthesis design.

**Patent 5: Wrist device for use with a prosthetic limb
US7144430B2**

This device is specifically designed to interface with prosthetic hands, and allows for wrist actuation. This device's bridging capability allows not only for wrist movement, but also for additional functionality and space beyond the wrist (towards the forearm) which could be utilized for features.

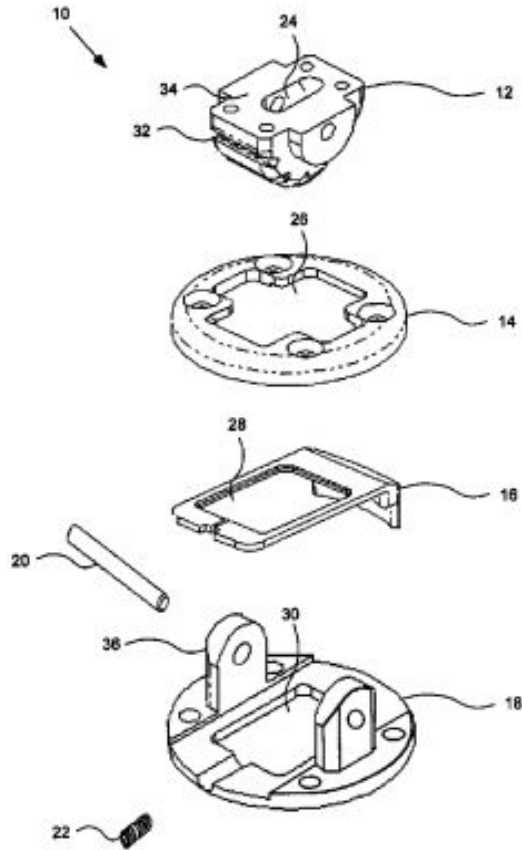

Fig. 16: Wrist device for use with a prosthetic limb.

Patent 6: Partial hand prosthesis
US2006/0212129A1

This device is unique in a number of ways. It is powered, using motors a battery, and uses a microprocessor with the signal input being from internal force sensors, activated by the partial hand. It also employs a realistic cosmetic design. Only one actuation pattern is allowed.

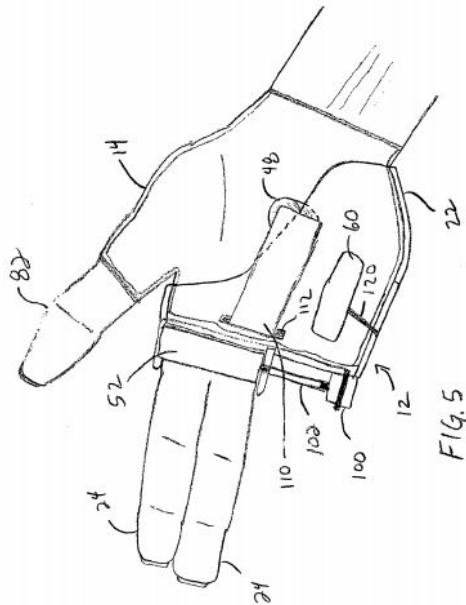

Fig. 17: A partial hand prosthesis.

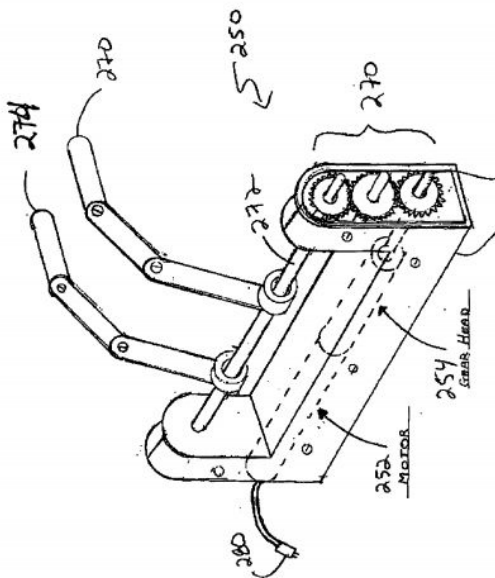

Fig. 18: The motorized control of a partial hand prosthesis.

1.4 CODES & STANDARDS

Prosthetics - Structural testing of lower limb prostheses - Requirements and test methods (ISO 10328:2016)

- 15.2: Static test procedure
- 10.6 Worst case alignment position of test samples

1.5 PROJECT SCOPE

The project should result with a prosthetic hand device which can easily switch grips between the three-finger-chuck and fist, easily lock a given grip into place, and be reasonably scalable and manufacturable.

The project will not result in a prosthetic hand device that is entirely 3d printed. The device will not have electrical components. The device will not cater to people outside of partial hand pediatric patients.

1.6 PROJECT PLANNING

Since the project concept was changed early in the semester, the Gantt chart was modified appropriately and many items had to be re-done and altered. Besides that, we successfully followed our timeline to the end of the semester.

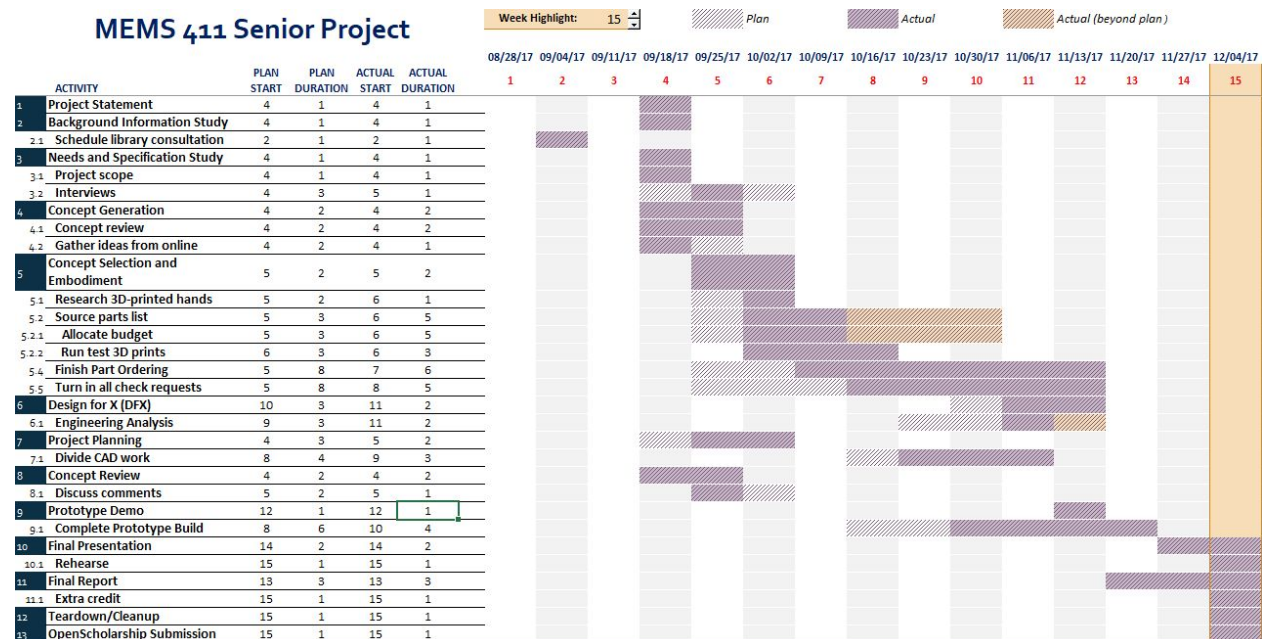

Fig. 19: Gantt chart.

1.7 REALISTIC CONSTRAINTS

Our project involves a number of real-world constraints spanning a breadth of areas.

1.7.1 Functional

The device is functionally constrained by natural pediatric hand activity. The device itself should only be capable of natural hand movements. Otherwise, the device will be unnatural and unappealing to patients.

1.7.2 Safety

Our project is a wearable device, which means that both in testing and in the field the device will directly interact with people. Failure modes of the device and prototypes should be examined as to not cause harm.

1.7.3 Quality

Our device's quality is constrained by the precision and capabilities of standard 3d printers. This may yield less-than-desirable tolerances, and so the design should account for these. The quality of our prototype is specifically constrained by campus and personal 3d printers.

1.7.4 Manufacturing

Our device is constrained in manufacture by 3d printing, as it is crucial that this device is primarily 3d printed. Non-3d-printed parts need to be avoided when necessary to keep costs low and maintain scalability.

1.7.5 Timing

The length of our project is constrained by the timeline of the senior design course: it needs to be completed by the beginning of December, 2017. The assembly of our prototypes will be constrained by part ordering times, and should be accounted for in project planning. The 3d printed parts are constrained by the print duration, but since two group members own 3d printers, and these parts will only take a few hours maximum, this should not be a significant factor.

1.7.6 Economic

The components we order are constrained by our budget of \$230.40. Since a primary motivation of this device is ease of manufacture and cost-effectiveness, ideally our budget will not be too large of a constraint unless it is decided to explore more expensive materials.

1.7.7 Ergonomic

The device must be able to comfortably fit on a pediatric partial hand patient. This constrains the the shape of the partial hand interface, as well as the weight of the completed device. The mechanisms must be easily operated by small children.

1.7.8 Ecological

Our project is ecologically constrained by the weather and climate of St. Louis in fall and winter. Some 3d printed thermoplastic parts may respond differently in different climates, but we will not be able to test for those.

1.7.9 Aesthetic

Our device is heavily constrained aesthetically- if the prosthetic does not look appealing, patients will not wear it. Aesthetics is especially important for pediatric patients, because having an appealing prosthesis can be hugely positive for their self-image, as well as personal and social development.

1.7.10 Life Cycle

Our project is constrained by the anticipated life cycle of the eventual final product. The device is for pediatric patients, who will grow and require a new prosthesis about every year or eighteen months. To account for this constraint, our device must be easily scalable using CAD software.

1.7.11 Legal

A legal constraint for our project is that without clearance by medical professionals and governing bodies, we will not be able to test our device on actual patients. We will have to test the device ourselves.

1.8 REVISED PROJECT DESCRIPTION

3D printed prosthetic hands are a common medical device for pediatric partial hand patients due to their manufacturability and cost-effectiveness. Current designs employ a single fist grip, but prosthetists agree that the most useful grip is the three-finger chuck. Our idea is to use existing open-source prosthetic designs and remix them to allow for a toggling mechanism between the fist and three-finger chuck grip, a user-friendly grip locking mechanism, and an adaptive grip mechanism. These mechanisms should be user-friendly and maintain the cost-effectiveness, simple manufacture and assembly, and scalability of current designs.

2 CUSTOMER NEEDS & PRODUCT SPECIFICATIONS

2.1 CUSTOMER INTERVIEWS

<p>Customer Data: Customer: Nick Thompson, Patients who have partial hand amputations/deformities Address: Shriners Hospital Date: 9/12/17</p>			
Question	Customer Statement	Interpreted Need	Importance
What kind of grips are useful for patients	Fist grip is good but 3-finger chuck grip is vital to a useful prosthetic	The device has both a fist and 3-finger chuck grip	5
What user-friendly toggling feature should be included	A dial or lever could be operated by the intact limb to change the kinds of grips	The mechanism to change the grip can be operated by the healthy limb	4
Is partial hand amputation one of the more common upper extremity amputee injuries?	Partial hand amputation is more prevalent than other abnormalities, and designs to cater to it can be modified to compensate for other common abnormalities (i.e. missing digits).	The device caters to partial hand amputation patients	5
What are your thoughts on how to tension the fingers	It would be ideal to use something similar to the Whipple Tree, where each finger does not have an individual tension line. This makes it easier to close the hand, provides the same articulation, and allows for an adaptive grip	The device has adjustable finger tensioning	4
What is a reasonable cost for the device	Each device should cost around 15-30\$. PLA should be used and hardware can be bought for around 15-20\$. So the total	The device costs 15\$-30\$.	5

	cost of materials to make several will end up around 50\$		
Should we use 3-D printed bolts or metal bolts	If you don't have time to go through several iterations and figure out the material properties of the print then just use metal hardware, it is easier and more reliable	The device uses metal hardware	3
What is a reasonable weight for the device	Anything under 2 lbs is reasonable.	The device weighs <2 Lbs	4
What is a reasonable size for the device	I wouldn't push the cuff of the arm past the elbow to allow for mobility. Other than that the size of the arm can be a little bit bigger than the patient's arm.	Device length is below the elbow	5
What materials should we use for the device?	Print in PLA for the hand and try out different materials for the finger grip and the elastic tensioning lines.	The device is made out of PLA	4
How should we 3D print the device	The ideal is around 35%-65% infill. Do not use below 25% infill. Use at least 4 shells	The device is printed with at least 25% infill and 4 shells	3
Are there any problems you see with current pinch grip implementations	Many times hands used will have a thumb that has a middle joint that bends to bring the thumb together with the other fingers. This does not provide a good grip, ideally the thumb would bend at the knuckle joint to provide more of a flat platform to grab things.	The device's thumb remains stiff during the 3-finger chuck grip.	4
What are some patient complaints that you've had?	That the fingers are not grippy enough and that objects will slip out of their hand.	The device firmly grips objects	5

What advice do you have for us when we design the hand	Scalability is important but it has to be within reason. Make designs that are easy to modify.	The device is scalable and easily alterable	4
--	--	---	---

Table 1: Customer interview statements.

2.2 INTERPRETED CUSTOMER NEEDS

Need Number	Need	Importance
1	The device has both a fist and 3-finger chuck grip	5
2	The mechanism to change the grip can be operated by the intact limb	4
3	The device caters to partial hand amputation patients	5
4	The device has adjustable finger tensioning	4
5	The device costs 15\$-30\$.	5
6	The device uses metal hardware	3
7	The device weighs <2 Lbs	4
8	Device length is below the elbow	5
9	The device is made out of PLA	4
10	The device is printed with at least 25% infill and 4 shells	3
11	The device's thumb remains stiff during the 3-finger chuck grip.	5
12	The device firmly grips objects	5
13	The device is scalable and easily alterable	4

Table 2: Customer needs.

2.3 TARGET SPECIFICATIONS

Metric Number	Associated Needs	Metric	Units	Acceptable	Ideal	Source
1	7	Weight	lbs	2	<2	Need
2	10	Infill	%	25	35-65	Need
3	5	Cost	\$	30	15	Need
4	10	Shells	integer	4	>=4	Need
5	9	Material	binary	-	PLA	Need
6	4	Tensioning Force	lbf	<10	2	Need
7	8	Length	ft	-	1.75-.5	Need
8	12	Sliding Friction	lbf	5	8-14	Need
9	13	Scalability	%	90-110	80-125	Need
10	13	Adaptability	binary	-	All parts are 3D Printed	Need
11	10, 12	Typical structural strength	binary	-	Device sustains typical severe loading conditions	Standard
12	10, 12	Worst-case structural strength	binary	-	Device sustains worst-case loading conditions	Standard

Table 3: Target specifications.

3 CONCEPT GENERATION

3.1 FUNCTIONAL DECOMPOSITION

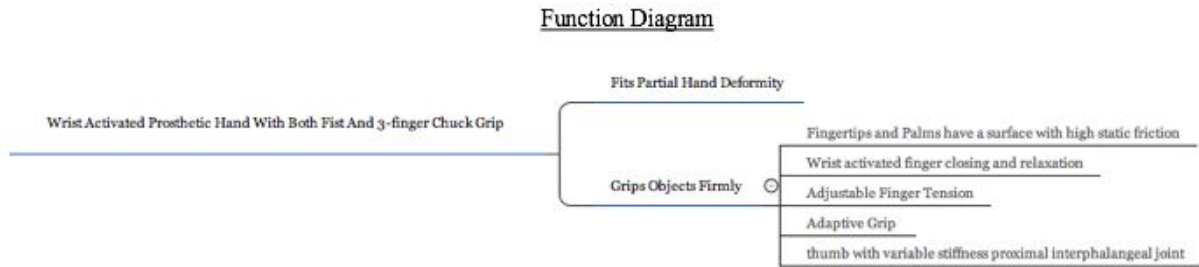
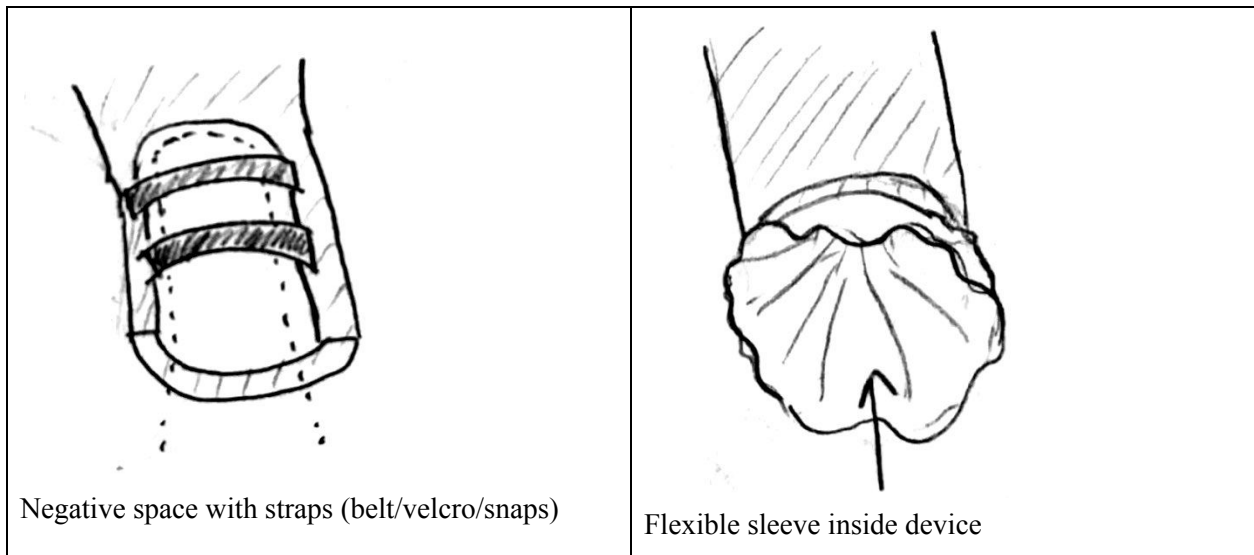

Fig. 20: Functional decomposition diagram for prosthetic hand.

3.2 MORPHOLOGICAL CHART

Fits partial hand deformity



Friction on Fingertips

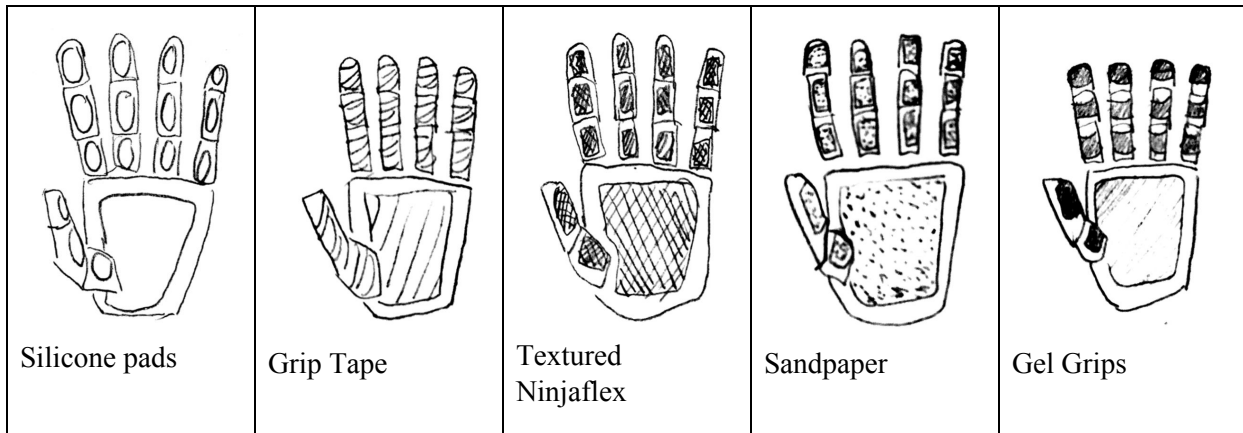

Wrist-activated hand opening and closing

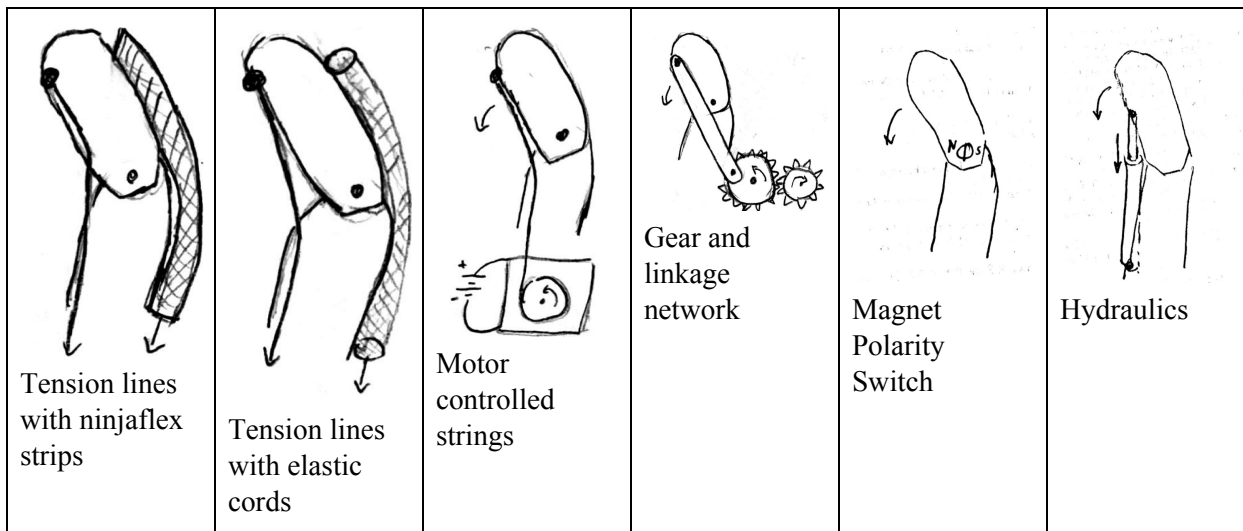

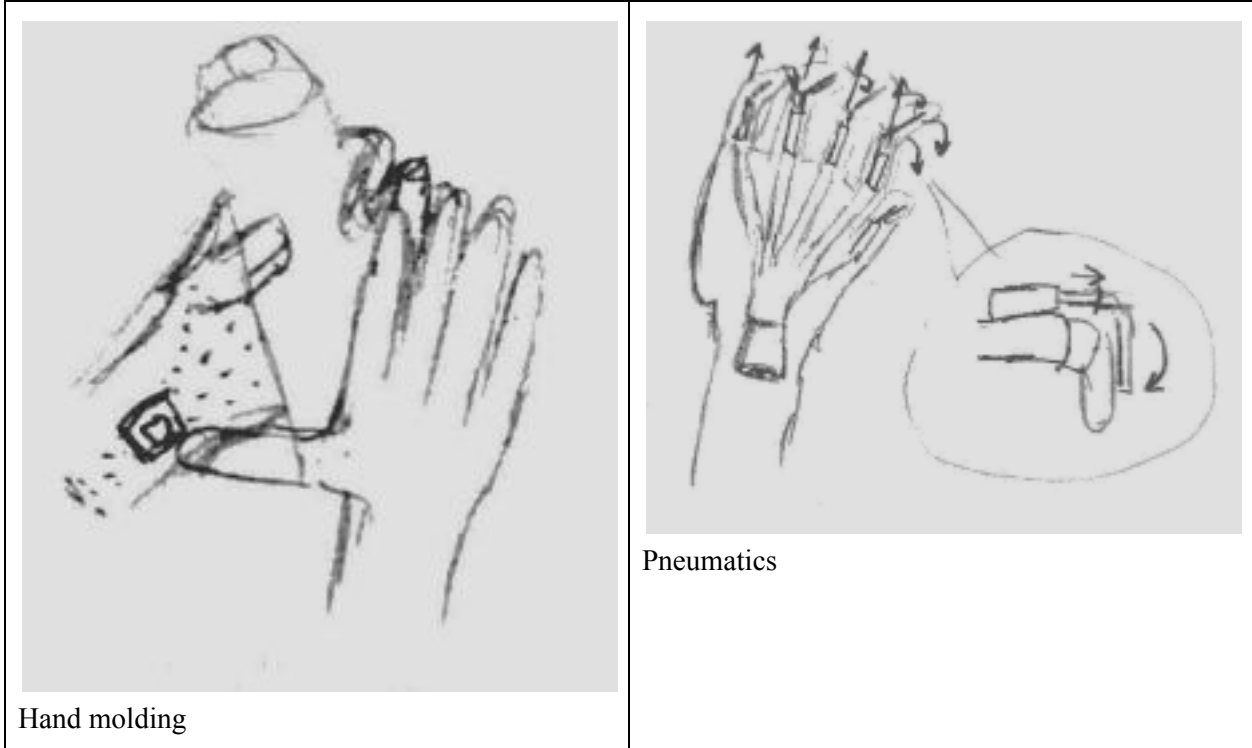

Adjustable finger actuation

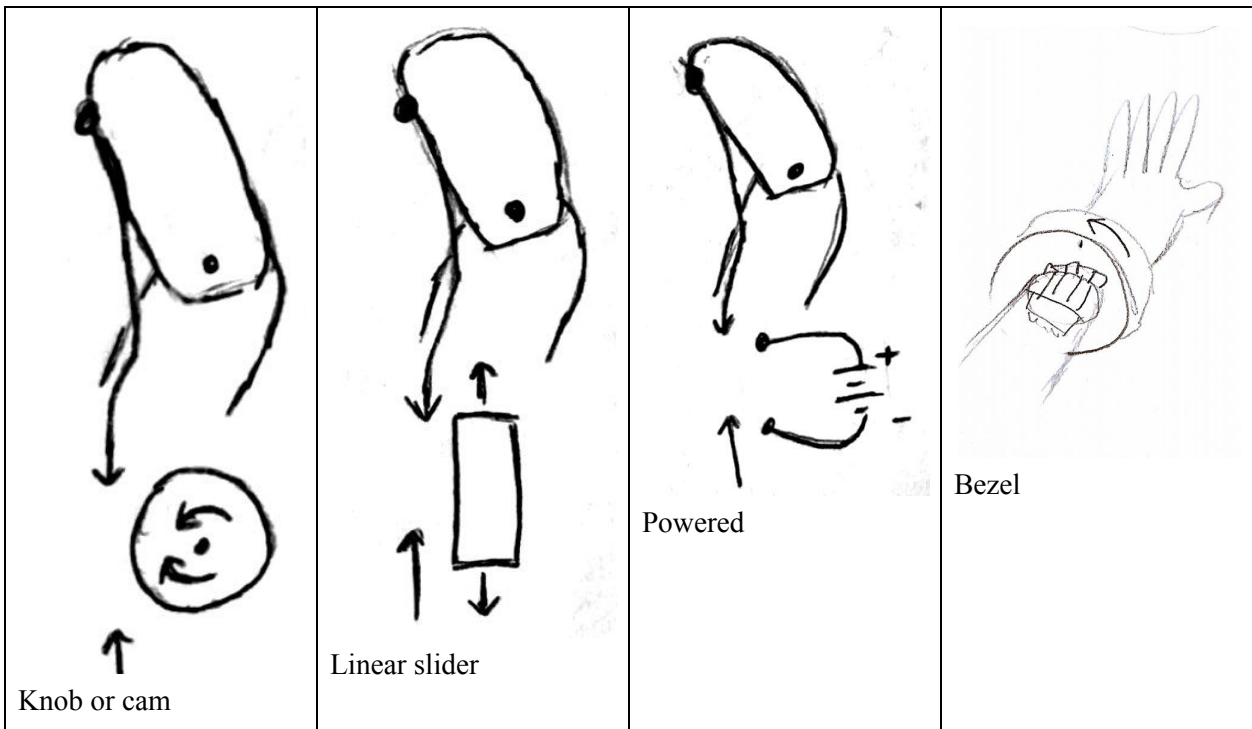

Adaptive grip

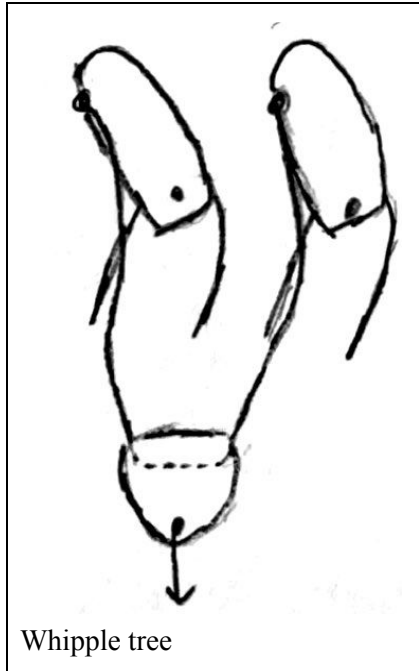

Whipple tree

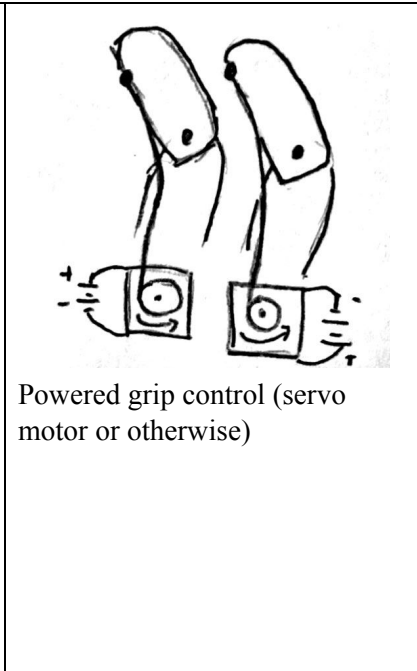

Powered grip control (servo motor or otherwise)

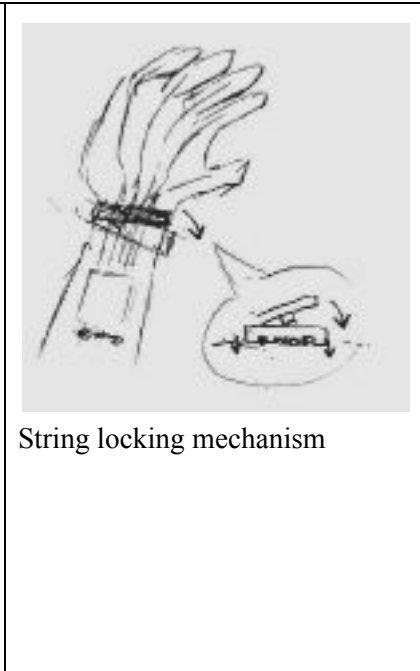

String locking mechanism

Variable finger stiffness

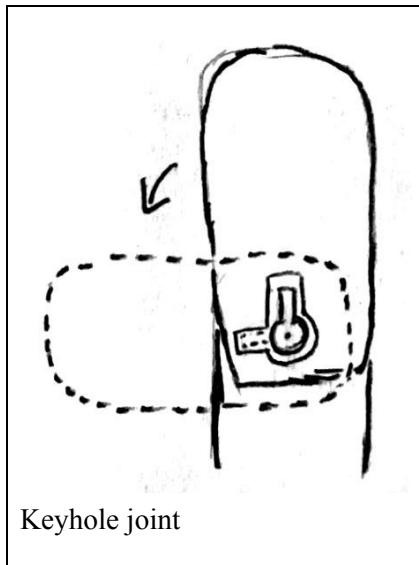

Keyhole joint

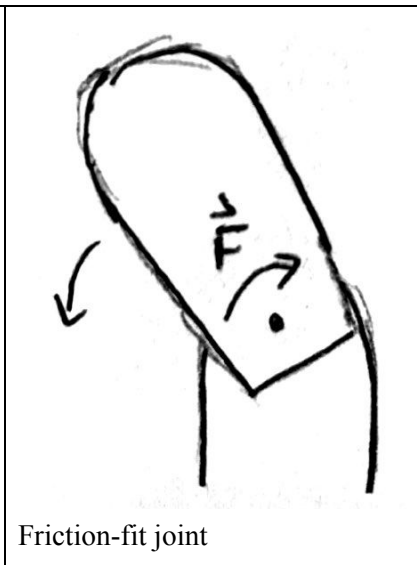

Friction-fit joint

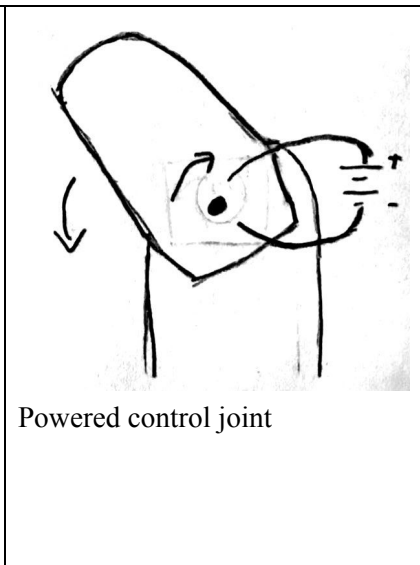

Powered control joint

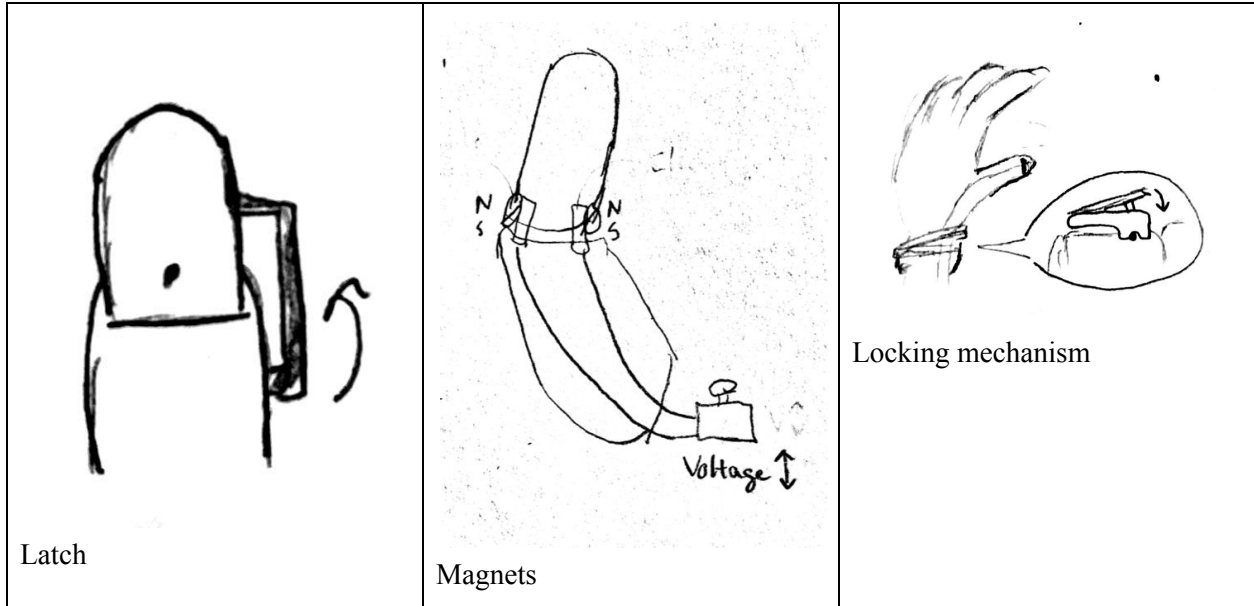

Table 4: Morphological chart.

3.3 CONCEPT #1 – “DIAL-UP / SLIDER”

Solutions:

1. Sleeve
2. Gel grips
3. Tensioned strings for closing and elastic strings for opening
4. Tensioner dial / tensioner slider
5. Whipple tree
6. Latch

When the user rotates their partial hand about their wrist, tensioned strings wound around the front of the fingers pull the fingers closed. Elastic straps along the backsides relax them back for opening. A tensioner dial or a tension pin dial modify the tension on the thumb in order to allow for both a fist grip (thumb outside the fingers) and a three finger chuck grip (thumb contacts first two fingers). A whipple tree on the four fingers allows for an adaptive grip.

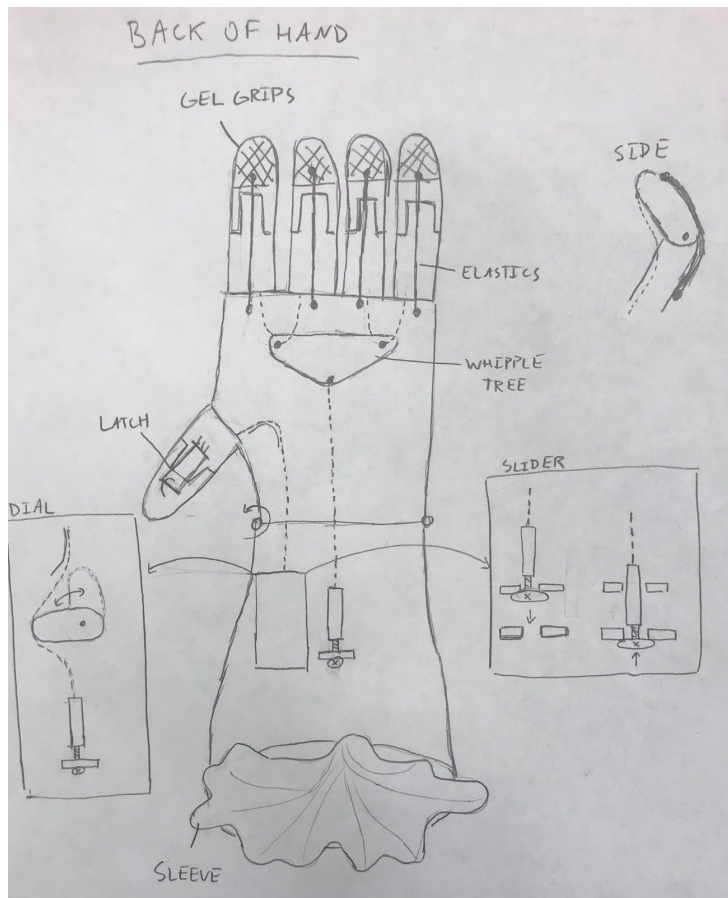

Fig. 21: Dial-up / slider design alternative.

3.4 CONCEPT #2 – “GEARHEAD”

Solutions:

1. Velcro straps
2. Textured ninjaflex
3. Gear and linkage
4. Gear slider
5. (none)
6. Keyhole

This design is purely gear and linkage driven: wrist actuation turns gears and linkages to pull the fingers and thumbs closed and then open again. There are two different linkage positions on the thumb to allow for both the fist and the three finger chuck grip. A keyhole mechanism allows for variable thumb joint stiffness.

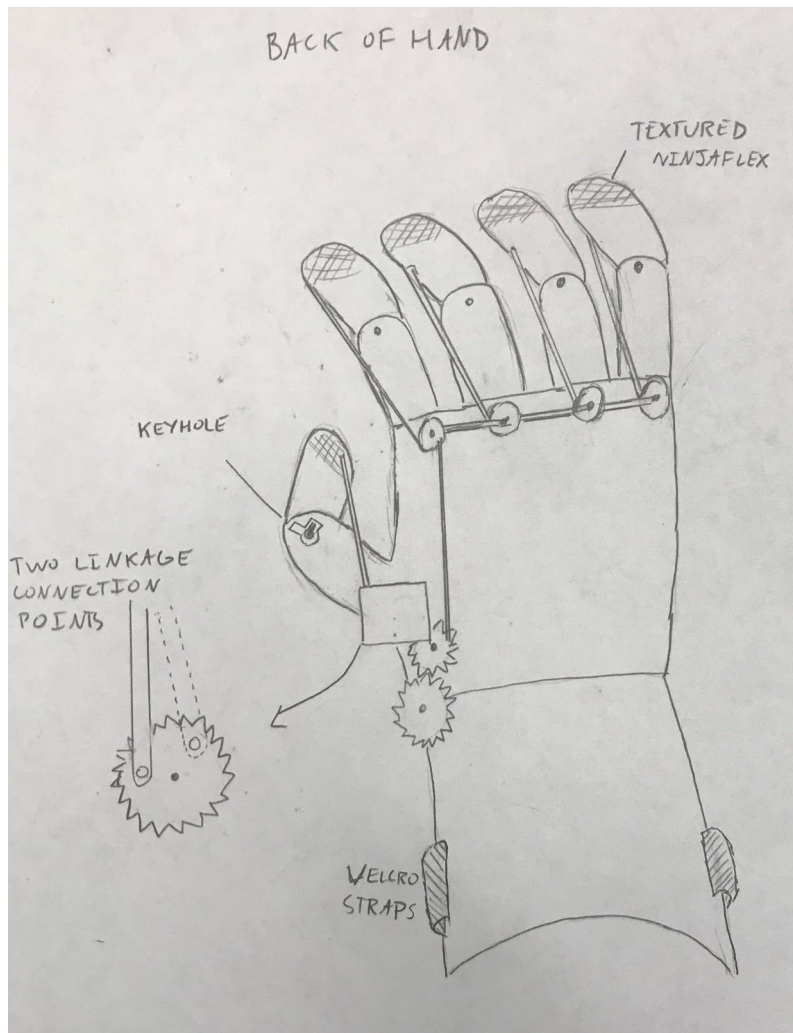

Fig. 22: Gearhead design alternative.

3.5 CONCEPT #3 – “ROBOHAND”

Solutions:

1. Metal snaps
2. Silicone pads
3. Motor and ninjaflex strips
4. Motor
5. Motor
6. Motor

This hand is entirely electrical and motor-driven. 5 servos pull strings to control each finger, and an additional servo controls the thumb joint to allow for both the fist and the three finger chuck grip. The system is controlled by a microprocessor and powered by appropriate batteries.

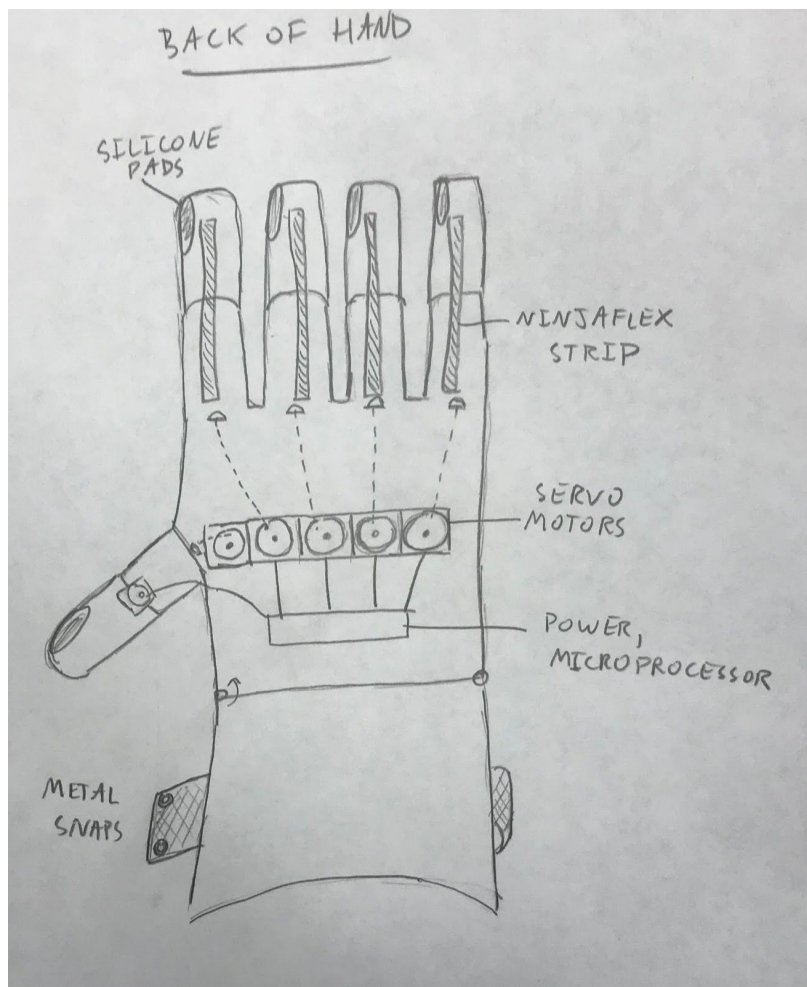

Fig. 23: Robohand design alternative.

3.6 CONCEPT #4 – “MAGNA HAND”

Solutions:

1. Sleeve
2. Texture Ninjaflex
3. Magnet Polarity Switch
4. Power Control
5. Whipple Tree
6. Magnets

This hand is driven entirely by the interaction between dipole magnets implanted next to electromagnets within the joints of the fingers. These actuate when the user moves the wrist joint to activate a switch that will turn on the electromagnets. The electromagnet strength and therefore the strength of the grip and stiffness of the thumb can be modified by changing the voltage supplied to the electromagnets using a power controller mounted on the wrist. A whipple tree is implemented on 4 of the fingers to maintain an adaptive grip.

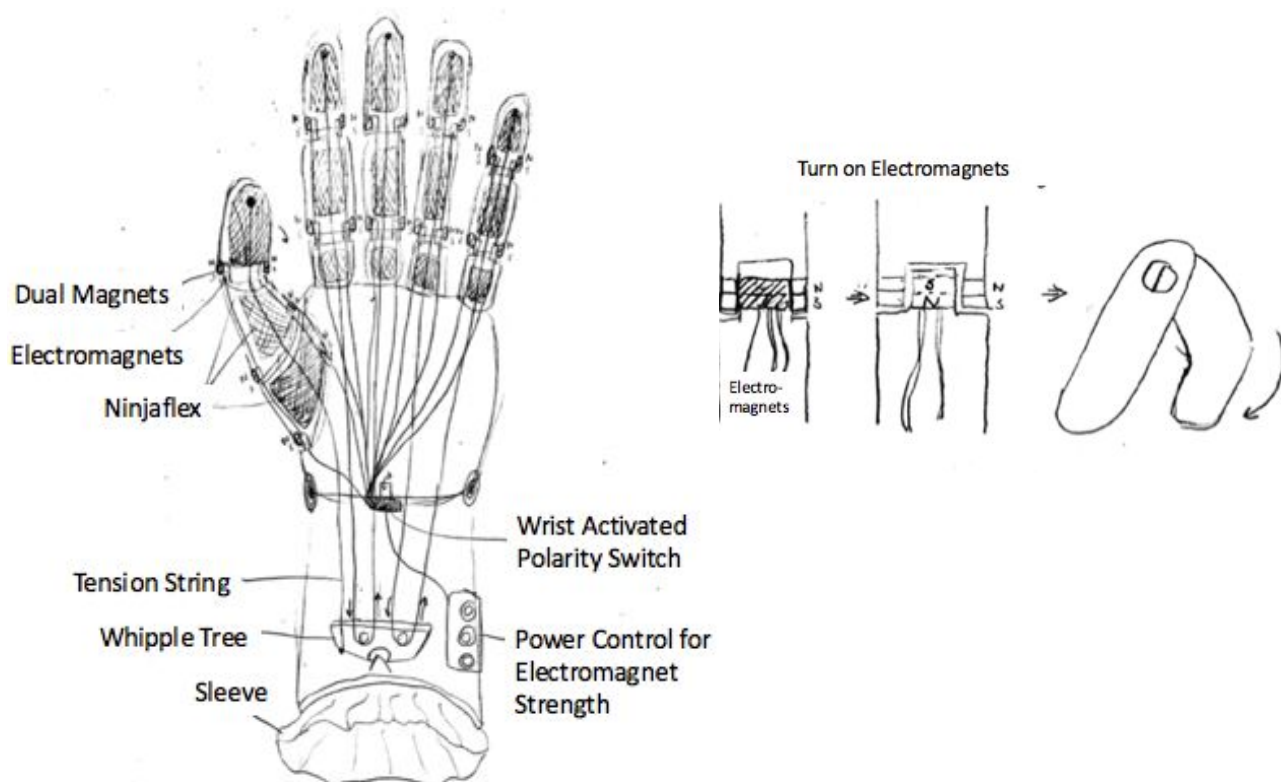

Fig. 24 Magna hand design alternative architecture and joint mechanism.

3.7 CONCEPT #5 – “MEGA MAN HAND”

Solutions:

1. Gel grips
2. Tension String
3. Bezel
4. Locking Mechanism
5. Tension Line Locking Mechanism

The Mega Man Hand’s stand-out feature is the rotating bezel that includes a tension string locking mechanism. By rotating the bezel, the user may switch between different grips since the locking mechanism will selectively control the tension of certain strings. Gel grips will be placed on the palm and fingertips to aid in grip.

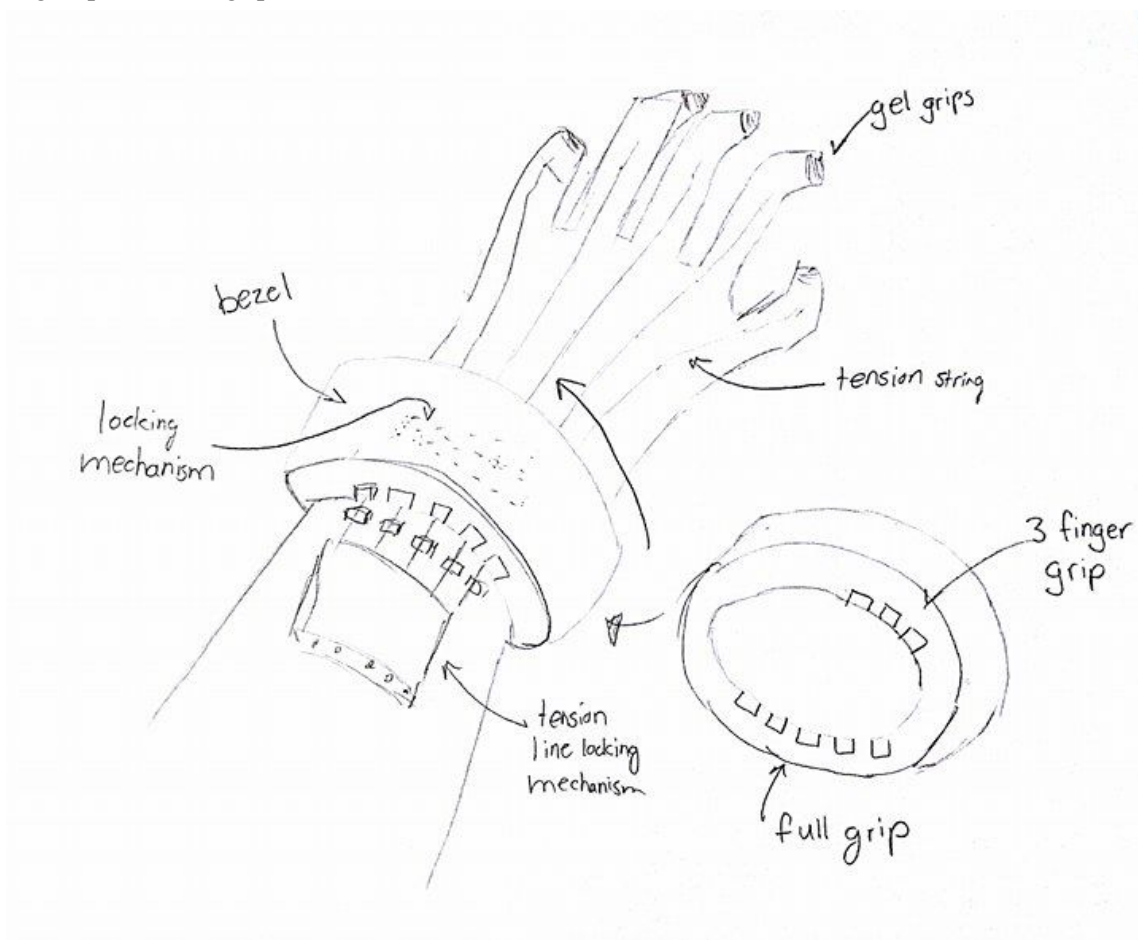

Fig. 25: Mega man hand design alternative.

3.8 CONCEPT #6 – “DOG CONE HAND”

Solutions:

1. Sandpaper
2. Tension strings
3. Whipple Tree
4. Linear Slider
5. Keyhole Joint

The Dog Cone Hand operates like a marionette in that the user may fine-tune his/her grip by rotating their wrist and selectively increase or decrease tension of the strings attached to the fingers. A main string tensioner responsible for the bulk of the tension force is also present. The keyhole joints will move fairly easily and will be cheap to produce. Linear sliders in conjunction with the tension strings will aid in the tightening motion. Sandpaper will be used for the fingertips for extra grip. The keyhole joints will move fairly easily and will be cheap to produce. Linear sliders in conjunction with the tension strings will aid in the tightening motion. Sandpaper will be used for the fingertips for extra grip.

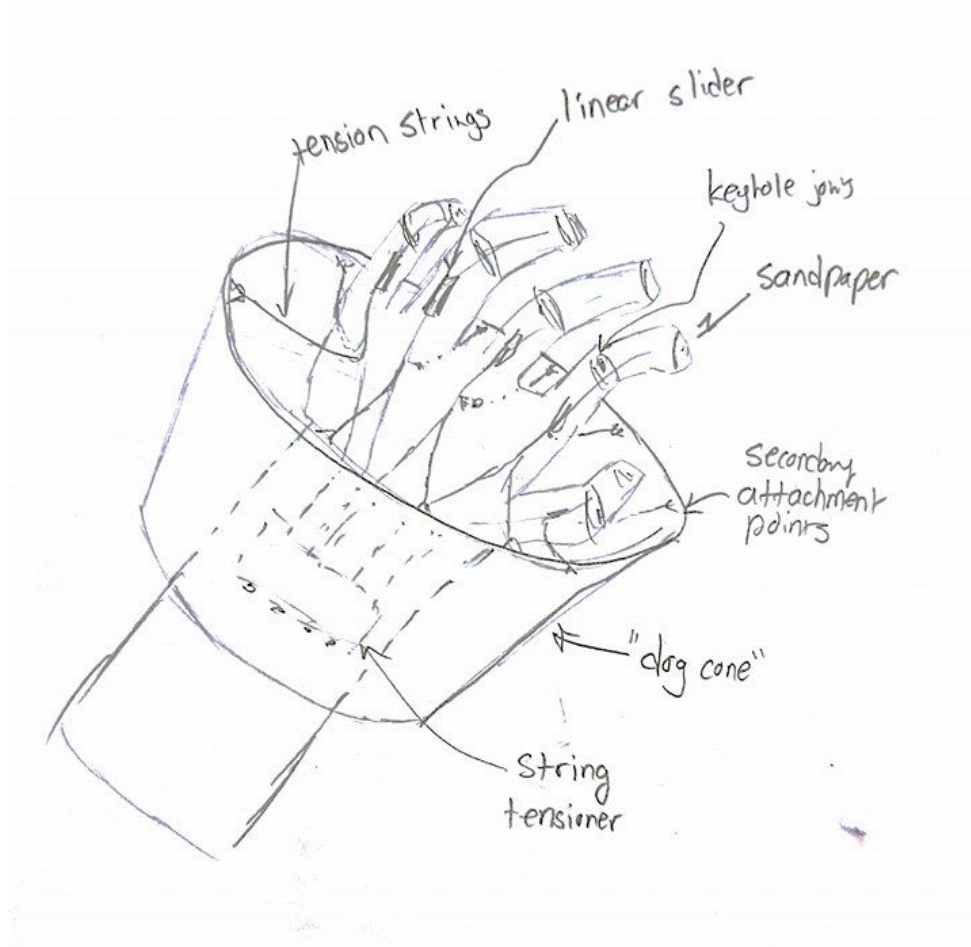

Fig. 26: Dog cone hand design alternative.

4 CONCEPT SELECTION

4.1 CONCEPT SCORING MATRIX

	Safety	Cost of components	Availability of parts	Weight of device	Scalability	Ease of assembly	Durability	Strength of grip	Ease of operation	Row Total	Weight Value	Weight (%)
Safety	1.00	8.00	9.00	5.00	5.00	5.00	8.00	0.50	0.33	41.83	0.24	23.92%
Cost of components	0.13	1.00	3.00	2.00	2.00	2.00	5.00	0.17	0.20	15.50	0.09	8.86%
Availability of parts	0.11	0.33	1.00	0.25	0.20	0.14	1.00	0.33	0.11	3.48	0.02	1.99%
Weight of device	0.20	0.50	4.00	1.00	1.25	2.00	2.00	0.33	0.20	11.48	0.07	6.57%
Scalability	0.20	0.50	5.00	0.80	1.00	0.50	5.00	0.50	0.33	13.83	0.08	7.91%
Ease of assembly	0.20	0.50	7.00	0.50	2.00	1.00	4.00	0.25	0.25	15.70	0.09	8.98%
Durability	0.13	0.20	1.00	0.50	0.20	0.25	1.00	0.13	0.13	3.54	0.02	2.02%
Strength of grip	2.00	6.00	3.00	3.00	2.00	4.00	8.00	1.00	0.50	29.50	0.17	16.87%
Ease of operation	3.00	5.00	9.00	5.00	3.00	4.00	8.00	2.00	1.00	40.00	0.23	22.88%
	Column Total:									174.85	1.00	100%

Table 5: Analytical hierarchy process matrix.







		Alternative Design Concepts											
													
Selection Criterion	Weight (%)	Rating	Weighted	Rating	Weighted	Rating	Weighted	Rating	Weighted	Rating	Weighted	Rating	Weighted
Safety	23.92	5	1.20	5	1.20	1	0.24	1	0.24	4	0.96	3	0.72
Cost of components	8.86	3	0.27	4	0.35	1	0.09	1	0.09	2	0.18	3	0.27
Availability of parts	1.99	3	0.06	4	0.08	1	0.02	1	0.02	3	0.06	3	0.06
Weight of device	6.57	3	0.20	3	0.20	1	0.07	1	0.07	3	0.20	3	0.20
Scalability	7.91	3	0.24	1	0.08	2	0.16	1	0.08	3	0.24	1	0.08
Ease of assembly	8.98	3	0.27	1	0.09	1	0.09	1	0.09	2	0.18	1	0.09
Durability	2.02	3	0.06	3	0.06	4	0.08	3	0.06	3	0.06	3	0.06
Strength of grip	16.87	3	0.51	3	0.51	5	0.84	5	0.84	3	0.51	3	0.51
Ease of operation	22.88	3	0.69	3	0.69	1	0.23	3	0.69	3	0.69	1	0.23
	Total score	3.478		3.249		1.815		2.173		3.061		2.205	
	Rank	1		2		6		5		3		4	

Table 6: Weighted scoring matrix.

4.2 EXPLANATION OF WINNING CONCEPT SCORES

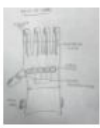
The Dial-up concept was ranked first. This concept was used as the reference in the WSM. It was ranked highest for safety because it is simple mechanically and does not use external power. Despite these facts, it surprisingly was not ranked highest for cost of components. The Gearhead includes the fewest non-3D printed parts, causing it to be the most cost-effective. The Dial-Up is the most scalable, especially if the bolts are 3D printed: then, essentially the strings and elastics would be the only additional components and those do not impact scalability. The Dial-up is a design very similar to open-source hands that have a plethora of assembly instructions and resources available online, leading to its high ranking for ease of assembly. Our group is pleased that our analysis and metrics led us to this design, and we are excited to move forward with it!

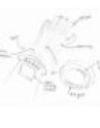
4.3 EXPLANATION OF SECOND-PLACE CONCEPT SCORES

The Gearhead concept was a close second behind the Dial-Up. This design is wrist-activated (not powered) leading to its high scoring on ease of operation. The Gearhead was an appealing design because its activation is directly mechanical. Gears and linkages give direct (and calculable, through gear ratios) translation of wrist movement into hand movement, and do not use any type of pulley or elastic system. This advantage meant that it ranked highly in cost of components and availability of parts since it could theoretically be entirely 3D printed; however, it surprisingly ranked poorly in scalability. This is because the complex gear and linkage network would likely not be conducive to a simple scaling with CAD software. Interfaces would likely be troublesome, not to mention that if some of the gear and linkage network was machined or purchased (which is likely, to increase durability) then all new fittings and components would be necessary for a differently-sized hand. While this design was enticing to pursue from a mechanical engineering standpoint, our group agrees that the Gearhead was not the optimal design.

4.4 EXPLANATION OF THIRD-PLACE CONCEPT SCORES

The Megaman hand was the next most reasonable design to our group, so again this ranking made sense to us. While powered devices were exciting from an electromechanical design standpoint and from a strength perspective, we knew that those designs were too heavy and complicated to serve as the cost-effective prosthetic that is necessary for pediatric patients. The Dog-Cone Hand primarily lost points for complexity, so the next logical design was the Megaman Hand. The unique component of this design is the sliding wrist-mounted bezel which influences grip patterns. This bezel caused a slightly lower safety rating than optimal, because winding up the device rotationally with high string tension could potentially lead to unsafe device failure. Component cost also took a slight hit from reference because it is likely that the bezel would need to be reinforced by metal components. The bezel introduces a challenge in assembly as well, because it is a rotationally sliding piece mounted in the middle of the device. It is likely that the remainder of the wrist gauntlet would need to be broken into separate parts to allow for complete assembly, which could be cumbersome. This design is optimally scalable. Mechanically it is very similar to the Dial-up, with the main differentiating factor being the bezel, which would likely not introduce scaling issues, as it is essentially a ring. Though this Megaman Hand design had a neat mechanical feature in the bezel, especially from a user 'coolness' standpoint, its complexity led us to agree that it was not the best design to move forward with.

4.5 SUMMARY OF EVALUATION RESULTS

Evaluation criteria were weighted relative to each other based on an Analytical Hierarchy Process Matrix, as detailed in the Table 5. The weight percentages generated through this process were generally as expected. As our project is a medical device, safety was weighted highest at 23.92%: if a medical device does not improve health, then it is not successful. Ease of operation was ranked second highest at 22.88%, and this was primarily due to the fact that our unique addition to 3D printed prosthetic hands is a user-operated mechanism. For our project, this criteria was crucial because if the mechanism is too complicated, patients will not utilize it. Our third highest criteria was strength of grip, and this was important because it evaluates the true functionality of a prosthetic hand. The other 6 criteria were weighted similarly, anywhere from 2-9%. Many of these are more pertinent for the device if it were to be mass-produced (scalability, ease of assembly, etc.), which we recognize are important but are likely not a priority for our first design attempt at this problem. The 6 concepts finished according to our Weighted Scoring Matrix (see Table 6). The Dial-Up/Slider finished first, as expected. We felt that this concept was the most feasible, simple, and most closely resembled current successful devices. In second and third were the Gearhead and the Megaman Hand. These two designs were the most similar to the Dial-Up, and did not require external power. The last three finishers (Dog-Cone Hand, Magna Hand, and Robohand), all introduced potentially unnecessary complications: the Dog-Cone Hand included a complex string network, and the Magna Hand and Robohand were externally powered. Our evaluation left us with the concept we were hoping to pursue, which reassured our intuition and excited us moving forward with our design. One tangible thing that we took away was the immense importance of safety in our design: we absolutely need to make sure that safety is a top priority during embodiment and testing. A Design for Safety analysis is imperative.

5 EMBODIMENT & FABRICATION PLAN

5.1 ISOMETRIC DRAWING WITH BILL OF MATERIALS

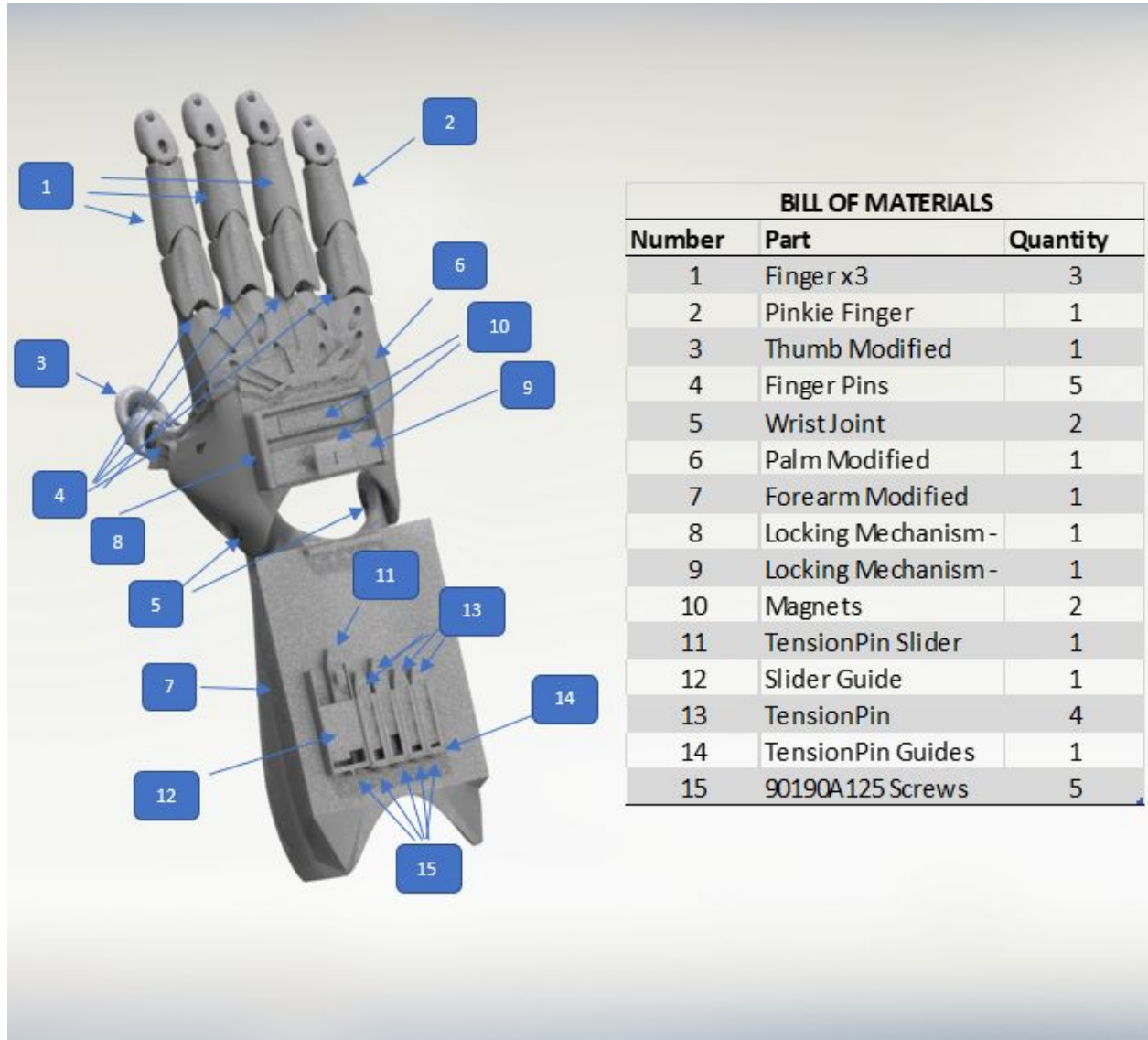

Fig. 27: Isometric drawing with bill of materials.

5.2 EXPLODED VIEW

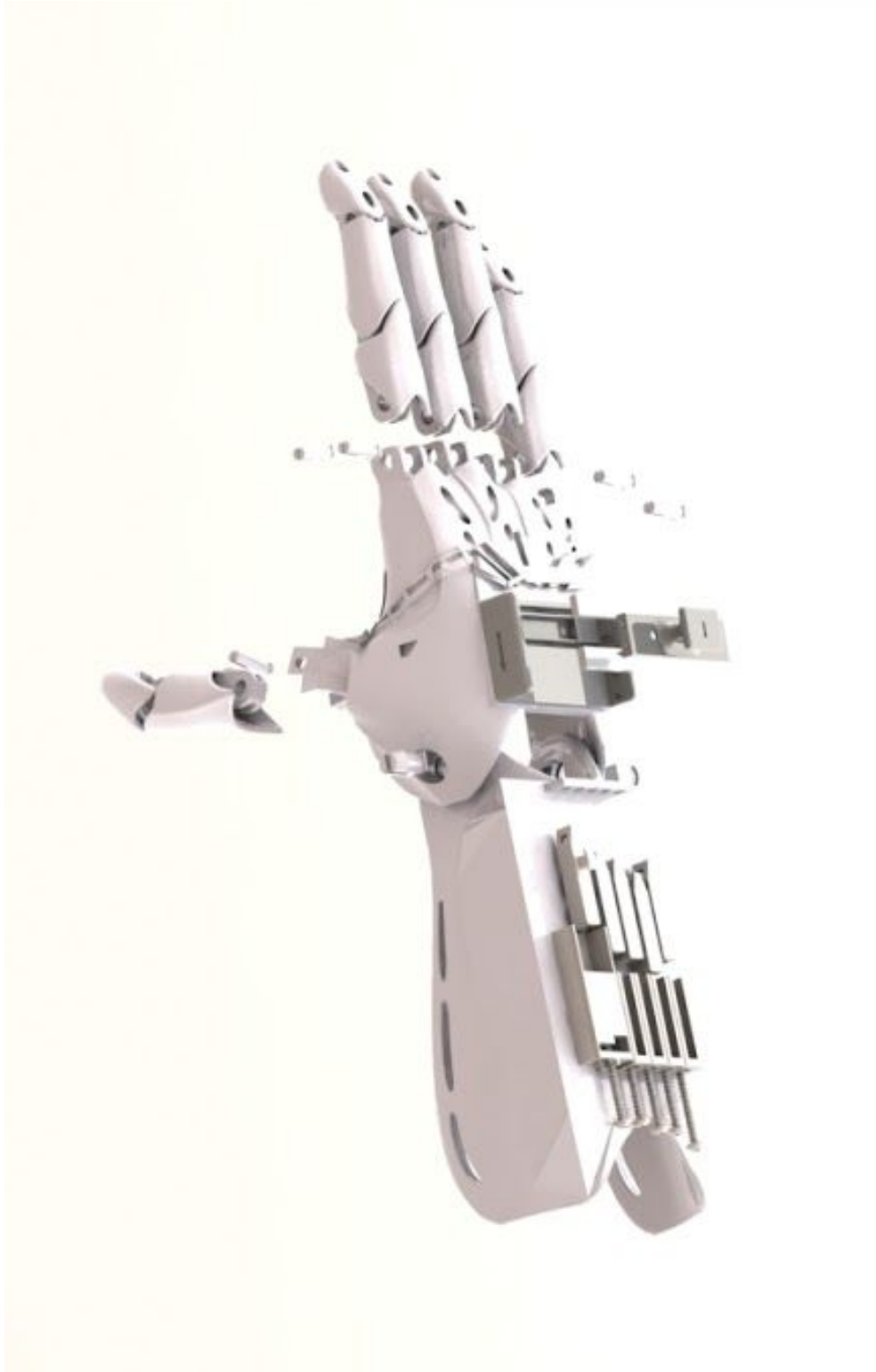

Fig. 28: Exploded view.

5.3 ADDITIONAL VIEWS

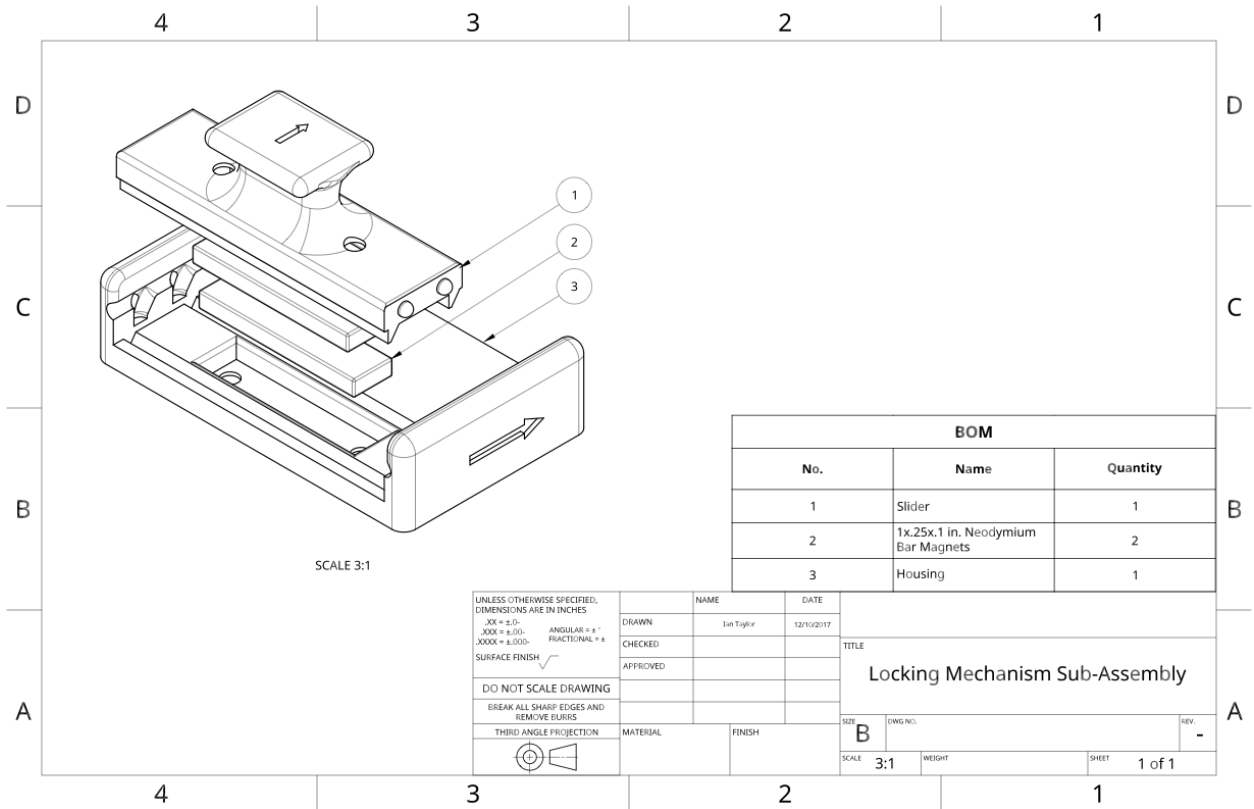

Fig. 29: Locking Mechanism Sub-Assembly CAD Model.

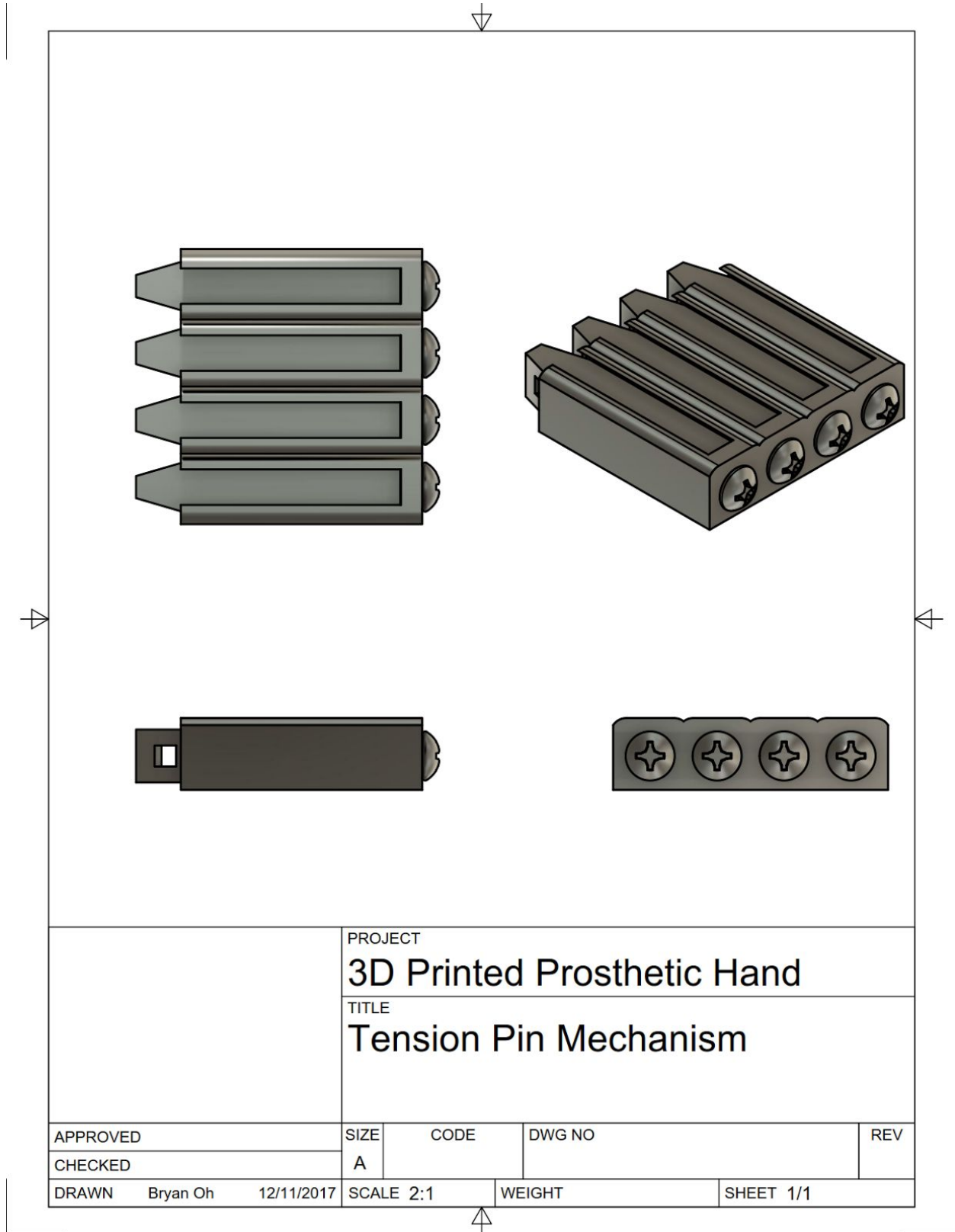

Fig. 30: Tension pin assembly view.

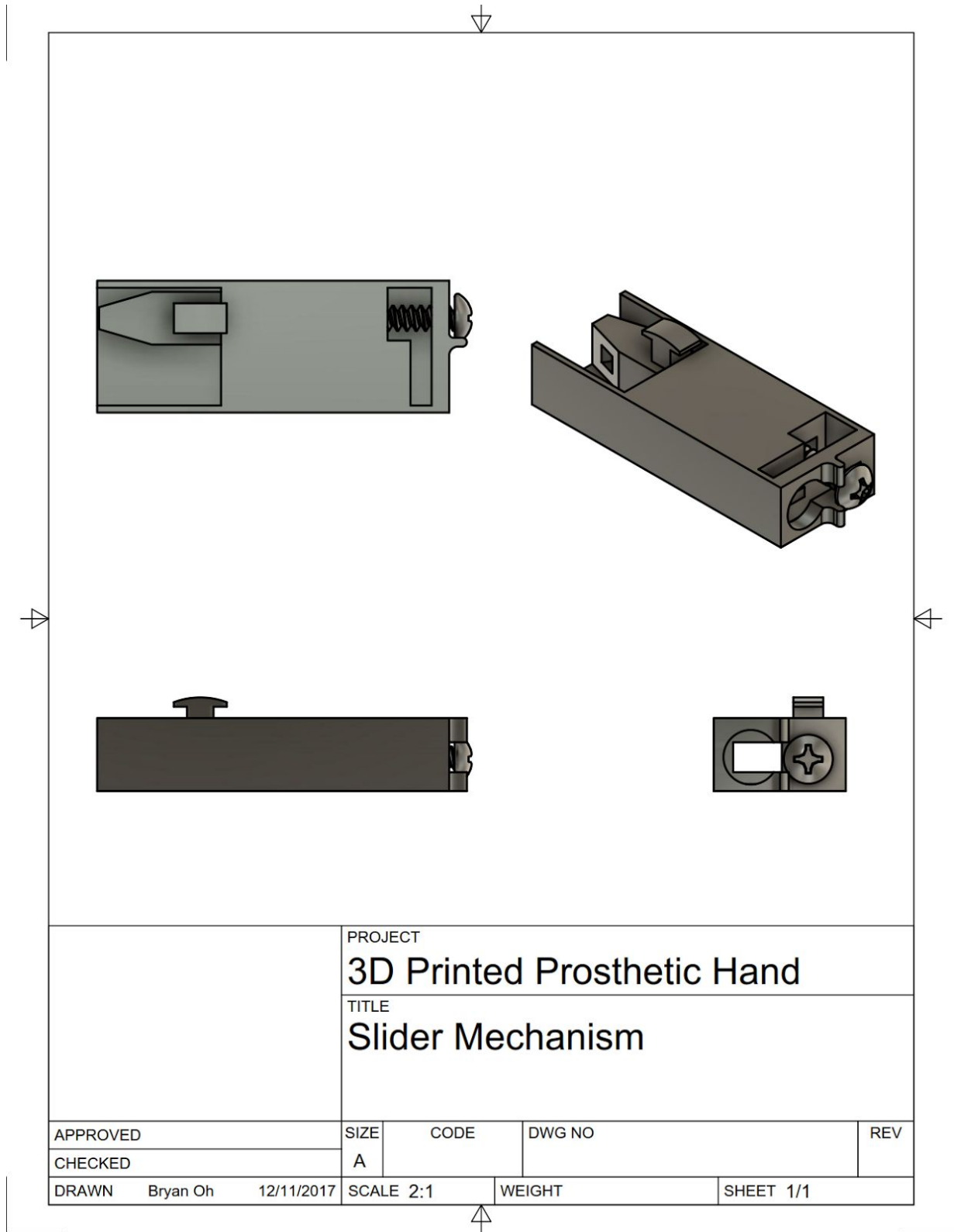

Fig. 31: Slider mechanism assembly view.

6 ENGINEERING ANALYSIS

6.1 ENGINEERING ANALYSIS RESULTS

6.1.1 Motivation

Since the tension pins are responsible for providing tension in the strings that actuate the finger movements, it is imperative that the tension pin does not fracture or fail under high stress and many cycles. By analyzing the stress imparted by the string tied to the end of the tension pin and the interface between the screw head and tension pin base, we can make informed decisions on modeling the pin and base to reduce the probability that the mechanism will fail. We expect to obtain data such as stress fields due to an applied force on our parts and exaggerated theoretical deflections of our parts in response to an applied force. With the information from the stress fields, we can make changes to our model if needed to minimize areas of high stress concentration to reduce the risk of failure. In addition, we can also make non-critical design changes that can reduce the weight or the size of the part if there is low risk that these would impact the survivability of the part.

6.1.2 Summary Statement of the Analysis

A Solidworks SimulationXpress study was conducted on two parts: the tension pin and the tension pin base. The study for the tension pin was conducted to analyze the stress fields resulting from the tension force from the string tied to the end of the pin. The study for the base was conducted to analyze the stress fields resulting from the force of the head of the screw on the base which should be the same as that from the string. The stress can be theoretically calculated using the equation shown: $\sigma = \frac{P}{A}$. However, for more complicated models, this stress analysis is much more involved and SimulationXpress accomplishes this. The deflection in the one-dimensional case can be calculated by the equation shown: $\delta = \frac{PL}{EA}$. Again, this is very simplified and SimulationXpress is able to analyze and predict displacements in multiple dimensions. With SimulationXpress, we were able to analyze our part for stresses and deflections in a clear quantitative and qualitative manner.

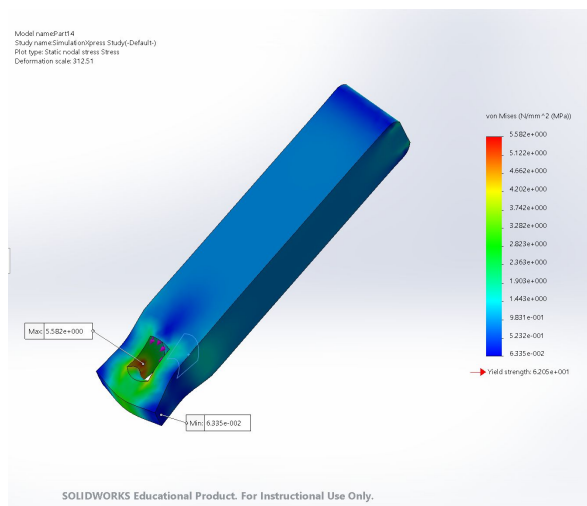

Fig. 32: Solidworks SimulationXpress analysis of tension pin.

6.1.3 Methodology

As mentioned earlier, the analysis was performed via SimulationXpress Study, a tool available for use in Solidworks 2017. The tension pin and base models used in the study are prototypes that have been 3D printed with PLA and tested to ensure functionality.

Tension Pin:

The fixture was defined as the back end of the tension pin where the screw is inserted. The force was defined to act on the curved inside face nearest the end of the tension pin where the string would pull on the tension pin.

Tension Pin Base:

The fixture was defined as the bottom face of the base as that would be secured to the 3D-printed forearm. The force was defined to act on a circular portion of the backside of the base where the screw-head would contact as it is pulled by the tension pin.

Testing:

To determine the amount of tension force acting on the tension pin and base, we measured the tension force of the string when the hand was in its fully-gripped position by securing a spring dynamometer and attaching the string to it. The experimental schematic is shown below. From this experiment, we determined that a force of around 10 N was about the average amount of tension force exerted on the string.



Fig. 33: A spring dynamometer was used to test the tension force.

6.1.4 Results

From the analysis study, we found that no part of both designs ever exceeded the Von Mises yield stress. As expected, the areas of largest stress and deflections were located near thin walls and sharp edges. Thus, possible improvements to these designs could be the addition of fillets to reduce the number of sharp edges and the thickening of walls. Overall, both parts seem to be modeled well and seem to be very capable of handling the stresses resulting from the tension force. Both the stress fields and deflections were as predicted and the study appears to be accurate. It is important to note that the nature of 3D printing causes layer defects since the part is printed layer by layer. The study does not take that into account so the yield stress may be much lower in actuality in certain areas.

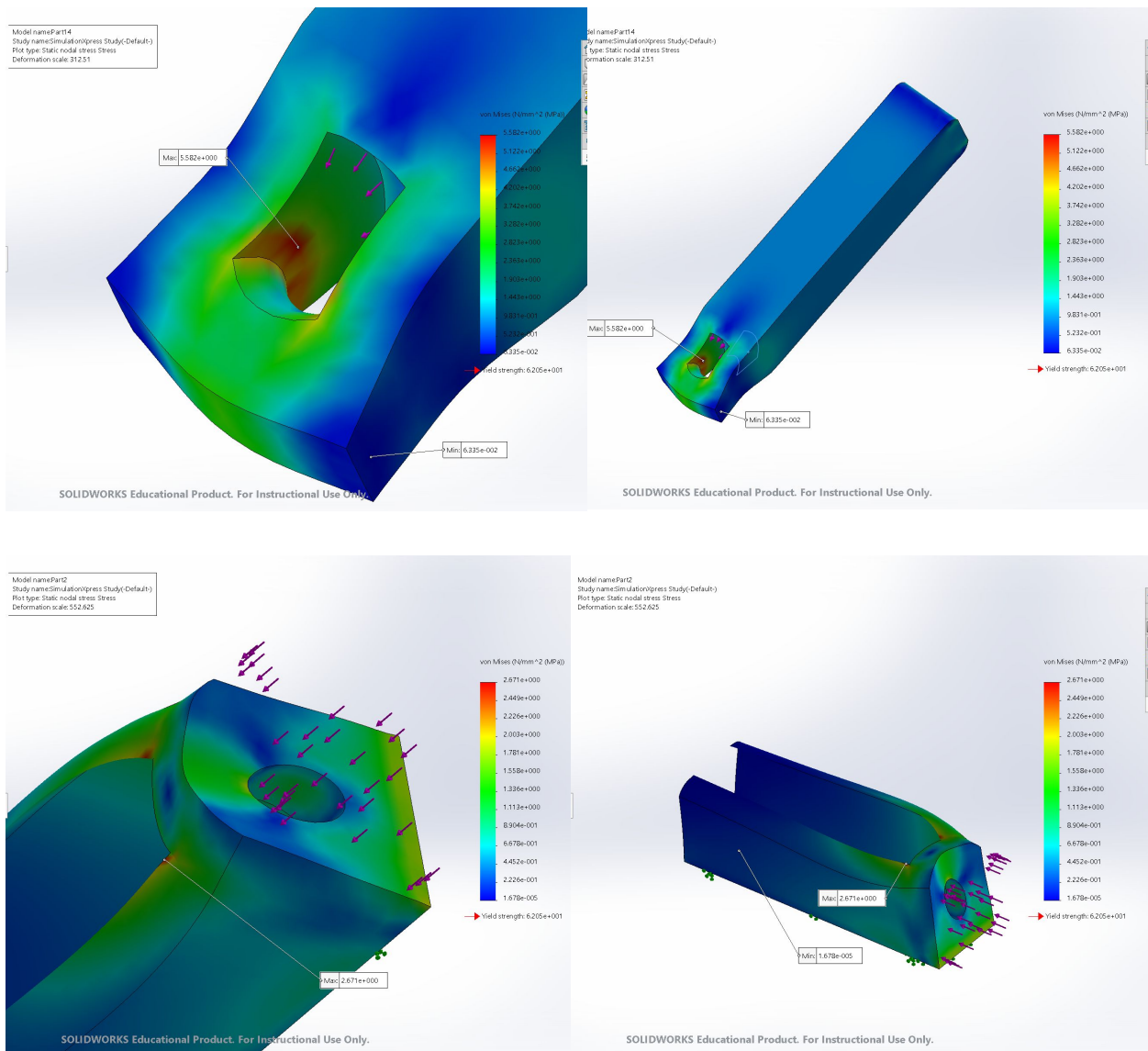

Fig. 34: Solidworks SimulationXpress analysis of tension pin.

6.1.5 Significance

From the simulation results, we decided to try to further reduce stresses on our parts by removing as many sharp edges as possible. For the tension pin, we added fillets to some parts of the outside and all of the interior swept cut where the string is fixed to. As a result, we reduced the maximum Von Mises stress from 5.582 MPa to 2.159 MPa which is a considerable reduction in stress. Thus, this shows that it is definitely worthwhile for us to remove as many sharp edges as possible and to ensure that regions of high stress are thick enough to handle the stress. In terms of material selection, PLA is a good choice for us to use due to its reasonable strength and availability. In this particular case, the thickness of the walls seem to be adequate and does not look like they will need any modification.

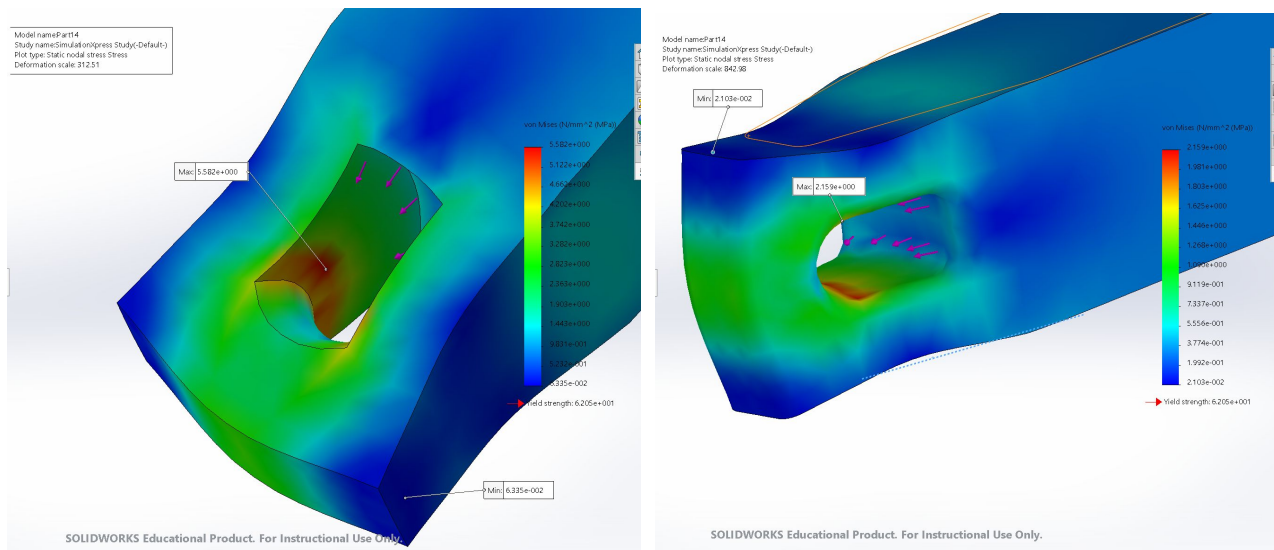

Fig. 35: Solidworks SimulationXpress analysis of tension pin.

6.2 PRODUCT RISK ASSESSMENT

6.2.1 Risk Identification

Risk Name: Locking mechanism failure

Description: The locking mechanism could lose its hold on the tensioned cord during a locked grip. This failure could lead to a dropped object, potentially damaging the object and/or the user's feet. This failure mode is more likely when the user is attempting an especially tight grip, as there is more force pulling the cord. This failure could also occur if the user bumps the back of the palm into something during a locked grip, moving the locking mechanism and releasing its hold.

Impact = 4: Locking mechanism failure is impactful because the locking mechanism will be used primarily with heavier objects (where sustained actuation is not preferred). These heavier objects pose a higher risk of damaging the user's feet.

Likelihood = 3: The locking mechanism has a chance of failure because our design is attempting to balance damaging the string with holding it in place, somewhat compromising the strongest clamping methods to maintain the integrity of the strings. Additionally, for some objects and grips, the strings will have a high amount of tension.

Risk Name: Cord release

Description: One or more of the tension cords, the main mechanism for device function, could snap or become undone. This failure could lead to a dropped object, potentially damaging the object and/or the user's feet. Cord release also renders that finger useless, as it can no longer be actuated by the wrist, and must be repaired or replaced. This failure could result from tension (increased when holding heavy objects, or fatigue stress), from friction as it is rubbed against structures in the device, from exposed portions catching an external object (more likely when there is slack during a resting position), from being cut by an external object, or from connection points at the fingertips or tension pins coming loose.

Impact = 3: Cord release is impactful because it will release the grip and potentially drop whatever object the user is holding onto their feet. However, it is not particularly likely that all the cords will fail, and it is also unlikely that a single string would cause the device to drop an object.

Likelihood = 3: Cord release has a chance of failure because the cords bear significant loading and have a number of possible failure points (as described above).

Risk Name: Elastic release

Description: One or both elastics could snap or become undone. This failure would disable the resting open hand position and allow fingers to float without tension. It could also project an elastic segment

from the device, potentially hitting the user. This failure could result from tension (increased if they are installed tightly, also potentially from fatigue stress), from friction as it is rubbed against structures in the device, from exposed portions being cut by an external object, or from connection points at the fingertips coming loose.

Impact = 2: Elastic failure is not very impactful because it does not release a grip, but simply disables the preferred hand-open resting position. The most impactful failure mode would be for a loose string to shoot back at the user, but this is very unlikely because the elastics are mostly held in the device with PLA supports.

Likelihood = 2: Elastic failure is generally unlikely because it is difficult to over-tighten them, and the elastic holes are small enough that normal knots will keep them from coming loose.

Risk Name: Tension pin failure

Description: One or more of the tension pins could break or come loose at their string or screw interface. This failure could lead to a dropped object, potentially damaging the object and/or the user's feet. Tension pin failure also render that finger useless, as it can no longer be actuated by the wrist, and must be repaired or replaced. That string can also no longer be tensioned. At the string end, this failure could result from tension (increased when holding heavy objects, or fatigue stress), causing the front of the pin to snap. At the screw end, the PLA threads could strip as a result of tension or fatigue and the pin could come loose.

Impact = 3: Tension pin failure is impactful because it will release the grip and potentially drop whatever object the user is holding onto their feet. However, it is not particularly likely that all the tension pins will fail, and it is also unlikely that a single tension pin would cause the device to drop an object.

Likelihood = 2: The tension pins have been analyzed and optimized to not fail under expected loads on the string end, and they have been designed long enough such that a satisfactory amount of threads area always biting the internal PLA.

Risk Name: Finger failure

Description: One or more of the PLA fingers could fracture and break. This failure could lead to a dropped object, potentially damaging the object and/or the user's feet. Finger failure would necessitate part replacement. This failure could result from stresses provided by the strings or elastics, or from an impulse caused by dropping the device or hitting it against an external object. This failure mode is more likely to occur at thinner portions of the fingers, such as the joint flanges.

Impact = 3: Finger failure is impactful because it will release the grip and potentially drop whatever object the user is holding onto their feet. However, it is not particularly likely that all the fingers will fail, and it is also unlikely that a single finger would cause the device to drop an object.

Likelihood = 2: The loads during normal operation of the device are not expected to lead to failure due to the amount of material at joints. The most likely failure mode would be if the user were to bump the fingers into something, but this is unlikely because the user would ideally treat this device like an actual hand.

Risk Name: Strap failure

Description: The Velcro strap restraining the partial hand could fail. This failure would render the device useless, as it is necessary to maintain rigid limb/device contact for actuation. This failure could lead to a dropped device, potentially damaging the device itself, any object the device was grasping, or the user's feet. One failure mode could be the Velcro itself comes loose, potentially a result of over-tightening and user movement or an external object pulling on it. Another failure mode could be a snapping of the Velcro, potentially a result of over-tightening but more likely from an external object cutting it. A third failure mode could be that the PLA slots through which the Velcro loops could break.

Impact = 4: For this device, a Velcro strap failure would be very impactful because it has the potential to break any aspect of the device, as well as drop the entire device and whatever the device is holding, on the user's feet.

Likelihood = 1: Velcro failure is very unlikely because it is user-tightened, has a large contact area on the patient's arm, and has secure attachment points to the device.

6.2.2 Risk Heat Map

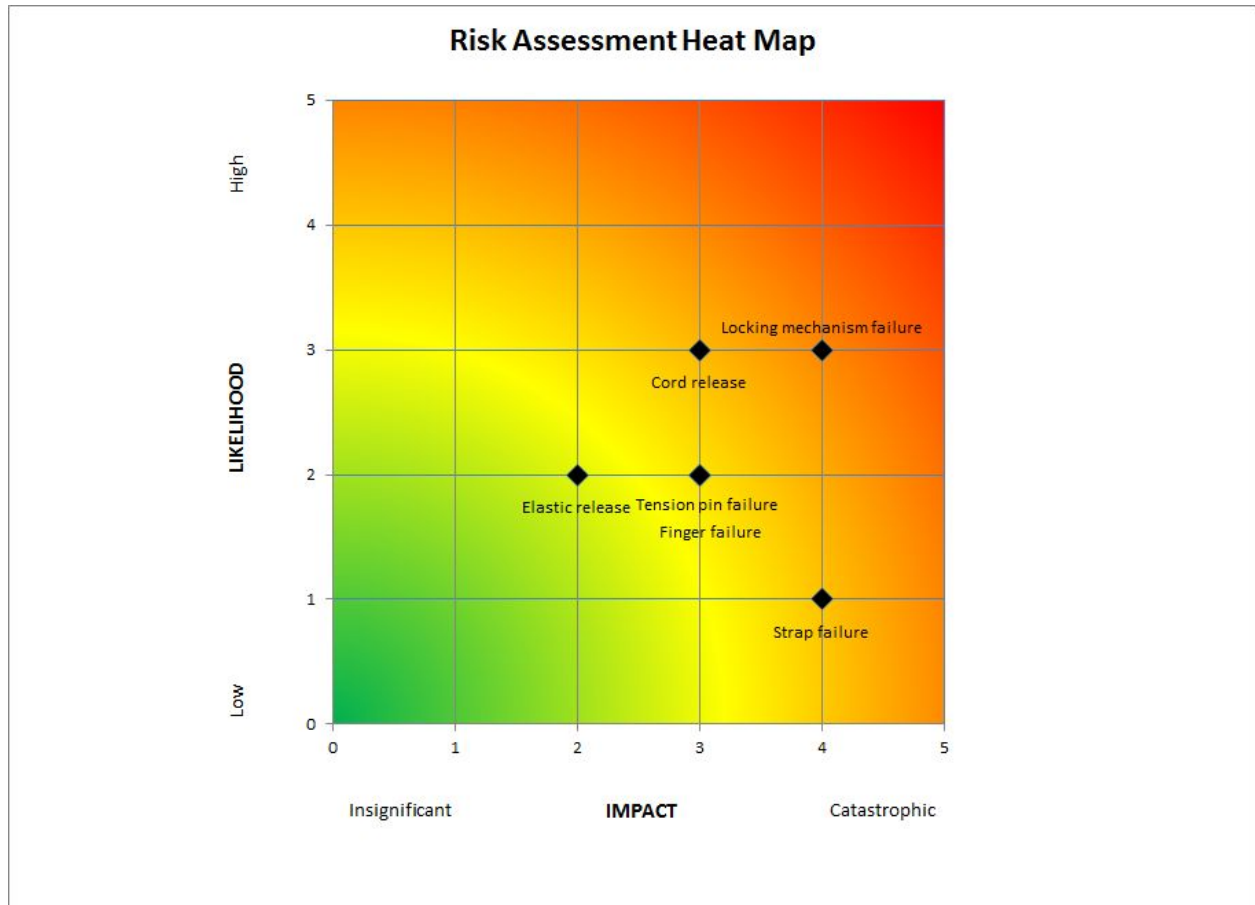

Fig. 36: Risk assessment heat map.

6.2.3 Risk Prioritization

These results are generally expected. The failure modes related to the strings all have similar consequences, and as such have similar placements near the center of the heat map. None of the failures have particularly high likelihoods, as we are confident in our design and our planning. The two highest impact risks have very different likelihoods, and the locking mechanism failure is a priority we are continuing to invest significant time into.

7 DESIGN DOCUMENTATION

7.1 PERFORMANCE GOALS

1. The hand must pick up and put down a Contigo Jackson water bottle 30 times without breaking/malfunctioning, using the fist grip.
2. The hand must pick up and put down a standard number 2 Ticonderoga hexagonal pencil 30 times without breaking/malfunctioning, using the 3 finger chuck grip.
3. The hand must switch between the fist and 3 finger chuck grip 30 times without without breaking/malfunctioning.
4. The hand switches must occur in an average of under 5 seconds.
5. The hand must lock and unlock its grip 30 times without without breaking/malfunctioning.

7.2 WORKING PROTOTYPE DEMONSTRATION

7.2.1 Performance Evaluation

The initial working prototype used in the demonstration was able to complete goals one through four successfully. Unfortunately at the time of the demonstration the magnets used in the locking mechanism sub-assembly were not glued into the assembly. Because the magnets are essential to the locking capabilities of the mechanism the fifth goal could not be tested at the time of demonstration. Even so, once the prototype was updated and the magnets were glued in all of the goals were easily achieved as can be seen in the final prototype demonstration video found in the link below. There were many difficulties in modifying the prototype to achieve all of the goals. The main issues being that the locking mechanism was not strong enough to keep the strings from moving and the grip changing slider was very finicky and only had to be moved a very small increment to change the grip. Both of these issues were solved by a simple iterative design process where we continuously updated the models to try and address the problems, then printed and tested the models. This process was repeated until we were able to achieve the goals set out in our initial performance goal statement.

7.2.2 Working Prototype – Video Link

<https://youtu.be/A7u0qTW2gks>

7.2.3 Working Prototype – Additional Photos

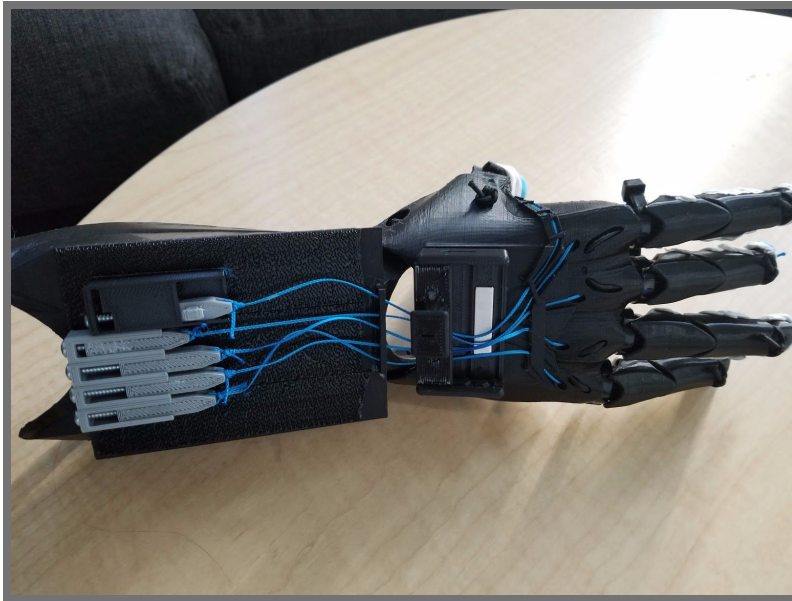

Fig. 37: A top view of working prototype.



Fig. 38: A bottom view of the working prototype.

8 DISCUSSION

8.1 DESIGN FOR MANUFACTURING – PART REDESIGN FOR INJECTION MOLDING

8.1.1 Draft Analysis Results

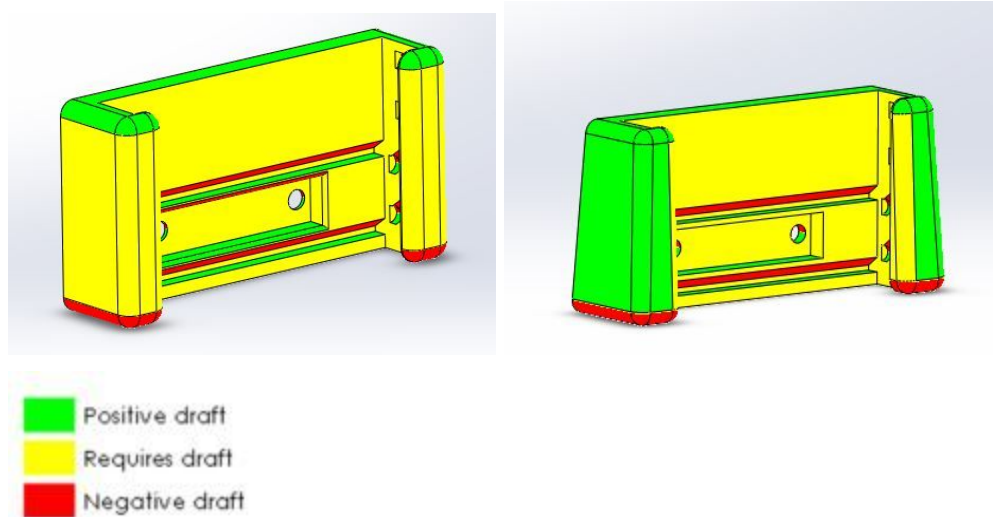

Fig. 39: Pre/post modification images and legend.

8.1.2 Explanation of Design Changes

The part that was analyzed and changed was the locking mechanism base. As can be seen from the photos there is a significant portion of the mechanism that has vertical sidewalls, some which can and cannot be modified. The back and side faces were selected to be drafted because the formation and appearance of them is purely aesthetic and non-functional, thus the draft can be applied without worry of altering the mechanism. The sliding and internal faces were not drafted for the same reason, if they were given a draft they would not function properly.

8.2 DESIGN FOR USABILITY – EFFECT OF IMPAIRMENTS ON USABILITY

8.2.1 Vision

A vision-impaired user may have difficulty seeing and distinguishing the interactive features of our device. For example, the locking mechanism and the slider are both printed in the same PLA as the rest of the hand. We could print these in a different color filament to make them easily-identifiable, and thus increase the usability of the device. Additionally, the tension screw heads are very small and may be hard to operate for a visually impaired person. We could address this issue by scaling up the tension pin and screw complex to make them easier to see and operate.

8.2.2 Hearing

On some of the mechanisms of our device, auditory stimulus is a complementary component of realizing when an action has been completed. For example, the locking mechanism and slider both click into place when they are engaged, and a user with a hearing impairment may not be able hear this cue. However, the visual indication that the mechanism has been engaged is much easier to notice and intuitive. Thus, a hearing impairment would not influence the usability of our device.

8.2.3 Physical

Our device is designed for a specific type of physical impairment (transradial amputation / congenital defect), but there are other physical impairments that could influence the usability of the device. For one, the user may be weak, so we want to make sure that the standard operation of the device is not force-intensive. Our tension pins ensure that device actuation is calibrated to the user, but the locking mechanism and switching mechanisms are not alterable. The locking mechanism locking force and the slider's translational movement have been experimentally determined and designed for, but the user interface for these mechanisms could be altered. We could create alternate handles for users across the aesthetic preference vs. functionality preference spectrum to choose from to fit their needs.

8.2.4 Language

Our device is intended to be a design available to global patients. We do not want the assembly of our device to hinge on the comprehension of a technical manual, for both language impaired individuals and otherwise. As such, we need to design our device to have an intuitive assembly process. We could remove extraneous features and grooves on the model and ensure that it is clearly indicated where specific parts go. We could design easily-distinguishable parts (such as each finger having a small marking similar to the rest of the components of that specific finger), as well as design pieces that can only be assembled in the correct orientation, such as channels and flanges in the tension pins that only allow the correct orientation.

8.3 OVERALL EXPERIENCE

8.3.1 Does your final project result align with the initial project description?

The final project does align with our initial project description. Our primary initial focus was grip switching between the fist and three-finger chuck, which we did pursue and achieve. Our main deviation from the initial description is that we identified a locking mechanism as another important design avenue to pursue.

8.3.2 Was the project more or less difficult than you had expected?

Overall, the project was as difficult as expected. We knew that our project was going to require lots of prototyping and printing, but that was an advantage because two of our group members owned personal 3d printers. One area that was more difficult than we were expecting was pinch grip precision. It is such a delicate grip, where finger tolerances, tension line tolerances, and contact material hugely influence the success of the grip. Attaining a reliable pinch grip required a lot of post-print modifications to the prototype.

8.3.3 In what ways do you wish your final prototype would have performed better?

We wished our prototype could have more easily achieved our pinch grip goal. Picking up a pencil was a more challenging task than we anticipated (as is evident in our prototype video), and we wished that putty did not have to play as much a role as it had to. If we had recognized the pinch grip issue earlier, we ideally would have invested more time in finding a more appropriate grip material, which was easy to apply and durable.

8.3.4 Was your group missing any critical information when you evaluated concepts?

Two things were not given enough attention during concept evaluation. First, we had not realized the true size and importance of the locking mechanism yet, and may have altered concepts accordingly. We also had not yet realized that all the open-source designs were not going to have accompanying SolidWorks files, and that we would have to directly edit the stl's using different software. This knowledge may have led us to chose a design with fewer required base model modifications.

8.3.5 Were there additional engineering analyses that could have helped guide your design?

One engineering analysis that could have helped our design was a dynamic analysis of the fingers. We could have calculated exactly how we needed to orient the thumb in order to achieve the desired grips, rather than estimating and using trial and error. Additionally, a failure mode analysis of the fingers or strings would have been useful. Simulating those bodies and loads would be challenging, but worthwhile so that we could analyze the worst case failure scenario as well as the most common failure scenario, and design around both.

8.3.6 How did you identify your most relevant codes and standards and how they influence revision of the design?

Due to the cost of prosthesis standards, we utilized a previously-purchased lower-limb prosthesis standard. The information we chose to use related to failure modes, but due to time constraints we were not able to perform the intended full-device failure mode analysis that the standard would have assisted with.

8.3.7 What ethical considerations (from the Engineering Ethics and Design for Environment seminar) are relevant to your device? How could these considerations be addressed?

Plastic (PLA) is wasteful and harmful to the environment, and since our device is designed around a quick turnover rate (children are meant to print new ones as they grow) this device has the potential to be very environmentally unfriendly. One solution to this problem would be a system where old prosthetics could be recycled and used by other children of similar size.

8.3.8 On which part(s) of the design process should your group have spent more time? Which parts required less time?

We should have spent more time on prototype testing. We did a lot of work on subsystem design, but our full prototype was assembled later in the process than we would have liked, which did not allow for much system-level testing. For our group, less time could have been spent on concept generation. After some preliminary discussions, we all had a pretty clear image in mind of what concept we wanted to pursue. We then could have spent extra time with prototype embodiment.

8.3.9 Was there a task on your Gantt chart that was much harder than expected? Were there any that were much easier?

Part selection and ordering was harder than we expected. We had anticipated very few parts (since the device is primarily 3d printed) but it quickly became apparent that we would need to experiment with materials to properly design novel mechanisms. Dividing up our CAD work was much easier than expected, as we quickly settled into our components of the project.

8.3.10 Was there a component of your prototype that was significantly easier or harder to make/assemble than you expected?

Stringing and then tensioning the hand proved to be a difficult task. Tying consistent, well-placed, and strong knots (and untying them when appropriate) was tedious. Our final prototype had a second redundancy with the grip tape, such that if the knot was not tied with the correct placement the hand could still be appropriately tensioned.

8.3.11 If your budget were increased to 10x its original amount, would your approach have changed? If so, in what specific ways?

Our approach would not have changed, because a primary purpose of this type of medical device is cost-effectiveness. Purchasing numerous adult prostheses is expensive, and that is a significant reason why 3d printed devices are appealing- if our devices used expensive materials, they would not be effective in the same niche.

8.3.12 If you were able to take the course again with the same project and group, what would you have done differently the second time around?

If we were to do this again, we would choose our project sooner- our first month of class was spent pursuing a different project. Additionally, we would spend more time initially playing with and understanding the current mechanisms before launching into designing. Had we had a greater understanding of how our base model worked, we would have been able to interface with it much easier. For example, we realized later in the design process that our locking mechanism was not going to also lock the thumb, which was a crucial oversight.

8.3.13 Were your team member's skills complementary?

Our skills were very complementary. We had a great mix of CAD and stl-editing skills, project management, prosthetic knowledge, organization, and technical skills. We worked very effectively together.

8.3.14 Was any needed skill missing from the group?

One skill that could have been useful was failure analysis. If we had a member with strong FEA skills, we may have been able to perform a true failure analysis of our device's integrity under its unique loading.

8.3.15 Has the project enhanced your design skills?

The project has enhanced our design skills through our knowledge of the holistic design process. We can now understand (through experience) the value and importance of each step, and can approach design problems more systematically and confidently.

8.3.16 Would you now feel more comfortable accepting a design project assignment at a job?

Having completed this course, we absolutely would feel more comfortable accepting a design project assignment at a job. We now have a firm understanding of the general process, and have design process intuition that would be invaluable to apply to all flavors of design assignments.

8.3.17 Are there projects you would attempt now that you would not have attempted before?

We would attempt wearable design challenges much more confidently. These devices have unique design considerations that we now possess important experience and intuition about.

9 APPENDIX A - PARTS LIST

MEMS 411 Group D: 3D-Printed Prosthetic Hand Cost Accounting

Qty	Part	Source Link	Supplier Part Num	Color, TPI, other p	Unit price	Tax %	Tax (\$0.00 if t	Shipping	Quantity	Total price
0	Budget				\$ 230.40		\$ -	\$ -	1	\$ 230.40
1	Velcro straps	Home Depot	75907904401		\$ (5.90)	0.088048	\$ (1.00)	\$ -	2	\$ (12.98)
2	Liquid tape	Home Depot	71247841046		\$ (0.98)	0.088048	\$ (0.62)	\$ -	1	\$ (7.00)
3	Silicone	Home Depot	77027005004		\$ (3.98)	0.088048	\$ (0.71)	\$ -	2	\$ (8.07)
4	Nitrile gloves	Home Depot	062909291288		\$ (2.48)	0.088048	\$ (0.22)	\$ -	1	\$ (2.70)
5	Friction tape	Home Depot	51131034075		\$ (2.97)	0.088048	\$ (0.20)	\$ -	1	\$ (3.23)
6	Latex gripper gloves	Home Depot	062909350039		\$ (4.47)	0.088048	\$ (0.40)	\$ -	1	\$ (4.87)
7	Plastic putty knife	Home Depot	820909082019		\$ (0.98)	0.088048	\$ (0.09)	\$ -	1	\$ (1.07)
8	Neodymium magnets	Home Depot	95421070459		\$ (3.98)	0.088048	\$ (0.35)	\$ -	1	\$ (4.33)
9	Loctite super glue (ultra gel)	Home Depot	79340060076		\$ (4.47)	0.088048	\$ (0.40)	\$ -	1	\$ (4.87)
10	Loctite super glue (threadlocker)	Home Depot	79340242005		\$ (0.47)	0.088048	\$ (0.37)	\$ -	1	\$ (7.04)
11	Stretchy cord	Michael's	725879200437		\$ (2.99)	0.100604	\$ (0.30)	\$ -	1	\$ (3.29)
12	Foam sheet	Michael's	400100241097		\$ (0.99)	0.100604	\$ (0.20)	\$ -	2	\$ (2.18)
13	4 x 3/4 screws	https://www.mcmaster.com/#90190a113/=19z1afd	90190A113		\$ (2.68)	0.000000	\$ -	\$ -	1	\$ (2.68)
14	Bar Magnets	https://www.mcmaster.com/#5848k08/=1a7vf8a	5848K08		\$ (6.00)	0.000000	\$ -	\$ 6.01	4	\$ (30.01)
15	Hatchbox PLA Filament	https://www.amazon.com/gp/product/B00J0ECR3I/ref=oh_aui_detailpage_o05_s007ie=UTF8&pssc=1	NA	Black, 1.75mm	\$ (22.99)	0.043541	\$ (2.09)	\$ -	2	\$ (48.07)
16	Elastic Cord	https://www.amazon.com/gp/product/B071WJF03N/ref=oh_aui_detailpage_o06_s007ie=UTF8&pssc=1	NA	Black	\$ (11.99)	0.043541	\$ (0.55)	\$ -	1	\$ (12.54)
17	Micro Cord	https://www.amazon.com/gp/product/B073FML3J5/ref=oh_aui_detailpage_o04_s007ie=UTF8&pssc=1	NA	Citrus Aspire	\$ (5.99)	0.000000	\$ -	\$ -	1	\$ (5.99)
18	Needle Nose Plier	https://www.amazon.com/gp/product/B0001W30Y/ref=oh_aui_detailpage_o05_s007ie=UTF8&pssc=1	NA	1-Pack	\$ (6.25)	0.038168	\$ (0.24)	\$ -	1	\$ (6.49)
19	Nano Cord	https://www.amazon.com/gp/product/B00NWP3L55/ref=oh_aui_detailpage_o05_s007ie=UTF8&pssc=1	NA	Blue	\$ (8.33)	0.038168	\$ (0.32)	\$ -	1	\$ (8.05)
20	Super Glue	https://www.amazon.com/gp/product/B01A7AV0KA/ref=oh_aui_detailpage_o05_s007ie=UTF8&pssc=1	NA	1 Pack	\$ (4.34)	0.038168	\$ (0.17)	\$ -	1	\$ (4.51)
21	Super Glue Gel	https://www.amazon.com/gp/product/B000AAUAX8/ref=oh_aui_detailpage_o05_s007ie=UTF8&pssc=1	NA	1 Pack	\$ (5.80)	0.038168	\$ (0.22)	\$ -	1	\$ (6.02)
22	4 x 1 in. Screws	Home Depot	NA		\$ (3.72)	0.101440	\$ (0.38)	\$ -	1	\$ (4.10)
23	Neodymium magnets	Home Depot	NA		\$ (3.98)	0.101440	\$ (0.40)	\$ -	1	\$ (4.38)
24	Assorted Springs	Home Depot	NA		\$ (4.37)	0.101440	\$ (0.44)	\$ -	1	\$ (4.81)
25	Springs	Home Depot	NA		\$ (3.21)	0.101440	\$ (0.33)	\$ -	1	\$ (3.54)
26	M2 Tapping Screw Eye Hook	https://www.amazon.com/gp/product/B01MY8PQDL/ref=oh_aui_detailpage_o02_s007ie=UTF8&pssc=1	NA		\$ (4.99)	0.000000	\$ -	\$ -	1	\$ (4.99)
27	M4 Tapping Screw Eye Hook	https://www.amazon.com/gp/product/B01MDQWRL7/ref=oh_aui_detailpage_o02_s007ie=UTF8&pssc=1	NA		\$ (4.98)	0.000000	\$ -	\$ -	1	\$ (4.98)
28	Dynamometer 50N	https://www.amazon.com/gp/product/B00B3F1PSU/ref=oh_aui_detailpage_o01_s007ie=UTF8&pssc=1	NA		\$ (10.52)	0.000000	\$ -	\$ -	1	\$ (10.52)
29	Loctite Fun-Tak	https://www.amazon.com/gp/product/B001F3ZPWJ/ref=oh_aui_detailpage_o00_s007ie=UTF8&pssc=1			\$ (4.80)	0.00	\$ (0.28)	\$ -	1	\$ (5.14)
	Total Budget Left									\$ 0.17

Table 7: Cost accounting table.

10 APPENDIX B - CAD MODELS

For additional CAD models, see Open Scholarship downloads. All the following CAD models with the exception of the magnet are designed to be manufactured using an FDM printer using PLA plastic.

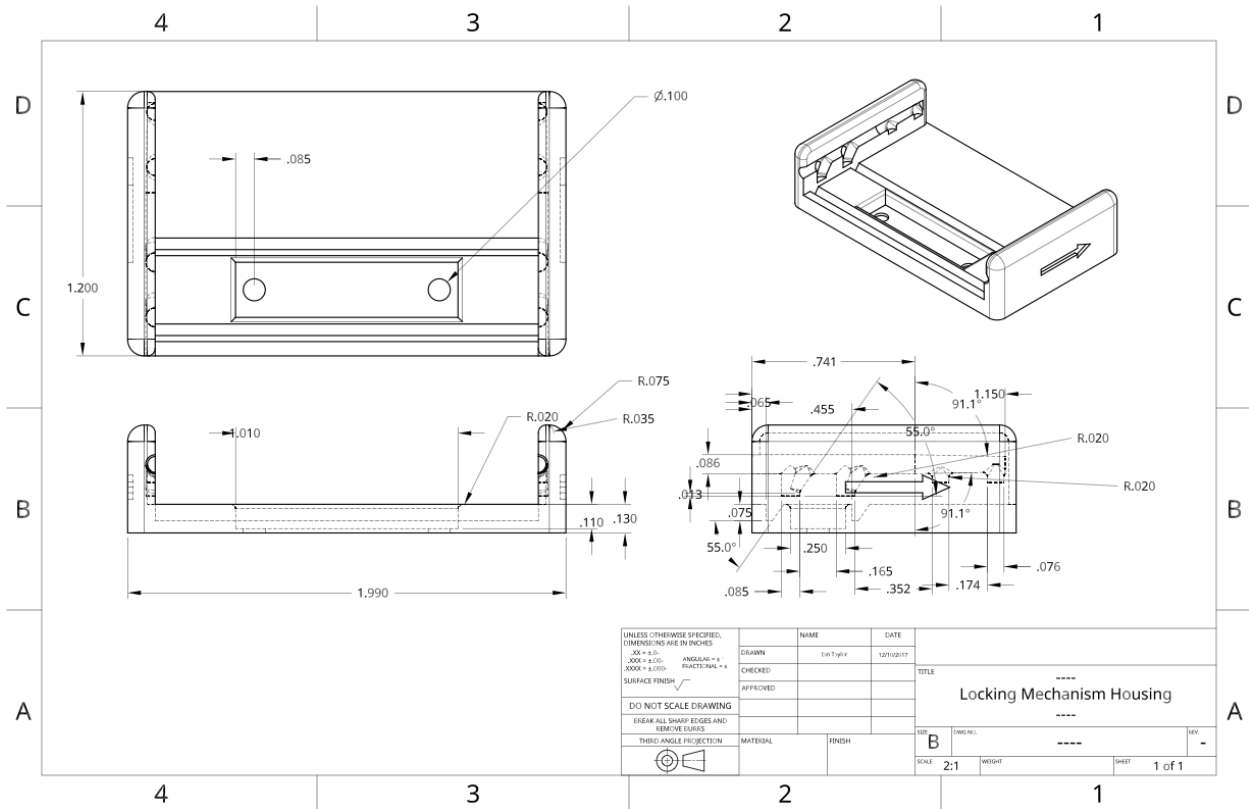

Fig. 40: Locking mechanism housing CAD model.

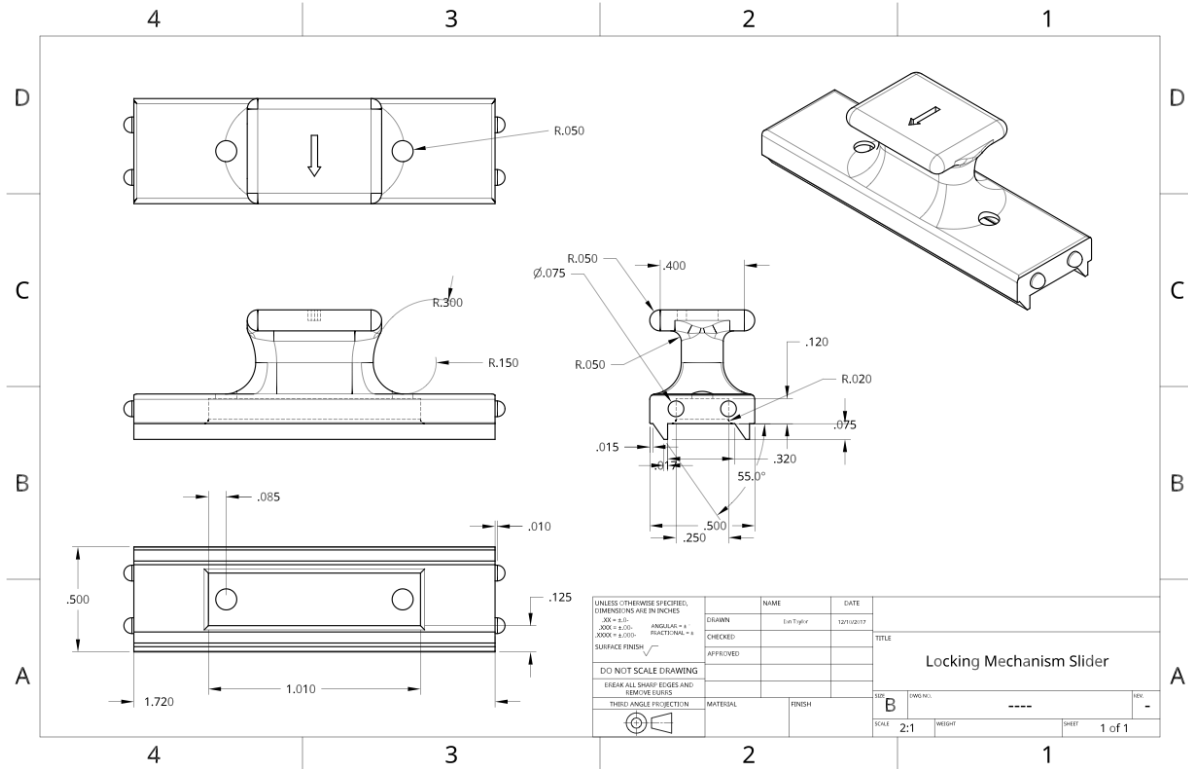

Fig. 41: Locking mechanism slider CAD model.

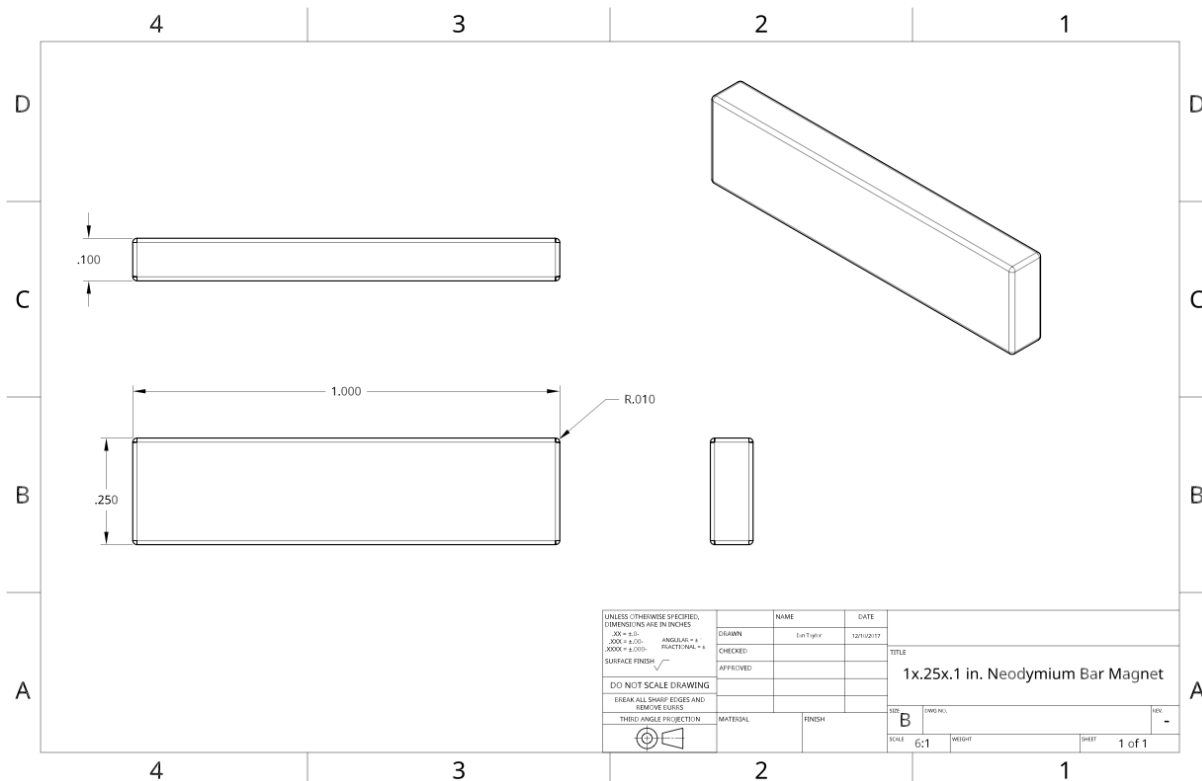

Fig. 42: Locking mechanism neodymium bar magnet CAD model.

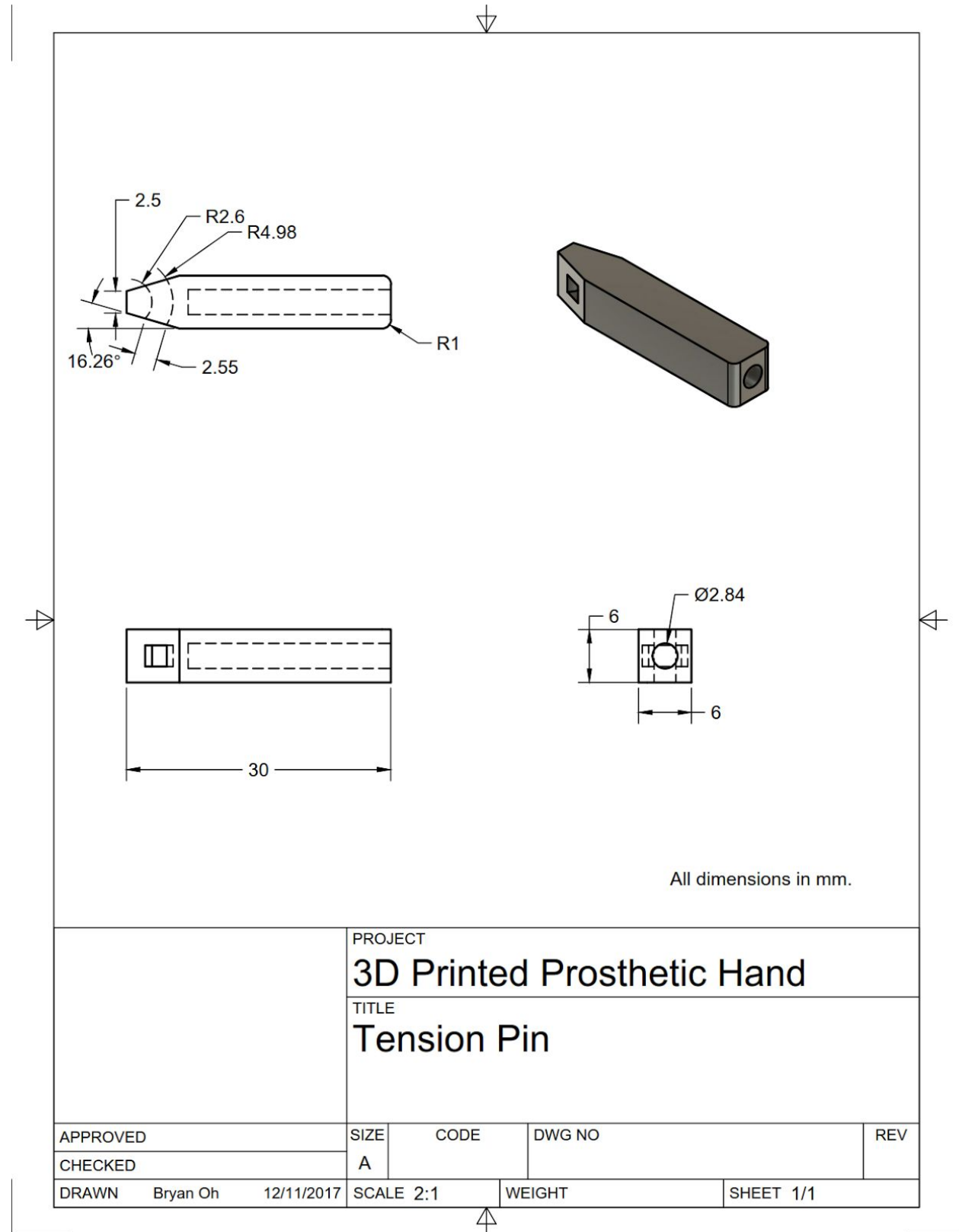

Fig. 43: Tension pin CAD model.

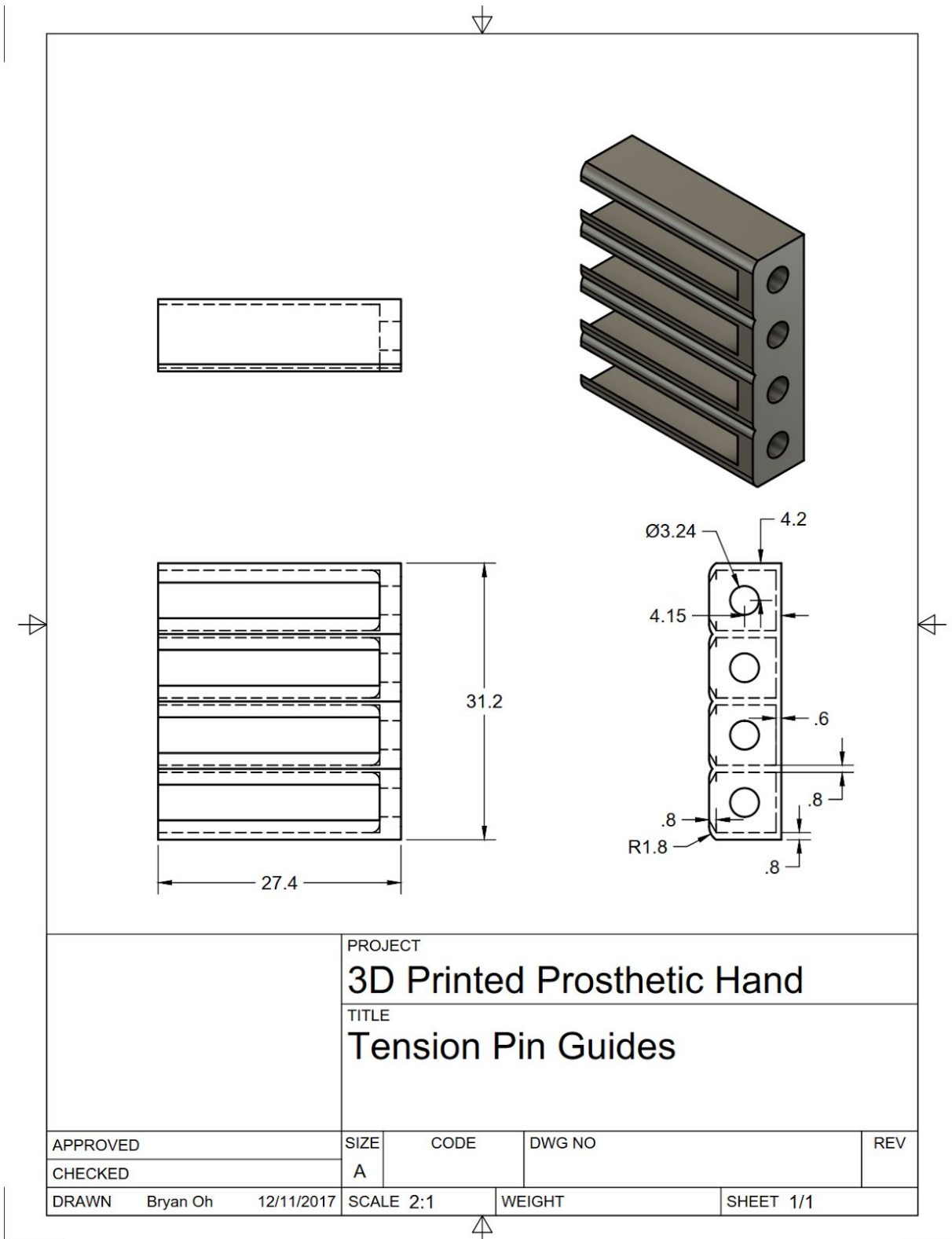

Fig. 44: Tension pin guides CAD model.

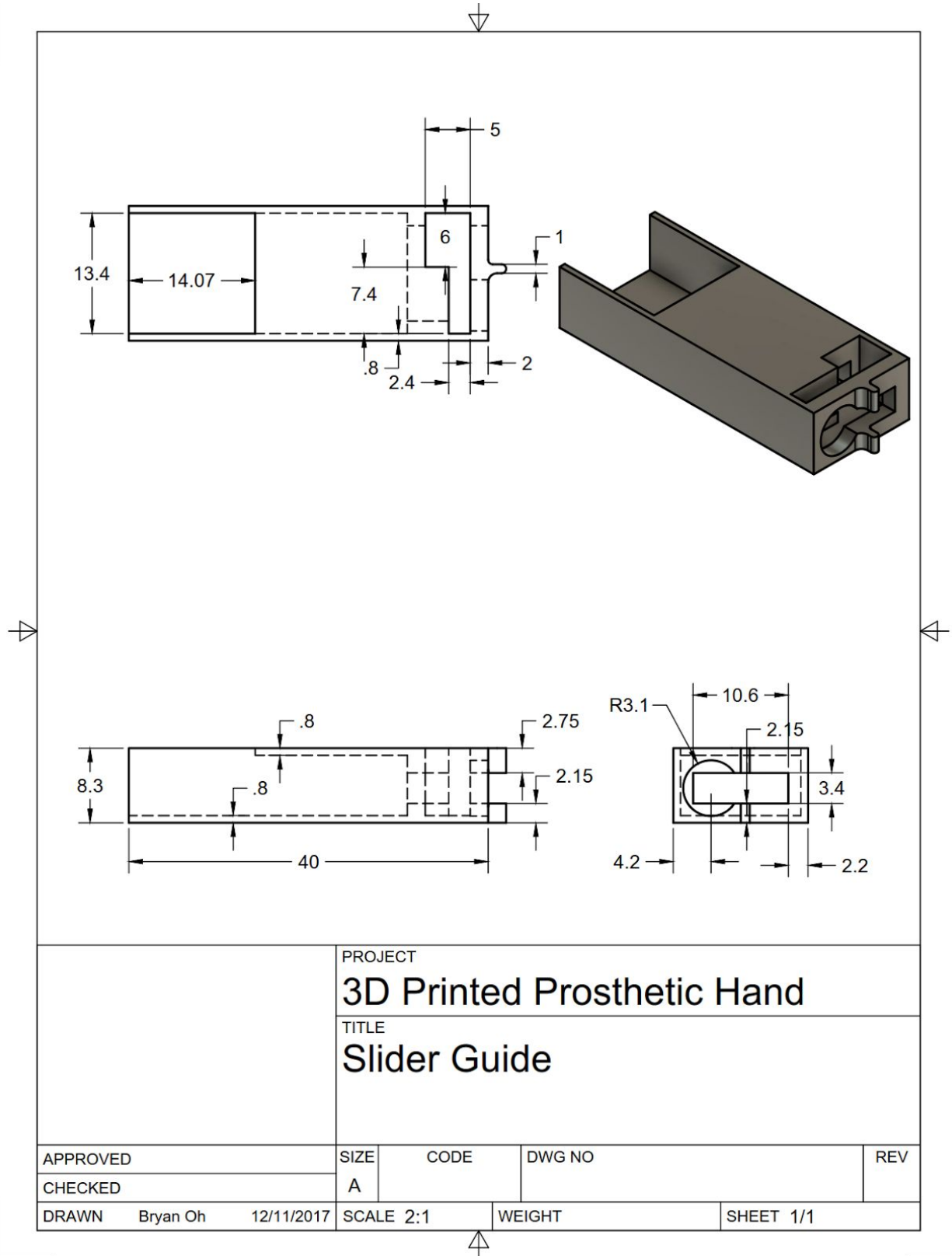

Fig. 45: Slider guide CAD model.

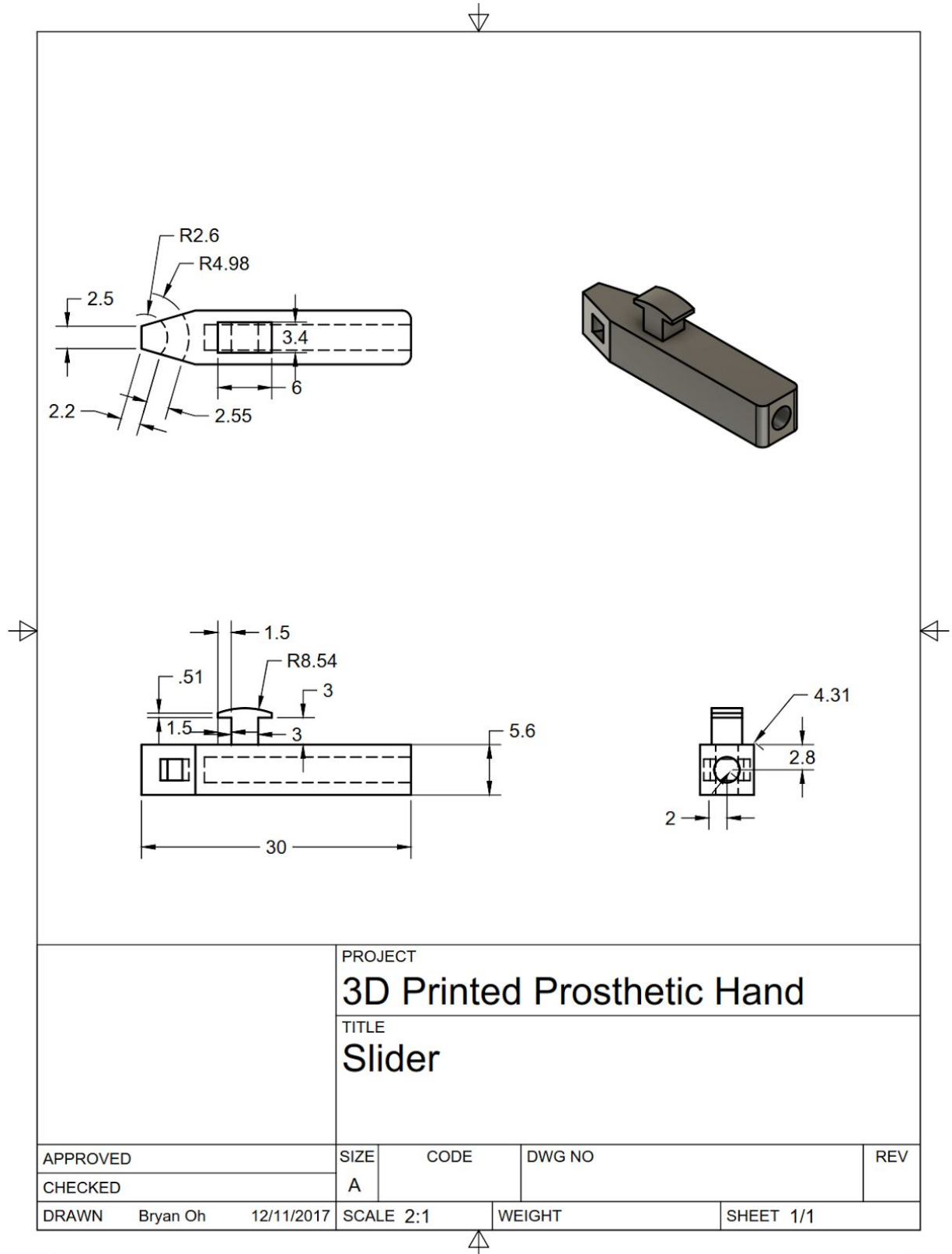

Fig. 46: Slider CAD model.

11 ANNOTATED BIBLIOGRAPHY

Enabling The Future. (n.d.). Retrieved December 08, 2017, from <http://enablingthefuture.org/>

The ENABLE website was instrumental in our research and concept generation stages. The prosthetic designs available here are the leading products in the field, and were consulted extensively during our project. The K1 base model files are available here.

ISO - International Organization for Standardization. (2016, May 26). Retrieved December 08, 2017, from <https://www.iso.org/standard/70205.html>

Standard: Prosthetics - Structural testing of lower-limb prostheses - Requirements and test methods