

Washington University in St. Louis

## Washington University Open Scholarship

---

Mechanical Engineering Design Project Class

Mechanical Engineering & Materials Science

---

Fall 2015

### Backpack I Final Report

James E. Norlin

*Washington University in St Louis*

Catherine G. Roy-Ting

*Washington University in St Louis*

Anna L. Stebbins

*Washington University in St Louis*

Justin Bae

*Washington University in St Louis*

Follow this and additional works at: <https://openscholarship.wustl.edu/mems411>



Part of the [Mechanical Engineering Commons](#)

---

#### Recommended Citation

Norlin, James E.; Roy-Ting, Catherine G.; Stebbins, Anna L.; and Bae, Justin, "Backpack I Final Report" (2015). *Mechanical Engineering Design Project Class*. 28.

<https://openscholarship.wustl.edu/mems411/28>

This Final Report is brought to you for free and open access by the Mechanical Engineering & Materials Science at Washington University Open Scholarship. It has been accepted for inclusion in Mechanical Engineering Design Project Class by an authorized administrator of Washington University Open Scholarship. For more information, please contact [digital@wumail.wustl.edu](mailto:digital@wumail.wustl.edu).

The backpack carrier carries a child between 15 and 35 lbs. safely and securely. The carrier is specifically designed to be useful for a parent traveling with their child by airplane. Key additional features include roll-behind ability, diaper storage, and a stable kickstand mechanism.

---

# Convertible Backpack Carrier Design

---

## Backpack I

---

Justin Bae, James Norlin,  
Catherine Roy-Ting, Anna  
Stebbins

---

## Table of Contents

List of Figures .....	4
List of Tables .....	5
1 Introduction.....	6
1.1 Project problem statement.....	6
1.2 List of team members.....	6
2 Background Information Study.....	6
2.1 A short design brief description that defines and describes the design problem .....	6
2.2 Summary of relevant background information (such as similar existing devices or patents, patent numbers, URL's, et cetera) .....	6
3 Concept Design and Specification .....	8
3.1 User needs, metrics, and quantified needs equations. This will include three main parts: .....	8
3.1.1 Record of the user needs interview .....	8
3.1.2 List of identified metrics .....	13
3.1.3 Table/list of quantified needs equations.....	15
3.2 Four (4) concept drawings .....	15
3.3 A concept selection process. This will have three parts:.....	20
3.3.1 Concept scoring (not screening) .....	20
3.3.2 Preliminary analysis of each concept's physical feasibility.....	22
3.3.3 Final summary .....	23
3.4 Proposed performance measures for the design.....	24
3.5 Design constraints (include at least one example of each of the following).....	24
3.5.1 Functional .....	24
3.5.2 Safety .....	24
3.5.3 Quality.....	24
3.5.4 Manufacturing.....	24
3.5.5 Timing.....	25
3.5.6 Economic .....	25
3.5.7 Ergonomic.....	25
3.5.8 Ecological .....	25
3.5.9 Aesthetic .....	25
3.5.10 Life cycle .....	25

3.5.11	Legal .....	25
4	Embodiment and fabrication plan .....	25
4.1	Embodiment drawing.....	25
4.2	Parts List .....	26
4.3	Draft detail drawings for each manufactured part.....	27
4.4	Description of the design rationale for the choice/size/shape of each part .....	33
4.5	Gantt chart.....	34
5	Engineering analysis .....	34
5.1	Engineering analysis proposal .....	34
5.1.1	A form, signed by your section instructor (insert your form here) .....	34
5.2	Engineering analysis results.....	36
5.2.1	Motivation. Describe why/how the before analysis is the most important thing to study at this time. How does it facilitate carrying the project forward?.....	36
5.2.2	Summary statement of analysis done. Summarize, with some type of readable graphic, the engineering analysis done and the relevant engineering equations.....	36
5.2.3	Methodology. How, exactly, did you get the analysis done? Was any experimentation required? Did you have to build any type of test rig? Was computation used?.....	37
5.2.4	Results. What are the results of your analysis study? Do the results make sense? .....	37
5.2.5	Significance. How will the results influence the final prototype? What dimensions and material choices will be affected? This should be shown with some type of revised embodiment drawing. Ideally, you would show a “before/after” analysis pair of embodiment drawings. ....	38
5.2.6	Summary of code and standards and their influence. Similarly, summarize the relevant codes and standards identified and how they influence revision of the design.....	38
5.3	Risk Assessment .....	39
5.3.1	Risk Identification.....	39
5.3.2	Risk Analysis .....	39
5.3.3	Risk Prioritization .....	39
6	Working prototype .....	40
6.1	A preliminary demonstration of the working prototype (this section may be left blank). ....	40
6.2	A final demonstration of the working prototype (this section may be left blank). ....	40
6.3	At least two digital photographs showing the prototype..... <b>Error! Bookmark not defined.</b>	
6.4	A short videoclip that shows the final prototype performing.....	41
6.5	At least four (4) additional digital photographs and their explanations ..... <b>Error! Bookmark not defined.</b>	
7	Design documentation.....	43

7.1	Final Drawings and Documentation .....	43
7.1.1	A set of engineering drawings that includes all CAD model files and all drawings derived from CAD models. <i>Include units on all CAD drawings.</i> See Appendix C for the CAD models.....	43
7.1.2	Sourcing instructions.....	49
7.2	Final Presentation.....	50
7.2.1	A live presentation in front of the entire class and the instructors (this section may be left blank)	50
7.2.2	A link to a video clip version of 1 .....	50
7.3	Teardown .....	50
8	Discussion .....	50
8.1	Using the final prototype produced to obtain values for metrics, evaluate the quantified needs equations for the design. How well were the needs met? Discuss the result. ....	50
8.2	Discuss any significant parts sourcing issues? Did it make sense to scrounge parts? Did any vendor have an unreasonably long part delivery time? What would be your recommendations for future projects?.....	52
8.3	Discuss the overall experience:.....	52
8.3.1	Was the project more of less difficult than you had expected?.....	52
8.3.2	Does your final project result align with the project description? .....	52
8.3.3	Did your team function well as a group? .....	52
8.3.4	Were your team member's skills complementary?.....	53
8.3.5	Did your team share the workload equally?.....	53
8.3.6	Was any needed skill missing from the group? .....	53
8.3.7	Did you have to consult with your customer during the process, or did you work to the original design brief? .....	53
8.3.8	Did the design brief (as provided by the customer) seem to change during the process?...	53
8.3.9	Has the project enhanced your design skills? .....	53
8.3.10	Would you now feel more comfortable accepting a design project assignment at a job?...	53
8.3.11	Are there projects that you would attempt now that you would not attempt before? .....	53
9	Appendix A - Parts List .....	54
10	Appendix B - Bill of Materials .....	54
11	Appendix C - CAD Models .....	54
12	Annotated Bibliography (limited to 150 words per entry).....	54

List of Figures

Figure 1:..... Pg 7  
Figure 2:..... Pg 7  
Figure 3:..... Pg 15  
Figure 4:.....Pg 16  
Figure 5: ..... Pg 17  
Figure 6: .....Pg 18  
Figure 7: ..... Pg 19  
Figure 8: ..... Pg 20  
Figure 9: ..... Pg 20  
Figure 10: ..... Pg 21  
Figure 11: ..... Pg 21  
Figure 12: ..... Pg 25  
Figure 13: ..... Pg 26  
Figure 14: .....Pg 26  
Figure 15: .....Pg 27  
Figure 16: .....Pg 28  
Figure 17: .....Pg 29  
Figure 18: .....Pg 29  
Figure 19: .....Pg 31  
Figure 20: .....Pg 32  
Figure 21: .....Pg 33  
Figure 22: .....Pg 34  
Figure 23: .....Pg 36  
Figure 24: .....Pg 36  
Figure 25: .....Pg 37  
Figure 26: .....Pg 39  
Figure 27: .....Pg 40  
Figure 28: .....Pg 40  
Figure 29: .....Pg 41  
Figure 30: .....Pg 41  
Figure 31: .....Pg 42  
Figure 32: .....Pg 43  
Figure 33: .....Pg 44  
Figure 34: .....Pg 45  
Figure 35: .....Pg 45  
Figure 36: .....Pg 46  
Figure 37: .....Pg 47  
Figure 38: .....Pg 48  
Figure 39: .....Pg 50

**List of Tables**

[Table 1: Customer needs interview records.....8](#)  
[Table 2: Continued Customer needs interview records.....11](#)  
[Table 3: List of identified metrics.....13](#)

# 1 Introduction

## 1.1 Project problem statement

There are many convertible baby carriers already on the market, but they have few conversions, are difficult to use, and have little storage space. They are also quite complex and often have lots of long straps and unused parts as the result of converted states.

Our aim with this project was to create a small, lightweight baby carrier with many conversions and ample storage space. We wanted to design something that could be worn comfortably for long periods of time and could securely hold both younger and older children in different orientations without hanging straps and fabric between different states.

The difficult part of this project was the assembly. Components of a baby carrier are not easy to find and are often mass-produced specifically for a particular stroller or baby carrier to ensure safety and durability. Obviously, this was not a resource within our grasp, so our carrier ended up being heavier and larger than we would have liked.

## 1.2 List of team members

Justin Bae, James Norlin, Catherine Roy-Ting, Anna Stebbins

# 2 Background Information Study

## 2.1 A short design brief description that defines and describes the design problem

Existing baby carriers are quite clunky; they lack versatility and are rather difficult to use. Our aim with our project was to create something easily portable and versatile enough to be adapted into many different conversion states easily and quickly. We also aimed to create a project that is smaller than the current designs so that it can easily be taken on airplanes, in cars, etc.

## 2.2 Summary of relevant background information (such as similar existing devices or patents, patent numbers, URL's, et cetera)

Small-child Harness: ASTM Patent F2236-14, <http://www.cpsc.gov/en/Regulations-Laws--Standards/Federal-Register-Notices/2014/Safety-Standard-for-Soft-Infant-and-Toddler-Carriers-Final-Rule/> There are many carriers for smaller children currently on the market. Since carriers for smaller children need to provide more support than carriers for older children, most such carriers are made of large swathes of fabric tied around the parent's body with the child inside. They are not very convertible, nor are they straightforward to use. Our small-child harness fits inside of the larger system or can be used alone to make the harness as convertible as possible.



The main danger posed to children is that of falling out of overly large leg holes. To rectify this, the leg holes in our small-child harness are made quite small but covered with a protective padding shaped like a pair of shorts. The protective padding keeps the child's legs from being injured by the smaller leg holes, and the smaller openings keep the child from falling.

Parent Harness: The product currently on the market that most closely resembles ours is covered by US7322498 (<http://www.google.com/patents/US7322498>). The patented harness can be worn on the parent's front or back. Our product adds the amenities of extra storage space and the conversions of the small-child harness, large-child harness, and backpack storage area.

**Figure 1: The image of the patented parent harness already on the market.**

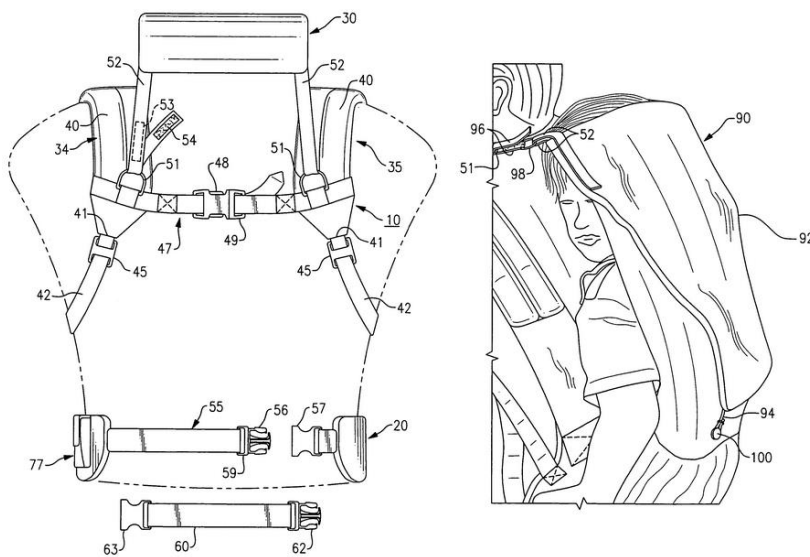

**Figure 2: The image of the patented smaller child carrier already on the market.**

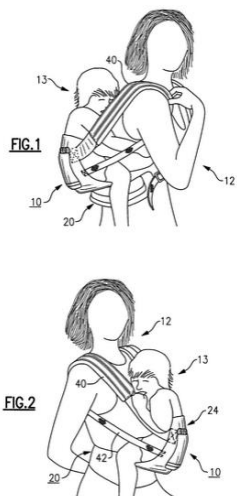

**Storage:** Most current products offer little-to-no storage because there is not room to add it to the space needed to carry a child. Our carrier has two main storage components: a main storage area underneath the child-carrying portion and a smaller storage pocket on the parent waistband to store items such as cash and credit cards.

**Weather Protection:** Most baby products currently on the market are equipped with some sort of weather protection. The main information our research revealed was about the material used to make the protection components. The most useful article we found was in Good Housekeeping Magazine (<http://www.goodhousekeeping.com/institute/a19124/kids-rain-slickers-investigation/>), which detailed the hazards of the waterproof materials used in weather protection.

**Rolling Mechanism:** We used ASTM Patent F833-13b (<https://law.resource.org/pub/us/cfr/ibr/003/astm.f833.2013.html>) as research for the safety components of wheeled strollers. The main safety requirements for strollers involve sturdy breaking, hazardous materials, and harmful components such as swallowable elements. Our wheeling frame stays sturdily in one place thanks to its self-deploying kickstand, has no hazardous materials, and includes no detachable components or small toys.

### 3 Concept Design and Specification

#### 3.1 User needs, metrics, and quantified needs equations. This will include three main parts:

##### 3.1.1 Record of the user needs interview

Ideal Customer:

Parents of children 4 months old - 35lbs who travel on commercial airliners

Dr. Malast, representative of mothers interested in purchasing a convertible backpack-child carrier

Lauren Todd (mother of 29-lb boy)

**Table 1: Customer needs interview records.**

<b>Customer Data: Convertible Backpack</b>	
Customer: Dr. Mary Malast & Dr. Mark Jakiela	
Address: Washington University 2015	Date: 10 September

Question	Customer Statement	Interpreted Need	Importance
What are some challenges with existing products?	Getting the child in and out can be difficult	CB is easy to in-egress	5
	Cumbersome to put the backpack on while getting the child in and out	CB can unload and load child while wearing	5
	Can be a lot of weight on the body	CB is lightweight	5
	Must release in one scoop	CB is easy to release	4
What are the necessary use/capabilities for a backpack?	Shopping, grocery stores, art shows, places that take 1 hour or less of your time	CB is easy to carry	5
	Needs to be advantageous over a stroller	CB is compact	5
		CB is versatile	4
	Free Standing is ideal	CB can free-stand	4
	Easy ingress and egress	CB is easy to in-egress	5
	Extending legs		3
	Protection from the sun		

		<p>CB has extending legs</p> <p>CB has sunshade</p>	4
What are the challenges experienced by parents?	<p>Lack of changing tables</p> <p>Difficulties dismounting backpack without moving the child</p> <p>cost</p>	<p>CB has a foldable surface for diaper changes</p> <p>CB can load and unload without moving the child</p> <p>CB is affordable</p>	<p>3</p> <p>4</p> <p>3</p>
What are the items that you must carry for the child?	<p>Bottles, formula, breast milk</p> <p>Baby wipes</p> <p>Snacks</p> <p>18 diapers</p> <p>Toys</p>	<p>CB is spacious to hold many items</p> <p>CB has compartments</p>	<p>2</p> <p>3</p>

	Binkies Binky clips Rash ointment		
Until how old would you carry the child ?	Not on the back before the age of 1(choking)  Not after the age of 2(dad) and 4(mom)	CB holds children aged 1 to 4	4
Is style important?	Style is not terribly important  Functionality more important  Trendiness is prevalent	CB functionality is dependable	5
What was your experience with air travel with a baby?	Car seats are usually checked  Ergos at 4 months wore it on the plane	CB can fit in plane	4

Table 2: Continued customer needs interview records.

**Customer Data: Convertible Backpack**

Customer: Lauren Todd

Address: Washington University 2015		Date: 10 September	
Question	Customer Statement	Interpreted Need	Importance
What are some challenges with existing products?	You can't release in one swoop	CB releases easily	4
	You cannot strap an ergo to yourself	CB can be strapped alone	4
What are the necessary use/capabilities for a backpack?	You need to get it on in seconds	CB is easy to use	5
	Learning curve for learning how to use it  As easy as possible, As light as possible	CB is lightweight	4
What are the challenges experienced by parents?	The children do not stay still	CB secures children in their place safely	5
What are the items that you must carry for the child?	6-10 diapers  Travel wipes	CB is spacious	3

	Diaper ointment Bottle(1-3) Painkiller Extra clothes for child and parent Books	CB is compartmentalized	3
Until how old would you carry the child ? For how long?	From 3-4 months to 1-2 years  Up to 35 lbs, 12 hours	CB adjusts to different sizes of children	4
Is style important?	Practical products sell	CB is practical	4
What was your experience with air travel with a baby?	Stroller was gate checked  Ergo in the plane	CB fits in the plane(regulation)	4

### List of identified metrics

Table 3: List of identified metrics.

<b>Design Metrics: Convertible Backpack</b>					
Metric Number	Associated Needs	Metric	Units	Min Value	Max Value
1	6, 13	Length	cm	30	70
2	6, 13	Height	cm	10	70

3	6, 13	Width	cm	20	60
4	5,6,13,16	Volume of material	cm <sup>3</sup>	6000	294000
5	17	Number of compartments	integer	1	10
6	12	Price of raw materials	Dollars	10	100
7	5,6,11,13,15,16	Percent of deflation without load	Percentage	0	500%
8	8,9	Extended legs	Binary	0	1
9	10	Sunshade	Binary	0	1
10	5, 14,15	Number of Straps	Integer	1	4
11	8	Free-stand	Binary	0	1
12	7	Number of modes of transportation	Integer	1	5
13	1,2,3,5		Kg	1	10



		Weight			
--	--	--------	--	--	--

### 3.1.2 Table/list of quantified needs equations

Figure 3: Screenshot of quantified needs equations.

Need#	Need	Metric													Happiness	Importance Weight (all entries should add up to 1)	Happiness	
		Length	Height	Width	Volume	Weight	Cost	Time	Material	Complexity	Integration	Shade	Stiffness	Transparency				
1	Easy to ingress														1	0.4	0.1	0.04
2	Can (un)load child while wearing														1	0.5	0.12	0.06
3	lightweight														1	0.4	0.1	0.04
4	Easy to release and carry														1	0.5	0.08	0.04
5	adjustable														1	0.5	0.08	0.04
6	Versatile														1	0.5	0.06	0.03
7	Free stand														0.4	0.395	0.06	0.0237
8	Extending Legs														1	0.5	0.06	0.054
9	Sunshade	0.2	0.2	0.4	0.2										0.878	0.06	0.0527	
10	Foldable surface for diaper	0.1	0.1	0.4	0.4										0.898	0.06	0.0533	
11	Affordable														1	0.5	0.08	0.04
12	Spacious	0.2	0.2	0.4	0.2										0.878	0.06	0.0702	
13	Compartmentalized															0	0.06	0
<b>Units</b>		cm	cm	cm	cm <sup>3</sup>	g	\$	sec	binary	binary	integer	binary	integer	kg	<b>Total Happiness: 0.545</b>			
<b>Best Value</b>		70	70	70	300000	5	1	3	1	1	4	1	5	1				
<b>Worst Value</b>		30	10	30	6000	1	100	30	0	0	1	0	1	5				
<b>Actual Value</b>		15	5	10	750	1000	3	0.3	65									
<b>Normalized Metric Happiness</b>		0.86	0.92	0.81	0.99	0.9	0.5	0.4	0.325									

### 3.2 Four (4) concept drawings

Figure 4: Concept drawing number one.

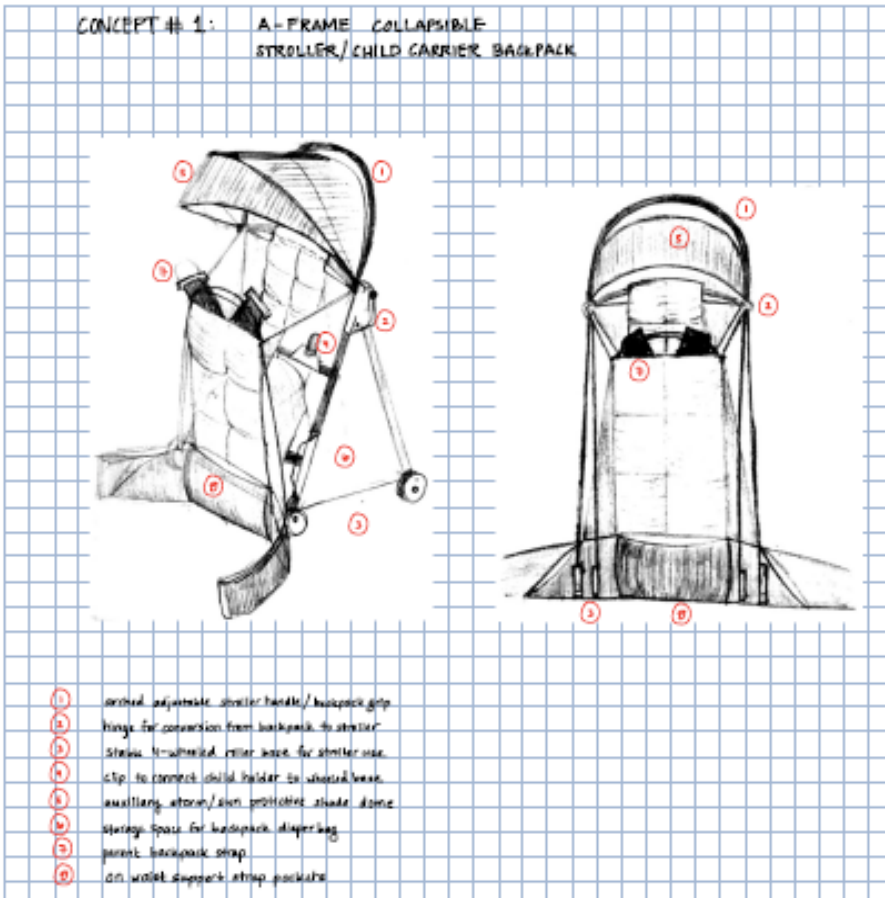

Figure 5: Concept drawing number two.

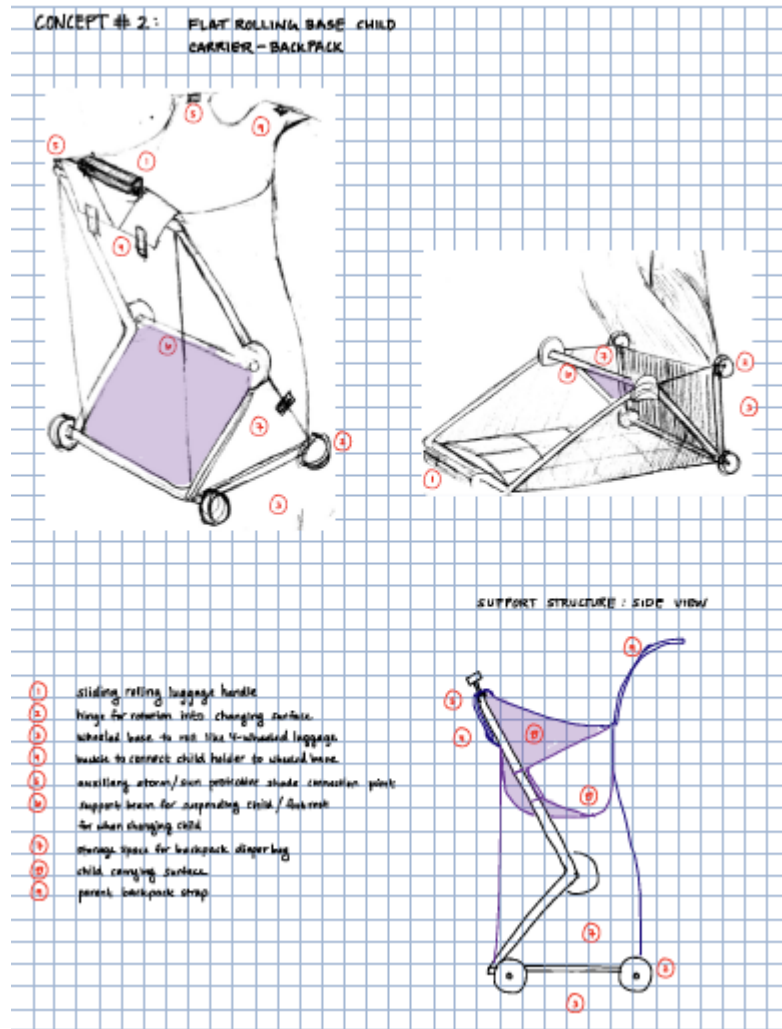

Figure 6: Concept drawing number three.

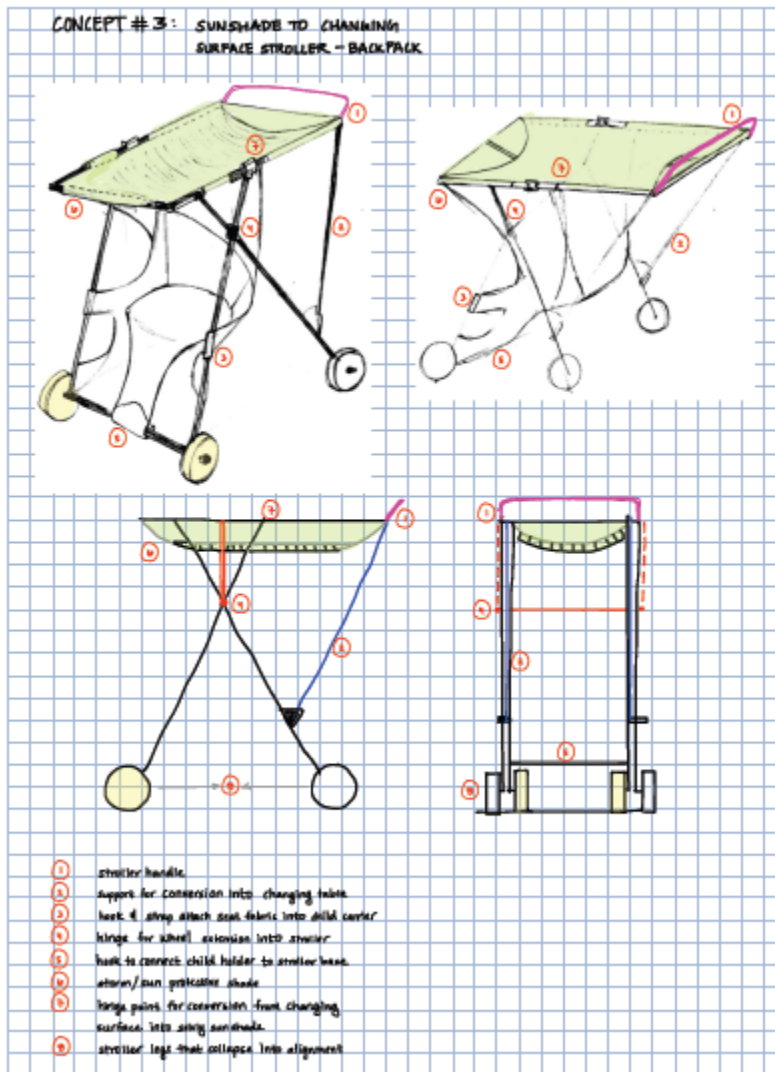
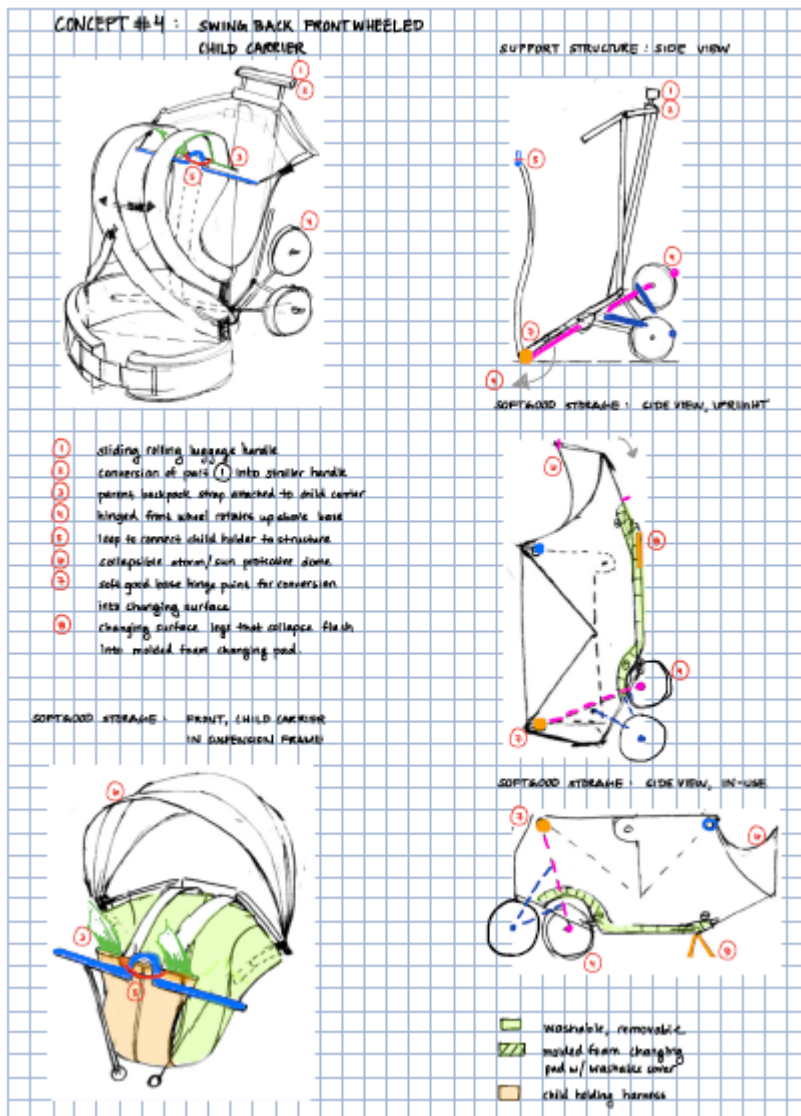

Figure 7: Concept drawing number four.



3.3 A concept selection process. This will have three parts:

3.3.1 Concept scoring (not screening)

Figure 8: Screenshot of concept screening number one.

Convertible Backpack - Concept #1 A-Frame		Metric													Need Happit	Importance Weight (all entries should add	Total Happiness Value
		Length	Height	Width	Volume of	Number of	Price of raw	Time(In/ egress)	Extended	Sunshade	Number of Straps	Free-stand	Modes of	Weight			
Need#	Need	1	2	3	4	5	6	7	8	9	10	11	12	13			
1	Easy to in/egress							1							0.5	0.1	0.05
2	Can (un)load child while wearing						1								0.8	0.12	0.096
3	lightweight							1							0.5	0.1	0.05
4	Easy to release and carry						1								0.8	0.08	0.064
5	adjustable						1								0.8	0.08	0.064
6	Versatile						1								0.8	0.06	0.048
7	Free stand						0.4	0.6							0.32	0.06	0.0192
8	Extending Legs					1									1	0.06	0.06
9	Sunshade	0.2	0.2	0.4	0.2										1	0.06	0.06
10	Foldable surface for diaper	0.1	0.1	0.4	0.4										1	0.06	0.06
11	Affordable						1								0.8	0.08	0.064
12	Spacious	0.2	0.2	0.4	0.2										1	0.08	0.08
13	Compartmentalized														0	0.06	0
Units		cm	cm	cm	cm^3	g	\$	sec	binary	binary	integer	binary	integer	kg	Total Happiness		0.7152
Best Value		70	70	70	300000	5	1	3	1	1	4	1	5	1			
Worst Value		30	10	30	6000	1	100	30	0	0	1	0	1	5			
Actual Value		10	70	30	21000	5	20	15	0	1	2	1	2	2.5			
Normalized Metric Happiness		1	1	1	1	1	0.8	0.5	0					0.4			

Figure 9: Screenshot of concept screening number two.

Convertible Backpack - Concept #2 Flat Rolling Base		Metric											Need Happiness	Importance Weight (all entries should add up to 1)	Total Happiness Value		
		Length	Height	Width	Volume of material	Number of Compartments	Price of raw materials	Time(In/egress)	Extended Legs	Sunshade	Number of Straps	Free-stand				Modes of Transportation	Weight
Need#	Need	1	2	3	4	5	6	7	8	9	10	11	12	13			
1	Easy to in/egress							1							0.5	0.1	0.05
2	Can (un)load child while wearing						1								0.8	0.12	0.096
3	lightweight							1							0.5	0.1	0.05
4	Easy to release and carry						1								0.8	0.08	0.064
5	adjustable						1								0.8	0.08	0.064
6	Versatile						1								0.8	0.06	0.048
7	Free stand						0.4		0.6						0.32	0.06	0.0192
8	Extending Legs					1									1	0.06	0.06
9	Sunshade	0.2	0.2	0.4	0.2										1	0.06	0.06
10	Foldable surface for diaper	0.1	0.1	0.4	0.4										1	0.06	0.06
11	Affordable						1								0.8	0.08	0.064
12	Spacious	0.2	0.2	0.4	0.2										1	0.08	0.08
13	Compartmentalized														0	0.06	0
Units		cm	cm	cm	cm^3	g	\$	sec	binary	binary	integer	binary	integer	kg	Total Happiness		0.7452
Best Value		70	70	70	300000	5	1	3	1	1	4	1	5	1			
Worst Value		30	10	30	6000	1	100	30	0	0	1	0	1	5			
Actual Value		15	70	30	31500	30	40	15	1	1	2	1	2	4			
Normalized Metric Happiness		1	1	1	1	0.9	0.5	0.4	1	1	1	1	1	0.2			

Figure 10: Screenshot of concept screening number three.

Convertible Backpack - Concept #3 Sunshade		Metric											Need Happiness	Importance Weight (all entries should add up to 1)	Total Happiness Value		
		Length	Height	Width	Volume of material	Number of Compartments	Price of raw materials	Time(In/egress)	Extended Legs	Sunshade	Number of Straps	Free-stand				Modes of Transportation	Weight
Need#	Need	1	2	3	4	5	6	7	8	9	10	11	12	13			
1	Easy to in/egress							1							0.5	0.1	0.05
2	Can (un)load child while wearing						1								0.8	0.12	0.096
3	lightweight							1							0.5	0.1	0.05
4	Easy to release and carry						1								0.8	0.08	0.064
5	adjustable						1								0.8	0.08	0.064
6	Versatile						1								0.8	0.06	0.048
7	Free stand						0.4		0.6						0.32	0.06	0.0192
8	Extending Legs					1									1	0.06	0.06
9	Sunshade	0.2	0.2	0.4	0.2										1	0.06	0.06
10	Foldable surface for diaper	0.1	0.1	0.4	0.4										1	0.06	0.06
11	Affordable						1								0.8	0.08	0.064
12	Spacious	0.2	0.2	0.4	0.2										1	0.08	0.08
13	Compartmentalized														0	0.06	0
Units		cm	cm	cm	cm^3	g	\$	sec	binary	binary	integer	binary	integer	kg	Total Happiness		0.7452
Best Value		70	70	70	300000	5	1	3	1	1	4	1	5	1			
Worst Value		30	10	30	6000	1	100	30	0	0	1	0	1	5			
Actual Value		20	70	30	42000	30	40	15	1	1	2	1	2	3			
Normalized Metric Happiness		1	1	1	1	0.5	0.6	0.5	1	1	1	1	1	0.5			

Figure 11: Screenshot of concept scoring number four.

Convertible Backpack - Concept #4 Swingback		Metric											Happiness	Need	Importance Weight (all entries should add up)	Total Happiness Value	
		Length	Height	Width	Volume of material	Number of Compartme	Price of raw materials	Time(In/egress)	Extended leg	Sunshade	Number of Straps	Free-stand					Transportati
Need#	Need	1	2	3	4	5	6	7	8	9	10	11	12	13			
1	Easy to in/egress							1							0.5	0.1	0.05
2	Can (un)load child while wearing						1								0.8	0.12	0.096
3	lightweight							1							0.5	0.1	0.05
4	Easy to release and carry						1								0.8	0.08	0.064
5	adjustable						1								0.8	0.08	0.064
6	Versatile						1								0.8	0.06	0.048
7	Free stand						0.4		0.6						0.32	0.06	0.0192
8	Extending Legs					1									1	0.06	0.06
9	Sunshade	0.2	0.2	0.4	0.2										1	0.06	0.06
10	Foldable surface for diaper	0.1	0.1	0.4	0.4										1	0.06	0.06
11	Affordable						1								0.8	0.08	0.064
12	Spacious	0.2	0.2	0.4	0.2										1	0.08	0.08
13	Compartmentalized														0	0.06	0
Units		cm	cm	cm	cm^3	g	\$	sec	binary	binary	integer	binary	integer	kg	Total Happiness		0.7452
Best Value		70	70	70	300000	5	1	3	1	1	4	1	5	1			
Worst Value		30	10	30	6000	1	100	30	0	0	1	0	1	3			
Actual Value		15	70	30	31500	50	50	15	0	1	3	1	3	5			
Normalized Metric Happiness		1	1	1	1	0.5	0.5	0.5	0	1	1	1	0.6	0.2			

### 3.3.2 Preliminary analysis of each concept's physical feasibility

#### Concept 1:

Concept 1 has relatively few joints and moving parts, and as such would be comparatively easy and cheap to construct. To convert to stroller form, the only necessary change is to alter the position of the legs. Additionally, while not shown in our concept sketch, storage for diapers, toys, and other miscellanea can easily be added. This being said, this design poses certain issues in terms of physical usability, which were not accounted for in our happiness equations. The most concerning of these is that, when in backpack form, the frame which permits stroller functionality will be away from the body, causing a poor distribution of weight and a balance problem. This could be corrected if we were allowed to face the child away from the parent when in the backpack mode, but as is this limits the feasibility of our design. This design would require no special requirements such as very light weight materials.

#### Concept 2:

Concept 2 requires similar mechanical complexity to Concept 1, and is still very feasible to manufacture. Again, no high efficiency motors or the like will be needed. One major concern is that when being used as a backpack, the frame is far away from the body, except for at the base of the back, which leads to less than ideal loadpaths. The only real advantage that this concept has over the first is the addition of a changing table, although its use may not initially be clear to the user. Storage space for diapers is also limited.



### Concept 3:

This concept will require slightly more joints than the previous designs, but at the advantage of having a more stable platform. Like the second concept, it provides a changing table, backpack, and stroller, while because of the alignment of the various frame pieces will cause less imbalance in the backpack mode. This design will not require any special components, and is thoroughly manufacturable.

### Concept 4:

Concept 4's innovation is primarily in the unique strap design. This unique design should allow the user to change the child's position from front to back more easily without removing the backpack. As far as manufacturing, the most difficult part to create will likely be the molded foam pad. The frame is relatively simple, and the design is physically compact when compared to concept 3. It also requires no exotic parts or materials.

### 3.3.3 Final summary

#### Final Summary statement:

Our scores, based on the spreadsheets, are all too close to make accurate determinations from. As such, our determination must be made from our physical estimations. Based on these, we have chosen Concept #4. When compared head to head with #1, #4 offers better weight distribution, easier movement from front to back, and the ability to provide a changing surface. When compared to #2, #4 offers similar weight and expanded size, with the ability to change position from back to front more easily, as well as a more compact design. It will also be much more comfortable due to the molded foam pad. When compared to 3, #4 should be substantially lighter, more compact, and be a much better, more comfortable backpack.

In addition to these comparisons, we believe the 4<sup>th</sup> concept to be more unique and further differentiated from previous designs. The comparative novelty compared to existing products is a major factor in making us consider this design concept. We have never seen a strapping design like this, or one intended to help the user turn the bag between the front and back of the user's body. This novelty adds interest to the project, and we believe that the design meets the requirements for mechanisms which Dr. Jakiela has set.

The washable portion will be significantly better for customer use, and it is worth noting that despite differences in estimated price of components, for all of these designs, we expect to be significantly under budget.

### **3.4 Proposed performance measures for the design**

Performance Goals:

Hold 35 lb child and necessities

Must be able to get in/out in under 15 seconds

Must live through at least 500 washings

Must be movable from front to back in under 15 seconds

Must keep child dry in light rain

Must provide equivalent of SPF 50

### **3.5 Design constraints (include at least one example of each of the following)**

#### **3.5.1 Functional**

The overall Geometry was constrained by the size of the child and by airline carry-on size restrictions.

#### **3.5.2 Safety**

Having a product which is designed to carry children, the elimination of sharp corners was of high importance, as was ensuring that our safe load was more than 3x the expected maximum child weight. Additionally, it is highly important to make sure that the parent has correctly attached all straps, as a missed connection will cause an incorrect loadpath, and potential harm to the child.

#### **3.5.3 Quality**

For product quality, we needed to ensure that failures are both rare and that when failures do occur the risk is minimized (utilizing redundant loadpaths, etc.) To do this, we made sure to thoroughly examine our prototype frame before beginning the fabric work, and built to the code which requires a minimum of 3x factor of safety for the backpack.

#### **3.5.4 Manufacturing**

One major manufacturing constraint was the difficulty of forming hollow tubes into complex curves without appropriate (and expensive) machinery. As such, our frame was more simplified than it otherwise could have been, leading to excess weight.

### 3.5.5 Timing

Our primary timing constraints were the due dates for the various assignments in this class. Of particular note are the initial and working prototype demonstrations.

### 3.5.6 Economic

Material cost was very substantial for us. We estimate that about \$70 of fabric was used in the production of our prototype, although purchasing at an industrial scale would substantially reduce the cost per unit. However, unless the sewing work was off-shored, labor for the sewing work would be a substantial portion of the cost of the design.

### 3.5.7 Ergonomic

Ergonomic constraints are very critical, as our carrier essentially serves to distribute the load of a smaller human onto the torso of a larger human. As such, comfort is very necessary (and is why padding takes up so much of our volume). The adjustability of the straps to fit the parent is also of key importance, as well as the sizing of the leg holes, seat, and so on for the child.

### 3.5.8 Ecological

Our device is very sustainable, using no toxic parts (largely for the safety of the child). Additionally, we use no working fluids, and all of our parts are flame retardant, to meet with safety regulations.

### 3.5.9 Aesthetic

To appeal to small children, we used fabrics with many different bright colors and patterns, such as oranges and blues.

### 3.5.10 Life cycle

The carrier frame is completely recyclable, being made primarily of aluminum. Quietness while rolling is an item we ideally would handle with a nice set of roller bearings, but due to cost have omitted from the prototype.

### 3.5.11 Legal

There are many legal constraints for child carriers of various kinds, regulating what fabrics can be used, what loads must be held (both statically and dynamically) in various locations, and so on. We have complied with and designed to these regulations.

## 4 Embodiment and fabrication plan

### 4.1 Embodiment drawing

Figure 12: Embodiment drawing number one.

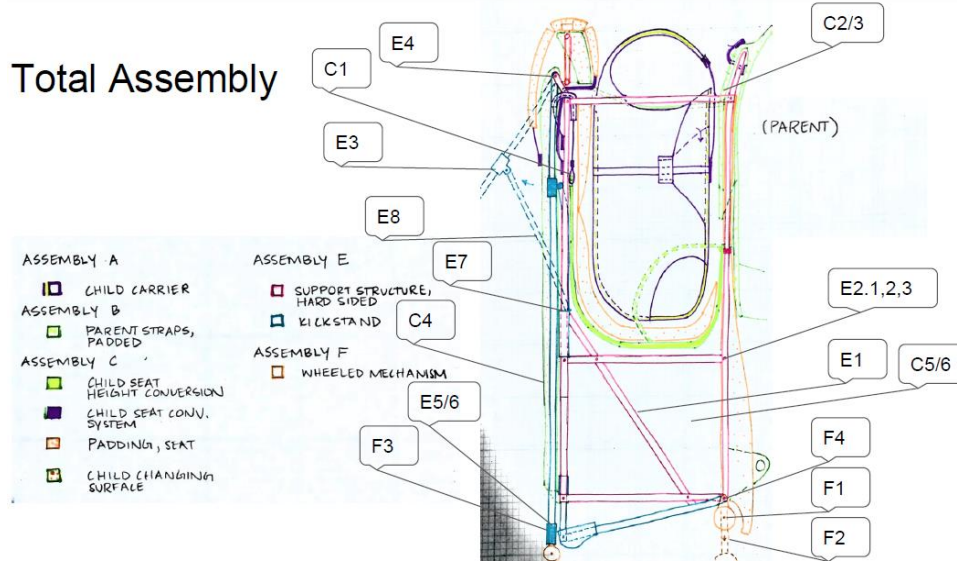
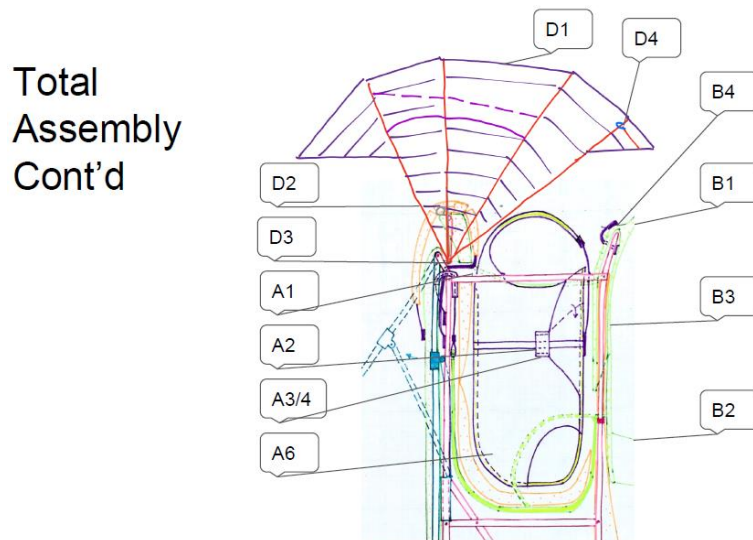

Figure 13: Embodiment drawing number two.



## 4.2 Parts List

Figure 14: Screenshot of parts list.

Component			Component		
ID #	wt.	Description	ID #	wt.	Description
<b>A</b>	<b>7</b>	<b>Small Child Carrier Harness</b>	<b>B</b>	<b>5</b>	<b>Parent Harness</b>
1	1	On-Child harness attachment to Backpack	1	2	On-Parent shoulder straps
2	1	Child attachment into Carrier Harness	2	1	On-Parent waist band
3	1	On-Child attachment to parent harness	3	1	Backpack-parent padding/bag support
4	1	Child harness size conversion elements (clips?)	4	1	On-parent attachment to Backpack
6	3	On-Child Carrier Harness			
			<b>D</b>	<b>6</b>	<b>Auxillary Sun/Rain Protection</b>
<b>C</b>	<b>10</b>	<b>Built-in-Carrier-Backpack</b>	1	1	Removable sun/rain shade - softgood
1	3	Adjustable Height Conversion Mechanism (S1 to S2)	2	2	Removable sun/rain shade - structure
2	1	Child Harness	3	2	Connection to Backpack
3	1	Child Harness padded inserts	4	1	Element to hold non-deployed state (clips)
4	2	Conversion Mechanism of Storage to changing surface			
5	2	Backpack/Storage Struct	<b>E</b>	<b>10</b>	<b>Backpack Support Structure</b>
6	1	Removable diaper bag	1	1	On-Backpack connection to Parent Harness
			2	3	Child weight sustaining beams below child
<b>F</b>	<b>7</b>	<b>Rolling Mechanism (optional)</b>	3	3	Child weight sustaining beams around child
1	1	Wheels	4	1	Backpack Kickstand
2	2	Rods Connecting Wheels to Support Structure	5	2	Backpack Kickstand Integration into structure
3	3	Joints expanding into wheeled mechanism			
4	1	On-Backpack not-in-use axel connection (clip?)			

### 4.3 Draft detail drawings for each manufactured part

Figure 15: Legholder drawing.

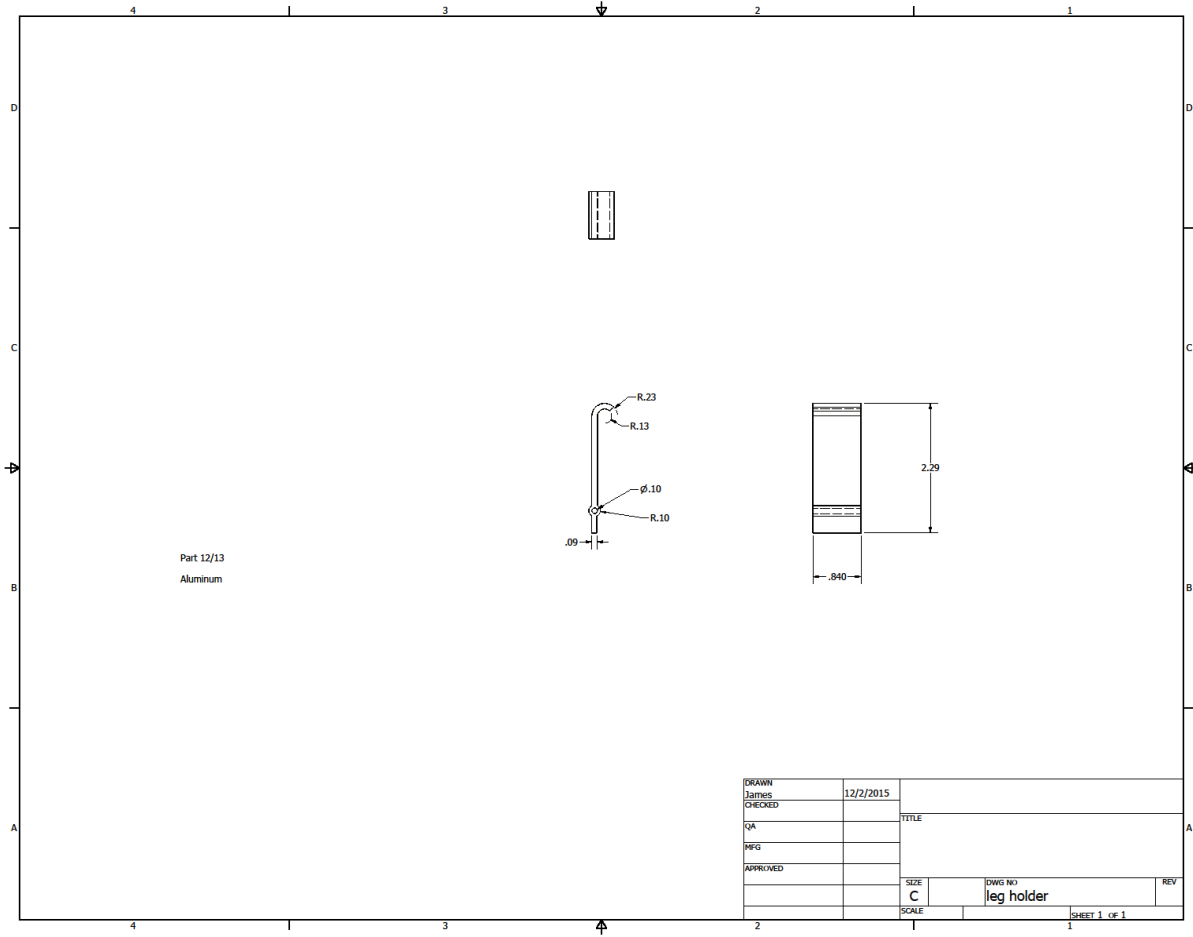

Figure 16: Primary Structure Drawing.

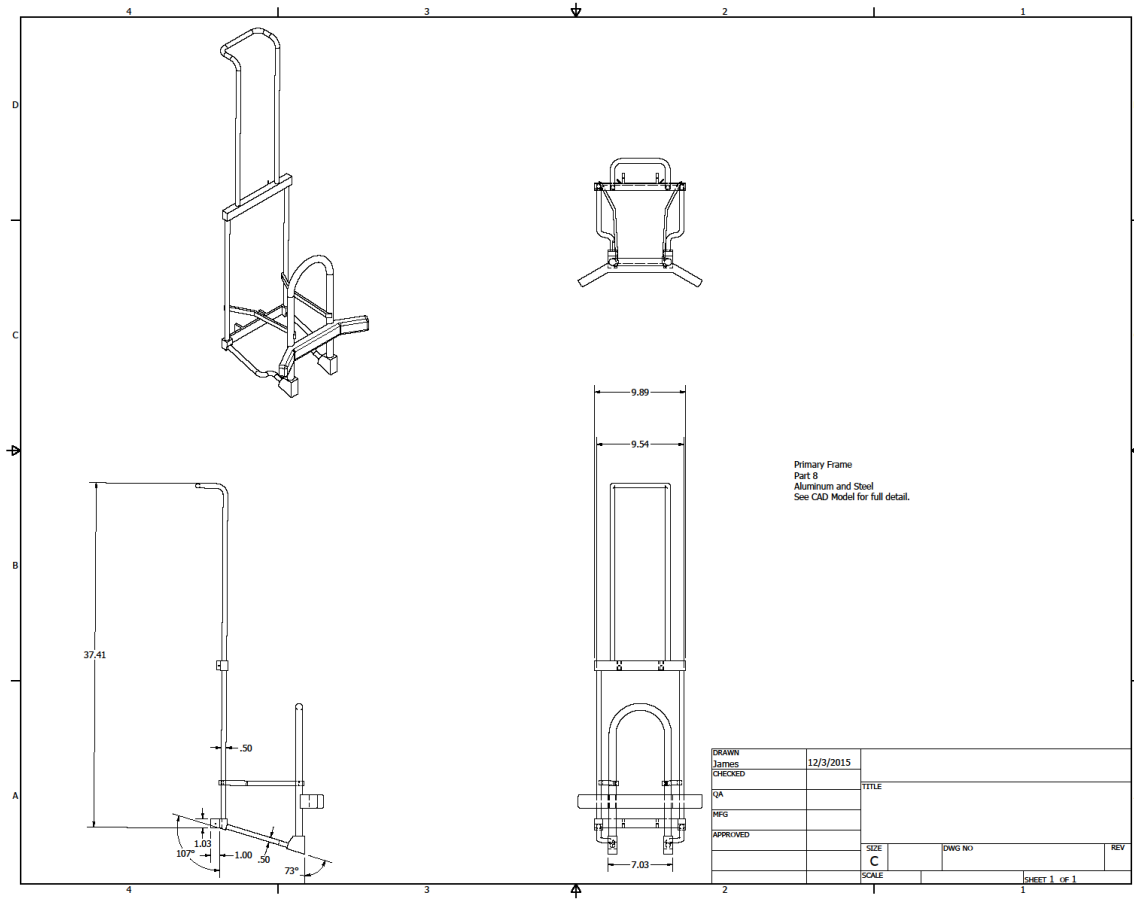

Figure 17: Radial Wheel Lever Drawing.

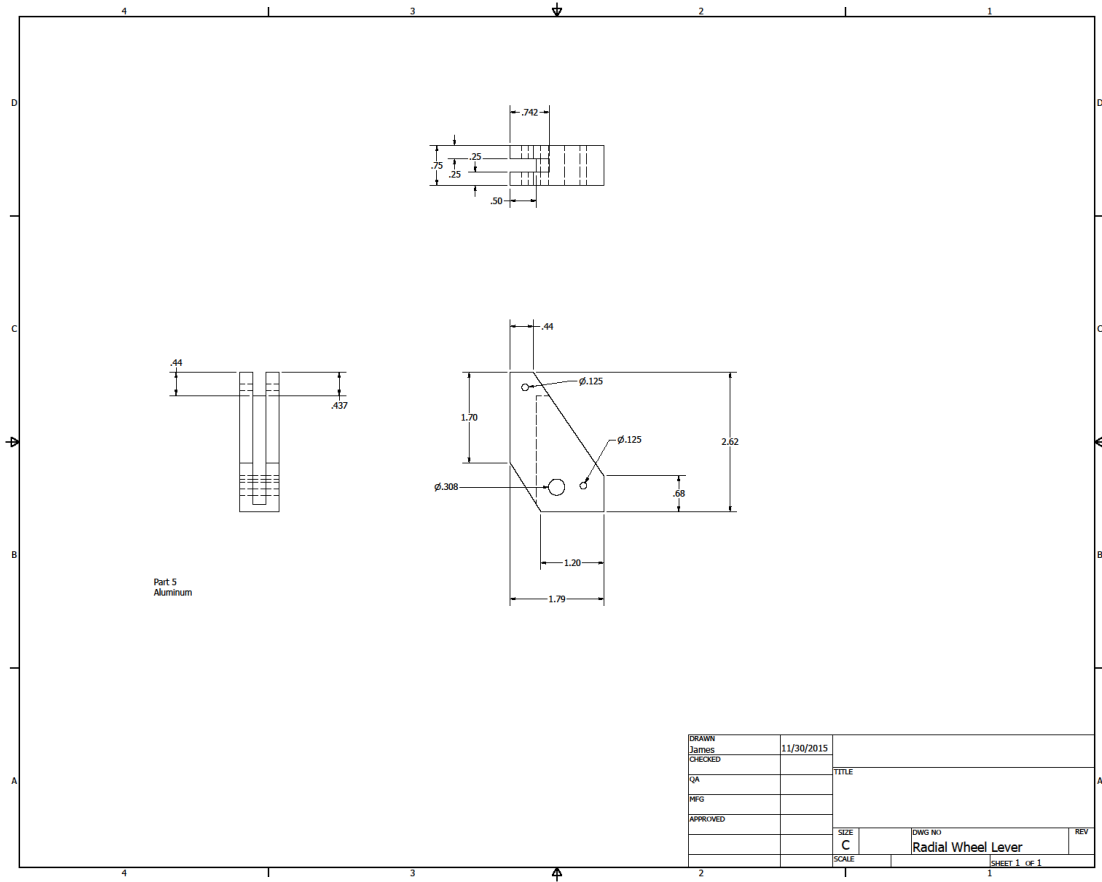

Figure 18: Unistrut Drawing:



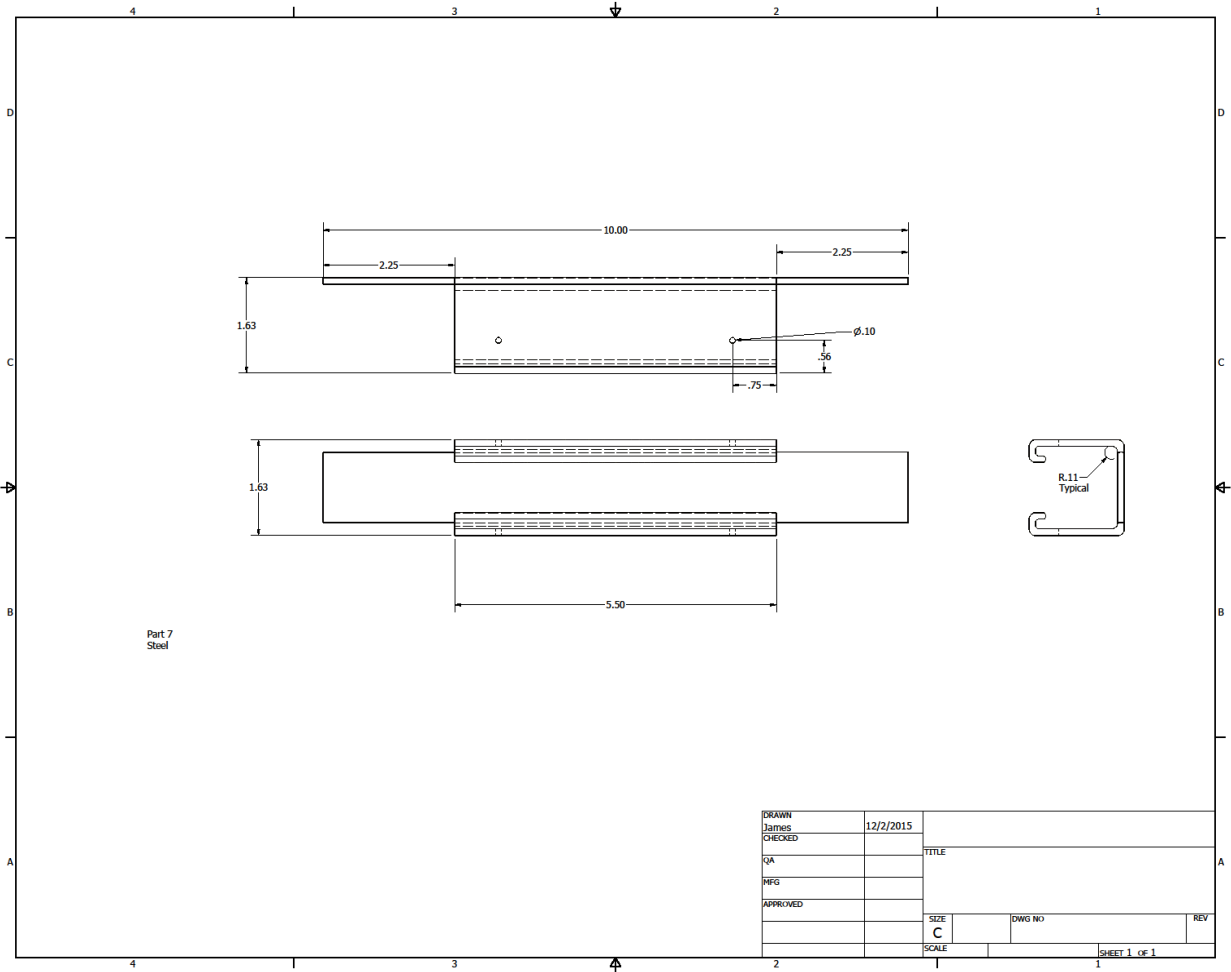

Figure 19: Wheel Rod Drawing.

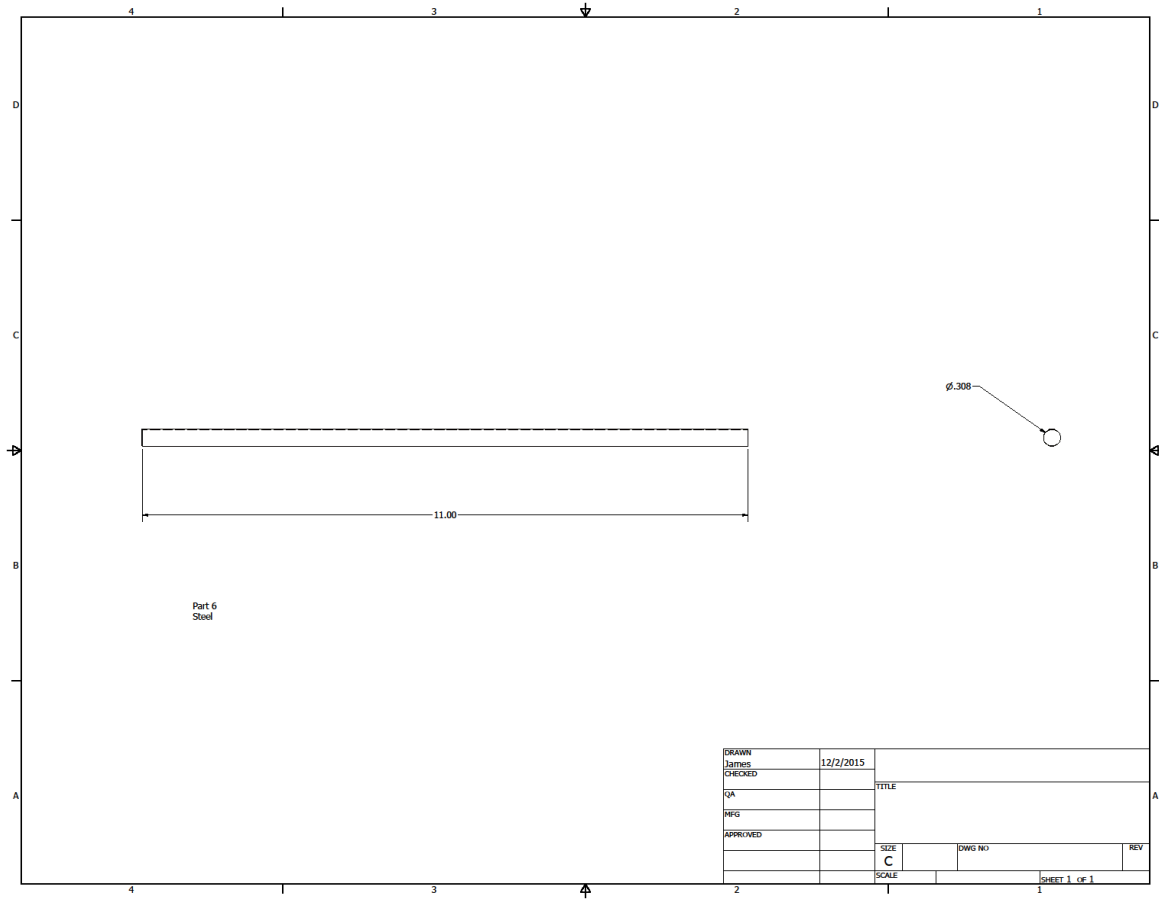
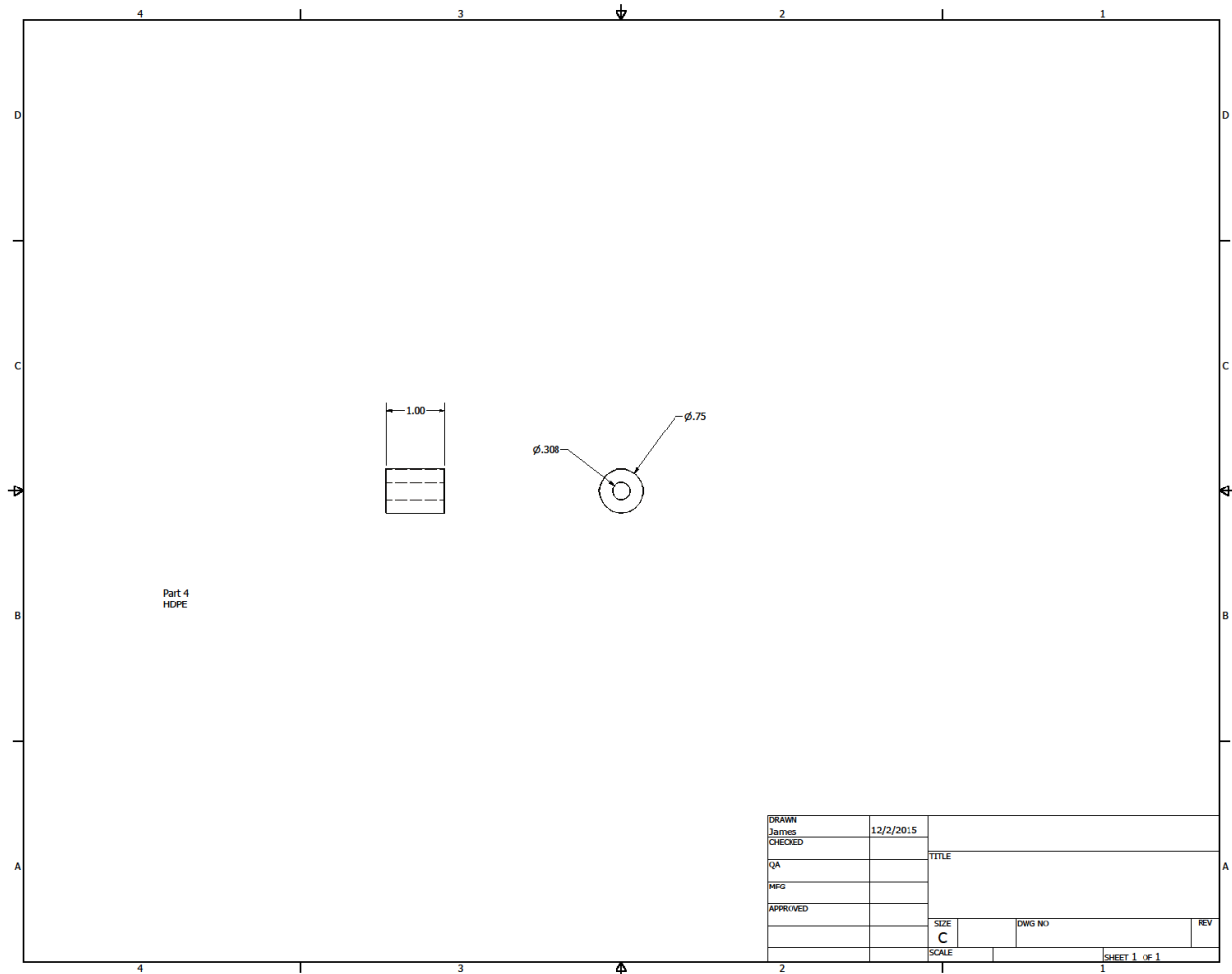

Figure 20: Wheel Spacer Drawing.



#### 4.4 Description of the design rationale for the choice/size/shape of each part

A major goal for our design was to keep the pack within standard carry-on dimensions for most US airline carriers. As such, the pack needed to fit within a 12"x 21"x 9" rectangular prism, which largely determined our frame size. The other major factor determining the size of our mainframe was the size of the child, which ranges from 15 to 35 lbs. At 35 lbs., especially in the width, we did not have much space to work with between the dimensions of the child and the maximum dimensions allowed by carry-on standards.

To roll a carrier or stroller, the minimum comfortable height for a handle tends to be around 40" from the ground, meaning we needed an extending handle from the main frame.

Additionally, it was necessary to widen the frame where it rests against the parent's body, to reduce side-to-side sway.

For our other manufactured parts (the spring pins, leg holders, and Radial Wheel Levers) the primary constraints were caused by the geometric considerations of causing the leg holders to correctly hold the legs when not activated, and to release the legs when activated.

Additionally, the variation in adult torso sizes required a substantial amount of flexibility in the size of the parent harness.

Within those constraints, we sought to minimize weight all around.

### 4.5 Gantt chart

Figure 21: Gantt chart.

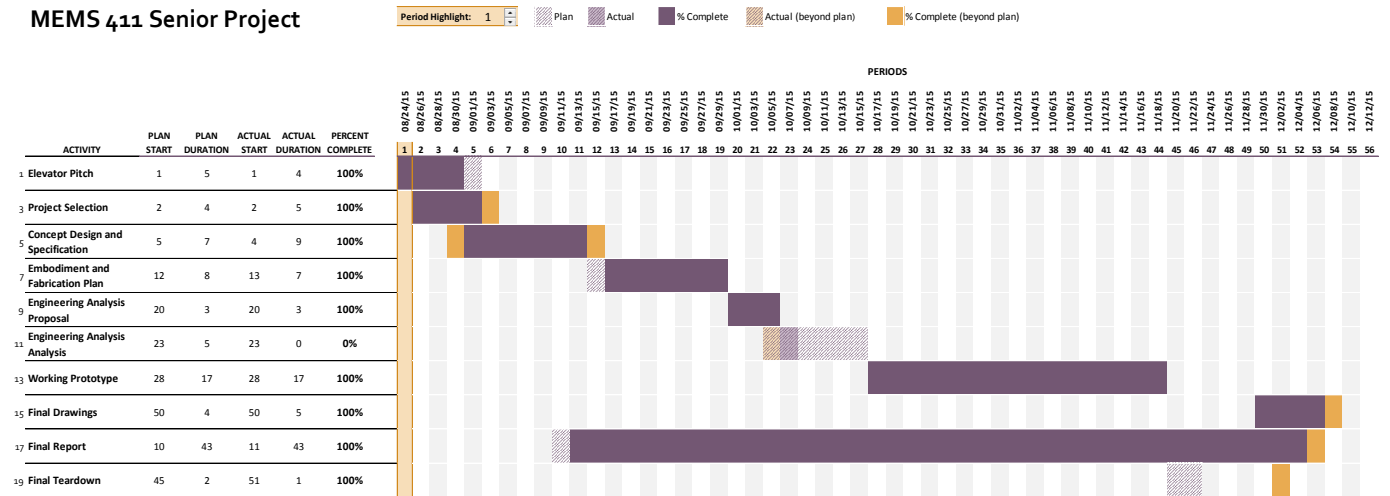

## 5 Engineering analysis

### 5.1 Engineering analysis proposal

#### 5.1.1 A form, signed by your section instructor (insert your form here)

Figure 22: Engineering analysis form.

## ANALYSIS TASKS AGREEMENT

PROJECT: Backpack I NAMES: Justin Bae INSTRUCTOR:

James Norlin

Catherine Roy-Ting

Anna Stebbins

The following engineering analysis tasks will be performed:

Step 1:

Initial planning of baby size – according to weight limits and corresponding body dimensions at each weight.

Output: metric specifications of “S1” and “S2” (maximum and minimum sizes of child)

Step 2:

A. Small Child Carrier Harness

1. On-Child Harness Attachment to backpack – determination of necessary strength
2. Child attachment into carrier harness – determination of comfortable size & shape
3. On-Child attachment to parent harness – determination of necessary strength
4. Child Harness size conversion elements – comfortable placement in relation to child’s body
5. On-Child Carrier Harness – determination of shape, size conversion (as baby grows), and fabric reinforcement to provide necessary strength.

B. Parent Harness

1. On-Parent shoulder straps – determination of necessary strength to carry total weight of bag and baby and range of adult shoulder dimensions
2. On-Parent waist band – determination of minimum dimensions for supporting weight found in part 1.
3. Backpack-parent padding/bag support – analysis of spinal shape and necessary padding for optimal comfort.
4. On-Parent attachment to backpack – determination of necessary strength of hardware, in accordance with weight constraints of part 1.

C. Built-in-Carrier Backpack

1. Adjustable Height Conversion Mechanism (S1 to S2)

## 5.2 Engineering analysis results

### 5.2.1 Motivation. Describe why/how the before analysis is the most important thing to study at this time. How does it facilitate carrying the project forward?

In order to minimize construction cost and time, as well as ensure a safe carriage of children, engineering analysis is imperative. Safety accidents involving children are a very sensitive matter in the industry, and products that aim to be used for children need to go through rigorous engineering and legal testing. Once the engineering analysis confirms that the design is safe for the child to use, only then can the group start building the prototype.

### 5.2.2 Summary statement of analysis done. Summarize, with some type of readable graphic, the engineering analysis done and the relevant engineering equations

The engineering analysis that was done to ensure that the frame could support the weight of the child involved mainly consisted of the calculations of the load that the frames could carry. Two categories existed- the axial load acting on the frames and the joints and the shear loads.

The carrier was to be made out of aluminum 6061, 3/8" outer diameter and 0.343" inner diameter.

The elastic modulus of aluminum 6061 was 68.9 GPa. Therefore, for a 35 lbs child, a factor of safety of 4 was the goal to be achieved.

Actual calculation of axial load

$$\pi(9.53^2mm^2 - 8.71^2mm^2) * 68.9(GPa) = 3.24 * 10^6N$$

this shows that axially it is more than sufficient to support this load.

Similarly, the shear modulus is 86GPa, therefore axial load that can be put on the screws exceed 140 lbs by a large margin (Max load 224294 N)

Similar types of load calculations were done on the components to ensure that the components could withstand the weight.

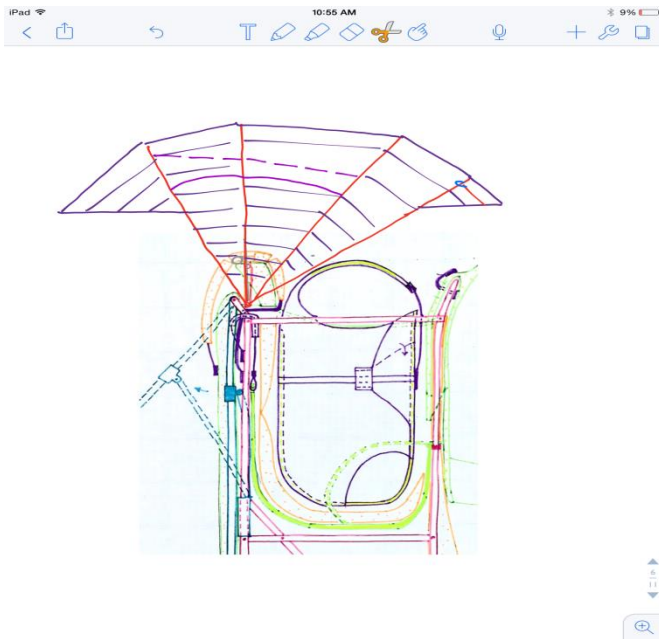
**Figure 23: Side view**

**5.2.3 Methodology. How, exactly, did you get the analysis done? Was any experimentation required? Did you have to build any type of test rig? Was computation used?**

The methods of the engineering analysis mainly involved a theoretical computation with a high factor of safety. The frame design allowed for straightforward understanding of the load under hypothetical situations. In order to experiment the ergonomics of the component, a test rig made out of newspaper and cardboard boxes was made (Checking for potential sharp edges, strap and compartment placements).

**5.2.4 Results. What are the results of your analysis study? Do the results make sense?**

The analysis concluded that structurally the frames were safe to use and could support the baby with a factor of safety of 4. Later, when the frame was constructed out of aluminum, it could support Justin Bae (145lbs). Ergonomic design essential for long term use was also confirmed.

**5.2.5 Significance. How will the results influence the final prototype? What dimensions and material choices will be affected? This should be shown with some type of revised embodiment drawing. Ideally, you would show a “before/after” analysis pair of embodiment drawings.**

The final frame was salvaged off a foldable cart, a foldable aluminum chair, and a foldable child stroller. The results influenced the final frame on the design to have a higher elevation of the chair where the child’s buttocks would be placed. The engineering analysis also revealed that the leg openings were not adequate to support the child; therefore the team widened the leg openings to accommodate the results. Needless frames were eliminated to prevent injuries from sharp or protruding parts.

**Figure 24: Before and after**

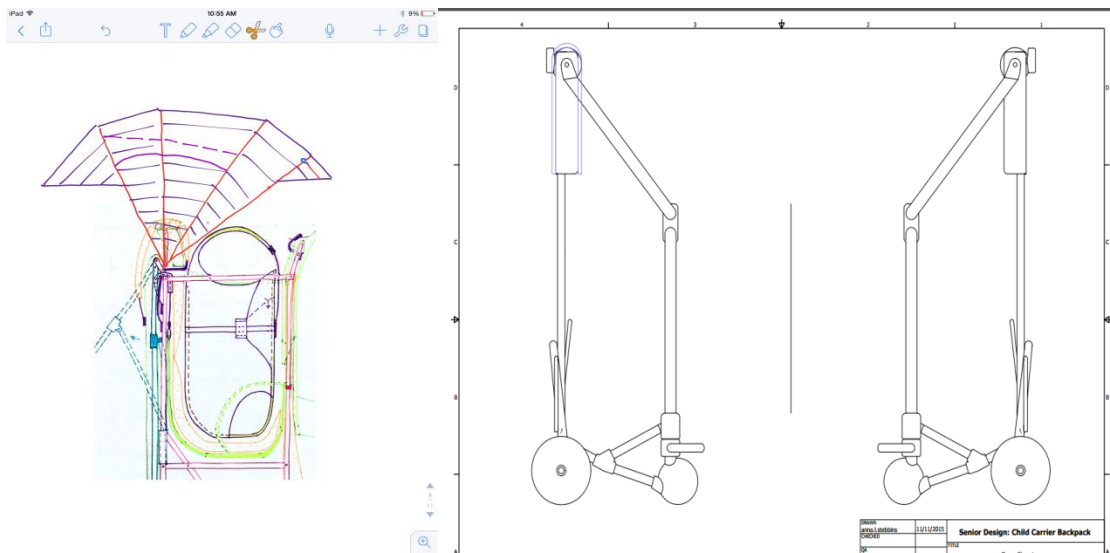

**5.2.6 Summary of code and standards and their influence. Similarly, summarize the relevant codes and standards identified and how they influence revision of the design.**

Due to lack of time and resources, it proved impossible to successfully complete all tests necessary to put our product on the market. The tests are too complex and numerous to summarize here, but using the patents and safety notices listed in our bibliography, we managed to create a product that met the level of safety standard needed for private use.

Of particular concern were the leg openings; safety research showed that most fatalities and injuries involving baby carriers were a result of children falling through large leg openings. This drove our design of small leg openings with a protective elasticized sleeve around both legs. Our other main concern was adjustment pieces. While we wanted to make our carrier convertible; however, we struggled to find adjustment pieces that slipped the required one inch or less while holding weight. We ended up finding metal adjustment pieces with jagged teeth that gripped the straps in order to make sure all components stayed securely in place.



## 5.3 Risk Assessment

### 5.3.1 Risk Identification

One major risk, identified from existing carriers, was the possibility of a child sliding through the leg holes. This was found to be the single most common cause of fatalities from existing child carriers.

Another risk was that the sway of the carrier side-to-side as the parent walked would unduly shake the child, causing harm to the child, as well as uncomfortable unbalancing of the load on the parent's back.

Another risk was that if the carrier were to be set down on just the bottom, it is very unstable, and could fall, causing harm to the child.

### 5.3.2 Risk Analysis

For the possibility of a child sliding through the leg holes, the frequency was rare (in an absolute sense), the effects catastrophic, but easily preventable.

For the side-to-side swaying, the frequency is high as the event occurs every time a parent uses the carrier in the backpack mode. The effects on the child could potentially be very bad, but likely would not be so in most cases. The impingement on the comfortability of the pack is a problematic, but more minor concern. More troubling is the difficulty in minimizing this sway while remaining inside of the design envelope.

The risk of falling carriers is highly dangerous to the child when it happens, but is easily preventable by the use of our kickstand. Using the device correctly, this event will never occur.

### 5.3.3 Risk Prioritization

The side-to-side swaying, having bad effects, but very frequently and in a manner difficult to stop, takes first priority.

For the leg hole issue, we reduced the size of the leg holes such that this is a virtual impossibility.

For the falling issue, it should not occur when the device is used correctly, and the results would generally be less bad than falling through the leg hole, leading to this issue being put to the bottom of the prioritization list.

## 6 Working prototype

6.1 A preliminary demonstration of the working prototype (this section may be left blank).

6.2 A final demonstration of the working prototype (this section may be left blank).

Figure 25: Overall system image.



Figure 26: Overall system image of kickstand deployment.



The overall system includes the small-child harness, the large-child harness, the support system, and the backpack/parent harness. The system is meant to be self-supporting, durable and rigid, protective and comfortable for both parent and child, and sized to allow it to be an airplane carry-on. The child harness is adjustable to allow for either a younger or older child and is securely attached to the support system and parent harness using climbing-strength carabiners. The support system is rigid and allows room for both the child and any items the parent might want to carry. The parent harness is padded for comfortable long wear and rotatable to be worn on the parent's front or back.

### 6.3 A short videoclip that shows the final prototype performing

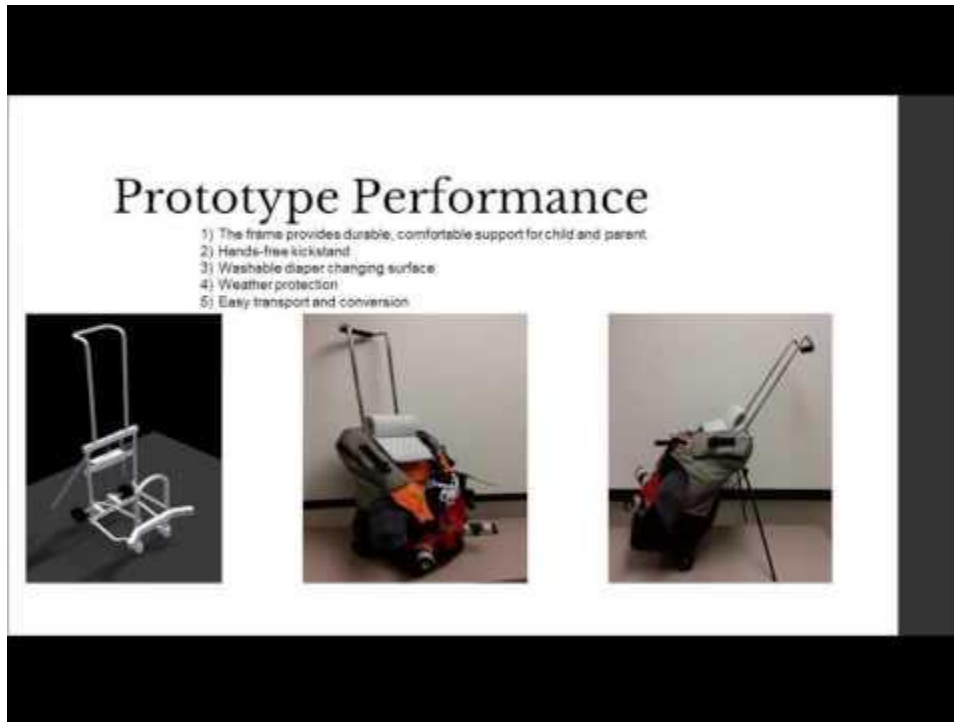

Figure 27: Small child harness image.



The small-child harness is meant for younger babies and fits inside the large-child harness. Our initial research revealed that most injuries and fatalities are a result of smaller children falling out of the leg holes in child harnesses. Thus, we designed a larger area for the baby to sit on and small leg holes with a protective layer to shield the baby's legs from being irritated by the leg holes. The layer looks almost like a small pair of shorts. Sleeves around the neck straps add more protection. The harness is supported by durable clips and a rigid structural insert and is made with padding for protection and comfort. Since the small-child harness sits inside the large-child harness, all amenities of the large-child harness apply to the small-child harness as well.

**Figure 28: Large child harness image.**



The large-child harness is for older children, but the small-child harness can fit inside to hold a younger child. It has secure straps that hold the shoulders, waist, and crotch area of the child to ensure that the child cannot fall out of the harness. It is also padded to provide comfort and protection for the child. Like the small-child harness, we have worked to design leg openings that reduce the risk of a child falling out of the harness. Thus, the harness includes the larger space for the child to sit on, and the smaller leg holes.

**Figure 29: Support frame image.**



The goal of the support system is twofold: rigid structure and ease of transportation. Wheels allow it to be moved, while an automatically deploying kickstand makes the system free-standing. Its size makes it an acceptable airplane carryon. A weather protection attachment is on the top of the support structure to protect the baby from rain, snow, and sun. The area around the

baby's legs is narrower to allow for more comfortable legroom. The back of the structure holds a portable baby-changing mat.

**Figure 30: Parent harness image.**



The parent system is rotatable to allow the child to be carried either on the parent's front or back, thanks to the transition clips on the straps and rotatable waistband. For normal wear, the straps attach at the parent's side. For rotation, the transition clips at the front of the waistband secure the straps and bear the pack's weight during rotation. The waistband also has a pocket for the parent to keep credit cards, cash, and other personal items. The adjustable, padded straps and waistband provide comfort and ease for the parent during long periods of use.

## 7 Design documentation

### 7.1 Final Drawings and Documentation

- 7.1.1 A set of engineering drawings that includes all CAD model files and all drawings derived from CAD models. *Include units on all CAD drawings. See Appendix C for the CAD models.*

**Figure 31: Overall System Drawing.**

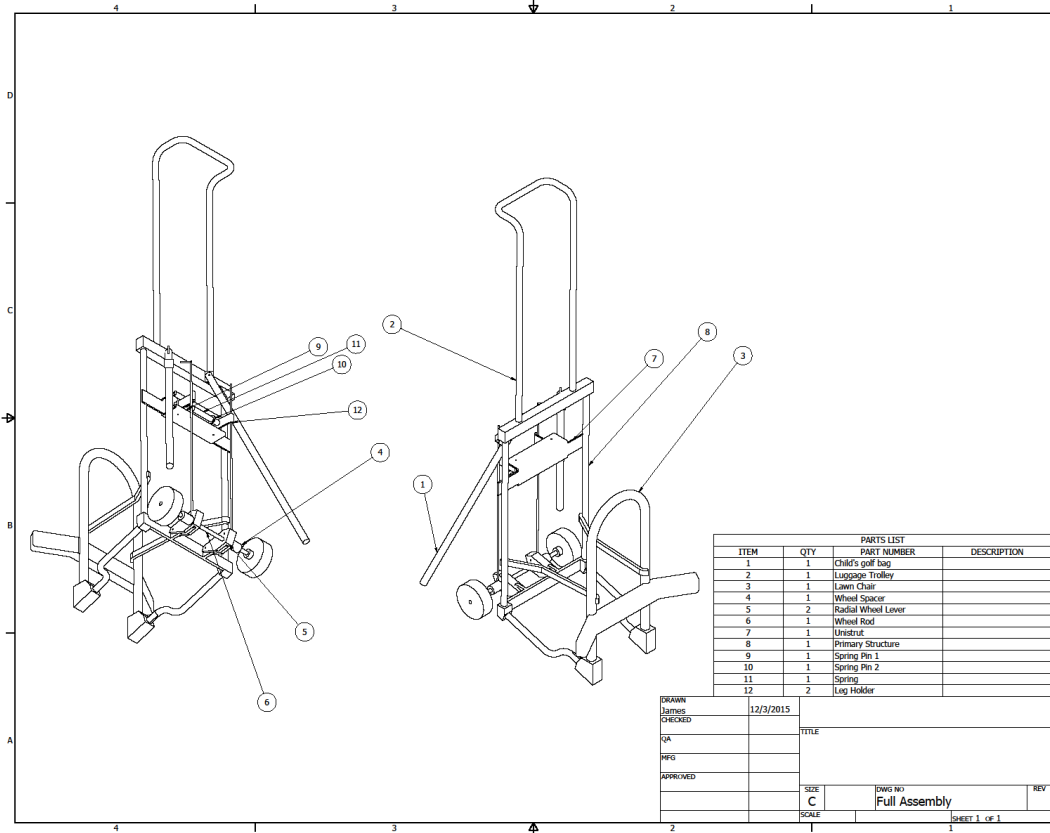

Figure 32: Legholder Drawing.

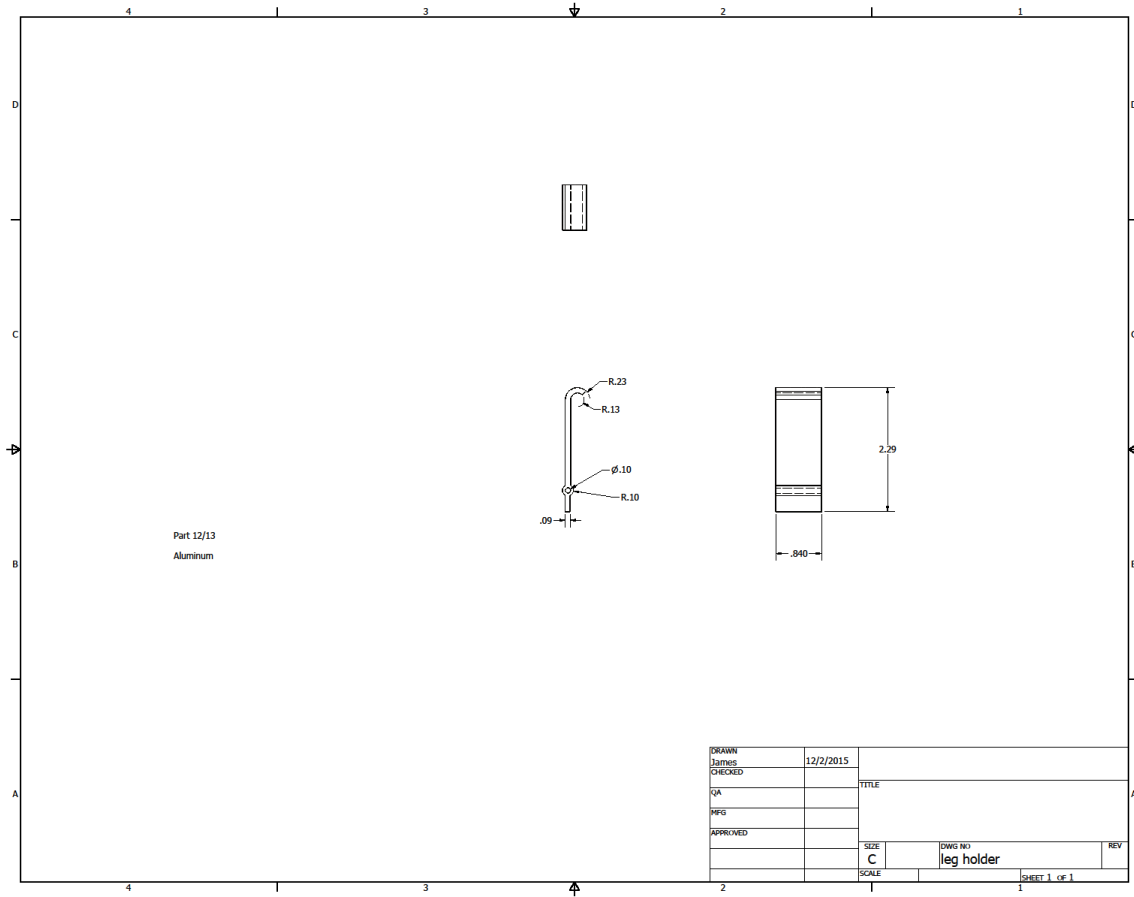

Figure 33: Support Frame Drawing.

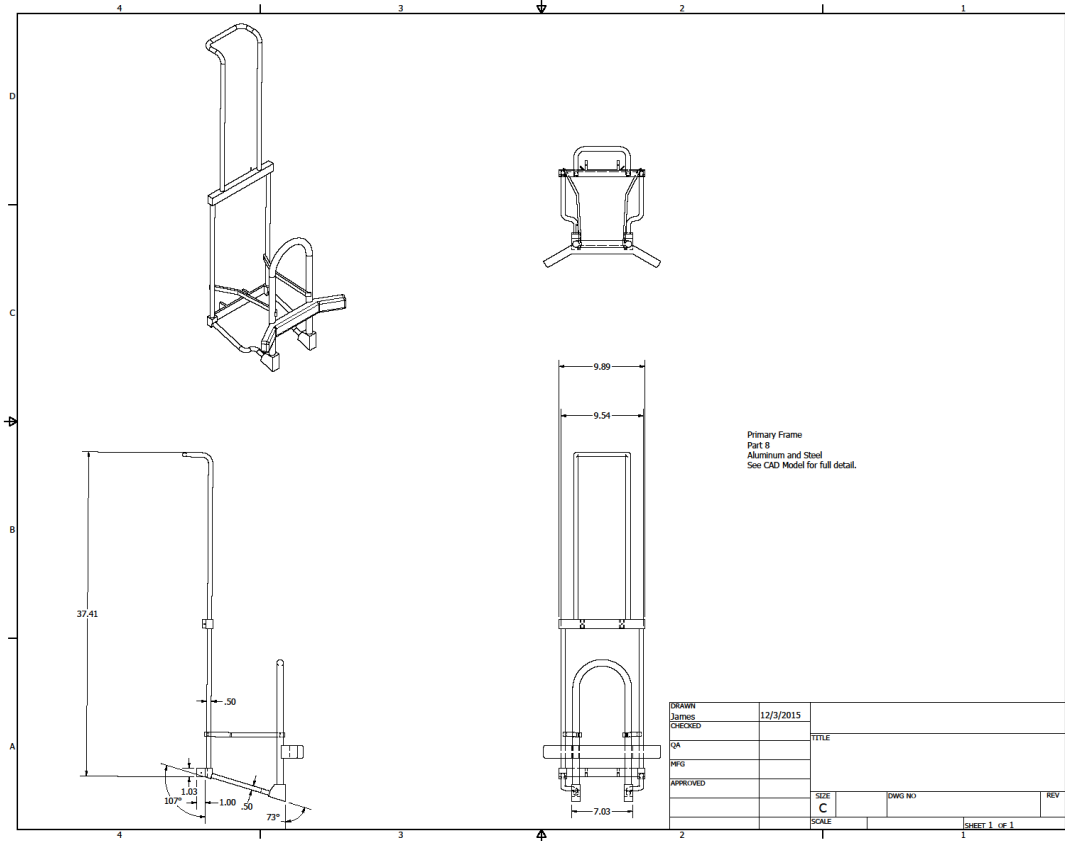

Figure 34: Radial Wheel Lever.



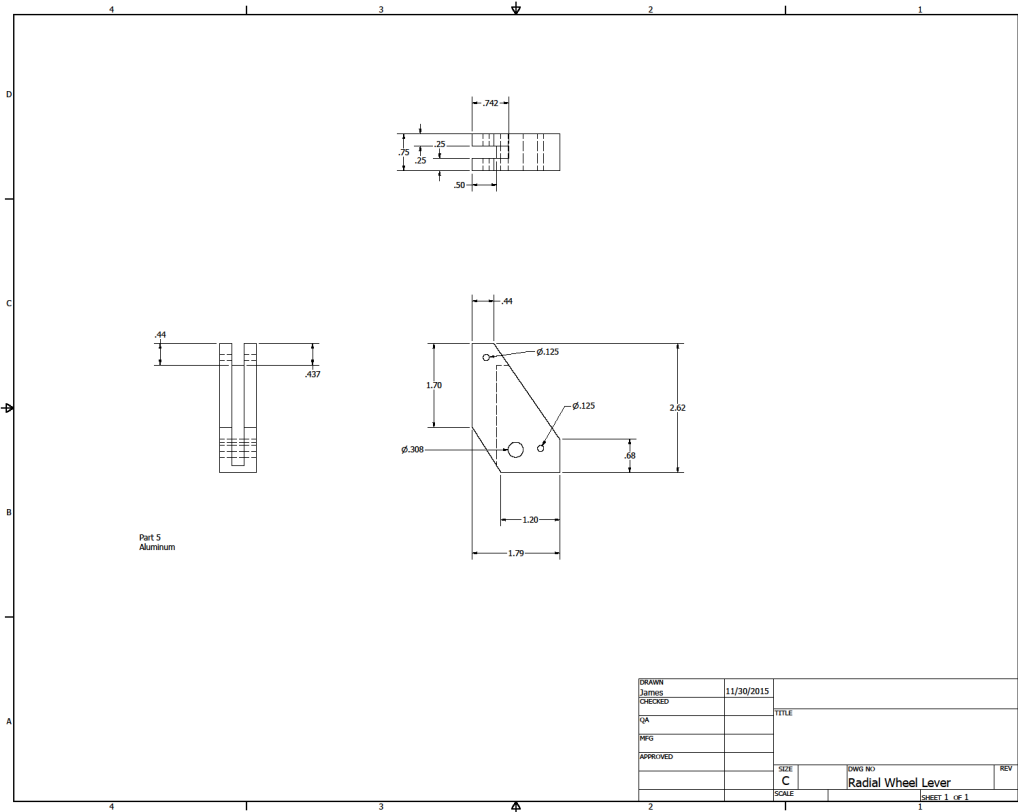

Figure 35: Unistrut Drawing.

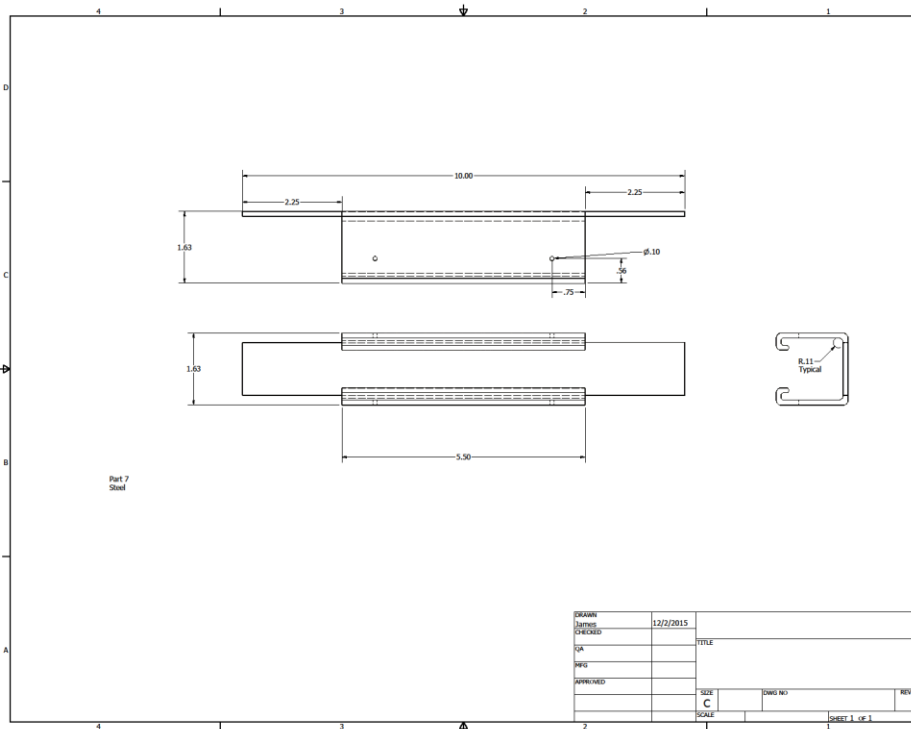

Figure 36: Wheel Rod Drawing.

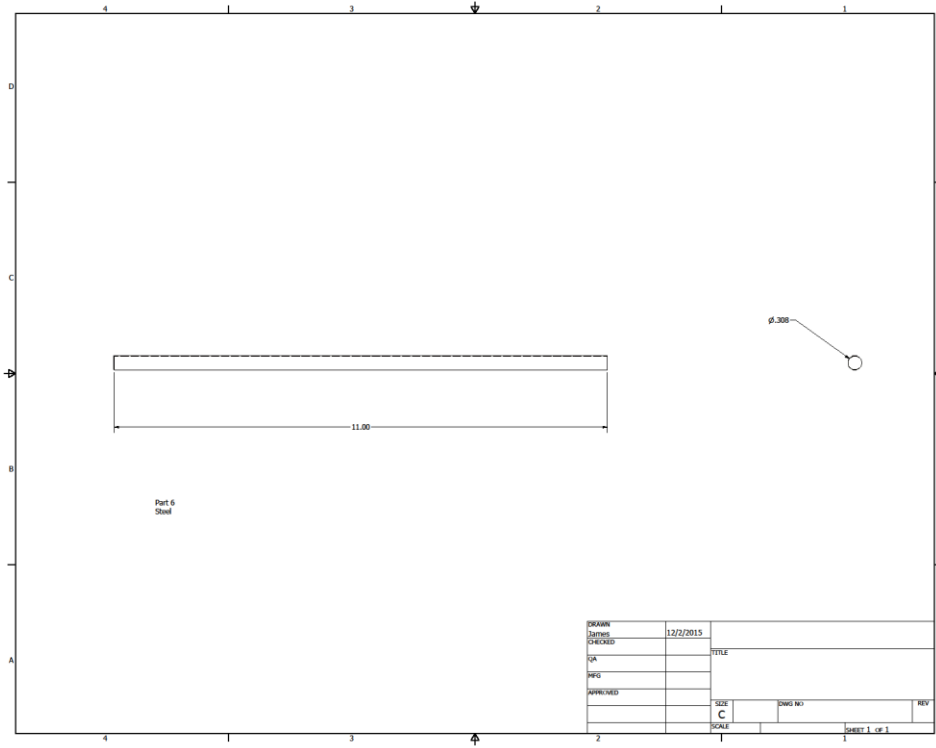
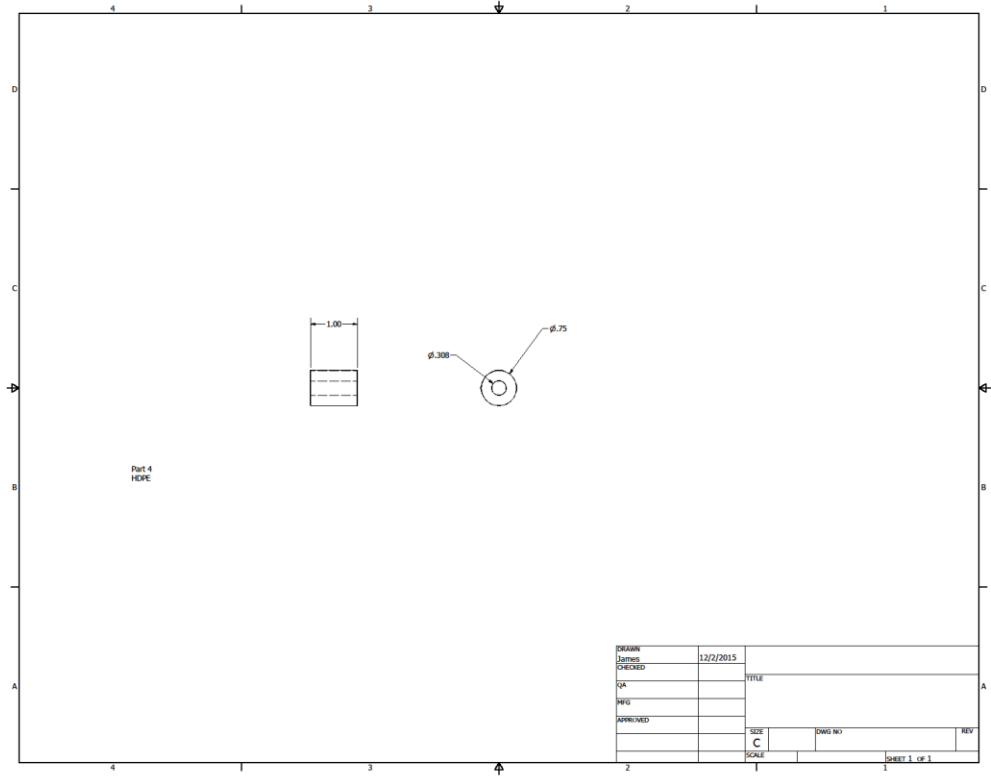

Figure 37: Wheel Spacer Drawing.



### 7.1.2 Sourcing instructions

Figure 38: Screenshot of sourcing instructions.

Part Number	Item	Source	Cost	Description		
1	Child's Golf Bag	<a href="http://www.amazon.com/Paragon-Rising-Star-Junior-Stand/dp/B004XWLDY1">http://www.amazon.com/Paragon-Rising-Star-Junior-Stand/dp/B004XWLDY1</a>	54.95	The kickstand mechanism is to be repurposed for our kickstand		
2	Luggage Trolley	<a href="http://www.amazon.com/dp/B0020ND4QM?psc=1">http://www.amazon.com/dp/B0020ND4QM?psc=1</a>	17.99	This is used to provide much of the backbone of our structure. The wheels are also reused.		
3	Aluminum Lawn Chair	<a href="http://www.amazon.com/Green-and-White-Deluxe">http://www.amazon.com/Green-and-White-Deluxe</a>	60	The chair's tubing is repurposed to provide the aluminum frame		
4	Wheel Spacer	Manufactured	0	This spacer keeps the wheels far enough out to allow necessary rotation of the kickstand mechanism		
5	Radial Wheel Lever	Manufactured	0	This device keeps the spacing of the wheel axle and the kicker connections to the legs in the correct radial and angular relation, while allowing rotation around a common axis.		
6	Wheel Rod	Manufactured	0	This rod replaces the original rod on which the wheels were mounted, allowing for a longer distance between the wheels.		
7	Unistrut	Manufactured	0	This addition to the frame houses the leg release mechanism, which prevents the kickstand from unintentionally deploying.		
8	Primary Structure	Manufactured	0	This structure is manufactured from parts 1, 2, and 3. It provides the basis around which everything else is built.		
9	Spring Pin 1	Manufactured	0	The spring pins lie inside the spring, to prevent the spring from buckling and constraining it to linear motion.		
10	Spring Pin 2	Manufactured	0	The spring pins lie inside the spring, to prevent the spring from buckling and constraining it to linear motion.		
11	Spring	Scrounged	0	Grabbed a 5 in compression spring from the machine shop. A wide range of spring constants are acceptable for our use. The spring puts the leg holders in position to prevent kicker connection movement, without pulling a handle.		
12	Leg Holder 1	Manufactured	0	The leg holder has a loop which holds the kicker connection, preventing the legs from deploying when the bag is being		
13	Leg Holder 2	Manufactured	0	The leg holder has a loop which holds the kicker connection, preventing the legs from deploying when the bag is being rolled.		
14	Fabric Components	Not shown	66.68	The fabric components of the bag provide the seat, cushioning, weather protection, storage, strapping connections to the parent, and more!		

## 7.2 Final Presentation

**7.2.1 A live presentation in front of the entire class and the instructors (this section may be left blank)**

**7.2.2 A link to a video clip version of 1**

[https://youtu.be/eR5cON\\_1QXs](https://youtu.be/eR5cON_1QXs)

## 7.3 Teardown

We cleaned up the machine shop and organized the tools we used, as instructed by Professor Jakiela.

## 8 Discussion

**8.1 Using the final prototype produced to obtain values for metrics, evaluate the quantified needs equations for the design. How well were the needs met? Discuss the result.**

**Figure 39: Screenshot of quantified needs success.**

Convertible Backpack	Metric													Happi	Importance Weight (all entries should add up to)	Happines
	Length	Height	Width	Volume	Mass	Cost	Time	Material	Integration	Number of Sunshade	Number of Sleeves	Number of Straps	Weight			
<b>Need#</b>	<b>1</b>	<b>2</b>	<b>3</b>	<b>4</b>	<b>5</b>	<b>6</b>	<b>7</b>	<b>8</b>	<b>9</b>	<b>10</b>	<b>11</b>	<b>12</b>	<b>13</b>			
1 Easy to ingress							1							0.5	0.1	0.05
2 Can (un)load child while wearing						1								1	0.12	0.12
3 lightweight							1							0.5	0.1	0.05
4 Easy to release and carry						1								1	0.08	0.08
5 adjustable						1								1	0.08	0.08
6 Versatile						1								1	0.06	0.06
7 Free stand						0.4		0.6						0.595	0.06	0.0357
8 Extending Legs					1									0.4	0.06	0.024
9 Sunshade	0.2	0.2	0.4	0.2										0.998	0.06	0.0593
10 Foldable surface for diaper	0.1	0.1	0.4	0.4										0.996	0.06	0.0598
11 Affordable						1								1	0.08	0.08
12 Spacious	0.2	0.2	0.4	0.2										0.998	0.08	0.0798
13 Compartmentalized														0	0.06	0
<b>Units</b>	cm	cm	cm	cm <sup>3</sup>	g	\$	sec	binary	binary	integer	binary	integer	kg	<b>Total Happiness: 0.779</b>		
<b>Best Value</b>	70	70	70	300000	5	1	3	1	1	4	1	5	1			
<b>Worst Value</b>	30	10	30	6000	1	200	30	0	0	1	0	1	5			
<b>Actual Value</b>	20	53.34	20	21336	2	169.48	15	65	1	4	1	4	4			
<b>Normalized Metric Happiness</b>	1	1	1	0.99	0.4	1	0.5	0.325	1	1	1	0.8	0.2			

The happiness matrix gives us a result of 0.779, but some factors (such as cost of raw materials) would improve substantially in mass production, giving us a higher score. In general, the needs were met very well, although the time of child ingress/egress could be lowered significantly, and weight could stand to be reduced.

**8.2 Discuss any significant parts sourcing issues? Did it make sense to scrounge parts? Did any vendor have an unreasonably long part delivery time? What would be your recommendations for future projects?**

We struggled to find non-slip adjustment pieces. The adjustment pieces we had slipped once weight was put into the carrier, and there was very little information on non-slip adjustment pieces. We ended up using metal adjustment pieces with jagged ‘teeth’ that held onto the webbing when tension was put on it.

**8.3 Discuss the overall experience:**

**8.3.1 Was the project more or less difficult than you had expected? The project was much more difficult than we expected. Many baby carriers involve components specifically designed and manufactured for the carrier, and we obviously did not have access to that sort of resource. Our project thus involved a large amount of handmade items, which took time and effort.**

The project was much more difficult than we expected. First, we wanted to make the carrier as convertible as possible. This involved making both the carrier and the frame easily changeable with adding bulky parts or straps. Second, the frame was difficult because it needed to be sturdy but also small, lightweight, and freestanding. The frame was made from a combination of scrounged parts and parts made in the Washington University machine shop, which meant that we had to match our made parts to the recycled parts in a way that that supported the child while fulfilling its other duties. It was especially difficult because we did not have access to aluminum supplies for the frame, so we were forced to use much heavier materials.

**8.3.2 Does your final project result align with the project description?**

Yes, our team functioned well as a group. We had active, productive communication about what was going on with the project, which helped to keep us focused. We also had a clear knowledge of each team member’s skills and clear assignment of duties so that each person could put their skills to the best use.

**8.3.3 Did your team function well as a group?**

Yes, our team functioned well as a group. We had active, productive communication about what was going on with the project, which helped to keep us focused. We also had a clear knowledge of each team members skills and clear assignment of duties so that each person could put their skills to the best use.

### **8.3.4 Were your team member's skills complementary?**

Yes. Anna was the sewer of the group, which was obviously quite helpful for the fabric portion of the bag. James was good at machining parts and using Inventor, which was helpful to create parts of the structure. Justin and Catherine were good at the 'detail' work such as making charts and writing reports.

### **8.3.5 Did your team share the workload equally? Yes, each person had a certain type and amount of work to do depending on their skill set.**

Yes. Each person had a certain type of work to complete depending on their skill set.

### **8.3.6 Was any needed skill missing from the group?**

No skill was particularly missed; each person was able to help the team using the skills he or she had.

### **8.3.7 Did you have to consult with your customer during the process, or did you work to the original design brief? We consulted with customers during the design process and did internet research about existing products in order to improve our design.**

We consulted with customers during the design process and did internet research about existing products in order to improve our design.

### **8.3.8 Did the design brief (as provided by the customer) seem to change during the process? The design brief evolved throughout the project, thanks to what was possible for our group to accomplish and what was really necessary to have on the bag.**

The design brief evolved through the project, thanks to what was possible for our group to accomplish and what components were truly necessary for the bag to have.

### **8.3.9 Has the project enhanced your design skills?**

The design brief evolved through the project, thanks to what was possible for our group to accomplish and what components were truly necessary for the bag to have.

### **8.3.10 Would you now feel more comfortable accepting a design project assignment at a job?**

As stated before, we feel that we now have a more complete knowledge of the design process. This knowledge would make us more comfortable accepting such an assignment. However, we still do not have much experience with the design process when a larger amount of resources to manufacture products is present.

### **8.3.11 Are there projects that you would attempt now that you would not attempt before?**

We enjoyed this project, but we would most likely not attempt it, or others like it, again.

## 9 Appendix A - Parts List

See page 10

## 10 Appendix B - Bill of Materials

Part Number	Item	Source	Cost	Description
1	Child's Golf Bag	<a href="http://www.amazon.com/Paragon-Rising-Star-Junior-Stand/dp/B004XWL DY1">http://www.amazon.com/Paragon-Rising-Star-Junior-Stand/dp/B004XWL DY1</a>	54.95	The kickstand mechanism is to be repurposed for our kickstand
2	Luggage Trolley	<a href="http://www.amazon.com/dp/B002QND4QM?psc=1">http://www.amazon.com/dp/B002QND4QM?psc=1</a>	17.99	This is used to provide much of the backbone of our structure. The wheels are also reused.
3	Aluminum Lawn Chair	<a href="http://www.amazon.com/Green-and-White-Deluxe-">http://www.amazon.com/Green-and-White-Deluxe-</a>	60	The chair's tubing is repurposed to provide the aluminum frame
4	Wheel Spacer	Manufactured	0	This spacer keeps the wheels far enough out to allow necessary rotation of the kickstand mechanism
5	Radial Wheel Lever	Manufactured	0	This device keeps the spacing of the wheel axle and the kicker connections to the legs in the correct radial and angular relation, while allowing rotation around a common axis.
6	Wheel Rod	Manufactured	0	This rod replaces the original rod on which the wheels were mounted, allowing for a longer distance between the wheels.
7	Unistrut	Manufactured	0	This addition to the frame houses the leg release mechanism, which prevents the kickstand from unintentionally deploying.
8	Primary Structure	Manufactured	0	This structure is manufactured from parts 1, 2, and 3. It provides the basis around which everything else is built.
9	Spring Pin 1	Manufactured	0	The spring pins lie inside the spring, to prevent the spring from buckling and constraining it to linear motion.
10	Spring Pin 2	Manufactured	0	The spring pins lie inside the spring, to prevent the spring from buckling and constraining it to linear motion.
11	Spring	Scrounged	0	Grabbed a 5 in compression spring from the machine shop. A wide range of spring constants are acceptable for our use. The spring puts the leg holders in position to prevent kicker connection movement, without pulling a handle.
12	Leg Holder 1	Manufactured	0	The leg holder has a loop which holds the kicker connection, preventing the legs from deploying when the bag is being
13	Leg Holder 2	Manufactured	0	The leg holder has a loop which holds the kicker connection, preventing the legs from deploying when the bag is being rolled.
14	Fabric Components	Not shown	66.68	The fabric components of the bag provide the seat, cushioning, weather protection, storage, strapping connections to the parent, and more!

## 11 Appendix C - CAD Models

Have already been listed twice, see page 43

## 12 Annotated Bibliography (limited to 150 words per entry)

Frost, Karin A. Baby Carrier. The Ergo Baby Carrier, Inc., assignee. Patent US7322498 B2. 29 Jan. 2008. Print.

Institute, The Good Housekeeping. "Kids' Slickers." *Good Housekeeping*. Hearst Communications, Inc., 10 Mar. 2011. Web. 06 Dec. 2015.



N.p., n.d. Web. <<https://law.resource.org/pub/us/cfr/ibr/003/astm.f833.2013.html>>.

"Safety Standard for Soft Infant and Toddler Carriers Final Rule, 16 CFR Parts 1112 and 1226." *US Consumer Product Safety Commission*. US Consumer Product Safety Commission, 28 Mar. 2014. Web. 6 Dec. 2015.