

Washington University in St. Louis

## Washington University Open Scholarship

---

Mechanical Engineering Design Project Class

Mechanical Engineering & Materials Science

---

Fall 12-8-2017

### Torsional Stiffness Measuring Device

Cheyne Shiroma

*Washington University in St. Louis*

Clayton Over

*Washington University in St. Louis*

Nadab Wubshet

*Washington University in St. Louis*

Follow this and additional works at: <https://openscholarship.wustl.edu/mems411>



Part of the [Mechanical Engineering Commons](#)

---

#### Recommended Citation

Shiroma, Cheyne; Over, Clayton; and Wubshet, Nadab, "Torsional Stiffness Measuring Device" (2017).

*Mechanical Engineering Design Project Class*. 81.

<https://openscholarship.wustl.edu/mems411/81>

This Final Report is brought to you for free and open access by the Mechanical Engineering & Materials Science at Washington University Open Scholarship. It has been accepted for inclusion in Mechanical Engineering Design Project Class by an authorized administrator of Washington University Open Scholarship. For more information, please contact [digital@wumail.wustl.edu](mailto:digital@wumail.wustl.edu).



# Washington University in St. Louis

---

## SCHOOL OF ENGINEERING & APPLIED SCIENCE

### *Executive Summary*

Over the course of the semester, our group designed and manufactured a device capable of producing measurements required to calculate the torsional stiffness of a FSAE racecar frame. Torsional stiffness is essentially an object's resistance to being twisted. We worked closely with the Wash U Race Team to identify functional requirements of the product and to compare our results to their expected values. Ultimately, we sought to develop a product that would twist any frame elastically, measure the applied load and displacements, and produce torsional stiffness values within 10% difference of expected values. We wanted the testing procedure to be repeatable, and we wanted the product to be easily assembled and disassembled. Our finished project accomplished all of these performance goals aside from the accuracy of the calculated torsional stiffness value. In hindsight, our goal of 10% difference was probably too ambitious considering the quality of the measurement devices that we had access to. The experimental value of torsional stiffness was 26% different compared to the team's expected values. Our project was most severely limited by time and costs. In an attempt to save on costs, we employed a number of recycled parts from previous projects. In total, we spent \$158.37 on this project out of the allotted \$230.40. We wanted to maintain a comfortable distance away from our cost-limit to troubleshoot towards the end of the project. In retrospect, we could have purchased higher quality equipment to improve the accuracy of our results. To demonstrate our frugality, the total cost of all parts involved in the prototype is \$410.35.

# **MEMS 411: Senior Design Project**

## **Torsion Stiffness Measuring Device**

Cheyne Shiroma

Nadab Wubshet

Clayton Over

**TABLE OF CONTENTS**

List of Figures .....	6
List of Tables .....	7
1 Introduction and Background Information.....	8
1.1 Initial Project Description .....	8
1.2 Existing Products .....	8
1.3 Relevant Patents.....	10
1.4 Codes & Standards.....	10
1.5 Project Scope .....	15
1.6 Project Planning .....	15
1.7 Realistic Constraints .....	15
1.7.1 Functional .....	15
1.7.2 Safety .....	15
1.7.3 Quality.....	16
1.7.4 Manufacturing.....	16
1.7.5 Timing.....	16
1.7.6 Economic .....	16
1.7.7 Ergonomic.....	16
1.7.8 Ecological .....	16
1.7.9 Aesthetic .....	16
1.7.10 Life Cycle.....	17
1.7.11 Legal .....	17
1.8 Revised Project Description.....	17
2 Customer Needs & Product Specifications .....	17
2.1 Customer Interviews .....	17
2.2 Interpreted Customer Needs.....	18
2.3 Target Specifications.....	18
3 Concept Generation .....	20
3.1 Functional Decomposition .....	20
3.2 Morphological Chart .....	20
3.3 Concept #1 – “Name of concept” .....	22
3.4 Concept #2 – “Name of concept” .....	23
3.5 Concept #3 – “Name of concept” .....	24

3.6	Concept #4 – “Name of concept” .....	25
3.7	Concept #5 – “Name of concept” .....	26
3.8	Concept #6 – “Name of concept” .....	27
4	Concept Selection .....	29
4.1	Concept Scoring Matrix .....	29
4.2	Explanation of Winning Concept Scores .....	29
4.3	Explanation of Second-Place Concept Scores .....	29
4.4	Explanation of Third-Place Concept Scores .....	30
4.5	Summary of Evaluation Results.....	30
5	Embodiment & Fabrication plan.....	30
5.1	Isometric Drawing with Bill of Materials .....	31
5.2	Exploded View.....	32
5.3	Additional Views .....	33
6	Engineering Analysis .....	34
6.1	Engineering Analysis Results .....	34
6.1.1	Motivation.....	34
6.1.2	Summary Statement of the Analysis .....	34
6.1.3	Methodology .....	34
6.1.4	Results.....	37
6.1.5	Significance.....	37
6.2	Product Risk Assessment.....	37
6.2.1	Risk Identification.....	38
6.2.2	Risk Heat Map .....	38
6.2.3	Risk Prioritization .....	40
7	Design Documentation.....	41
7.1	Performance Goals.....	41
7.2	Working Prototype Demonstration .....	41
7.2.1	Performance Evaluation .....	41
7.2.2	Working Prototype – Video Link.....	41
7.2.3	Working Prototype – Additional Photos .....	41
7.3	Final Presentation – Video Link .....	45
8	Discussion.....	46
8.1	Design for Manufacturing – Part Redesign for Injection Molding .....	46

8.1.1	Draft Analysis Results .....	46
8.1.2	Explanation of Design Changes .....	47
8.2	Design for Usability – Effect of Impairments on Usability .....	47
8.2.1	Vision.....	47
8.2.2	Hearing.....	47
8.2.3	Physical.....	47
8.2.4	Language.....	47
8.2	Overall Experience.....	47
8.2.1	Does your final project result align with the initial project description? .....	47
8.2.2	Was the project more or less difficult than you had expected?.....	47
8.2.3	In what ways do you wish your final prototype would have performed better? .....	48
8.2.4	Was your group missing any critical information when you evaluated concepts? .....	48
8.2.5	Were there additional engineering analyses that could have helped guide your design? ...	48
8.2.6	How did you identify your most relevant codes and standards and how they influence revision of the design? .....	48
8.2.7	What ethical considerations (from the Engineering Ethics and Design for Environment seminar) are relevant to your device? How could these considerations be addressed? .....	48
8.2.8	On which part(s) of the design process should your group have spent more time? Which parts required less time?.....	48
8.2.9	Was there a task on your Gantt chart that was much harder than expected? Were there any that were much easier?.....	49
8.2.10	Was there a component of your prototype that was significantly easier or harder to make/assemble than you expected? .....	49
8.2.11	If your budget were increased to 10x its original amount, would your approach have changed? If so, in what specific ways?.....	49
8.2.12	If you were able to take the course again with the same project and group, what would you have done differently the second time around?.....	49
8.2.13	Were your team member’s skills complementary? .....	49
8.2.14	Was any needed skill missing from the group? .....	49
8.2.15	Has the project enhanced your design skills? .....	49
8.2.16	Would you now feel more comfortable accepting a design project assignment at a job?...	50
8.2.17	Are there projects you would attempt now that you would not have attempted before? ....	50
9	Appendix A - Parts List .....	51
10	Appendix B - CAD Models .....	51
11	Annotated Bibliography .....	54



**LIST OF FIGURES**

Figure 1 - Torsional measuring device by applying load on a lever arm to create twist. ....	8
Figure 2 – Common design of existing torsional stiffness measuring devices .....	9
Figure 3 – Unique existing design of torsional stiffness measuring device .....	9
Figure 4 – Schematic of a scissor jack .....	10
Figure 5 – Gantt chart illustrating the project schedule .....	15
Figure 6 – Figure shows the functional decomposition of the torsional stiffness measuring device .....	20
Figure 7 – “Simplistic Rig” concept diagram .....	23
Figure 8 – “Grounded Jack & Gauge” concept diagram.....	24
Figure 9 – “Hanging Reference Frame Rig” concept diagram .....	25
Figure 10 – “Frankenstein Rig” concept diagram.....	26
Figure 11 – “Tabletop Screw Jack 5000 Torsional Stiffness Tester” concept diagram.....	27
Figure 12 – “Tabletop Lever Arm 5000 Torsional Stiffness Tester” concept diagram .....	28
Figure 13 - Analytical hierarchical selection process for the criteria of the concept selection matrix .....	29
Figure 14 - Concept selection matrix .....	29
Figure 15 – Isometric drawing with bill of materials.....	31
Figure 16 – Exploded view of torsional stiffness measuring device .....	32
Figure 17 – (a) Right-side view of torsional stiffness measuring device. (b) Top view of device .....	33
Figure 18 - Free Body Diagram of simplified frame and complex solution approach (used fixed joints) .	34
Figure 19 – Free Body Diagram of simplified farm and simplified solution approach (using pin joints)..	35
Figure 20 – von Mises stress results from Solidworks FEA. ....	35
Figure 21 – Displacement results from Solidworks FEA. ....	36
Figure 22 – Resultant force at rear joints from Solidworks FEA. ....	36
Figure 23 – von Mises stress results of the rear support from Solidworks FEA.....	37
Figure 24 - Heat map illustrating the severity and likelihood of different risks .....	40
Figure 25 – Dial indicator with extension rod attached .....	42
Figure 26 – Rear support set in concrete to fix the rear hubs of the chassis .....	43
Figure 27 – Modified bottle jack with pressure gauge to measure the applied force to the chassis .....	44
Figure 28 – Bottle jack attachment for front support.....	44
Figure 29 – Fully assembled torsional stiffness measuring device on the 2015 FSAE chassis .....	45
Figure 30 – Original CAD model of the dial indicator holder designed for PLA printing .....	46
Figure 31 – Redesigned dial indicator holder to account for draft in injection mold printing.....	46
Figure 32 – Part drawing of front support to be manufactured with horizontal saw and vertical mill .....	51
Figure 33 – Part drawing of rear support to be manufactured using vertical mill .....	52
Figure 34 – Part drawing of dial indicator holder to be manufactured using FDM.....	53
Figure 35 – Dial indicator extension rod to be manufacture using horizontal saw, lathe, and drill press ..	54



**LIST OF TABLES**

Table 1 – Customer interviews along with interpreted needs based on customer responses ..... 17

Table 2 – Interpreted customer needs based on the customer’s responses. Needs of importance 5 are of critical importance. Needs of importance 1 are of least importance..... 18

Table 3 – Metrics quantifying customer’s interpreted needs and design team requirements ..... 18

Table 4 – Design challenges and potential solutions ..... 20

Table 5 – Cost accounting workbook of theoretical expenditures ..... 51

# 1 INTRODUCTION AND BACKGROUND INFORMATION

## 1.1 INITIAL PROJECT DESCRIPTION

The problem this product aims to address deals with the torsional deflection of the chassis of a FSAE racecar. This product is necessary when conducting a study of how the chassis reacts when loads are applied to crucial points on the frame. This test simulates how the car will handle/perform in turns and other driving maneuvers. Essentially, the focus of the product was to analyze the lateral load transfer distribution between the front and rear axle. It is assumed that the chassis is rigid in suspension designing. The rigidity of the chassis can be measured on a scale of suspension roll stiffness. This has been found to be directly correlated to the vehicle's handling ability. Most chassis are designed to be 3 to 5 times as stiff as the suspension roll stiffness. The problem is that such a torsional testing rig needs to be built to secure and move specific parts of a chassis. Meaning that most rigs have to rebuild every year to properly fit the specific chassis.

## 1.2 EXISTING PRODUCTS

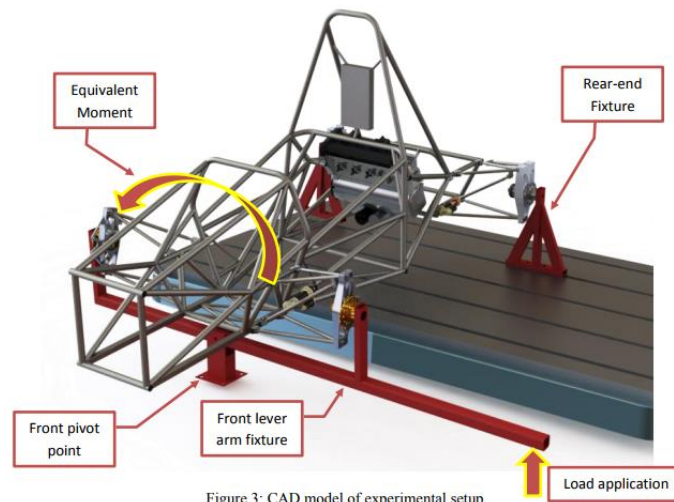

**Figure 1 - Torsional measuring device by applying load on a lever arm to create twist.**

<https://peer.asee.org/development-of-a-test-stand-for-determining-the-torsional-rigidity-of-a-formula-sae-space-frame.pdf>

This product fixes the rear axle to a base and the front axle to a lever. The lever rests on a pivot stand and on one end of the lever a force is applied to create a moment about the length of the chassis. In this product's case, the load is an upward force applied via a car jack.

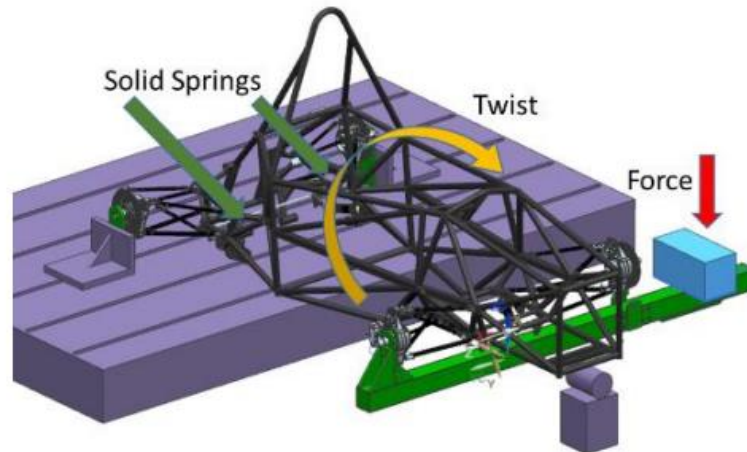

Figure 2 – Common design of existing torsional stiffness measuring devices

<https://deptapps.engin.umich.edu/open/rise/getreport?pid=104&fv=2&file=Chassis+Torsional+Rigidity+Analysis+for+a+Formula+SAE+Racecar.pdf>

This design fixes the rear axle to a base like the previous design. However, this product rests the chassis itself on a roller to allow the chassis to pivot. The lever is not anchored to a base, but is only attached to the front axle. At one end of the lever, a downward force is applied to place the chassis in torsion.

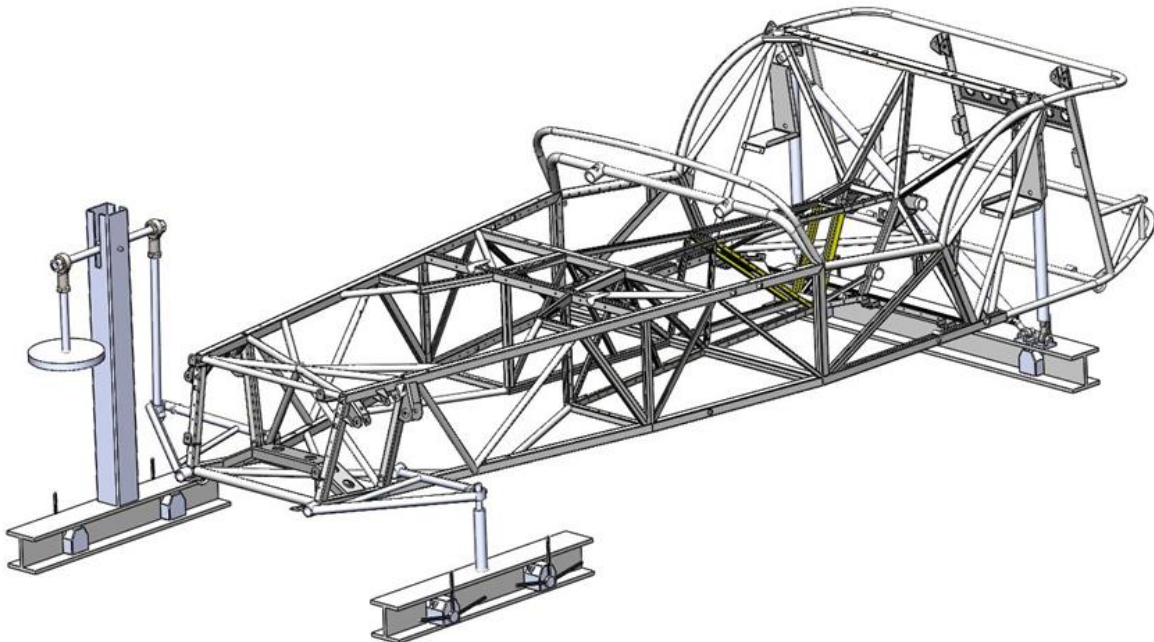

Figure 3 – Unique existing design of torsional stiffness measuring device

[https://justbritish.com/wp-content/uploads/2016/03/Custom\\_Torsion\\_Rig\\_Design.jpg](https://justbritish.com/wp-content/uploads/2016/03/Custom_Torsion_Rig_Design.jpg)

This product anchors three corners of the chassis and uses a seesaw balance to apply an upward force to the front right corner of the chassis. The force can be adjusted by adding/removing external weights to the circular platform on the lever.

### 1.3 RELEVANT PATENTS

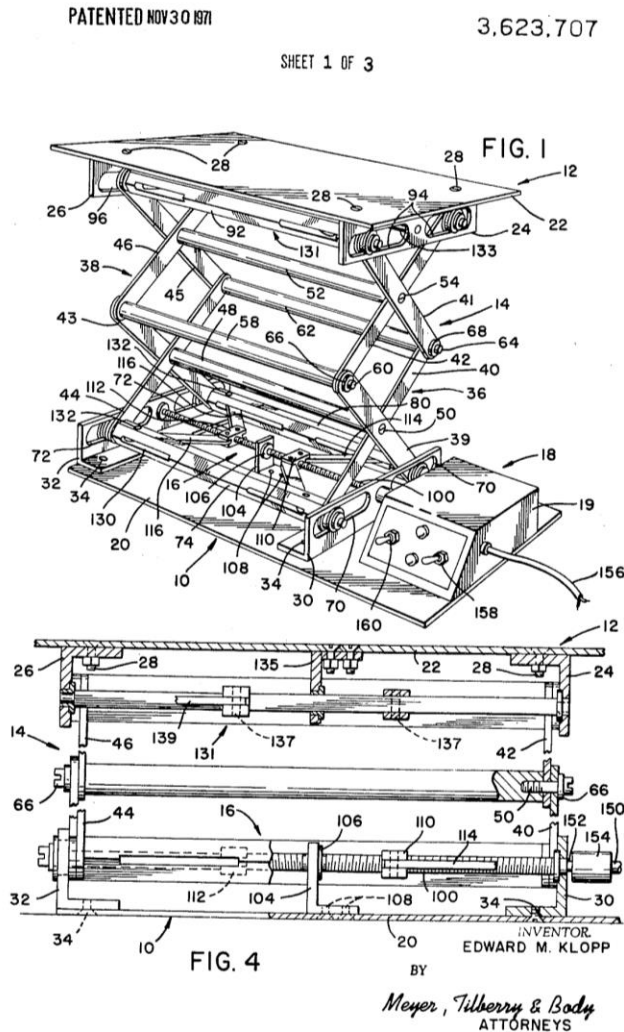



Figure 4 – Schematic of a scissor jack

Patent No. US3623707A

This is a jack, which in the scope of our product would be used to apply a load to the lever of the chassis rig. This jack is operated by an electric rotary motor that drives a threaded rod. On this screw, and nuts that are connected to arms. The arms extend as the screw rotates and extends the jack utilizing a scissor mechanism. The rotation translates to vertical motion of the jack's platform and an upward load.

#### **1.4 CODES & STANDARDS**

Due to the welded joints on our front support, we had to acquire a standard with the purpose of disseminating technical information regarding welding practices. The SAE J1147 standard informed and legitimized our welding processes in the manufacturing stage of our project.

 <p><b>SAE</b> The Engineering Society For Advancing Mobility Land Sea Air and Space® <b>INTERNATIONAL</b> 400 Commonwealth Drive, Warrendale, PA 15096-0001</p>	<p><b>SURFACE VEHICLE INFORMATION REPORT</b></p>	<p><b>SAE</b> J1147</p>	<p>REV. JUN83</p>
		<p>Issued 1976-07 Revised 1983-06</p> <p>Superseding J1147 JUL76</p>	
<p><b>WELDING, BRAZING, AND SOLDERING—MATERIALS AND PRACTICES</b></p>			
<p><b>Foreword</b>—This Document has also changed to comply with the new SAE Technical Standards Board Format.</p> <p><b>1. Scope</b>—The Joint AWS/SAE Committee on Automotive Welding was organized on January 16, 1974, for the primary purpose of facilitating the development and publication of various documents related to the selection, specification, testing, and use of welding materials and practices, particularly for the automotive and related industries. A secondary purpose is the dissemination of technical information.</p> <p><b>1.1</b> SAE participation in this activity is intended to insure that the needs and thinking of the industries mentioned are adequately considered prior to publication of selected Standards, Recommended Practices, and Information Reports. To this end, such documents are subject to the approval of the SAE General Materials Council, as well as the Joint AWS/SAE Committee and the AWS Board of Directions.</p> <p><b>1.2</b> Documents which are approved by the Council are printed as separate sheets or booklets, with both AWS D number and SAE HS J number identifications. They are not published in the SAE Handbook. SAE numbered items approved to date for listing in this Information Report are:</p> <ul style="list-style-type: none"> <li>a. SAE HS J1156 (AWS D8.6-77—Automotive Resistance Spot Welding Electrods. This document recommends a “standard” for spot welding electrodes suitable for use by smaller suppliers to the automotive industry. Typical electrode cap “standards” of the major automobile manufacturers are included for information purposes.</li> <li>b. SAE HS J1188 (AWS D8.7-78)—Specification for Automotive Weld Quality—Resistance Spot Welding.</li> <li>c. SAE HS J1196 (AWS D8.8-79)—Specification for Automotive Frame Weld Quality—Arc Welding.</li> </ul> <p><b>1.3</b> The SAE Metal Joining Subcommittee (disbanded prior to organization of the Joint AWS/SAE Committee on Automotive Welding) developed the following document. This, also, is published only as a handbook supplement.</p> <ul style="list-style-type: none"> <li>a. SAE HS J836—Automotive Metallurgical Joining. This document is an abbreviated summary of metallurgical joining, brazing, and soldering, intended to reflect usage in the automotive industry.</li> </ul>			

SAE Technical Standards Board Rules provide that: "This report is published by SAE to advance the state of technical and engineering sciences. The use of this report is entirely voluntary, and its applicability and suitability for any particular use, including any patent infringement arising therefrom, is the sole responsibility of the user."

SAE reviews each technical report at least every five years at which time it may be reaffirmed, revised, or cancelled. SAE invites your written comments and suggestions.

QUESTIONS REGARDING THIS DOCUMENT: (724) 772-8512 FAX: (724) 776-0243  
TO PLACE A DOCUMENT ORDER: (724) 776-4970 FAX: (724) 776-0790  
SAE WEB ADDRESS <http://www.sae.org>

Copyright 1983 Society of Automotive Engineers, Inc.  
All rights reserved.  
Copyright SAE Inc. 1983  
Provided by IHS Market under license with SAE  
No reproduction or networking permitted without license from IHS

Order Number: 02174673  
Sold to: WASHINGTON UNIVERSITY "DA" [991484] - LAURENTODD@WUSTL.EDU.  
Not for Resale, 2017-10-30 16:09:23 UTC

Printed in U.S.A.

SAE J1147 Revised JUN83

**2. References**

**2.1 Applicable Publications**—The following publications form a part of the specification to the extent specified herein. Unless otherwise indicated the latest revision of SAE publications shall apply.

2.1.1 SAE PUBLICATIONS—Available from SAE, 400 Commonwealth Drive, Warrendale, PA 15096-0001.

SAE HS J836—Automotive Metallurgical Joining.

SAE HS J1156 (AWS D8.6-77)—Automotive Resistance Spot Welding Electrodes.

SAE HS J1188 (AWS D8.7-78)—Specification for Automotive Weld Quality—Resistance Spot Welding.

SAE HS J1198 (AWS D8.7-79)—Specification for Automotive Frame Weld Quality—Arc Welding.

2.1.2 AWS PUBLICATIONS—Available from American Welding Society, 550 LeJeune Road, Miami, FL 33126.

SAE AWS D8.6-77—Automotive Resistance Spot Welding Electrodes.

SAE AWS D8.7-78—Specification for Automotive Weld Quality—Resistance Spot Welding.

SAE AWS D8.7-79—Specification for Automotive Frame Weld Quality—Arc Welding.

**3. Notes**

**3.1 Marginal Indicia**—The change bar (I) located in the left margin is for the convenience of the user in locating areas where technical revisions have been made to the previous issue of the report. An (R) symbol to the left of the document title indicates a complete revision of the report.

PREPARED BY THE AWS/SAE JOINT COMMITTEE ON AUTOMOTIVE WELDING

**SAE J1147 Revised JUN83**

**Rationale**—Not applicable.

**Relationship of SAE Standard to ISO Standard**—Not applicable.

**Application**—The Joint AWS/SAE Committee on Automotive Welding was organized on January 16, 1974, for the primary purpose of facilitating the development and publication of various documents related to the selection, specification, testing, and use of welding materials and practices, particularly for the automotive and related industries. A secondary purpose is the dissemination of technical information.

SAE participation in this activity is intended to insure that the needs and thinking of the industries mentioned are adequately considered prior to publication of selected Standards, Recommended Practices, and Information Reports. To this end, such documents are subject to the approval of the SAE General Materials Council, as well as the Joint AWS/SAE Committee and the AWS Board of Directions.

Documents which are approved by the Council are printed as separate sheets or booklets, with both AWS D number and SAE HS J number identifications.

**Reference Section**

SAE HS J1156 (AWS D8.6-77)—Automotive Resistance Spot Welding Electrodes

SAE HS J1188 (AWS D8.7-78)—Specification for Automotive Weld Quality—Resistance Spot Welding

SAE HS J1196 (AWS D8.8-79)—Specification for Automotive Frame Weld Quality—Arc Welding

SAE HS J836—Automotive Metallurgical Joining

**Developed by the AWS/SAE Joint Committee on Automotive Welding**



### 1.5 PROJECT SCOPE

Compare the percent difference between experimental data and simulation results. The device must be able to test multiple frames of varying geometry. The test results our device output will influence design decisions such as frame size and structure. Examine the structural members near the engine bay. Must come up with a rating system for the customer to evaluate our product compared to the old rig.

### 1.6 PROJECT PLANNING

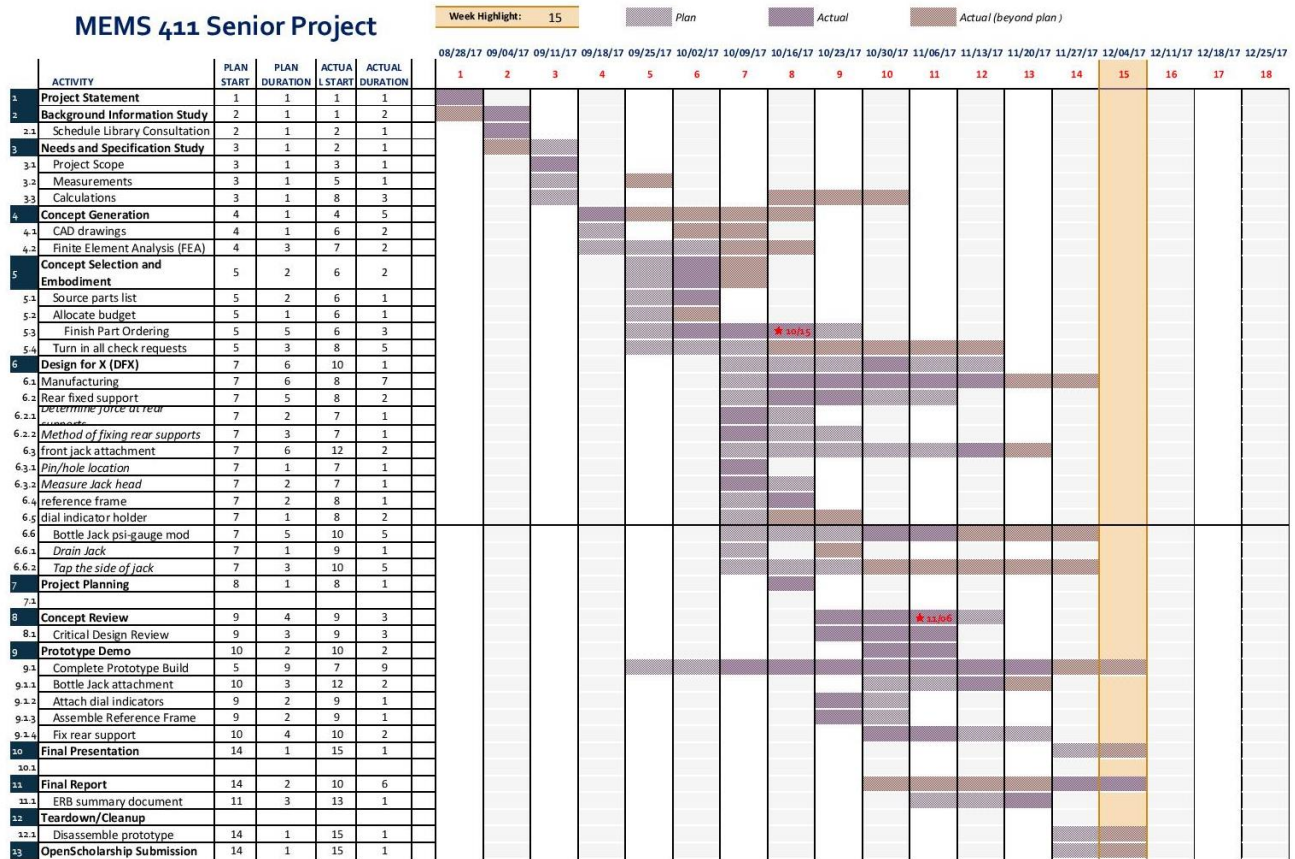

Figure 5 – Gantt chart illustrating the project schedule

### 1.7 REALISTIC CONSTRAINTS

#### 1.7.1 Functional

For the device to be ‘functional’ as defined by our project description, it must be able to test multiple chassis geometries. This puts constraints on the design of our device (i.e. the size, weight, and method). The extent to which we can twist the frame will also be constrained due to the prohibition of yielding.

#### 1.7.2 Safety

The safety of the chassis as well as the user was taken into account when designing this device. The device must apply a specific load to the chassis that creates a deflection; however, it must not push the chassis to the range of plastic deformation and/or fracture. Additionally, the supports need to

withstand the resultant forces throughout the tests. The chassis is quite heavy and needs to be raised off the ground to be tested. If the supports fail, it puts the structural integrity and safety of the user at risk. Therefore, the materials used must be able to withstand the loads incurred during the testing procedure.

### 1.7.3 Quality

The device has to be designed to be consistent throughout all tests performed. This ensures that the results are precise. The results of the testing procedure should also produce accurate results within a desired range of percent error with FEA analysis and hand calculations. The quality of the device must be such that it will not degrade with usage and that it will deliver these requirements.

### 1.7.4 Manufacturing

Our manufacturing constraints for this project consisted mainly of limited resources, and manufacturing experience. We were limited in the amount of available material of the necessary size and the manufacturing methods available, such as injection molding. Additionally our group members' lack of experience in manufacturing and fabrication processes put a strain on our build timeline.

### 1.7.5 Timing

The short project timeline put a strict constraint on our project and what we were able to accomplish. We were unable to troubleshoot properly after manufacturing because of the quickly approaching deadlines.

### 1.7.6 Economic

One of this projects major constraints was the limited budget. With more money, the time spent on this project could be spent creating a top-of-the-line torsional stiffness measuring device. However, the crux we faced is the limited budget. This meant that we had to be very economical when selecting parts and materials to purchase. We were unable to afford measuring devices of higher accuracy as a result. This directly impacts our ability to achieve our performance goals and the accuracy of our results. We planned this project with a contingency factored into our budget plan, so that if the components ordered failed or did not work together, we had funds to buy a replacement part.

### 1.7.7 Ergonomic

To perform a realistic torsional stiffness test on the SAE chassis, a significant load must be applied. The device must be able to apply such a load without requiring strenuous input from the user. Another constraint we took into account was the fact that the FSAE Race Team will not need to use this device throughout the entire year, so we wanted the device to be readily deconstructed and conveniently stored.

### 1.7.8 Ecological

The ecological constraint ties in with the safety constraint. The device cannot break whilst in use. Also, the manufacturing and use of the device does not emit harmful pollutants into the environment. Our prototype's future after the semester lies with the race team, so we will not contribute to pollution through the disposal of our equipment.

### 1.7.9 Aesthetic

There wasn't really a significant aesthetic constraint, as the focus was mainly placed on the functionality, safety, and performance of the device.

### 1.7.10 Life Cycle

The original inspiration for this project was that a lot of race teams will rebuild a new torsional stiffness device each year for a single chassis' specific geometry. The device must be able to withstand multiple years performing multiple test on a variety of chassis each year. It would be wasteful of our time, the race team's time, and resources if the device was only usable for one year.

### 1.7.11 Legal

We could not find any legal constraints for this project, as the device is targeted for a very specific customer populous. It is not a product meant for public reproduction.

## 1.8 REVISED PROJECT DESCRIPTION

This device will measure the torsional stiffness of a FSAE race car frame. Our design will apply a torsional load to the frame while simultaneously providing precise measurements required to calculate the applied load, displacement, angular deflection, and torsional stiffness. Unlike the most popular method of testing torsional stiffness by applying load with a lever, our device twists the frame using hydraulic bottle jacks with an integrated pressure gauge. This aspect enables precise control of the twist, and the pressure gauges provide the capability of load-measurement. The validity of measurements will be assessed by comparing results to theoretical calculations.

## 2 CUSTOMER NEEDS & PRODUCT SPECIFICATIONS

### 2.1 CUSTOMER INTERVIEWS

Table 1 – Customer interviews along with interpreted needs based on customer responses

<b>Customer Data: Torsional Stiffness Measurement Device (TSMD)</b>			
Customer: Jake Kendrick – Wash U Race Team – Frame Lead			
Address: Wash U Race Team			
Date: September 16, 17			
<b>Question</b>	<b>Customer Statement</b>	<b>Interpreted Need</b>	<b>Importance</b>
What wheelbase range does the device need to accommodate?	Maybe 4.5 to 5.5 feet. We should definitely be able to use it for multiple years.	TSMD can test a range of wheelbases	5
What track range does the device need to accommodate?	Maybe 3 to 4.5 feet	TSMD can test a range of track widths	5
Does the device need to be portable?	We need to be able to store it in the cage	TSMD can be packed into a small space	3
Where will the tests be conducted?	Either in the garage or in the loading bay area.	TSMD works on uneven ground.	4
What are some critical areas along the frame where you would like to have displacement measured?	Ideally, we will be able to test multiple locations. You might find those locations through FEA.	TSMD has variable gauge positions	3

-	Probably at least 3 gauges on each side.	TSMD can equip at least 3 dial indicators on each side.	3
Are there any other comments you'd like to make?	It obviously shouldn't break during testing.	TSMD will not deform the frame plastically	4
-	The device should be accurate. We need to use the data to validate our FEA models.	TSMD measures torsional stiffness to within 10% percent difference.	5

## 2.2 INTERPRETED CUSTOMER NEEDS

**Table 2 – Interpreted customer needs based on the customer's responses. Needs of importance 5 are of critical importance. Needs of importance 1 are of least importance.**

Need Number	Need	Importance
1	TSMD can test a range of wheelbases	5
2	TSMD can test a range of track widths	5
3	TSMD can be packed into a small space	3
4	TSMD works on uneven ground.	4
5	TSMD has variable gauge positions	3
6	TSMD can equip at least 3 dial indicators on each side.	3
7	TSMD will not deform the frame plastically	4
8	TSMD measures torsional stiffness to within 10% percent difference.	5

## 2.3 TARGET SPECIFICATIONS

**Table 3 – Metrics quantifying customer's interpreted needs and design team requirements**

Metric Number	Associated Needs	Metric	Units	Acceptable (value or range)	Ideal	Source
1	1	Wheelbase accommodation	ft	>5.2	> 5.4	Customer Need
2	2	Track accommodation	ft	>4.8	>4.2	Customer Need
3	5	Number of positions per side	integer	>1	3	Customer Need
4	6	Force	lbs	>80	< 100	Design Team Requirement

5	8	% Difference	%	10	<10	Design Team Requirement
5		Weight of TSMD	lbs	<400	<300	Design Team Requirement
6	4	Surface slope angle	degrees	>0.2	<0.6	Customer Need
7		Cost of parts	\$	<230.40	<200	Accounting Requirement
8		Assemble/disassemble time	minutes	<15	10	Design Team Requirement
9		Testing time	minutes	<30	<20	Design Team Requirement
10		Experimental footprint	ft <sup>2</sup>	<24	21	Design Team Requirement
11	3	Storage footprint	ft <sup>2</sup>	<25	<20	Customer Need
12	7	Deformation	in	< 1.5	<1	Customer Need

### 3 CONCEPT GENERATION

#### 3.1 FUNCTIONAL DECOMPOSITION

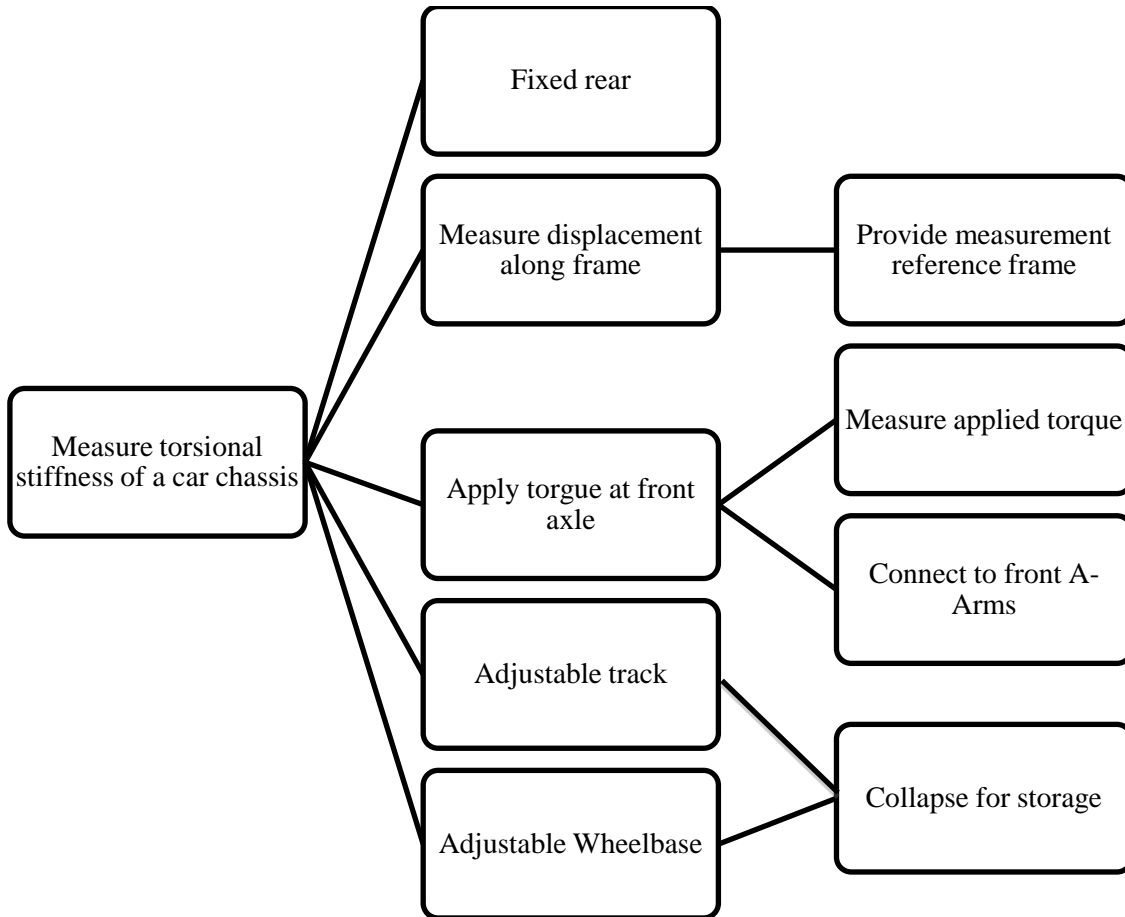

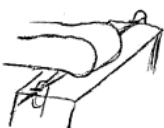



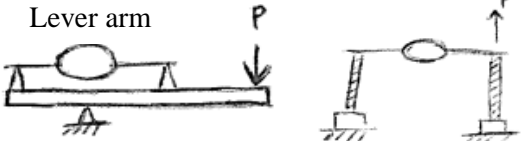

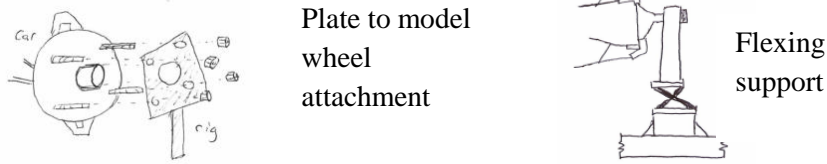
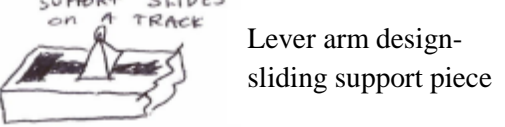
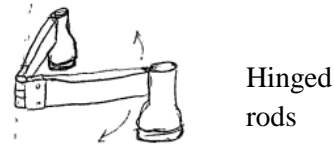

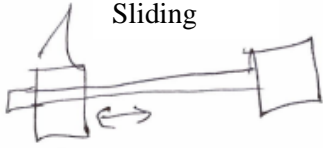

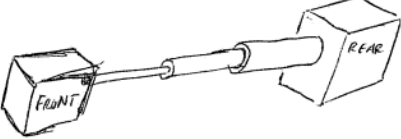
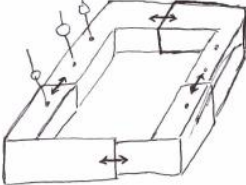

Figure 6 – Figure shows the functional decomposition of the torsional stiffness measuring device

#### 3.2 MORPHOLOGICAL CHART

Table 4 – Design challenges and potential solutions

<p><b>Fix rear</b></p>	 <p>Independent supports</p>  <p>Curved piece 'hugs' a circular upright feature</p>	 <p>G-clamp to table</p>	 <p>Plate to model wheel attachment</p>
------------------------	---	---	---

<p><b>Measure displacement along frame</b></p>	 <p>Dial Indicator      Metric on jack      Side wall for rotation angle</p>			
<p><b>Provide measurement reference frame</b></p>	 <p>Hang from frame      Tabletop      Standing frame</p>		<p>Ground could be used as a reference frame</p>	
<p><b>Apply torque at front</b></p>	 <p>Lever arm      Jack</p>			
<p><b>Measure applied torque</b></p>	 <p>scales      Load cell</p>		<p>Calculate applied torque for lever arm design</p>	
<p><b>Connect to front A-arms</b></p>	 <p>Car      Plate to model wheel attachment      Flexing support</p>		<p>G-clamps could be used with lever arm design</p>	
<p><b>Adjustable track</b></p>	 <p>SUPPORT SLIDES ON TRACK      Lever arm design-sliding support piece</p>		<p>Jacks are inherently adjustable</p>	
	 <p>Hinged rods</p>			

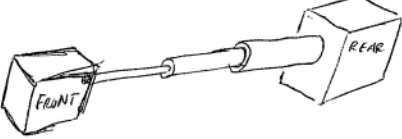
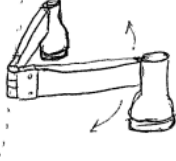
<p><b>Adjustable wheelbase</b></p>	 <p>Sliding</p>  <p>Separate parts</p>  <p>Extendable /collapsible rod</p>	
<p><b>Collapses for storage</b></p>	 <p>Standing frame collapses into itself</p>  <p>Legs of frame for reference frame fold with hinge</p>  <p>Extendable /collapsible rod</p>  <p>Hinged rods</p>	<p>If front and rear are separate, then it is considered to be collapsible</p>

**3.3 CONCEPT #1 – “SIMPLISTIC RIG”**

The rig applies torque to the frame through the lever arm. This torque can be measured if the applied load and the geometry of the system are known. The frame is clamped to the rig using g-clamps and the front and rear, where the front and rear are separated into two independent assemblies. The rear of



the frame is fixed to a table-like surface. Dial indicators are used to measure displacement at locations of interest along the frame; the ground is used as a reference frame for these measurements.

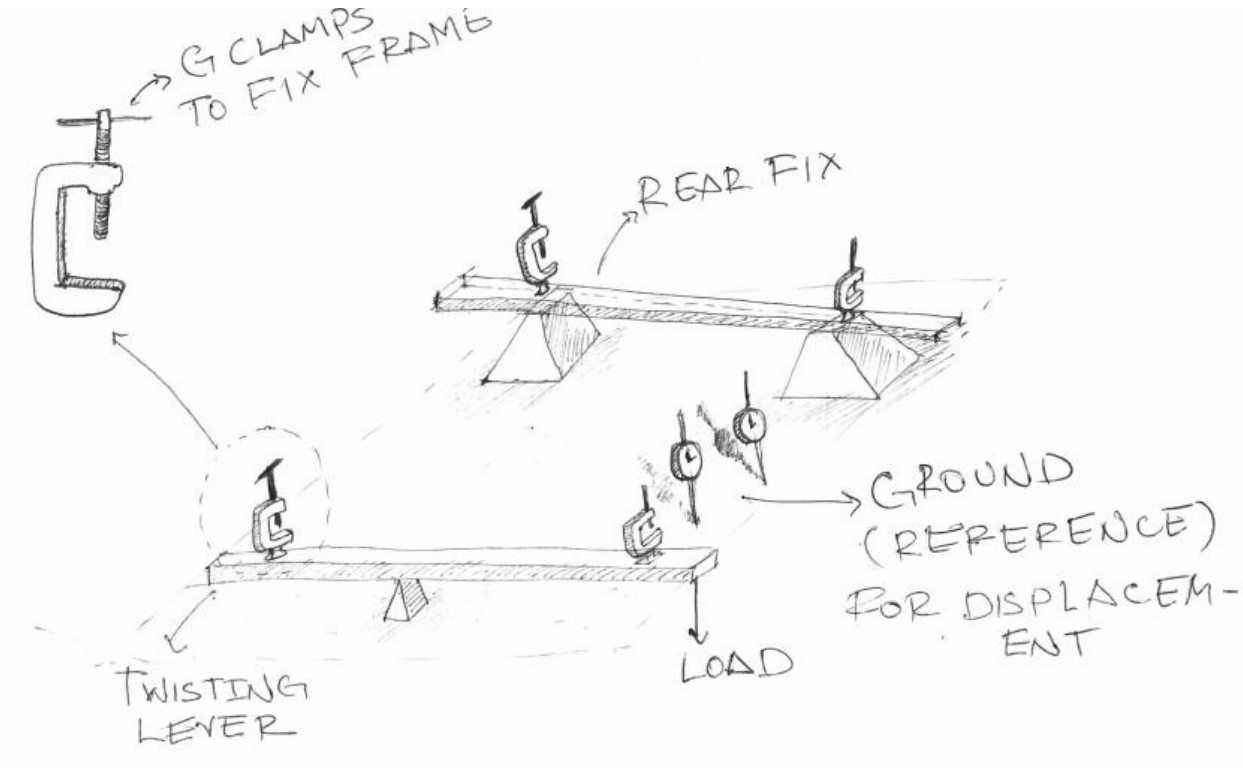

Figure 7 – “Simplistic Rig” concept diagram

Design Challenge Solutions:

1. Rear is fixed to two separate supports with a plate modeling the wheel attachment system
2. Dial indicators
3. Ground as reference frame
4. Lever arm
5. Calculate applied torque
6. G-clamps
7. G-clamps on lever arm
8. Separate parts
9. N/A

### 3.4 CONCEPT #2 – “GROUNDED JACK & GAUGE”

The following image features a bottle jack modified with a pressure gauge. Knowing the diameter of the piston rod within the bottle jack, we can calculate the applied force from the pressure readout. The reference frame of this concept is very versatile in terms of accommodating a variety of frame geometries. The rear is fixed using plates modeling the wheel attachment mechanism. These plates are cast in concrete to resist reaction forces.

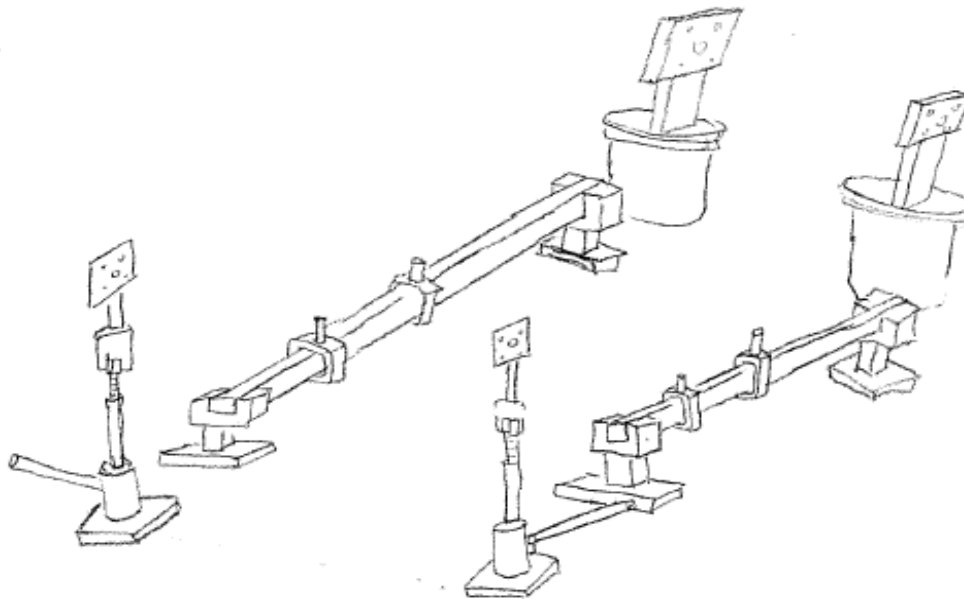

Figure 8 – “Grounded Jack & Gauge” concept diagram

#### Design Challenge Solutions:

1. Rear is fixed to separate supports attached with a plate modeling wheel attachment
2. Dial indicators
3. Standing reference frame
4. Jacks
5. Pressure gage modification to jack
6. Plate to model wheel attachment
7. N/A
8. Separate parts
9. N/A

### 3.5 CONCEPT #3 – “HANGING REFERENCE FRAME RIG”

The rig applies torque to the frame through a lever arm. The front A-arms connect to sliding supports on the lever arm. The attaching action in the front models that of the wheel and upright. The displacement along the frame is measured with dial indicators attached to a reference frame hanging from the frame itself. The rear of the frame is fixed to two independent supports with a plate to model wheel attachment to uprights.

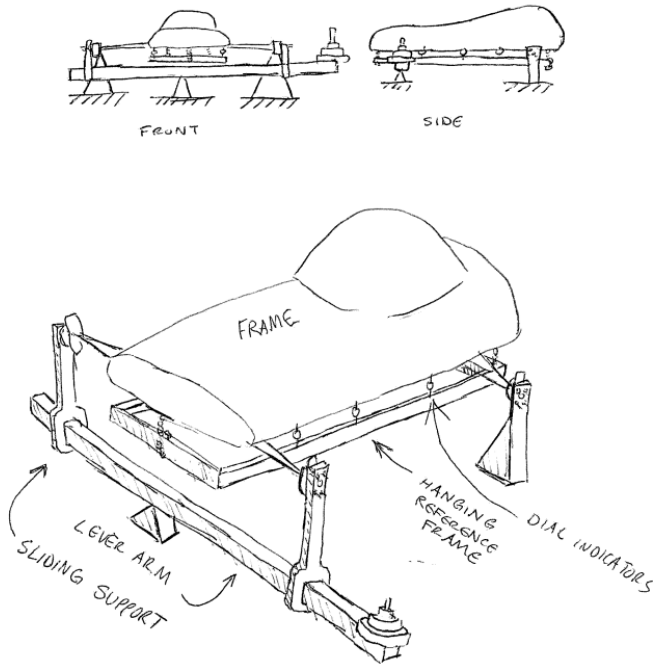

Figure 9 – “Hanging Reference Frame Rig” concept diagram

#### Design Challenge Solutions:

1. Rear is fixed to two separate supports with a plate to model wheel attachment method
2. Dial indicators
3. Hanging reference frame
4. Lever arm
5. Calculate torque
6. Plate to model wheel attachment method
7. Sliding support piece
8. Separate parts
9. N/A

### 3.6 CONCEPT #4 – “FRANKENSTEIN RIG”

The rig applies torque through two jacks placed upon scales. The reference frame is adjustable to accommodate a range of frame geometries. The displacement is measured using dial indicators. The rear

is fixed with G-clamps to a table, and the front uprights are mated to the jacks using a curved piece.

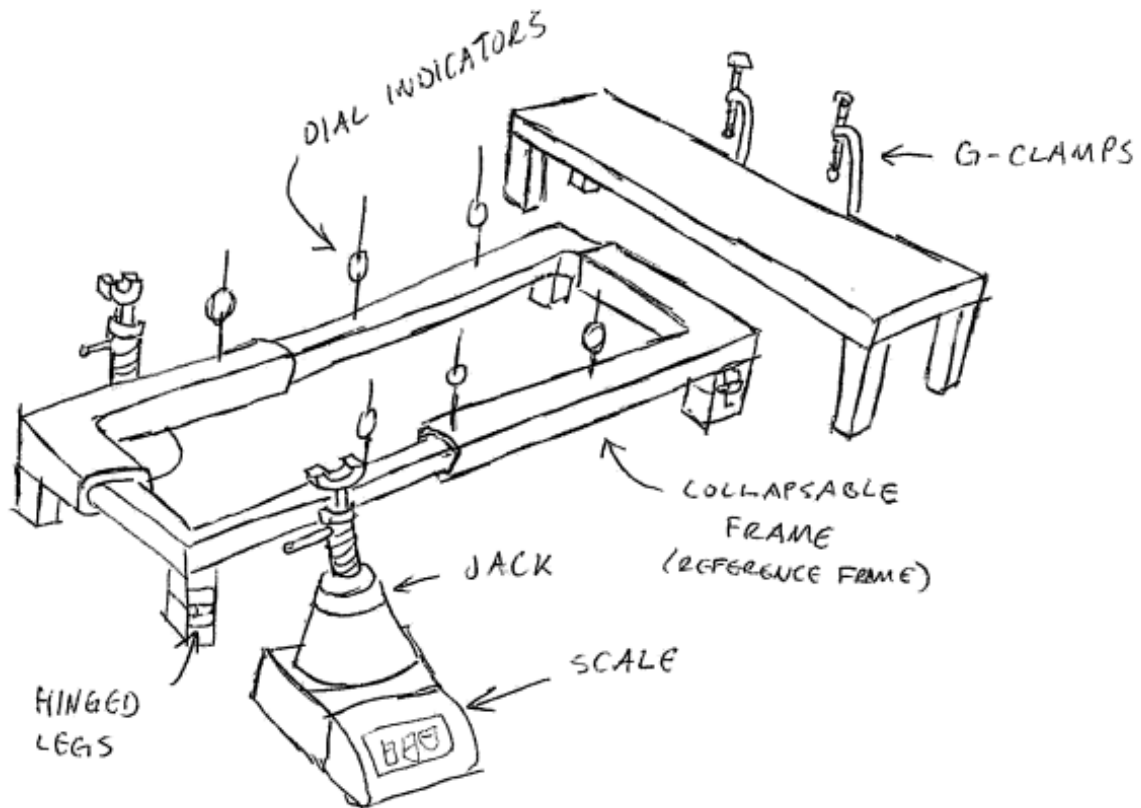

Figure 10 – “Frankenstein Rig” concept diagram

Design Challenge Solutions:

1. Rear is fixed to a table using g-clamps
2. Dial indicators
3. Standing reference frame
4. Jacks
5. Scales
6. Curved piece ‘hugs’ a circular upright feature
7. N/A
8. Separate parts
9. Standing reference frame collapse into self

### 3.7 CONCEPT #5 – “TABLETOP SCREW JACK 5000 TORSIONAL STIFFNESS TESTER”

The rig applies torque through two jacks placed upon scales. The displacement is measured using dial indicators and a metric on the screw jack. The uprights are attached to the rig using a plate modeling the wheel-attachment system. The entire rig is placed upon a flat tabletop which acts as a reference frame

for the displacement measurements.

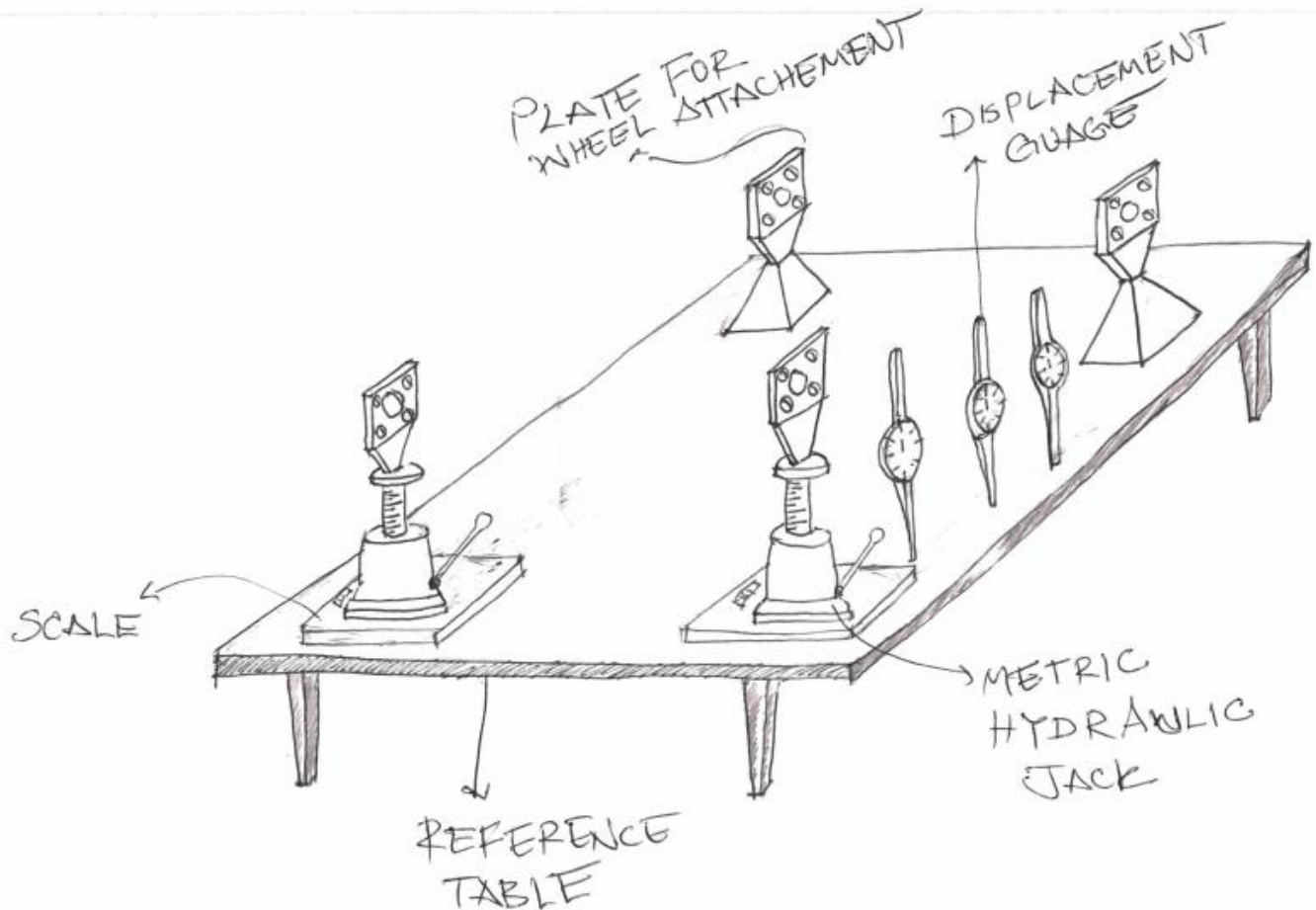

Figure 11 – “Tabletop Screw Jack 5000 Torsional Stiffness Tester” concept diagram

Design Challenge Solutions:

10. Rear is fixed to separate supports attached with a plate modeling wheel attachment
11. Dial indicators and metric on jack
12. Tabletop
13. Jacks
14. Scales
15. Plate to model wheel attachment
16. N/A
17. Separate parts
18. N/A

### 3.8 CONCEPT #6 – “TABLETOP LEVER ARM 5000 TORSIONAL STIFFNESS TESTER”

The rig applies torque to the frame using a lever arm. The uprights attach to the rig through plates modeling the wheel attachment system. Dial indicators are placed at locations of interest along the frame to measure displacement. A flexure pivot is placed on the lever arm to assist measurement. There is a sliding mechanism on the lever arm to accommodate a range of frame geometries. The rig is placed on a

tabletop that acts as a reference for displacement measurements.

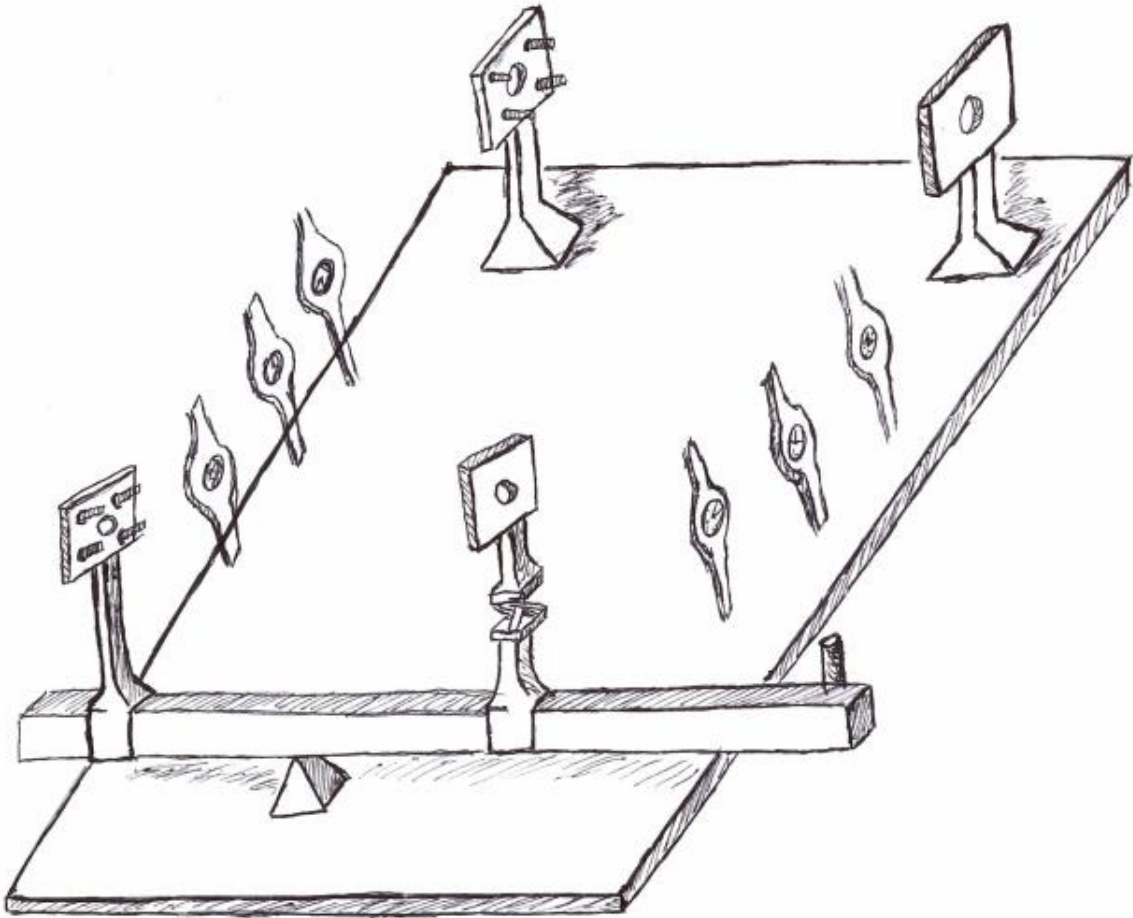

Figure 12 – “Tabletop Lever Arm 5000 Torsional Stiffness Tester” concept diagram

Design Challenge Solutions:

1. Rear is fixed to separate supports attached with a plate modeling wheel attachment
2. Dial indicators
3. Tabletop
4. Lever arm
5. Calculate torque
6. Plate to model wheel attachment and flexing support
7. Sliding support piece
8. Separate parts
9. N/A

## 4 CONCEPT SELECTION

### 4.1 CONCEPT SCORING MATRIX

The criteria for the concept selection matrix were weighted according to an analytical hierarchical process (see Fig. 13). Each criterion was compared to all other criteria in a one-one contest. Each competing criterion was placed at one end of a scale ranging from 10 to 0 to 10, where 10 on the left side of the scale signifies that the criterion on the left side entirely ‘outweighs’ the criterion on the right side of the scale (i.e. the right criterion is not at all important and the left criterion is extremely important). Each row was totaled. Then, the row total was divided by the sum of all the row totals to produce the weight percentage.

	Mechanical Safety	Cost of components	Collapsability	Ease of use	Variable track accomodation	Variable wheelbase accomodation	Realistic load capability	Manufacturability	Frame-rig connection stability	Row Total	Weight Value	Weight (%)	
Mechanical safety	1.00	4.00	6.00	5.00	2.00	2.00	1.00	8.00	6.00	35.00	0.17	16.52%	
Cost of components	0.25	1.00	9.00	7.00	0.20	0.20	0.50	0.33	0.25	18.73	0.09	8.84%	
Collapsability	0.17	0.11	1.00	1.00	0.13	0.13	0.11	0.14	0.25	3.03	0.01	1.43%	
Ease of use	0.20	0.14	1.00	1.00	0.13	0.13	0.13	0.13	0.13	2.97	0.01	1.40%	
Variable track accomodation	0.50	5.00	8.00	8.00	1.00	1.00	5.00	6.00	4.00	38.50	0.18	18.17%	
Variable wheelbase accomodation	0.50	5.00	8.00	8.00	1.00	1.00	5.00	6.00	4.00	38.50	0.18	18.17%	
Realistic load capability	1.00	2.00	9.00	8.00	0.20	0.20	1.00	4.00	6.00	31.40	0.15	14.82%	
Manufacturability	0.13	3.00	7.00	8.00	0.17	0.17	0.25	1.00	0.17	19.88	0.09	9.38%	
Frame-rig connection stability	0.17	4.00	4.00	8.00	0.25	0.25	0.17	6.00	1.00	23.83	0.11	11.25%	
<b>Column Total:</b>											<b>211.84</b>	<b>1.00</b>	<b>100%</b>

Figure 13 - Analytical hierarchical selection process for the criteria of the concept selection matrix

	Weight (%)	Rating	Weighted	Rating	Weighted	Rating	Weighted	Rating	Weighted	Rating	Weighted	Rating	Weighted
Selection Criterion	Weight (%)	Rating	Weighted	Rating	Weighted	Rating	Weighted	Rating	Weighted	Rating	Weighted	Rating	Weighted
Mechanical safety	16.52	2	0.33	3	0.50	2	0.33	1	0.17	2	0.33	2	0.33
Cost of components	8.84	4	0.35	2	0.18	2	0.18	1	0.09	1	0.09	4	0.35
Collapsability	1.43	2	0.03	3	0.04	2	0.03	2	0.03	3	0.04	2	0.03
Ease of use	1.4	2	0.03	3	0.04	2	0.03	2	0.03	3	0.04	2	0.03
Variable track accomodation	18.2	2	0.36	5	0.91	2	0.36	3	0.55	2	0.36	2	0.36
Variable wheelbase accomodation	18.2	3	0.55	3	0.55	3	0.55	3	0.55	3	0.55	3	0.55
Realistic load capability	14.8	2	0.30	3	0.44	2	0.30	3	0.44	3	0.44	2	0.30
Manufacturability	9.38	2	0.19	1	0.09	2	0.19	2	0.19	3	0.28	3	0.28
Frame-rig connection stability	11.3	2	0.23	3	0.34	3	0.34	2	0.23	3	0.34	3	0.34
<b>Total score</b>		2.360		3.090		2.296		2.260		2.478		2.567	
<b>Rank</b>		<b>4</b>		<b>1</b>		<b>5</b>		<b>6</b>		<b>3</b>		<b>2</b>	

Figure 14 - Concept selection matrix

### 4.2 EXPLANATION OF WINNING CONCEPT SCORES

#### Grounded Jack & Gauge

The concept features two modified hydraulic bottle jacks and two separated reference frames spanning the wheelbase. The bottle jacks will have pressure gauges attached to them so that we can

determine the applied force from a simple calculation involving the pressure readout and the area of the ram. This allows us to avoid buying scales, which are apparently extremely expensive (who knew?). The separated reference frames allow us to save money on materials while still accommodating a plethora of frame geometries. The track span, for example, is limitless (explaining the 5 rating). Since this rig is grounded, it is safer than the tabletop rigs. The tabletop introduces more instability and a greater potential energy. This grounded design will sit very low to the ground. In the event of rig failure, the damage to the frame would be minimal. This design will be challenging to bring to life because of the bottle jack modifications. That is why you see the 1 rating for manufacturability.

### **4.3 EXPLANATION OF SECOND-PLACE CONCEPT SCORES**

#### **Tabletop Lever Arm Rig**

This concept is very similar to the top ranked concept. The only difference is the method of applying torque to the frame. The concept is favorable in one criterion compared to the Tabletop Screw Jack Rig: cost of components. Using a lever arm to apply torque avoids the expense of the screw jacks and scales. The tradeoff, however, surfaces in manufacturability. The Tabletop Lever Arm Rig is a little more challenging to manufacture. The lever arm design is also not quite as accommodating to variable track (in the front) because the track is restricted to the length of the lever arm. The screw jacks are separate bodies and can therefore be moved at any distance necessary to accommodate track. Track accommodation is tied (with wheelbase accommodation) for the highest weighted criterion. The lever arm requires the placement of weights. This activity introduces safety hazards, so the concept is ranked lower in mechanical safety (the third highest weighted criterion). Finally, the lever arm cannot simulate realistic loads as well as the screw jack design. This criterion is ranked third highest. The combination of these characteristics explains the success of the Tabletop Screw Jack.

### **4.4 EXPLANATION OF THIRD-PLACE CONCEPT SCORES**

#### **Tabletop Screw Jack Rig**

This concept was the reference concept during the rating process. The cost of components for this design ranked at 3 because the steel involved. The costs come from the jacks and the scales. Compared to other leading concepts, this is probably only marginally better. This concept seems to combine all of the best parts of the other concepts. For this reason, this concept might have been more deserving of the name “The Frankenstein Rig.” This concept ranks very consistently across all criteria, which is why it serves as a good reference concept. However, the cost of this concept is outrageous because of the inclusion of two scales. Scales are very expensive.

### **4.5 SUMMARY OF EVALUATION RESULTS**

Evaluating the results of the concept selection process, we see that our preferred, more thoughtful concepts (the Tabletop Screw Jack, the Tabletop Lever Arm, and the Grounded Jack & Gauge) prevailed as the best portions according to the weighted criteria. As expected, the Grounded Jack & Gauge concept triumphed as the superior design. The other three concepts ranked predictably as well. The Frankenstein Rig, with two bottle jacks and two scales, was the worst concept primarily due to its outrageous cost and



mechanical safety (criteria weighted 8.84% and 16.52% respectively). Finally, the Simplistic Rig outranked the Hanging Reference Frame Rig because of the cost of the components. The Simplistic Rig was, in fact, the least expensive option. The agreement between the results and expectations verifies the criteria weighting system.

Looking forward from here, we can now focus on manufacturing and part ordering according to the specifications of the winning concept: The Grounded Jack & Gauge.

## 5 EMBODIMENT & FABRICATION PLAN

### 5.1 ISOMETRIC DRAWING WITH BILL OF MATERIALS

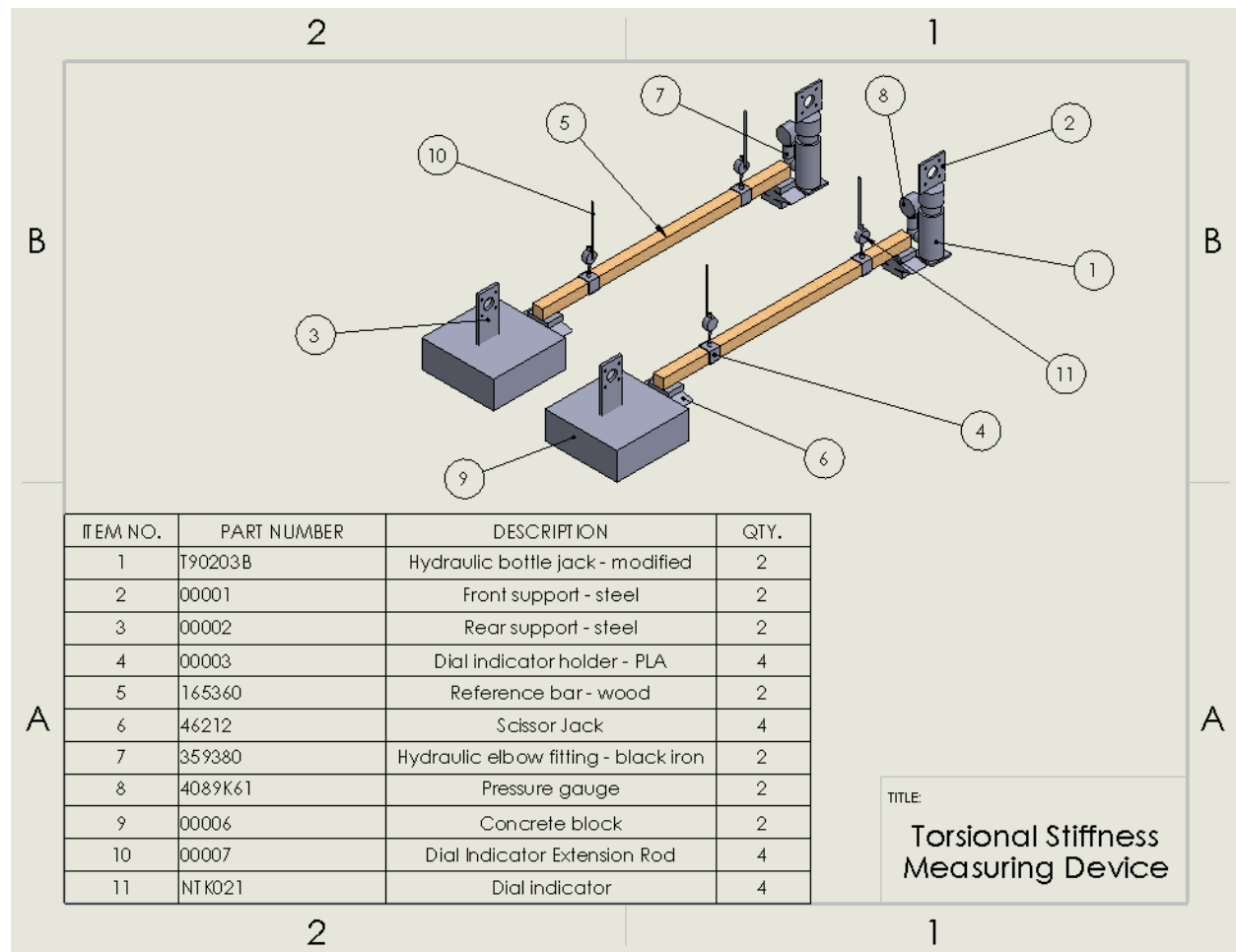

Figure 15 – Isometric drawing with bill of materials

## 5.2 EXPLODED VIEW

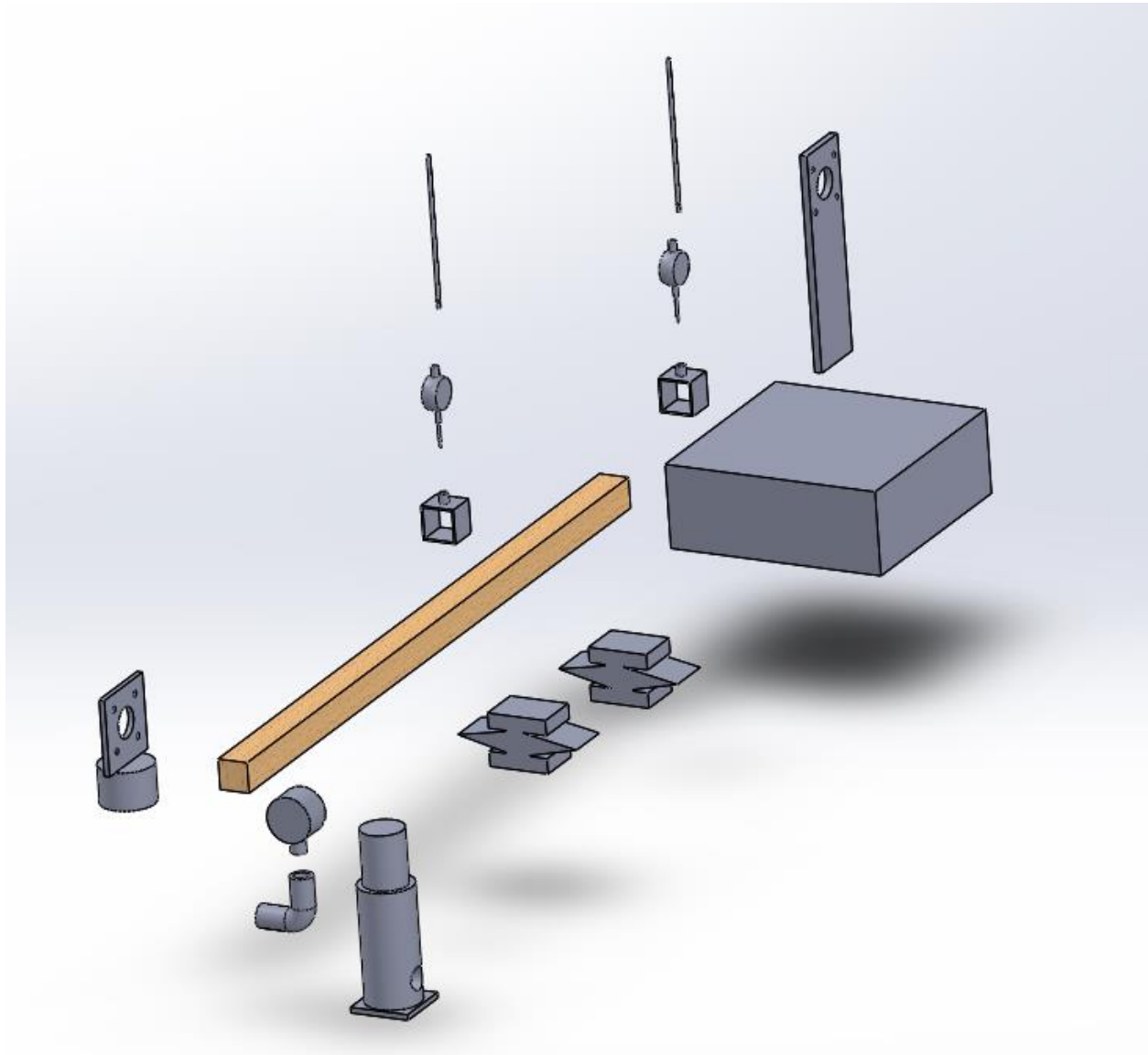
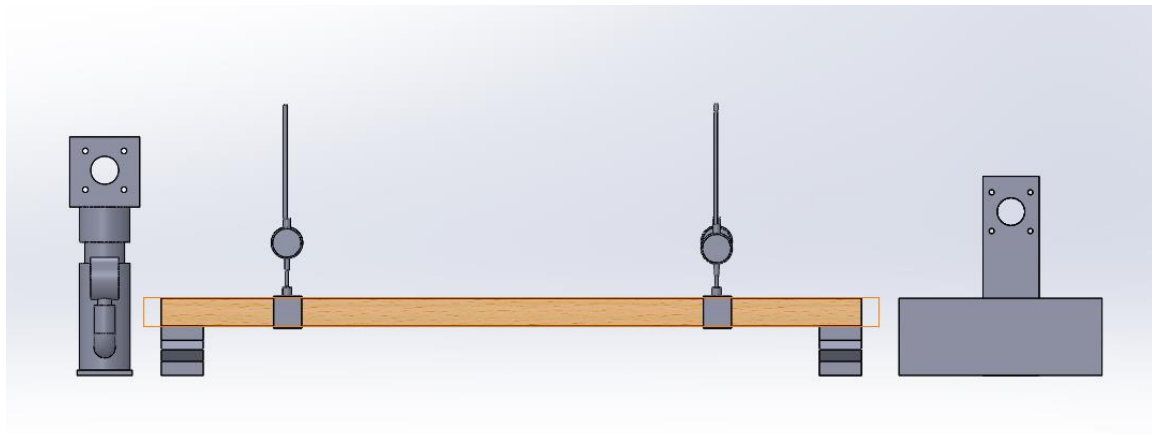
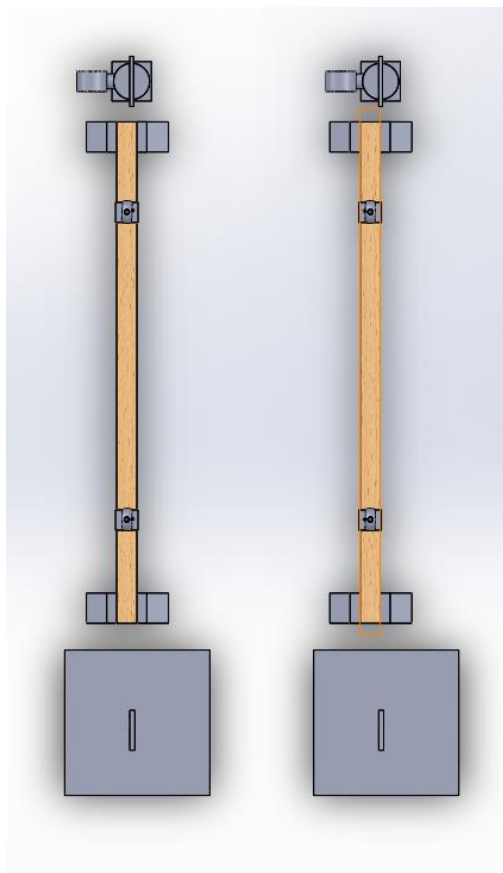

Figure 16 – Exploded view of torsional stiffness measuring device

### 5.3 ADDITIONAL VIEWS



(a)



(b)

Figure 17 – (a) Right-side view of torsional stiffness measuring device. (b) Top view of device

## 6 ENGINEERING ANALYSIS

### 6.1 ENGINEERING ANALYSIS RESULTS

#### 6.1.1 Motivation

This analysis is critical to the manufacturing process. Without verification that the rear supports will not yield, and without an accurate estimate of the required weight to fix the rear supports, we cannot construct our rig. Through this engineering analysis, we expect to acquire this information. With this information, we will be able to begin manufacturing the rig.

#### 6.1.2 Summary Statement of the Analysis

The goal of the engineering analysis is to determine the reaction forces at the rear supports in response to an applied torque (assuming equilibrium conditions). Essentially, we are seeking the force at the rear supports required to maintain equilibrium. First, we drew a free body diagram of the vehicle's frame under load applied by our device (see figure 4).

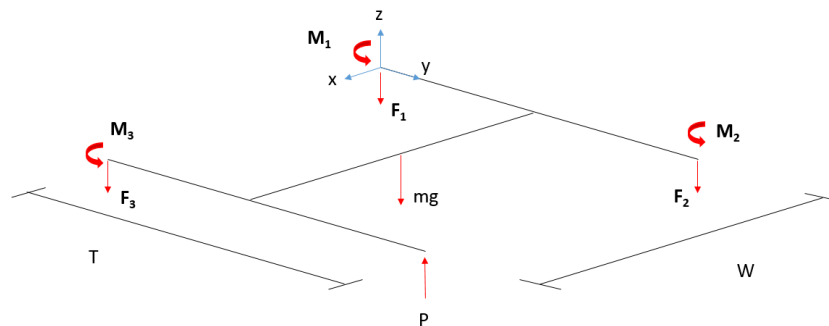
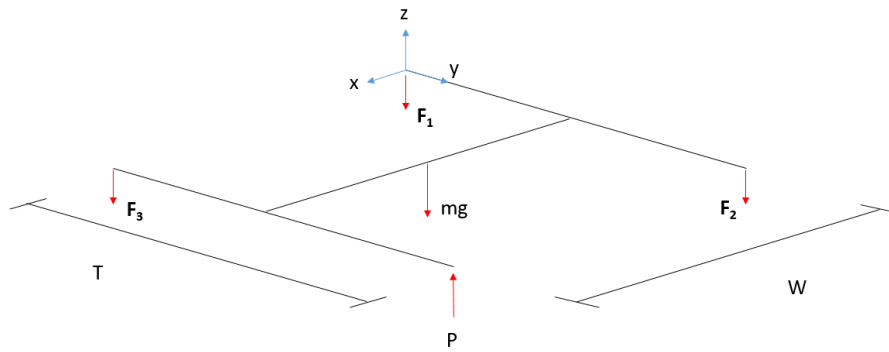

**Figure 18 - Free Body Diagram of simplified frame and complex solution approach (used fixed joints)**

Applying a force balance and a moment balance about the back right hub, we tried to express the reaction forces at the rear in terms of known forces. We assume that the center of mass is at the geometric center of the simplified frame. We have also assumed that the rear track is exactly as large as the front track. Unfortunately, we were left with three equations and nine unknowns. The equations are as follows:

$$\begin{aligned}\sum M_x &= T(P - F_2 - mg/2) + M_{1x} + M_{2x} + M_{3x} = 0 \\ \sum M_y &= W(mg/2 + F_3 - P) + M_{1y} + M_{2y} + M_{3y} = 0 \\ \sum F_z &= P - mg - F_1 - F_2 - F_3 = 0\end{aligned}$$

Clearly, this system is indeterminate, so we had to make a simplifying assumption to complete the derivation: the hubs are connected to pin joints. This eliminated three unknowns and made the system of equations solvable. The following figure shows our simplified free body diagram:



**Figure 19 – Free Body Diagram of simplified farm and simplified solution approach (using pin joints).**

With these simplifications, the system equations become

$$\begin{aligned}\sum M_x &= T (P - F_2 - mg/2) = 0 \\ \sum M_y &= W (mg/2 + F_3 - P) = 0 \\ \sum F_z &= P - mg - F_1 - F_2 - F_3 = 0\end{aligned}$$

Solving the system of equations, we find that

$$\begin{aligned}F_3 &= P - mg/2 \\ F_2 &= P - mg/2 \\ F_1 &= -P\end{aligned}$$

We then transition to FEA via Solidworks to predict the rear reaction forces ( $F_1$  and  $F_2$ ) using a Solidworks assembly of the 2015 frame (provided by the Wash U Race Team). After running the analysis, we see that the frame does not yield in any areas, verifying the load magnitude of 100 lbs (see figure 20).

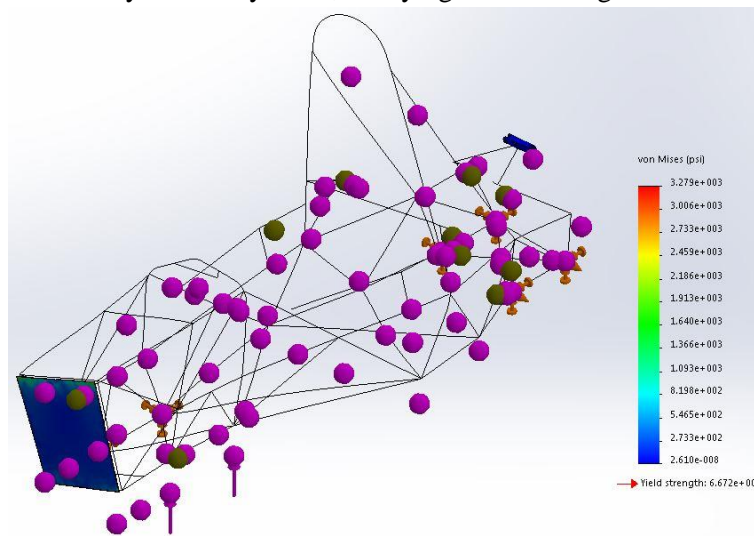

**Figure 20 – von Mises stress results from Solidworks FEA.**

Looking at the displacement associated with this applied load (see figure 21), we can see that the frame deflects less than an inch in the areas that we will be observing.

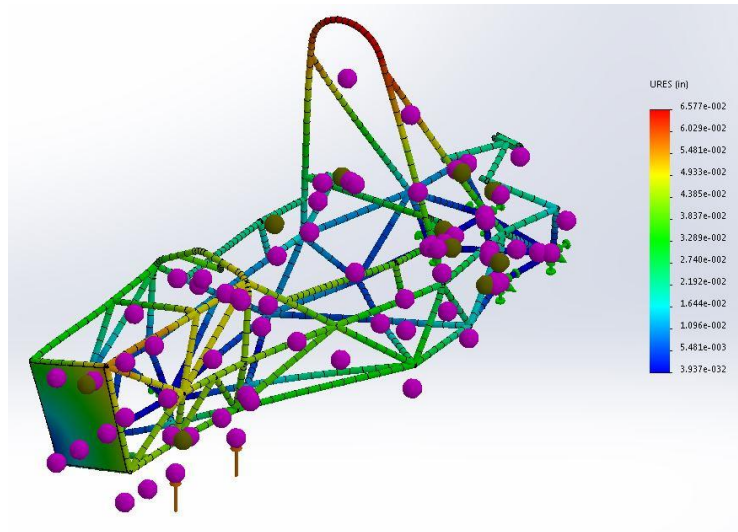

**Figure 21 – Displacement results from Solidworks FEA.**

Next, we look at the reaction forces at the fixed joints (see figure 22) and extrapolate to find the reaction forces  $F_1$  and  $F_2$ . This will allow us to determine the weight required to keep the rear fixed during testing.

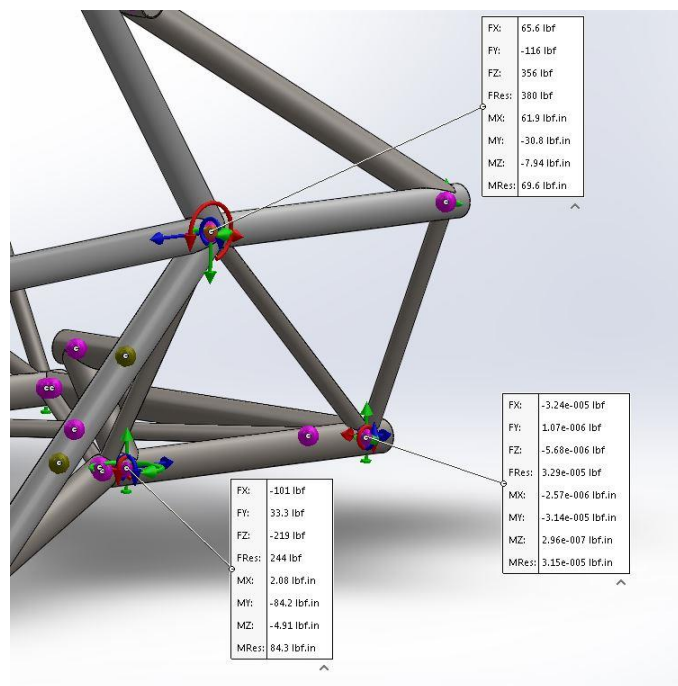

**Figure 22 – Resultant force at rear joints from Solidworks FEA.**

Finally, we look at the rear support's response to the load calculated to determine if it yields (see figure 23).

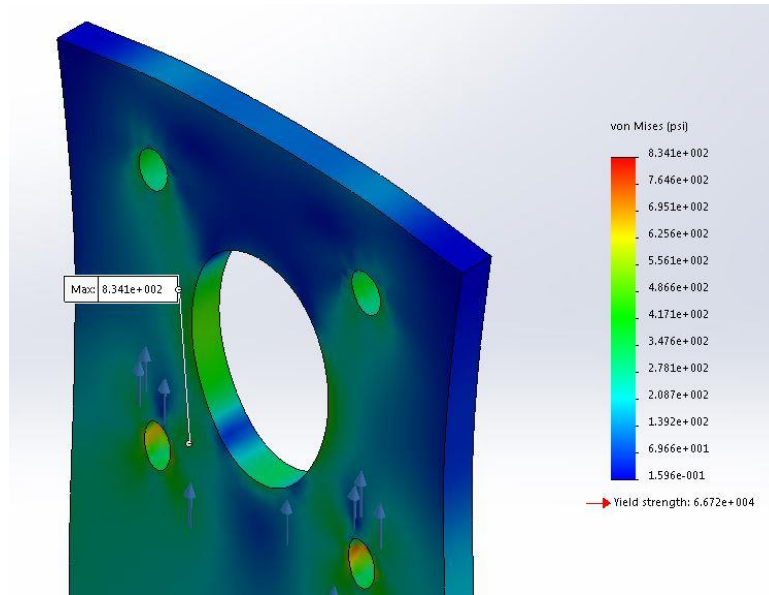

Figure 23 – von Mises stress results of the rear support from Solidworks FEA.

### 6.1.3 Methodology

This analysis was performed using a simulation study in Solidworks because the hand calculations were too simplified to give accurate results. The race team gave us Solidworks files of the 2016 car frame, and we simulated our test procedure using a static study. We fixed three joints and applied an upward force with a conservative magnitude of 100 pounds (hoping to remain in the elastic deformation region) at the front on the frame. We were then able to determine the reaction forces at the eight fixed joints in the rear (four per side). The Solidworks file does not contain the A-arms and the hub that we will be using to mount the frame to the measurement device. Drawing a free body diagram of the region leads to the conclusion that the reaction force at the rear support can be determined by a simple sum of the vertical forces. After finding the reaction forces at the rear supports, we were then able to analyze the performance of the rear support under these conditions.

### 6.1.4 Results

The reaction forces at the rear supports in response to an applied force of 100 pounds were determined to be  $F_1 = -38.5$  pounds (downward) and  $F_2 = 86.6$  pounds (upward). The magnitude of these forces makes sense considering the magnitude of the applied force; we would not expect the reaction force at any support to be greater than the applied force. The rear supports reached a maximum stress value 80 times less than the yield strength.

### 6.1.5 Significance

The results indicate that we need at least 83 pounds to secure the rear supports during the test procedure. This is reassuring considering our current design employs a concrete block (density of 145 pounds per cubic foot) to secure each rear support. With a block of 5.5 inches in height, we would only need a square base area with 13.6 inch side length. Additionally, we discovered that the steel rear supports would not yield on the reaction forces. This verifies our design selections to this point, and we can now begin constructing the device.

## 6.2 PRODUCT RISK ASSESSMENT

### 6.2.1 Risk Identification

#### 1. Risk Name: FEA is inaccurate

Description: This risk could occur if we overlook some structural/mechanical aspects of the chassis and/or the torsion testing system. The FEA analysis could be inaccurate if the system yields in some aspect.

Impact: 4, this risk could result in chassis design failures and could also result in point deductions in competition if the theoretical and actual results of torsion testing do not match up.

Likelihood: 3, it is possible to occur; not extremely likely but not extremely unlikely.

#### 2. Risk Name: Jack Attachment yields under load

Description: Using the FEA, we will be able to have a general estimate of the applied load that would cause yielding in the part that attaches to the bottle jack and hub.

Impact: 3, the jack and this attachment are putting the chassis in torsion. Should this part break, the load will not be translated to the chassis.

Likelihood: 2, based on the geometry and the materials used it is less likely to occur.

#### 3. Risk Name: Chassis yields under load

Description: The FEA will find the yield stress/strain of the chassis and this will give us a maximum applied load to avoid breaking the chassis. The chassis could yield if our FEA/calculations are inaccurate and we apply a load greater than the acceptable loads the body can withstand.

Impact: 5, the chassis breaking completely defeats the purpose of our device, to optimize the design of the chassis.

Likelihood: 1, this is very unlikely to occur as the chassis is designed to withstand much greater loads than what we are subjecting it to.



4. Risk Name: Rear support slips out

Description: FEA will determine the necessary counterbalance weight to keep the body in equilibrium (Reaction forces). The rear could slip out due to inadequate structural design to counterbalance the torque applied to the front axle.

Impact: 2, if the rear support were to “slip” it would only slightly affect the results, but would not cause bodily harm to anyone.

Likelihood: 1, this is highly unlikely to occur as the rear supports will be fixed to the chassis directly.

5. Risk Name: Bottle Jack fails due to modification

Description: The bottle jack could fail (leak hydraulic fluid/give inaccurate pressure readings) due to the modifications we have made. In order to attach a pressure gauge, we had to drill and tap through the external shell and into the reservoir. This may affect the structural integrity. We can make sure nobody stands in close proximity of the bottle jack.

Impact: 4, many things can result from the failure of the bottle jack (explosion, incorrect readings, etc).

Likelihood: 4, the procedure of modifying the bottle jack to accommodate the pressure gauge isn't well-defined.

6. Risk Name: Rear attachment yields under load

Description: Similar to the jack attachment to the front axle, the rear support could also fracture or yield under load. Using Finite Analysis in SOLIDWORKS we can predict the threshold of stress and strain for this part, and determine the maximum load that can be applied.

Impact: 3, this could possibly harm someone (unlikely) but it would have a greater impact on the functionality of our device.

Likelihood: 2, this is unlikely to occur based on the load we are applying and the geometry of the part/device.

### 6.2.2 Risk Heat Map

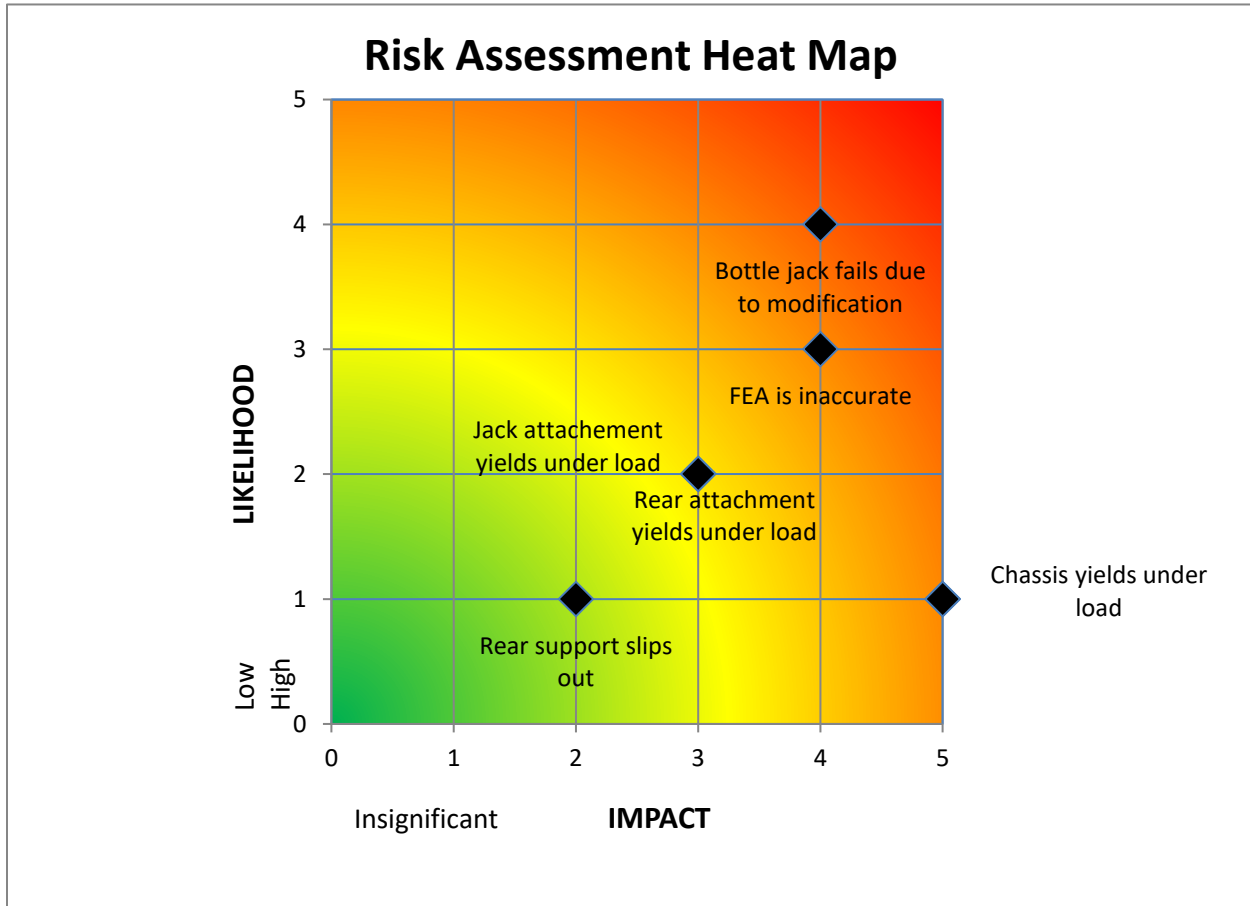

Figure 24 - Heat map illustrating the severity and likelihood of different risks

### 6.2.3 Risk Prioritization

Figure 24 illustrates the severity and likelihood of each risk. The most severe risk is the yielding of the chassis. This is because the customer specifically clarified that the test should be non-destructive. Causing the frame to yield would directly conflict with the customer's requests. Fortunately, that is very unlikely due to the small loads we will be applying. The most likely risk is the failure of the bottle jack. This is because the modification process is fairly complicated, so there is a relatively high likelihood for error. This error could lead to the bottle jack's failure. This consequences would be fairly severe considering the cost and time sensitivity of the project as well as the difficulties presented when replacing the bottle jack. The risk of an inaccurate FEA is fairly likely because of the difficulties involved with running static studies on assemblies as complex as Wash U Racing's frames. Its consequences are potentially severe because if we underestimate the weight needed to secure the rear, then our test accuracy would be compromised. The bottle jack failure, inaccurate FEA, and yielding of chassis risk are therefore prioritized, and we will focus our efforts to ensure that they are not realized.

## 7 DESIGN DOCUMENTATION

### 7.1 PERFORMANCE GOALS

For this prototype, we set six performance goals to work towards over the course of this semester. First, the device must apply a load that causes a displacement in the chassis strictly within the elastic torsional strain range. Second, the device must be designed in a way such that user(s) can assemble or disassemble it within 15 minutes. Third, the test that the device performs on the chassis can be replicated at least three times, with minimal percent difference between each test. Fourth, the device provides precise measurements of displacement and the applied load. Fifth, the device can accommodate test on at least two frames of varying geometry. Last, the experimental value of the torsional stiffness is within a range of 10% error compared to the FEA results and hand-calculations.

### 7.2 WORKING PROTOTYPE DEMONSTRATION

#### 7.2.1 Performance Evaluation

In review of the six performance goals we set for our project, we met all but one. We were able to meet our first performance goal, applying a load that creates a displacement of the chassis strictly in the elastic torsional strain region. After reaching the max applied load for each run, the load was removed and the chassis was brought back to the original neutral position to check that there was no plastic deformation. For the second performance goal we were able assemble and disassemble the device each in under 15 minutes. Through performing the torsional stiffness test four times, we determined that the test was replicable with a minimal percent difference within 12%-difference. We accomplished the fourth performance goal by using dial indicators and a bottle jack modified with a pressure gauge. Although we did not test our device with multiple FSAE frames, we know that it will be able to accommodate different geometries due to the individual support system of our device. Also, the bolt patterns on the hub of each of the FSAE frame iterations are the same, as they use the same hubs and wheels every year. We were unable to achieve our final performance goal of getting an experimental value of the torsional stiffness is within 10% error compared to the FEA and hand calculations. In hindsight, as ideal as a 10%-error is, this was fairly unrealistic. In comparison to one of the top college FSAE teams in the nation, Cornell University, they have reported a best of 30%-error between the experimental results and theory. To improve on our performance and get closer to our goal, we could have invested in more sensitive displacement measuring tools with a larger tolerance. Also, we could have gotten a more direct and accurate measurement of the torque applied to the frame by using force transducers. Overall, our device met majority of our performance goals and was able to perform its most intrinsic function, measuring the torsional stiffness of the chassis. This functionality will help the WashU FSAE to optimize their chassis design, as well as providing them with more experimental data to back their design decisions with.

#### 7.2.2 Working Prototype – Video Link

<https://youtu.be/DccfEUI8NXg>

7.2.3 Working Prototype – Additional Photos



**Figure 25 – Dial indicator with extension rod attached**



**Figure 26 – Rear support set in concrete to fix the rear hubs of the chassis**



**Figure 27 – Modified bottle jack with pressure gauge to measure the applied force to the chassis**



**Figure 28 – Bottle jack attachment for front support**



Figure 29 – Fully assembled torsional stiffness measuring device on the 2015 FSAE chassis

### 7.3 FINAL PRESENTATION – VIDEO LINK

<https://www.youtube.com/watch?v=8VCbALABtpI&t=15s&list=WL&index=1>

## 8 DISCUSSION

### 8.1 DESIGN FOR MANUFACTURING – PART REDESIGN FOR INJECTION MOLDING

#### 8.1.1 Draft Analysis Results

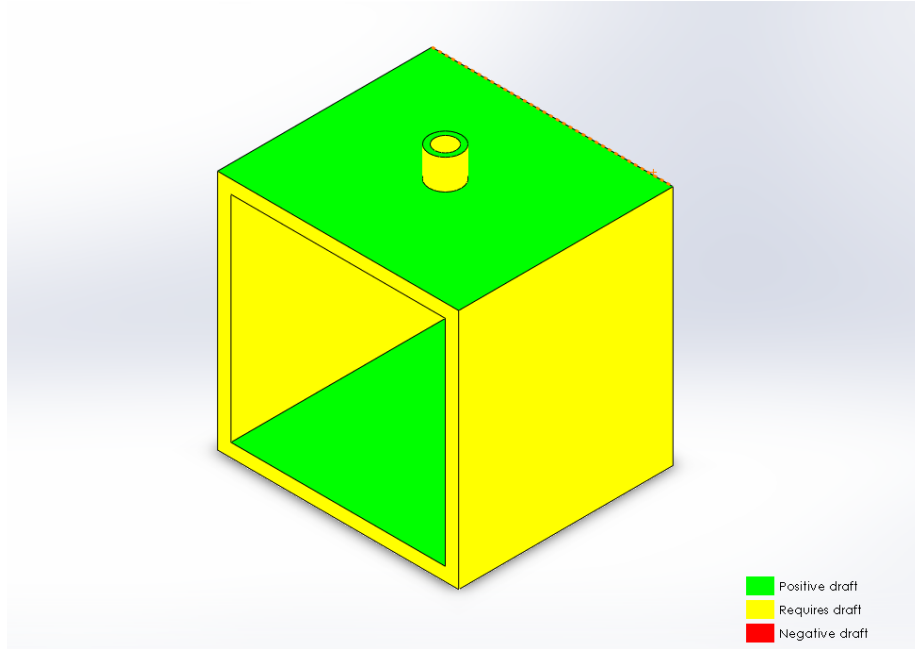

Figure 30 – Original CAD model of the dial indicator holder designed for PLA printing

(a)

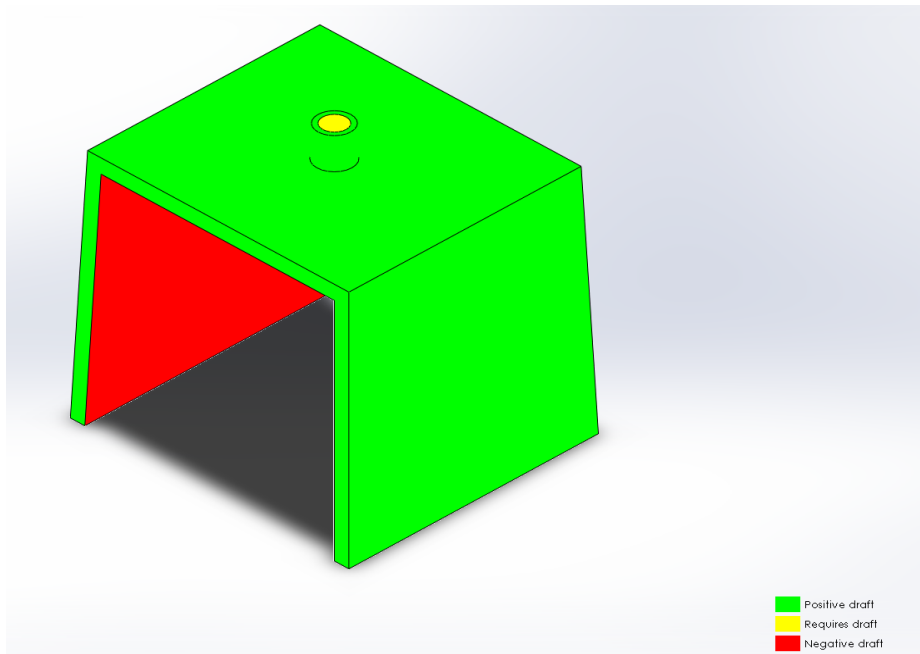

Figure 31 – Redesigned dial indicator holder to account for draft in injection mold printing



(b)

### 8.1.2 Explanation of Design Changes

In SolidWorks I used the “Draft” tool found in the “Features” tab. I specified the top face of the indicator holder as the neutral plane and set the draft angle to be 2 *deg*. This angled the faces of our part so that it would be easier to pull out of the mold in the direction we specified. The draft analysis shown in the above figures is in reference to a pull from the neutral plane in the positive y-direction.

## 8.2 DESIGN FOR USABILITY – EFFECT OF IMPAIRMENTS ON USABILITY

### 8.2.1 Vision

Someone with a vision impairment (e.g. presbyopia) might have difficulty reading the digital readout of the dial indicator. To improve the usability for vision-impaired individuals, we could include a magnifying glass to assist the user in reading the dial indicator.

### 8.2.2 Hearing

Someone with a hearing impairment might be unable to hear signs of failure or imminent failure somewhere in the frame. Consequently, they might proceed through despite the risk of failure and irreparably damage the frame. To improve the usability for hearing-impaired individuals, we could modify our design by connecting an air horn the dial indicator through some Arduino. When the readout in a sensitive area exceeded some critical value, the Arduino would activate the air horn. The user would then be warned of the risk.

### 8.2.3 Physical

Someone with a physical impairment (e.g. arthritis of muscle weakness) might have difficulty raising the piston of the bottle jack with the pump, raising the scissor jacks, using the G-clamps, or screwing on the nuts to the hub. To improve the usability for physically impaired individuals, we could modify our design by connecting the scissor jacks to motors, connecting the bottle jack pump to a crank rod and a motor, and substituting the G-clamps with an alternative, more easily operated clamping device.

### 8.2.4 Language

Someone with a language impairment might have difficulty reading the units on digital readout of the dial indicator and the button description of the dial indicator. To assist these individuals in the use of our product, we could provide translations on or near the dial indicator.

## 8.2 OVERALL EXPERIENCE

### 8.2.1 Does your final project result align with the initial project description?

Although our initial project description was not very thorough, our final project result still aligns with it. We made a device that twist particular parts of the frame and produces numbers required to calculate the torsional stiffness of the frame.

### 8.2.2 Was the project more or less difficult than you had expected?

Our group had minimal design project experience before beginning this project. As a result, our expectations initially were, to some extent, ambitious. There were a few mistakes and underestimations in our initial design of the device, cost estimation and parts we planned on purchasing. These brought a few

challenges throughout the project. However, by making modifications to our designs and optimizing on our resources, we were able to achieve a realistic goal by the end of the project.

#### 8.2.3 In what ways do you wish your final prototype would have performed better?

Our final prototype is more or less within the scope of our expectations. Our results from measurements for dial indicators and pressure gauges were reliable and replicable. Hypothetically, if there was more time and budget, we would make our device sophisticated by using measuring tools of higher precision. However, we did not produce values of torsional stiffness within the range of 10% difference from FEA expectations. We would have liked to be more successful in this regard.

#### 8.2.4 Was your group missing any critical information when you evaluated concepts?

When evaluating concepts, we had researched the project material sufficiently to present and compare many feasible concepts.

#### 8.2.5 Were there additional engineering analyses that could have helped guide your design?

Our engineering analysis involved theoretical calculations of load and moment distributions throughout chassis and SOLIDWORKS FEA results. We believe that our FEA results were optimal and useful to make comparisons with our experimental results. However, due to excess unknowns, there were limitations on our theoretical engineering analysis. Also, we may have developed a better calibration equation for the pressure gauge had we been able to test more weights. This would improve the accuracy of our results. Due to limited resources, we were unable to exceed about 15 pounds.

#### 8.2.6 How did you identify your most relevant codes and standards and how they influence revision of the design?

We asked Lauren Todd to research some applicable standards for our project. She directed us towards the SAE standards website where we were able to sort through hundreds of standards and find one relevant to our project. The standard we chose did not influence design revisions because it pertained strictly to welding processes, not on constraints for our product.

#### 8.2.7 What ethical considerations (from the Engineering Ethics and Design for Environment seminar) are relevant to your device? How could these considerations be addressed?

The afterlife of our prototype must be considered within the scope of engineering ethics. The prototype does not produce any harmful byproducts, but the disposal of some of the equipment could be hazardous for the environment. The electronic dial indicators, for example, would have to be disposed of thoughtfully in order to avoid pollution.

#### 8.2.8 On which part(s) of the design process should your group have spent more time? Which parts required less time?

Our group should have spent more time in the design process considering the space that the frame would fill and how this space would interact with our prototype. All of our time was devoted towards understanding the project and progressing in some way. Therefore, we would not reduce the time spent on any particular design activity.

### 8.2.9 Was there a task on your Gantt chart that was much harder than expected? Were there any that were much easier?

The manufacturing portion, in general, took far longer than expected. Also, the calculations and engineering analysis was more difficult than expected. The Solidworks files did not cooperate as expected, so that process required a considerable amount of troubleshooting.

### 8.2.10 Was there a component of your prototype that was significantly easier or harder to make/assemble than you expected?

The bottle jack modification to a pressure reading jack was the part that we expected to be of a significant challenge. Fortunately, disassembling/assembling and machining of the bottle jack went fairly smooth. As for the rear anchoring parts, they were challenging in assembly and probably took the most time since the concrete involved required 24 hours to set.

### 8.2.11 If your budget were increased to 10x its original amount, would your approach have changed? If so, in what specific ways?

Because of budget limitations, we were not able to purchase a few parts that we initially planned to. One of this is a weighing scale. We planned on purchasing a weighing scale to measure load applied at certain locations (rear and front), however, these parts were expensive beyond our budget. So, if budget was increase 10X, we would use the scales for more precise load measurements. Alternatively, we could have afforded load cells to measure load applied closer to the location of the application of load. We would also be able to afford stock metals and would therefore have to think more carefully about the geometry of our design and how it would interact with the frame. Realistically, we were constrained to stock material of a particular length that barely sufficed.

### 8.2.12 If you were able to take the course again with the same project and group, what would you have done differently the second time around?

If we could repeat the project, we would have made more realistic and professional plans at the beginning of the project. We did not experience any significant negative impact due to this aspect since we modified and reexamined our project plan throughout the semester, but, in regards to time, having a more insightful process plan would benefit in completing the project with minimal challenge.

### 8.2.13 Were your team member's skills complementary?

Yes, our respective skills played a significant role in cooperating to accomplish the project. Starting from preparing a design plan to completing this report, there were different skill sets contributed from each group member. These skills range widely: making simple design sketches, effectively using the SOLIDWORKS for FEA, manufacturing parts, technical writing, organizing etc.

### 8.2.14 Was any needed skill missing from the group?

None of us had any welding experience, and one of our parts, the front support, required to T joint welds. Thus, the race team helped to weld the part. Additionally, more manufacturing experience would have hastened manufacturing processes.

### 8.2.15 Has the project enhanced your design skills?

This project has taught many valuable lessons regarding the design process. We developed an understanding for the depth of consideration required when designing a product. Gaining experience in the design process has provided us with insight into potential errors, setbacks, and challenges involved.

We are confident that we would be able to perform more efficiently and effectively when repeating the process in the future.

#### 8.2.16 Would you now feel more comfortable accepting a design project assignment at a job?

Now that we are more familiar with necessary design processes, accepting a new project would be much easier. Although things such as the type of design project and time constraint may differ, we have now acquired the necessary skills to devise a realistic design plan, and we have the technical skills to accomplish a project.

#### 8.2.17 Are there projects you would attempt now that you would not have attempted before?

With our newly acquired design experience on a FSAE racing-related project, we now feel more comfortable attempting projects involved in the design of the car, particularly the chassis.

### 9 APPENDIX A - PARTS LIST

Table 5 – Cost accounting workbook of theoretical expenditures

	Part	Source Link	Supplier Part Number	Color, TPI, other part IDs	Unit price	Tax (\$0.00 if tax exemption applied)	Shipping	Quantity	Total price
1	Displacement Gauges	<a href="#">Amazon</a>	NTK020	Grey	\$23.95	\$0.00	\$0.00	4	\$95.80
2	Bottle Jack	<a href="#">Amazon</a>	T90203B	Red	\$12.21	\$0.00	\$6.95	2	\$24.42
3	1/4" Black Elbow	<a href="#">Home Depot</a>	520-301HN	Black	\$2.84	\$0.24	\$0.00	2	\$5.92
4	1" x 3" x 12" maple	<a href="#">Home Depot</a>	165360	Maple Board	\$2.07	\$1.05	\$0.00	12	\$25.89
5	Pressure Gauge	<a href="#">McMaster-Carr</a>	4089K61	Plastic Case	\$9.95	\$0.00	\$0.00	2	\$19.90
6	Steel Tubing	<a href="#">McMaster-Carr</a>	89975K341	Straight	\$23.90	\$0.00	\$0.00	1	\$23.90
7	1/4" Steel Plate	<a href="#">McMaster-Carr</a>	1388K104	1/4" Thick	\$16.70	\$0.00	\$0.00	1	\$16.70
8	1/2" Steel Plate	<a href="#">McMaster-Carr</a>	6544K37	1/2" Thick	\$94.31	\$0.00	\$0.00	1	\$94.31
9	80 lb Concrete	<a href="#">Low's</a>	10385	Quikrete	\$4.30	\$0.36	\$0.00	2	\$8.60
10	Scissor Jack	<a href="#">Northern Tool</a>	46212	1-Ton	\$14.99	\$2.53	\$6.95	4	\$59.96
11	PLA Filament	<a href="#">Hobby King</a>	741000018-0	Red	\$12.51	\$0.53	\$6.95	1	\$12.51
12	Aluminum Tubing	<a href="#">McMaster-Carr</a>	9056K61	Straight	\$5.61	\$0.00	\$0.00	4	\$22.44
<b>Total:</b>									<b>\$410.35</b>

### 10 APPENDIX B - CAD MODELS

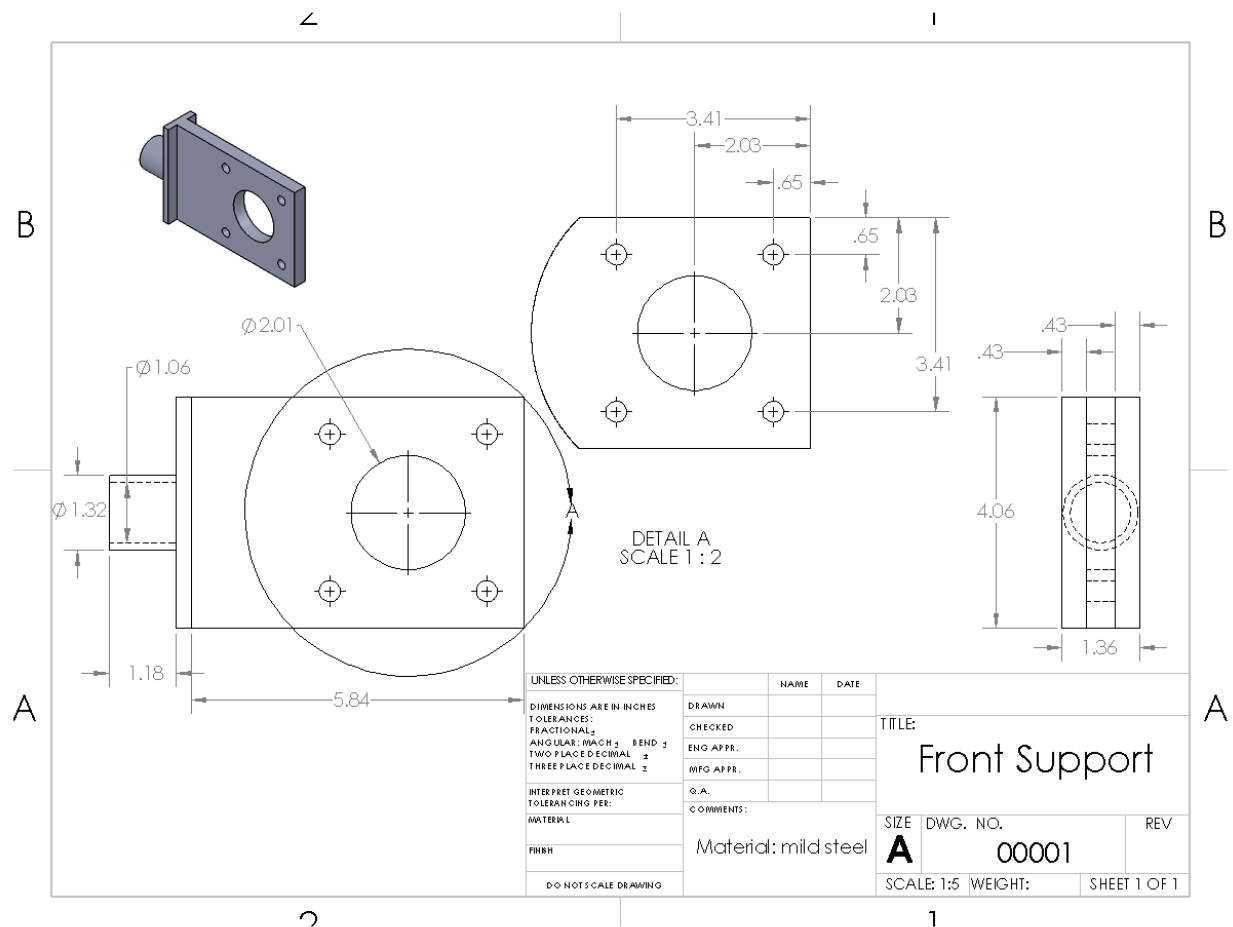

Figure 32 – Part drawing of front support to be manufactured with horizontal saw and vertical mill

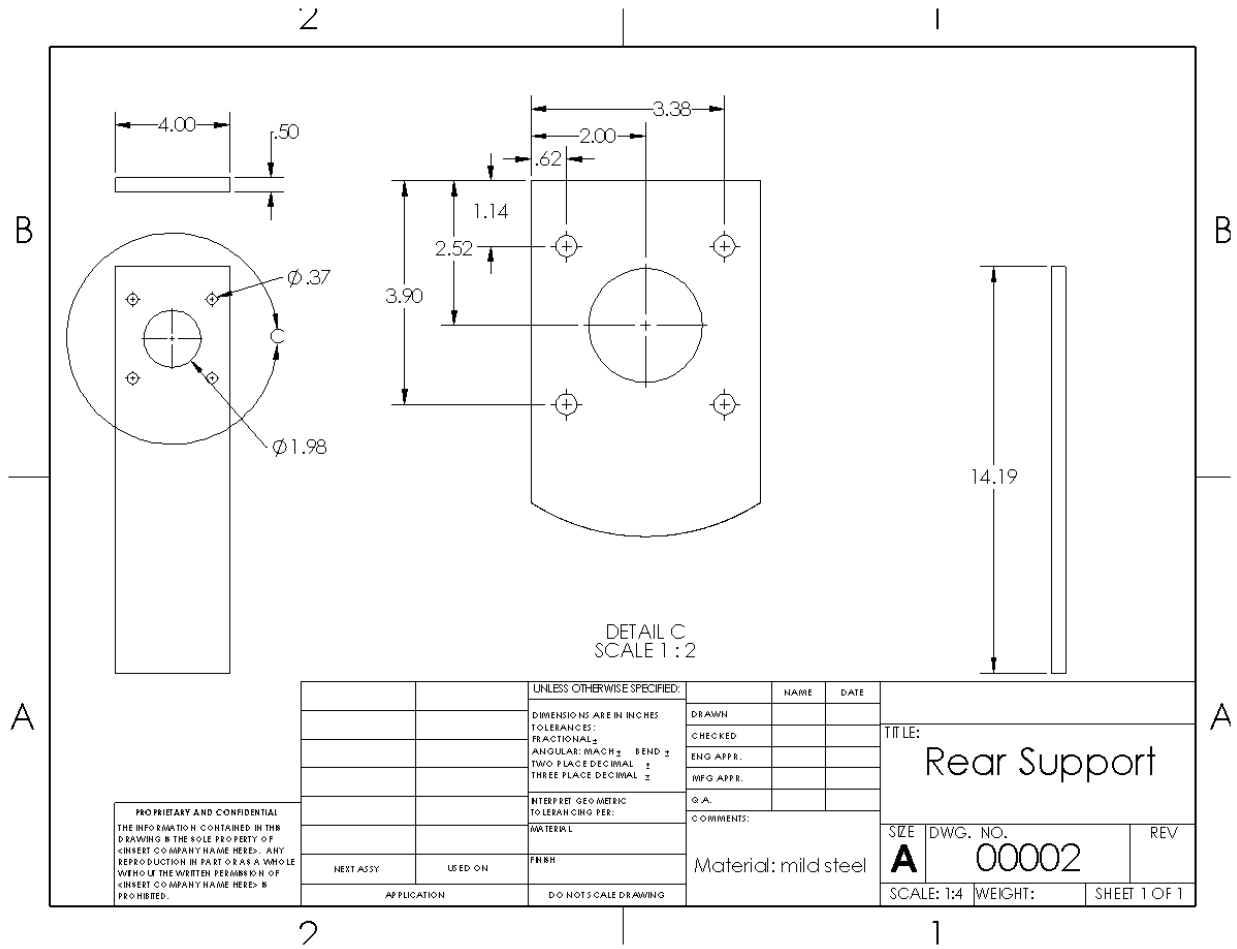

Figure 33 – Part drawing of rear support to be manufactured using vertical mill

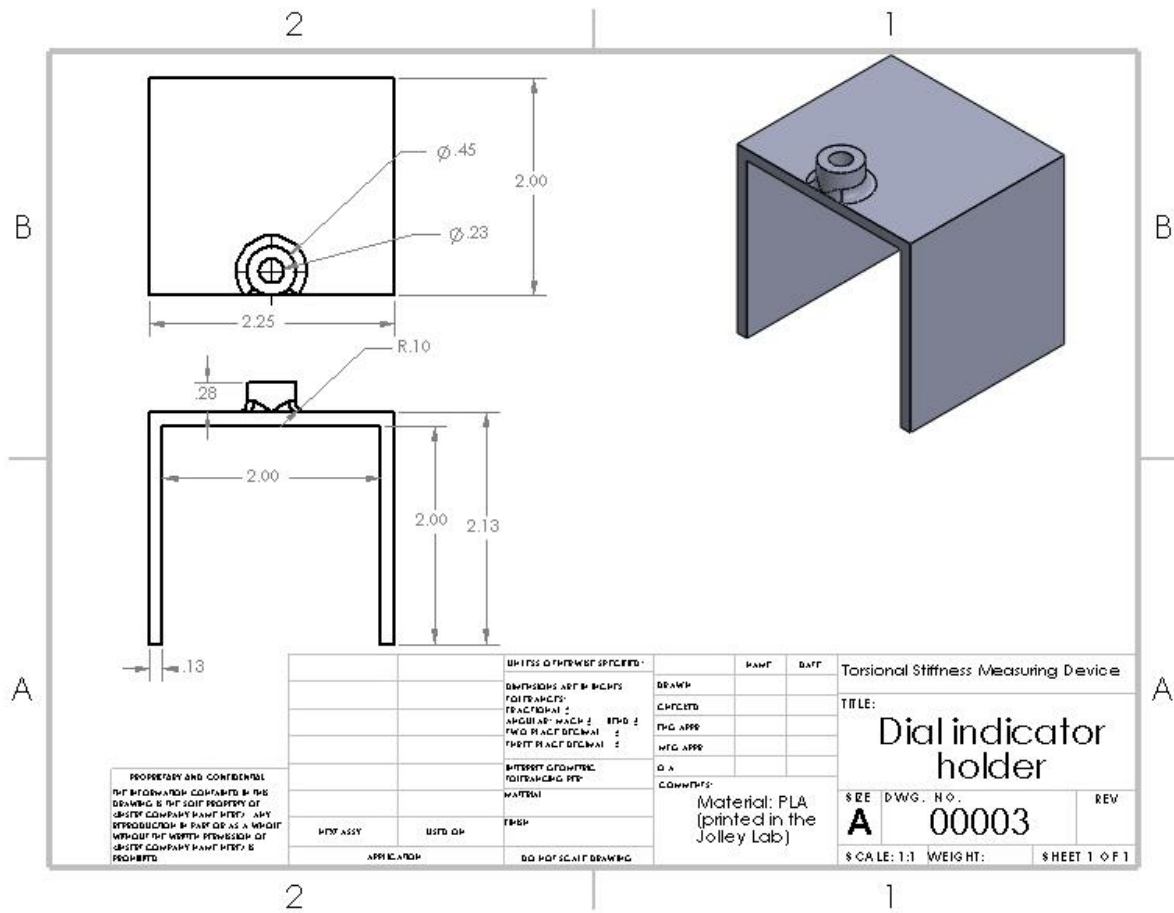

Figure 34 – Part drawing of dial indicator holder to be manufactured using FDM

