

Washington University in St. Louis

## Washington University Open Scholarship

---

Mechanical Engineering Design Project Class

Mechanical Engineering & Materials Science

---

Fall 2018

### ARLISS Competition Canister Vehicle

Jessie Goldberg

*Washington University in St. Louis*

Nicholas Cornejo

*Washington University in St. Louis*

Tyler Smith

*Washington University in St. Louis*

Rachel Kershner

*Washington University in St. Louis*

Follow this and additional works at: <https://openscholarship.wustl.edu/mems411>



Part of the [Mechanical Engineering Commons](#)

---

#### Recommended Citation

Goldberg, Jessie; Cornejo, Nicholas; Smith, Tyler; and Kershner, Rachel, "ARLISS Competition Canister Vehicle" (2018). *Mechanical Engineering Design Project Class*. 108.

<https://openscholarship.wustl.edu/mems411/108>

This Final Report is brought to you for free and open access by the Mechanical Engineering & Materials Science at Washington University Open Scholarship. It has been accepted for inclusion in Mechanical Engineering Design Project Class by an authorized administrator of Washington University Open Scholarship. For more information, please contact [digital@wumail.wustl.edu](mailto:digital@wumail.wustl.edu).



# Washington University in St. Louis

---

## SCHOOL OF ENGINEERING & APPLIED SCIENCE

### *Executive Summary*

For our project, we designed a cannister vehicle that fits the design specifications of the ARLISS competition. For the ARLISS competition, the vehicles are loaded into a rocket, launched approximately 10,000 feet into the air, released, and then must autonomously navigate to a predetermined target on the ground. Because of our time restraint, we are focused on designing a vehicle of the correct dimensions (a maximum mass of 1050g, a maximum diameter of 146mm, and a maximum height of 240mm) that can simply travel on the ground over multiple types of terrain. Additionally, we designed a parachute release mechanism so that the vehicle would be able to land safely on the ground after falling from thousands of feet in the air. We began by conducting research for product design by analyzing existing product concepts as well as conducting an interview with the customer, Dr. Potter. After analyzing the user needs, we generated four different potential concept designs and evaluated them based on our selected criterion. Upon choosing a concept, we applied various engineering relationships and arrived at the concept embodiment. We then developed three performance goals before working on our prototype. Our goals were: the vehicle can withstand a 1 meter drop on surface of the turf, the vehicle can travel one mile without needing to recharge the battery, and the vehicle can travel at 3 mph. Our final prototype met all three of these performance goals.

## **MEMS 411: MECHANICAL ENGINEERING DESIGN PROJECT FALL 2018**

### **Cannister Vehicle**

Rachel Kershner

Jessie Goldberg

Nick Cornejo

Tyler Smith

## TABLE OF CONTENTS

|   |    |
|---|----|
| List of Figures .....                         | 2  |
| List of Tables.....                           | 3  |
| 1 Introduction.....                           | 4  |
| 2 Problem Understanding .....                 | 5  |
| 2.1 Background Information Study.....         | 5  |
| 2.2 User Needs .....                          | 9  |
| 2.3 Design Metrics .....                      | 10 |
| 2.4 Project Management .....                  | 10 |
| 3 Concept Generation .....                    | 11 |
| 3.1 Mockup Prototype.....                     | 11 |
| 3.2 Functional Decomposition .....            | 12 |
| 3.3 Alternative Design Concepts .....         | 14 |
| 4 Concept Selection .....                     | 18 |
| 4.1 Selection Criteria .....                  | 18 |
| 4.2 Concept Evaluation.....                   | 19 |
| 4.3 Evaluation Results .....                  | 19 |
| 4.4 Engineering Models/Relationships .....    | 20 |
| 5 Concept Embodiment .....                    | 21 |
| 5.1 Initial Embodiment .....                  | 21 |
| 5.2 Proof-of-Concept .....                    | 24 |
| 6 Working Prototype.....                      | 27 |
| 6.1 Overview .....                            | 27 |
| 6.2 Demonstration Documentation .....         | 27 |
| 6.3 Experimental Results .....                | 30 |
| 7 Design Refinement .....                     | 31 |
| 7.1 FEM Stress/Deflection Analysis.....       | 31 |
| 7.2 Design for Safety .....                   | 34 |
| 7.3 Design for Manufacturing.....             | 36 |
| 7.4 Design for Usability.....                 | 38 |
| 8 Discussion.....                             | 39 |
| 8.1 Project Development and Evolution .....   | 39 |
| 8.2 Design Resources .....                    | 40 |
| 8.3 Team Organization.....                    | 42 |
| Appendix A – Cost Accounting Worksheet .....  | 44 |
| Appendix B – Final Design Documentation ..... | 45 |
| Bibliography .....                            | 50 |

## LIST OF FIGURES

|  |    |
|--|----|
| Figure 1: Sphero Product .....   | 5  |
| Figure 2: Trekkbot .....   | 6  |
| Figure 3: Mini Round Robot Chassis Kit .....                             | 6  |
| Figure 4: Rover Patent Pictures .....                                    | 7  |
| Figure 5: Parachute Patent .....   | 8  |
| Figure 6: Gantt chart used to set and maintain project schedule .....    | 10 |
| Figure 7: Angle View .....   | 11 |
| Figure 8: Side View .....  | 11 |
| Figure 9: Front View.....  | 11 |
| Figure 10: Function Tree .....   | 12 |
| Figure 11: Morphological Chart .....                                     | 13 |
| Figure 12: Alternate Design Concept #1 (Tyler) .....                     | 14 |
| Figure 13: Alternate Design Concept #2 (Nick) .....                      | 15 |
| Figure 14: Alternate Design Concept #3 (Jessie) .....                    | 16 |
| Figure 15: Alternate Design Concept #4 (Rachel).....                     | 17 |
| Figure 16: Assembly View with BOM .....                                  | 21 |
| Figure 17: Exploded View .....   | 22 |
| Figure 18: Top/Side/Front Views w/Dimensions .....                       | 23 |
| Figure 19: Impulse Calculation.....                                      | 25 |
| Figure 20: Momentum Calculation.....                                     | 26 |
| Figure 21: Drag Force and Parachute Calculations .....                   | 26 |
| Figure 22: Front Isometric View .....                                    | 28 |
| Figure 23: Underside View.....   | 28 |
| Figure 24: Rear View.....  | 28 |
| Figure 25: Rear Isometric View.....                                      | 29 |
| Figure 26: Front View.....   | 29 |
| Figure 27: FEA Loading Scenario and Calculations .....                   | 31 |
| Figure 28: Unloaded model with mesh, loads and boundary conditions ..... | 32 |
| Figure 29: Von Mises stress plot .....                                   | 32 |
| Figure 30: Side-view of displacement plot.....                           | 33 |
| Figure 31: Isometric displacement plot .....                             | 33 |
| Figure 32: Risk assesment heat map.....                                  | 35 |
| Figure 33: Draft Analysis .....  | 36 |
| Figure 34: DFM Sheet Metal Analysis .....                                | 37 |
| Figure 35: DFM Mill and Drill Analysis .....                             | 37 |
| Figure 36: Working Prototype CAD Assembly.....                           | 45 |
| Figure 37: 3D Printed Tail Mount .....                                   | 46 |
| Figure 38: Custom Base Plate.....  | 47 |
| Figure 39: Custom Motor Bracket.....                                     | 48 |
| Figure 40: Stabilizing Tail .....  | 49 |

**LIST OF TABLES**

Table 2: Customer Needs Interview ..... 9

Table 3: Interpreted Customer Needs ..... 9

Table 4: Target Specifications ..... 10

Table 5: Analytic Hierarchy Process ..... 18

Table 6: Weighted Scoring Matrix ..... 19

Table 7: Proof of Concept Parts List ..... 24

# 1 INTRODUCTION

The ARLISS competition allows college students and faculty to build and test a prototype that is to be launched in the air thousands of feet and then must autonomously arrive at a predetermined GPS coordinate on the ground. The competition consists of two classes, the open class and the CanSat class. The difference between the two classes are the allowed sizes of the vehicles; the maximum allowed diameter, length, and mass of the CanSat class are smaller than those of the open class. For our design, we followed the dimensions for the open class. The open class allows a maximum diameter of 5.78 inches, a length of 10 inches, and a mass of 1800 grams. To win the ARLISS competition, a prototype must operate autonomously, stop within 10 meters of the target, and provide proof of controlled guidance to the target. Because of the time restraint of this course, we never intended to design a vehicle that could drive autonomously. We set out to design a vehicle that could survive a fall from thousands of feet, drive over various types of terrain, and fit the dimensions specified by the open class. We did not have plans of entering the competition, so our customer for this project was Dr. Potter.

## 2 PROBLEM UNDERSTANDING

### 2.1 BACKGROUND INFORMATION STUDY

To begin researching concepts for our product, we found three existing designs that are similar in size and usage as ours. These three existing designs are shown below.

1. Sphero Ball 2.0



**Figure 1: Sphero Product**

Link to product website: <https://www.sphero.com/sphero>

The Sphero Ball 2.0 is a robotic ball that is controlled by an app on a smartphone or tablet. The Sphero is waterproof, shock resistant, Bluetooth compatible, and can move at a speed up to 4 mph. The Sphero tablet and smartphone apps comes with various types of games that can be played with the Sphero. The Sphero comes with an inductive charging base that gives the product a battery life up to 60 minutes. Additionally, the product comes with 2 ramps that can be used to change the game play of the device. The Sphero can be controlled from a Bluetooth device up to a distance of 100 feet. Because of the success of the original Sphero ball, many variations have been created including the Sphero mini as well as Star Wars, Marvel, and Pixar themed versions of the Sphero. The Sphero Ball 2.0 has a diameter of 6 inches and weighs 1 lb.

## 2. Trekbot Micro Robotic Racer



**Figure 2: Trekbot**

Link to product information: <http://www.coolest-gadgets.com/20101010/trekbot-micro-robotic-racer/>

The Trekbot is a hubless robotic racer that comes with a 5-function USB controller. The remote controller enables to Trekbot to perform sharp turns, headstands, and full flips at its given speed. The Trekbot includes a built in USB charger. The Trekbot is sold at \$19.99 compared to the Sphero (shown above) that sells at \$89.99. The Trekbot comes in black, white, gold, and clear. Because of the four-frequency system working in the Trekbot, up to four uses can use the product to race simultaneously. The angled wheel design is optimal for performing spins and flips. Thirty minutes of charging allows the product to function for fifteen minutes.

## 3. Mini Round Robot Chassis Kit-2WD with DC Motors



**Figure 3: Mini Round Robot Chassis Kit**



Link to product website: <https://www.adafruit.com/product/3216>

Unlike the other two existing product concepts, this product comes as a kit that allows the customer to build the rover from start to finish. The kit comes with everything that the customer needs to build the shell of the two-wheel-drive robot. The kit comes with the metal plates that make up the chassis, two DC drive rotors with accompanying wheels, and a caster ball for balance. The customer adds a power supply, microcontroller board, and motor controller. The rover can undergo a near zero turning radius. The body and speed motors is appropriately designed for flat indoor surfaces. The Mini Round Robot Chassis Kit is sold for \$19.95.

### Related Patents

1. Rover, Patent No. US13349528

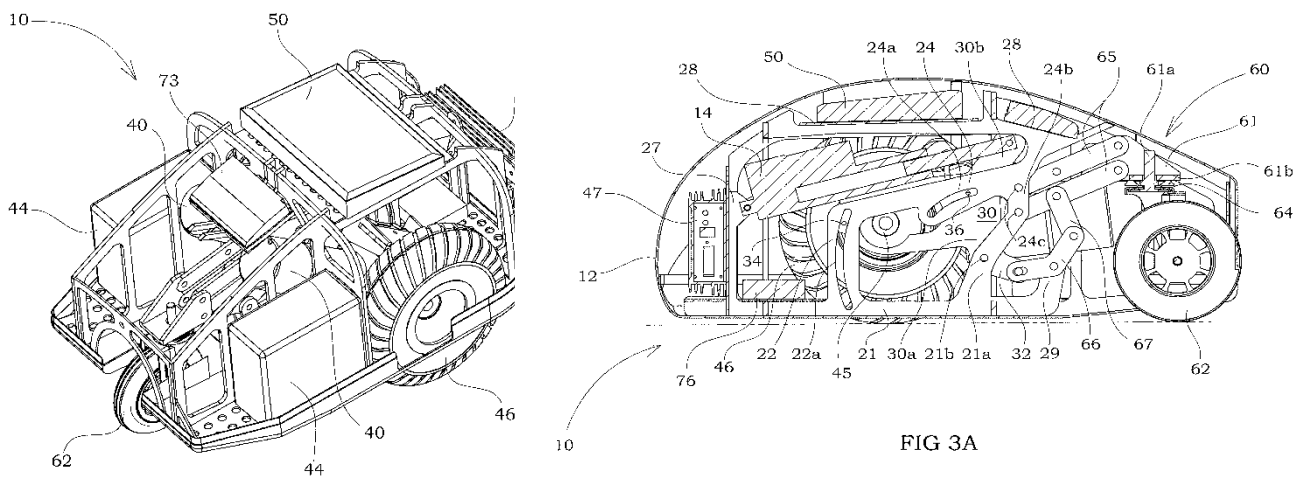

Figure 4: Rover Patent Pictures

Description: A rover comprised of a frame, a mounted motor, at least one driven wheel, a pivotally attached yoke, a sensor wheel, a sensor and a GPS receiver. Its purpose is to precisely determine the topography of a land parcel by contacting the parcel itself and logging data through a GPS sensor.

## 2. Parachute deployment patent, No. US15503089

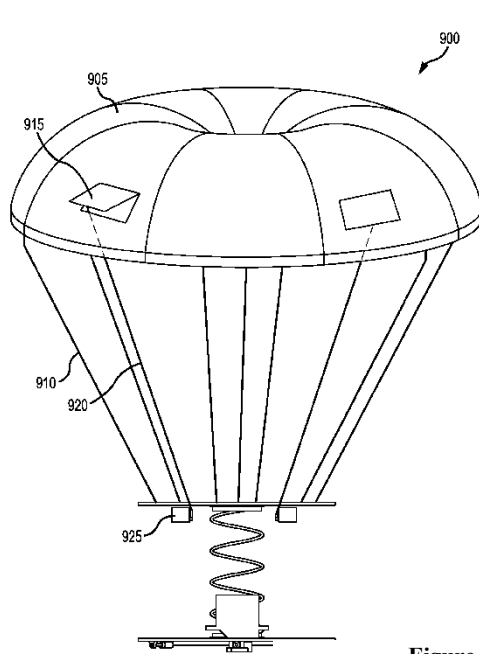

Figure 5: Parachute Patent

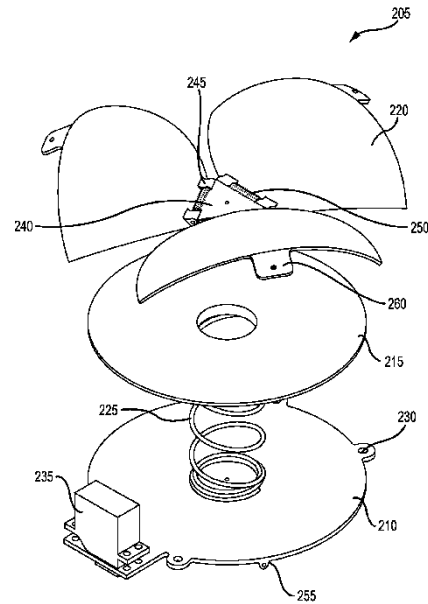

FIG. 2A

Description: A parachute deployment system for a small unmanned aerial vehicle. Comprised of a base attached to the vehicle, a deployment tray, an acceleration mechanism for deploying the tray, a cover, and a parachute. It also has a triggering mechanism which, once released, deploys the parachute in a rapid manner away from the vehicle.

Standards:

### ISO 18646-1:2016

ISO 18646-1:2016 is a standard that aims to facilitate understanding of performance of wheeled robots between users and manufacturers. It defines important characteristics of locomotion for wheeled robots and recommends how to test them. This standard could shape our design because it is important to test the characteristics of the canister vehicle in a consistent manner that yields clear results.

### ISO 9001:2015

ISO 9001:2015 specifies requirements for a quality management system that allows an organization to demonstrate its ability to consistently meet customer and statutory and regulatory requirements. It aims to increase customer satisfaction through the implementation of the system. This could affect our design process by ensuring that all customer requirements and objectives are met in a systematic way. While this code would not directly affect specifications in the design of the canister vehicle, it would affect the methods used to design the canister vehicle. Using different methods could yield different outcomes.

## 2.2 USER NEEDS

Table 1: Customer Needs Interview

| <p><b>Product:</b> CanSat Vehicle (CSV)<br/> <b>Customer:</b> Dr. James Jackson Potter</p> <p><b>Notes:</b> We interviewed Dr. Potter and were showed past designs, some more successful than others.</p> <p><b>Address:</b> Urbauer 310, Washington University Danforth Campus<br/> <b>Date:</b> September 7, 2018</p> |   |  |      |
|---|---|--|------|
| Question  | Customer Statement  | Interpreted Need   | Imp. |
| Pros (of current designs)   | Two wheels, various components located between wheels                           | CSV can move over terrain easily   | 5    |
|   | Stabilizing arm protruding from one wheel                                       | CSV is self-righting against acceleration forces                                   | 4    |
| Issues (of current designs)   | CSV flies to high altitude, cold ambient temps freeze components                | CSV has components designed to work at extreme atmospheric conditions              | 4    |
|   | Forces with parachute deployment are large, components can break                | Chute mechanism is engineered to survive deployment impact                         | 5    |
| Typical Uses  | Gets from point A to B, either autonomously or with prescribed movement program | CSV is easy to program and reprogram for different courses                         | 3    |
| Size of CSV   | CSV for this project will be open class   | CSV must fit into cannister no larger than 146 mm in diameter and 240 mm in height | 4    |
|   |   | CSV must not weight more than 1050g  | 5    |

Table 2: Interpreted Customer Needs

| Need Number | Need   | Importance |
|-------------|--|------------|
| 1           | CSV can mover over terrain easily                          | 5          |
| 2           | CSV is self-righting against acceleration forces           | 4          |
| 3           | CSV has temperature-design components                      | 4          |
| 4           | CSV has chute designed to withstand impact forces          | 5          |
| 5           | CSV is easy to program and re-program                      | 3          |
| 6           | CSV fits into prescribed cannister size (open class specs) | 4          |
| 7           | CSV does not weigh more than 1050g (open class specs)      | 5          |

## 2.3 DESIGN METRICS

Table 3: Target Specifications

| Metric Number | Associated Needs | Metric                                       | Units  | Acceptable | Ideal      |
|---------------|------------------|--|--------|------------|------------|
| 1             | 1                | Height of obstacle vehicle can navigate over | mm     | 25         | 100        |
| 2             | 1,3              | CSV is IP 51 Rated                           | binary | pass       | pass       |
| 3             | 2                | CSV can reorient when flipped over           | binary | pass       | pass       |
| 4             | 3                | Temperature operating range                  | °C     | 0-40       | (-20) - 50 |
| 5             | 4                | Parachute can withstand deployment forces    | binary | pass       | pass       |
| 6             | 5                | Multiple tests can be run                    | binary | pass       | pass       |
| 7             | 6                | Height, Diameter                             | mm     | 240, 146   | 230, 140   |
| 8             | 7                | Total weight                                 | g      | <1050      | 1000       |

## 2.4 PROJECT MANAGEMENT

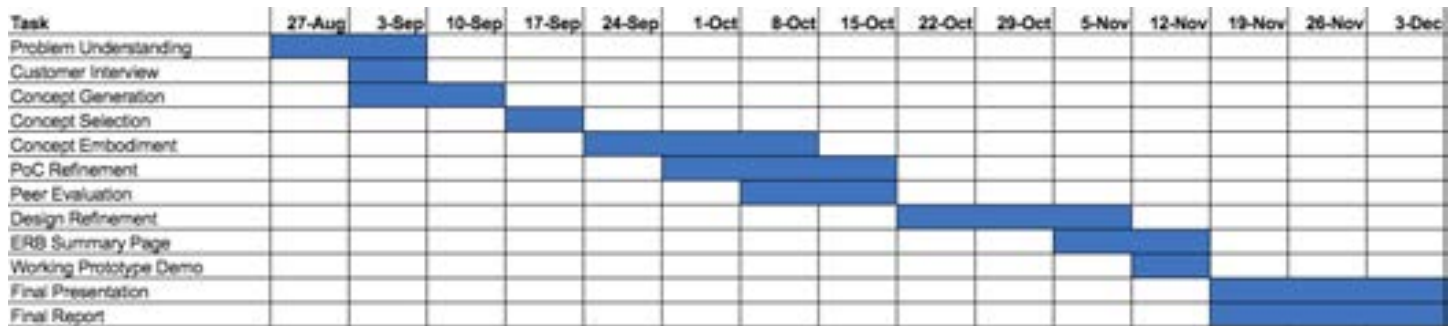

Figure 6: Gantt chart used to set and maintain project schedule

### 3 CONCEPT GENERATION

#### 3.1 MOCKUP PROTOTYPE



Figure 7: Angle View



Figure 8: Side View

#### Description:

Our initial concept was one where the wheels of our cannister vehicle were installed around the inner cylinder as displayed in the images above and to the right. We would then be able to seal the inner cylinder and have the motors and the rest of the components of the device would be completely enclosed. We learned from the mockup that this would be very difficult to accomplish as it would require complex parts. Further, we determined that we need a space for some type of tail to deploy after the vehicle has landed so that it can balance the torque of the motors and move forward. This will require a main capsule that is not completely sealed.



Figure 9: Front View

3.2 FUNCTIONAL DECOMPOSITION

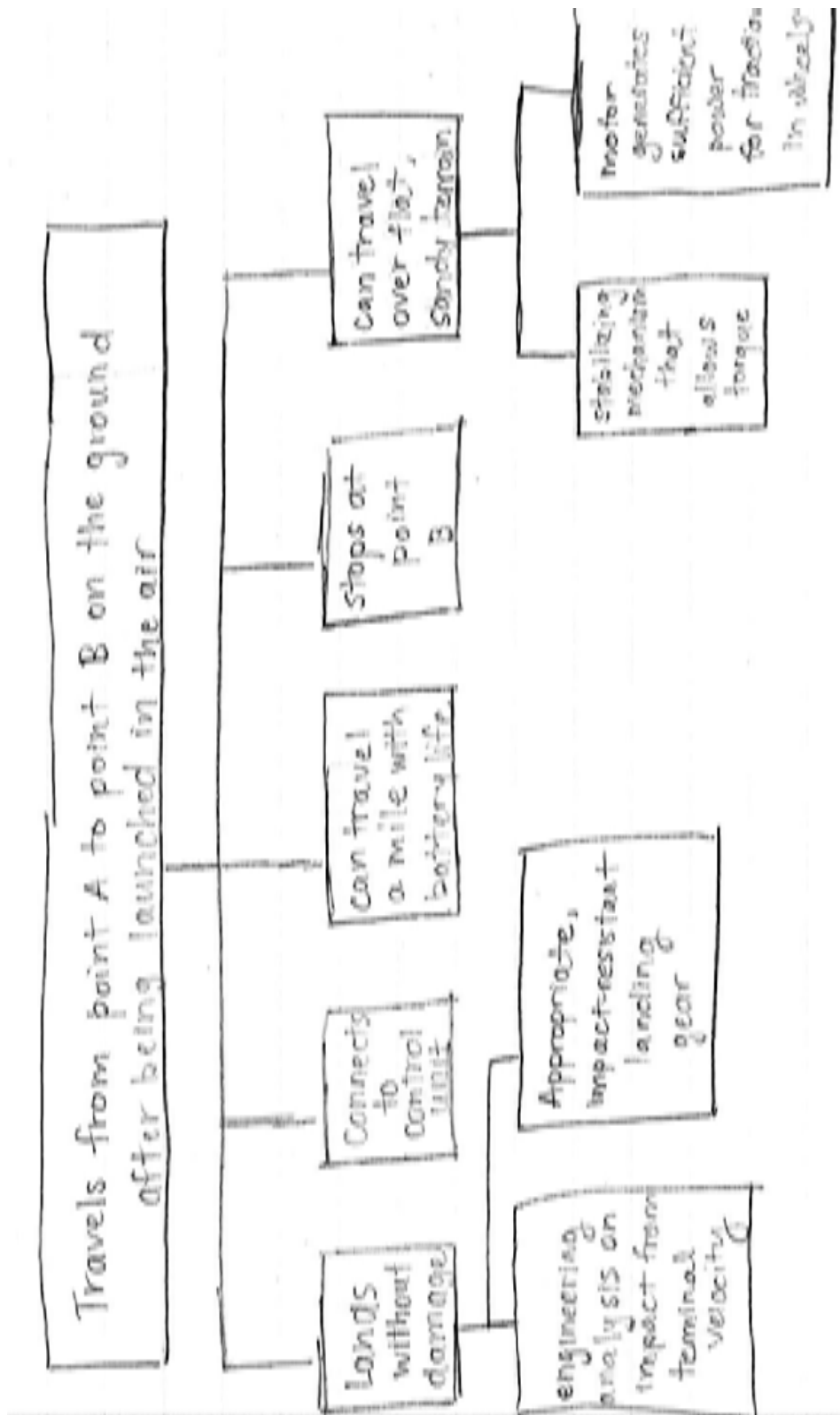

Figure 10: Function Tree

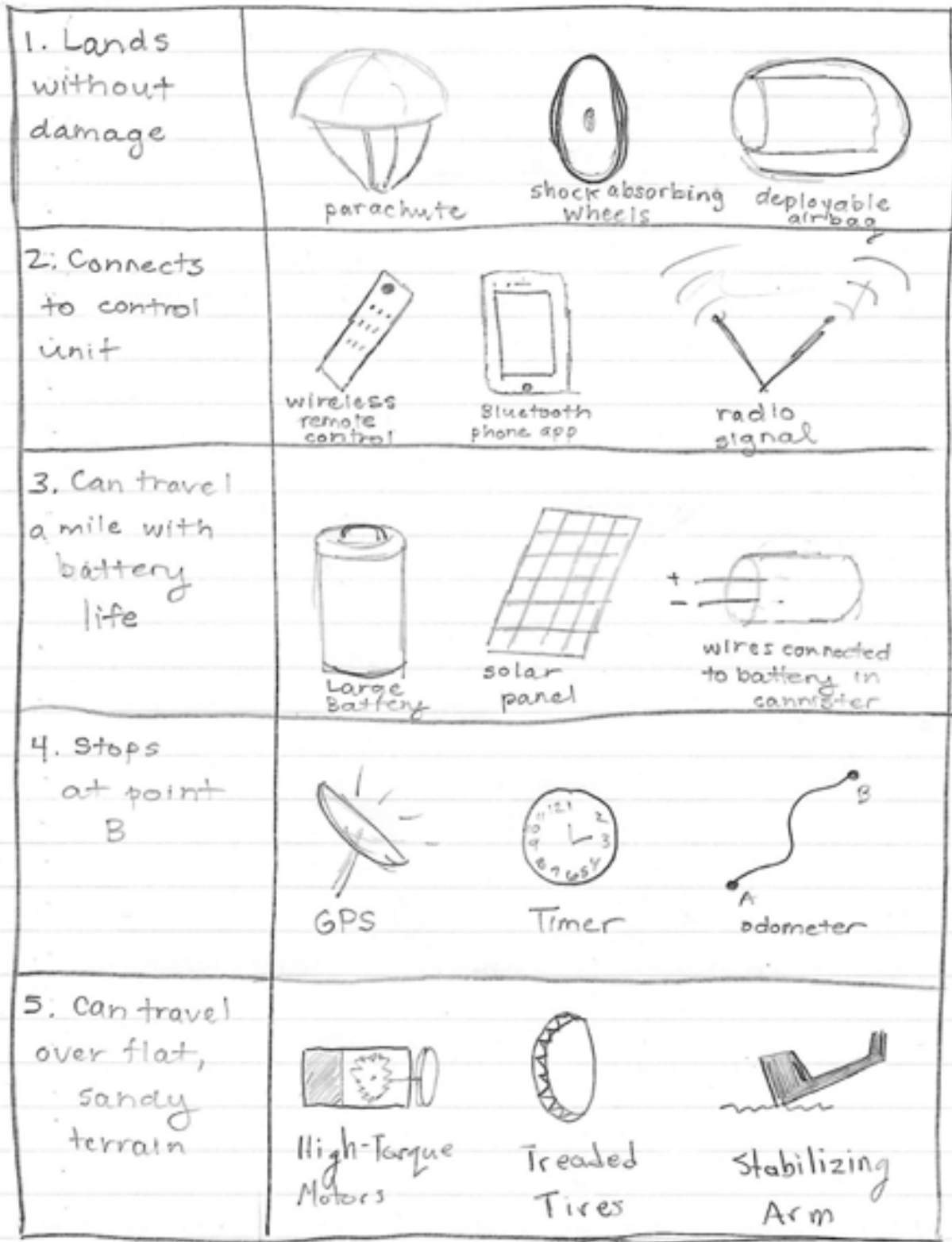

Figure 11: Morphological Chart

### 3.3 ALTERNATIVE DESIGN CONCEPTS

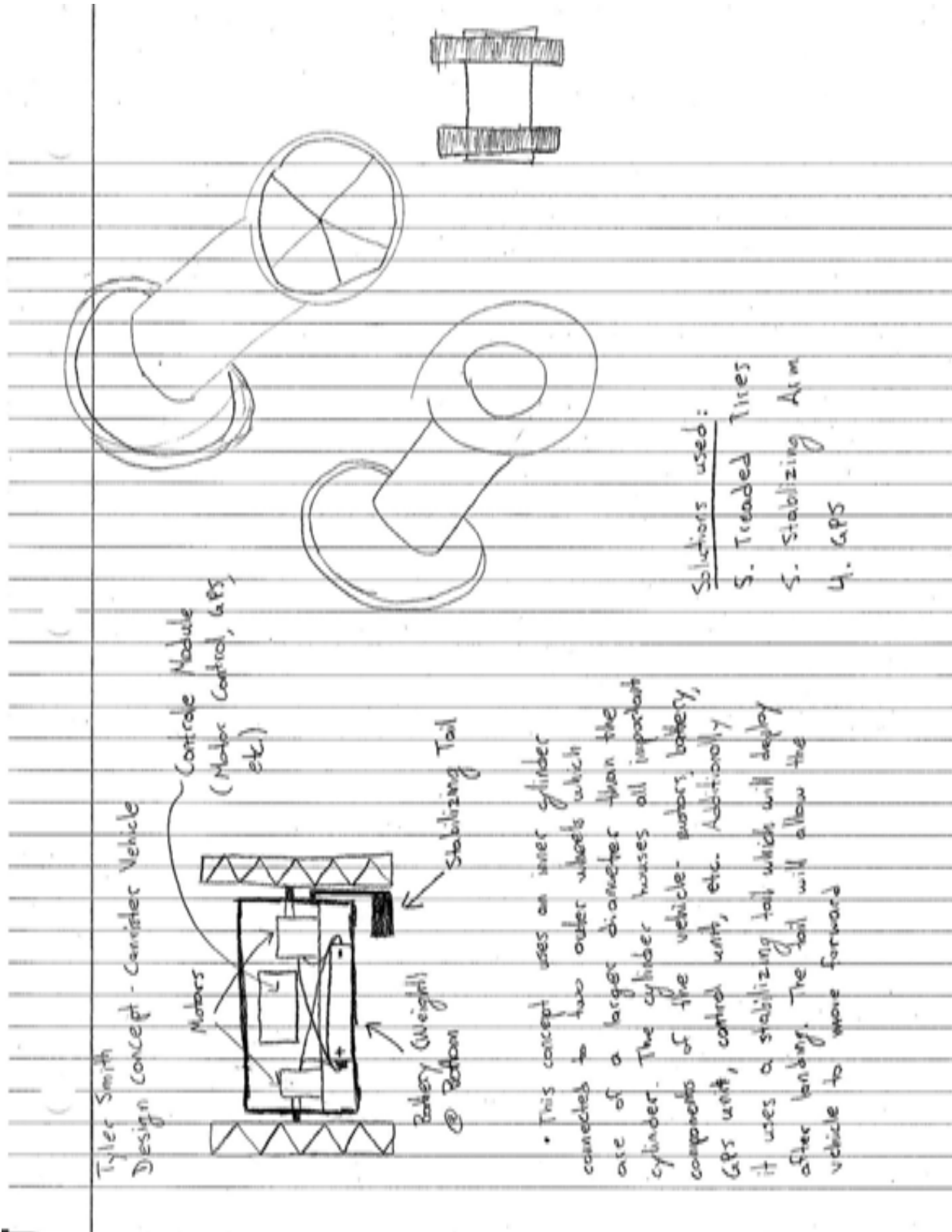
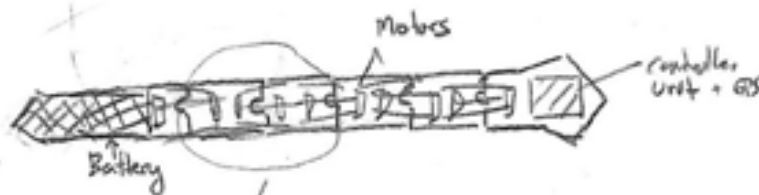
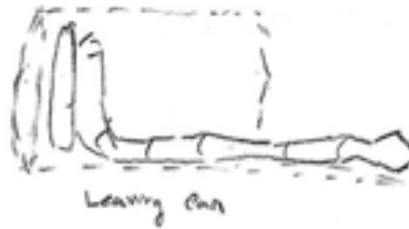

Figure 12: Alternate Design Concept #1 (Tyler)



Concept Name: "Snake Rover"

Group Member: Nick Cornejo



Solutions:

- 1) shock absorbing design
- 2) large battery
- 3) high torque motors
- 4) gps

Description: A microcontroller actuates a series of servo motors that rotate in the  $0^\circ$  and  $180^\circ$  plane, as well  $90^\circ$  and  $270^\circ$  plane in alternating sequence. To fit in the container, the Snake bot coils up. The battery is stored in the tail and the processors are located at the head.

Figure 13: Alternate Design Concept #2 (Nick)

Jessie Goldberg

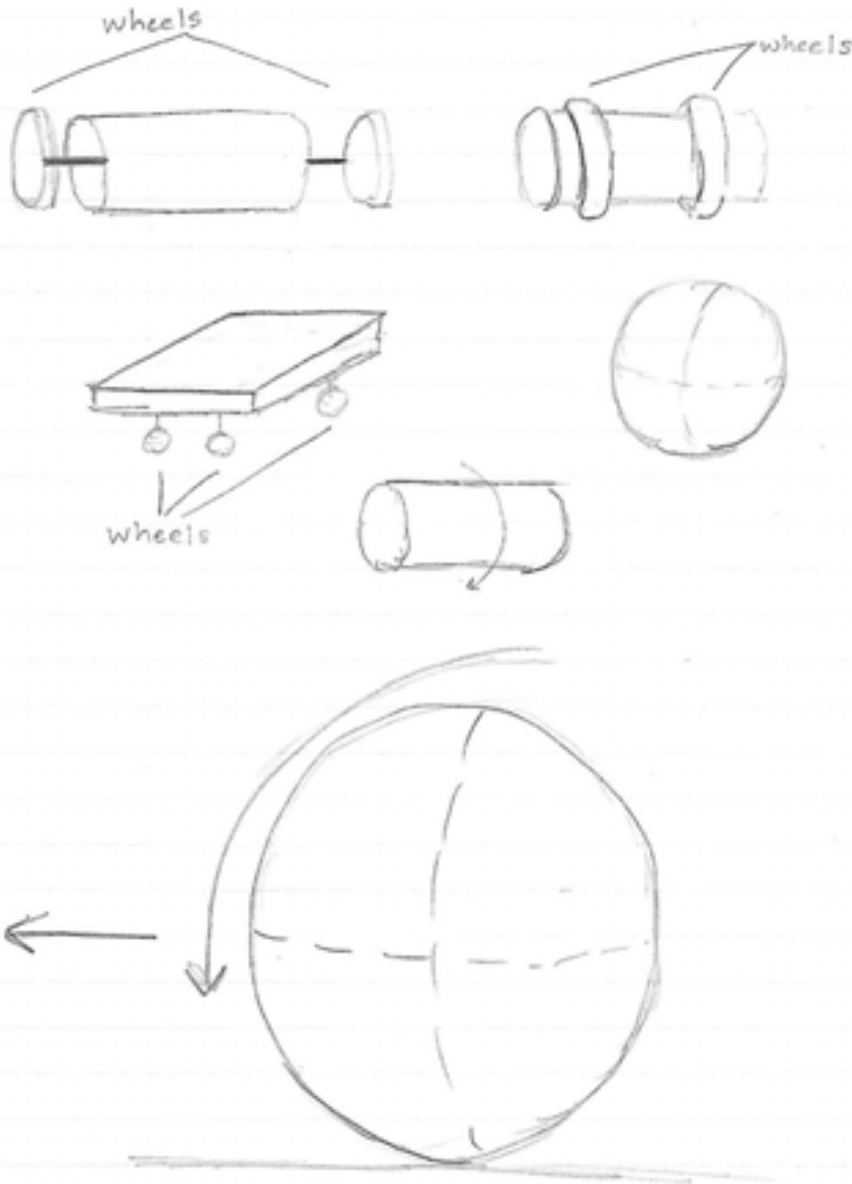

This design is based on the Sphero, which is an existing design we researched. This design would consist only of a sphere that functions as both the body and the "wheel", rotating around its center of gravity to move/propel itself forward. The morphological chart features this design has are: shock absorbing wheels, bluetooth phone app, solar panel charging, GPS, and high torque motors.

Figure 14: Alternate Design Concept #3 (Jessie)

Rachel: Kershner

### 4-Wheeled Design Concept

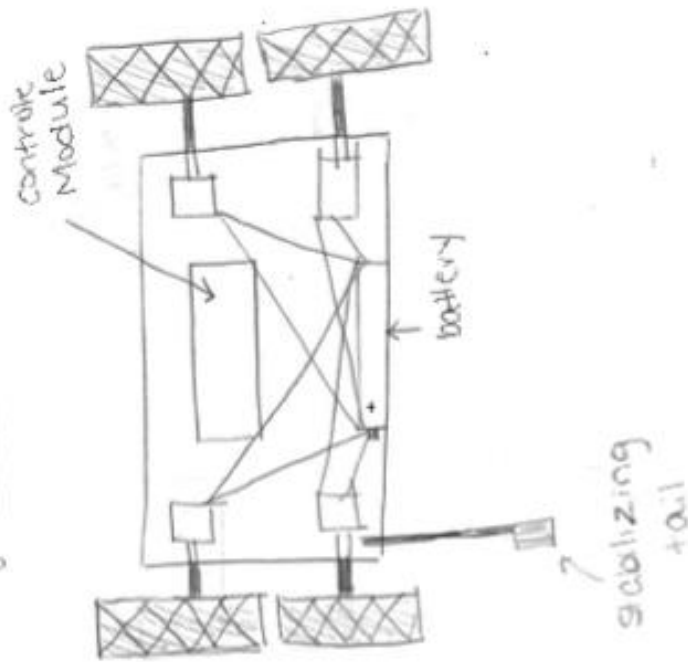

This concept has 4 wheels and resembles an ATV or base cart. The wheels are large and treaded. In the center console are the motor, battery, and control module. There is a stabilizing tail that keeps the cart's vehicle grounded.

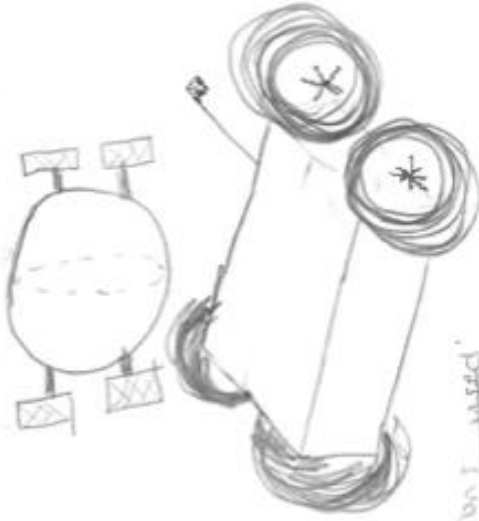

- Solution used:
- 5. stabilizing arm
  - 6. treaded tires
  - 4. GPS

Figure 15: Alternate Design Concept #4 (Rachel)

## 4 CONCEPT SELECTION



### 4.1 SELECTION CRITERIA

Table 4: Analytic Hierarchy Process

|   | Size: Open class specifications | Travels over sandy terrain | Self-righting against acceleration forces | Parachute designed to withstand impact | Designed for temperatures at altitude | Easy to Program/reprogram | Row Total    | Weight Value | Weight (%)  |
|---|---------------------------------|----------------------------|---|--|---------------------------------------|---------------------------|--------------|--------------|-------------|
| Size: Open class specifications           | 1.00                            | 5.00                       | 5.00                                      | 3.00                                   | 7.00                                  | 7.00                      | 28.00        | 0.35         | 35.34%      |
| Travels over sandy terrain                | 0.20                            | 1.00                       | 1.00                                      | 3.00                                   | 5.00                                  | 7.00                      | 17.20        | 0.22         | 21.71%      |
| Self-righting against acceleration forces | 0.20                            | 1.00                       | 1.00                                      | 5.00                                   | 7.00                                  | 5.00                      | 19.20        | 0.24         | 24.23%      |
| Parachute designed to withstand impact    | 0.33                            | 0.33                       | 0.20                                      | 1.00                                   | 3.00                                  | 3.00                      | 7.87         | 0.10         | 9.93%       |
| Designed for temperatures at altitude     | 0.14                            | 0.20                       | 0.14                                      | 0.33                                   | 1.00                                  | 0.33                      | 2.15         | 0.03         | 2.72%       |
| Easy to program/reprogram                 | 0.14                            | 0.14                       | 0.20                                      | 0.33                                   | 3.00                                  | 1.00                      | 4.82         | 0.06         | 6.08%       |
| <b>Column Total:</b>                      |                                 |                            |   |  |                                       |                           | <b>79.24</b> | <b>1.00</b>  | <b>100%</b> |

## 4.2 CONCEPT EVALUATION

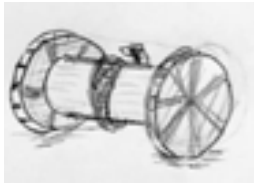
Table 5: Weighted Scoring Matrix

|                                     |            | Alternative Design Concepts   |          |   |          |  |          |   |          |
|-------------------------------------|------------|---|----------|---|----------|--|----------|---|----------|
|                                     |            | Box w/wheels  |          | Cylinder  |          | Sphere   |          | Snake   |          |
|                                     |            |  |          |  |          |  |          |  |          |
| Selection Criterion                 | Weight (%) | Rating  | Weighted | Rating  | Weighted | Rating   | Weighted | Rating  | Weighted |
| Size: Open class Specs              | 35.34      | 3   | 1.06     | 5   | 1.77     | 3  | 1.06     | 5   | 1.77     |
| Travels over sandy terrain          | 21.71      | 4   | 0.87     | 5   | 1.09     | 4  | 0.87     | 5   | 1.09     |
| Self-righting against accel. Forces | 24.23      | 5   | 1.21     | 5   | 1.21     | 5  | 1.21     | 4   | 0.97     |
| Parachute withstands impact         | 9.93       | 2   | 0.20     | 3   | 0.30     | 2  | 0.20     | 5   | 0.50     |
| Designed for temps at 10,000ft      | 2.72       | 3   | 0.08     | 3   | 0.08     | 1  | 0.03     | 2   | 0.05     |
| Easy to program/re program          | 6.08       | 3   | 0.18     | 1   | 0.06     | 4  | 0.24     | 1   | 0.06     |
| <b>Total score</b>                  |            | <b>3.603</b>  |          | <b>4.504</b>  |          | <b>3.609</b>   |          | <b>4.433</b>  |          |
| <b>Rank</b>                         |            | <b>4</b>  |          | <b>1</b>  |          | <b>3</b>   |          | <b>2</b>  |          |

## 4.3 EVALUATION RESULTS

Our weighted scoring matrix resulted in the cylinder design being the best for our project. This happened to be the design we embodied in our prototype and is the design we would like to proceed with. It scored the highest in our three most important criteria: its ability to fit within the size specifications, its ability to travel over sandy terrain, and its ability to right itself against motor acceleration forces. The design is shaped most like the cannister, which will naturally enable us to fit all the components into the launching container. Further, it has very large, treaded tires and a high ground clearance which will allow it to conquer rougher terrain. The spring-loaded tail with attached trailing wheel will provide a solid base against

which the motors can apply force to move the vehicle. We will have to further develop our ideas on how to make the cylinder design easier to program for specific missions.

#### 4.4 ENGINEERING MODELS/RELATIONSHIPS

##### 1. Impulse

$$\Delta p = F\Delta t = ma\Delta t$$

Where:  $\Delta p$  = change in momentum,  $F$  = force,  $\Delta t$  = change in time,  $m$  = mass,  $a$  = acceleration

- This is the equation for the impulse that is delivered to the vehicle. Specifically, we will use this to figure out the acceleration on the vehicle when the parachute is deployed. This will assist us greatly in determining the size of the components of the parachute (parachute size, chute cable size, connections, etc.)

##### 2. Moment

$$M(r) = Fr = \mu F_n r$$

Where:  $M(r)$  = moment,  $F$  = force,  $r$  = radius,  $\mu$  = coefficient of friction, and  $F_n$  = normal force.

- This equation calculates the moment applied to the ground by the wheels from the motors, as a function of the coefficient of friction between the wheels and ground. This will help us determine the composition of tire compound to use because it will help us determine the limits of how much force the wheels can apply before our self-righting mechanism fails.

##### 3. Drag Force

$$F_D = \frac{1}{2}\rho C_d A v^2$$

Where:  $F_D$  = drag force,  $\rho$  = density (of air),  $C_d$  = is drag coefficient,  $A$  = surface area,  $v$  = velocity

This equation will help us design our parachute. If we get an estimate of how much drag force we will need we will be able to pick our parachute material and size. It cannot be too big or heavy so that it does not fit into the cannister or go over our weight limit.

# 5 CONCEPT EMBODIMENT

## 5.1 INITIAL EMBODIMENT

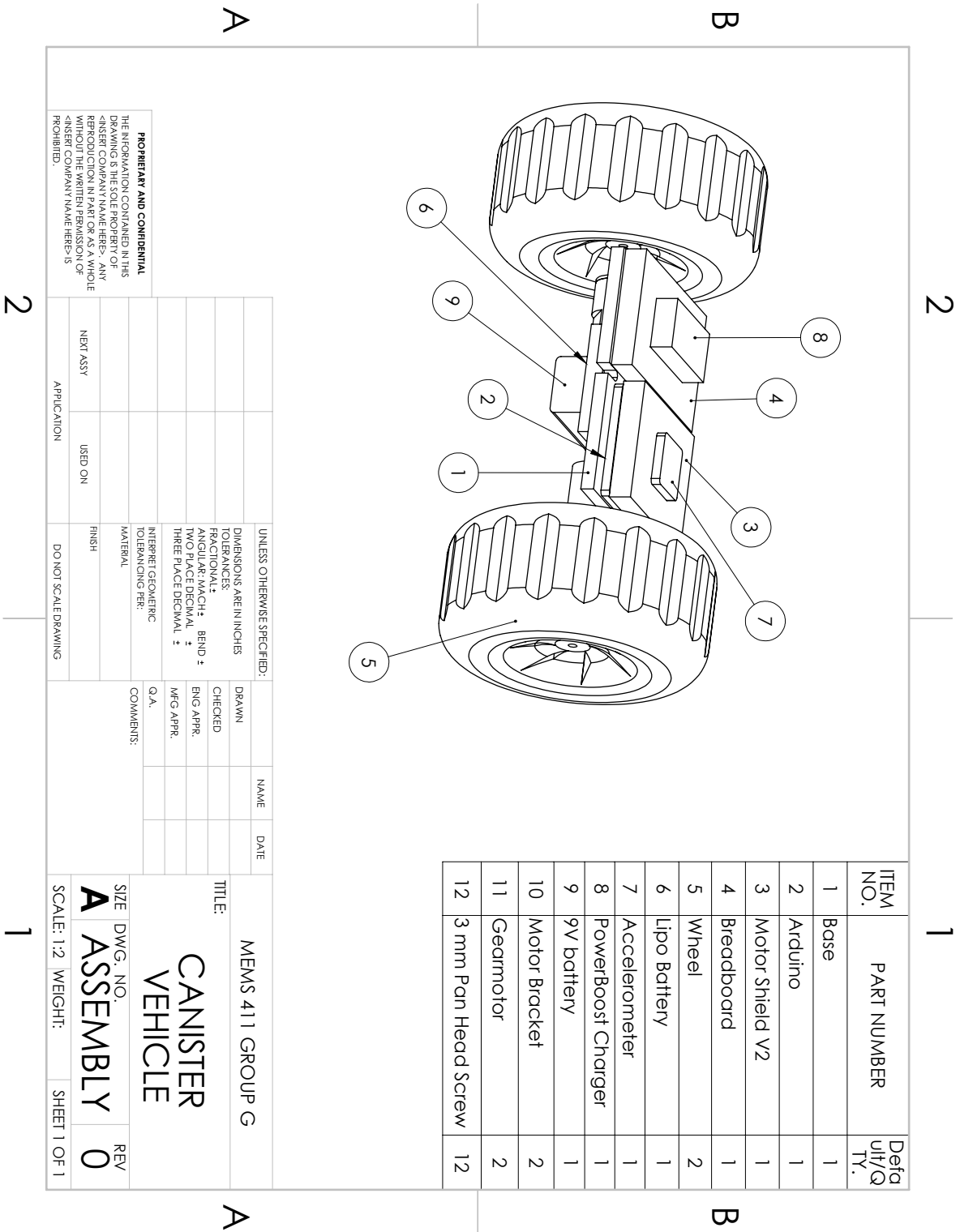
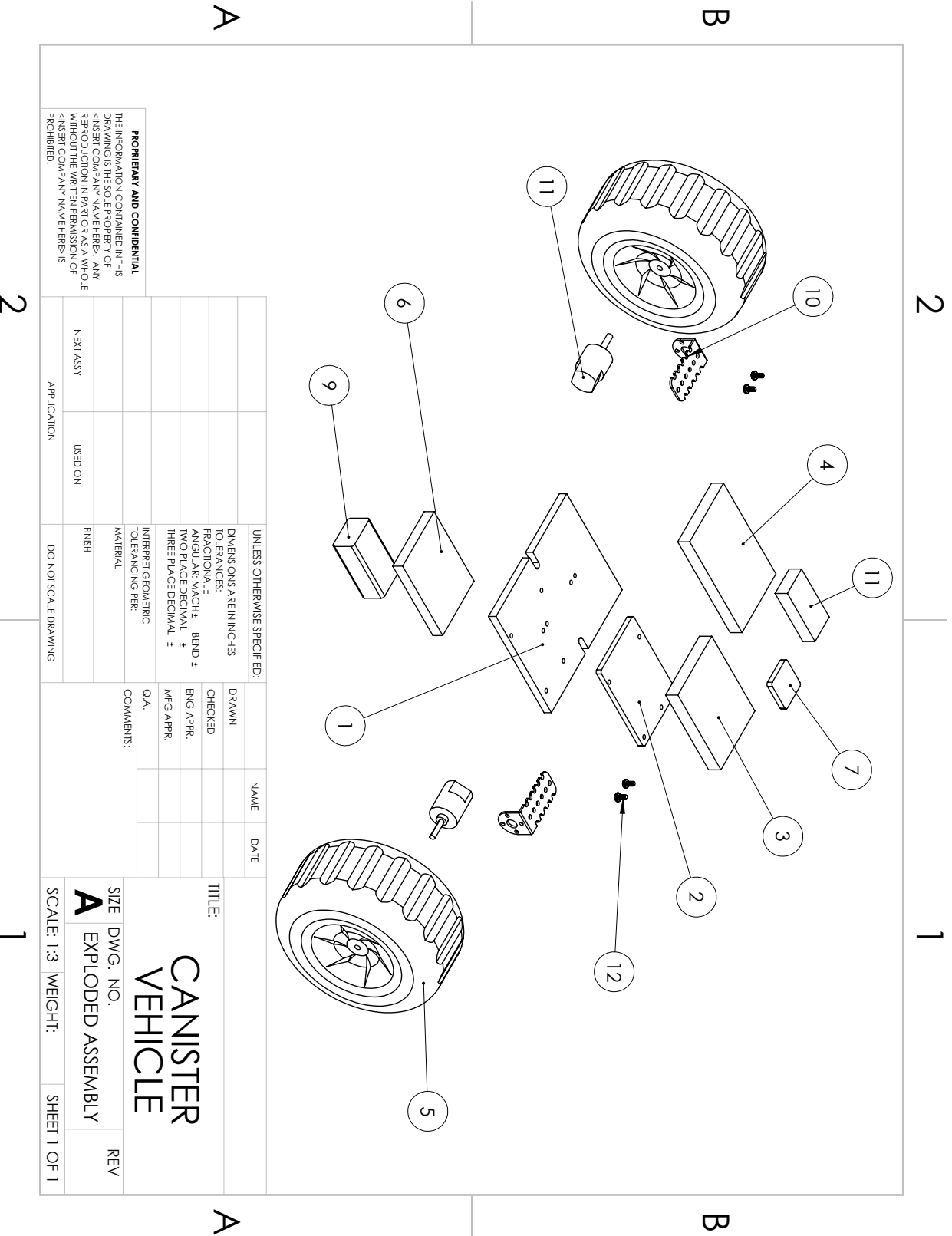

Figure 16: Assembly View with BOM



**PROPRIETARY AND CONFIDENTIAL**  
 THE INFORMATION CONTAINED IN THIS  
 DRAWING IS THE SOLE PROPERTY OF  
 <INSERT COMPANY NAME HERE>. ANY  
 REPRODUCTION IN PART OR AS A WHOLE  
 WITHOUT THE WRITTEN PERMISSION OF  
 <INSERT COMPANY NAME HERE> IS  
 PROHIBITED.

| UNLESS OTHERWISE SPECIFIED: |  | DRAWN   | NAME | DATE | TITLE:                      | SIZE     | DWG. NO. | REV |
|-----------------------------|--|---|------|------|-----------------------------|----------|----------|-----|
| DIMENSIONS ARE IN INCHES    |  | CHECKED   |      |      | <b>CANISTER<br/>VEHICLE</b> | <b>A</b> | DWG. NO. | REV |
| TOLERANCES:                 |  | ENG. APPR.  |      |      |                             |          |          |     |
| FRACTIONAL: ±               |  | MFG APPR.   |      |      |                             |          |          |     |
| ANGULAR: MACH ± BEND ±      |  | Q.A.  |      |      |                             |          |          |     |
| TWO PLACE DECIMAL ±         |  | COMMENTS:   |      |      |                             |          |          |     |
| THREE PLACE DECIMAL ±       |  | INTERPRET GEOMETRIC<br>TOLERANCING PER:<br>MATERIAL |      |      |                             |          |          |     |
| FINISH                      |  |   |      |      |                             |          |          |     |
| DO NOT SCALE DRAWING        |  |   |      |      |                             |          |          |     |
| USED ON                     |  |   |      |      |                             |          |          |     |
| APPLICATION                 |  |   |      |      |                             |          |          |     |
| NEXT ASSY                   |  |   |      |      |                             |          |          |     |

Figure 17: Exploded View



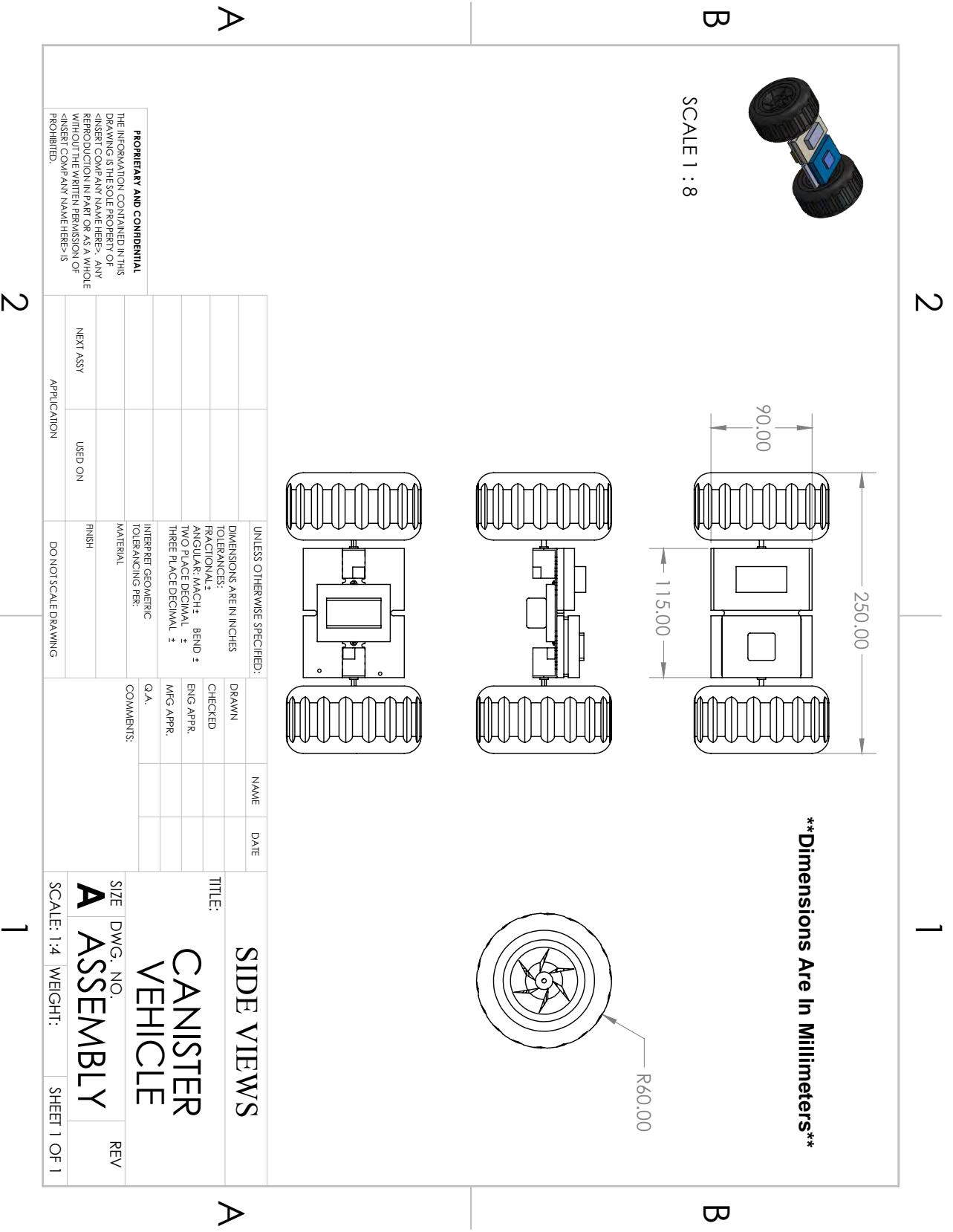

**PROPRIETARY AND CONFIDENTIAL**  
 THE INFORMATION CONTAINED IN THIS DRAWING IS THE SOLE PROPERTY OF [COMPANY NAME]. ANY REPRODUCTION IN PART OR AS A WHOLE WITHOUT THE WRITTEN PERMISSION OF [COMPANY NAME] IS PROHIBITED.

| UNLESS OTHERWISE SPECIFIED:          |             | DRAWN     | NAME | DATE |
|--------------------------------------|-------------|-----------|------|------|
| DIMENSIONS ARE IN INCHES             |             | CHECKED   |      |      |
| TOLERANCES:                          |             | ENG APPR. |      |      |
| FRACTIONAL ±                         |             | MFG APPR. |      |      |
| ANGULAR: MACH ± BEND ±               |             | Q.A.      |      |      |
| TWO PLACE DECIMAL ±                  |             | COMMENTS: |      |      |
| THREE PLACE DECIMAL ±                |             |           |      |      |
| INTERPRET GEOMETRIC TOLERANCING PER: |             |           |      |      |
| MATERIAL:                            |             |           |      |      |
| FINISH:                              |             |           |      |      |
| DO NOT SCALE DRAWING                 |             |           |      |      |
| USED ON                              | APPLICATION |           |      |      |
| NEXT ASSY                            |             |           |      |      |

|                  |  |            |          |              |
|------------------|--|------------|----------|--------------|
| TITLE:           |  | SIZE       | DWG. NO. | REV          |
| SIDE VIEWS       |  | A          | ASSEMBLY |              |
| CANISTER VEHICLE |  | SCALE: 1:4 | WEIGHT:  | SHEET 1 OF 1 |

Figure 18: Top/Side/Front Views w/Dimensions

Below is the initial list of parts for our proof of concept prototype.

**Table 6: Proof of Concept Parts List**

|    | Part Name                                  | Source Link   | Supplier Part Number | Color, TPI, other part IDs                    | Unit Price | Quantity | Total Price |
|----|--|---|----------------------|---|------------|----------|-------------|
| 1  | Arduino Board                              | <a href="https://www.adafruit.com/product/2488">https://www.adafruit.com/product/2488</a> | 2488                 | Adafruit Metro 328                            | 17.50      | 1.00     | 17.50       |
| 2  | Motor Shield V2                            | <a href="https://www.adafruit.com/product/1438">https://www.adafruit.com/product/1438</a> | 1438                 | Motor drivers                                 | 19.95      | 1.00     | 19.95       |
| 3  | GPS Unit                                   | <a href="https://www.adafruit.com/product/746">https://www.adafruit.com/product/746</a>   | 746                  | Adafruit, Arduino compatible                  | 39.95      | 1.00     | 39.95       |
| 4  | Triple-axis Accelerometer                  | <a href="https://www.adafruit.com/product/1120">https://www.adafruit.com/product/1120</a> | 1120                 | Adafruit, Arduino compatible                  | 14.95      | 1.00     | 14.95       |
| 5  | Motor Driver                               | <a href="https://www.adafruit.com/product/3190">https://www.adafruit.com/product/3190</a> | 3190                 | Adafruit, Arduino compatible                  | 7.50       | 2.00     | 0.00        |
| 6  | Half-size breadboard                       | <a href="https://www.adafruit.com/product/64">https://www.adafruit.com/product/64</a>     | 64                   | Adafruit, Arduino compatible                  | 5.00       | 1.00     | 5.00        |
| 7  | Dagu Wild Thumper Wheel                    | <a href="https://www.pololu.com/product/1555">https://www.pololu.com/product/1555</a>     | 1555                 | Red   | 14.95      | 1.00     | 14.95       |
| 8  | 2500 mAh LiPo Battery                      | <a href="https://www.adafruit.com/product/328">https://www.adafruit.com/product/328</a>   | 328                  | Adafruit, Arduino compatible                  | 19.95      | 1.00     | 19.95       |
| 9  | Pololu 20D mm Metal Gearmotor Bracket Pair | <a href="https://www.pololu.com/product/1138">https://www.pololu.com/product/1138</a>     | 1138                 | Pololu Motor brackets w/motor mounting screws | 6.95       | 1.00     | 6.95        |
| 10 | Pololu 20D mm Metal Gearmotor              | <a href="https://www.pololu.com/product/3488">https://www.pololu.com/product/3488</a>     | 3488                 | 62.5:1 metal spur gearbox                     | 22.95      | 2.00     | 45.9        |
| 11 | PowerBoost 1000 Charger                    | <a href="https://www.adafruit.com/product/2465">https://www.adafruit.com/product/2465</a> | 2465                 | Adafruit, Arduino compatible                  | 19.95      | 1.00     | 19.95       |
| 12 | Micro Servo High powered servo             | <a href="https://www.adafruit.com/product/2307">https://www.adafruit.com/product/2307</a> | 2307                 | Adafruit, Arduino compatible                  | 11.95      | 1.00     | 11.95       |
| 13 | M3 Screws                                  | <a href="https://www.am...ie=UTF8&amp;psc=1">https://www.am...ie=UTF8&amp;psc=1</a>       | GLLANLJM3            | M3 Screws, varied lengths, stainless steel    | 12.95      | 1.00     | 12.95       |

## 5.2 PROOF-OF-CONCEPT

Prototype performance goals:

1. The prototype can withstand a single drop from 1 meter on the turf. If the prototype is successful it will be drop-tested from 1 meter onto the track surface.
2. The prototype can travel one mile or 1.61 km on track surface without having the battery recharged
3. The prototype can travel 4.8 kph or 3 mph.

Design rationale for PoC components:

In Section 4.4 above, we described three engineering models/relationships that can be applied to our model to aid in the design process. The models and equations we chose allowed us to make calculations that confirmed our vehicle would meet its performance goals and led to decisions about the dimensions of certain parts.

The first model engineering model we described in section 4.4 was the impulse of the vehicle when the parachute started acting. Impulse is defined as  $\Delta p = F\Delta t = ma\Delta t$ . In our calculations below, we assumed  $\Delta t$  was 1s. Using the maximum allowed mass of the vehicle of 1.05 kg and acceleration due to gravity of  $9.8 \text{ m/s}^2$ , we calculated the impulse to be 10.29 N\*s.

The second model we described about was the equation for moment, which is  $M(r) = Fr$ . This equation proved to be quite useful in determining if the motors we wanted to order would provide a great enough force to the wheels to initially overcome the force of friction. We wanted to buy 2 motors to be applied to 2 wheels that each generated a moment of 4.2 kg\*cm, or .412 N\*m. The wheels we are using each have a radius of .06 m. Using the equation for moment, we calculated the force on each wheel from the motor to be 6.86 N, or 13.73 for both wheels. This is greater than the force of friction on the wheels, which we calculated to be 6.35 N.

The last model we described was the equation for drag force,  $F_D = .5 \rho C_D A v^2$ . This equation allowed us to determine the size of the parachute we needed. We first calculated the velocity of the vehicle. Because our performance goal stated our vehicle should be able to fall and land safely (without the parachute), we calculated the final velocity in that circumstance and used it in the equation for drag. Based on the information from a parachute website, we assumed the drag coefficient  $C_D$  to be .75. We used the density for air of  $1.225 \text{ kg/m}^3$ . And we set the drag force equal to the force of gravity because we are assuming the vehicle reaches its terminal velocity. From this, we calculated the required area of the parachute to be  $1.069 \text{ m}^2$ . Modeling the parachute as a semi-sphere, which has  $\text{Area} = 2\pi r^2$ , the parachute we need must have a radius of .412 m.

Calculations are shown below.

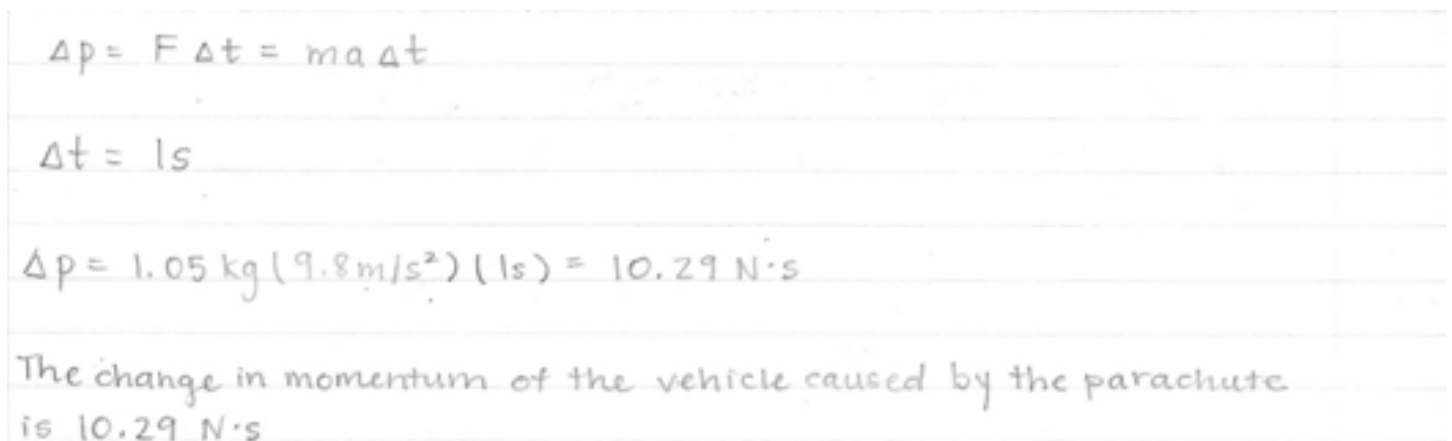

The image shows handwritten calculations on lined paper. The first line is the formula  $\Delta p = F \Delta t = ma \Delta t$ . The second line is  $\Delta t = 1s$ . The third line is the calculation  $\Delta p = 1.05 \text{ kg} (9.8 \text{ m/s}^2) (1s) = 10.29 \text{ N}\cdot\text{s}$ . The fourth line is a concluding sentence: "The change in momentum of the vehicle caused by the parachute is 10.29 N\*s".

Figure 19: Impulse Calculation

$$M(r) = F \cdot r$$

$$4.2 \text{ kg} \cdot \text{cm} = .41188 \text{ N} \cdot \text{m}$$

$$.41188 = F(.06 \text{ m})$$

$$F = 6.86 \text{ N / motor} = 13.73 \text{ N for 2 motors}$$

$$F_g = 1.05 \text{ kg} (9.8 \text{ m/s}^2) = 10.29 \text{ N}$$

The force generated by the motors on the wheels is greater than the weight of the vehicle!

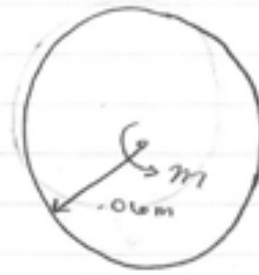

Figure 20: Momentum Calculation

$$F_g = F_d = \frac{1}{2} \rho C_d A v^2 \quad \rho_{\text{air}} = 1.225 \text{ kg/m}^3$$

$$C_d \text{ for parachute} = .75$$

$$v^2 = v_0^2 + 2a\Delta y \quad \Delta y = 1 \text{ m}$$

$$v = \sqrt{2(9.8 \text{ m/s}^2)(1 \text{ m})} = 4.427 \text{ m/s}$$

$$F_g = (1.05 \text{ kg})(9.8) = 10.29 \text{ N}$$

$$10.29 = \frac{1}{2} (1.225 \text{ kg/m}^3) (.75) A (4.427 \text{ m/s})^2$$

$$A = 1.069 \text{ m}^2$$

$$A \text{ of semi-sphere} = 2\pi r^2$$

$$1.069 \text{ m}^2 = 2\pi r^2$$

$$r = .412 \text{ m}$$

The parachute needs to have a surface area of  $1.069 \text{ m}^2$ , which is a radius of  $.412 \text{ m}$ .

Figure 21: Drag Force and Parachute Calculations

## 6 WORKING PROTOTYPE

### 6.1 OVERVIEW

The design evolved significantly from proof of concept to the working prototype. The working prototype was faster and more robust than proof of concept. Major changes to the design included remaking the base plate and motor brackets, increasing the voltage of the batteries, remodeling the tail, making a parachute release system, and modifying the layout. Changes are described below:

**Base Plate:** The base plate was originally made from wood with nuts press fit into the board. For the final design a custom base plate was manufactured from 3/16" aluminum with holes tapped for screws to secure the other parts.

**Motor Brackets:** The motor brackets we purchased for the proof of concept were too thin and plastically deformed during a drop test. To remedy this issue we manufactured new brackets from 1/8" aluminum angle bar.

**Batteries:** We originally used only one 3.7 V, 2500 mAh LiPo battery, which didn't provide enough voltage to 12V motors to run as fast as we needed. On the motor driver board we wired three JST connectors in series and powered the final design with three LiPo batteries.

**Tail:** To stabilize the rover on the proof of concept, a piece of sheet metal was attached to the back. Since the rover needs to fit in a canister during launch the tail needed to fold and then spring out when ejected. We met these requirements layering two strips of a measuring tape on top of each other and securing them to the bottom of the rover with a custom printed bracket.

**Parachute Release:** The parachute release was not a performance goal for the proof of concept, but a key aspect of the final design. The release mechanism need to be both secure when the rover was falling to the ground and release on impact. The final design had a hole in the base plate that the paracord looped through and was secured with a piece of zip tie cord. The cord was actuated with a servo motor that released the parachute on impact.

**Part Placement:** On the final design every part to be secured and fit on the board. Every part was screwed in and the batteries were attached with command strips. To prevent the Arduino board from making contact with the metal base plate, a piece of balsa wood was secured between them.

### 6.2 DEMONSTRATION DOCUMENTATION

Images of final working prototype:



Figure 22: Front Isometric View



Figure 23: Underside View



Figure 24: Rear View



Figure 25: Rear Isometric View



Figure 26: Front View

## 6.3 EXPERIMENTAL RESULTS

### Performance Goal #1: Drop Test

Our first prototype performance goal is that the rover can survive a drop of approximately 1 meter onto a hard surface. The rationale behind this goal is that if our rover were to compete, we would program the parachute to release when the rover is 1 meter above the ground, so that it can fall quickly and move out of the way of the parachute. Our rover must clear the parachute so that it does not get stuck underneath it. Our rover passed this performance goal extremely well; our custom motor brackets machined from 3/16" aluminum corners provided the required strength to keep the motors in place during the drop test.

### Performance Goal #2: Distance Requirement

Since the rover must travel under its own power from its landing spot to the intended location, we set a goal of providing enough battery power for it to travel one mile. To test this, we programmed the rover to run in a circle outside of the studio for 20 minutes (assuming it travels at approximately 3 miles per hour in this circle). To accomplish this, we throttled down one motor until the rover was traveling in a large circle. The rover was still moving after our 20-minute test and had not slowed down at all, meaning that the batteries were still providing an adequate voltage/current. Further, our calculations indicate our new battery supply has enough current to run the motors at stall current for at least one hour.

### Performance Goal #3: Speed

In order to facilitate a quick travel time, we decided that the rover should travel at least 3 miles per hour. Our proof of concept prototype traveled approximately 1.5 mph, and we found out that this was due to the batteries only supplying 5 volts to the motors, when we needed approximately 12 volts to get the motors up to their required speed. With our three-LiPo battery pack we were able to deliver over 11 volts to our motors. We soldered three JST connectors onto our motor shield and plug the batteries into it when we want to operate the rover. This allowed us to retain the ability to easily charge the rover battery pack via our JST LiPo chargers. Upon testing, we found our new battery supply gave the rover enough power to achieve our goal of 3 mph over several speed tests.



## 7 DESIGN REFINEMENT

### 7.1 FEM STRESS/DEFLECTION ANALYSIS

During our initial drop tests, we noticed that the motor brackets bent significantly after the vehicle was dropped from our specified height. We decided to perform a FEA on this component so that we could design the part to not bend.

#### Mesh, Load and Boundary Condition Description

- We chose a slightly coarser mesh due to the fact that the part does not have angled surfaces and our analysis only contains one load. The bottom surface of the bracket is fixed to model it being attached to the body of the vehicle. The load on the bracket due to the drop is modeled as a moment applied about the interface of the motor and the motor bracket. To estimate the magnitude of the moment we calculated the impact force from the vehicle falling onto a hard surface from 1 meter and estimated the deflection of the tires due to the fall. We also measured the distance from the motor/bracket interface to where the axle connects to the wheel to estimate the moment axis. See the figure below for a visual representation of the loading scenario. We believe that these conditions accurately model the machine's expected operating conditions because of our load calculations and the similarity between the deflection we saw on the actual model and our simulation results.

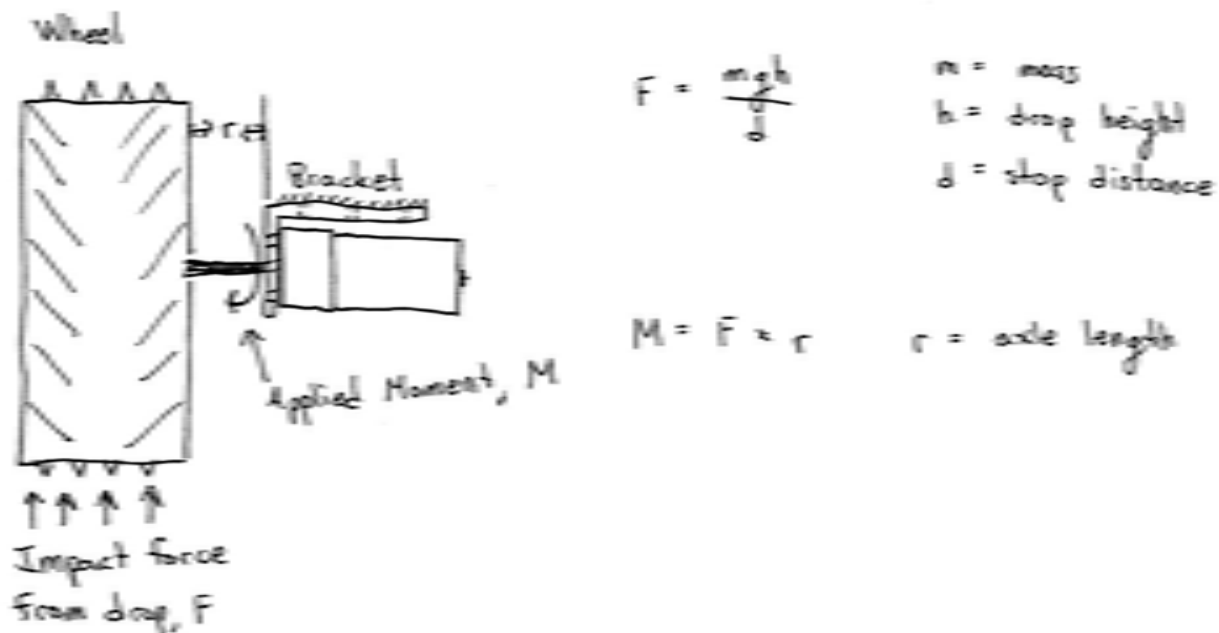

Figure 27: FEA Loading Scenario and Calculations

## Simulation Results

See below the results of our simulation



Figure 28: Unloaded model with mesh, loads and boundary conditions

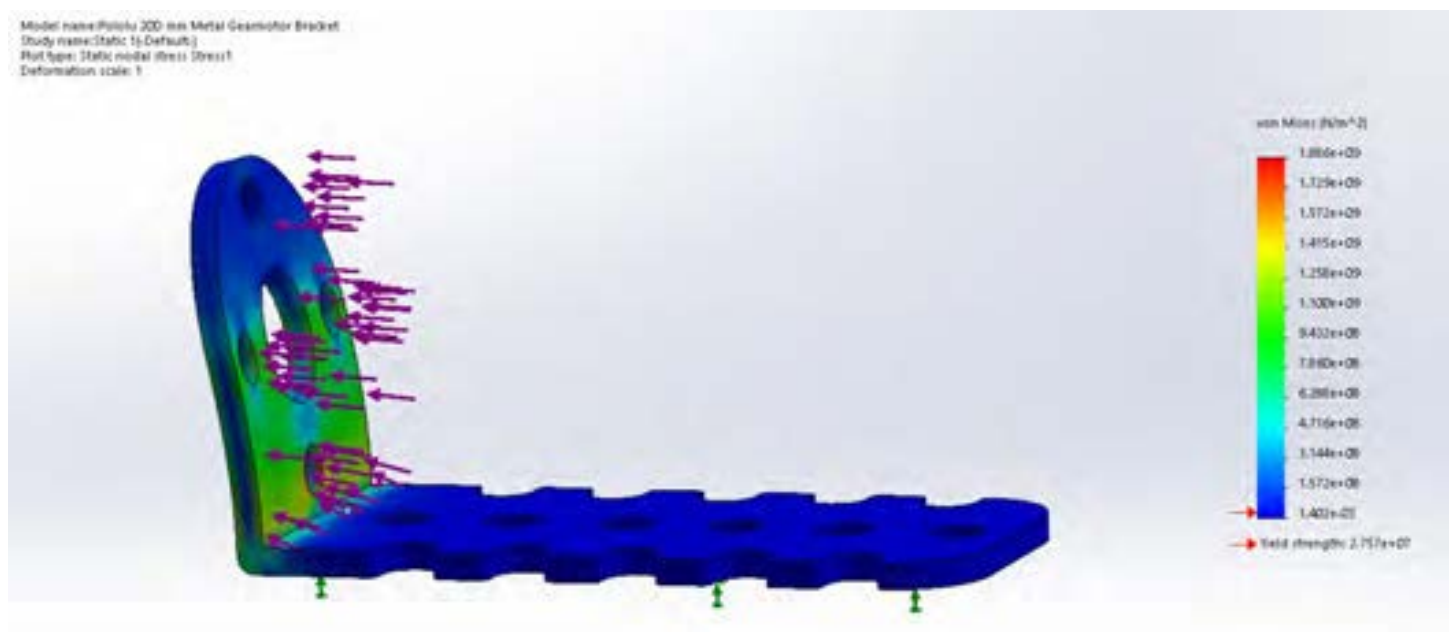

Figure 29: Von Mises stress plot

Model name: Pololu 200 mm Metal Gearmotor Bracket  
Study name: Static 1 (Default)  
Plot type: Static displacement (Displacement)  
Deformation scale: 1

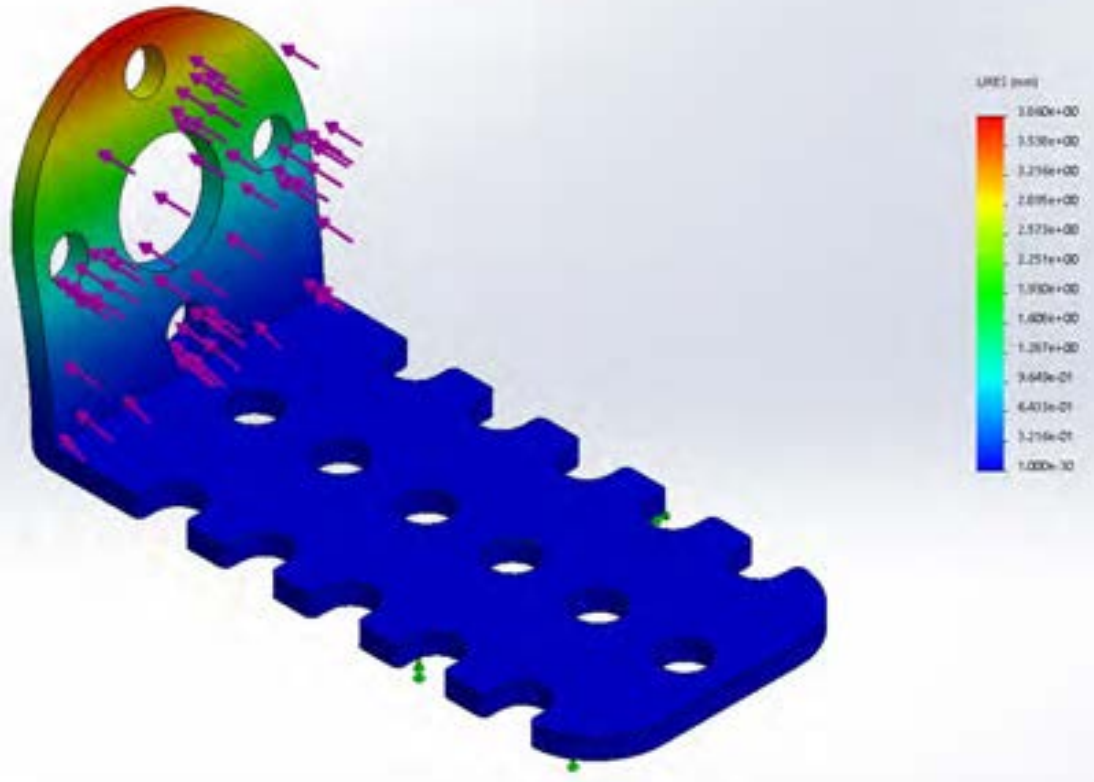

Figure 31: Isometric displacement plot

Model name: Pololu 200 mm Metal Gearmotor Bracket  
Study name: Static 1 (Default)  
Plot type: Static displacement (Displacement)  
Deformation scale: 1



Figure 30: Side-view of displacement plot

## Interpretation

It is more useful to analyze the deflection in this simulation since the stress is not high enough to break the motor brackets. Further, deflection of the motor brackets has a direct impact on the alignment of the wheels and the drivability of the vehicle. We determined that a deflection of more than 1 mm at the tip of the motor bracket is unacceptable, due to the reduction in contact area of the wheels on the ground. This simulation shows a maximum deflection of over 3.50 mm (see figure 23) which is unacceptable. The motor brackets will be redesigned in future models to properly account for the impact force.

## 7.2 DESIGN FOR SAFETY

### 7.2.1 LiPo Battery Risk

**Risk Name:** LiPo Battery

**Description:** The LiPo battery has a risk of exploding if it gets punctured. The rover has no navigation system when parachuting down from the rocket, so there is no way to prevent it from falling on a sharp rock or object. This could potentially puncture the battery.

**Impact: (5)** If the LiPo battery is punctured and explodes, the results would be catastrophic if there are people handling the rover. Injuries could range from skin irritation to serious burns.

**Likelihood: (2)** Even if a rock hits the LiPo battery while the vehicle is traveling on the ground, it most likely would not be sharp enough or hit hard enough to puncture the battery. So there is only a medium-low likelihood that this would happen.

### 7.2.2 Parachute Malfunctions Risk

**Risk Name:** Parachute Malfunctions

**Description:** When the rover is ejected from the rocket, a parachute is supposed to deploy to slow the fall of the vehicle. If the parachute malfunctions, the rover would land at a significantly higher speed with a much greater impact.

**Impact: (5)** If the vehicle landed at its terminal velocity without the parachute, it would have a catastrophic effect if it landed on someone. If the impact is large enough, it could cause the LiPo battery to explode. Further, depending on where it landed, it could cause damage to equipment on site.

**Likelihood: (3)** There is a medium likelihood that this would occur. There are many ways for the parachute to malfunction or not deploy correctly. And we would not have the opportunity to test the parachute at the altitude it would need to deploy in the competition, so there is no way to ensure it works.

### 7.2.3 Open Wiring Risk

**Risk Name:** Open Wiring

**Description:** Because of size and weight constraints some of the wiring is exposed. If someone were to improperly connect wires, it could cause damage to the rover. Further, if the rover got wet in competition, it could cause it to malfunction.

**Impact: (2)** The risk to someone's health is relatively low since the rover is powered by a 3.7 V LiPo battery

**Likelihood: (1)** Since the competition takes place in a desert and operated by experienced individuals the likelihood of this being an issue is low.

### 7.2.4 Rover Runs into a Person Risk

**Risk Name:** Rover Runs into a Person

**Description:** During the ARLISS competition, the parachute travels on the ground after it lands. While the vehicle is moving, it could run into one of the participants or observers of the competition.

**Impact: (1)** Because the rover will only be moving at 3 mph, it would not significantly hurt anyone it runs into.

**Likelihood: (2)** Unless the observers are very close and distracted while following the rover, most people would be able to get out of the way before coming in contact with it. So the likelihood is medium-low.

### 7.2.5 Rover Falls on a Person Risk

**Risk Name:** Rover Falls on a Person

**Description:** When the rover is ejected from the rocket, a parachute will deploy and slow its descent. When it hits the ground it will be falling at an estimated 4.4 m/s.

**Impact: (4)** If the rover were to fall on someone, it could cause significant harm.

**Likelihood: (1)** Since testing will be taking place in the Black Rock desert where no one lives. Further, all participants in the competition will be aware of the rocket launch, so the risk of the rover falling on someone is low.

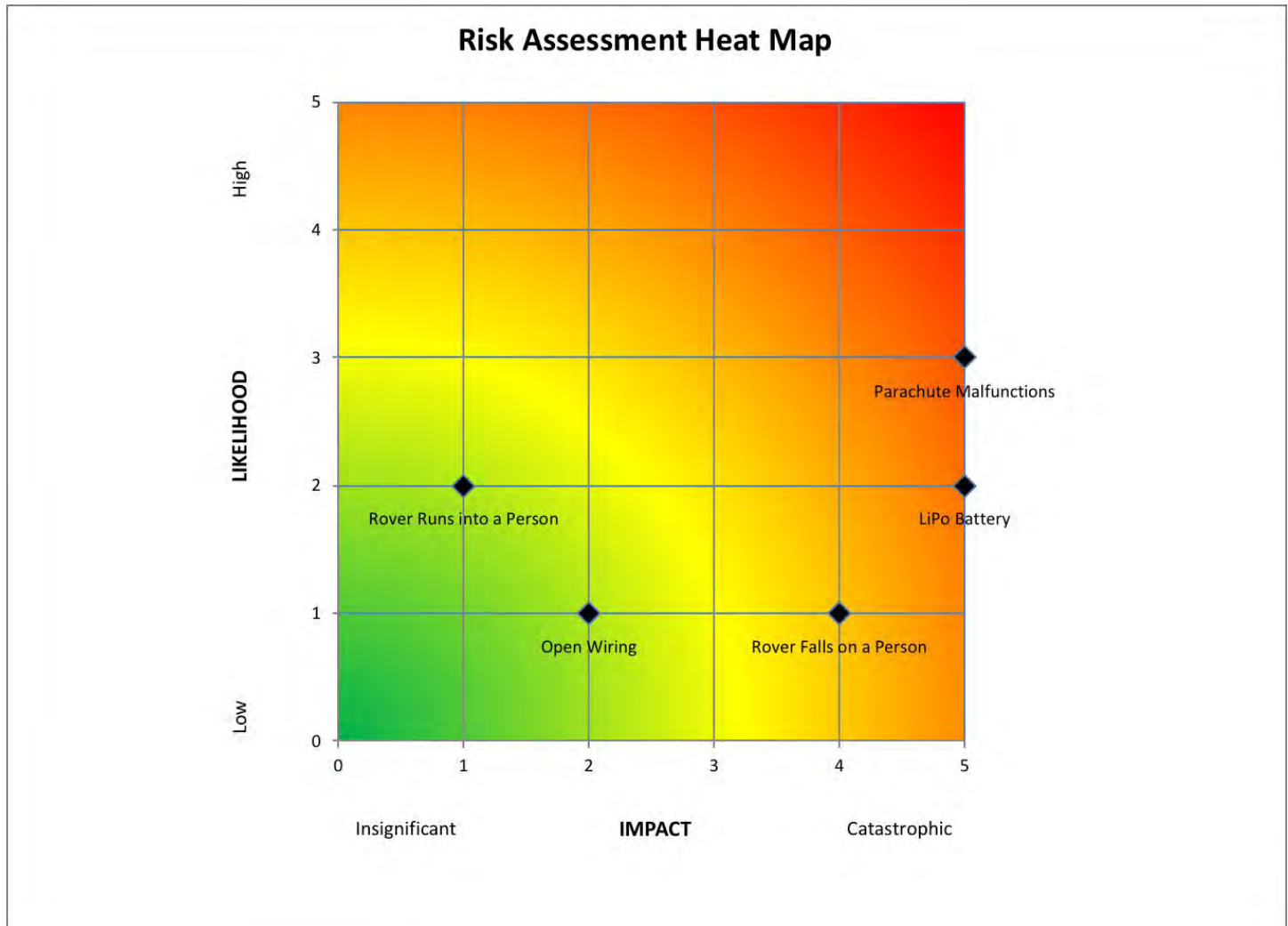

Figure 32: Risk assesment heat map

The highest priority risk, as dictated by the heat map, is parachute malfunctioning. The reason why this is the highest priority is because there would be a catastrophic impact if the parachute malfunctions, and it is a problem that is more likely to occur than many of the other risks we identified. The next highest priority is the LiPo battery. If the LiPo battery gets punctured while the vehicle is traveling, the battery would explode and have a catastrophic impact. However, this is not something that is likely to occur. The next highest risk is the rover falling onto a person. The risks of open wiring and the rover running into a person are tied for the lowest risks. Although the open wiring has a bigger impact, the rover running into a person is more likely occurred, so these balance out on the heat map.

## 7.3 DESIGN FOR MANUFACTURING

### 7.3.1 Draft Analysis

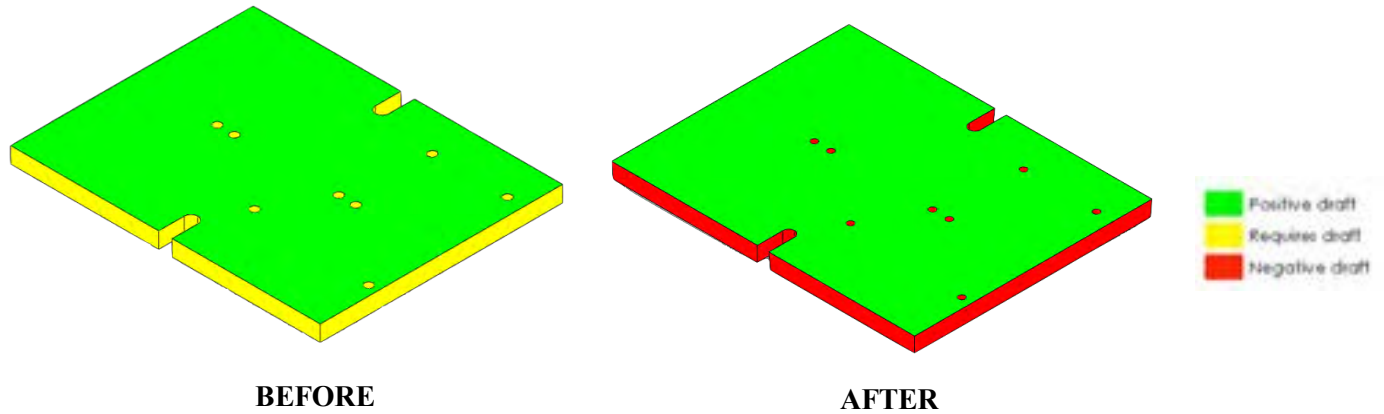

Figure 33: Draft Analysis

We performed a draft analysis on the base plate of our design. We used the drafting tool on SolidWorks; we selected the direction of the pull and the faces. We used a draft angle of 3 degrees. Realistically, however, injection molding is not a process we would utilize in manufacturing this part.

### 7.3.2 DFM Analysis

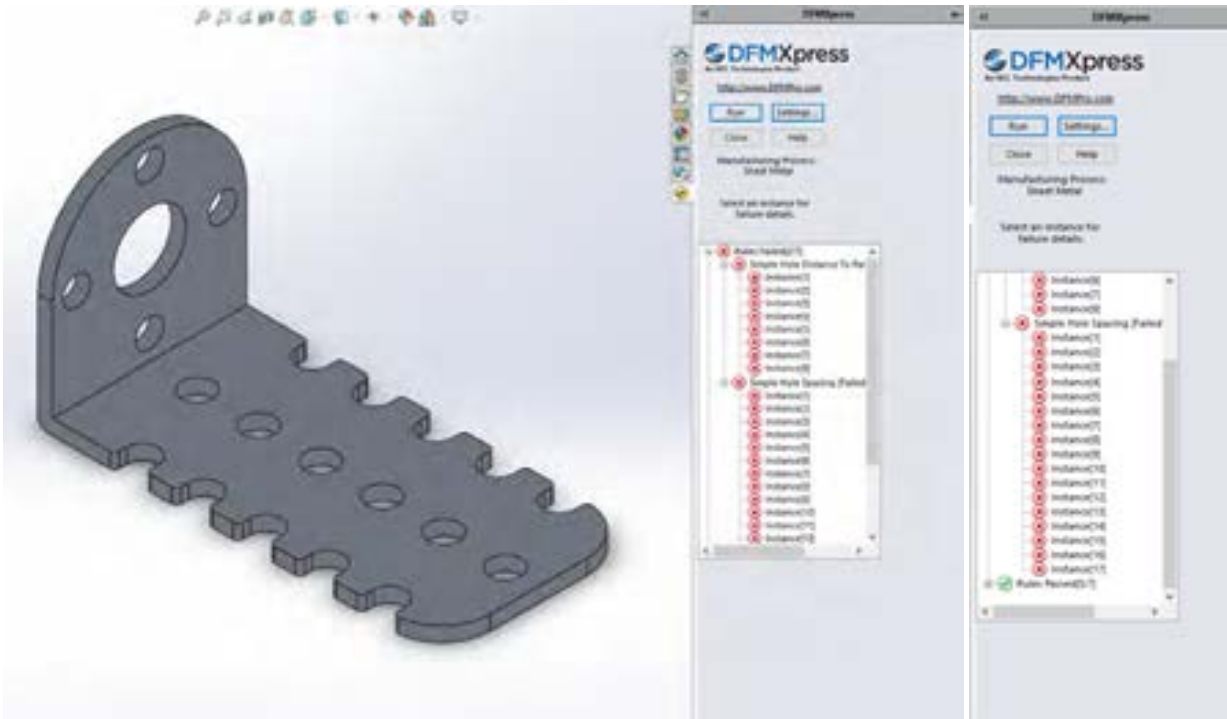

Figure 34: DFM Sheet Metal Analysis

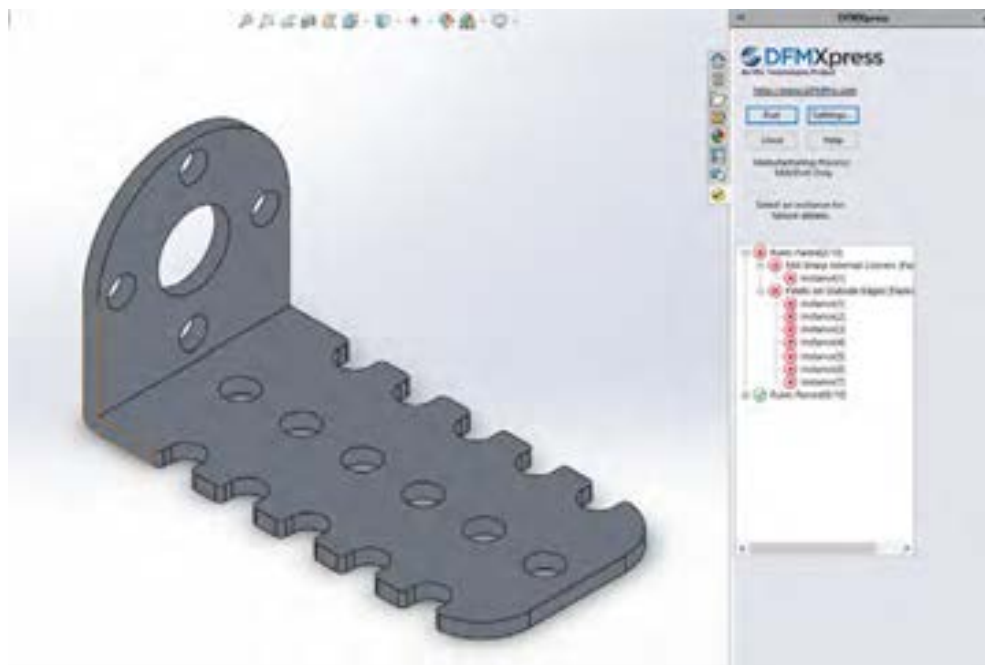

Figure 35: DFM Mill and Drill Analysis

The bracket was analyzed for Sheet Metal and Mill and Drill. Milling and drilling was suitable for all of the wholes, but it was not suitable for the 90 degree bend. To manufacture this part it would need to be bent as sheet metal and the holes would be milled/drilled.

#### **7.4 DESIGN FOR USABILITY**

We want users of all types to be able to use our vehicle. There are different components of the design that can be changed to allow users with various types of impairments to operate the vehicle (and participate in the ARLISS competition).

Someone with a vision impairment would have a difficult time following the vehicle throughout the ARLISS competition. Because the vehicle is launched thousands of feet in the air before it lands on the ground and begins traveling to the specified GPS coordinate, someone with a vision impairment would not be able to see when and where the vehicle lands. Although this wouldn't affect the functionality of the autonomous vehicle, we could add a buzzer onto the device that sounds when the device lands. With a buzzer that sounds when the vehicle lands, even people with vision impairments would know where the device ends up.

Similar to someone with a vision impairment, someone with a hearing impairment might also have a difficult time locating the device when it lands if the vehicle lands out of the line of sight of the person operating it. Because of this issue that could arise, we could attach a light that blinks when the vehicle lands to make it easier to track for everyone, especially those with hearing impairments.

There are many small switches on our device that must be turned on for the vehicle to operate. Turning off and on these small switches would be very difficult for someone with a physical impairment such as arthritis. In order to make the device easier to turn on for someone with arthritis, the best solution would be to use larger switches.

Someone with a language impairment, such as speaking little or no English, would not affect the usability of the device or someone's ability to participate in the ARLISS competition. Language is not an important part of the design, nor does the device require much instruction to operate. A simple switch turns the device on and off. There are no modifications that need to be made for someone with a language impairment.

A control impairment might cause issues during the ARLISS competition. If someone is distracted while they are following and tracking the device on the ground, they might run into the vehicle and send it off the path it was traveling. However, because the vehicle is traveling towards a GPS coordinate autonomously, this will not create a problem with the vehicle arriving at its designated target. Therefore, there are no design modifications that need to be made for someone with a control impairment.



## 8 DISCUSSION

### 8.1 PROJECT DEVELOPMENT AND EVOLUTION

#### 8.1.1 Does the final project result align with its initial project description?

Our final project aligns very nicely with the initial project description. Our task was to design a rover that would be a viable competitor in the ARLISS competition. Specifically, our task was to design a vehicle within size and weight restrictions that could theoretically compete with other teams. The programming to create an autonomous rover is beyond the scope of this course, and it was decided that we would not create an autonomous rover.

We are confident that our rover would be competitive in the open class ARLISS competition. We designed a rover that fits within the open-class canister and is well under the weight limit. The RC monster truck wheels we chose were a risky choice because of the low-quality interface between the wheels and motor shaft hub, but once properly mounted they provided fantastic traction and allowed the rover to traverse rough terrain. Our stabilizing tail (made out of segments of a tape-measure) works great and provides plenty of stabilizing force, especially with our 3D printed mounting piece. The parachute release mechanism we designed with a servo motor, zip tie and Kevlar rope was simple but very effective. With the proper sensors and coding to create the autonomy required, our project would be a viable competitor at ARLISS.

#### 8.1.2 Was the project more or less difficult than expected?

We began our project knowing that it was going to be very time-intensive. We thought that the process was going to be very linear, meaning that we would go through each assignment for the project one step at a time and gradually move forward until we produced a working prototype. We did not anticipate the various obstacles, both small and large, that would come along for each step of the project. One of the biggest difficulties we underestimated at the beginning was simply deciding which parts we needed to order to assemble the prototype. For example, we had to decide between different Arduino boards, motors and motor brackets, wheels, and batteries. We also had to decide which parts we needed to order versus what we could machine or 3D print. Machining various parts of the prototype also proved to be more difficult than expected. A large reason for this difficulty was the logistics of coordinating when the machine shop would be open for us to use during our various schedules. The last big obstacle that came up that we did not anticipate was when the parts we ordered or machined failed to work in the way we wanted them to. The LiPo battery we ordered did not provide the full voltage the motors were capable of operating at. The motor brackets did not allow the motors to screw in properly, so we had to machine our own. And in the week leading up to the expo, we had to order a new motor. Overall, the project was more difficult than we expected, but there was no way to anticipate the difficulties that arose throughout the semester.

#### 8.1.3 On which part(s) of the design process should your group have spent more time? Which parts required less time?

Our group should have spent more time on the concept generation and concept selection part of the design process. During the interview with our customer, Dr. Potter, we discussed that the most successful designs consisted of 2 wheels on the ends of a base plate. After learning about the most successful canister vehicles, we decided to model our canister vehicle to align with the designs of previously successful models. Because we knew of successful designs, we focused our attention on how we could recreate and improve an already existing design instead of generating new concept ideas.

The only part of the project that possibly could have taken less time was machining the base plate and motor mounts; the machine shop was not open at the times we needed access, so a lot of time was spent waiting. The wait times caused the entire process to take longer; had we been more aware of the machine shop schedule our time could have been better scheduled and budgeted. Another area in which we lost a small amount of time was in dis-assembling and re-

assembling the vehicle multiple times to test each new part. To reduce the amount of time spent in assembly we could have better planned our objectives and part testing to test

#### 8.1.4 Was there a component of the prototype that was significantly easier or harder to make/assemble than expected?

There were a few components of the prototype that were more difficult to assemble/make. The wiring proved to be more difficult than expected. The wires connecting to the motors kept coming apart, and we had to solder them again and again, ultimately needing to order a new motor because the solder was not holding. The parachute release mechanism was not very difficult to assemble once we knew how to best approach it, but it did require a lot of time and brainstorming to think of a release mechanism that worked the way we needed it to. Another difficulty of the design process we did not anticipate was controlling the vehicle to move straight. The motor shaft adaptor did not fit tightly into the wheel, so we had to change the speeds of the motors using the Arduino board.

The base plate was easier to make than we had anticipated. We initially thought we would need a more complicated base plate, but the simplicity of our design was very functional and effective. The tail was also easier to design than we expected. Using a tape measure allowed the vehicle to move forward and fold up to stay within the required dimensions.

#### 8.1.5 In hindsight, was there another design concept that might have been more successful than the chosen concept?

Based on the limitations of a \$250 budget and a timeframe of one semester, we could not have chosen a more successful design concept. Our canister vehicle met and even exceeded our goals. Our design was able to be dropped from one meter without sustaining damage that would impede its maneuvering abilities, travel more than one mile on its battery life, and travel at a speed of 3 miles per hour. Choosing a more advanced or complicated design would have quickly put us over budget, especially considering that even with our current design we maxed out our budget. For example, if we were to design our canister vehicle to be similar to the Sphero, we would have needed to purchase an expensive gyroscope; after the initial purchase, our group would have to have spent a significant amount of time developing an understanding of how to use it. Additionally, our design provides better traction, allowing it to travel smoothly over rough terrain. The other design concepts we considered would not have been able to drive up the Lopata hill as successfully as our final design. While we could have spent more time on our concept generation, we could not develop and design concepts that would have better fulfilled our project goals, especially when considering the scope of the project.

## 8.2 DESIGN RESOURCES

### 8.2.1 How did your group decide which codes and standards were most relevant? Did they influence your design concepts?

Our design concepts were not heavily influenced by codes and standards. Our project is unique in that its end user is the build team (i.e. this is not a consumer product) and any standards that the project had to meet were dictated by the competition guidelines. This is not a product that would need to be manufactured in large quantities or used by individuals with limited knowledge of the components. If this were a consumer product (like the Sphero toy examined in examined in the problem understanding section) we would have considered more safety and reliability standards.

Because our standards were given in the competition rules, our design influences stemmed from the weight and size requirements of the vehicle. For example, we had to shorten the motor shafts and place the motor bracket holes closer together on the baseplate in order to shorten the overall length of the vehicle. Additionally, we chose our wheels based on the diameter limit of the open class competition. And the placement of the electrical components was driven by the diameter limitations. We made sure to place all components within the circumference that the wheels enclosed so that the

rover could land upside down and retain the ability to move. We also minimized the number of extra manufactured parts to reduce the weight of the rover.

### 8.2.2 Was your group missing any critical information when it generated and evaluated concepts?

We were not missing any critical information about the ARLISS competition, its requirements, or its dimension specifications when we started generating or evaluating concepts. Before we even considered concepts, we read various documents and visited websites that described the nuances of the competition in detail. We knew exactly what the vehicle was supposed to do, how we modified the requirements of the competition based on the time restriction of the class, and the required dimensions of the open class. The big issue that arose when we were generated and evaluated concepts was that we already had our final concept in mind before we brainstormed alternatives. When we had our customer interview with Dr. Potter, he said that the most successful designs he has seen at the competition entail a base with two wheels and a tail to cause the necessary torque to propel the vehicle forward (instead of causing the base to rotate). After our interview, we decided definitely to design our vehicle in this way. Because of that, we failed to brainstorm other concepts. Although our concept was very successful and met all of our performance goals, we probably could've designed a vehicle based on a different concept that would have also been successful.

### 8.2.3 Were there additional engineering analyses that could have helped guide your design?

The engineering relationships we analyzed in Section 4 proved to be very useful in designing our vehicle. The impulse relationship did not change or help our design in any way and was not ultimately necessary. The moment relationship did help us make important decisions. We used this relationship to determine if the motors we wanted to order would provide a great enough force to the wheels to overcome this force of friction. From this relationship, we were able to decide what motors to order. We could have applied this relationship to the tail, to determine if the friction from the tail would provide enough torque such that the vehicle propelled forward instead of the base plate rotating. Although we did not use an engineering model to generate the tail, we were able to design a tail successfully. The drag force equation also proved to be very useful in deciding the size of the parachute we need to order. Although we could not test if that parachute allowed the vehicle could withstand a fall from 10,000 feet, we tested the parachute with a 1 kg weight by dropping it from the 4<sup>th</sup> floor of Jolley, and it functioned very well. Aside from the engineering models we utilized in Section 4, there were no engineering analyses that were integral to generating a successful prototype, as evidenced by our vehicle reaching all of the performance goals. While we could have applied various equations to prove the vehicle's ability to reach the performance goals, they were not necessary.

### 8.2.4 If you were able to redo the course, what would you have done differently the second time around?

We would have structured our design process a little better in the early stages. It would have been beneficial to work a Gantt chart into our process in the early design phases, so we could have gotten to work on the prototype sooner. Items such as research of similar design are not as valuable as iterating our own design so that we could get a sense of how to build our prototype. It would have been a good idea to have made one more mockup of the design where we cut out the shapes of our various components from foam core (or a similar material) and placed them together on our base plate. Part of the reason we did not prototype in this manner was because we had to do extensive research on the proper electrical components to buy. Therefore, we did not know what kind of spatial organizing we would have to do until later

in the course. It would have been very useful to have spoken extensively with a faculty member that had experience with Arduino and small robotic components. That would have allowed us to make decisions regarding the parts we ordered sooner and allowed for at least one more iteration of the prototype.

### 8.2.5 Given more time and money, what upgrades could be made to the working prototype?

With more time and resources, our group would have been able to design an enclosure for the motors and Arduino boards. This would provide protection from dust and dirt and increase the life of the rover. Furthermore, although the wheels provided great traction and resistance to impact, the interface between the hubs and axels was plastic and not straight. This caused the wheels to wobble and veer off center. Since the rover was under the weight requirement, we would have purchased metal wheels so they would have a better and stronger connection interface.

A larger budget would have allowed us to purchase the necessary components to make the rover autonomous. This would require a GPS and logging module, accelerometer, magnetometer, altimeter, and IR sensor. We would also have needed more time to learn more about these components and how to program them because we did not have a lot of programming experience before. Fortunately, when designing the baseplate for our working prototype we left space for these components to be added in later iterations. Lastly, the rover would be tested to simulate actual launch conditions. To achieve this, the rover could be lifted to 10,000 feet using a weather balloon. Then it would be released and the parachute mechanism could be tested.

## 8.3 TEAM ORGANIZATION

### 8.3.1 Were team members' skills complementary? Are there additional skills that would have benefitted this project?

The team members' skills were very complementary. Where one group member lacked, another excelled. Each team member brought something different to the table that helped the group be successful. The group worked well together and made the project more fun and interesting than it could have been. Because our group was friends before the project, we were able to communicate comfortably and complete the project without any animosity or added awkwardness in the beginning stages of the project.

The team would have benefited from additional knowledge of electrical components. None of us had ever worked on any type of rover so it took a lot of time to develop a parts list. Once our parts came in, we spent a lot of time trying to figure out how the batteries would connect to the motors, motor shield, and servo. We initially purchased a powerboost that was supposed to step up the voltage to 5V but the motors worked at full capacity at 12V, so we realized that our canister vehicle was not reaching its maximum speed or power. Not everyone in the group was familiar with Arduino so the work associated with programming with the Arduino was not evenly dispersed.

### 8.3.2 Does this design experience inspire your group to attempt other design projects? If so, what type of projects?

This project gave our group great experience working with small robotic components. None of our team members had done projects with Arduino components in this capacity. For example, knowing how to use Arduino would allow us to program a smart home with technologies like Alexa. Further, learning how to run multiple motors off of one Arduino board (with the help of a motor shield) is extremely useful. The platform we created can be used as the base component set for numerous kinds of projects. We actually hope to connect our GPS sensor and code in the autonomous location finding feature of the rover next semester.

We also gained extensive experience in the machine shop by fabricating our custom parts. Becoming familiar with mills and lathes allowed us to achieve another level of precision similar to that of store-bought parts.

## APPENDIX A – COST ACCOUNTING WORKSHEET

|    | Part Name                              | Source Link   | Supplier Part Number | Color, TPI, other part IDs                 | Unit Price | Quantity | Total Price |
|----|--|---|----------------------|--|------------|----------|-------------|
| 1  | Arduino Board                          | <a href="https://www.adafruit.com/product/2488">https://www.adafruit.com/product/2488</a>   | 2488                 | Adafruit Metro 328                         | 17.50      | 1.00     | 17.50       |
| 2  | Motor Shield V2                        | <a href="https://www.adafruit.com/product/1438">https://www.adafruit.com/product/1438</a>   | 1438                 | Motor drivers                              | 19.95      | 1.00     | 19.95       |
| 3  | Dagu Wild Thumper Wheel                | <a href="https://www.pololu.com/product/1555">https://www.pololu.com/product/1555</a>   | 1555                 | Red  | 14.95      | 1.00     | 14.95       |
| 4  | 2500 mAh LiPo Battery                  | <a href="https://www.adafruit.com/product/328">https://www.adafruit.com/product/328</a>   | 328                  | Adafruit, Arduino compatible               | 19.95      | 3.00     | 59.85       |
| 5  | Pololu 20D mm Metal Gearmotor          | <a href="https://www.pololu.com/product/3488">https://www.pololu.com/product/3488</a>   | 3488                 | 62.5:1 metal spur gearbox                  | 22.95      | 2.00     | 45.9        |
| 6  | PowerBoost 1000 Charger                | <a href="https://www.adafruit.com/product/2465">https://www.adafruit.com/product/2465</a>   | 2465                 | Adafruit, Arduino compatible               | 19.95      | 1.00     | 19.95       |
| 7  | Micro Servo High powered servo         | <a href="https://www.adafruit.com/product/2307">https://www.adafruit.com/product/2307</a>   | 2307                 | Adafruit, Arduino compatible               | 11.95      | 1.00     | 11.95       |
| 8  | M3 Screws                              | <a href="https://www.am...ie=UTF8&amp;psc=1">https://www.am...ie=UTF8&amp;psc=1</a>   | GLLANLJM3            | M3 Screws, varied lengths, stainless steel | 12.95      | 1.00     | 12.95       |
| 9  | 36" Printed Nylon Parachute            | <a href="https://www.apogeerockets.com/Building-Supplies/Parachutes/Larger-than-24in/36in-Printed-Nylon-Parachute">https://www.apogeerockets.com/Building-Supplies/Parachutes/Larger-than-24in/36in-Printed-Nylon-Parachute</a>           | 29095                | Orange                                     | 16.80      | 1.00     | 16.80       |
| 10 | 220# Ball Bearing Swivel               | <a href="https://www.apogeerockets.com/Building-Supplies/Parachutes/Recovery_Equipment/Swivels/200_Ball_Bearing_Swivel">https://www.apogeerockets.com/Building-Supplies/Parachutes/Recovery_Equipment/Swivels/200_Ball_Bearing_Swivel</a> | 14510                | Silver                                     | 4.37       | 1.00     | 4.37        |
| 11 | JST-PH 2-Pin SMT Right Angle Connector | <a href="https://www.adafruit.com/product/1769">https://www.adafruit.com/product/1769</a>   | 1769                 | Black                                      | 0.75       | 3        | 2.25        |
| 12 | Anvil 25 ft. Tape Measure              | <a href="https://www.homedepot.com/p/ANVIL-25-ft-Tape-Measure-076002270/302752028">https://www.homedepot.com/p/ANVIL-25-ft-Tape-Measure-076002270/302752028</a>   | 076002270            | Green and grey                             | 4.97       | 1        | 4.97        |
| 13 | Kevlar Cord 100#                       | <a href="https://www.apogeerockets.com/Building-Supplies/Parachutes/Recovery_Equipment/Shock_Cord/Kevlar_Cord_100">https://www.apogeerockets.com/Building-Supplies/Parachutes/Recovery_Equipment/Shock_Cord/Kevlar_Cord_100</a>           | 30325                | 100 lb test strength braided cord          | 0.34       | 20       | 6.80        |

# APPENDIX B – FINAL DESIGN DOCUMENTATION

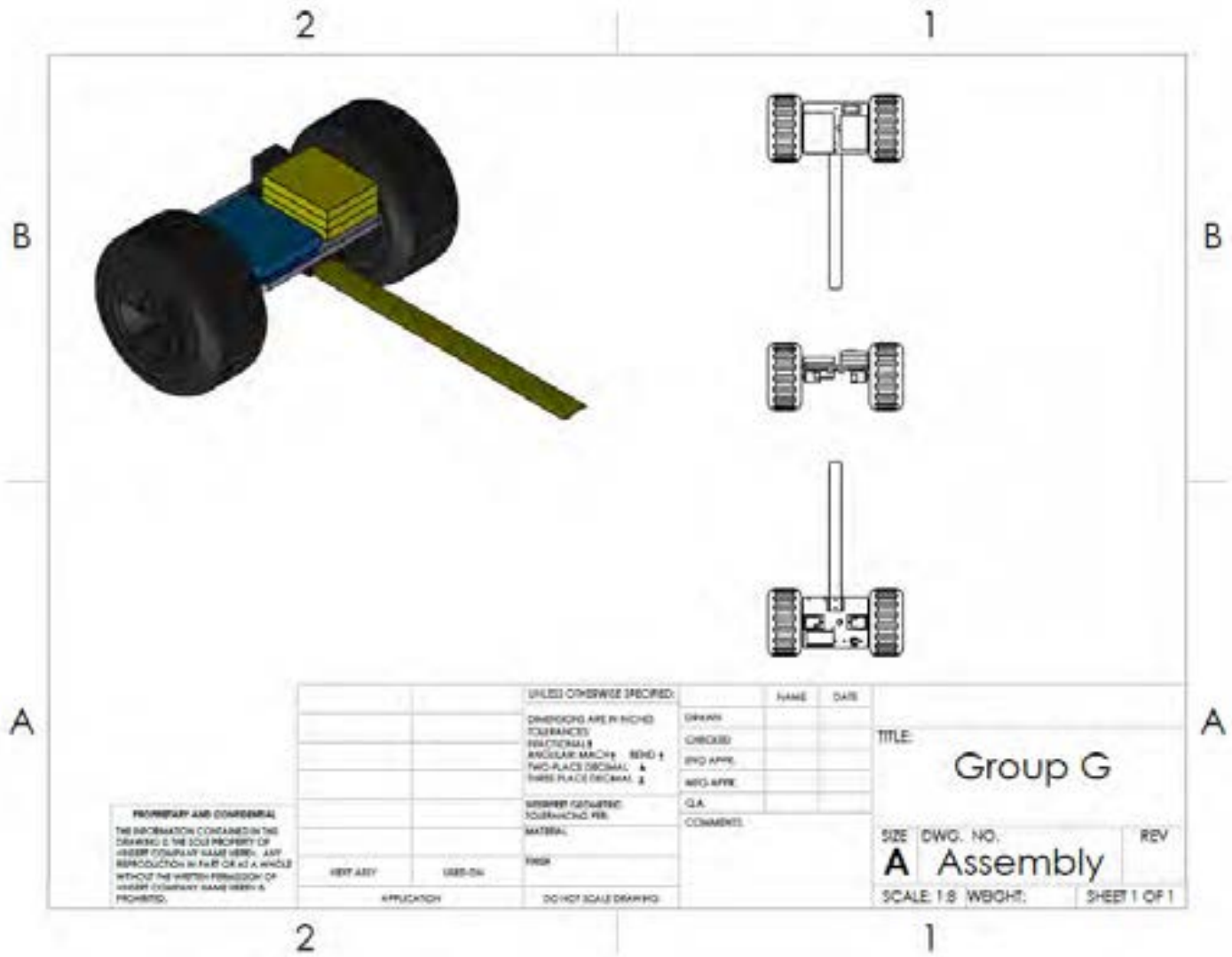

Figure 36: Working Prototype CAD Assembly





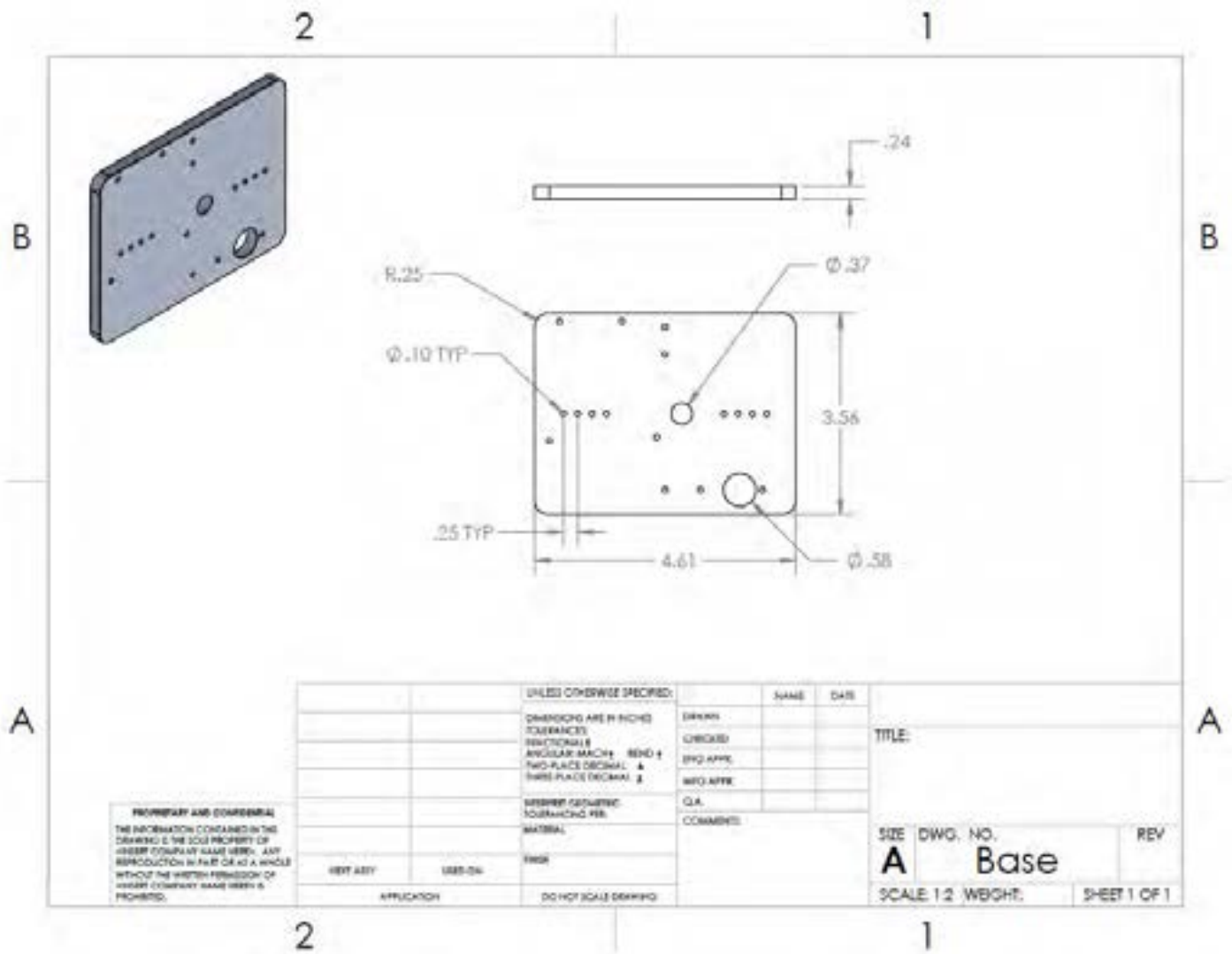

Figure 38: Custom Base Plate





## **BIBLIOGRAPHY**

Adafruit Industries. "Mini Round Robot Chassis Kit - 2WD with DC Motors." Adafruit Industries Blog RSS, [www.adafruit.com/product/3216](http://www.adafruit.com/product/3216).

Adafruit Industries. "Adafruit METRO 328 - Arduino Compatible - with Headers." Adafruit Industries Blog RSS, 30 Mar. 2018, [www.adafruit.com/product/2488](http://www.adafruit.com/product/2488).

"ARLISS: A Rocket Launch for International Student Satellites." ARLISS Release, 2018, [www.arliss.org/](http://www.arliss.org/).

"Georgia Tech RescueBot." Georgia Tech RescueBot, Boeing, 2013, [singhose.marc.gatech.edu/rescuebot/Home.html](http://singhose.marc.gatech.edu/rescuebot/Home.html).

"The OG App-Enabled Ball." Sphero, 2018, [www.sphero.com/sphero](http://www.sphero.com/sphero).

"Trekbot Micro Robotic Racer." Coolest Gadgets, [www.coolest-gadgets.com/20101010/trekbot-micro-robotic-racer/](http://www.coolest-gadgets.com/20101010/trekbot-micro-robotic-racer/).