

Washington University in St. Louis

Washington University Open Scholarship

Mechanical Engineering Design Project Class

Mechanical Engineering & Materials Science

Fall 2015

Drone IV - The Final Chapter (Parasol Drone)

Noah M. Rosenblatt

Washington University in St Louis

Charles F. Warwick

Washington University in St Louis

Connor M. Furlong

Washington University in St Louis

Follow this and additional works at: <https://openscholarship.wustl.edu/mems411>



Part of the [Mechanical Engineering Commons](#)

Recommended Citation

Rosenblatt, Noah M.; Warwick, Charles F.; and Furlong, Connor M., "Drone IV - The Final Chapter (Parasol Drone)" (2015). *Mechanical Engineering Design Project Class*. 36.

<https://openscholarship.wustl.edu/mems411/36>

This Final Report is brought to you for free and open access by the Mechanical Engineering & Materials Science at Washington University Open Scholarship. It has been accepted for inclusion in Mechanical Engineering Design Project Class by an authorized administrator of Washington University Open Scholarship. For more information, please contact digital@wumail.wustl.edu.

Project to create a controllable, aerial drone capable of providing shading from UVA/UVB radiation. Consumers will be able to participate in outdoor activities (run, walk, play sports, etc.) while being protected from the sun. Shading mechanism can open and close midflight with the press of a button. No prior experience necessary for operation. Appropriate for all weather conditions except rain or snow (electronics of drone should not get wet). Adult supervision is necessary for children under the age of twelve.

MEMS 411 Design Report Title

Drone IV - The Final Chapter

Charlie Warwick, Noah
Rosenblatt and Connor
Furlong

Department of Mechanical Engineering and Materials Science
School of Engineering and Applied Science
Washington University in Saint Louis

Table of Contents

List of Figures	4
List of Tables	5
1 Introduction	6
1.1 Project problem statement	6
1.2 List of team members	6
2 Background Information Study	6
2.1 A short design brief description that defines and describes the design problem.....	6
2.2 Summary of relevant background information	6
3 Concept Design and Specification.....	8
3.1 User needs, metrics, and quantified needs equations.....	8
3.1.1 Record of the user needs interview.....	8
3.1.2 List of identified metrics	10
3.1.3 Table/list of quantified needs equations	11
3.2 Four (4) concept drawings.....	12
3.3 Concept selection process	16
3.3.1 Concept scoring (not screening).....	16
3.3.2 Preliminary analysis of each concept's physical feasibility	17
3.3.3 Final summary	18
3.4 Proposed performance measures for the design	19
3.5 Design constraints (include at least one example of each of the following)	120
3.5.1 Functional.....	20
3.5.2 Safety	20
3.5.3 Quality	20
3.5.4 Manufacturing.....	20
3.5.5 Timing	20
3.5.6 Economic.....	20
3.5.7 Ergonomic.....	21
3.5.8 Ecological	21
3.5.9 Aesthetic.....	21
3.5.10 Life cycle.....	21

3.5.11	Legal	21
4	Embodiment and fabrication plan	21
4.1	Embodiment drawing.....	21
4.2	Parts List	22
4.3	Draft detail drawings for each manufactured part.....	25
4.4	Description of the design rationale for the choice/size/shape of each part.....	30
4.5	Gantt chart.....	34
5	Engineering analysis.....	35
5.1	Engineering analysis proposal	35
5.1.1	A form, signed by your section instructor (insert your form here).....	35
5.2	Engineering analysis results.....	36
5.2.1	Motivation. Describe why/how the before analysis is the most important thing to study at this time. How does it facilitate carrying the project forward?	36
5.2.2	Summary statement of analysis done. Summarize, with some type of readable graphic, the engineering analysis done and the relevant engineering equations	36
5.2.3	Methodology. How, exactly, did you get the analysis done? Was any experimentation required? Did you have to build any type of test rig? Was computation used?.....	37
5.2.4	Results. What are the results of your analysis study? Do the results make sense?	37
5.2.5	Significance. How will the results influence the final prototype? What dimensions and material choices will be affected? This should be shown with some type of revised embodiment drawing. Ideally, you would show a “before/after” analysis pair of embodiment drawings.	38
5.2.6	Summary of code and standards and their influence. Similarly, summarize the relevant codes and standards identified and how they influence revision of the design.	40
5.3	Risk Assessment	41
5.3.1	Risk Identification	41
5.3.2	Risk Analysis.....	41
5.3.3	Risk Prioritization	41
6	Working prototype.....	43
6.1	A preliminary demonstration of the working prototype (this section may be left blank)..	43
6.2	A final demonstration of the working prototype (this section may be left blank).	43
6.3	At least two digital photographs showing the prototype	43
6.4	A short videoclip that shows the final prototype performing	44
6.5	At least four (4) additional digital photographs and their explanations	45
7	Design documentation.....	47

7.1 Final Drawings and Documentation 47

7.1.1 A set of engineering drawings that includes all CAD model files and all drawings derived from CAD models. See Appendix C for the CAD models..... 47

7.1.2 Sourcing instructions..... 52

7.2 Final Presentation 53

7.2.1 A live presentation in front of the entire class and the instructors (this section may be left blank) 53

7.2.2 A link to a video clip version of 1..... 53

7.3 Teardown..... 53

8 Discussion 54

8.1 Using the final prototype produced to obtain values for metrics, evaluate the quantified needs equations for the design. How well were the needs met? Discuss the result..... 54

8.2 Discuss any significant parts sourcing issues? Did it make sense to scrounge parts? Did any vendor have an unreasonably long part delivery time? What would be your recommendations for future projects?..... 55

8.3 Discuss the overall experience:..... 55

8.3.1 Was the project more of less difficult than you had expected? 55

8.3.2 Does your final project result align with the project description? 56

8.3.3 Did your team function well as a group?..... 56

8.3.4 Were your team member’s skills complementary?..... 56

8.3.5 Did your team share the workload equally?..... 56

8.3.6 Was any needed skill missing from the group?..... 57

8.3.7 Did you have to consult with your customer during the process, or did you work to the original design brief? 57

8.3.8 Did the design brief (as provided by the customer) seem to change during the process? 57

8.3.9 Has the project enhanced your design skills? 57

8.3.10 Would you now feel more comfortable accepting a design project assignment at a job? 57

8.3.11 Are there projects that you would attempt now that you would not attempt before?58

9 Appendix A - Parts List 59

10 Appendix B - Bill of Materials 60

11 Appendix C - CAD Models 62

12 Annotated Bibliography (limited to 150 words per entry) 63

Comment [CW1]:

Comment [CW2]: Table of contents is accurate up to section 4.3 (page 25)

List of Figures

Figure 3.2.1: Concept #1- The Window Shade Drone.....	13
Figure 3.2.2: Concept #2- The Sombrero Drone.....	14
Figure 3.2.3: Concept #3- The Umbrella-Legged Drone.....	15
Figure 3.2.4: Concept #4- The Tennis Racquet Drone.....	16
Figure 4.1.1: Parasol Drone Embodiment Drawing.....	22
Figure 4.3.1: Design for Top Plate of Shading Mechanism.....	26
Figure 4.3.2: Design for Base Plate of Shading Mechanism.....	27
Figure 4.3.3: Design for Support Rods of Shading Mechanism.....	28
Figure 4.3.4: Assembly for Frame of Shading Mechanism.....	29
Figure 5.2.1: Original Design for Parasol Drone.....	39
Figure 5.2.2: Final Design for Parasol Drone.....	39
Figure 5.2.3: Final Prototype of Parasol Drone.....	40
Figure 6.3.1: Full view of the initial drone prototype, without propellers or parasol apparatus.....	43
Figure 6.3.2: Full view of the final drone prototype with slack parasol apparatus.....	44
Figure 6.5.2: The Naza Lite flight controller and LED module.....	45
Figure 6.5.3: Naza Lite power supply positioned on the body of the drone.....	45
Figure 6.5.4 The Spektrum transmitter used to pilot the drone.....	45
Figure 6.5.5: Spektrum receiver positioned on the body of the drone.....	45
Figure 6.5.6: The 2200 mAh lithium ion battery used to power the drone.....	46
Figure 7.1.1: Original Motor Housing Concept.....	49
Figure 7.1.2: Original Motor Housing Shaft Extension.....	50
Figure 7.1.3: Original Motor Housing Assembly.....	51
Figure 7.1.4: Landing Support Legs.....	52

List of Tables

Table 3.1.1: User Needs Interview.....9

Table 3.1.2: Metrics and Associated Needs.....11

Table 3.1.3: Quantified Needs Equations.....12

Table 3.3.1: Concept Scoring for All 4 Drone Concepts.....17

Table 4.2.1: Parts List.....23

Table 4.2.2: Materials List.....25

Table 4.5.1: Gantt Chart.....34

Table 8.1.1: Scoring of Prototype by Category.....54

Table 8.1.2: Actual Concept Scoring.....55

1 Introduction

1.1 Project problem statement

The purpose of this design project is to produce a drone with sun-shading capabilities. This “parasol drone” is tasked to fly above the user, providing them relief from the harsh rays of the sun as needed. The finished product should cost no more than \$500 and be suitable for all potential users. A slim and sleek design is preferable, with a shading mechanism capable of deployment mid-flight with little to no setup required. Additionally, full coverage of the user (to scale) while maintaining a lightweight build is desirable, as well as enough speed to be able to keep up with a user at a jogging pace. Some additional features may include functional lighting or a collapsible frame.

1.2 List of team members

The team members for this project were Charles Warwick, Noah Rosenblatt and Connor Furlong.

2 Background Information Study

2.1 Design Problem

Original Design Brief: Design and build a flying drone that can capture images or video of the WashU campus. Safety first!

Final Design Brief: Design and build a flying drone capable of providing sun protection.

2.2 Relevant Background Information

DJI F450 Camera Positioning Kit

Initially, our design concept was to build a UAV (drone) that could take aerial photographs and video footage of Washington University's campus. In order to achieve quality images and videos that could be used in the school's publications, it would be desirable to avoid having any propellers or arms visible in the footage. This camera positioning kit for the DJI F450 (the drone body kit that our group used) moves the camera out from the body of the drone, keeping the image clean and professional. One element from this kit that we did incorporate into our final prototype were the legs that kept the camera off the ground during takeoff and landing. The pulley system on our parasol drone was fragile and tangled easily, so we decided to machine legs to create more ground clearance.

US Patent 2010022149 A1

While this patent was not specifically for a drone, it was relevant to our goal of creating a UV protective parasol. The patent describes a flexible woven fabric panel with less than 1% transmissibility to UVA/UVB radiation that would be useful in the manufacture of umbrellas, among many other potential uses. We used a two-layered curtain fabric very similar to those described in this patent to create the parasol portion of our drone.

Add-A-Motor 31243 Remote Motorized Umbrella Controller

This product, a remote-controlled motorized pulley intended to open an outdoor umbrella, was almost identical to the design of our servo-based pulley system to open the drone's parasol. We liked this concept because it could be controlled remotely, so the drone's parasol could be opened while it was already in flight.

US Patent 20150129711 A1

This patent was reviewed for its innovative rotor and propeller unit, of which the fast mounting propellers were of interest. This represented an interesting look into how our prototype might be made more easily storable while requiring minimal setup.

US Patent 20120241555 A1

This patent provided insight into alternative designs for the drone's support blocks. However, we did not end up using this idea because we decided, with Professor Jakiela's guidance, to forgo doing a complete design and build and to instead order a modifiable drone kit.

US Patent 20090008048 A1

This patent for a flexible protective cover was useful in establishing how we wanted to implement our shading mechanism. It gave us some new ideas and a different perspective on how to approach the problem.

3 Concept Design and Specification

3.1 User Needs, Metrics, and Quantified Needs Equations.

3.1.1 User Needs Interview

Customer Data: Umbrella Drone			
Customer: Professor Mark Jakiela			
Address: Washington University in St. Louis		Date: 13 September 2015	
Question	Customer Statement	Interpreted Need	Importance
What size should this be?	Diameter between Frisbee and 1 m	Furthest extent from center between 20 cm and 1 m	4
Would you need UV protection?	Of course	Must provide UV protection for head	4
What does the battery life need to be?	At least 1 day	Must fly for at least 1 day without recharging, assuming average use	3
How high above the head must the drone fly?	~1 m	Must be able to fly at least 9'6"	4
How light must it be to not cause injury if accidental fall?	Just have injury not possible	Must be light enough to not cause injury if falling from above	5

Would you want to stay dry while walking?	Obviously	Don't let rain hit user	5
Would you need it to work in moderate wind?	Yes please	Does not tilt over or lose course in moderate wind	4
What other capabilities would you like?	Get out of car without getting wet	Can pull out of car and fly up prior to getting person getting out of car	2
	Ability to change diameter of coverage	Expand or contract to desired diameter	2
	Can light up path	Lights on bottom	3

Table 3.1.1: User Needs Interview

3.1.2 List of identified metrics

Need Number	Need	Importance
1	Drone has great enough diameter to fully cover user (to scale)	3
2	Angle of wings is at least enough for water drops to drip down	5
3	Drone can fly continuously to walk from corner to corner of WUSTL without landing	4
4	Small enough size to fit through car door	4
5	Center controller light enough not to cause serious injury from fall from hovering height	5
6	Whole drone must be light enough and not awkward to carry easily	3
7	Drone can fly fast enough for human running	2
8	Powerful enough to perform function in rain and/or wind	5
9	Drone must generate enough lift to stay above head	5
10	Easy enough to use for minimum age	3
11	Drone can light up path ahead or provide reading light	3
12	Must cost within the budget	5

Table 3.1.2: Metrics and Associated Needs

3.1.3 Table of quantified needs equations

Need#	Need	Metric												Need Happiness	Importance Weight (all entries should add up to 1)	Total Happiness Value		
		1	2	3	4	5	6	7	8	9	10	11	12					
Example Template																		
1	Drone has great enough diameter to fully cover user	0.8								0.2							0.06383	
2	Angle of wings is at least enough for water drops to drip down		0.65							0.35							0.106383	
3	Drone can fly continuously to walk corner to corner of WUSTL without landing			0.6													0.085106	
4	Small enough size to fit through car door				0.5												0.085106	
5	Center controller light enough not to cause serious injury from fall from hovering height					0.8				0.2							0.106383	
6	Whole drone must be light enough and not awkward to carry easily	0.15								0.3							0.06383	
7	Drone can fly fast enough for human running			0.2						0.65							0.042553	
8	Powerful enough to perform function in rain and/or wind				0.15					0.15							0.106383	
9	Drone must generate enough lift to stay above head								0.05								0.106383	
10	Easy enough to use for minimum age									0.1							0.06383	
11	Drone can light up path ahead or provide heading light																0.06383	
12	Must cost within the budget								0.05								0.106383	
Units		In.	Degrees	Minutes	In. ³	lbF	lbF	ft/s	ft/s	ft/lb/s	Dimensional	Years	Lux	USD				
Best Value		30	25	120	12	2	4	15	500	0.6		6	50	0				
Worst Value		12	5	30	40	5	15	5	200	0.2		12	20	500				
Actual Value																		
Normalized Metric Happiness																		
												Total Happiness						
												Total Happiness	0.106383					

Table 3.1.3: Quantified Needs Equations

3.2 Concept Drawings

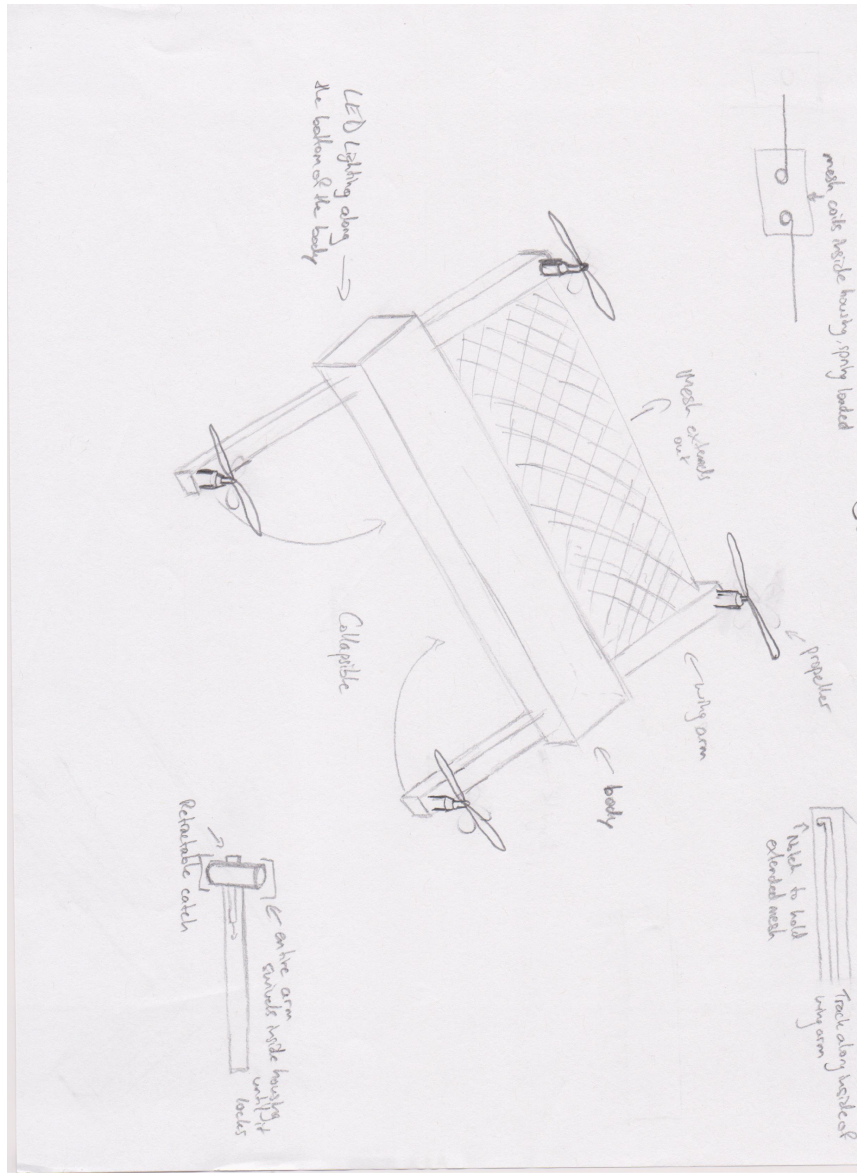

Figure 3.2.1: Concept #1- The Window Shade Drone

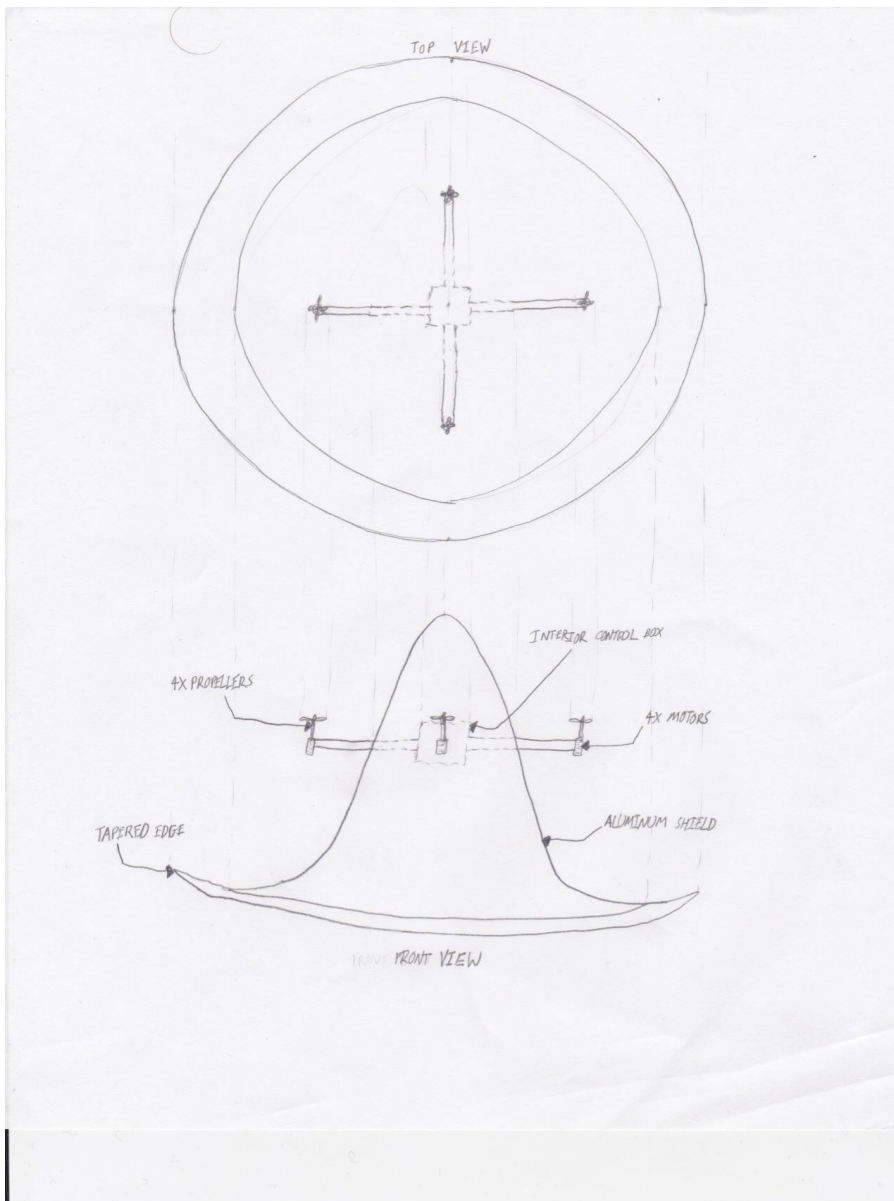

Figure 3.2.2: Concept #2- The Sombrero Drone

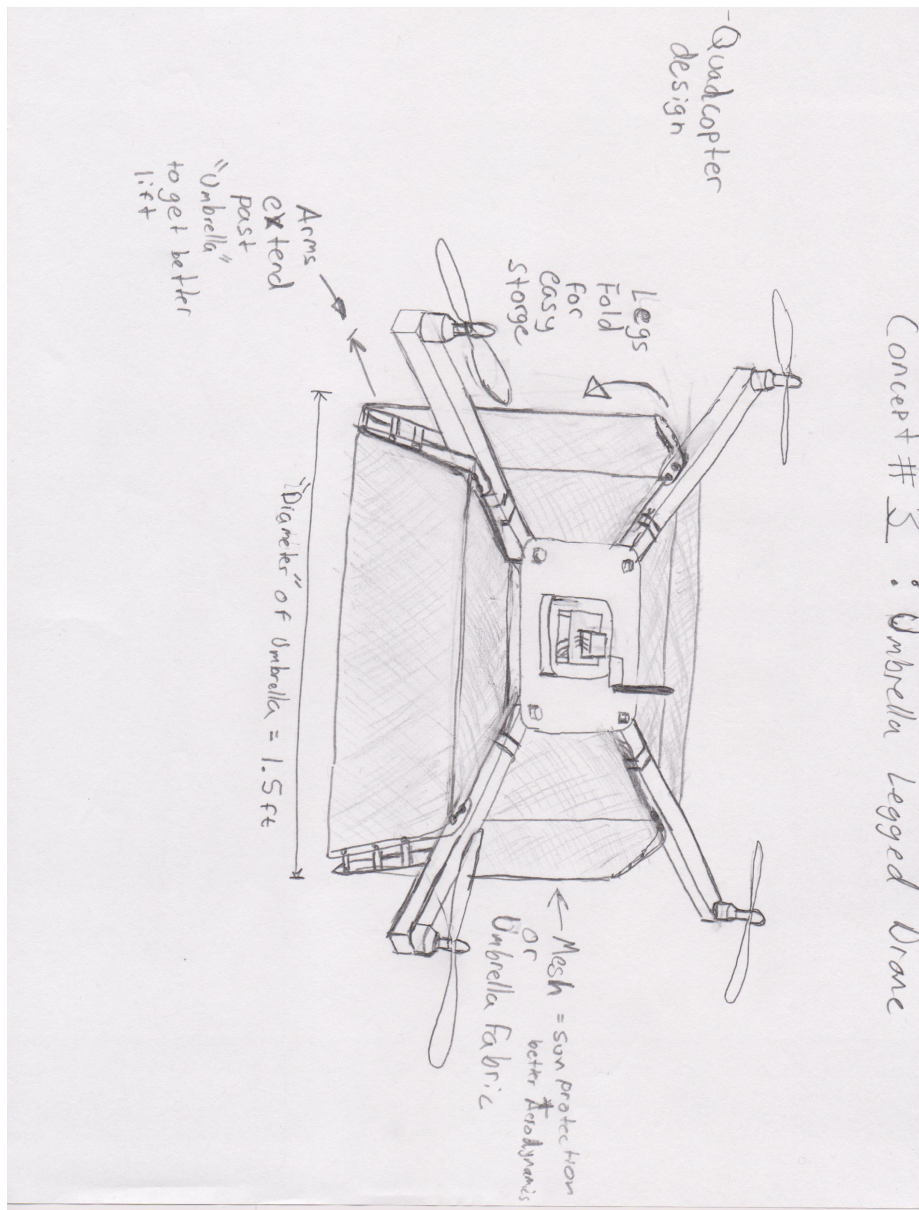

Figure 3.2.3: Concept #3- The Umbrella Legged Drone

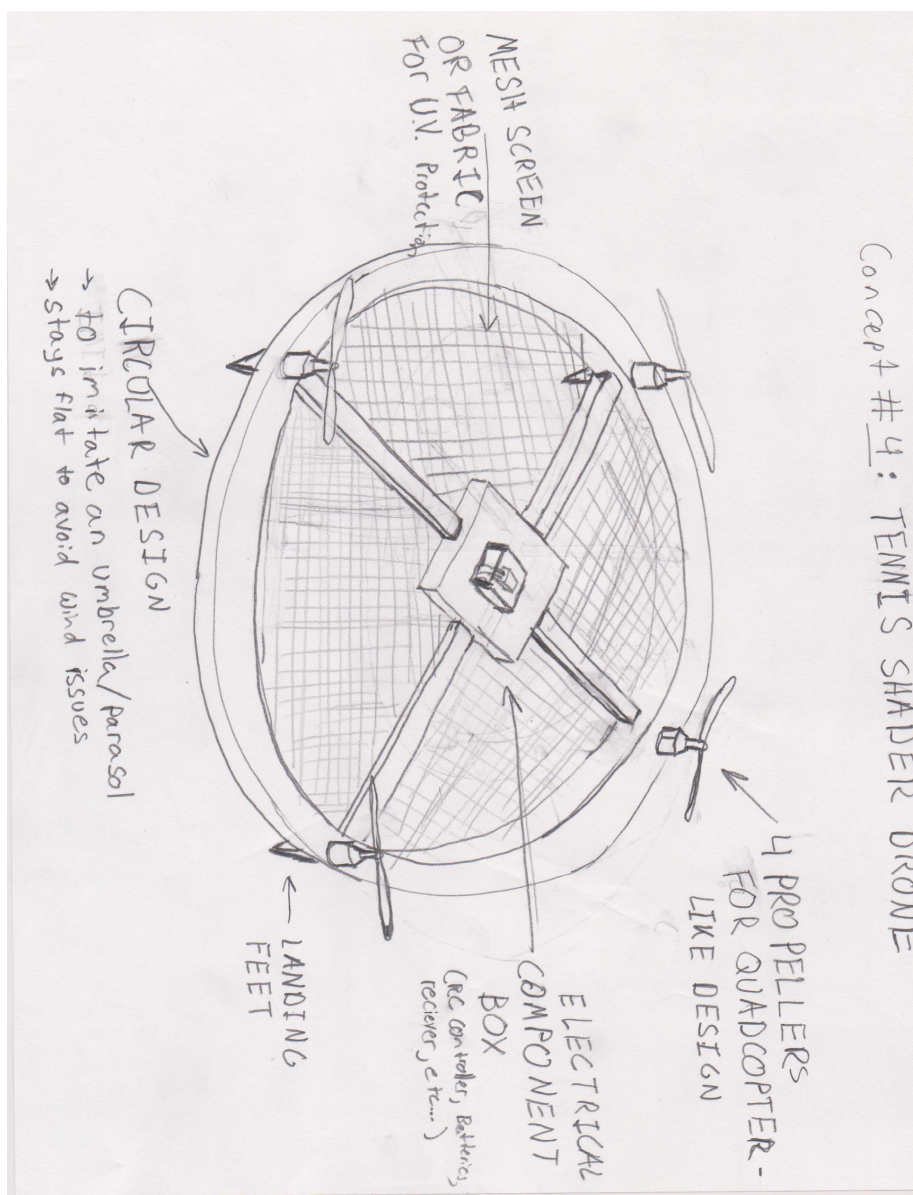

Figure 3.2.4: Concept #4- The Tennis Racquet Drone

3.3 Concept Selection Process

3.3.1 Concept scoring

Need	Metric	Metric												Total Happiness																
		1	2	3	4	5	6	7	8	9	10	11	12	Need Happiness 1	Need Happiness 2	Need Happiness 3	Need Happiness 4	Importance Weight (all entries should add up to 1)	Total Happiness Value 1	Total Happiness Value 2	Total Happiness Value 3	Total Happiness Value 4								
Example Template 1. Drone is great enough diameter to fly over 2. Angle of wings is at least enough for water drops 3. Drone can fly continuously to walk center to corner of W/ST1 without landing 4. Serial enough size to fit through car door 5. Center controller light enough not to cause serious burn from fall from hovering height 6. Whole drone must be light enough and not awkward to carry easily 7. Drone can fly fast enough for human running 8. Drone must generate enough lift to stay above ground for wind 9. Drone can fly fast enough for minimum age 10. Drone can light up path ahead or provide reading light 11. Max cost within the budget	Diameter of coverage	0.8	0.65	0.6	0.5	0.8	0.2	0.3	0.65	0.15	0.3	0.1	0.1	0.3	0.05	0.35	0.56277	0.18485	0.0825	0.25975	0.10633	0.06037	0.01576	0.00777	0.02731	0.4233				
	Angle of wings from horizontal																													
	Flight time on full charge																													
	Volume of drone																													
	Weight of center controller																													
	Total weight																													
	Max horizontal velocity																													
	Power generated by motors																													
	Lift coefficient																													
	Minimum age for use																													
	Illuminance																													
	Estimated cost of development																													
	Need Happiness 1	0.89833	0.825	0.525	0.58333	0.68333	0.04574	0.05266	0.03511	0.07234																				
	Need Happiness 2	0.12625	-0.60625	0.70625	-0.075	0.10633	0.13431	-0.04448	0.07533	-0.00798																				
	Need Happiness 3																													
	Need Happiness 4																													
	Importance Weight (all entries should add up to 1)																													
	Total Happiness Value 1																													
	Total Happiness Value 2																													
	Total Happiness Value 3																													
	Total Happiness Value 4																													

Table 3.3.1: Concept Scoring for All 4 Drone Concepts

3.3.2 Preliminary Analysis of Each Concept's Physical Feasibility

Concept #1: Window Shade Drone

The design of the Window Shade Drone is relatively simple, and incorporates important collapsibility and sun protection features. The collapsible feature would require little effort from the user, only to extend the arms and pull out the mesh screen for use. Undoing that process would allow the user to stow away the drone. The use of a catch to lock the mesh in place makes the matter of extending and retracting the screen very straightforward, while the arms would have a hinge along the side to be able to collapse them into the body. The design may encounter some issues with turbulence and heavy wind, as the current shape is not very aerodynamic. The open sides of the body while in operation may also pose a problem with the elements, however, the seriousness of this issue is unclear at this time. The general simplicity of the design makes the Window Shade Drone a strong candidate, as it would be reasonably easy to construct and does not pose too many concerns for flight or assembly failure.

Concept #2: Sombrero Drone

The design of Concept 2 demonstrates a drone composed of a concentrated interior control box, surrounded by a large but thin aluminum shield. This shield is shaped like a sombrero hat suspended with its widest dimension facing the ground. Aluminum was chosen for its relatively low density and its easy malleability into unusual shapes. The shield contains four holes for the propeller shafts to feed through. Using a quadcopter design, the perpendicular propellers provide lift for the drone while remaining rigid within the structure. The bottom of the shield is tapered at an upward angle so as to drastically increase the lift coefficient necessary for sustained flight. This could create the problem that rainwater would gather on top of the shield, weighing down the drone. The shield's radially symmetric design would allow for balanced flight. A potential problem is that once the drone tilts slightly from wind, it would be difficult to regain balance due to the shield's odd shape. Also, despite aluminum's low density compared to various steels, the drone would still be overly heavy because of the overall size of the aluminum sheet in use. Without protective barriers, the propellers would get wet during rainstorms, although this may not be an issue. The Sombrero Drone has a simple design, yet it fails in ways that could be avoided if using our other designs.

Concept #3: Umbrella Legged Drone

Brainstorming concept designs has shown that the umbrella drone's biggest obstacle will be the positioning of the sunshade or umbrella fabric. The aerodynamics of this project will be difficult to say the least due to the large amount of surface area the umbrella will have. This surface will only make it more difficult to fly in the wind let alone fly in the rain. Still, the umbrella legged drone will give the best positioning of the fabric in terms of lift. With the umbrella attached to the landing feet

of the drone, it allows the propellers to be above and extend past the fabric panels that are below them. This should help to make the umbrella more of an addition to an already working product rather than designing the drone around the sunshade or umbrella. This design pulls influences from the traditional quadcopter design and from traditional multi-angled umbrellas. The major issue with this design would be quick and easy storage of the drone. The legs fold into the drone like an umbrella, but the four arms of the quadcopter make it difficult to store in a car. So, to improve storage the legs or “umbrella” part of the drone would be detachable. Most of the components could be stored under the main square body, but there may be a need for an additional casing for the components that are on top of the drone. One of the good things about this drone is that it would remain lightweight so as to not injure the user. Its major down side is storage, and it would not fulfill the “getting out of the car without getting wet” user need. It would remain lightweight and would definitely keep the user comfortably shaded.

Concept #4: Tennis Racquet Drone

Concept 4 was designed to imitate the circular shape of a parasol or umbrella. The outer ring of low weight, 3D printed plastic gives a horizontal buffer to wind. This design is the only concept to completely protect the fabric/mesh liner that acts as the sunshade, or umbrella. Hopefully this will allow for good movement in windy conditions. Originally this concept had only three propellers but after considering the added weight from the outer ring we decided to go with a quadcopter design. The major issue this design presents is that there are no collapsible sections, which will make it difficult to get it out of an automobile. Designing a collapsible system for the ring will also add weight to the body of the drone and either make it difficult to get off the ground or slower than is needed to keep up with a runner. The tennis racquet design has better protection from sun, but has numerous aerodynamic and storage issues.

3.3.3 Final summary

WINNER: Concept 1 - Window Shade Design

Based on this preliminary analysis, Concept 1 seems to be the clear winner in terms of best design. It does not suffer from obvious problems to the same degree as the other three concepts. It is more aerodynamic and easier to construct than Concept 2. It is significantly more storable than Concept 3. It is much lighter than Concept 4. Overall, the drone should be able to sustain enough lift to remain in flight while fully covering the user from the elements. It is nicely adjustable for various user needs, and can collapse to a fraction of its size for purposes such as transportation in a car or bag. The design is easy to manufacture, and is estimated to cost the least of all the concepts, falling well within the \$500 budget. The minimum age of use would be relatively low. In addition, Concept 3 allows the easiest mounting of LEDs for path illumination because of its long and flat center console. Above all else, the design adequately performs the required flight functions along with the user while shielding the user from sun and rain. As supported by the esteemed Jakiela Happiness Equations, Concept 1 is chosen as the winning design.

3.4 Proposed Performance Measures

1. Drone has a diameter of at least 24"
2. Drone has an angle at the edge relative to horizontal of at least 5°
3. Drone can fly for at least 30 minutes on full charge
4. Drone has volume less than 40 in.³
5. Center controller of drone weighs less than or equal to 5 lbf
6. Drone in total weighs less than 15 lbf
7. Drone can fly at at least 10 ft/s
8. Motors can generate at least 200 ft-lbf/s
9. Drone has lift coefficient of at least 0.35
10. Drone can be used easily by at least a 6 year old
11. Drone can illuminate at least 20 lux of light
12. Drone costs less than or equal to \$500

3.5 Design Constraints

3.5.1 Functional

Overall geometry: The drone must shade a large enough area to be practical.

3.5.2 Safety

Operational: We must not falsely claim that the drone protects well against UVA/UVB radiation.

3.5.3 Quality

Quality control: The drone will be tested rigorously before being approved for use by consumers.

3.5.4 Manufacturing

Supplier quality: The manufacturer of the drone kit has been well researched and has proven to provide superior products.

3.5.5 Timing

Design schedule: The drone must completed and pass testing by the deadline.

3.5.6 Economic

Development cost: The overall product must be worth more than its cost to design and produce.

3.5.7 Ergonomic

Cybernetic: The controls must be simple and light enough for a child to be able to use easily.

3.5.8 Ecological

Material selection: The materials used must not contribute to global warming or ecological destruction.

3.5.9 Aesthetic

Future expectations: It must be the drone of the future, not the drone of the now.

3.5.10 Life cycle

Operation: The drone must be able to stably fly and block sun in its stated working environmental conditions over many years if used and maintained properly.

3.5.11 Legal

Intellectual property: The drone must not be sold if it breaks any patents, copyrights, or trademarks, which were all well researched.

4 Embodiment and Fabrication Plan

4.1 Embodiment Drawing

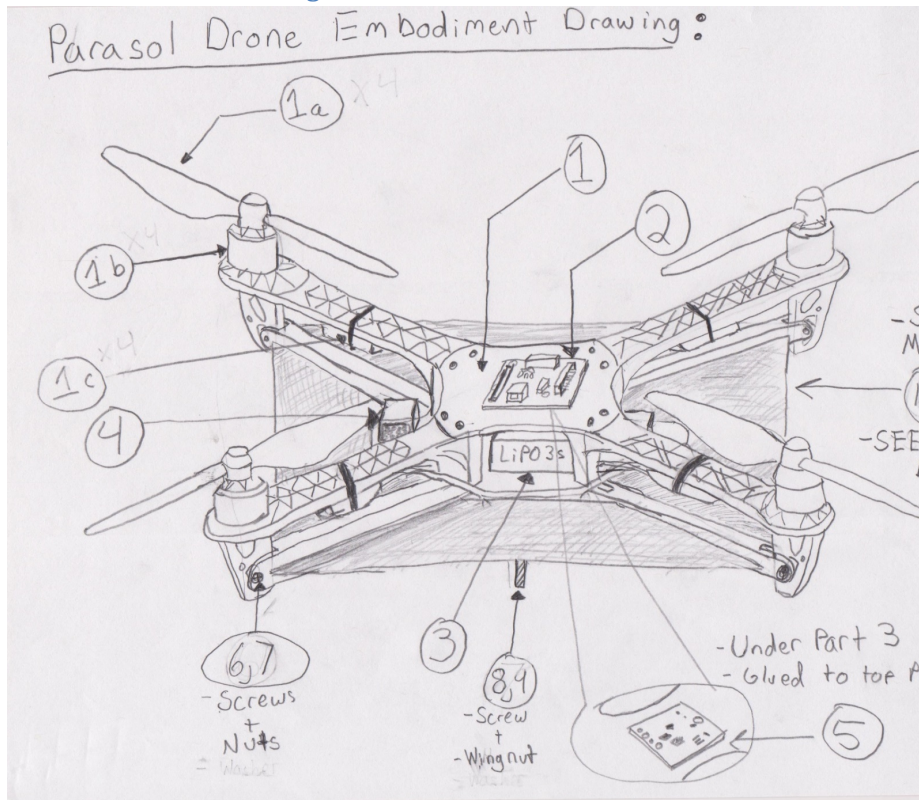

Figure 4.1.1: Parosol Drone Embodiment Drawing

4.2 Parts List

Part Number	Part
1	DJI Flamewheel F450 ARF Frame
1a	Z-Blade 9450 Propellers X4
1b	DJI 2312E Propulsion Motors X4
1c	420 LITE ESC 4s 20A – Speed controllers
2	Arduino Uno Rev 3
3	Turnigy 2200mAh 3s 25c Lipo Pack (Battery)
4	Naza LITE (Stabilizer)
5	Gyroscope Module 3-Axis L3G4200D
6	McMaster-Carr - 91290A045 (M2 Head Cap Screw, length 14mm)X8
7	McMaster Carr - 93625A101 (M2 Stainless Steel Lock nuts)X8
8	McMaster Carr - 91287A117 (M4-0.7 x25)
9	McMaster Carr - 94543A340 (M4-0.7)
10	Support Rod
11	Base Plate
12	Top Plate

Table 4.2.1: Parts List

Part	Use	Catalog Number/Website	Cost
DJI Flame Wheel F450 ARF Quadcopter Drone Kit w/Motors, ESC & Propellers. (1, 1a, 1b, 1c)	1X Main quadcopter Frame. 4X Propulsion Motors for lift. 4X Speed Controllers for variable rpm. 6X Quadcopter Blades- for lift force and two extra for replacement	http://www.aminhobbies.com/rc-drones/dji-flame-wheel-f450-arf-quadcopter-drone-kit-w-motors-esc-propellers-dji-fw450/p235232	\$190.00
Arduino Uno Rev 3	Flight Control, stabilization, and possible use for aerial deployment of the shading mechanism.	http://www.amazon.com/Arduino-A000066-Uno-Rev-3/dp/B008GRTSV6	\$15.90
Turnigy 2200mAh 3s 25c Li-Po Pack	Battery (power supply)	http://www.hobbyking.com/hobbyking/store/_8934_Turnigy_2200mAh_3S_25C_Lipo_Pack.html	\$9.99
Naza LITE	Stabilizing Gyro	http://www.hobbyking.com/hobbyking/store/_8934_Turnigy_2200mAh_3S_25C_Lipo_Pack.html	\$65.99
Gyroscope Module 3-Axis L3G4200D	Gyro to interact with the Arduino (Arduino package calls for this gyro)	https://www.parrallax.com/product/27911	\$29.99
M2 x .04 Head Cap Screw X8	Fastening the Support Rods to the Baseplate of the shading mechanism, and to the legs of the drone kit.	McMaster-Carr - 91290A045	\$6.82 /10

M2 x .04Stainless Steel Locknuts X8	Fastening the Support Rods to the Baseplate of the shading mechanism, and to the legs of the drone kit.	McMaster Carr - 93625A101	\$9.52 /100
M4 x .07 Stainless Steel Cap Screw X1	This screw is the main support rod that holds the shading mechanism together. It locks the support rods into a horizontal position.	McMaster Carr - 91287A117	\$6.20 /50
M4 x .07 Stainless Steel Wingnut X1	This wingnut was chosen because it will allow the user the ability to easily unscrew the bottom plate of the shading mechanism so the drone could fly without the shade. It also makes for easier storage.	McMaster Carr - 94543A340	\$9.66 /10
Support Rods X4	Arms that will extend to hold the shading fabric in place.	Washington University in St. Louis 3D Printing Lab	\$0.00
Base Plate X1	This Plate will be fabricated out of the 3D printing plastic, and will be used as the main connection of the 4 support rods.	Washington University in St. Louis 3D Printing Lab	\$0.00
Top Plate X1	This plate is used as an extra support plate due to the fact that the base of the drone kit is a thin piece of metal and may not be able to take the upward force of the support rods. Since the base of the drone is where much of the circuitry will be housed, we don't want that metal plate bending due to the weight of the shading mechanism.	Washington University in St. Louis 3D Printing Lab	\$0.00
Estimated Total Cost			\$345.00

Table 4.2.2: Materials List

*The extra gyro may not be needed for the Arduino to interface with the motors correctly but was added as a precaution. (cost reduction)

4.3 Draft detailed drawings for each manufactured part

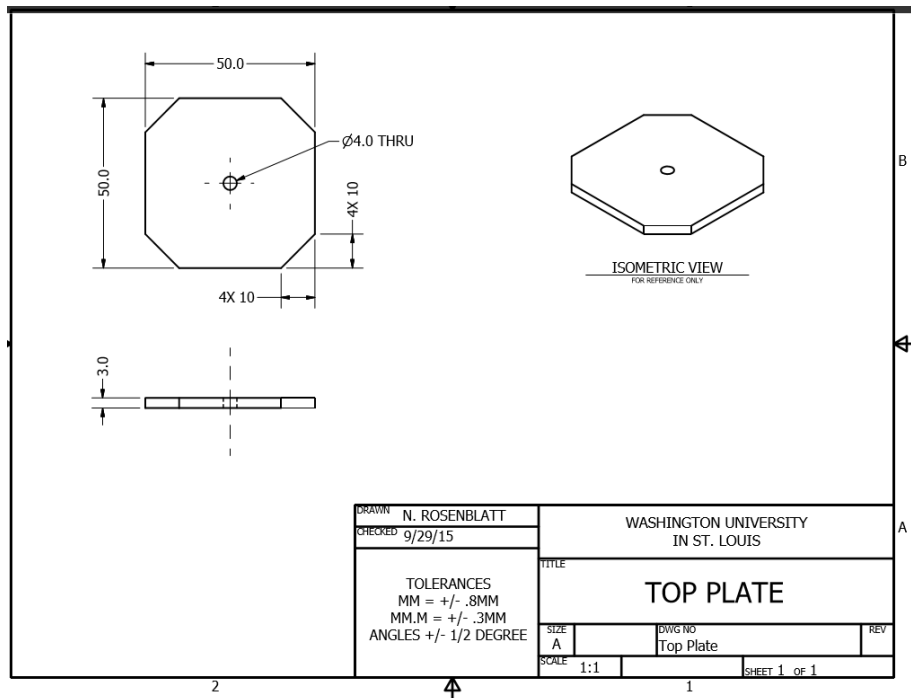
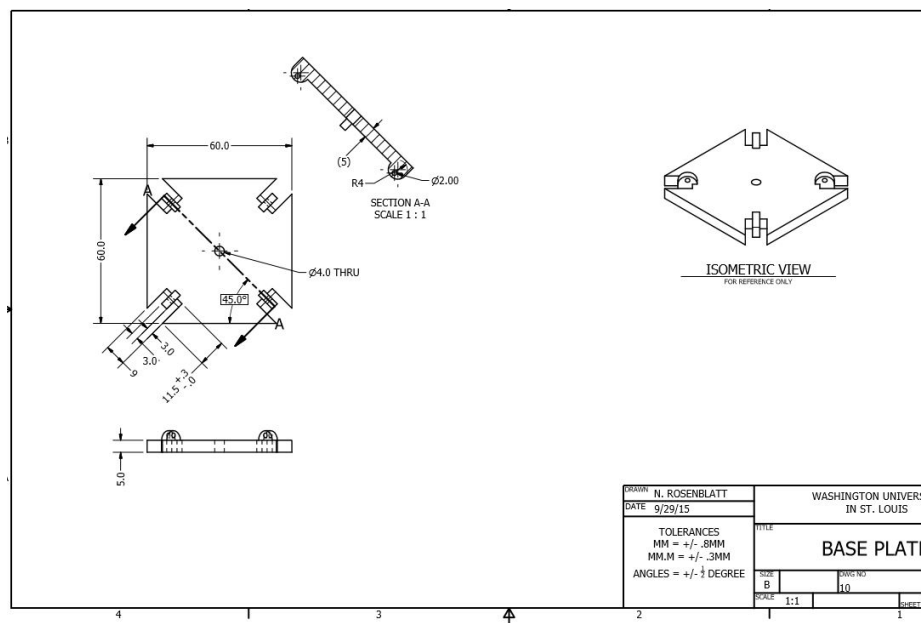
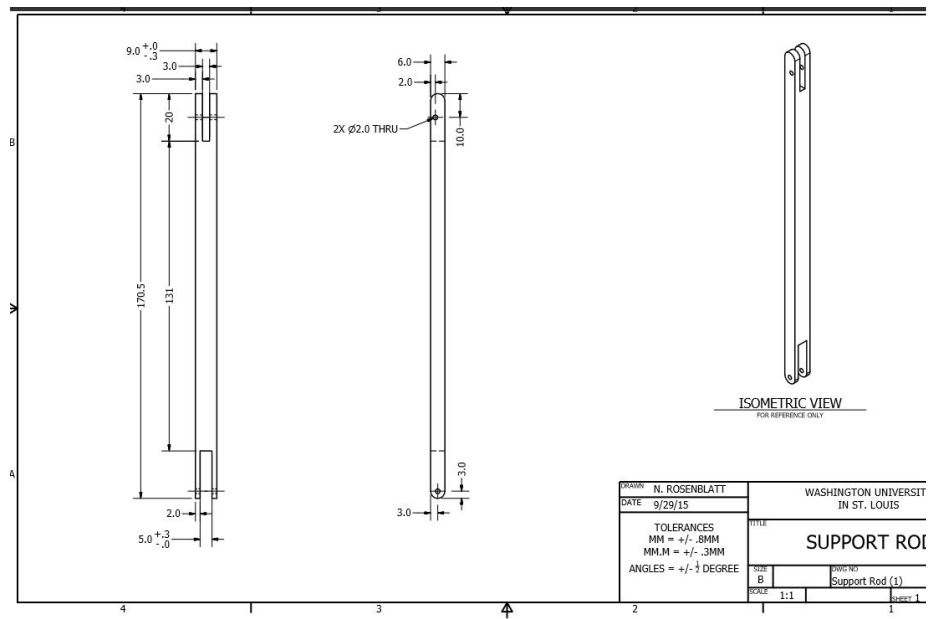

Figure 4.3.1: Design for Top Plate of Shading Mechanism*



Base Plate.pdf

Figure 4.3.2: Design for Base Plate of Shading Mechanism*



Support Rod (1).pdf

Figure 4.3.3: Design for Support Rods of Shading Mechanism*

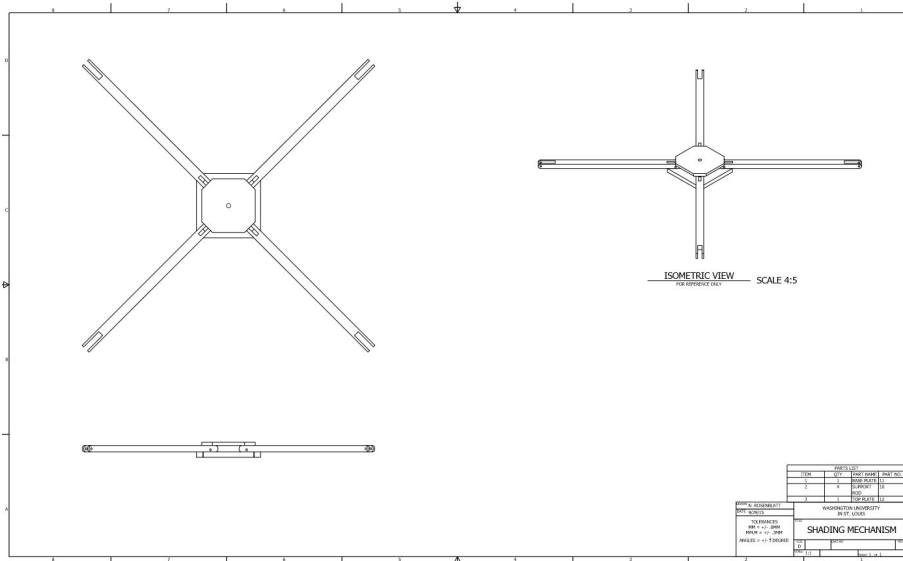

Shading Mechanism.pdf

Figure 4.3.4: Assembly for Frame of Shading Mechanism*

*These parts were not used in the final prototype

4.4 Description of the Design Rationale for the choice/size/shape of each part

Part 1: Drone Kit (Multicomponent)

The drone kit was chosen while keeping in mind that the project is being built to scale. There are no drones currently available that are of an adequate size to be able to fully offer sun protection for a person. With this in mind, the drone will have dimensions of 45cm by 45cm, and a body shape of an X, which allows for superior flight capabilities and provides an optimal connection with our shading mechanism. The main body will be the primary point of connection as it is the largest continuous portion of the drone and thus offers the most stability. The assembled height of the drone will be roughly 6cm, which generously allows for the addition of our shading mechanism without making the overall size too cumbersome. The drone provides a reasonable amount of power, 2.5 kW, which as calculated below is enough to carry the additional weight of the mechanism.

$$P_R \propto \frac{1}{[C_L^{\frac{3}{2}}/C_D]}$$

Where P_R is the Power Required, C_L is the Coefficient of Lift, and C_D is the Coefficient of Drag. The coefficients of lift and drag are both calculated using the following equations.

$$C_L = \frac{F_L}{qA}$$

Where F_L is the Lift Force, q is the Dynamic Fluid Pressure, and A is the Area.

$$C_D = \frac{2F_D}{\rho u^2 A}$$

Where F_D is the Drag Force, ρ is the Fluid density, u is Flow Speed, and A is the Area.

However these calculations can be avoided by assuming the drone to be a streamlined body which has approximated coefficients of 0.00065 and 0.04 for Lift and Drag respectively. Plugged into the equation for the Required Power as shown below results in a necessary power of 2.4 kW which is below our power output.

$$P_R = \frac{1}{[0.00065^2/0.04]} = 2413W$$

Part 2: Arduino Uno Rev 3

The Arduino chip was selected to be used in our design because of the glowing recommendations on its flexibility and ease to program. The chip will be receiving all the inputs to the drone and dispatching the appropriate output commands, such as controlling the power supplied to the motors at any given time. The chip is relatively inexpensive compared to the amount of value it will contribute, and its compact size will allow for ease of attachment to the drone. The chip will be centrally located on the body and the wiring will run along the drone frame as needed to reach the necessary components.

Part 3: Gyroscope Module

The Gyroscope Module was decided upon as a supplement to the Arduino chip and Naza-Lite as it provides an important input in the form of stabilizing data. The gyroscope will alert when there needs to be a correction made and thus provide the necessary input to achieve the correction, without which the drone would inevitably crash itself. The ability to stabilize is important for maintaining steady flight, but also since our drone will see consistent destabilizing interactions because of the tether pulling it along, it is a critical component.

Part 4: Naza-Lite

The Naza-Lite is a flight control system that works with the Arduino and Gyroscope in reading the stabilizing data and assisting with keeping the drone level in the desired preset plane. This is important as previously mentioned, because without this data the drone wouldn't make corrections to its motors to keep a level flight path and prevent crashing. The Naza-Lite is thus imperative for the successful flight of the drone. As with the

gyroscope, the compact size makes it desirable for use with the drone as it won't add undue weight and bulk, while being easily adaptable for our purposes.

Part 5: GT Power RC 2s/3s

The GT Power RC is another important part of the success of the drone, although not part of the drone build, it is a charger for the battery that will be powering the drone. It greatly simplifies the design for a power source that is permanent to the drone instead of having to take into account having the capability for changing batteries as needed. This allows for more freedom in the placement on the drone body as it doesn't need to be as openly accessible. The battery is to be located inside the body of the drone, easy to be recharged, but not apt for being changed on a regular basis, such as would be necessary between flights, and hence warrants the need for a charger.

Part 6: Shading Mechanism (Multicomponent)

The main considerations taken into account with the design of the shading mechanism were the ability to provide reasonable sun protection (to scale), and to be easily removable and storable. To this end the mechanism consists of 4 supporting rods (plastic), 2 plates (base –aluminum, top –plastic), and the UV protection fabric. The supporting rods are planned to be approximately 17.5 cm in length, barring any major design overhauls, and similarly the plates are approximately 6 cm by 6 cm. The base plate has slots cut into the corners and anchor points for the attachment of the rods. The slots allow the rods to be easily collapsible when not in use and detached from the top plate, which is permanently anchored to the drone. While in use the anchor points keep the rods rigid against the top plate, thus securely holding the fabric and providing the best possible sun protection while mitigating potential interferences from the wind.

The materials for the components were chosen based upon the intended function and the needed durability. At this time the base plate is aluminum for a higher level of durability while still allowing the mechanism to be light, and the top plate is plastic, however this is subject to change to be aluminum as well depending upon the strength of the drone which we do not currently know. This will be concretely decided upon at a later date when we have a better idea of the flexibility of the drone in this regard. The rods are made of plastic as this will provide an optimal balance of lightweight strength and stability. There will be a bending moment and stress on each of the rods which has been calculated below and taken into account in our material selection.

$$M = FL$$

Where M is the Moment, F is the Applied Force, and L is the Rod length.

Assuming that the applied force is column of air that the drone is dragging, first the volume of the column is calculated, treating it as a cylinder, followed by mass and lastly by the force, all as follows.

$$V = \pi r^2 h$$

Where V is the Volume, pi is a Constant, r is the Radius, and h is the Height.

$$m = \rho v$$

Where m is the Mass, ρ is the Density (1.225 kg/m³), and v is the Volume.

$$F = mg$$

Where F is the Force, m is the Mass, and g is the acceleration due to gravity (9.81m/s²)

Assuming the radius is the same as the length of a supporting rod, and the height is 9 ft. (converted to meters for the calculation), the calculations are shown below to the final answer of force 3.172N.

$$V = \pi(0.175)^2(2.7432) = 0.264m^3$$

$$m = 1.225(0.264) = 0.323kg$$

$$F = 0.323(9.81) = 3.172N$$

Using this force and end of the rod as the point for the bending, the moment on the rod is calculated as follows.

$$M = 3.172(0.172) = 0.546Nm$$

As far as we know at this point the plastic from the 3D printing should suffice to withstand this moment, but until we ascertain the full spec at a later date we can't be entirely sure.

4.5 Gantt chart



MEMS 411 Gantt
Chart.xlsx

Table 4.5.1: Gantt Chart

5 Engineering analysis

5.1 Engineering analysis proposal

5.1.1 A form, signed by your section instructor

ANALYSIS TASKS AGREEMENT

PROJECT: Drone IV - The Final Chapter (Umbrella Drone)

NAMES: Charlie Warwick  CTOR: Mary Malast

Noah Rosenblatt 

Connor Furlong 

The following engineering analysis tasks will be performed:

Fluid Analysis:

Analysis of flow over a streamline body will be performed on our drone's body. We are assuming the drone to be in the shape of an airfoil for simplicity. We can discuss other ways to represent the drones shape with our instructor. We are looking to find out if the lift from the four propellers will be enough to get the drone off the ground and maintain desired height with its shading mechanism deployed. We also will analyze if the drag on the drone from wind will be too much to keep the drone airborne. The analysis on lift will be done before the drone is built and tested, and the drag analysis will be done after the drone has been built. We will do it this way to see if the shading mechanism will need to be deployed in the air after takeoff. This way we can budget for an extra motor to help deploy the shade in the air.

Material Stress Analysis:

Stress analyses have already been completed for the individual parts being fabricated. We will conduct an overall material analysis for the complete assembly, identifying potential points of failure by examining the normal and shear stresses by means of axial strain, bending, and torsion. This will require material properties for each material under stress.

Electrical Analysis:

The feasibility of the electrical circuit has already been analyzed by the engineer who created the video series we are using as a rough guide for our circuitry. Each motor will be supplied with enough power. The circuit will be limited by resistors of precisely chosen resistance.

The work will be divided among the group members in the following way:

We plan to meet together to build and analyze the whole assembly. We do not feel it is practical to split up this section of the project because of the sheer complexity of analyzing turbulent flows. The material stress analysis is not too complicated, but will be completed in the same session(s).

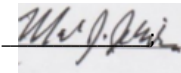
Instructor signature: 

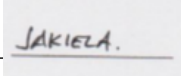
Print instructor name: 

5.2 Engineering analysis results

5.2.1 Motivation. Describe why/how the before analysis is the most important thing to study at this time. How does it facilitate carrying the project forward?

The initial design analysis is a crucial element to the completion of a successful project for if the design constraints and obvious challenges are not taken into account up front, they become much more difficult to solve as they arise and could lead to further challenges arising. With this in mind, the principle challenges to overcome are to build a drone that can fly successfully and implement an effective method of shading that doesn't interfere or restrict those flight capabilities. The initial prototype will seek to render a flight capable drone, providing a reliable basis for the creation of a shading mechanism suitable for the particular build and mitigating the amount of necessitated redesign work.

5.2.2 Summary statement of analysis done. Summarize, with some type of readable graphic, the engineering analysis done and the relevant engineering equations

As per the guidance of Professor Jakiela, we decided that it wouldn't be extremely practical to build a drone body from scratch, but neither would it best suit our needs to buy a ready to fly drone, so we ultimately settled on purchasing a drone kit that we could assemble ourselves and make adaptations too as needed. There was no concrete engineering analysis needed because of the direction given to us, however in purchasing our drone kit we did need to be wary of the size of the drone. The size of the drone has important implications to consider such as the maximum weight it can carry for flight, and erring on the side of caution we opted to go for a particularly robust model that would allow us a reasonable amount of leeway with the additional weight of our shading mechanism.

5.2.3 Methodology. How, exactly, did you get the analysis done? Was any experimentation required? Did you have to build any type of test rig? Was computation used?

The level of flexibility this approach allowed for enabled us a lot of freedom in our design work, and early prototypes focused on successfully getting the motors work and proving theoretical flight capability before moving on to integration of shading and flight. There were several unexpected pitfalls in the pursuit of establishing a flight worthy drone, primarily that which was incurred through the use of a borrowed receiver and remote that had hidden preprogramming, however, the drone body itself only underwent a single iteration. The shading mechanism on the other hand went through several renditions as the project continued to evolve, changing first to suit the nature of the drone body and then further as motor and housing complications arose. The shading mechanisms were developed concurrently with the drone and thus issues were detected early on in their design and dealt with accordingly, leading to the most effective and easily implemented final model.

5.2.4 Results. What are the results of your analysis study? Do the results make sense?

As previously mentioned we opted for a larger drone to accommodate a flexible approach to our design work, as well as minimize any risks unknown or otherwise with too small a drone such as resilience against moderate wind. We conceptualized several possible methods of shading implementation before narrowing in on our selected method. The way in which we approached our implementation did undergo several changes as deviations or issues came up. The utilization of a regular motor came with several housing problems from the fabrication to the attachment to the drone's frame, and even after that had all been dealt with the motor was too powerful for our purposes and we were unable to effectively reduce its speed to one more suitable for our purposes. In order to remedy this issue for the final prototype we switched to a servo motor that we altered for continuous full range of motion, providing us with the appropriate level of speed required.

The major analysis that was performed on the drone was whether or not the drone would be able to lift off the ground with the added weight of the original shading mechanism. With all of the basic drone components added of the weight of the drone came out to around 1050g, which was below the limit of 1600g that the drone kit manual said the drone could carry. With this in mind our team came to the realization that the added shading mechanism, with all the plastic arms, base, top plate, and long screw would be too heavy an option to pursue. To counter this blow to our design we met with the lead teaching assistant, Ethan Glassman, to try and come up with a viable alternative. He suggested that we use the preexisting holes in the legs of the drone arms (the legs are the portions of the drone kit arms that extend down below the motors) as a pulley mechanism. By running high strength fishing line

through these holes and tying the string to a motor shaft at the bottom of the drone, they could be attached to two opposite corners of a piece of shading fabric so that when the motor spun it would pull the two corners of the fabric to a horizontal taut position. The idea is demonstrated in the first section of the video demonstration of section 7.2.2.

This was the majority of the analysis that was done for the drone, because any parts that would have factors of safety that could be a concern were over compensated. The string for instance has a tensile strength of almost double what a 1/4 th of the servos torque capability is. The analysis for the capability of the string was performed by Connor Furlong, where he found that he stings would pull in four different directions, when they were taught, with equal force. This would divide the force from the moment of the motor if four. That was how we came up with the high strength fishing line to use for our shading mechanism.

5.2.5 Significance. How will the results influence the final prototype? What dimensions and material choices will be affected? This should be shown with some type of revised embodiment drawing. Ideally, you would show a “before/after” analysis pair of embodiment drawings.

The constant process of analysis and experimentation throughout the project saw some expected results as well as some that were more of a surprising, culminating in a final prototype that is significantly different from our initial concept sketches. The drone itself didn't suffer any changes in dimensioning or material throughout the course of the prototyping, however the shading mechanism, as mentioned, underwent several changes before reaching its final build. Our initial and final shading designs are pictured below in in Figures 5.2.1 and 5.2.2 respectively. As can be seen from the designs we went from a complete shading apparatus that would have added an excessive amount of weight to the drone, to a more simplistic and lightweight model that doesn't make use of its own frame.

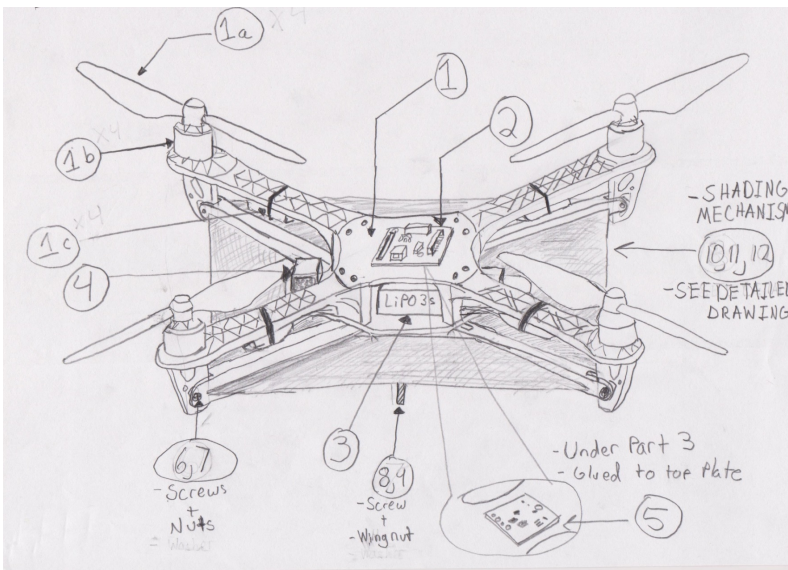

Figure 5.2.1: Original Design for Parasol Drone

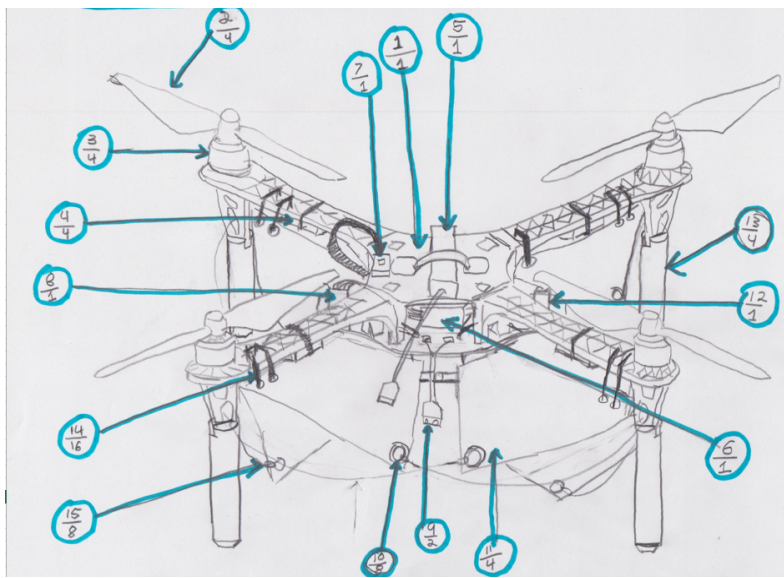

Figure 5.2.2: Final Design for Parasol Drone

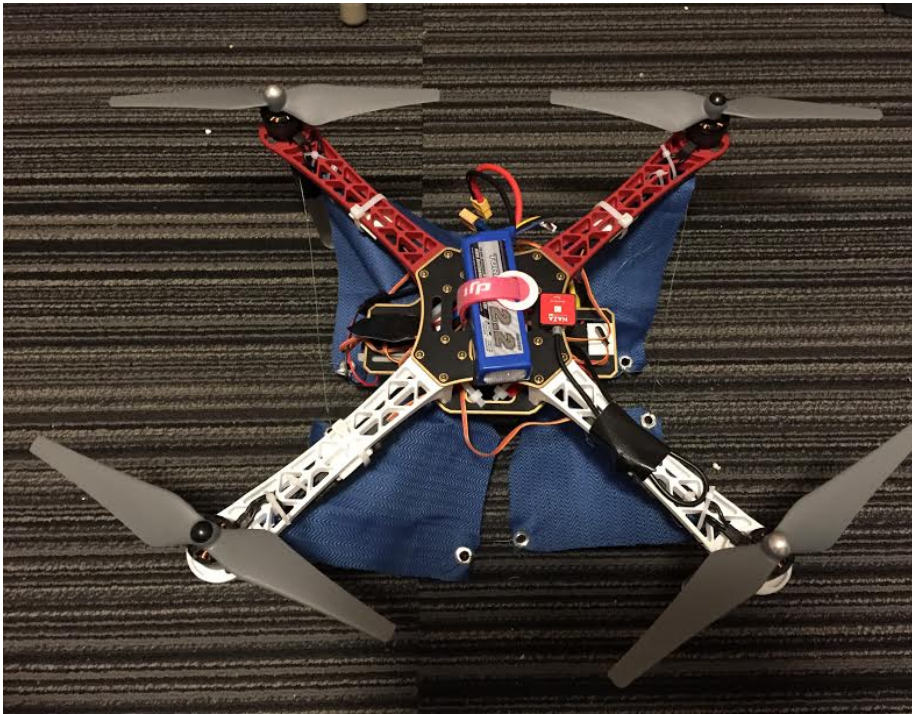

Figure 5.2.3: Final Prototype of Parasol Drone

5.2.6 Summary of codes and standards and their influence. Similarly, summarize the relevant codes and standards identified and how they influence revision of the design.

Our primary function of providing sun protection means that our prototype will never be flying excessively high as it needs to be within relatively close proximity of the user. However, just in case we examined the FAA's rules pertaining to drones, and according to the FAA Advisory Circular 91-57, model aircraft operators, applicable to drones, cannot fly their crafts more than 400 feet above the ground, must keep within visual range, and should not operate within 5 miles of an airport without first alerting the control tower. Our product isn't in danger of running afoul on any of these points, as the drone would need to be kept much closer than 400 ft. and as a result would always stay well within visual range at all times of operation. This product would expect to see use primarily in residential or park areas, both of which are not typically found within 5 miles of an airport and thus not a significant concern.

There is a general lack of code applicable to drones, as it largely is unregulated and the FAA doesn't implement new rules very frequently.

5.3 Risk Assessment

5.3.1 Risk Identification

With a limited budget, what if the wrong drone kit is purchased, one that does not function the way that is needed? Will the drone be able to protect itself in the case of midflight failure? Will the safety of the user ever be at risk? What if the project is too ambitious to complete within the timeframe? Will the benefits gained from the shading mechanism triumph over the time, cost, and effort put into the project? Will the shading mechanism create too much drag for the drone to fly properly?

5.3.2 Risk Analysis (This is based on your project engineering analysis. Tools include simulation, happiness equations, calculation by hand or with SolidWorks, MATLAB, etc.). Discuss risk as it pertains to your performance specification, cost, and schedule.

It is highly likely that a cheaper drone-kit will not function as desired. The motors, for example, may fail more easily. The drone likely will be able to protect itself in the case of a midflight failure because the proposed Naza flight controller supports a safe-mode. The user will be at risk until the prototype has undergone rigorous testing and tweaking. The Naza safe-mode does not prevent the drone from descending quickly. It is possible the project will not be completed within the timeframe, but the engineers on the project will work diligently and tirelessly to ensure that this does not happen. Given the pain the average person experiences from the sun on a hot day (in addition to UV radiation damage), it is highly expected that the drone will provide greater gains than losses. It is not probable that the shading mechanism will create too much drag for the drone to fly properly because the drone-kit to be purchased already flies significantly below its motors' max capacities.

5.3.3 Risk Prioritization (Write a short description of how your team prioritized risk for your project. Include any tables or diagrams that support your prioritization).

The prioritization of mitigating risk is as follows (from most to least priority):

1. User safety
2. Proper drone-kit purchased

3. Drag from shading mechanism
4. Drone protection from mid-flight failure
5. Net benefit of undertaking project
6. Ambition of project

Risk mitigation planning, implementation, and progress monitoring

This project is just a proof of concept, so the components of risk are not fully evaluated at each point in the development. User safety, despite being the most significant risk, is not given much attention because the overall budget is too small and the timeframe is too short to allow for the necessary rigorous testing. Before purchasing the drone-kit, vast research into various kits is necessary to ensure the drone will operate as desired. When the shading mechanism is attached, flight ability frequently will be tested. Any changes to the mechanism require more testing. Intentional midflight failure will be simulated to examine the drone's ability to protect itself. To roughly determine the net benefit of the project, expenditures will be monitored carefully, as will the smile of the project manager, Mark Jakiela, in response to our prototypes. If the ambition of the project is too great, the engineers will work overtime to achieve the goals.

6 Working prototype

- 6.1 A preliminary demonstration of the working prototype (this section may be left blank).
- 6.2 A final demonstration of the working prototype (this section may be left blank).
- 6.3 At least two digital photographs showing the prototype

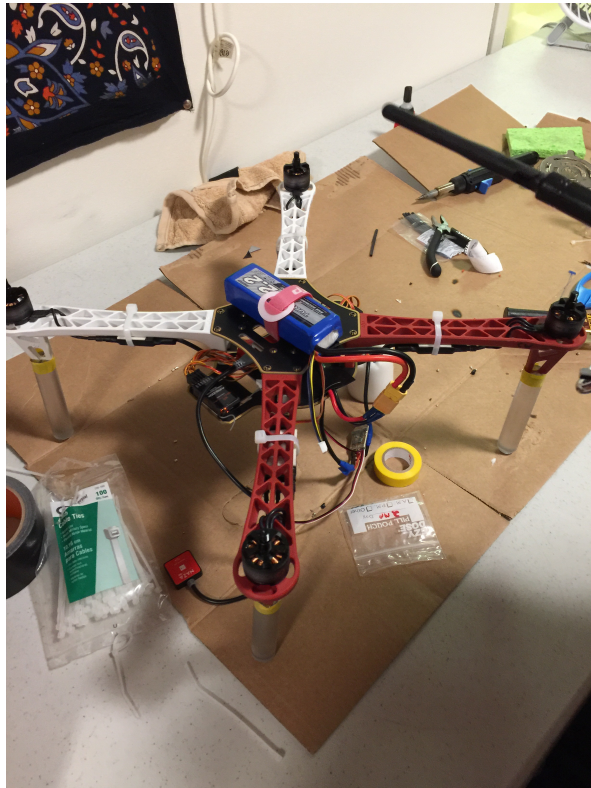

Figure 6.3.1: A full view of the initial drone prototype, without propellers or the parasol apparatus

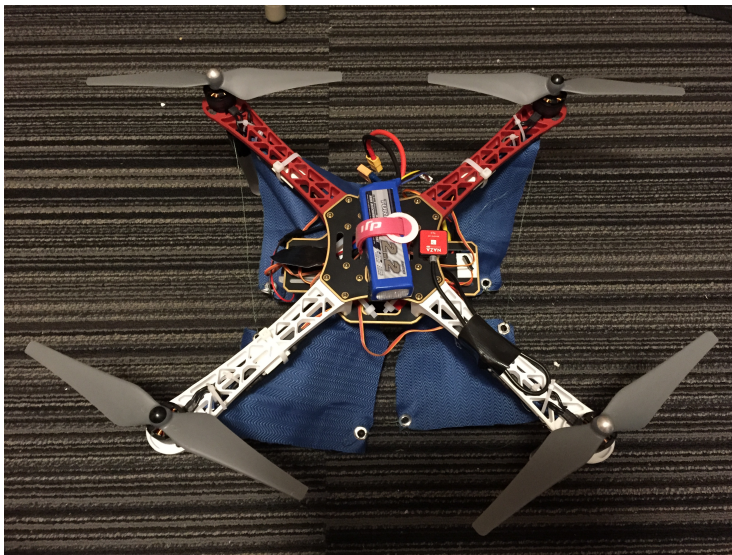

Figure 6.3.2: A full view of the final drone prototype with slack (unopened) parasol apparatus

6.4 A short videoclip that shows the final prototype performing

<https://www.youtube.com/watch?v=S-P6MpZ8zxo>

A short video of the parasol drone in flight.

6.5 At least four (4) additional digital photographs and their explanations

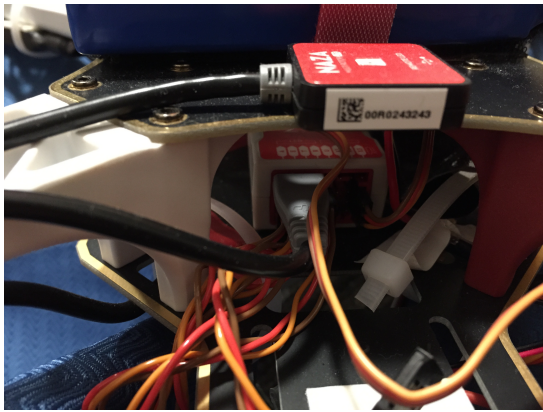

Figures 6.5.2 and 6.5.3: The Naza Lite flight controller and LED module (6.5.2) and its power supply (6.5.3)



Figures 6.5.4 and 6.5.5: The Spektrum transmitter (6.5.4) and receiver (6.5.5) used to pilot the drone

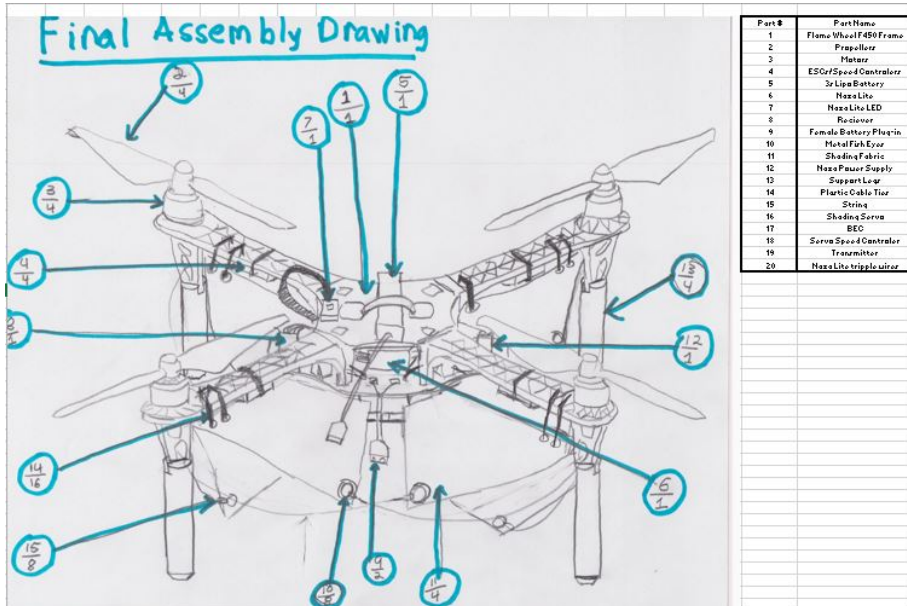

Figure 6.5.6: The 2200 mAh lithium ion battery used to power the drone

7 Design documentation

7.1 Final Drawings and Documentation

7.1.1 A set of engineering drawings that includes all CAD model files and all drawings derived from CAD models. See Appendix C for the CAD models.



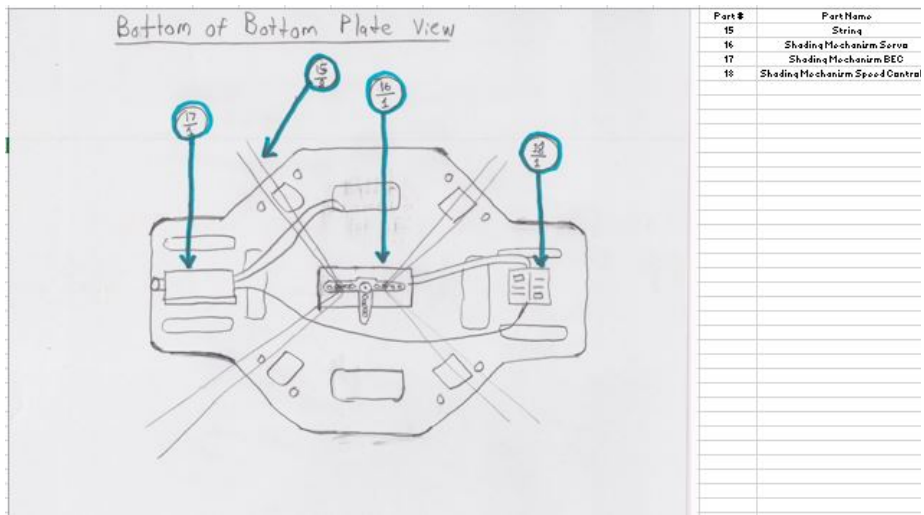



Final Assembly
Drawings.xlsx

(The images above are for the final assembly drawings for the prototype, and the bottom view of the final prototype. The Excel file link gives a closer look at the drawings.)

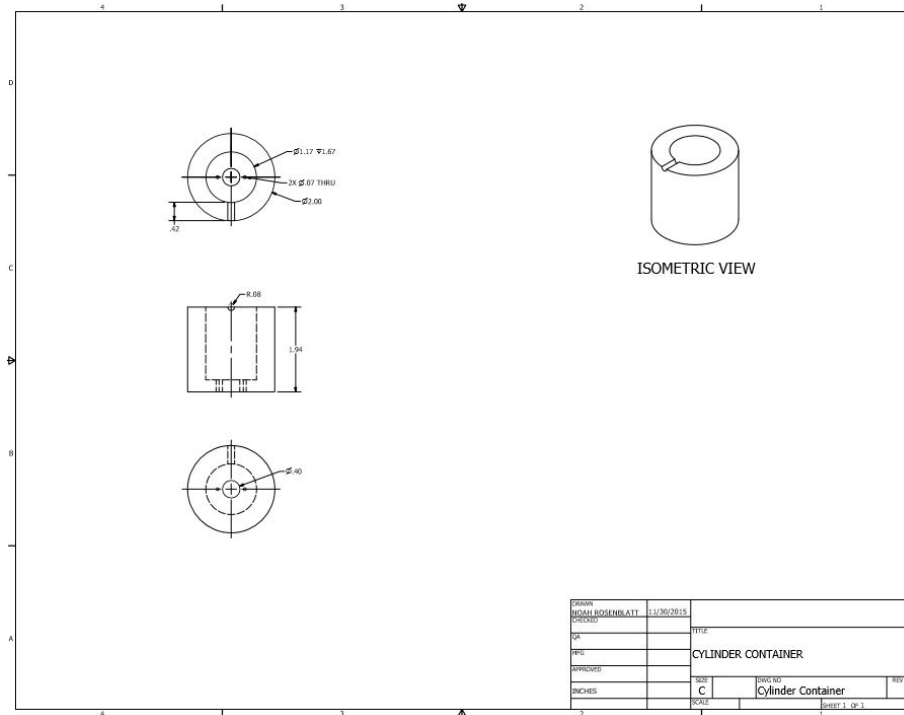
CAD Drawings: (* means not used in final prototype)



Cylinder Container.pdf

Figure 7.1.1: *Original Motor Housing Concept

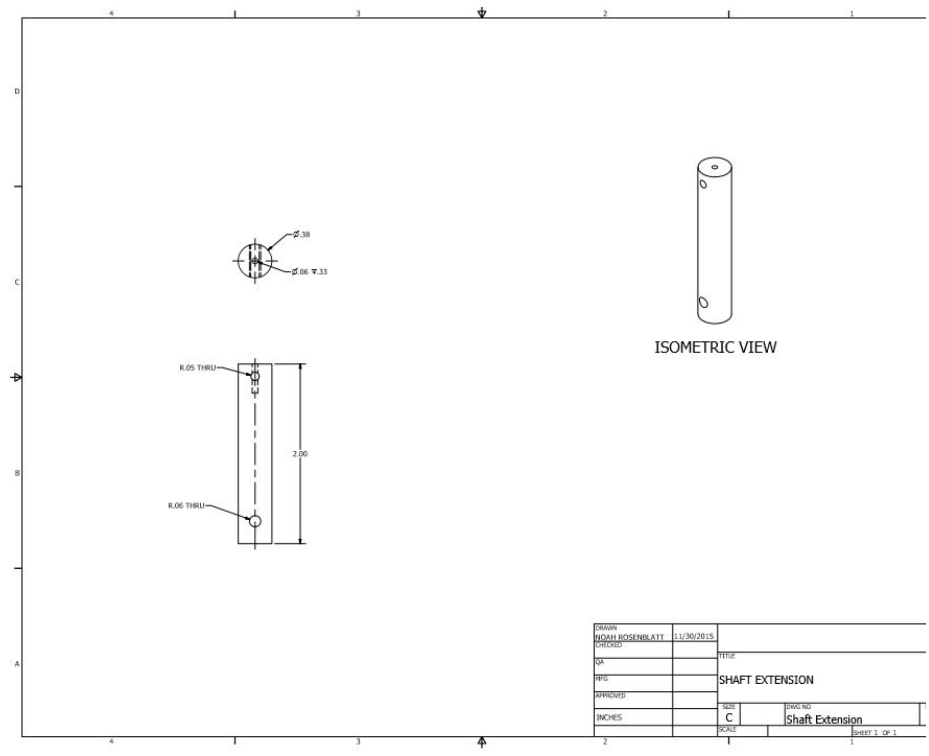

Shaft Extension.pdf

Figure 7.1.2: *Original Motor Housing Shaft Extension

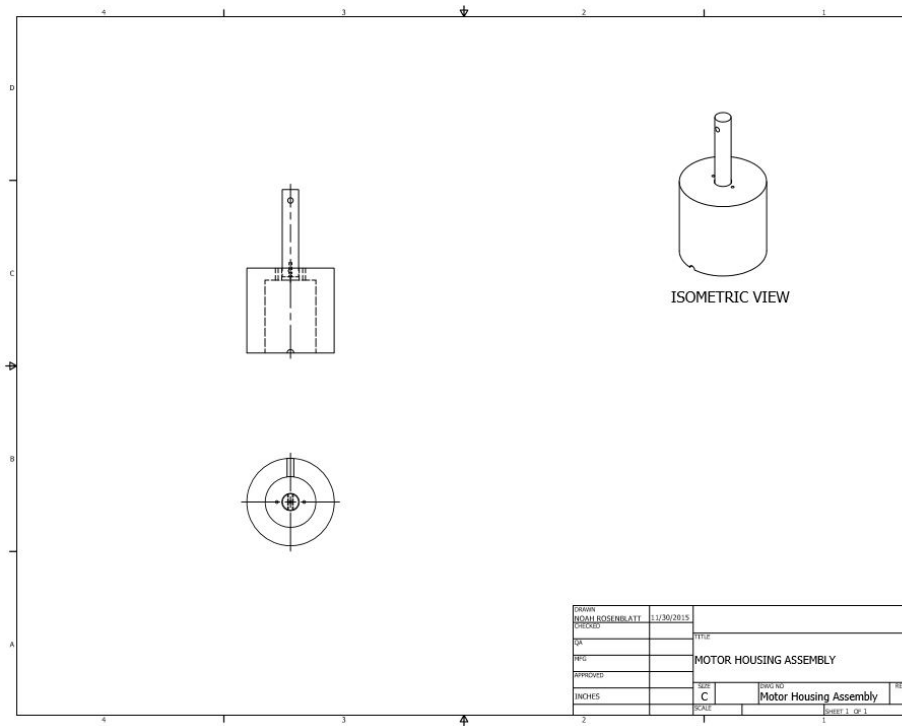

Motor Housing Assembly.pdf

Figure 7.1.3: *Original Motor Housing Assembly

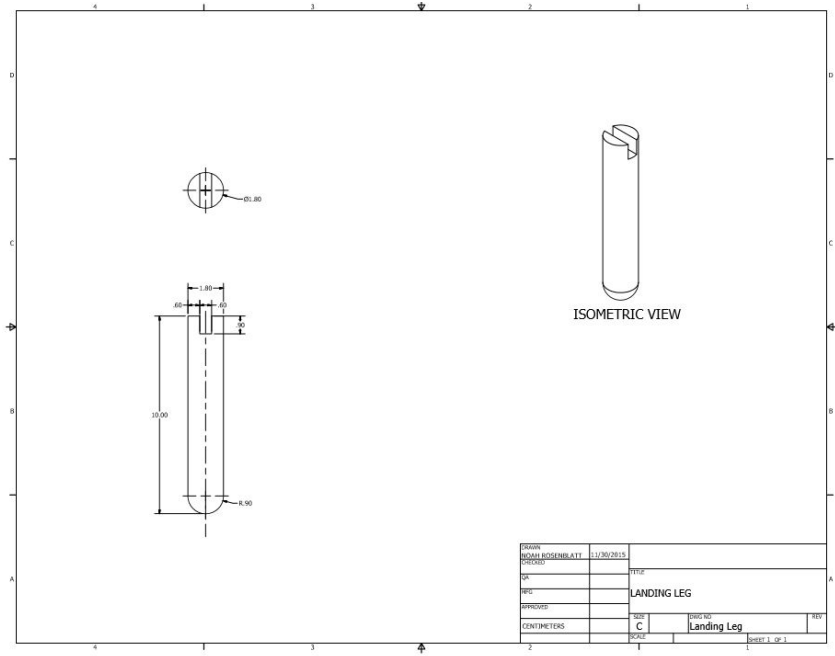

Landing Leg.pdf

Figure 7.1.4: Landing Support Legs

7.1.2 Sourcing instructions

Refer to Appendix B in the column titled "SOURCE".

7.2 Final Presentation

7.2.1 A live presentation in front of the entire class and the instructors (this section may be left blank)

7.2.2 A link to a video clip version of 1

<https://www.youtube.com/watch?v=FUVPQbR9IAQ&feature=youtu.be>

A video of a recreation of our in-class presentation.

7.3 Teardown

The working prototype for the drone was cleared of all University owned components, such as the transmitter, receiver, servos, and servo speed controller. The final prototype will be kept by the team members for further experimentation outside of the design project scope. The Machine Shop and Jolley 110 were cleaned as per the teardown instruction.

8 Discussion

8.1 Using the final prototype produced to obtain values for metrics, evaluate the quantified needs equations for the design. How well were the needs met? Discuss the result.

It should be noted that, for the final prototype, two metrics no longer applied: the weight of the center controller, given that the design no longer involves a complex mechanism, and the illuminance, given that the design no longer includes an LED. Nonetheless, the prototype scored better than three of the four concepts. To achieve a more desirable product, the next revision will be modified so that the total happiness increases.

The following table summarizes our performance results.

Metrics	Units	Best Value	Worst Value	Actual Value	Normalized Metric Happiness
Diameter of coverage	In.	30	12	18	0.33
Angle of wings from horizontal	Degrees	25	5	10	0.25
Flight time on full charge	Minutes	120	30	40	0.11
Volume of drone	In. ³	200	1000	400	0.75
Total weight	lbf	4	15	2.6	1.13
Max horizontal velocity	ft/s	22	7	15	0.53
Power generated by motors	ft-lbf/s	500	200	450	0.83
Lift coefficient	Dimensionless	0.6	0.2	0.5	0.75
Minimum age for use	Years	6	12	12	0
Illuminance	Lux	50	20	0	-0.67
Estimated cost of development	USD	0	500	383	0.23

Table 8.1.1: Scoring of Prototype By Category

	Total Happiness
Concept 1	0.644
Concept 2	0.266
Concept 3	0.398
Concept 4	0.473
Prototype	0.559

Table 8.1.2: Actual Concept Scoring

8.2 Discuss any significant parts sourcing issues? Did it make sense to scrounge parts? Did any vendor have an unreasonably long part delivery time? What would be your recommendations for future projects?

Overall, the sourcing process went very smoothly. Most of the parts we needed were easily available online or in stores like Home Depot. Our main issue was with the shipping speed of many of the hobby websites and Amazon vendors we purchased from. Generally, we tried to pick the least expensive part in order to stay under budget and leave some money for discretionary spending later in the project. But shipping costs quickly added up and we realized we needed to prioritize somehow. We decided to pay for expedited shipping on only the parts we needed to begin the drone (like the Flamewheel kit) and let the rest arrive later when we were ready to begin setting up the drone's electronics. We scrounged several parts including the parasol's servo from the mechanical engineering department, and were able to use fabric, glue and tools already owned by the team. Our primary recommendation for future teams would be to check where parts are shipping from before counting on using them: we had several situations where we found a component that seemed to be exactly what we needed but ended up being located in Europe or China.

8.3 Discuss the overall experience:

8.3.1 Was the project more or less difficult than you had expected?

The project was considerably more difficult than we had originally anticipated due to a combination of unforeseen difficulties and scheduling conflicts as the semester became busier. Ultimately though we were able to make compromises and get the work finished that needed to be done. The single most difficult part of the process was getting the controller to work with the drone motors, and troubleshooting that issue took an enormous effort and some much needed guidance from our MVP TA Ethan. A close second in difficulty was the revision process in finalizing our shading mechanism and ironing out the last few issues. We were successful in overcoming this obstacle as well and our project was overwhelmingly successful in the end.

8.3.2 Does your final project result align with the project description?

We met the major stipulation of our project which was to effectively provide shade from a drone. Secondly to that we were able to achieve some other goals as well, such as keeping the drone relatively lightweight and efficient in its use of space so that it isn't unnecessarily bulky. Additionally, we were successful in implementing a system that allows for the shading to be deployed and retracted midflight without initial setup required. The fact that we were able to meet all these design considerations is fairly significant as meeting every single major task in a project isn't always feasible, thus our accomplishment here has great merit.

8.3.3 Did your team function well as a group?

Our team functioned reasonably together. We did struggle with making big decisions in a timely fashion, and spent an undue amount of time discussing and worrying over some of the more minute details. This was more of a struggle at the beginning of the project in the initial design and planning phases, and as the project progressed we were able to improve our decision making and reach quicker resolutions. There were times when someone couldn't make a meeting or had a conflict and the rest of the group were able to accommodate schedule changes and be supportive.

8.3.4 Were your team member's skills complementary?

Since everyone in the team is a mechanical engineer there was little diversity regarding general knowledge, however, everyone has had different technical experiences which brought to the table different perspectives on how to resolve issues and design components. In this way we were able to blend our different views and experiences together in order to come up with an overarching scheme and create a unified approach that was effective in seeing the project through successfully and complementing our abilities to their fullest.

8.3.5 Did your team share the workload equally?

For the majority of the project we tried to meet together as a group as much as possible, going to great lengths to work around class and extracurricular conflicts. We were fairly successful with this throughout the semester, with a few hiccups at the end when schedules became overly complicated and difficult to coordinate. Everyone contributed a great deal of time towards the completion of the project and is proud of what we've accomplished.

8.3.6 Was any needed skill missing from the group?

Between the three of us we possessed most of the technical knowhow that was necessary to complete the project, however an area that we fell short in was in programming. We spent a great deal of time watching tutorials and YouTube video explanations in order to make up for this gap in our knowledge base, however we were also able to rely upon our extremely knowledgeable TAs for advice and assistance with troubleshooting this area.

8.3.7 Did you have to consult with your customer during the process, or did you work to the original design brief?

We consulted with our customer initially to outline our user needs and clarify any points of uncertainty. Very early in the design process it was necessary to seek a concession on the exact nature of drone and draw a distinction for the prominent idea for our drone being a parasol instead of an umbrella. After this last issue was dealt with we met with the customer as was required for prototype updates.

8.3.8 Did the design brief (as provided by the customer) seem to change during the process?

Originally when we set out on this drone project it was intended to be an umbrella drone, as was touched upon earlier. The feasibility of this endeavor was established early on during the initial concept sketch part of the project in which we decided that this was not a realistic goal to be able to achieve and went to professor Jakiela for a reprieve which we received in the form of reducing the umbrella nature of the drone to that of a parasol. This change is relatively major and minor, as it allowed us to approach the project realistically without drastically altering its fundamental nature.

8.3.9 Has the project enhanced your design skills?

This project definitely enhanced our design skills, stretching the bounds of our creativity in coming up with a suitable and realistic design. Learning how to adapt our design and come up with new ones was an important learning experience, since very rarely do things work out perfectly the first time around. We gained an appreciation for the importance of design difficulty as it relates to machining, as the best design isn't useful if it is impossible to fabricate.

8.3.10 Would you now feel more comfortable accepting a design project assignment at a job?

We absolutely would feel comfortable accepting a design project at a job, not to say that we probably wouldn't still be a little nervous and apprehensive, but confident in our ability. The most important takeaways that we feel are most applicable are teamwork skills and the importance of setting achievable goals. The teamwork is of obvious necessity as real world design projects are typically team oriented. Setting achievable goals is important as well since the absence of goals strongly affects the timeliness of project completion, while unrealistic goals can hang up the project and prevent it from moving forward.

8.3.11 Are there projects that you would attempt now that you would not attempt before?

We all feel more comfortable with the idea of applying metrics to projects in order to determine which aspects are the most important and provide guidance for what to focus on. We also feel that we would be able to confidently approach a project involving multiple instances of design and redesign work. A more complex project would most assuredly have several layers of design needed, and the potential for one area to cause a ripple effect and affect the other design processes would be present, a project that we wouldn't be so nervous to undertake anymore. Projects that utilize heavy use CAD and hands on machining would also appear to be less daunting and we would more readily accept such a project.

9 Appendix A - Parts List

Part #	Part Name	Quantity
1	Flame Wheel F450 Frame	1
2	Propellers	4
3	Motors	4
4	ESCs/Speed Controlers	4
5	3s Lipo Battery	1
6	Naza Lite	1
7	Naza Lite LED	1
8	Reciever	1
9	Female Battery Plug-in	2
10	Metal Fish Eyes	8
11	Shading Fabric	4
12	Naza Power Supply	1
13	Support Legs	4
14	Plastic Cable Ties	16
15	String	8
16	Shading Servo	1
17	BEC	1
18	Servo Speed Controler	1
19	Transmitter	1
20	Naza Lite tripple wires	8

10 Appendix B - Bill of Materials

Part	Source	Model #	Quantity	Unit Cost
Flamewheel F450 Frame Kit	30SDrones	DJI-FW450	1	\$189.00
Turnigy 11.1V Lipo 3s Battery	Amazon	T2200.3S.20	1	\$18.14
Naza Lite Flight Controller	HeliPal	DJI-NAZA-M	1	\$69.00
Turnigy E3 Compact Charger	Amazon	B00XU4ZR06	1	\$13.47
Castle BEC	St. Louis RC	CSE010-0004-00	1	\$21.21
Power Pro 50 lb Fishing Line	Walmart	196048	1	\$13.96
Bernzomatic Electrical Solder	Home Depot	327793	1	\$7.97
Bernzomatic Auto Ignite Butane Torch	Home Depot	335258	1	\$19.97
Bernzomatic Butane Gas Refill Canister	Home Depot	329853	1	\$4.97
Colored Electrical Tape 5-pack	Home Depot	GTPC-550	1	\$4.27
Husky Precision Pliers	Home Depot	48068	1	\$7.97
Gorilla Epoxy	Walmart	1202080	1	\$4.97

Spektrum DX6i Transmitter	Scavenged	DX6i	1	\$0.00
Female Battery Connectors	Amazon	B00G197NHW	1	\$5.75
Lexan Plastic Legs	Fabricated	Scavanged	4	\$0.00
Shading Fabric	Fabricated	Scavenged	4	\$0.00
Parallax Standard Servo	Supplied	Scavenged	1	\$0.00
Shading Mechanism Speed Controller	Supplied	Scavenged	1	\$0.00
Gorilla Tape	Home Depot	60035	1	\$0.00
Mini Zip Ties	Home Depot	GT-100M(40)	1	\$2.38
Spektrum AR6100e Reciever	Scavenged	AR6100e	1	\$0.00
			Total Cost	\$383.03

11 Appendix C - CAD Models



Base Plate.ipt



Top Plate.ipt



Support Rod.ipt



Design Project (3).ipj



Cylinder Container.ipt



Shaft Extension.ipt



Motor Housing Assembly.iam



Landing Leg.ipt



Shading Mechanism (2).iam

12 Annotated Bibliography

- 1.) "Add-a-Motor 31423 Remote Motorized Umbrella Controller." *Smart Home*. Smart Home, n.d. Web. 06 Dec. 2015. <<http://www.smarthome.com/add-a-motor-31423-remote-motorized-umbrella-controller.html>>.

This is the description of a remote-controlled umbrella opening mechanism much like the one we used in our final design of the parasol drone.

- 2.) "AIRWORTHINESS STANDARDS: PROPELLERS." *ECFR — Code of Federal Regulations*. U.S. Government Publishing Office, n.d. Web. 06 Dec. 2015. <<http://www.ecfr.gov/cgi-bin/text-idx?SID=46dfd761a800393ab9be1689090dec5a&node=pt14.1.35&rgn=div5>>.

These standards discuss proper installation, maintenance, testing and operation of propellers.

- 3.) "ASTM D6603-12: Standard Specification for Labeling of UV-Protective Textiles." *American National Standards Institute*. ANSI, n.d. Web. 6 Dec. 2015. <<http://webstore.ansi.org/RecordDetail.aspx?sku=ASTM+D6603-12>>.

These UV protection standards helped us understand how to label our prototype and what standards it would need to meet to be marketed as a UV protective item.

- 4.) "ASTM D6544-12: Standard Practice for Preparation of Textiles Prior to Ultraviolet (UV) Transmission Testing." *American National Standards Institute*. ANSI, n.d. Web. 6 Dec. 2015. <<http://webstore.ansi.org/RecordDetail.aspx?sku=ASTM+D6544-12>>.

These UV protection standards showed what types of fabrics can be considered UV-protective and discussed the conditions they should be exposed to to test their effectiveness. This is important for us because our drone will be used outdoors in many temperatures, humidities and weather conditions.

- 5.) "Camera Positioning Kit (500mm)." *Helipal.com*. HeliPal, n.d. Web. 06 Dec. 2015. <http://www.helipal.com/camera-positioning-kit-500mm.html?gclid=CjwKEAiA1ozBRDomsWasvKh4S8SjADSIZkqOvRzCqKERXhIXqEGfQp7DsZP0v5xbRX_0j_sIDBNvBoCVUfw_wcB>.

This website shows the listing for a camera mounting kit much like the one we planned to create for our initial design prompt (camera drone).

- 6.) Caubel, Christine. ROTARY-WING DRONE WITH GEARLESS-DRIVE AND FAST-MOUNTING PROPELLERS. Patent US 20150129711. 14 May 2015. Print.

We investigated this patent for a drone to see how some of our bulkier concepts might be more easily disassembled and stored.

7.) "Energy Management Guide for Selection and Use of Single-Phase Motors." *National Electrical Equipment Manufacturers*. NEMA, n.d. Web. 06 Dec. 2015. <<https://www.nema.org/Standards/Pages/Energy-Management-Guide-for-Selection-and-Use-of-Single-Phase-Motors.aspx>>.

This guide discusses the selection of the proper single-phase motors for different applications and operating conditions. It also talks about how to decrease the risk of failure when installing and operating the motors, which was really important for our drone- if one of the motors was not running right, the prototype could crash during testing.

8.) "Federal Aviation Administration." *Unmanned Aircraft Systems*. US Department of Transportation, n.d. Web. 06 Dec. 2015. <<https://www.faa.gov/uas/>>.

This website informs consumers about regulations and codes regarding the purchase and safe operation of unmanned aircraft systems (drones). This information is incredibly important for our project because if we were marketing our drone to the public, we would be required to include information on these and other laws and guidelines.

9.) Flexible Protective Cover. Wolfgang Stark, assignee. Patent US20090008048 A1. 8 Jan. 2009. Print.

This patent for a flexible automobile sunroof cover gave us some good ideas for the Window Shade Drone concept, but we did not ultimately choose this design.

10.) Savoy, Guillaume, Yoni Benatar, and Francois Callou. Support Block for a Motor of a Rotary Wing Drone. Patent US 20150129711. 27 Sept. 2012. Print.

This patent provided insight into alternative designs for the drone's motor support blocks. However, since we ended up using a kit to build our quadcopter, this information was not relevant to our final design.

11.) Ultra Violet Protective Panel. Mary Austin, assignee. Patent US 2010022149 A1. 28 Jan. 2010. Print.

This patent was reviewed for a two-layered fabric that protects the wearer or user from 99% of UVA and UVB radiation. We used a very similar material for the parasol portion of our final design.