

Washington University in St. Louis

Washington University Open Scholarship

Mechanical Engineering Design Project Class

Mechanical Engineering & Materials Science

Fall 12-7-2017

Macroscopic Model of a Cilium Appendage

Laura Barber

Washington University in St. Louis

Rachel Mickelson

Washington University in St. Louis

Wilson Roen

Washington University in St. Louis

Isabella Merz

Washington University in St. Louis

Follow this and additional works at: <https://openscholarship.wustl.edu/mems411>



Part of the [Mechanical Engineering Commons](#)

Recommended Citation

Barber, Laura; Mickelson, Rachel; Roen, Wilson; and Merz, Isabella, "Macroscopic Model of a Cilium Appendage" (2017). *Mechanical Engineering Design Project Class*. 87.

<https://openscholarship.wustl.edu/mems411/87>

This Final Report is brought to you for free and open access by the Mechanical Engineering & Materials Science at Washington University Open Scholarship. It has been accepted for inclusion in Mechanical Engineering Design Project Class by an authorized administrator of Washington University Open Scholarship. For more information, please contact digital@wumail.wustl.edu.



Washington University in St. Louis

SCHOOL OF ENGINEERING & APPLIED SCIENCE

Executive Summary

The goal of this project is to develop a macroscopic model of the cilia appendage and a realistic testing environment for the model. The model should be created with materials that effectively replicate the material and mechanical properties of the appendage in the human body. Additionally, the testing environment should mimic the viscous fluid that surrounds cilia in the human body to allow for more accurate testing. The fluid's flow should be parallel to the model and induce instability in the system. This instability should force the cilia model to oscillate like a flag in the wind. Upon completion of this project, our model should allow testers to gain a deeper understanding of cilia's motion by observing and measuring these oscillations. Ideally, our model and testing environment will be transportable and easy to set up. This project is important because cilia malfunction can lead to many different diseases in the human body.

MEMS 411: Senior Design Project

Macroscopic Cilium Appendage Model

Laura Barber

Isabella Merz

Rachel Mickelson

Wilson Roen

TABLE OF CONTENTS

List of Figures	5
List of Tables	6
1 Introduction and Background Information	7
1.1 Initial Project Description	7
1.2 Existing Products	7
1.3 Relevant Patents	8
1.4 Codes & Standards	11
1.5 Project Scope	11
1.6 Project Planning	12
1.7 Realistic Constraints	12
1.7.1 Functional	12
1.7.2 Safety	13
1.7.3 Quality	13
1.7.4 Manufacturing	13
1.7.5 Timing	13
1.7.6 Economic	13
1.7.7 Ergonomic	13
1.7.8 Ecological	14
1.7.9 Aesthetic	14
1.7.10 Life Cycle	14
1.7.11 Legal	14
1.8 Revised Project Description	14
2 Customer Needs & Product Specifications	15
2.1 Customer Interviews	15
2.2 Interpreted Customer Needs	16
2.3 Target Specifications	16
3 Concept Generation	18
3.1 Functional Decomposition	18
3.2 Morphological Chart	18
3.3 Concept #1 – “Spaghetti model”	20
3.4 Concept #2 – “Membrane model”	21
3.5 Concept #3 – “wheel model”	22

3.6	Concept #4 – “pump model”	23
3.7	Concept #5 – “pool float model”	24
3.8	Concept #6 – “vertical tank”	25
4	Concept Selection	26
4.1	Concept Scoring Matrix.....	26
4.2	Explanation of Winning Concept Scores.....	27
4.3	Explanation of Second-Place Concept Scores for Environment	28
4.4	Explanation of second-Place Concept Scores for Model.....	28
4.5	Summary of Evaluation Results	28
5	Embodiment & Fabrication plan	29
5.1	Isometric Drawing with Bill of Materials.....	29
5.2	Exploded View	32
5.3	Additional Views	33
6	Engineering Analysis.....	34
6.1	Engineering Analysis Results	34
6.1.1	Motivation.....	34
6.1.2	Summary Statement of the Analysis.....	34
6.1.3	Methodology.....	38
6.1.4	Results.....	39
6.1.5	Significance	39
6.2	Product Risk Assessment.....	42
6.2.1	Risk Identification	42
6.2.2	Risk Heat Map	44
6.2.3	Risk Prioritization.....	44
7	Design Documentation	45
7.1	Performance Goals.....	45
1)	The viscoelastic constant of the model will be within +/- 10% of the theoretical viscoelastic constant of cilia.....	45
2)	The model and testing environment will be watertight.	45
3)	The model will exhibit proper bending stiffness within +/- 10% of the theoretical bending stiffness of cilia.	45
4)	The model will sustain oscillation in response to fluid flow for at least 5 seconds.	45
5)	After using the testing environment, any spillage will be able to be cleaned up by 1 standard paper towel.	45

7.2	Working Prototype Demonstration.....	45
7.2.1	Performance Evaluation.....	45
7.2.2	Working Prototype – Video Link	45
7.2.3	Working Prototype – Additional Photos.....	46
8	Discussion.....	51
8.1	Design for Manufacturing – Part Redesign for Injection Molding.....	51
8.1.1	Draft Analysis Results	51
8.1.2	Explanation of Design Changes.....	51
8.2	Design for Usability – Effect of Impairments on Usability.....	51
8.2.1	Vision.....	51
8.2.2	Hearing	52
8.2.3	Physical.....	52
8.2.4	Language.....	52
8.2	Overall Experience	52
8.2.1	Does your final project result align with the initial project description?.....	52
8.2.2	Was the project more or less difficult than you had expected?	52
8.2.3	In what ways do you wish your final prototype would have performed better?	52
8.2.4	Was your group missing any critical information when you evaluated concepts?.....	53
8.2.5	Were there additional engineering analyses that could have helped guide your design?....	53
8.2.6	How did you identify your most relevant codes and standards and how they influence revision of the design?	53
8.2.7	What ethical considerations (from the Engineering Ethics and Design for Environment seminar) are relevant to your device? How could these considerations be addressed?	53
8.2.8	On which part(s) of the design process should your group have spent more time? Which parts required less time?	53
8.2.9	Was there a task on your Gantt chart that was much harder than expected? Were there any that were much easier?.....	54
8.2.10	Was there a component of your prototype that was significantly easier or harder to make/assemble than you expected?	54
8.2.11	If your budget were increased to 10x its original amount, would your approach have changed? If so, in what specific ways?.....	54
8.2.12	If you were able to take the course again with the same project and group, what would you have done differently the second time around?	54
8.2.13	Were your team member’s skills complementary?.....	54
8.2.14	Was any needed skill missing from the group?	54

8.2.15 Has the project enhanced your design skills?55

8.2.16 Would you now feel more comfortable accepting a design project assignment at a job? ...55

8.2.17 Are there projects you would attempt now that you would not have attempted before?55

9 Appendix A – Parts List56

10 Appendix B - CAD Models57

11 Annotated Bibliography.....65

LIST OF FIGURES

Figure 1: Screenshot taken from the linked video of the first macroscopic cilia design.	7
Figure 2: Screenshot taken from the linked video of a second macroscopic cilia design.	8
Figure 3: 3D View of the Robot Arm.....	9
Figure 4: Cross Sectional View of the Robotic Arm.....	9
Figure 5: 3D View of the Snake	10
Figure 6: Cross-Sectional View of the Snake.....	10
Figure 7: Gant Chart	12
Figure 8: Function Tree of the Cilia Model.....	18
Figure 9: Spaghetti Model	20
Figure 10: Membrane Model.....	21
Figure 11: Wheel Model.....	22
Figure 12: Pump Model.....	23
Figure 13: Pool Float Model.....	24
Figure 14: Vertical Tank.....	25
Figure 15: Model Weighted Scoring Matrix	26
Figure 16: Model Analytic Hierarchy Process	26
Figure 17: Environment Weighted Scoring Matrix	27
Figure 18: Environment Analytic Hierarchy Process	27
Figure 19: Isometric Drawing of Cilium Model with Bill of Materials	30
Figure 20: Isometric Drawing of Environment with Bill of Materials	31
Figure 21: Exploded View of Cilium Assembly	32
Figure 22: Cilium Assembly CAD Model.....	33
Figure 23: Schematic of tubes with dimensions	38
Figure 24: Original CAD drawing of the macroscopic cilium appendage model	40
Figure 25: Current CAD drawing of the macroscopic cilium appendage model	41
Figure 26: Heat map for various risks	44
Figure 27: Close up view of cilium model	46
Figure 28: Close up view of 3D printed spacer	46
Figure 29: Top down view of prototype setup.....	47
Figure 30: Prototype setup.....	48
Figure 31: Close up view of acrylic tube attachment to base.....	49
Figure 32: Close up view of working prototype with water running through tubes.....	50
Figure 33: Spacer from above and below before draft was added. Key included for reference.....	51
Figure 34: Spacer from above and below after draft was added	51
Figure 35: Spacer CAD	57
Figure 36: Rod CAD.....	58
Figure 37: Top Plate CAD	59
Figure 38: Rod Connections CAD.....	60
Figure 39: Environment CAD	61
Figure 40: Pump CAD Model.....	62
Figure 41: Cilium Model CAD.....	63
Figure 42: Cilium Assembly CAD Model.....	64

LIST OF TABLES

Table 1: Customer Interviews 16
Table 2: Customer Needs 16
Table 3: Target Specifications* 17
Table 4: Morphological Chart for the Cilia Model 20
Table 5: Micro and Macro Scale Mechanical Properties of Cilia 34
Table 6: Properties of Cilia and Model Used to Calculate Force 35
Table 7: Parts List 56

1 INTRODUCTION AND BACKGROUND INFORMATION

1.1 INITIAL PROJECT DESCRIPTION

The goal of this project is to develop a macroscopic model of the cilia appendage and a realistic testing environment for the model. The model should be created with materials that effectively replicate the material and mechanical properties of the appendage in the human body. Additionally, the testing environment should mimic the viscous fluid that surround cilia in the human body to allow for more accurate testing. Upon completion of this project, our model should allow testers to gain a deeper understanding of cilia's motion. This is relevant because cilia malfunction can lead to many different diseases in the human body.

1.2 EXISTING PRODUCTS

Independent Study Project in Dr. Bayly's Lab – Initial Design

https://www.youtube.com/watch?v=4KXzN3t_U10

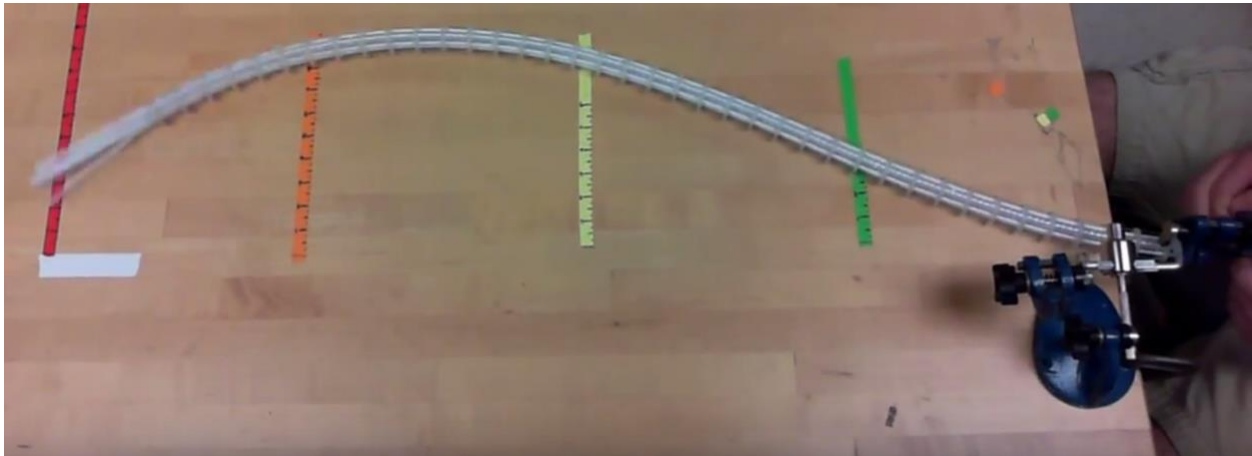

Figure 1: Screenshot taken from the linked video of the first macroscopic cilia design.

As shown above, the first design of a macroscopic cilia designed in Dr. Bayly's lab was created using plastic tubing held in place by running the tubes through smaller plastic disks. It was operated manually as seen in the right of the figure. In order to measure the motion of the model, colored rulers were placed on the table. This initial design successfully mimicked the shape of the cilia and also created a wave-like motion. However, this wave-like motion is not random like that of a cilia. This model is also placed on top of a table, which creates friction and therefore prevents it from effectively representing the environment cilia experience in viscous bodily fluids.

Independent Study Project in Dr. Bayly's Lab – Second Design

<https://www.youtube.com/watch?v=Rsr93B8GXjk>



Figure 2: Screenshot taken from the linked video of a second macroscopic cilia design.

The second design for the macroscopic cilia was made using flexible plastic tubing as well as rubber bands, and circular plastic disks to hold the tubes together as shown in the figure above. The product was connected to a gearbox in order to induce motion, seen in the bottom of the image. Though this design was able to successfully mimic the shape of the cilia, from the video, it appears that it is not able to achieve the speed and random nature of the cilia's motion. Additionally, similar to the initial model, it operates on a table top which induces a large amount of friction as the object moves and restraining the model from mimicking the viscosity of the environment that cilia experience inside of the human body.

1.3 RELEVANT PATENTS

EP1395398B1 - Link assembly for a snake like robot arm

<https://patents.google.com/patent/EP1395398B1/en?q=robotic+snake>

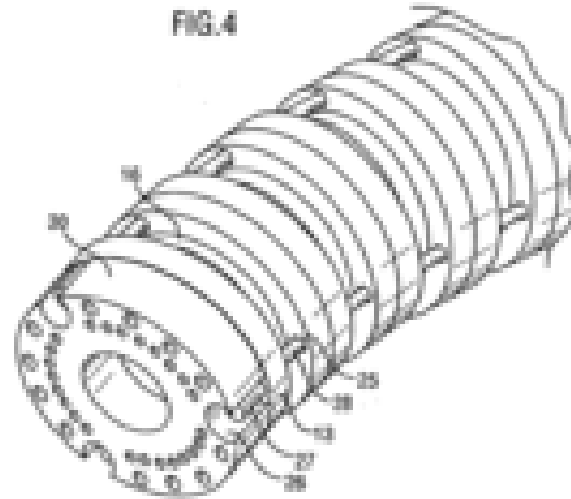

Figure 3: 3D View of the Robot Arm

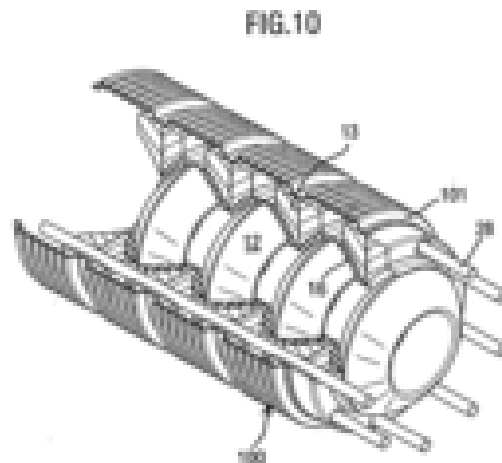

Figure 4: Cross Sectional View of the Robotic Arm

Robert Buckingham and Andrew Crispin's patent describes a robotic arm that has the ability to move in a snake like manner, similar to how the cilia my team and I are developing will need to move. The arm is made out of spaced out rings, joined by hip joints, that have an elastic layer in order to reduce friction between the sections that have limited ranges of motion relative to each other. As a result, the patented arm as a whole is able to extend along its axis and move in a snake like manner.

US5386741A – Robotic Snake

<https://patents.google.com/patent/US5386741A/en?q=snake>

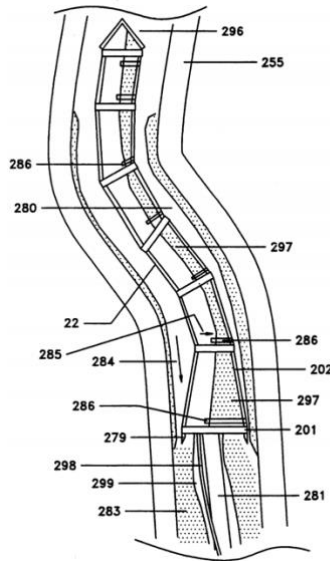

Figure 5: 3D View of the Snake

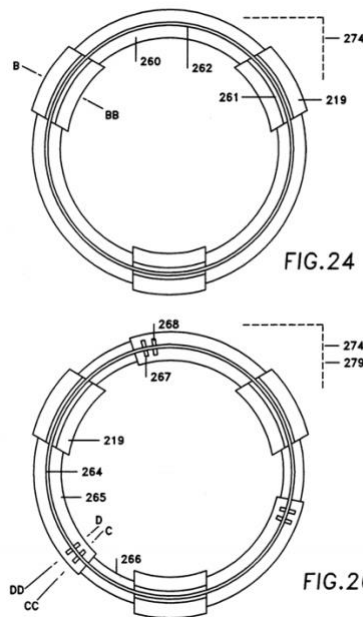

Figure 6: Cross-Sectional View of the Snake

Brian Rennex’s robotic snake is a technology used in many medical applications such as catheters. It will be useful to my team and I while we are creating our project as it is a rigid, yet flexible, structure comprised of interconnected arms. Each of these arms can be actuated individually, allowing the object to take very versatile shapes very accurately even when it is traveling through viscous fluids such as blood. Similar to this snake, cilia take on very versatile shapes in a variation of different vicious bodily fluids.

1.4 CODES & STANDARDS

29 CFR 1910 (Standard for Safety) - “Such surfaces or areas include, but are not limited to, ground levels, floors, roofs, ramps, runways, excavations, pits, tanks, materials, water, equipment, and similar surfaces and structures, or portions thereof.”

ASTM E715 - 80 (Standard for Safety) - “The temperature within the bath chamber shall be controllable by an automatic device and shall be uniform within the tolerances given in Table 1 for the particular type of bath when tested in accordance with 4.1.”

1.5 PROJECT SCOPE

1. Write an overview of the purpose of the project
The purpose of the project is to create a macroscopic model of cilia/flagella that can be used to understand and demonstrate the oscillatory motion of the organelles.
2. Identify the customer for your eventual product
Dr. Bayly, people at the medical school, students at a science museum
3. Specify the value or benefits to the customer
It will serve as a proof of concept and demonstration of how cilia/flagella work in order for physicians to understand the movement better. This better understanding will allow for new treatments of diseases involving cilia, like primary ciliary dyskinesia.
4. Define the project goals
We will develop a macroscopic model of the cilia organelle appropriately scaled to match observed material and mechanical properties of cilia and the environment they interact with. We will measure these goals by assessing what the appropriate viscosity of a testing fluid should be as well as the known mechanical properties of cilia. We will create an initial prototype that is able to exhibit oscillatory behavior in the proper testing environment so that further testing can be performed to gain a deeper understanding of the movement and mechanics of cilia.
5. Identify what is in scope
Mechanical and material properties of cilia successfully modeled. Testing environment accurately mimicked
6. Identify what is out of scope
Attaching cilia to moving object. Having a micro-controller
7. Identify a few critical success factors for your project
Must be able to operate in the viscous testing environment and must exhibit successful oscillations.
8. Identify project assumptions
We are assuming that cilia move based on the dynamic instability theory – that the interaction with the fluid causes the cilia to self-excite and move with an oscillatory motion.
9. Identify project constraints

Budget, time – might be difficult to create both the environment and model in time, need to first meet mechanical and material properties before dealing with the oscillatory motion, bending stiffness – might be hard to scale up material properties

10. Identify key project deliverables

A model that in order of importance first replicates mechanical properties, then the correct testing environment, then the oscillatory motion

1.6 PROJECT PLANNING

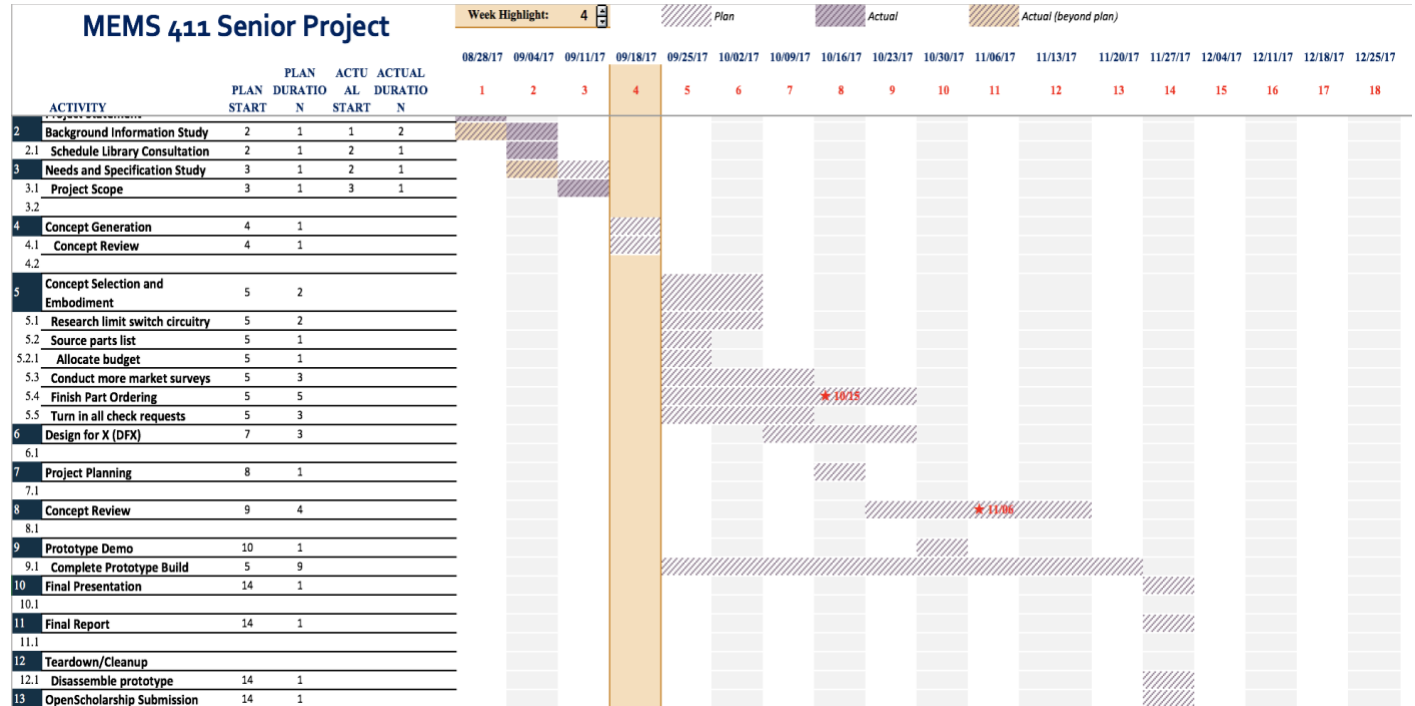

Figure 7: Gant Chart

1.7 REALISTIC CONSTRAINTS

In an ideal world, we would create a system that would perfectly match our customer needs, be a perfect model of the cilium, and also create completely accurate motion. However, our prototype has a significant number of constraints, documented below, that restrict us from doing so.

1.7.1 Functional

Our design has a multitude of functional constraints. First, our system must be portable to allow Dr. Bayly to travel with the model. This forces us to create a small enough system to pack and ship or bring on an airplane. Additionally, our system has motion of parts constraints. The model must be allowed to oscillate and move freely within the environment. Ideally, it would be great to create a model with large oscillations to increase testing accuracy. However, the importance of portability restricts us from doing so. Lastly, our system has significant material restrictions. We would love to create a smaller than 2 ft long model. However, due to availability of materials it is not possible to do so without compromising the accuracy of the bending stiffness of the model.

1.7.2 Safety

The safety constraints for our design have to do with the water in our tank and possible spillage, as well as safety with the pump. The biggest safety concern is that our tank would have some sort of leakage, and the spilled water could be a slip hazard. In order to combat this, we are using a design that will have a watertight tank, and will be a closed system so that no water will leave the tank while it is pumped through the model. Ideally, we would have warnings for possible spillage, but due to time constraints we may not be able to add these. To make this closed system, we will use a pump which will require us to consider basic pump safety as well. This could include making sure that the pump has shields and safety guards, keeping the pump from overheating, and placing the pump in a way that will keep it safe from children. In an ideal system, we would place the pump on top of the tank to streamline the design; however, this has the potential of unbalancing the tank and might not allow the pump to ventilate as well as possible. Therefore, we will place the pump on the base plate and use tubes to connect the pump to our model.

1.7.3 Quality

Because our design has not been patented, there are not any constraints that are specific to the design itself, such as regulations and standards. The relevant codes pertained to safety. However, there are some constraints in the areas of quality control and reliability. Ideally, our model would fit into a very small tank to allow for maximum portability, but in order to test it properly, the tank must be fairly wide to allow for the oscillations to occur. In the realm of reliability, ideally, our system would last for an infinite number of tests. In actuality, the pump, tubing, and epoxy may all wear out after a certain number of tests and the system may fail or leak. In this case, we would need to purchase more materials in order to keep the system working properly.

1.7.4 Manufacturing

Ideally, we would create a system with larger than 3mm tubes to allow for more fluid flow. However, manufacturing constraints keep us from producing or purchasing components that would allow us to do so while maintaining the proper bending stiffness. Additionally, we would like to purchase a large cylinder sealed at one end, almost like a graduated cylinder, but there are no existing products on the market. As a result, we will need to purchase a tube and use epoxy to seal one end of it to a sheet of acrylic.

1.7.5 Timing

In an ideal world, we would be able to spend this first semester running engineering calculations and finding the best possible materials, since our model is very math heavy and we want an accurate representation of the cilium. However, this class is only a semester long and thus we must make do with finding materials that will be fairly accurate, but may not be the best possible material. We would also like to be able to test the dynamic instability of our design multiple times, but due to the lack of time left in the semester and how long our original calculations took, we may only be able to run one or two tests. Ideally, we would be able to mold our own plastic tank, as this would allow us to make it fully watertight and the correct size. However, we might not have enough time (or funds) to make that feasible, and thus we might have to order a tube that is close enough to the correct size, and attach a bottom that will make it watertight. Actually putting together the design should not take long.

1.7.6 Economic

Ideally, we would purchase a larger acrylic tube in order to completely eliminate the risk of turbulent flow along the sides of it. While we are confident that this will not be a significant issue after conversations with Dr. Bayly our budget does not allow us to purchase a wide enough acrylic tube.

1.7.7 Ergonomic

Ideally, Dr. Bayly would like this system to be completely portable in a briefcase. However, the size of the cilium determines the size of the tank, which is rigid. This means that the system will not be able to

satisfy this constraint. Additionally, we were considering attaching the pump to the top of the system, but this will likely pose a problem with making the system too top-heavy, so the pump will need to be attached at the bottom to ensure that the system is stable. Also, ideally, the base of the cylinder that we are going to attach would be no larger than the outer diameter of the pipe, but this will also make the system likely to tip over, so a larger base will be necessary.

1.7.8 Ecological

In order to create a model of the cilium with the same physical and mechanical properties scaled up, the material we need to use for the tubing is silicone rubber. This is not the most sustainable resource choice, but for accurate properties it is necessary. We are also 3D printing the spacers for our cilia model. In an ideal world, we could find a more sustainable material to create the spacers out of, but due to time constraints we will do the 3D printing for ease of construction. Ideally, our tank would not use a lot of water. By creating a closed system, this should be mostly true, but every time that the model is moved, the tank will need to be emptied and refilled. By making our design portable, we must sacrifice some ecological benefit. However, the closed system will reduce much of our possible water use.

1.7.9 Aesthetic

Aesthetically, the tank needs to be clear so that the oscillations of the cilia can be observed easily. It is difficult to find a tank that is large enough and also clear, so we might have to compromise by getting a slightly smaller tank than originally planned. The cilium itself needs to be long and thin for an accurate representation of the appendage. However, due to size constraints of the tank and the diameter of tubes available for the model, the cilium can only be around two feet in length with tubes of 3 mm outer diameters. The aspect ratio of cilia can vary greatly, so this will still be an accurate representation but it may not be the best aspect ratio possible.

1.7.10 Life Cycle

In an ideal situation, the system would be easy to transport, would be able to operate in any environment, and would not require any outside maintenance. However, our system will likely be somewhat difficult to transport because the tank and the pump may be large and somewhat heavy. This could cause some wear and tear on the system, giving it a shorter life span. This system should also work fairly well in any environment, but if there is a leak in the system or it tips over while the pump is running, this could cause the pump to malfunction. Additionally, the pump will require maintenance and the tubes may need to be tested occasionally to ensure that water still flows freely through them.

1.7.11 Legal

Our prototype does not have any existing legal or ethical constraints. There are no existing patents, trademarks, or copyrights that we are infringing upon and our prototype is intended to cure cilia related ailments which is ethically good. We are also not performing any animal testing, spending significant funds, or using any harsh chemicals that often lead to other ethical concerns in research.

1.8 REVISED PROJECT DESCRIPTION

For our Senior Design Project we will be creating a macroscopic model of the cilium appendage. This model will need to be anatomically correct and effectively model the mechanical properties of the appendage. In addition to the model, we will be constructing an environment to test it in. Dr. Bayly believes that the motion of the cilium is caused by dynamic instability. In our testing, we will attempt to induce this dynamic instability in order to prove or disprove his theory.

2 CUSTOMER NEEDS & PRODUCT SPECIFICATIONS

2.1 CUSTOMER INTERVIEWS

Customer Data: Customer: Dr. Bayly Address: Washington University in St. Louis Date: September 13, 2017			
Question	Customer Statement	Interpreted Need	Importance
What is the objective of the project?	The objective is to show proof of concept for the dynamic instability theory and to demonstrate how cilia work in order to better understand the mechanisms behind their motion.	Macroscopic cilium appendage model produces successful oscillations and is properly scaled.	2
How will the project differ from previous models?	The model will have more quantitative analysis and more realistic testing environment.	We will need to perform more thorough analysis around bending stiffness and testing environment.	5
What should the scale of our model be?	The model should be scaled from the micron level to tabletop size.	Macroscopic cilium appendage model fits on a tabletop.	5
In what environment should the model operate?	The viscosity of the fluid should match the viscosity of the fluid in the respiratory tract and it should simulate the current that a cilium would encounter.	The cilium environment viscosity and behavior of the fluid should match the properties of the fluid in the respiratory tract relative to the cilia.	4
What parts of the cilia's structure are most important to replicate?	The cilia is made up of 9 microtubule doublets, mimicking the bending and shear stiffness is important so that the movement models that of a cilia.	Macroscopic cilium appendage model has 9 microtubule doublets. Macroscopic cilium appendage model imitates cilia properties.	5
Who is the model for?	The model is for professors, physicians, students or even kids at a science museum	Macroscopic cilium appendage model and the cilium environment is safe to use and safe for children to be around.	1

How should we induce movement for the cilia?	Currently the system is a “smart system” I would like it to be a “dumb system”.	Macroscopic cilium appendage model is a reactive system and is driven by its environmental conditions.	3
--	---	--	---

Table 1: Customer Interviews

2.2 INTERPRETED CUSTOMER NEEDS

Need Number	Need	Importance
1	Macroscopic cilium appendage model produces successful oscillations and is properly scaled.	2
2	We will need to perform more thorough analysis around bending stiffness and testing environment.	5
3	Macroscopic cilium appendage model fits on a tabletop.	5
4	The cilium environment viscosity and behavior of the fluid should match the properties of the fluid in the respiratory tract relative to the cilia.	4
5	Macroscopic cilium appendage model has 9 microtubule doublets. Macroscopic cilium appendage model imitates cilia properties.	5
6	Macroscopic cilium appendage model and the cilium environment is safe to use and safe for children to be around.	1
7	Macroscopic cilium appendage model is a reactive system and is driven by its environmental conditions.	3

Table 2: Customer Needs

2.3 TARGET SPECIFICATIONS

Metric Number	Associated Needs	Metric	Units	Acceptable	Ideal
1	1	Young’s Modulus	Pa	10^{-12} - 10^{-10}	10^{-11}
2	1	Bending Stiffness (EI)	Pa	10^{-24} - 10^{-22}	10^{-23}
3	1	Shear Stiffness	Pa	10^{-11} - 10^{-9}	10^{-10}

4	3	Density of fluid	g/L	.5-1.7	1.3
5	1 & 5	Length/Diameter	microns/nm	5-50/150-250	5-50/200
6	2	Number of consecutive oscillations	Integer	>5	>10
7	4	29 CFR 1910 (Standard for Safety) “Such surfaces or areas include, but are not limited to, ground levels, floors, roofs, ramps, runways, excavations, pits, tanks, materials, water, equipment, and similar surfaces and structures, or portions thereof.”	mL	100 mL	0 mL
8	4	ASTM E715 - 80 (Standard for Safety) “The temperature within the bath chamber shall be controllable by an automatic device and shall be uniform within the tolerances given in Table 1 for the particular type of bath when tested in accordance with 4.1.”	C	Uniform. + or - 5C	Uniform. + or - 1C

Table 3: Target Specifications*

*These specifications are based on actual cilia and will need to be appropriately scaled for a table top model.

3 CONCEPT GENERATION

3.1 FUNCTIONAL DECOMPOSITION

Function Tree for Cilia Model

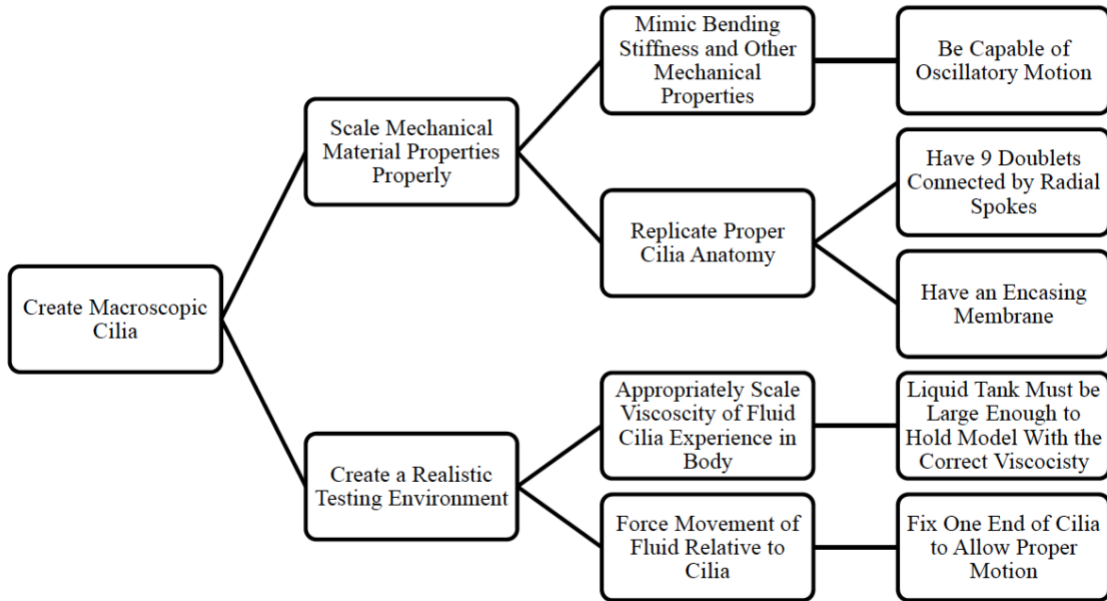
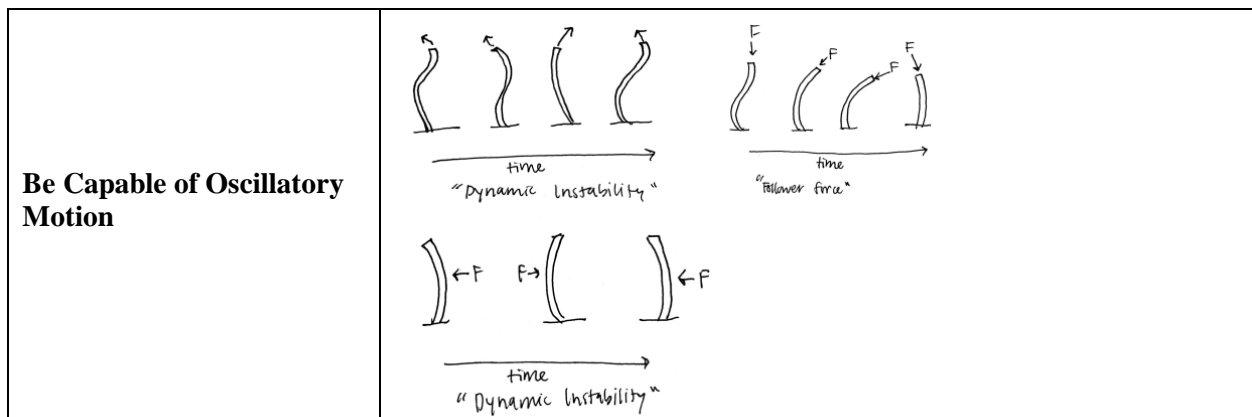
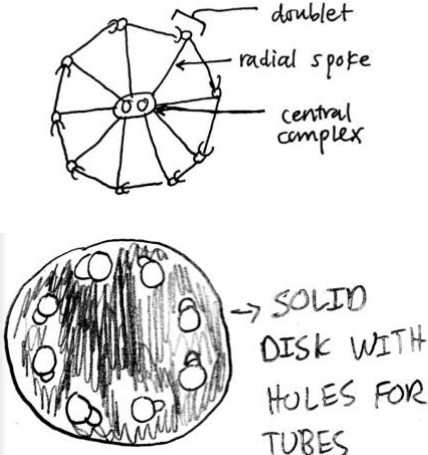
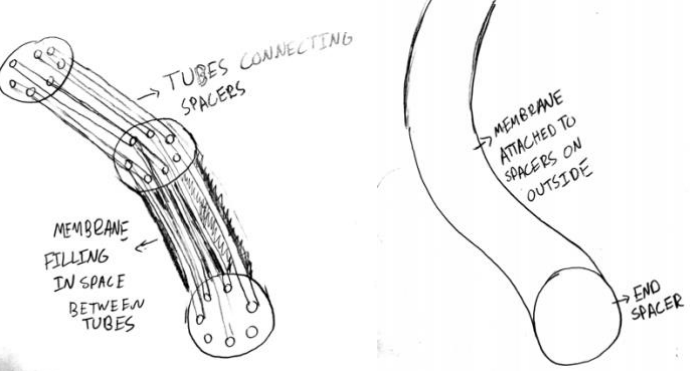



Figure 8: Function Tree of the Cilia Model

3.2 MORPHOLOGICAL CHART

Morphological Chart for Cilia Model



<p>Have 9 Doublets Connected by Radial Spokes</p>	 <p>doublet radial spoke central complex</p> <p>SOLID DISK WITH HOLES FOR TUBES</p>
<p>Have an Encasing Membrane</p>	 <p>TUBES CONNECTING SPACERS</p> <p>MEMBRANE FILLING IN SPACE BETWEEN TUBES</p> <p>MEMBRANE ATTACHED TO SPACERS ON OUTSIDE</p> <p>END SPACER</p>
<p>Liquid Tank Must be Large Enough to Hold Model with the Correct Viscosity</p>	 <p>TROUGH/POOL</p> <p>ENCLOSED TANK</p>

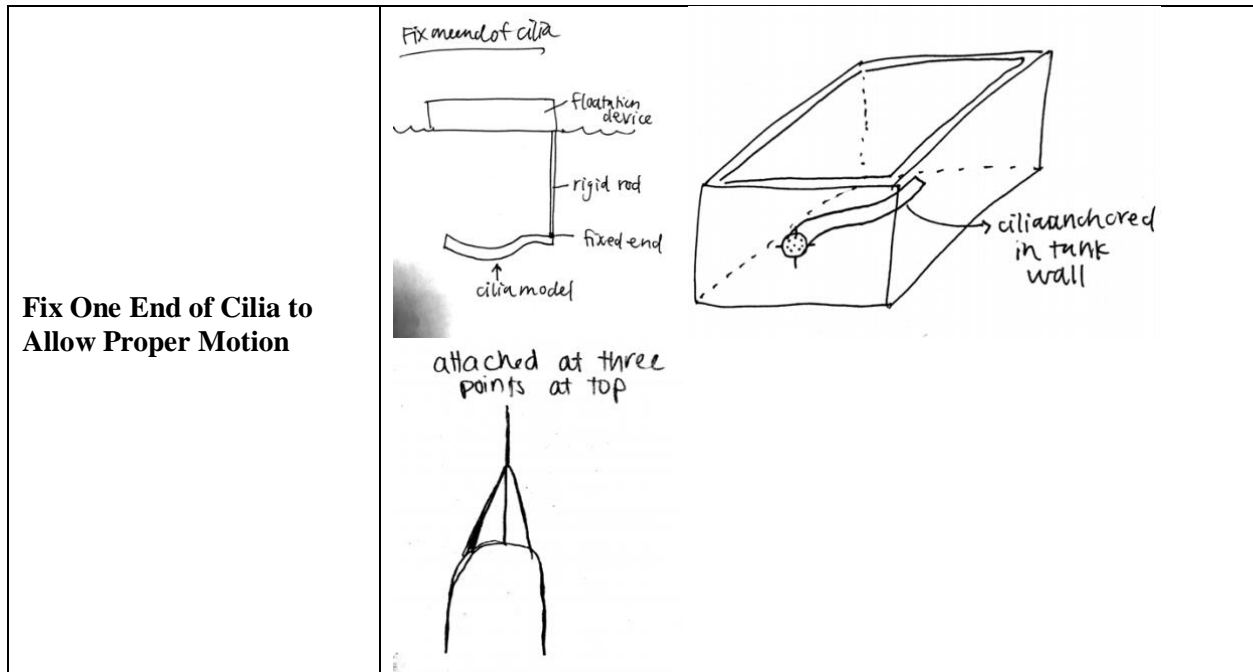

Table 4: Morphological Chart for the Cilia Model

3.3 CONCEPT #1 – “SPAGHETTI MODEL”

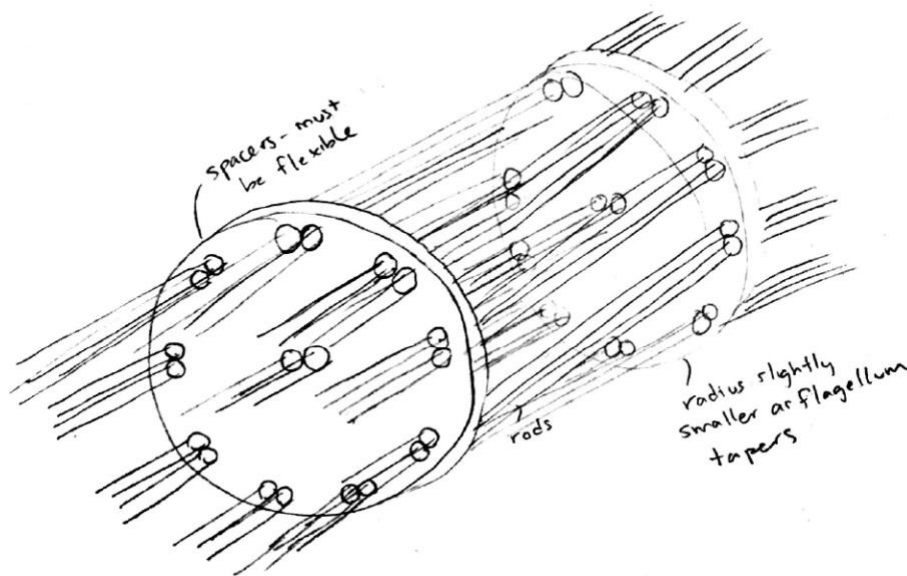
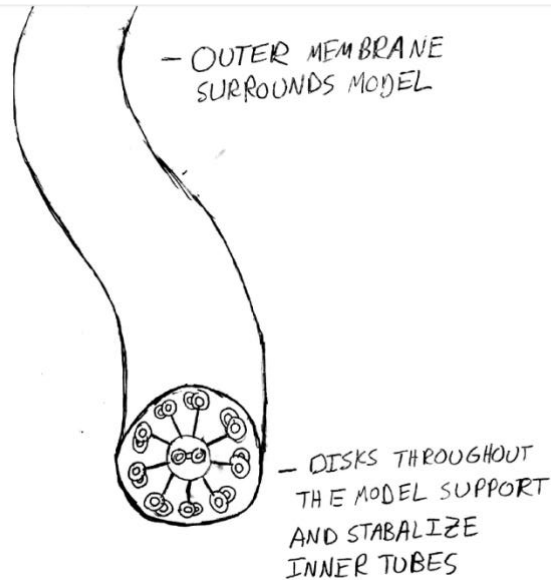

Figure 9: Spaghetti Model

Description: Thin rods in sets of two make up nine doublets around a single doublet in the middle. Spacers are placed along the model. These spacers have small holes for the thin rods to fit through. The radius of the spacers becomes slightly smaller as the flagellum tapers, and the spacers must also be flexible enough to allow for oscillatory motion.

Solutions:

1. Dynamic instability
2. Radial spokes and doublets
3. Membrane filling in space between tubes
4. Enclosed tank
5. Attached at 3 points at the top of model

3.4 CONCEPT #2 – “MEMBRANE MODEL”**Figure 10: Membrane Model**

Description: An outer membrane surrounds the disks and tubes in order to ensure that the fluid does not flow in between the spaces in the model as it is tested. The inner structure is similar to that of the Spaghetti model, but the disks must attach to the outer membrane. The membrane must be thin and sensitive enough so that the tubes and disks react to the motion of the surrounding fluid.

Solutions:

1. Dynamic Instability
2. Solid Disk
3. Membrane attached on outside
4. Trough/Pool
5. Anchored in tank wall

3.5 CONCEPT #3 – “WHEEL MODEL”

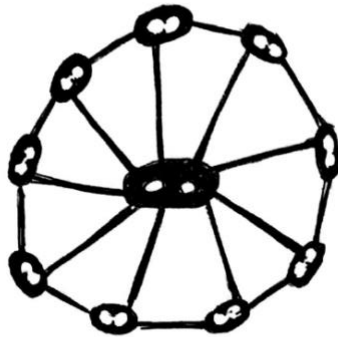

3D printed spacer intended
to mimic cross section
of cilium

Figure 11: Wheel Model

Description: Thin rods in doublets are placed around a single doublet in the center. The spacers are placed throughout the model to serve as a connection for the rods. In this design, the spacer has much less material than design one. It should have a small central piece that the center doublet goes through, and then spokes that connect the central piece to each of the outer doublets. This decrease in material in the spacer should make the model more flexible.

Solutions:

1. Follower force
2. Radial spoke
3. Membrane on outside
4. Enclosed Tank
5. Fix at 3 points on the top

3.6 CONCEPT #4 – “PUMP MODEL”

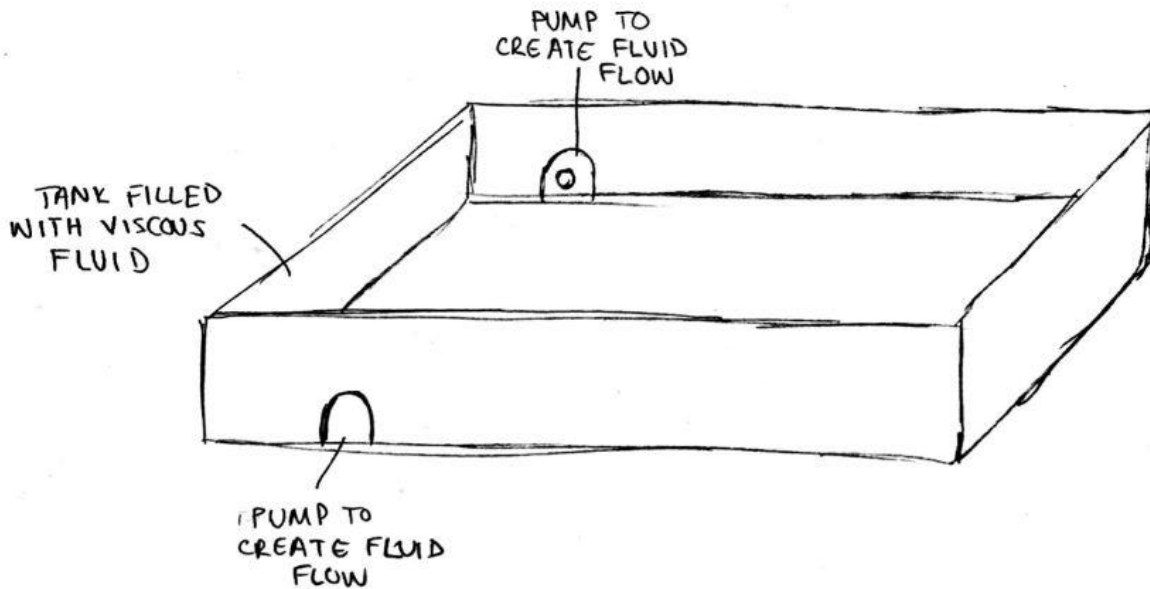

Figure 12: Pump Model

Description: A tub would be created to contain the viscous fluid that is chosen to mimic material properties. Two pumps would be mounted on the tub, one on either side. These pumps would be placed so that they create a current that causes the cilia to oscillate as it would in the body.

Solutions:

1. Depends on Model
2. Depends on Model
3. Depends on Model
4. Depends on Model
5. Trough/Pool
6. Fix end on tank wall

3.7 CONCEPT #5 – “POOL FLOAT MODEL”

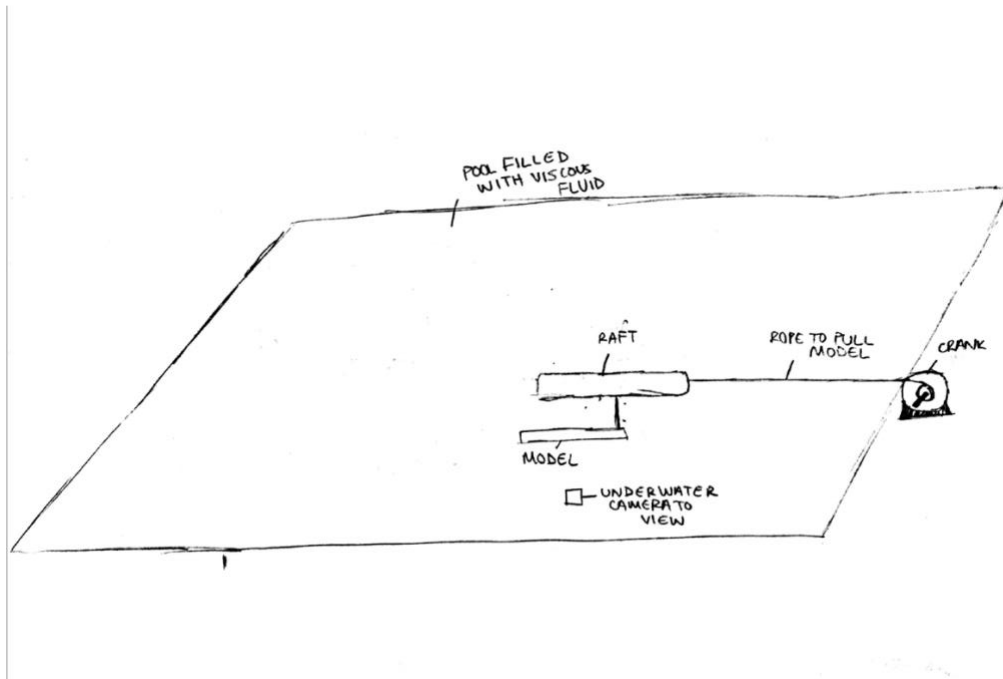

Figure 13: Pool Float Model

Description: The testing environment would be a pool. In order to create the oscillatory motion, the model would be dragged through the pool. This would be achieved by placing the model underwater and attaching it to a float. The float could then be pulled through the water by a crank placed on the pool deck. This dragging motion would create the oscillations in the model. An underwater camera would be placed in the pool to capture a video of the motion.

Solutions:

1. Depends on Model
2. Depends on Model
3. Depends on Model
4. Depends on Model
5. Trough/Pool
6. Fix end with Floatation Device

3.8 CONCEPT #6 – “VERTICAL TANK”

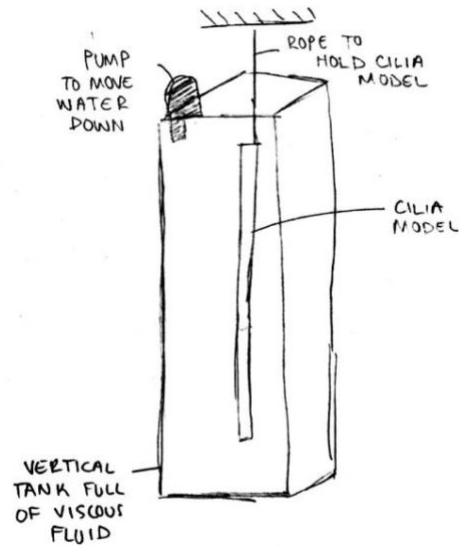

Figure 14: Vertical Tank

Description: A tub would be created to contain the viscous fluid that is chosen to mimic material properties. One pump would be mounted on the top of the tub and would move the fluid parallel to the cilia, also positioned vertically in the tank. The cilia cannot be buoyant so that its performance is not dependent on its position in the fluid.

Solutions:

1. Depends on Model
2. Depends on Model
3. Depends on Model
4. Depends on Model
5. Enclosed Tank
6. Attach at 3 points on top

4 CONCEPT SELECTION

4.1 CONCEPT SCORING MATRIX

		Alternative Design Concepts Model					
Selection Criterion	Weight (%)	Rating	Weighted	Rating	Weighted	Rating	Weighted
Water Proof	13.38%	3	0.40	3	0.40	3	0.40
Correct Bending Stiffness	18.79%	3	0.56	5	0.94	1	0.19
Reactive System	5.07%	3	0.15	3	0.15	2	0.10
Achieves Oscillation	9.83%	3	0.29	5	0.49	3	0.29
Proper Interfacing with Fluid	10.69%	3	0.32	5	0.53	1	0.11
Anatomically Correct	20.39%	3	0.61	5	1.02	1	0.20
Durability in Testing	6.16%	3	0.18	3	0.18	3	0.18
Usability / Anchoring in Testing	6.08%	3	0.18	1	0.06	3	0.18
Ease of Construction	2.53%	3	0.08	1	0.03	3	0.08
Cost of Components	1.31%	3	0.04	1	0.01	3	0.04
Mechanical Safety	5.78%	3	0.17	3	0.17	3	0.17
Total score		3.000		3.996		1.952	
Rank		2		1		3	

Figure 15: Model Weighted Scoring Matrix

	Water Proof	Correct Bending Stiffness	Reactive System	Achieves Oscillation	Proper Interfacing with Fluid	Anatomically Correct	Durability in Testing	Usability / Anchoring in Testing	Ease of Construction	Cost of Components	Mechanical Safety	Row Total	Weight Value	Weight (%)
Water Proof	1.00	0.33	3.00	5.00	3.00	0.14	5.00	5.00	3.00	7.00	1.00	33.48	0.13	13.38%
Correct Bending Stiffness	3.00	1.00	7.00	5.00	5.00	1.00	3.00	7.00	5.00	5.00	5.00	47.00	0.19	18.79%
Reactive System	0.33	0.14	1.00	1.00	0.33	0.20	0.33	0.33	3.00	3.00	3.00	12.68	0.05	5.07%
Achieves Oscillation	0.20	0.20	1.00	1.00	1.00	0.20	3.00	3.00	5.00	5.00	5.00	24.60	0.10	9.83%
Proper Interfacing with Fluid	0.33	0.20	3.00	1.00	1.00	0.20	3.00	3.00	5.00	5.00	5.00	26.73	0.11	10.69%
Anatomically Correct	7.00	1.00	5.00	5.00	5.00	1.00	5.00	5.00	5.00	7.00	5.00	51.00	0.20	20.39%
Durability in Testing	0.20	0.33	3.00	0.33	0.33	0.20	1.00	1.00	3.00	3.00	3.00	15.40	0.06	6.16%
Usability / Anchoring in Testing	0.20	0.14	3.00	0.33	0.33	0.20	1.00	1.00	3.00	5.00	1.00	15.21	0.06	6.08%
Ease of Construction	0.33	0.20	0.33	0.20	0.20	0.20	0.33	0.33	1.00	3.00	0.20	6.33	0.03	2.53%
Cost of Components	0.14	0.20	0.33	0.20	0.20	0.14	0.33	0.20	0.33	1.00	0.20	3.29	0.01	1.31%
Mechanical Safety	1.00	0.20	0.33	0.20	0.20	0.20	0.33	1.00	5.00	5.00	1.00	14.47	0.06	5.78%
Column Total:												250.18	1.00	100%

Figure 16: Model Analytic Hierarchy Process

		Alternative Design Concepts Testing Environment					
Selection Criterion	Weight (%)	Rating	Weighted	Rating	Weighted	Rating	Weighted
Mechanical safety	4.622	1	0.05	3	0.14	1	0.05
Cost of components	1.481	3	0.04	5	0.07	3	0.04
Watertight	14.5	3	0.44	5	0.73	1	0.15
Ease of Assembly / Disassembly	19.8	3	0.59	5	0.99	1	0.20
Fits within a Reasonable Space	7.02	3	0.21	1	0.07	5	0.35
Ease of water & power hookup	4.62	3	0.14	5	0.23	3	0.14
Weight of Structure	4.88	3	0.15	1	0.05	3	0.15
Fluid flow is perpendicular to model	16.8	3	0.50	3	0.50	3	0.50
Constant velocity of fluid flow	18	3	0.54	3	0.54	3	0.54
Closed Testing Environment	8.5	3	0.26	3	0.26	3	0.26
Total score		2.914		3.577		2.369	
Rank		2		1		3	

Figure 17: Environment Weighted Scoring Matrix

	Mechanical Safety	Cost of components	Watertight	Ease of Assembly / Disassembly	Fits within a reasonable space	ease of water & power hookup	Weight of Structure	Fluid flow is perpendicular to model	Constant velocity of fluid flow	Closed Testing Environment	Row Total	Weight Value	Weight (%)
Mechanical safety	1.00	5.00	0.14	0.20	1.00	1.00	0.33	0.20	0.14	0.33	9.35	0.05	4.62%
Cost of components	0.20	1.00	0.20	0.11	0.20	0.33	0.33	0.14	0.14	0.33	3.00	0.01	1.48%
Watertight	7.00	5.00	1.00	0.33	3.00	5.00	3.00	1.00	1.00	3.00	29.33	0.14	14.50%
Ease of Assembly / Disassembly	5.00	9.00	3.00	1.00	7.00	3.00	5.00	1.00	1.00	5.00	40.00	0.20	19.77%
Fits within a Reasonable Space	1.00	5.00	0.33	0.14	1.00	3.00	3.00	0.20	0.20	0.33	14.21	0.07	7.02%
Ease of water & power hookup	1.00	3.00	0.20	0.33	0.33	1.00	3.00	0.14	0.14	0.20	9.35	0.05	4.62%
Weight of Structure	3.00	3.00	0.33	0.20	0.33	0.33	1.00	0.33	0.33	1.00	9.87	0.05	4.88%
Fluid flow is perpendicular to	5.00	7.00	1.00	1.00	5.00	7.00	3.00	1.00	1.00	3.00	34.00	0.17	16.81%
Constant Velocity of fluid flow	7.00	7.00	1.00	1.00	5.00	7.00	3.00	1.00	1.00	3.00	36.00	0.18	17.79%
Closed Testing Environment	3.00	3.00	0.33	0.20	3.00	5.00	1.00	0.33	1.00	1.00	17.20	0.09	8.50%
Column Total:											202.31	1.00	100%

Figure 18: Environment Analytic Hierarchy Process

4.2 EXPLANATION OF WINNING CONCEPT SCORES

Pool Environment & Membrane Model

The pool environment and the membrane model scored first place in scoring matrix that we created. The pool model is by far the most practical model. After researching methods to buy or create a tank large enough to use either the vertical or horizontal model our team realized that would not be possible. Additionally, the pool model will ensure water-tightness and perpendicular flow, the second and third most important criteria. The membrane model is by far the most effective model of the cilia. Most importantly, we believe that it will correctly mimic the actual anatomy and bending stiffness of the appendage more accurately than other models. Though it is more complicated and costly to construct, it will also provide the most realistic interface between the model and the testing fluid. This is very important because a major objective of our project is to be able to perform accurate tests on the cilia model.

4.3 EXPLANATION OF SECOND-PLACE CONCEPT SCORES FOR ENVIRONMENT

Horizontal Tank

The horizontal take came in second for the environment design. Other than the orientation, there is not a large differentiation between this design and the vertical tank. However, the horizontal orientation would likely allow for slightly easier assembly as materials could more easily be purchased. Additionally, this model would likely be easier to make water tight. This model is significantly less effective than the place pool design though. It is outclassed in every category except for weight and space requirements, two of the least important categories. Though possibly a better testing environment, due to the impracticality of purchasing materials for and building the horizontal tank, it came in second place to the pool model.

4.4 EXPLANATION OF SECOND-PLACE CONCEPT SCORES FOR MODEL

Bike-Wheel Model

The bike-wheel model scored second in the weighted scoring matrix. This model was not significantly better than the reference (spaghetti model) in any category. It would have a more accurate bending stiffness than the reference, because the spacers would be less stiff. Along those same lines, the bike-wheel model would be more anatomically correct than the reference because actual cilia have doublets connected by thin spokes. However, the membrane model would still be more correct as it would contain a membrane. Due to the small spacers, the bike-wheel model would be significantly worse when interfacing with the fluid. The reference would be slightly better with more surface area, and the membrane model would be best with a membrane covering the entire body. Thus, the bike-wheel model would not be as much of a reactive system because it would not interface with the fluid as well as the other models. In all other categories, the bike-wheel model is as good as the reference. It should be fairly easy to construct, have a low cost, be waterproof, and oscillate. It is a better model than the reference, but not quite as good as the membrane model.

4.5 SUMMARY OF EVALUATION RESULTS

For our cilia model, it was deemed most important that the model be anatomically correct, due to the fact that the model is to be used for understanding the biology of cilia in the human body. The second most important criteria was that the model is waterproof, since the other half of our project involves putting the model in water to observe the oscillations. The least important criteria for the cilia model was the cost of components, because our budget is fairly large and the components are not expensive. Based on the criteria in the hierarchy process in section 4.1, the membrane model was the best option, followed by the spaghetti model, then the wheel model. The membrane model would be the most waterproof, as well as the version most likely to respond well to the movement of the water to create oscillations.

For our environmental model, the most important criteria was the ease of assembly/disassembly, since the environment would be large and would ideally be portable to make it easy to demonstrate in offices or

conferences. The second most important criteria was have a constant fluid flow velocity, followed closely by perpendicular fluid flow to the model. The details of fluid flow allow the cilia to oscillate, which is why they were ranked so highly. In contrast, the least important criteria was the cost of the components for the same reason as the cilia model itself. Based on this criteria, the pool model was first, followed by the horizontal tank and then the vertical tank. The pool model was the best based on the size of the cilia model, as tanks large enough to hold the model cannot be bought and would need to be large and very difficult to move.

After the completion of this analysis, we will be perusing the anatomically correct membrane model and the pool testing environment. We believe that these choices will allow us to create a product that will best satisfy our customer, Dr. Bayly. With this in mind we will review our choice with Dr. Bayly, make adjustments if necessary, and then begin ordering parts.

5 EMBODIMENT & FABRICATION PLAN

5.1 ISOMETRIC DRAWING WITH BILL OF MATERIALS

See next page

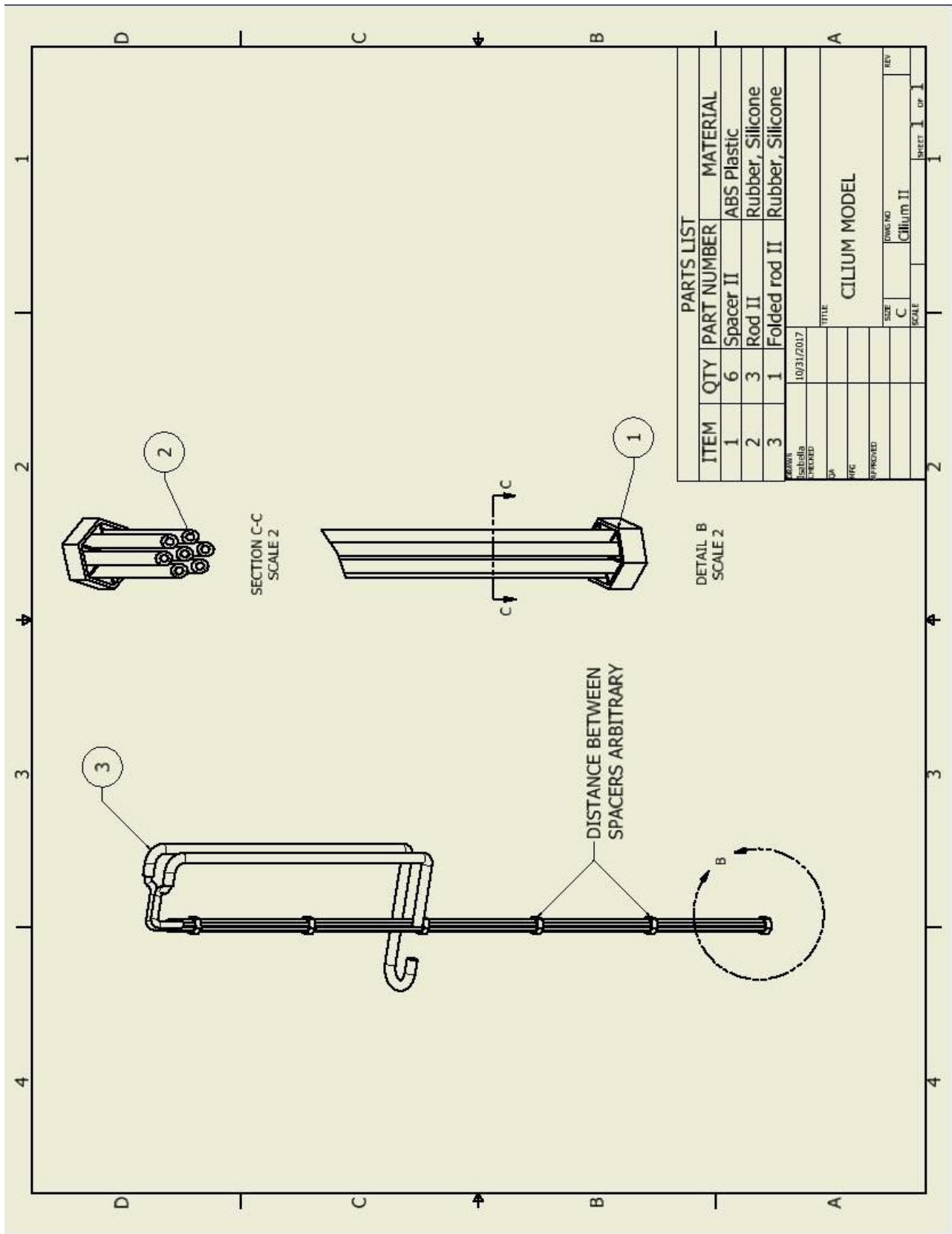

Figure 19: Isometric Drawing of Cilium Model with Bill of Materials

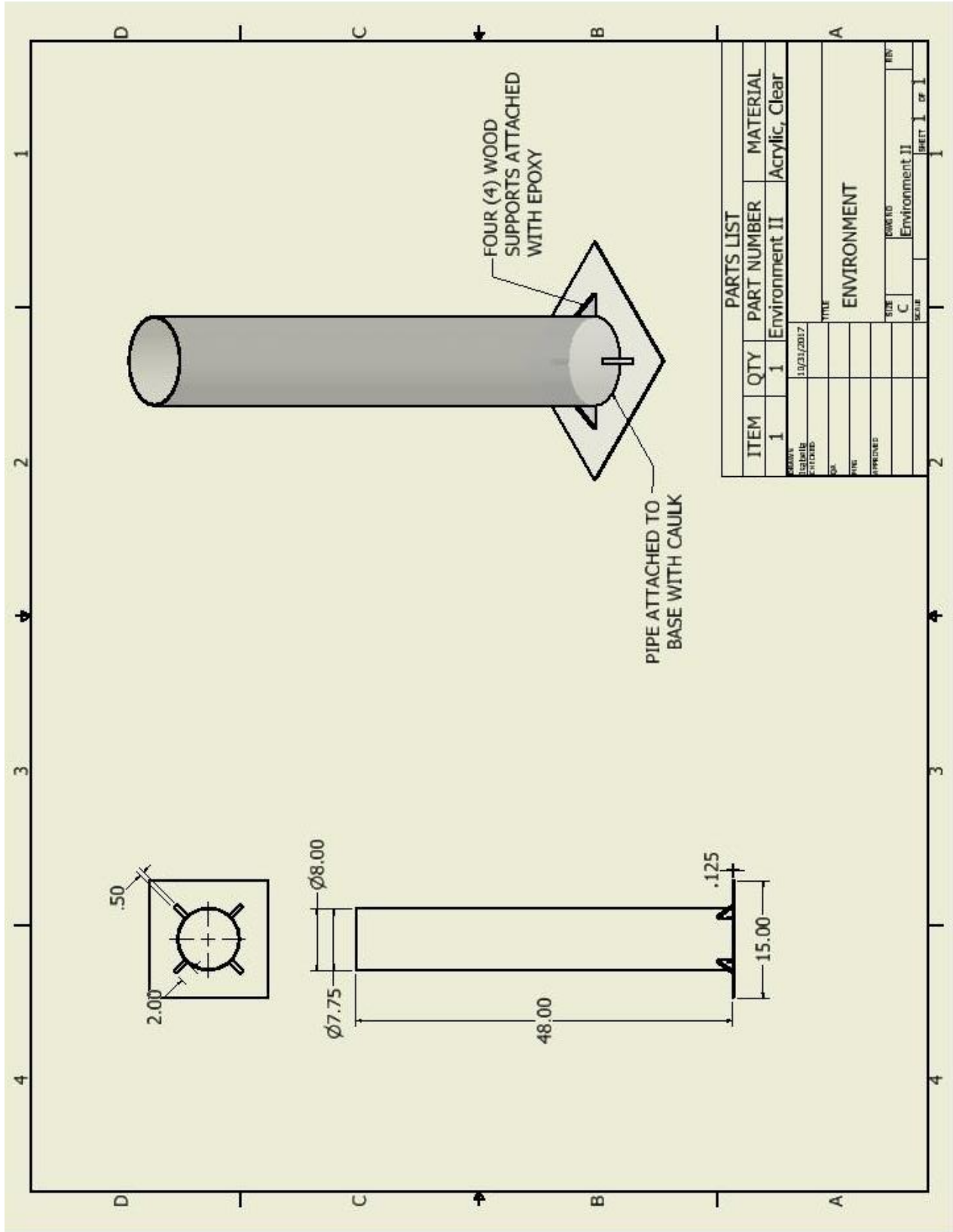

Figure 20: Isometric Drawing of Environment with Bill of Materials

5.2 EXPLODED VIEW

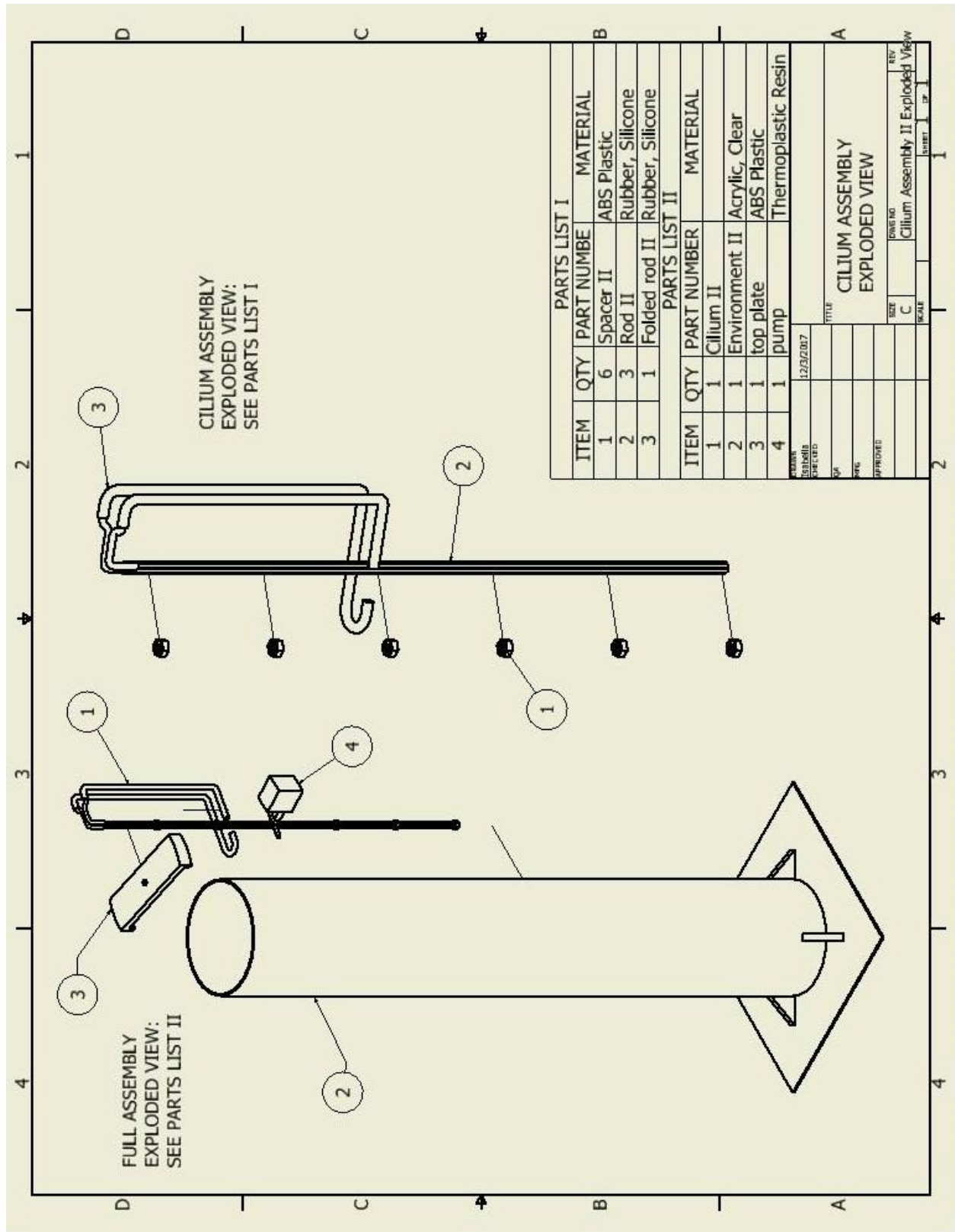

Figure 21: Exploded View of Cilium Assembly

5.3 ADDITIONAL VIEWS

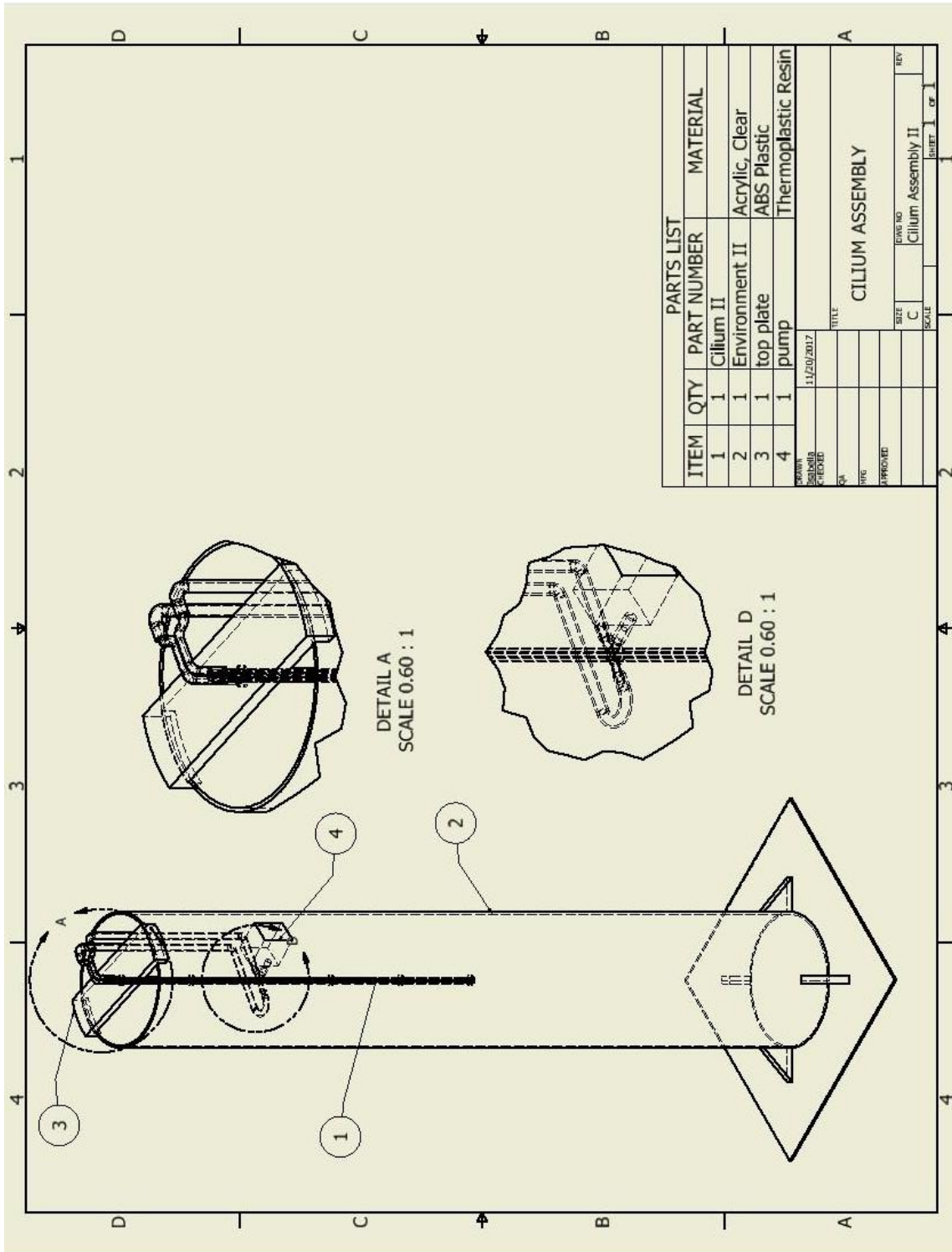

Figure 22: Cilium Assembly CAD Model

6 ENGINEERING ANALYSIS

6.1 ENGINEERING ANALYSIS RESULTS

6.1.1 Motivation

The first standard for our project is 29 CFR 1910, a safety code that documents preventing spillage from water tanks in order to protect employees. The second code, ASTM E715 - 80, is a code that documents having uniform temperatures when using liquids in experimentation in order to ensure accuracy. Our engineering analysis will be focused on 3 hand calculations. Our first calculation will determine the dimensions of the silicon tubes to mimic the correct mechanical properties. Next, we will determine the force flowing through the tubes necessary to theoretically achieve dynamic instability. Lastly, we will calculate the Reynold's number to verify laminar or turbulent flow. Determining these three values will allow us to more effectively model the cilium appendage, correctly design and create our model, and ensure that our testing environment will be able to create the force that would theoretically create dynamic instability. Finally, verifying the type of flow will allow us to ensure the accuracy of our calculations.

6.1.2 Summary Statement of the Analysis

Below are the calculations we performed in order to determine the dimensions of the tubes, the required force, and the Reynold's number for our project. In our first set of calculations we determined the necessary length for our model which depended on achieving the correct bending stiffness and maintaining the aspect ratio of the actual cilia. For this calculation we used equations for moment of inertia and a simplified length equation based on the dynamic scaling Dr. Bayly assisted us with. These equations, and the full calculation are displayed below. Next, we calculated the force required in the tubing using an equation for force per unit length, a force and shear stress relation, the Colebrook turbulent flow approximation, the equation for the Reynold's number, and an equation for flow rate. These calculations and equations are also displayed in the graphic below. Lastly, we calculated the Reynold's number by using a flow rate, the density, viscosity, diameter, and a Reynold's number equation as shown below.

Length of Model Calculations

Equation 1 below shows the dimensionless parameter found by Dr. Bayly that was used to determine the scaled up properties of our model.

$$\alpha = \frac{\mu L^4}{TEI} \quad (1)$$

Table 5 shows the mechanical properties of the microscale and macroscale cilia.

Variable	Parameter	Microscale	Macroscale
μ	Viscosity	0.001 Ns/m ²	0.001 Ns/m ²
EI	Bending Stiffness	800*10 ²⁴ Nm ²	See calcs below
L	Length of Tube	10 ⁻⁵ m	?
T	Period	0.01 s	1 s

Table 5: Micro and Macro Scale Mechanical Properties of Cilia

Using equation 1, we found α for the cilia, which is equal to α for the model.

$$\alpha_{cilia} = \frac{0.001 * (10^{-5})^4}{0.01 * 800 * 10^{-24}} = 1.25 = \alpha_{model}$$

The tubes we chose to make the model are silicone rubber, which has the following properties:

Tube size: outer diameter = $d_o = 0.125$ in = 0.003175 m, inner diameter = $d_i = 0.0625$ in = 0.0015875 m

From the tube size, we were able to use equation 2 to find the moment of inertia (I) for each individual tube.

$$I = \frac{\pi}{64} (d_o^4 - d_i^4) = 4.6764 * 10^{-12} m^4 \quad (2)$$

Silicone rubber has a Young's modulus of $E = 0.005 * 10^9$ N/m².⁵ Based on this information, we can rearrange equation 1 to get the following:

$$\alpha_{model} = \frac{0.001 * (L)^4}{1 * EI} = 1.25 = \alpha_{cilia}$$

Therefore we can determine the equation 3, which helps us determine the necessary length of the tubes:

$$(EI)_{total} = \frac{L^4}{1250} \quad (3)$$

Since our design is using 7 tubes to stand in for the 7 doublets in an actual cilia, we can then determine the individual EI needed by dividing Eq. 3 by 7.

$$(EI)_{individual} = \frac{L^4}{1250 * 7} = 1.14 * 10^{-4} * L^4$$

Using Eq. 2, Young's modulus for silicone rubber, and our simplified Eq. 3 we can now solve for length:

$$L = \left(\frac{.005 * 10^9 * (4.6764 * 10^{-12})}{1.14 * 10^{-4}} \right)^{1/4} = 0.67 m = 2.19 ft$$

Force Per Unit Length Through Tube:

In a similar method as the one to calculate the length of the model, Dr. Bayly provided a dimensionless parameter F_o that could be used to scale up the force per unit length as shown in equation 4.

$$F_o = \frac{f * L * D^2}{EI} \quad (4)$$

Table 6 shows the micro and macro scale properties of cilia used to calculate the force per unit length.

Variable	Parameter	Microscale	Macroscale
f	Force	$400 * 10^{-12}$ N / $1 * 10^{-6}$ m	?
EI	Bending Stiffness	$800 * 10^{-24}$ Nm ²	$2.3382 * 10^{-5}$ Nm ²
D	Inner Diameter of Tube	$0.2 * 10^{-6}$ m	0.0015875 m
L	Length of Tube	$12 * 10^{-6}$ m	0.67 m

Table 6: Properties of Cilia and Model Used to Calculate Force

Thus we can solve Eq. 4 for F_o :

$$F_o = \frac{f * L * D^2}{EI} = \frac{400 * 10^{-12}}{1 * 10^{-6}} * \frac{12 * 10^{-6} * 0.2 * 10^{-6}^2}{800 * 10^{-24}} = 0.24$$

Then we can use equation 5 to find the force per unit length for the scaled up model.

$$f_{model} = \frac{F_o * EI_o}{L_o D_o^2} = \frac{0.24 * 2.3382 * 10^{-5}}{0.67 * 0.0015875^2} = 3.32 \frac{N}{m} \quad (5)$$

Flow Rate Needed to Achieve Force:

Given the force per unit length that our model needed to achieve, we could then find out what flow rate and velocity would create that force in the tube. We related the force per unit length to the shear stress using equation 7.

$$F = \int \tau_w A = \tau_w (2 * \pi * r * l) \rightarrow \frac{F}{l} = f_{model} = \tau_w (2 * \pi * r) \quad (6)$$

Solving Eq. 7 led to a shear stress of 665 N/m² as shown below.

$$3.32 = \tau_w \left(2 * \pi * \frac{0.0051875}{2} \right) \rightarrow \tau_w = 665.69 \frac{N}{m^2}$$

We then solved the system assuming first turbulent flow, then laminar flow and used the Reynold's number to justify our assumptions.

Assume turbulent flow:

For turbulent flow, there is not a simple equation that relates shear stress and flow rate. Thus we used the Colebrook equation to find the friction factor along with the Reynold's number to calculate the velocity of the fluid. Equation 7 shows the Colebrook equation.

$$\frac{1}{\sqrt{f}} = -2 * \log \left(\frac{\frac{\varepsilon}{D}}{3.7} + \frac{2.51}{Re * \sqrt{f}} \right) \quad (7)$$

In the above equation, f is the friction factor and ε is the surface roughness, which is 0.038 mm for silicone rubber. In addition, the density of water is 1000 kg/m³. First, you need to find the Reynold's number, which is described by Equation 8.

$$Re = \frac{\rho * V * l}{\mu} \quad (8)$$

Solving Eq. 8 for turbulent flow gives the following correlation. It should be noted that l in Eq. 8 is the diameter of the tube.

$$Re = \frac{\rho * V * l}{\mu} = \frac{1000 * V * 0.0015875}{0.001} = 1587.5 * V$$

The friction factor, f is also needed to solve the Colebrook equation, and is given by equation 9.

$$f = \frac{8\tau_w}{\rho V^2} \quad (9)$$

In our case, the friction factor can be reduced to the following:

$$f = \frac{8 * \tau_w}{\rho * V^2} = \frac{8 * 665.69}{1000 * V^2} = \frac{5.325}{V^2}$$

By plugging in the correlations for the Reynold's number and the friction factor into the Colebrook equation, the velocity is found to be 9.901 m/s. Given this velocity, the flow rate can be found using equation 10.

$$Q = V * A \quad (10)$$

Thus plugging in for the velocity and the area, we found a flow rate of 18.6 gph as shown below:

$$Q = 9.9 * \pi * \left(\frac{0.0015875}{2}\right)^2 = 1.9595 * 10^{-5} \frac{m^3}{s} = 18.6 \text{ gph}$$

The corresponding Reynold's number is 15,717.8 which corresponds to turbulent flow, thus our assumption of turbulent flow is correct. The calculation for the Reynold's number is shown below.

$$Re = 1587.5 * V = 1587.5 * 9.901 = 15717.8$$

Assume laminar flow:

To double check that our assumption of turbulent flow was correct, we ran through the same calculations for laminar flow. Equation 11 shows the equation for shear stress with laminar flow.

$$\tau_w = \frac{\Delta P * D}{4 * l} \quad (11)$$

Equation 12 shows the equation for flow rate with laminar flow.

$$Q = \frac{\pi * D^4 * \Delta P}{128 * \mu * l} \quad (12)$$

This equation can be rearranged to solve for ΔP , which gives the following result:

$$\Delta P = \frac{128 * Q * \mu * l}{\pi * D^4}$$

Thus we can plug ΔP into the τ_w equation to find the relationship given in equation 13.

$$\tau_w = \frac{128 * Q * \mu * l * D}{4 * \pi * D^4 * l} = \frac{32 * Q * \mu}{\pi * D^3} \quad (13)$$

Given that we know the shear stress is 665 N/m², we can solve Eq. 13 for the flow rate, Q.

$$665.69 = \frac{32 * Q * 0.001}{\pi * 0.0015875^3} \rightarrow Q = 2.6146 * 10^{-4} \frac{m^3}{s} = 248.65 \text{ gph}$$

By rearranging Eq. 10 we can solve for the necessary velocity, which we find to be 132.09 m/s as shown below:

$$V = \frac{Q}{A} = \frac{2.6146 * 10^{-4}}{\pi * \left(\frac{0.0015875}{2}\right)^2} = 132.09 \frac{m}{s}$$

Finally, we can solve for the Reynold's number using Eq. 8 to verify that it is in fact laminar flow.

$$Re = \frac{\rho * V * l}{\mu} = \frac{1000 * 132.09 * 0.0015875}{0.001} = 209,682$$

Since $Re > 2100$, we can see that the flow is in fact not laminar, and thus our assumption of turbulent flow is correct. Figure 20 shows a schematic of the individual tubes, with dimensions. Drawing is not to scale.

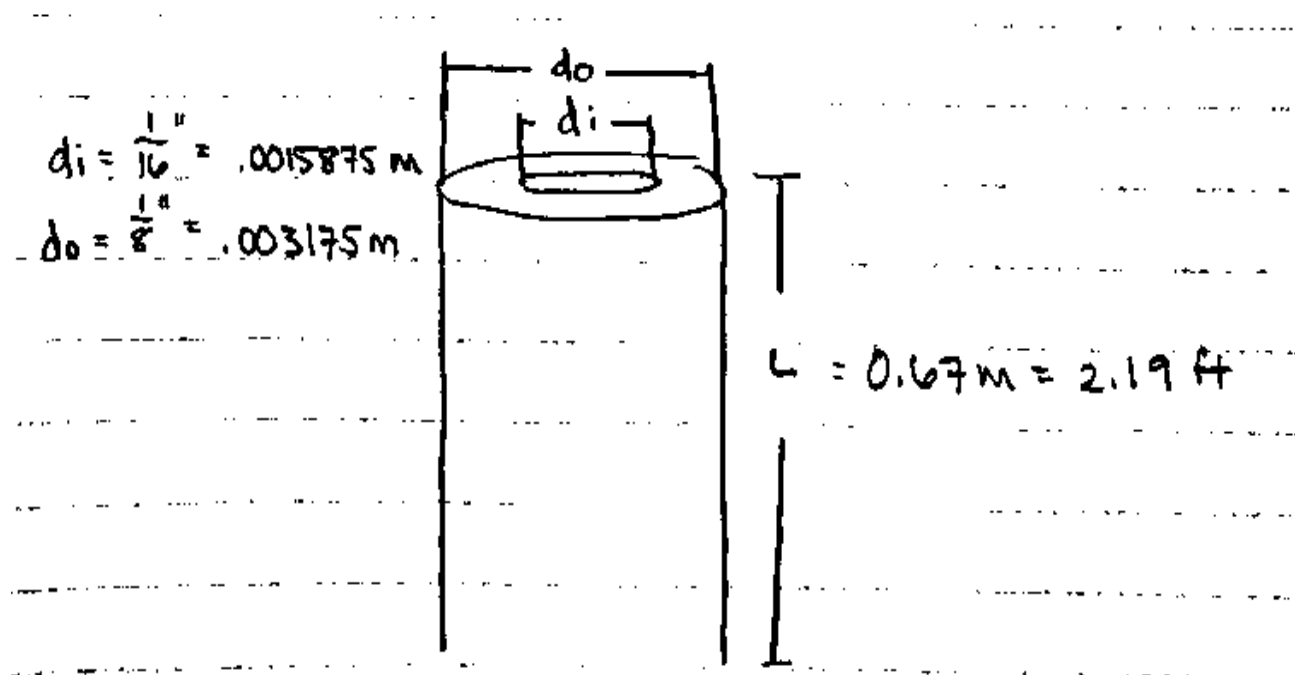

Figure 23: Schematic of tubes with dimensions

6.1.3 Methodology

Our analysis did not require any experimentation or testing rigs but rather a lot of algebra. In order to perform the necessary calculations we began by researching cilia organelles. To start, we read extensively on dynamic scaling and fluid mechanics both online and in textbooks Dr. Bayly provided us. For the most part, we had never worked with dynamic scaling or this type of fluid mechanics in our coursework. As a result, we spent a good amount of time understanding how to best perform these calculations. After

performing our initial research, we did our first round of calculations and verified them with Dr. Bayly. We continued to refine our calculations with him until our properties correctly replicated those of cilia. In addition to our meetings with Dr. Bayly, we also met with Dr. Boyd. In this meeting we further discussed our fluid calculations and how to best create our model to mimic the theoretical dynamic instability.

6.1.4 Results

Our first calculation, for tube size, resulted in a length of 2.19 ft. This is a reasonable number and is well within our targeted length range. It maintains the correct 1:50 aspect ratio and should also allow any theoretical oscillations to be observable due to its size. Next, our calculations revealed that the force necessary to achieve the theoretical dynamic instability is about 3.32 N/m. This is also a reasonable number. It is very small, but our model also uses tubing that is only 3mm in diameter. Working with such small materials makes this small force reasonable. Additionally, the calculated force lead us to a fluid flow velocity of 9.9 m/s and a flow rate [Q] of 18.6 gph, both numbers that we have approved with Dr. Bayly. Lastly, our calculations revealed that our model will have turbulent flow because the Reynold's number was 15,718. A large Reynold's number and turbulent flow also make sense given the conversations that we had with Dr. Boyd and the small diameter of the tubes we are using.

6.1.5 Significance

On the following pages are CAD drawings for before and after our engineering analysis and a summary of the changes we made as a result of this analysis.

Before:

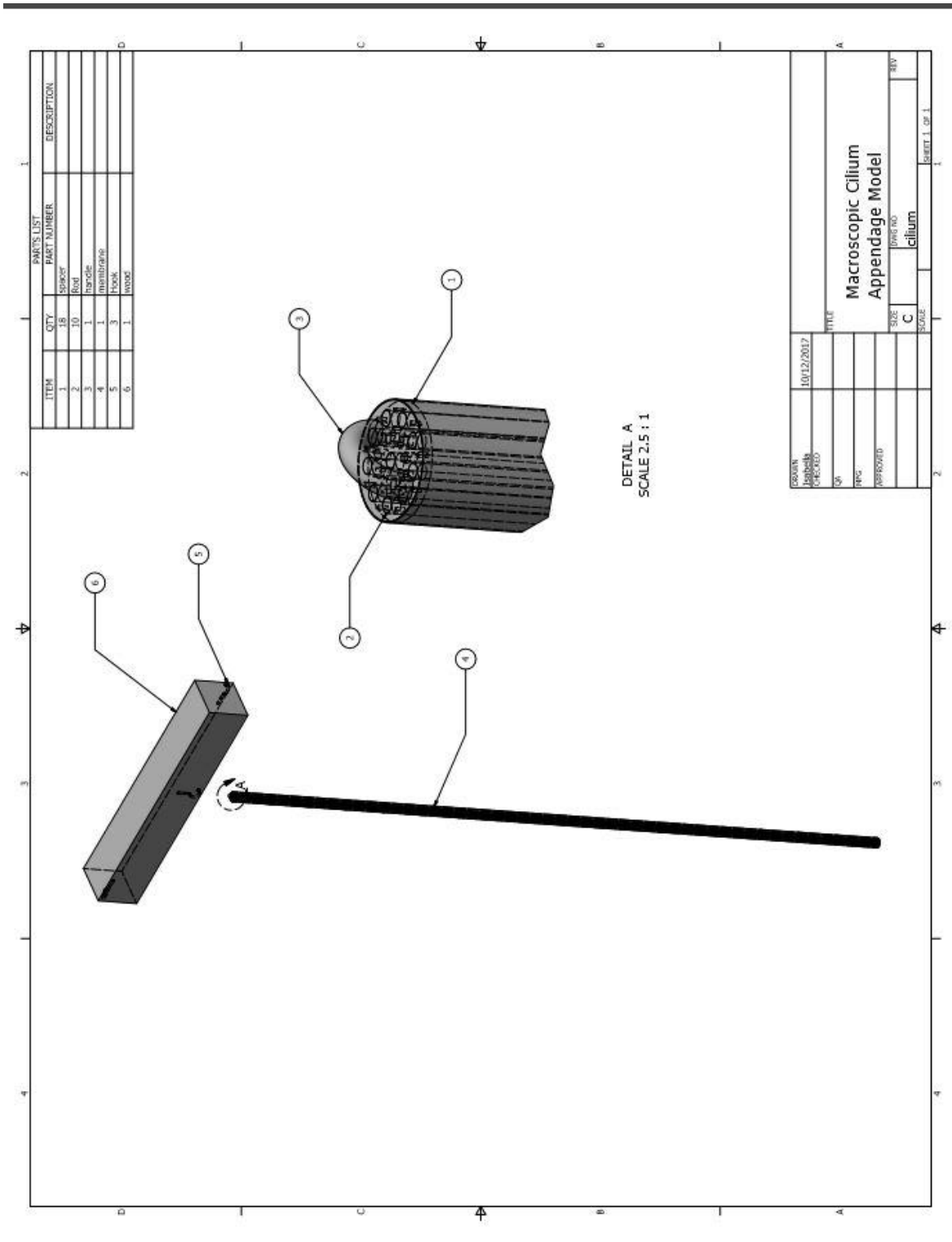

Figure 24: Original CAD drawing of the macroscopic cilium appendage model

After:

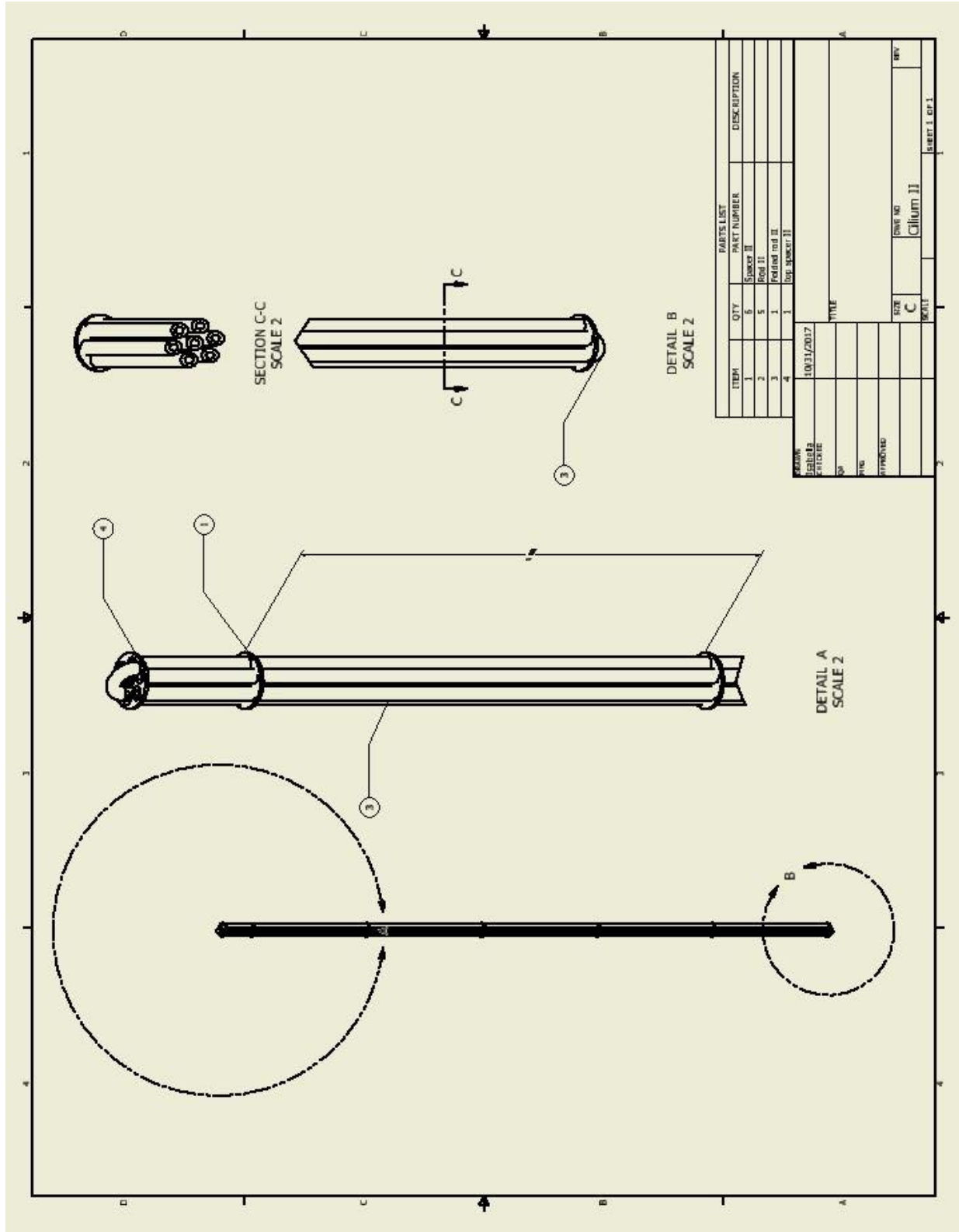

Figure 25: Current CAD drawing of the macroscopic cilium appendage model

Our engineering analysis did not support our current design and forced us to make some fairly significant changes to our model. Perhaps most significantly, we decided to remove the outer casing, shown in Detail A of figure 21, above, from our model. After determining that it was possible to achieve the necessary force by pushing fluid through the tubes, thus creating a closed system, we elected to pursue this option in order to more effectively meet our customer's needs. Additionally, we had to change the length of our model and the tubing material after performing our calculations. Thankfully though, it is now just over 2 feet long and will easily be created using silicon rubber. However, along with this length came a significant drop in the total radius of our model. This means that our spacers will have to be very small which in our initial drafts has made them difficult to 3D print. In summary, the casing was removed from our model and changes were made to the dimensions of our model as well as the tubing material used after performing our calculations.

6.2 PRODUCT RISK ASSESSMENT

6.2.1 Risk Identification

Risk Name: Risk of Spillage

Description: Because we are working with water, there is always a risk of spillage. Ideally, the pump connection to the tubing will be a closed system, so this should pose a relatively low risk of leakage. However, our environment will be a 10-inch pipe, about 3 feet tall, and filled up most of the way with water. The base that will be attached to it will have a slightly larger diameter, but there is still a risk that the environment will get bumped into and tip over and spill a lot of water.

Impact = 3: Leakage from the pump system would have a low impact, no more than the amount that can be cleaned up by one standard paper towel. However, if the entire environment full of water were to tip over, the amount of water would be significant. Depending on the space in which the environment is spilled, a variety of things such as equipment could be harmed.

Likelihood = 2: A large spill is fairly unlikely to occur. The environment would be filled with water, which is heavy, and the base should be large enough to withstand a fair amount of force. The pump could potentially set the environment off balance, but overall it should be fairly stable. Leakage from the pump system is more likely to occur.

Risk Name: Risk of Pump Overheating

Description: If the pump is used improperly or for an extended period of time, it runs the risk of overheating. This has the potential to affect the entire system by damaging the tubing or breaking the pump. An overheated pump could also be hot to the touch, so there is a potential for burns.

Impact = 4: Overheating of the pump could cause some aspects of the model to be unusable. If the pump overheats for too long, it can break, so we would have to buy a new pump. It could also potentially burn or melt the parts of the cilium and environment that come into contact with it.

Likelihood = 1: If we are careful with our use of the pump and monitor it while it is running, the pump should not overheat. This situation is very unlikely.

Risk Name: Risk of Injury on Sharp Edges

Description: We are going to have to cut the pipe for the environment to length. The base portion of the environment will also need to be a square. The pipe has the potential to be sharp at the top edge as well as at the corners of the base plate. In addition, the pump may also have some sharp portions. These all pose a risk of minor cuts.

Impact = 2: Any cut that could result from this system should be fairly easy to bandage and should not take a great amount of time to heal.

Likelihood = 1: As long as we are careful around the system and wear closed-toed shoes to prevent injury on the base plate, we should not sustain any cuts from the assembly.

Risk Name: Risk of Shattering

Description: Ideally, Dr. Bayly would be able to take this model with him to conferences and such, so it will need to be subjected to some travel. Being checked onto a plane is risky because it could be thrown or damaged during the flight. If the plexiglass of the environment were to shatter, it would be expensive, difficult to clean up, and also pose a minor threat of injury.

Impact = 5: If the environment were to shatter, it would be very expensive to replace. It would also potentially create shards of plexiglass that would be sharp, as well as small pieces which could be messy.

Likelihood = 3: If the cilium and environment were to be taken on a plane, they would have to be extremely well-packed in order to withstand the journey. If care was not taken to pack them properly, the risk of shattering would be fairly likely.

Risk Name: Risks Associated with Epoxy

Description: During the building portion of the project, we will be working with epoxy. This has a couple of risks associated with it, including accidental bonding of materials and chemical ingestion concerns.

While we are bonding components using epoxy, we need to take care so that we don't accidentally bond fingers or other parts of the model that should not be bonded. Epoxy is meant to be a permanent bond, so this could result in setbacks while we have to order new parts or injury if fingers are bonded together.

Additionally, if a child or animal were to drink the water that fills the tank, the water could have small amounts of epoxy or other chemicals from the tubing dissolved in it, which could also pose a health risk.

Impact = 4: The potential setbacks and health issues associated with epoxy are concerning. We cannot afford to lose more time in our schedule, and any kind of medical situation would be a setback as well.

Likelihood = 2: We will need to take time so that proper safety precautions are taken while we are using the epoxy. However, any carelessness during that process could result in accidental bonding. It is also unlikely that children or animals would be near the assembly and that they would drink the water.

Risk Name: Choking Hazards

Description: The various components of the model could potentially be dangerous for children and pets to be around. The spacers are very small (about 1/2" in diameter) and the tubes are long and thin. The cilium itself is also long and thin. The spacers could be easily swallowed and could cause choking, and the tubes or the cilium could become entangled around an individual so that they would choke.

Impact = 3: It would be very scary if a child were to choke on one of the components of the model, but children should not be near the model without any adults around to watch them. If a child were to get ahold of any of the components, an adult should be nearby and able to untangle or help the child out.

Likelihood = 1: This situation is very unlikely. Children should not be near the cilium model without the presence of adults.

6.2.2 Risk Heat Map

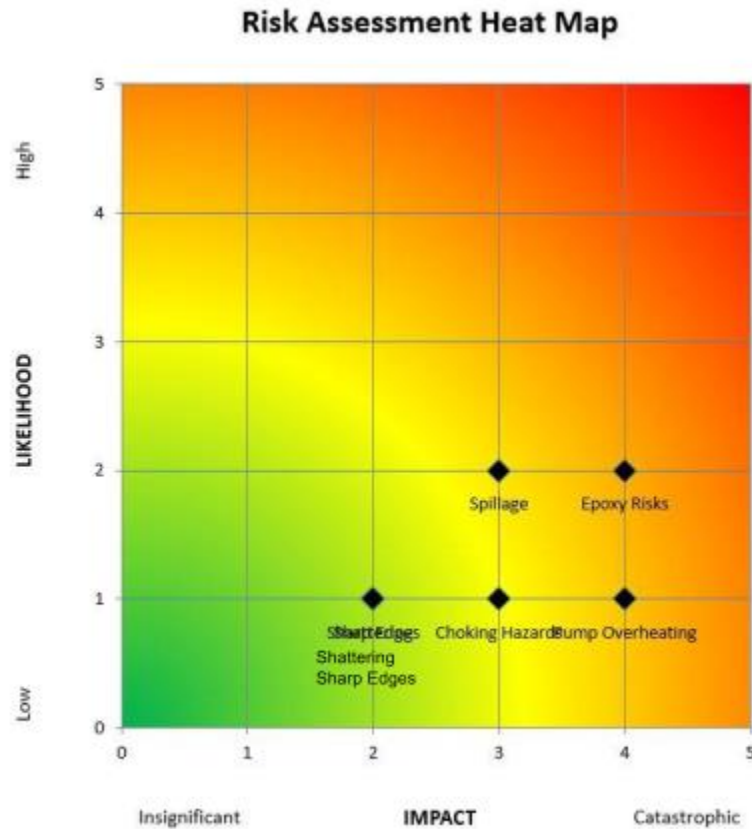

Figure 26: Heat map for various risks

6.2.3 Risk Prioritization

The heat map above displays how likely and dangerous each risk is. We can see that the two most likely risks are spillage and epoxy risks. Funny enough, these were the two risks that actually occurred. Due to an epoxy failure between the acrylic tube and acrylic base the water column broke and a large spillage occurred. As a result of this failure, we found a new method to seal the acrylic and now have a water tight system. Other identified risks included the pump overheating, choking hazards related to the 3D printed parts, and sharp edges. Each of these was unlikely to occur and none of them did. If the pump had overheated, one of the highest impact risks, we would have had to purchase another potentially putting us over budget. Overall, the risk prioritization was very accurate and successfully predicted some of the risks we faced.

7 DESIGN DOCUMENTATION

7.1 PERFORMANCE GOALS

- 1) The viscoelastic constant of the model will be within +/- 10% of the theoretical viscoelastic constant of cilia.
- 2) The model and testing environment will be watertight.
- 3) The model will exhibit proper bending stiffness within +/- 10% of the theoretical bending stiffness of cilia.
- 4) The model will sustain oscillation in response to fluid flow for at least 5 seconds.
- 5) After using the testing environment, any spillage will be able to be cleaned up by 1 standard paper towel.

7.2 WORKING PROTOTYPE DEMONSTRATION

7.2.1 Performance Evaluation

Although we were unable to successfully create oscillations, we were able to complete our other performance goals and go further to make significant progress for Dr. Bayly and his lab as they attempt to scale up the cilium appendage. First, through our calculations we were able to create a model which effectively modeled the theoretical bending stiffness and viscoelastic constant of the cilia. Additionally, we were able to create an effective seal for our environment which kept the system watertight and also created a closed system so that there was no spillage during testing.

Beyond our performance goals, we also were able to create a frictionless testing environment, improving upon previous designs that were limited by their inability to replicate the environment in the human body. This is important because the environment in which the model is tested largely impacts the performance of the model itself. In addition, we were able to create a portable model which Dr. Bayly can bring to presentations as he travels. We also successfully identified a method to test Dr. Bayly's theory of dynamic instability and believe that with an increase in flow rate our model could successfully achieve oscillation. Additionally, we also were able to remove the use of motors in the model, a significant goal of Dr. Bayly's, in order to create a responsive system rather than a smart system. Lastly, our project has tangible next steps that Dr. Bayly and his team can begin to work on. With more time and a larger budget this project should be able to be completed.

7.2.2 Working Prototype – Video Link

<https://www.youtube.com/watch?v=7jkjBoWDzi4>

7.2.3 Working Prototype – Additional Photos

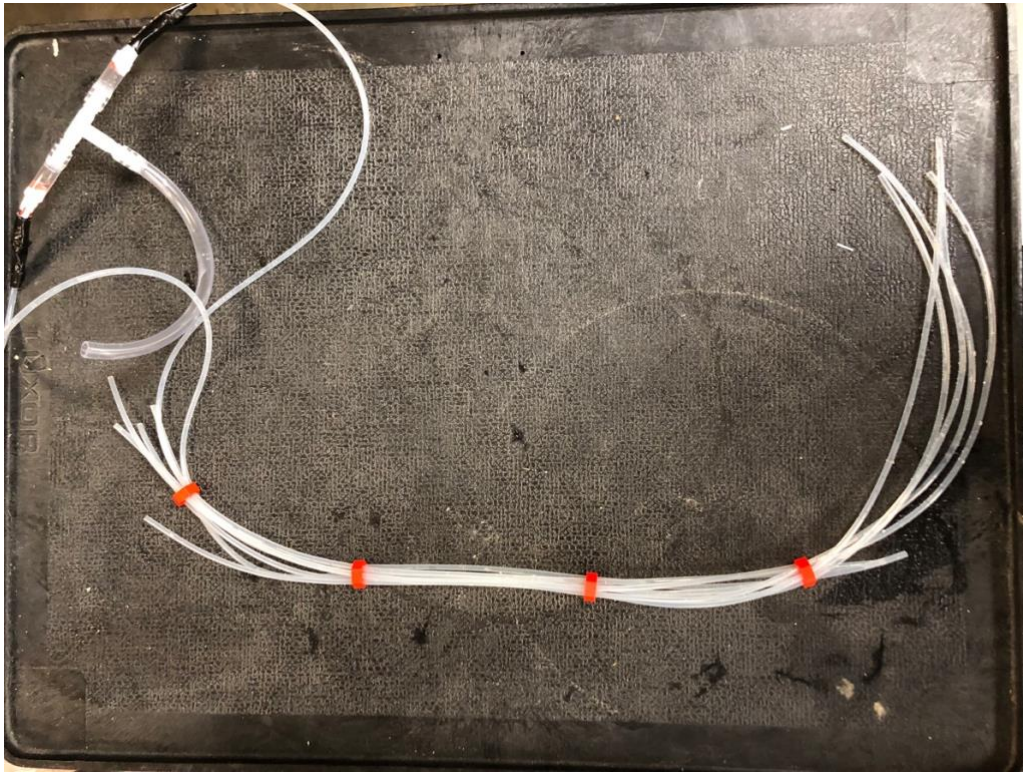

Figure 27: Close up view of cilium model

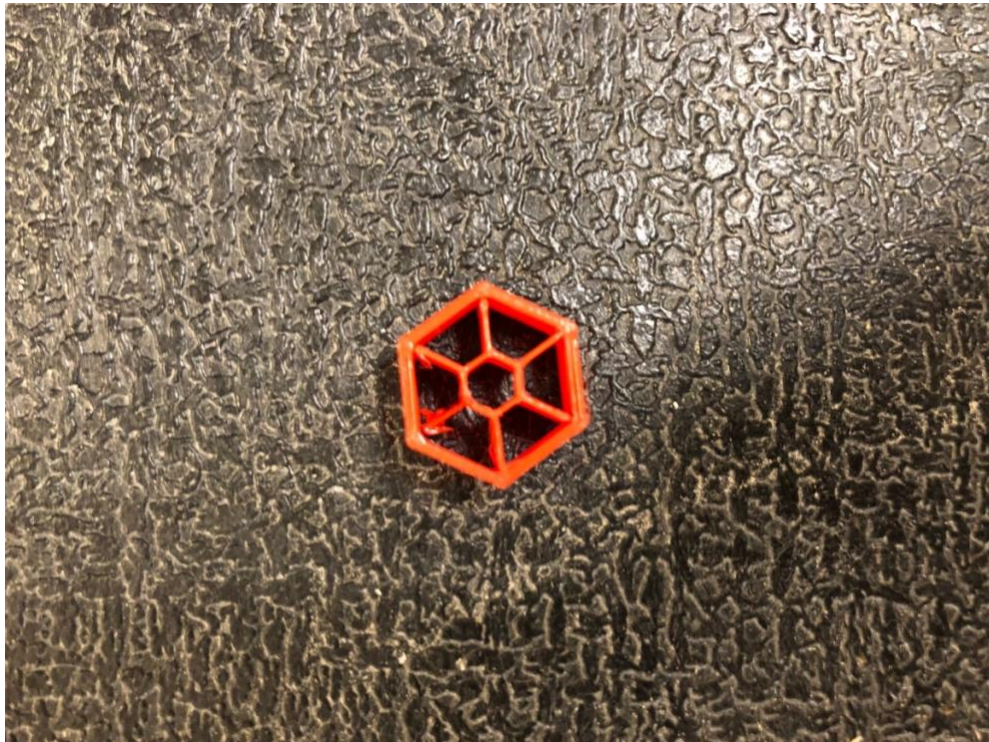

Figure 28: Close up view of 3D printed spacer

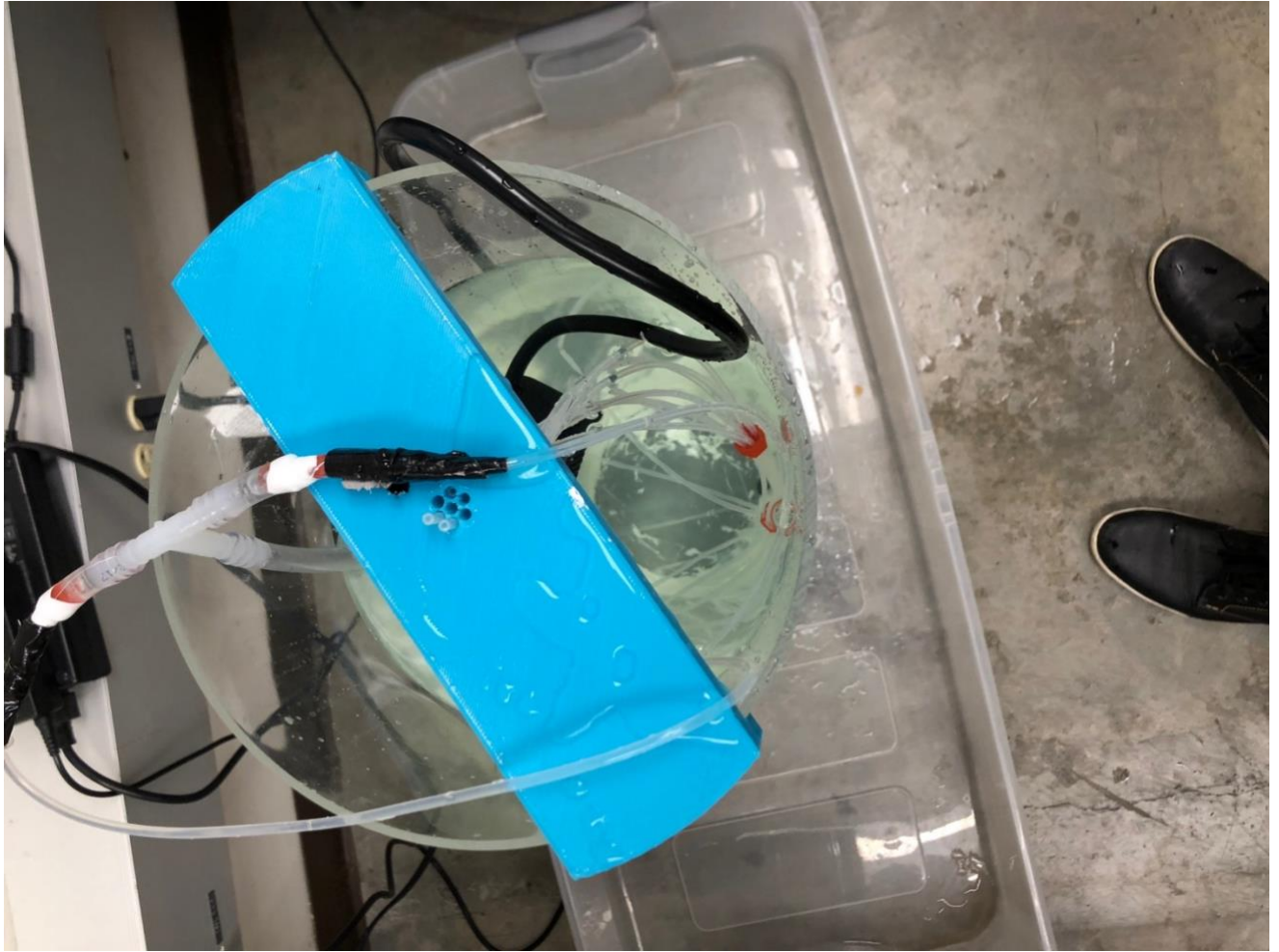

Figure 29: Top down view of prototype setup



Figure 30: Prototype setup



Figure 31: Close up view of acrylic tube attachment to base

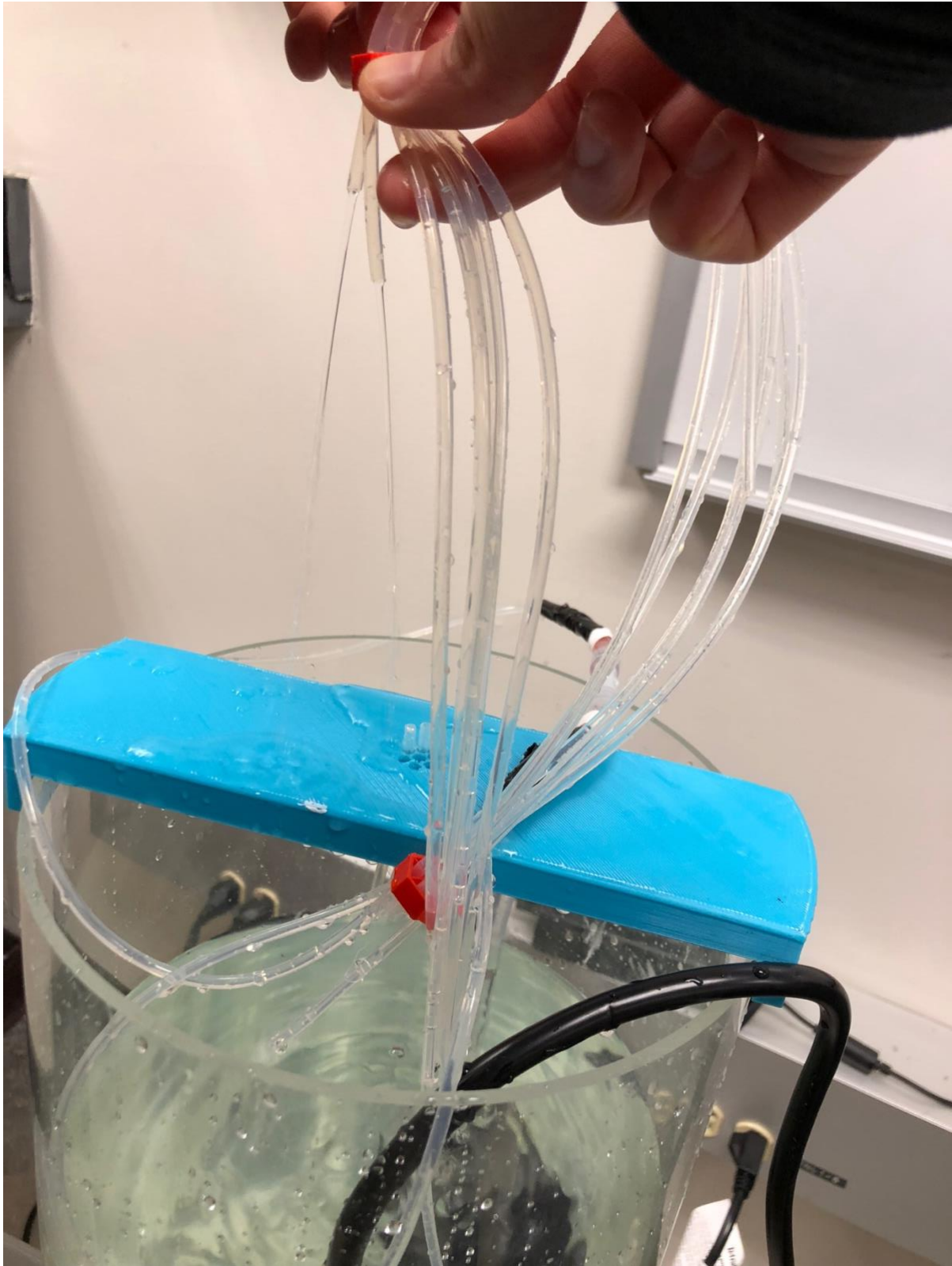

Figure 32: Close up view of working prototype with water running through tubes

8 DISCUSSION

8.1 DESIGN FOR MANUFACTURING – PART REDESIGN FOR INJECTION MOLDING

8.1.1 Draft Analysis Results

Before:

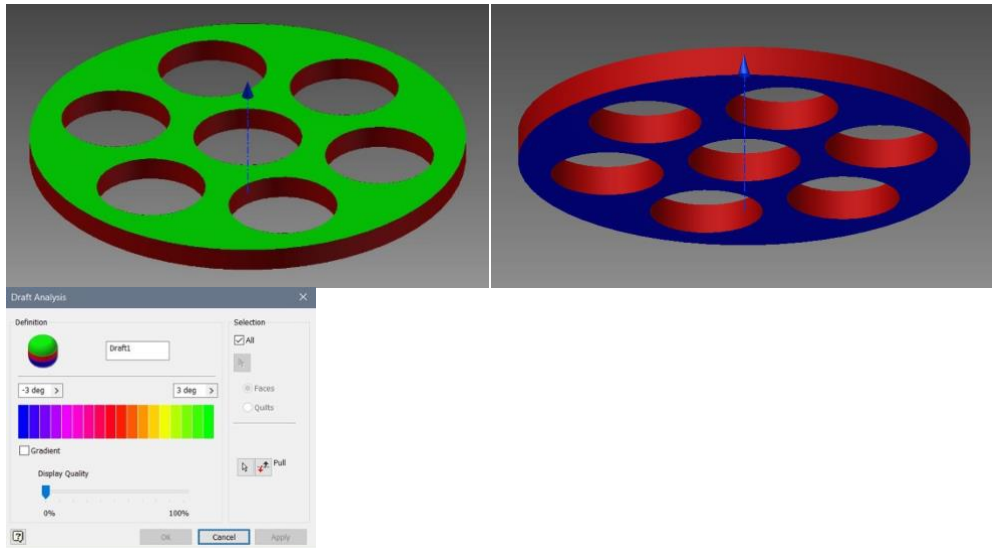

Figure 33: Spacer from above and below before draft was added. Key included for reference.

After:

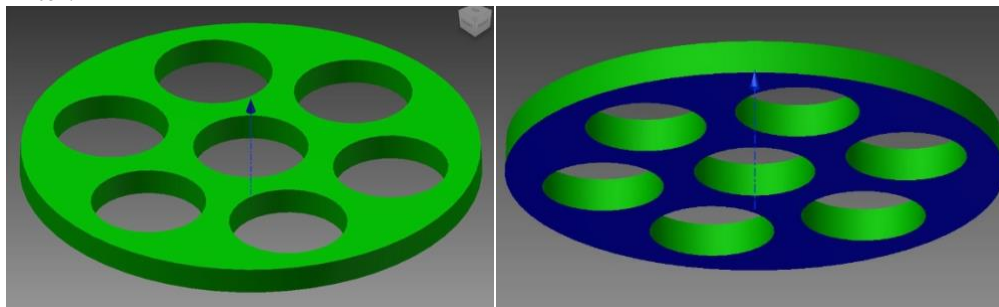

Figure 34: Spacer from above and below after draft was added

8.1.2 Explanation of Design Changes

The original design was modeled with a zero degree draft on all sides; the vertical edge around the circumference and inside each of the holes for the tubes was zero. After the draft analysis was completed, Fig. 5 shows that all of these vertical edges needed draft added to them. Once a three degree draft was added to each vertical edge, a new draft analysis was conducted. Figure 6 shows that each vertical edge had been corrected once draft was added.

8.2 DESIGN FOR USABILITY – EFFECT OF IMPAIRMENTS ON USABILITY

8.2.1 Vision

A person with vision impairment will still be able to operate our device. The person should still be able to turn on the device. If vision impairment is severe enough, they may not be able to see the oscillations taking place, but there is no way to make the oscillations more visible.

8.2.2 Hearing

Hearing impairments could restrict users from hearing issues with the pump such as burnout or malfunctions. Not hearing the pump would also force users to manually check if it was running. Additionally, users would not be able to hear water or air leaks in the system. To remedy this problem we could use dye in the water to make failures more easily visible.

8.2.3 Physical

Depending on the physical impairment, a person may have difficulty transporting and assembling our device. Our testing environment is about three feet tall and roughly one foot in diameter, and made of plastic. This is an unwieldy size and shape and could present a problem when moving it. In order to improve the ease of this, we could make a removable base that is not permanently attached to the pipe. Fine motor issues could also cause issues in using our model. Fitting the tubes in the spacers requires fine motor skills. In order to prevent this issues we could more effectively secure the spacers to the tubes to prevent them from slipping and requiring re-attachment.

8.2.4 Language

A language barrier should not present a problem in operating our device, since it is simply a pump that needs to be turned on. The difficulty could come in explaining the concept and function of the device to the user. To fix this, we could offer a pamphlet in multiple different languages explaining our device.

8.2 OVERALL EXPERIENCE

8.2.1 Does your final project result align with the initial project description?

Our final project does align with our initial project description. It is a macroscopic model of the cilia with the correct material and mechanical properties. Additionally, the environment we created mimics what cilia experience in the human body. Although our model does not create the oscillations observed in cilia, we did learn a lot about cilia's motion, find a possible method to replicate it by using opposing flows, create a significantly better testing environment than previous models, and detail several areas where Dr. Bayly and his lab can focus their efforts to further refine our prototype.

8.2.2 Was the project more or less difficult than you had expected?

This project was definitely more difficult than we expected. We frequently had developments in requirements as Dr. Bayly would make suggestions that often caused us to overhaul our design. Additionally, we had some significant struggles designing our environment. Our initial attempts failed and we were forced to continually re-design to ensure that it was able to hold the load of the water. Moreover, although we calculated the necessary flow rate to create dynamic instability and bought a pump that would theoretically put us far past that flow rate, our pump was not nearly strong enough to create the flow rate we needed. We all had a blast working on this project, but it was most definitely more difficult than we expected.

8.2.3 In what ways do you wish your final prototype would have performed better?

There are several ways in which the performance of our prototype could be improved. The most obvious improvement would be creating a sustained oscillation which is the only performance goal we did not meet. This could be achieved in two ways. First, a larger more robust pump could be set up to produce a higher flow rate in hopes of achieving dynamic instability. The pump we purchased following our calculations was unable to produce the flow rate we needed to potentially create dynamic instability and there is a chance that a larger pump could solve this problem. A second solution would be to use Resource™ ThickenUp Clear, a product that increases the viscosity of water. As the viscosity was a core

variable in the initial calculations we performed to determine length and material of the model, doing this would allow for the use of more ideal materials in the model such as nylon rods and perhaps a shorter length. In addition to achieving sustained oscillations in the model, highlighting these oscillations by distinguishing the model with the use of a colored dye would allow for more contrast between the model and the environment. Lastly, the environment could be improved in two ways. First, a more effective seal could be created by custom manufacturing the part or using a chemical bond to attach the acrylic. Additionally, a viewing window could be created in the environment to minimize distortion of the image and further improve the visibility of oscillations.

8.2.4 Was your group missing any critical information when you evaluated concepts?

I think the largest piece of information that we were missing was how to effectively seal two sheets of acrylic to hold the load of the column of water. Though we had some brief conversations, we didn't evaluate this issue thoroughly enough which led to some significant delays in our build process.

8.2.5 Were there additional engineering analyses that could have helped guide your design?

Building off the last question, performing an engineering analysis on the strength of the seal between the two pieces of acrylic would have been a great guide to designing our environment.

8.2.6 How did you identify your most relevant codes and standards and how they influence revision of the design?

We had a difficult time finding codes that were particularly relevant to our design. However, after meeting with Lauren Todd we found a few that were applicable especially surrounding water spillage and safety. Though we knew that our environment needed to be water tight, these codes reinforced that need and established it as one of our performance goals.

8.2.7 What ethical considerations (from the Engineering Ethics and Design for Environment seminar) are relevant to your device? How could these considerations be addressed?

Though our product does not have many ethical considerations the most prominent would be conservation of natural resources as it uses both water and electricity. In order to address these concerns a smaller system could be created. In doing so, less water and electricity would be used which would minimize waste over the lifespan of our prototype. Additionally, a further analysis of the chemicals used to bond the acrylic could be performed to limit the risk of environmental hazard.

8.2.8 On which part(s) of the design process should your group have spent more time? Which parts required less time?

The environment was one piece that we should have spent more time designing. We could have made a design that would be more watertight, and able to hold a larger load. That way, we wouldn't have to worry about the bottom popping off and spilling water everywhere. The model itself, once we were able to get the necessary engineering calculations done, was fairly simple to design. The spacers have gone through many iterations, but each design has been a relatively easy upgrade. Lastly, we also should have spent more time determining how large of a pump we needed. More engineering analysis would have been helpful to calculate the flow rate lost to friction and gravity.

8.2.9 Was there a task on your Gantt chart that was much harder than expected? Were there any that were much easier?

Determining the correct materials for our model was significantly more difficult than we expected it to be. It required extensive material research and countless hours of manipulating equations for dynamic scaling. The complicated nature of finding a material that was small enough but achieved the correct bending stiffness made designing the model far more difficult than we anticipated. With that said, the actual build process was significantly easier than we anticipated. It took a matter of days rather than weeks. Though none of us had ever worked with a 3D printer, the entire process went much more smoothly than we expected.

8.2.10 Was there a component of your prototype that was significantly easier or harder to make/assemble than you expected?

The environment was significantly harder to make than we expected. As we mentioned earlier, we really struggled with making it strong enough to hold the load of the water. In addition, we struggled to effectively print the spacers for our model. The spacers required far more customization than we initially anticipated as the 3D printer was not as accurate as we had expected it to be when printing small pieces.

8.2.11 If your budget were increased to 10x its original amount, would your approach have changed? If so, in what specific ways?

If our budget were increased 10 fold I think our approach would have definitely changed. Though our model would probably look the same, our manufacturing and creation of our prototype definitely would have. With that large of a budget we could have had everything custom manufactured, ensuring perfect seals between components and also increasing accuracy in our calculations by eliminating error. Lastly, with a larger budget we could have bought a much larger, more accurate, and variable pump which would have allowed us to test at many different flow rates to understand if dynamic instability is the cause of cilia's motion.

8.2.12 If you were able to take the course again with the same project and group, what would you have done differently the second time around?

If we were to perform this project again I think we would have begun meeting with Dr. Bayly earlier and for longer periods of time if possible. His insights were incredibly useful but receiving them only once a week when we were months into this project led to some significant delays. Working with him more closely would have allowed us to begin working on the final design much earlier.

8.2.13 Were your team member's skills complementary?

Our skills were definitely complementary! Some of us are great barnstormers, some of us have more experience in CAD than others, and some of us have more skills in performing engineering calculations. Even in working on the report and assignments, some of us are very skilled in Excel while others of us are great writers. Overall, we definitely think that our skills complemented each other well.

8.2.14 Was any needed skill missing from the group?

Skills in biology, working with acrylic, previous knowledge of 3D printing, and experience with dynamic scaling would have been incredibly beneficial for our group. These gaps in knowledge created some of the largest hurdles that we faced. Having someone on the team who knew how to work in these areas would have been of great benefit to us.

8.2.15 Has the project enhanced your design skills?

Our project definitely increased our design skills. Overall, I think we grew the most in realizing how important the initial design stage is to avoid unforeseen issues down the road. In the end, there will always be unpredicted hurdles. However, after completing this project as we look to attach future projects we will be sure to spend more time in the design phase of the project.

8.2.16 Would you now feel more comfortable accepting a design project assignment at a job?

Absolutely! We all feel more comfortable working on an end to end product and working in a team environment after working on the cilia this semester.

8.2.17 Are there projects you would attempt now that you would not have attempted before?

Nothing specific! After completing this project we are all much more comfortable with 3D printing and working with acrylic. Who knows, maybe we'll spend some time 3D printing things we need in the future!

9 APPENDIX A – PARTS LIST

	Part	Source Link	Supplier Part Number	Color, TPI, other part IDs	Unit price	Tax (\$0.00 if tax exemption applied)	Shipping	Quantity	Total price
1	Clear Cast Acrylic Tube	McMaster	8486K735	Clear	\$165.90	\$0.00	\$0.00	1	\$165.90
2	Clear Polycarbonate Epoxy Structural Adhesive	McMaster	8574K28	Clear	\$15.89	\$0.00	\$0.00	1	\$15.89
3	High Strength Epoxy Structural Adhesive	McMaster	7541A77	Water resistant	\$8.59	\$0.00	\$0.00	1	\$8.59
4	High Strength Epoxy Structural Adhesive	McMaster	7592A31	High Strength	\$9.25	\$0.00	\$0.00	1	\$9.25
5	High Temperature Silicone Rubber	McMaster	51135K71	Semi-Clear White	\$26.00	\$0.00	\$0.00	1	\$26.00
6	Active Aqua Submersible Water Pump	Amazon	AAPW40	40 gph	\$11.36	\$0.65	\$0.00	1	\$12.01
7	Tetra Fountain Pump	Menards	2689831	140 gph	\$19.92	\$1.91	\$0.00	1	\$21.83
8	1/4" Barb Tee Plastic	Menards	6806208	1/4" diameter	\$2.04	\$0.38	\$0.00	2	\$4.46
9	Micro Fuel Tube	Menards	6841310	7/64" ID x 1/4" OD 5'	\$4.49	\$0.43	\$0.00	1	\$4.92
10	Gorilla Construction Adhesive	HomeDepot	1001378150	9 oz, heavy duty	\$7.97	\$0.80	\$0.00	1	\$8.77
12	Smooth Rod Caulk Gun	HomeDepot	449032	10 oz, seal punch and spout cutter	\$2.77	\$0.29	\$0.00	1	\$3.06
13	Oatey Clear Primer for PVC	HomeDepot	592647	8 oz, for PVC and CPVC	\$7.99	\$0.81	\$0.00	1	\$8.80
14	Oatey Heavy Duty Clear PVC Cement	HomeDepot	212350	8 oz, heavy duty	\$8.39	\$0.85	\$0.00	1	\$9.24
16									\$0.00
Total:									\$298.72

Table 7: Parts List

10 APPENDIX B - CAD MODELS

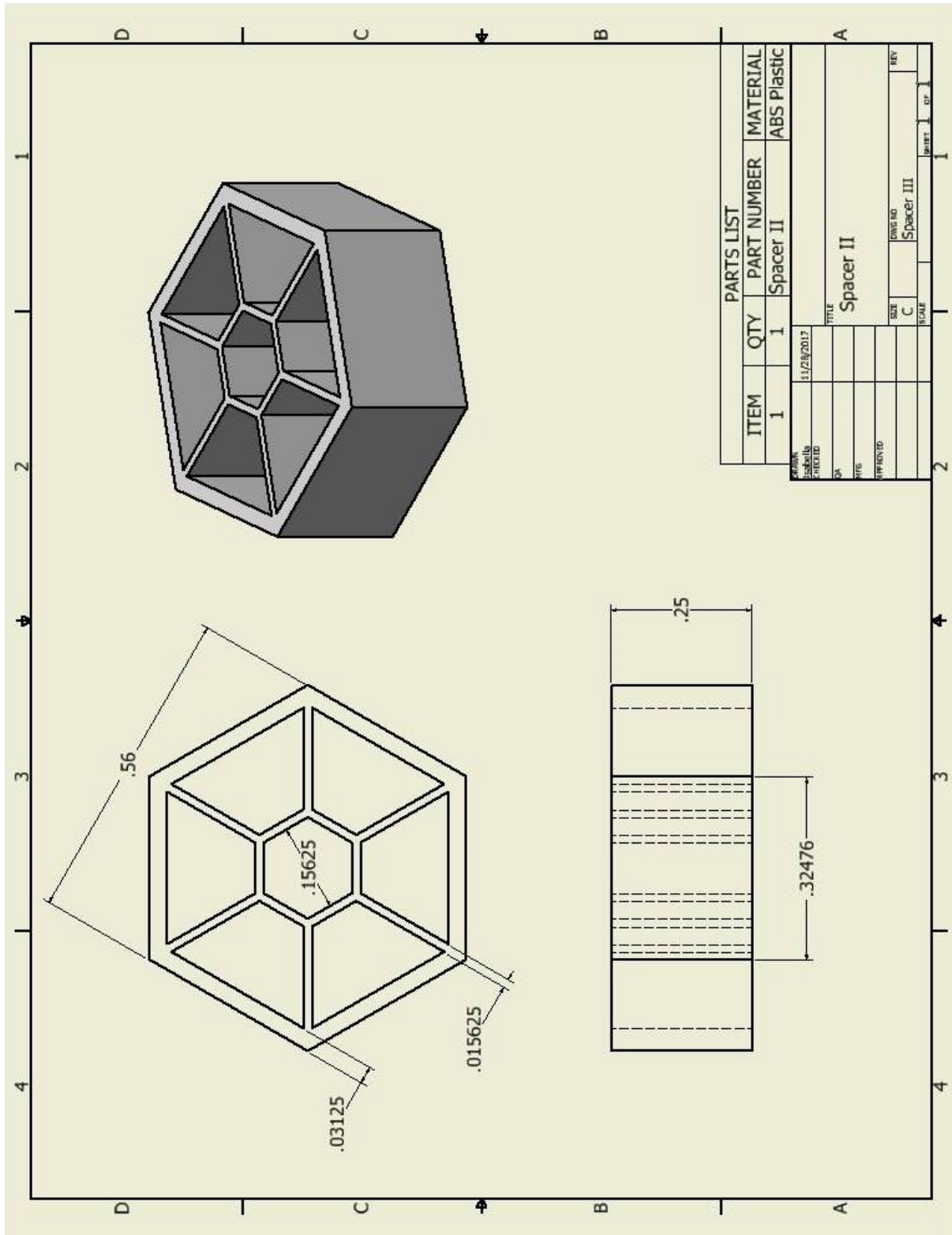

Figure 35: Spacer CAD

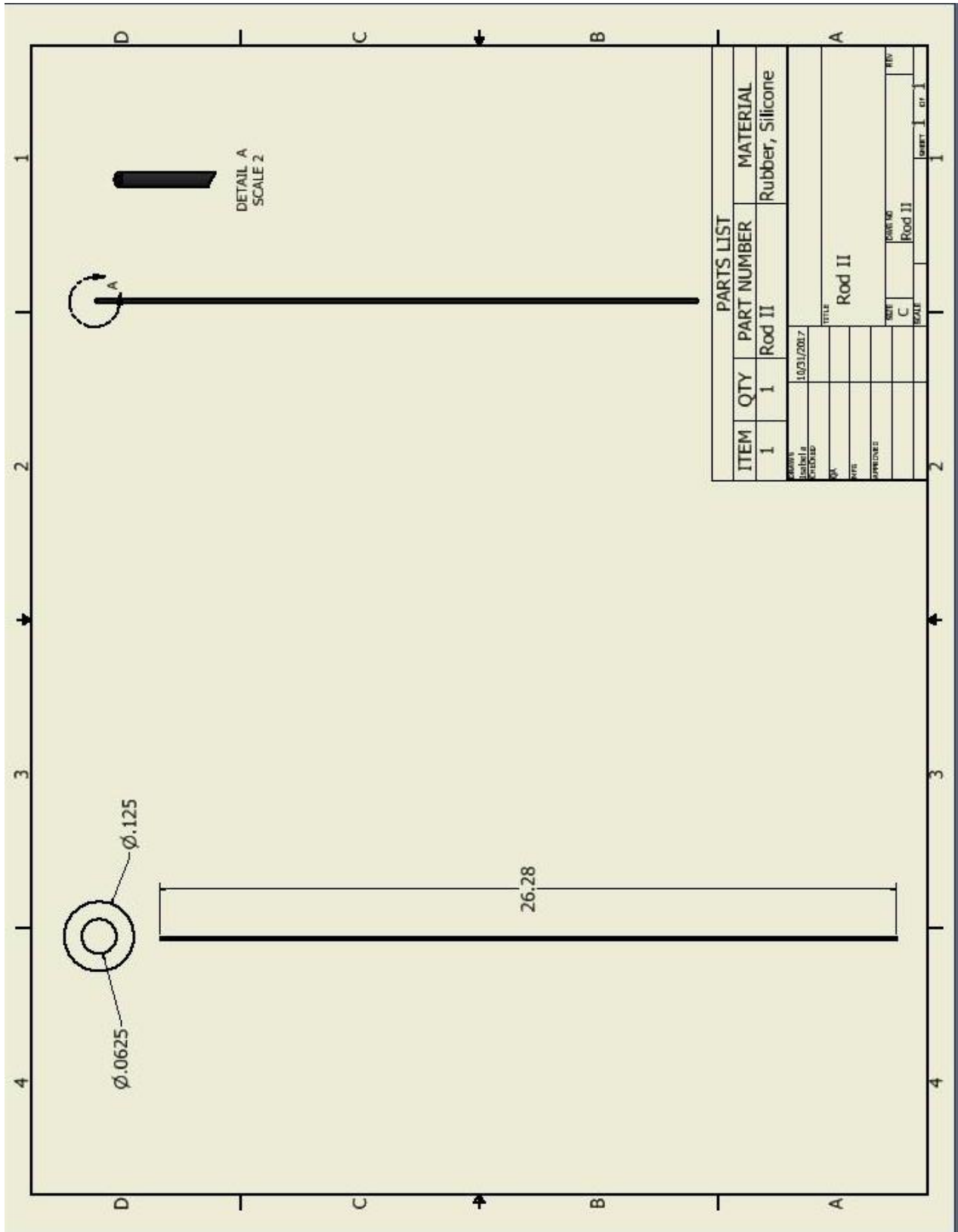

Figure 36: Rod CAD

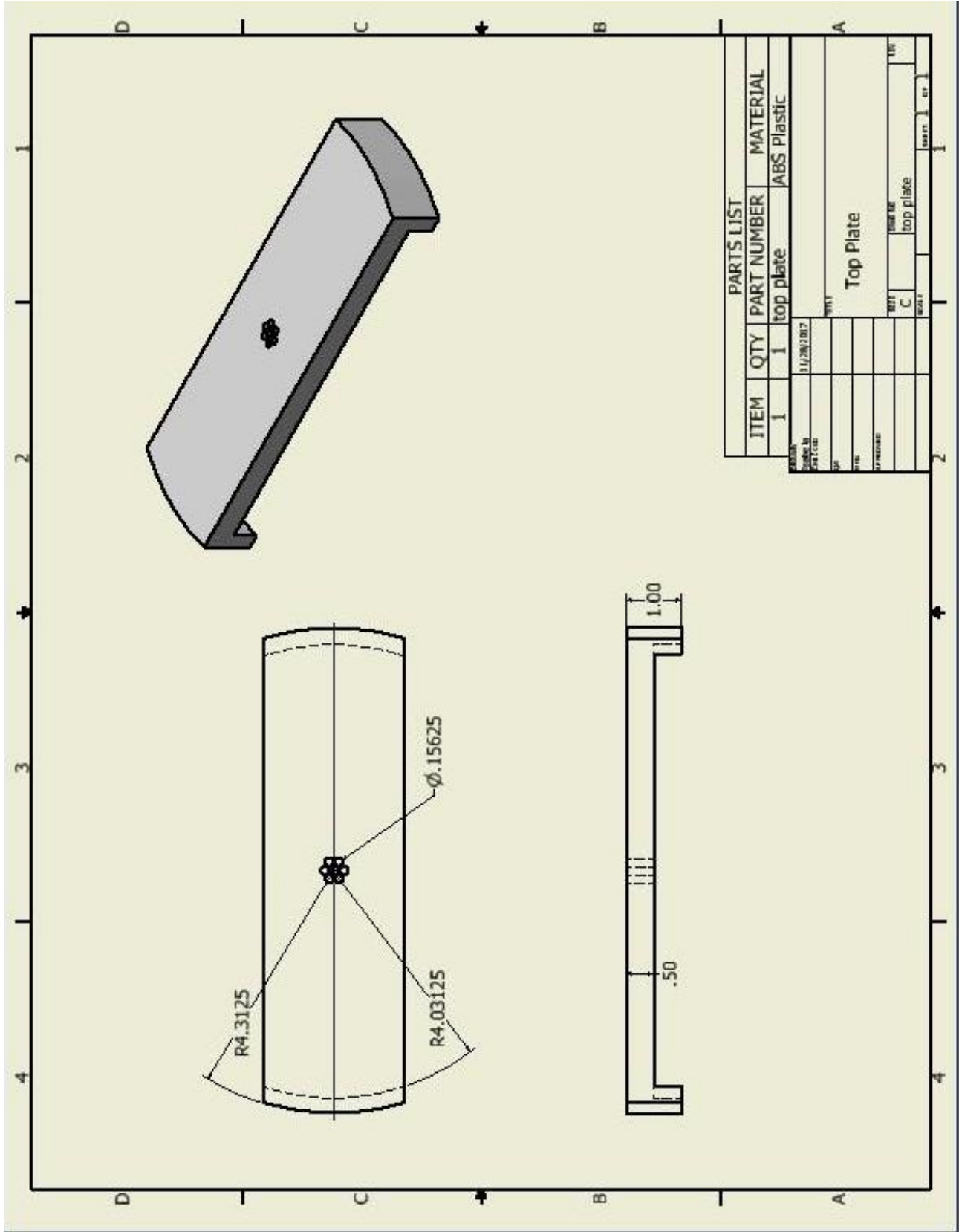

Figure 37: Top Plate CAD

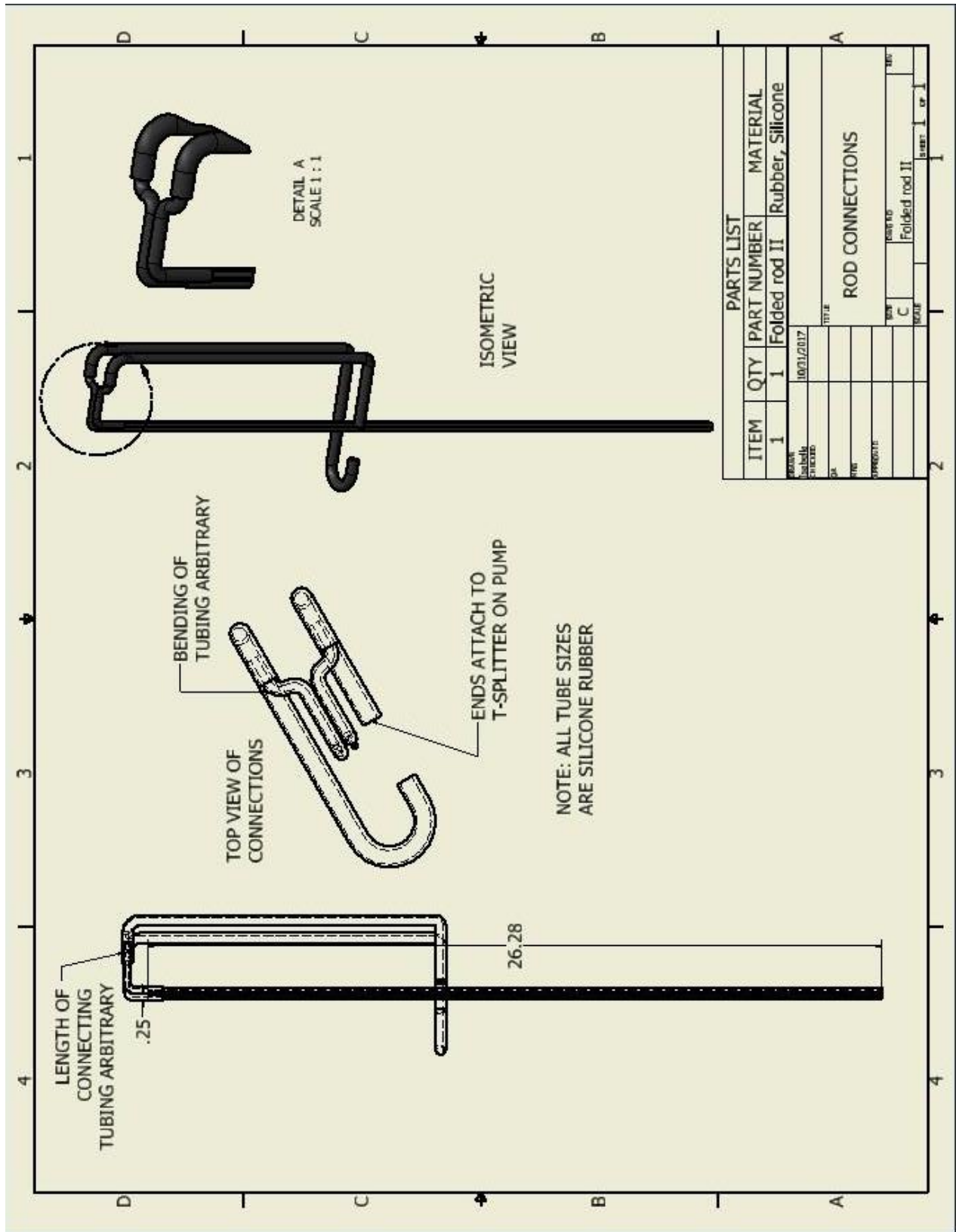

Figure 38: Rod Connections CAD

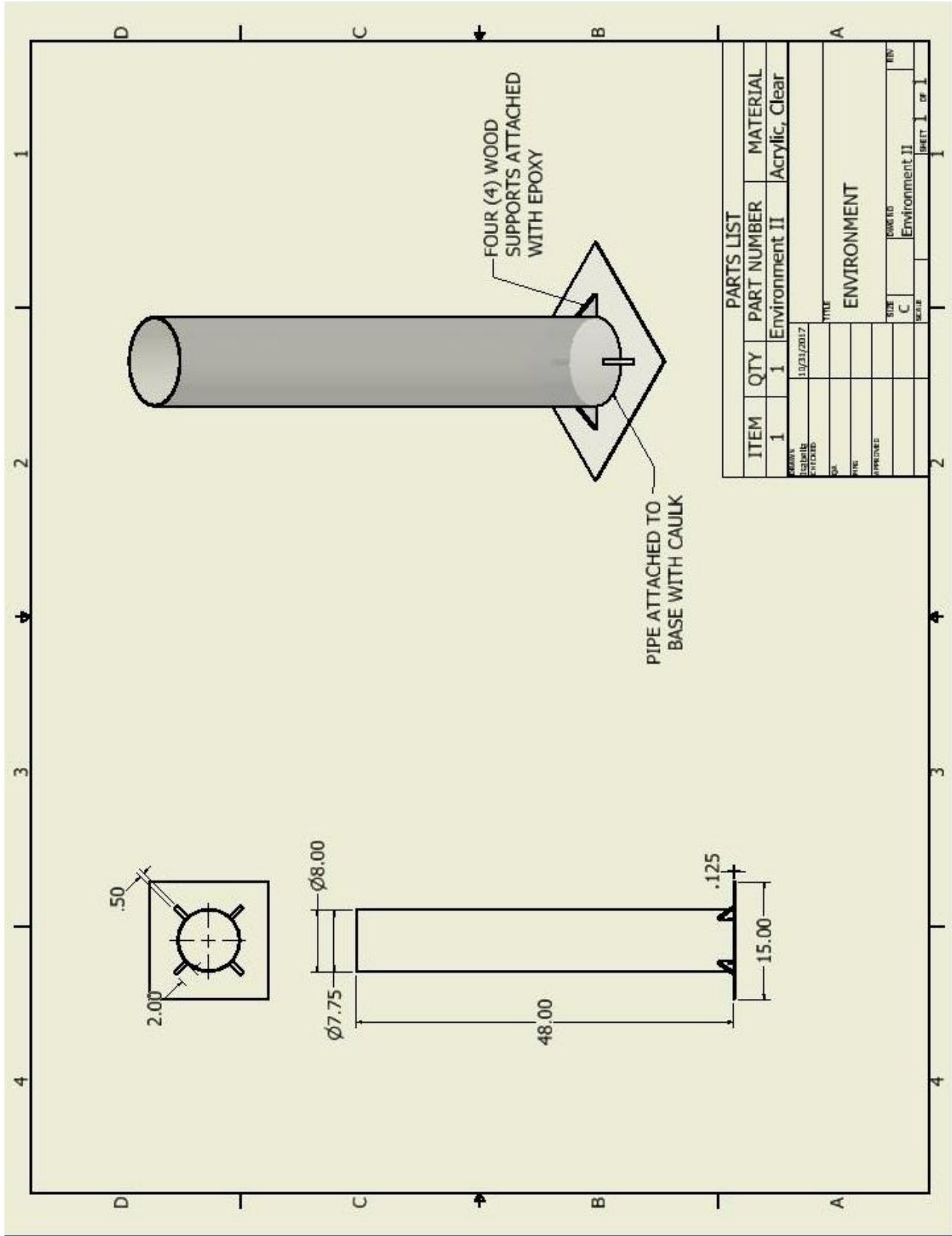

Figure 39: Environment CAD

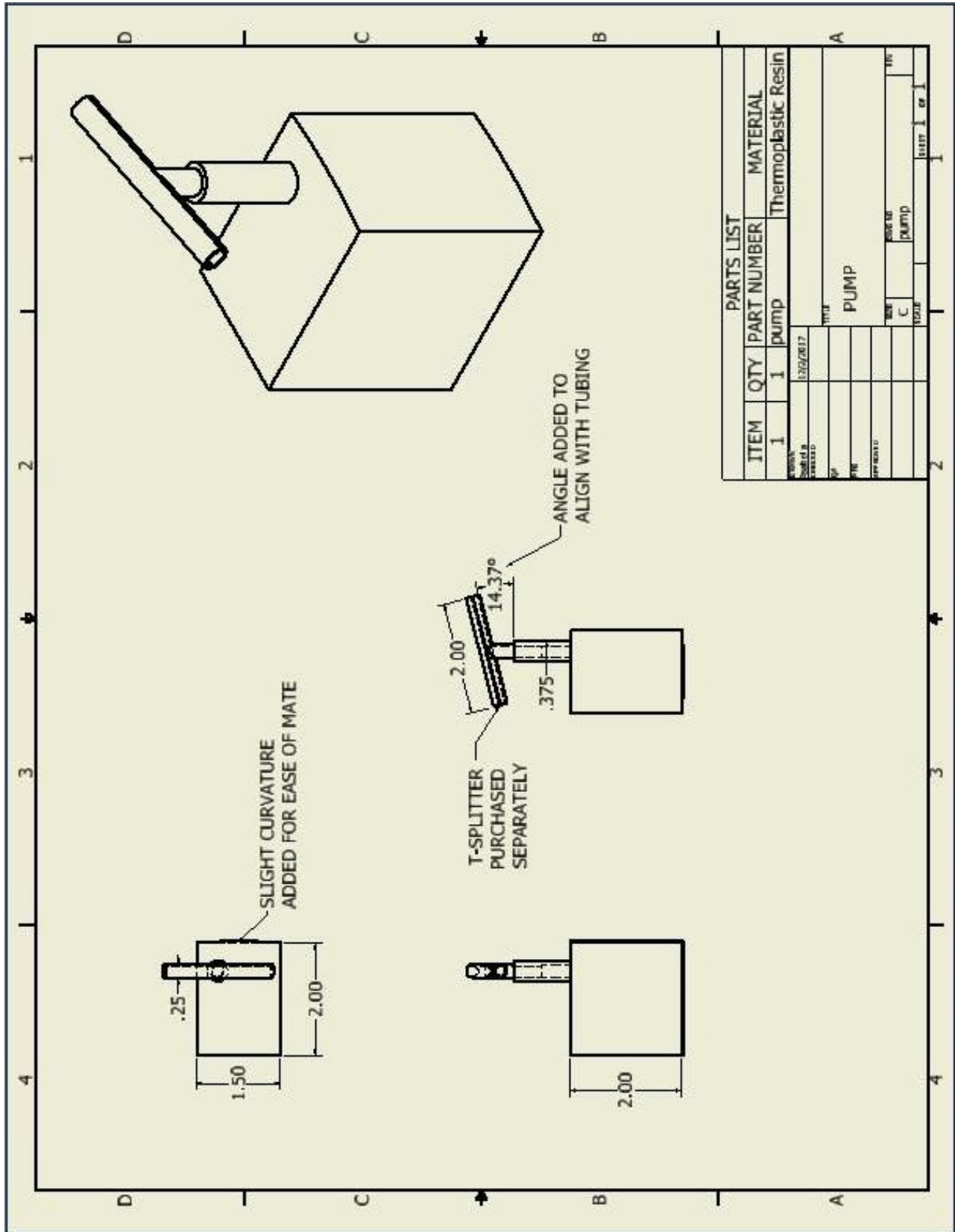

Figure 40: Pump CAD Model

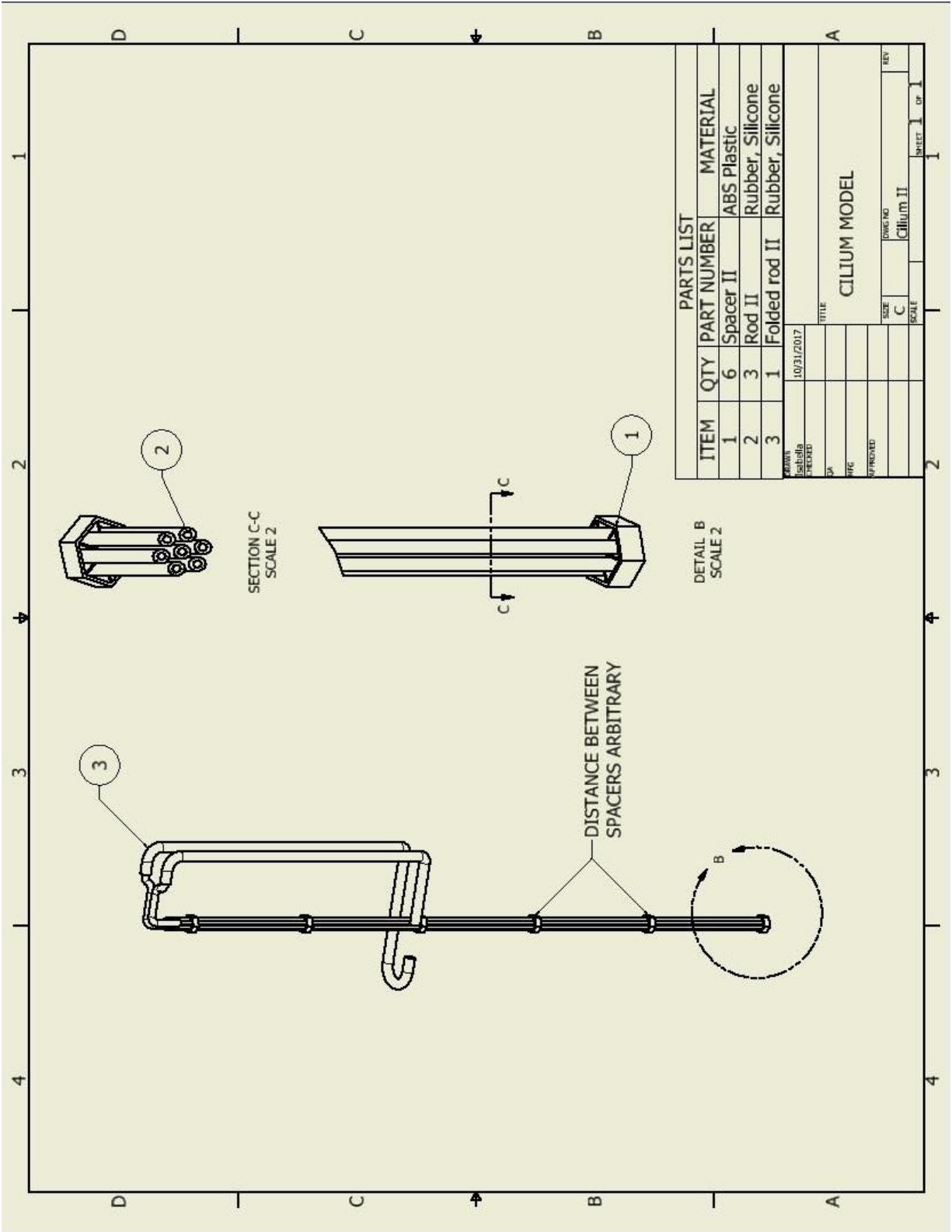

Figure 41: Cilium Model CAD

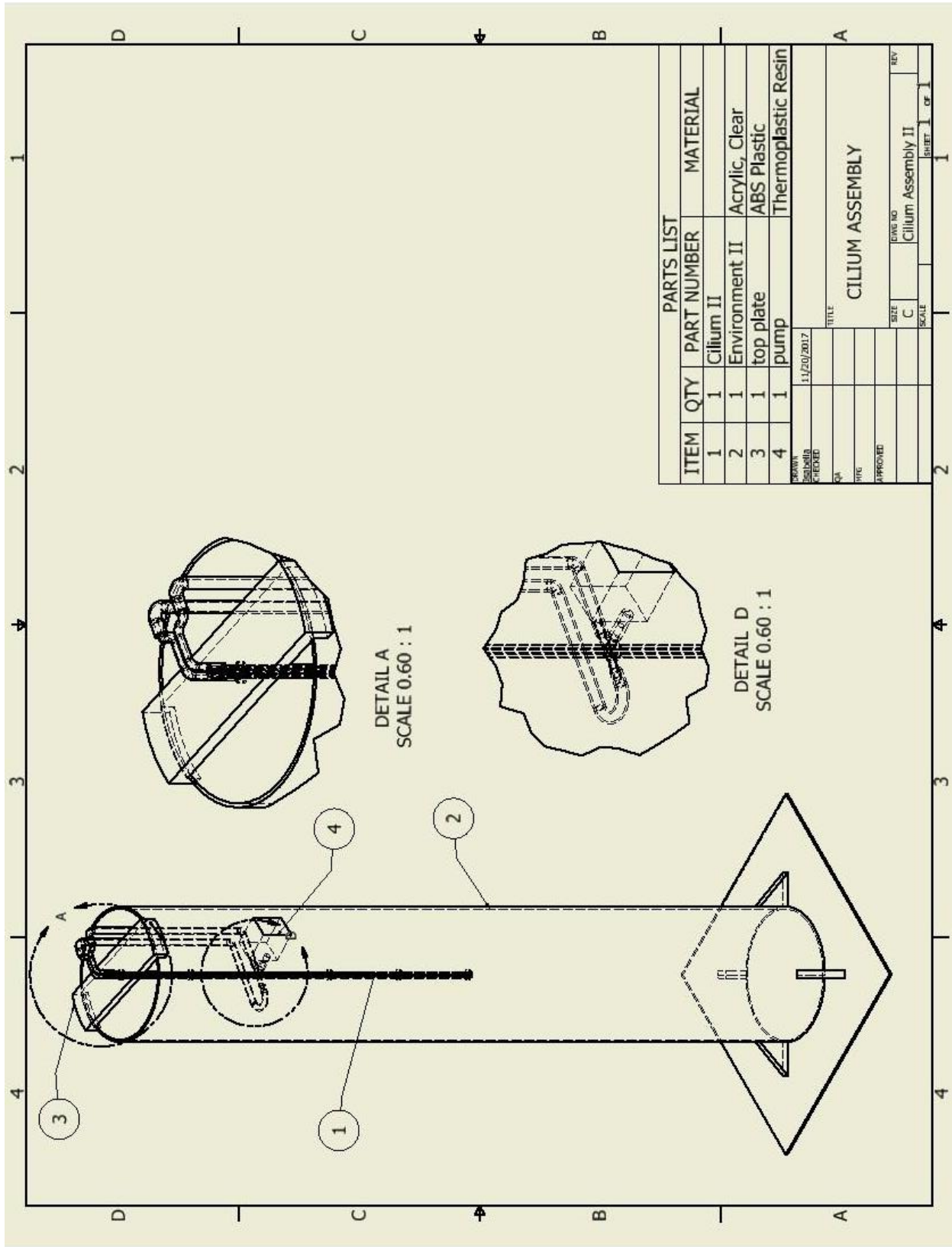

Figure 42: Cilium Assembly CAD Model

11 ANNOTATED BIBLIOGRAPHY

Arteaga, Alex, director. *Axobot 1.0 - Cilia Robot Prototype*. *Youtube*, 23 June 2014, www.youtube.com/watch?v=4KXzN3t_U10.

This video shows one of the previous prototypes from Dr. Bayly's lab. In this case, the model oscillates on a table by a student creating alternating torques on each side. It was useful to see how the model should oscillate, as well as one method of creating those oscillations.

Arteaga, Alex, director. *Dr. Bayly Lab at WUSTL: Cilia/Flagella Gearbox Model*. *Youtube*, 1 May 2016, www.youtube.com/watch?v=Rsr93B8GXjk.

This video shows another prototype from Dr. Bayly's lab. In this case, the model is again shown on a table and moves by using a drill to turn a threaded rod through threaded spacers which creates torque. This was used as another example of how to create oscillations and to see how the model should move.

Bayly, P. (2017). Macroscopic cilia notes [Handwritten notes]. Retrieved from Washington University in St. Louis.

The handwritten notes from Dr. Bayly were used to perform our engineering calculations, as well as used in our design. These notes were invaluable in our design process, and are the basis of our engineering analysis section.

Bray, Dennis. *Cell Movements: from Molecules to Motility*. Garland Pub., 2001. This book provided great information about the biology of the cilium appendage. We used it to help mimic the anatomical structure of the appendage in our model.

Link Assembly for a Snake like Robot Arm. 12 June 2003. First relevant patent.

This patent is for a robotic arm that moves with snake-like oscillations. It was one of the relevant patents that we found in our initial research, and gave us an example of how spaced out rings joined to hip joints can move in an oscillatory manner.

"Online Materials Information Resource - MatWeb." *Online Materials Information Resource - MatWeb*, www.matweb.com/. Website used for finding the material properties of materials used in this project, such as silicone rubber.

Robotic Snake. 2 July 1995. Second relevant patent.

This was another relevant patent that we found in our initial research. It is used in medical applications, so it helped show how small tubes can move in an oscillatory fashion. Considering that our model contains many small tubes that otherwise are used in medical applications, it was a useful resource to see an example of how that motion was created.