

Washington University in St. Louis

Washington University Open Scholarship

Mechanical Engineering Design Project Class

Mechanical Engineering & Materials Science

Fall 2016

Telescoping Cup Holder

Richard Kristian O. Pajarillo

Washington University in St. Louis

Eric Nehrbas

Washington University in St. Louis

Charlie Morrow

Washington University in St. Louis

Follow this and additional works at: <https://openscholarship.wustl.edu/mems411>



Part of the [Mechanical Engineering Commons](#)

Recommended Citation

Pajarillo, Richard Kristian O.; Nehrbas, Eric; and Morrow, Charlie, "Telescoping Cup Holder" (2016).

Mechanical Engineering Design Project Class. 54.

<https://openscholarship.wustl.edu/mems411/54>

This Final Report is brought to you for free and open access by the Mechanical Engineering & Materials Science at Washington University Open Scholarship. It has been accepted for inclusion in Mechanical Engineering Design Project Class by an authorized administrator of Washington University Open Scholarship. For more information, please contact digital@wumail.wustl.edu.



Washington University in St. Louis

SCHOOL OF ENGINEERING & APPLIED SCIENCE

MEMS 411 Design Report

Man Cave Masters –
Telescoping Cup
Holder

Charlie Morrow, Eric Nehrbas,
Richard Pajarillo

Our mission is to provide a cup holder for everyday use outside of vehicles. Our device will hold drinks of most sizes, and will keep them cool. Motion activation will raise the drink to a convenient height using a telescoping motion, and then lower to a sturdy position that is out of the way.

TABLE OF CONTENTS

List of Figures	6
List of Tables	7
1 Introduction.....	8
1.1 Project problem statement.....	8
1.2 List of team members.....	8
2 Background Information Study – Concept of Operations.....	8
2.1 A short design brief description that describes the problem	8
2.2 Summary of relevant background information	9
3 Concept Design and Specification – Design requirements	10
3.1 Operational requirements allocated and decomposed to design requirements.....	10
3.1.1 List of identified operational and design requirements	11
3.2 Four concept drawings	12
3.3 concept selection process	15
3.3.1 Preliminary analysis of each concept’s physical feasibility based on design requirements, function allocation, and functional decomposition	15
3.3.2 Concept scoring.....	17
3.3.3 Design requirements for selected concept.....	19
3.3.4 Final summary	19
3.4 Proposed performance measures for the design.....	20
3.5 Design constraints	20
3.5.1 Functional	20
3.5.2 Safety	20
3.5.3 Quality.....	20
3.5.4 Manufacturing.....	20
3.5.5 Timing.....	20
3.5.6 Economic	20
3.5.7 Ergonomic.....	20
3.5.8 Ecological	21
3.5.9 Aesthetic	21
3.5.10 Life cycle	21
3.5.11 Legal	21
4 Embodiment and fabrication plan	21

4.1	Embodiment drawing.....	21
4.2	Parts List	22
4.3	Draft detail drawings for each manufactured part.....	23
4.4	Description of the design rationale for the choice/size/shape of each part	26
4.5	Gantt chart.....	27
5	Engineering analysis	28
5.1	Engineering analysis results.....	28
5.1.1	Motivation.....	28
5.1.2	Summary statement of analysis done.....	28
5.1.3	Methodology	29
5.1.4	Results.....	29
5.1.5	Significance.....	30
5.1.6	Summary of code and standards and their influence.....	30
5.2	Risk Assessment	30
5.2.1	Risk Identification.....	30
5.2.2	Risk Impact or Consequence Assessment.....	31
5.2.3	Risk Prioritization	33
6	Working prototype	33
6.1	At least two digital photographs showing the prototype.....	33
	34
	34
6.2	A short videoclip that shows the final prototype performing.....	35
6.3	At least 4 additional digital photographs and their explanations	35
7	Design documentation.....	37
7.1	Final Drawings and Documentation	37
7.1.1	Engineering drawings	37
7.1.2	Sourcing instructions.....	Error! Bookmark not defined.
7.2	Final Presentation.....	37
7.2.1	A live presentation in front of the entire class and the instructors	Error! Bookmark not defined.
7.2.2	A link to a video clip.....	37
7.3	Teardown	38
8	Discussion.....	39

8.1	Using the final prototype produced to obtain values for metrics, evaluate the quantified needs equations for the design. How well were the needs met? Discuss the result.	39
8.2	Discuss any significant parts sourcing issues? Did it make sense to scrounge parts? Did any vendor have an unreasonably long part delivery time? What would be your recommendations for future projects?.....	40
8.3	Discuss the overall experience:.....	40
8.3.1	Was the project more or less difficult than you had expected?.....	40
8.3.2	Does your final project result align with the project description?	41
8.3.3	Did your team function well as a group?	41
8.3.4	Were your team member's skills complementary?.....	41
8.3.5	Did your team share the workload equally?.....	41
8.3.6	Was any needed skill missing from the group?	41
8.3.7	Did you have to consult with your customer during the process, or did you work to the original design brief?	41
8.3.8	Did the design brief (as provided by the customer) seem to change during the process?...	41
8.3.9	Has the project enhanced your design skills?	41
8.3.10	Would you now feel more comfortable accepting a design project assignment at a job?...	41
8.3.11	Are there projects that you would attempt now that you would not attempt before?	41
9	Appendix A - Parts List	42
10	Appendix B - Bill of Materials	Error! Bookmark not defined.
11	Appendix C - CAD Models	43
12	Annotated Bibliography	47

LIST OF FIGURES

Figure 1: Team Members.....	8
Figure 2: Closest Competitor	9
Figure 3: Second Closest Competitor	9
Figure 4: Device Operational and Design Requirements.....	11
Figure 5: Scissor Lift Design	12
Figure 6: Telescoping Design	13
Figure 7: Tri-Pod Design	14
Figure 8: Elevator Lift Design	15
Figure 9: Design Requirements for Telescoping Cup Holder.....	19
Figure 10: Final Assembly Drawing with Parts.....	21
Figure 11: Cup Holder Drawing	23
Figure 12: Cup Holder Insert Drawing	23
Figure 13: Small Shaft Drawing	24
Figure 14: Mid Shaft Drawing	24
Figure 15: Big Shaft Drawing.....	25
Figure 16: Bottom of the Base Drawing	25
Figure 17: Base Drawing	26
Figure 18: Stress Analysis	29
Figure 19: Risk Heat Map.....	33
Figure 20: Front Assembly View with Door Closed and Arm Retracted.	34
Figure 21: Front Assembly View with Door Open and Arm Extended.....	34
Figure 22: Inside of the Base	35
Figure 23: Location of Motion Sensor.....	36
Figure 24: Side View Showing Cord Hole	36
Figure 25: Insulated Holder	37

LIST OF TABLES

Table 1: Concept Scoring for Scissor Lift Design 17
Table 2: Concept Scoring for Telescoping Design 18
Table 3: Concept Scoring for Tri-Pod Design 18
Table 4: Concept Scoring for Elevator Design 18
Table 5: List of Parts Purchased 22

1 INTRODUCTION

1.1 PROJECT PROBLEM STATEMENT

Cup holders are a beloved feature of the modern automobile because they keep your drink stable and close, ensuring that minimal work is needed to grab it. Our mission is to provide a cup holder for everyday use outside of vehicles. Our device will hold drinks of most sizes, and will keep them cool. Motion activation will raise the drink to a convenient height using a telescoping motion, and then lower to a sturdy position that is out of the way. The finished product will minimize the amount of work required to retrieve the drink, and grab some attention as a unique fixture in any living room, tailgate, or man cave.

1.2 LIST OF TEAM MEMBERS

Figure 1: Team Members.

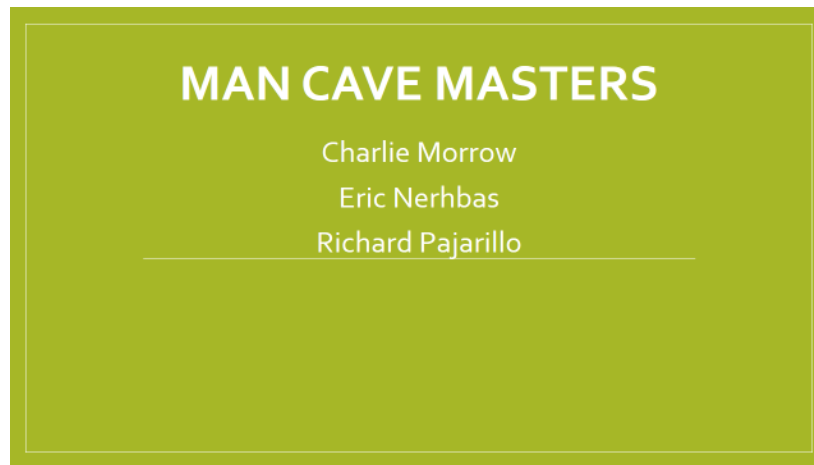

2 BACKGROUND INFORMATION STUDY – CONCEPT OF OPERATIONS

2.1 A SHORT DESIGN BRIEF DESCRIPTION THAT DESCRIBES THE PROBLEM

Sometimes one does not want to put forth any amount of effort in order to have a drink brought to them. Coffee tables and bedside tables are useful, but they can be space consuming and reaching for a drink that rests on a table can be a pain if you are simply having a lazy day watching a movie or watching your favorite sports team play. We are constructing an apparatus that holds a drink of choice, and can be lowered and raised by motion activation. The cup holder itself will be well insulated so the drink remains cold. The device will rest on the ground with your drink and once you wave your hand over the device, a telescoping motion will begin and your drink will be brought to you. The idea is to limit the amount of work it takes to grab your drink, while offering a creative alternative that can be used in any man cave.

2.2 SUMMARY OF RELEVANT BACKGROUND INFORMATION

Figure 2: Closest Competitor



Our device limits the amount of work you have to put into reaching for a drink and this piece of furniture achieves that purpose. One can place this object near wherever you plan to sit in order to keep your drink close by, but this device also has some disadvantages. First, it is not retractable which means that it takes up a lot of room wherever you plan to store it. Our device is appealing because it can lie flat on the floor out of sight until you get thirsty. Second, this device is not that portable so it is restricted to use inside. Our device can be brought to a picnic or to a friend's house. Lastly, it is not "cool enough". This device is a simple stand that you can bring closer to you. Our device has the appeal of being a conversation starter and it is more creative than this piece. Our device will also be equipped with an insulated cup holder so your drink remains cold. This device does not do that.

Figure 3: Second Closest Competitor



This device is probably our second best competitor. The unique aspect of this device is that it comes with a kit with multiple attachments. There is a wide base attachment if you want to keep it inside or if you are outside in a parking lot tailgating before your favorite sporting event. There is also a sharp attachment that can be driven into the ground if you are at a picnic.

There is also an area where you can keep your phone or other objects you do not want to hold on to. Although this device has the advantage of being able to change attachments based on where you are, our device is versatile enough that you do not need to put in extra work to build the device yourself. The whole point of our device is to limit the amount of work you have to do so this is an area where we beat this competitor. This device is also not retractable, so while it is standing it will take up a lot of room. Our device will also be equipped with an insulated cup holder so your drink remains cold. This device does not do that.

<https://www.google.com/patents/US20120181979>

This link provides a description of patents established for battery powered telescoping devices. Ultimately, this will be the riskiest part of our design. The ability to power the telescope and the ability to construct a working automated telescoping arm will be risky. Even though a motion sensor feature seems difficult, these devices are found throughout our society. The best example would be motion sensors in restrooms. Paper towel dispensers and motion automatic sink faucets have a short range, but motion sensors for flushing toilets have a longer range and we should be able to replicate that process easily. So with that being said, the riskiest part of our design is the telescoping feature and the fact that it has to be battery powered.

3 CONCEPT DESIGN AND SPECIFICATION – DESIGN REQUIREMENTS

3.1 OPERATIONAL REQUIREMENTS ALLOCATED AND DECOMPOSED TO DESIGN REQUIREMENTS

3.1.1 List of identified operational and design requirements

Figure 4: Device Operational and Design Requirements

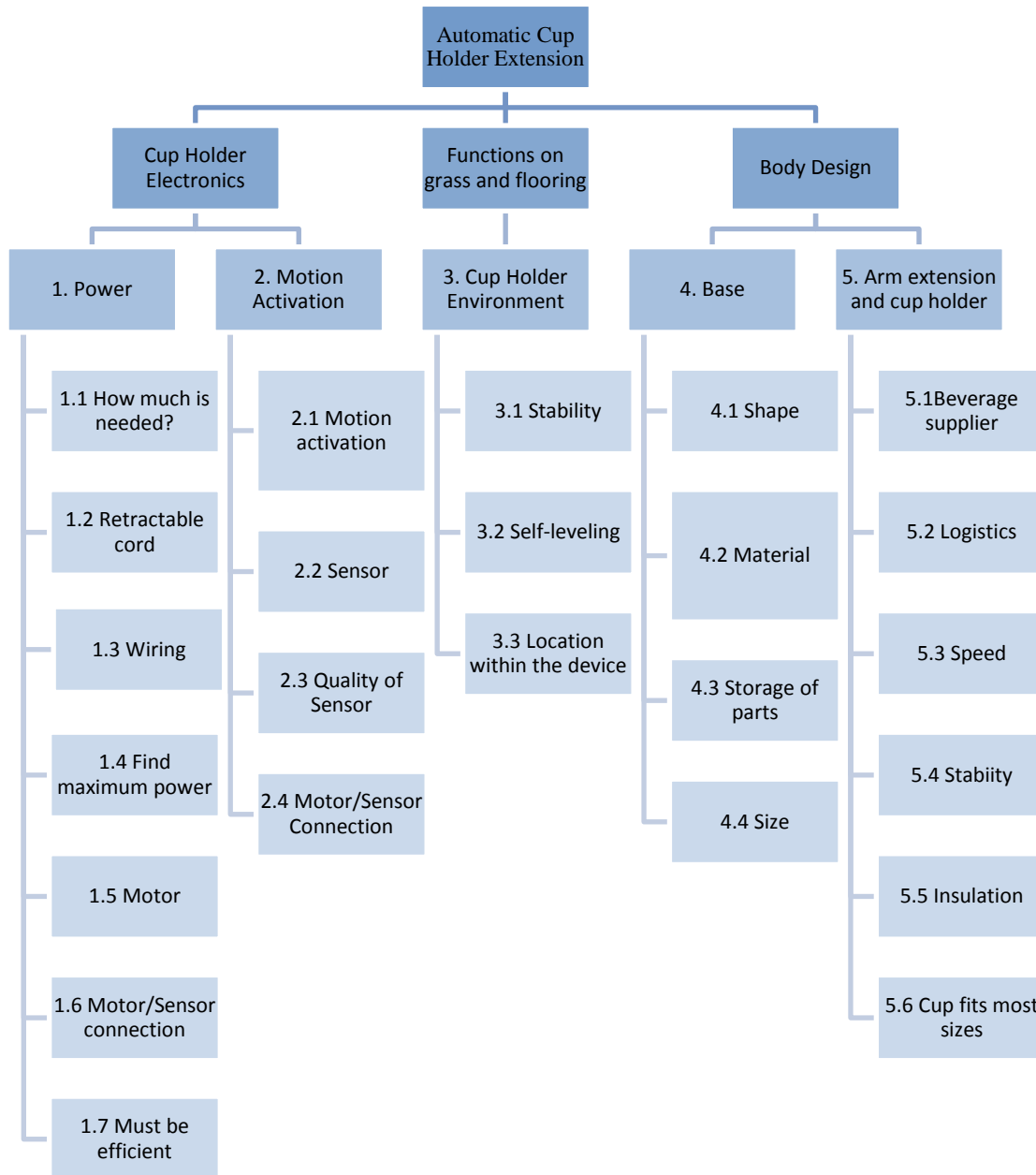

3.2 FOUR CONCEPT DRAWINGS

Figure 5: Scissor Lift Design

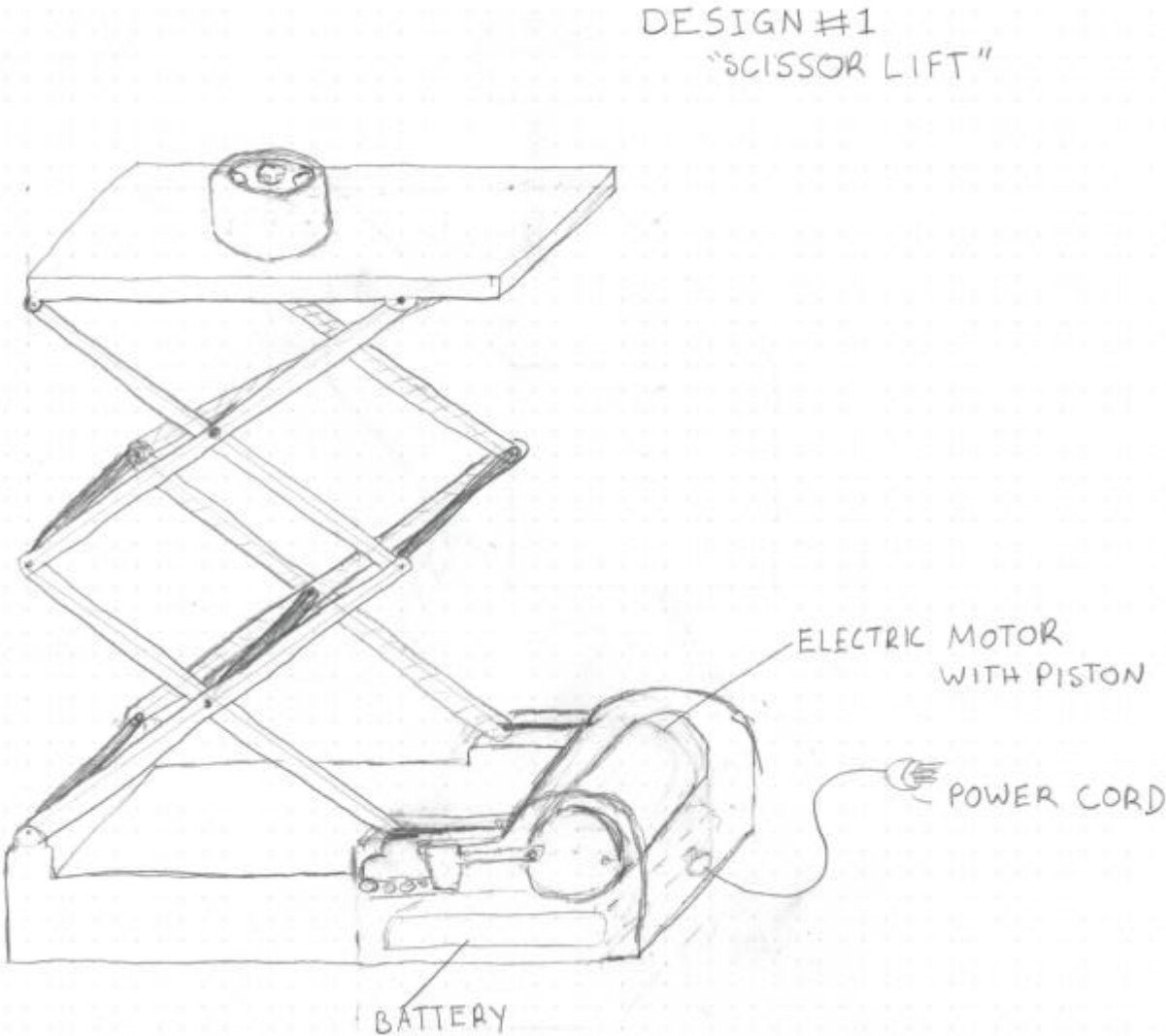

Figure 6: Telescoping Design

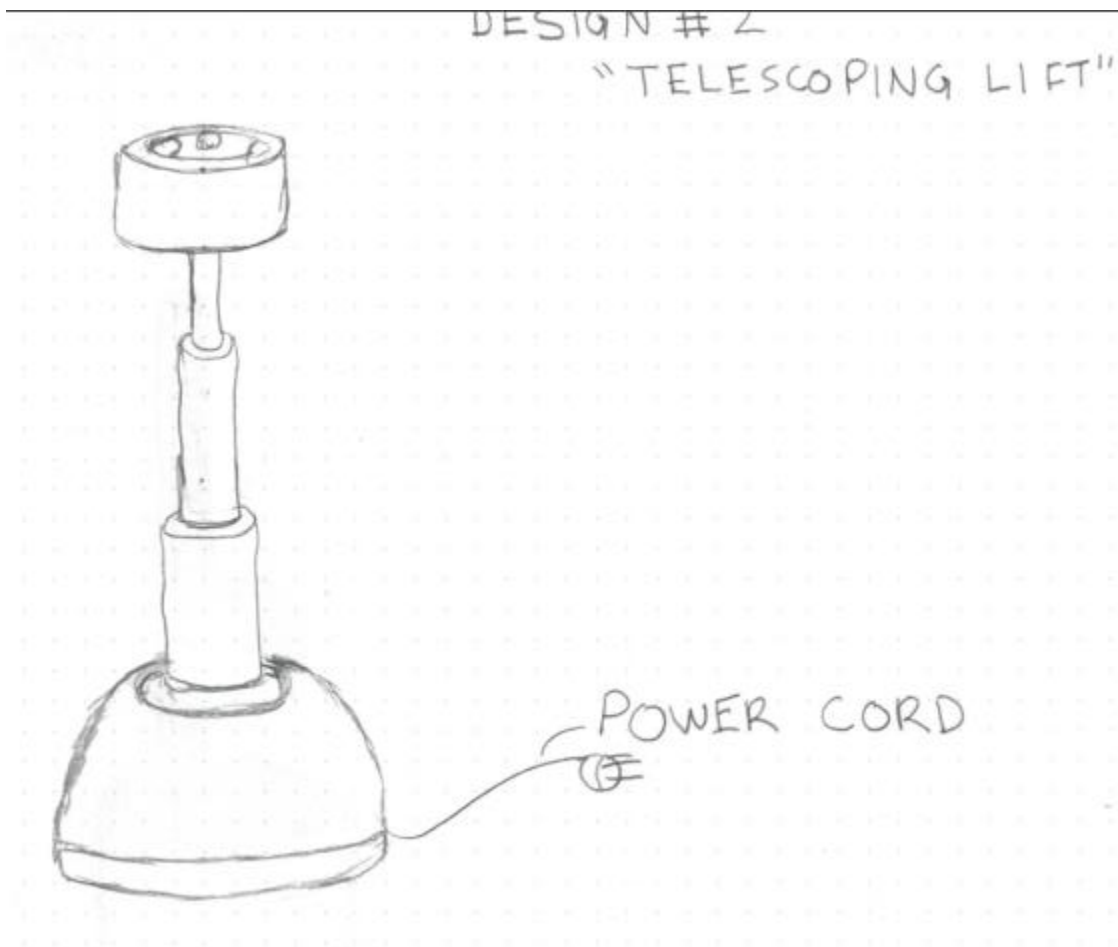

Figure 7: Tri-Pod Design

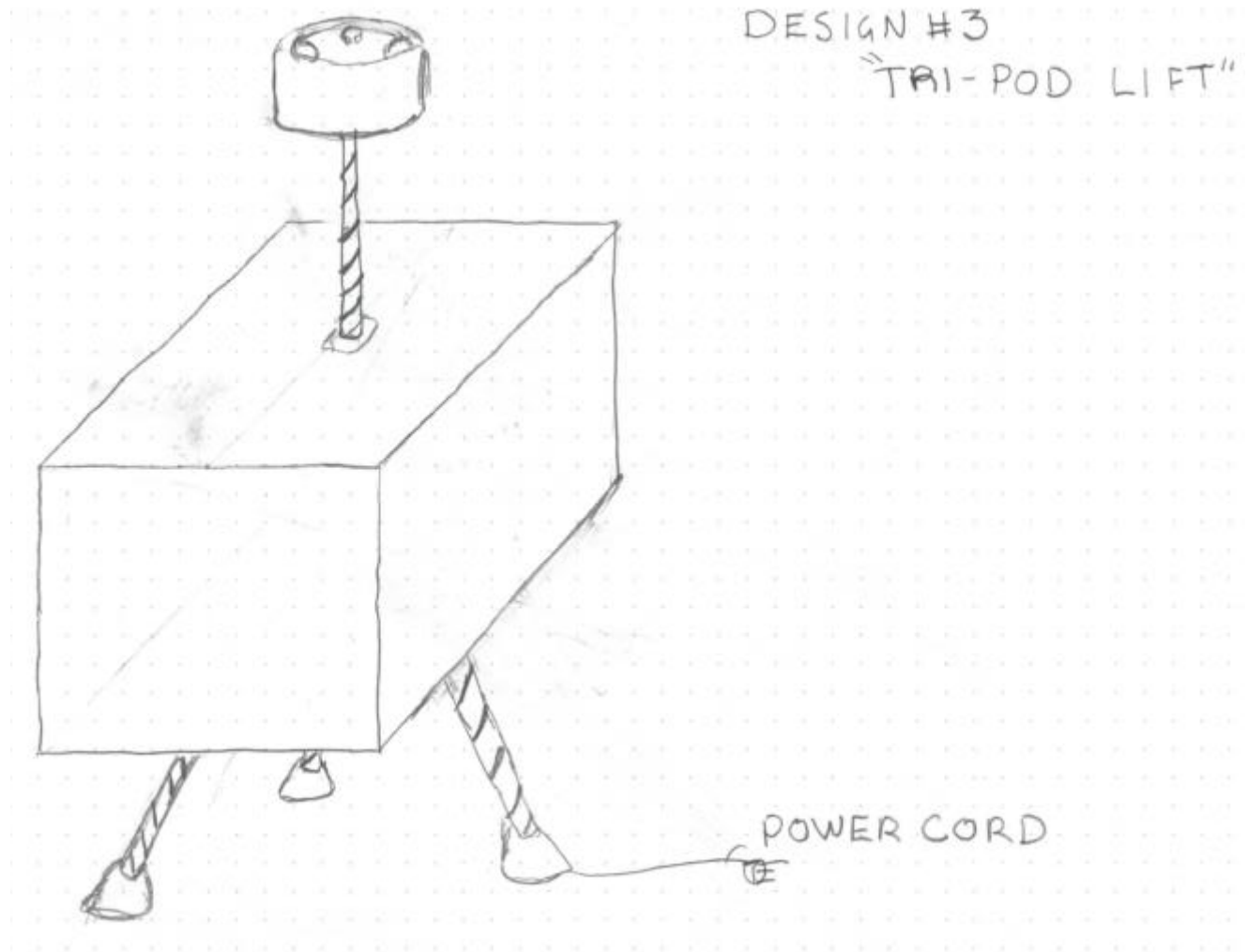
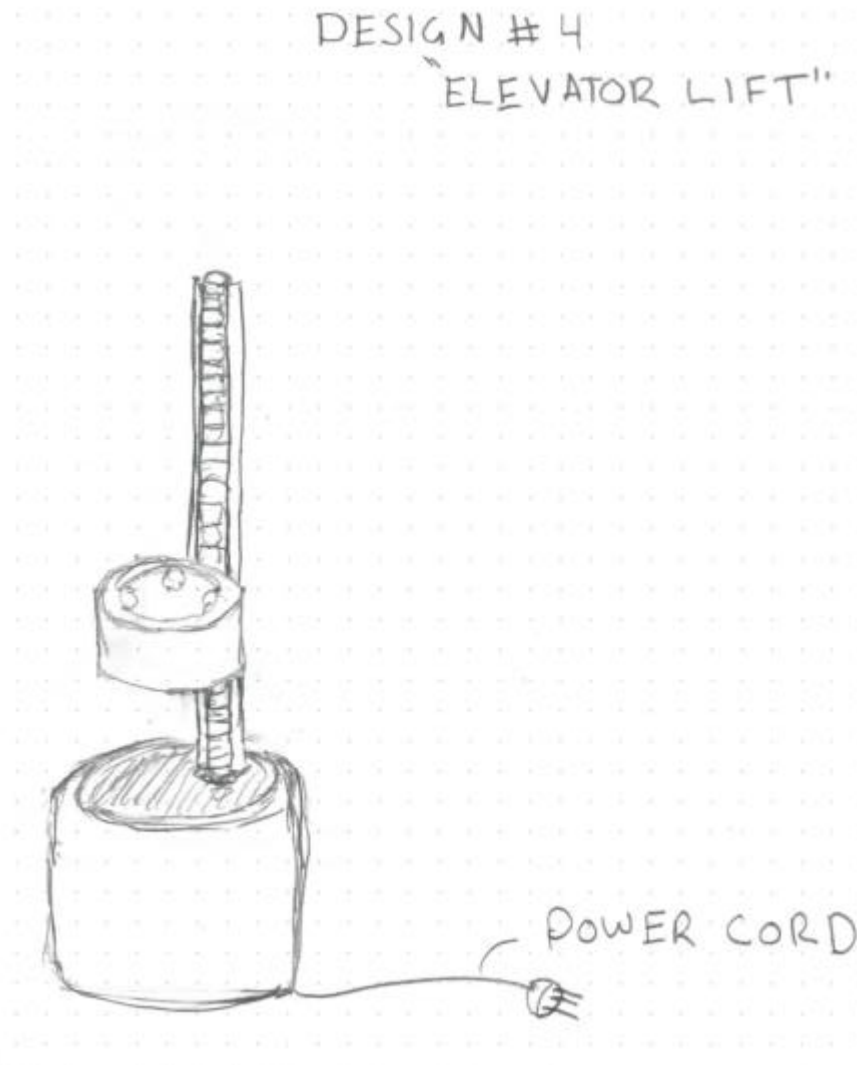

Figure 8: Elevator Lift Design



3.3 CONCEPT SELECTION PROCESS

3.3.1 Preliminary analysis of each concept's physical feasibility based on design requirements, function allocation, and functional decomposition

Scissor Lift Design Analysis

This design raises the insulated cup holder by means of a scissor lift. When retracted, the device will look like a rectangular box and once the motion activation feature senses a hand wave, the cup holder will rise two feet. This would give the entire device a height of thirty-eight and a half inches. The scissor lift feature will be powerful because it is a scaled down version of an industrial scissor lift. This design should also be sturdy because of the large base, and stabilizing beams between the two sets of X's. Some scissor lifts have only one level, but this

device will have two levels. This means that when extended, two X's will be created by the scissor lifting motion.

One issue regarding this design is that the interior features become exposed when the device is fully extended which does not look good. This is an issue because our device is a luxury that people do not need. Since it is a luxury, it is important to have the device be as appealing to the customer as possible and the scissor lift features creates an eye sore when extended. Another issue is that we need to follow the codes and standards for scissor lifts. People could be killed if they are caught in an industrial sized scissor lift. Obviously, our device will not be life-threatening but a small child or pet could get pinched by the scissor lift. Our customer happens to have small children and pets so the device needs to be safe.

Telescoping Design Analysis

This design is the most aesthetically pleasing and the most compact. The insulated cup holder is raised by tubes varying in diameter in a telescoping fashion. A total of three tubes are used and are able to fit inside one another to keep the device as compact as possible. The largest of the three tubes is raised first and once it reaches its maximum height, the second tube is raised and the process is repeated. Each tube would be eight inches tall and the cup holder would be two and half inches tall. This gives the device a maximum height of thirty-six inches when fully extended and twelve inches with the cup holder is fully retracted. The tubes would be lifted by a series of motors powering pistons, one piston for each tube.

The feasibility of this design is our biggest concern. Compared to the other three designs, this design is the most difficult to build, but it is the most aesthetically pleasing. Many telescoping arms use hydraulic cylinders, but this would add noise, and it would be very difficult to make the design portable. The compact design would keep the device out of sight when retracted and the telescoping feature would look better when extended compared to the other designs. For example, the scissor lift design will show the interior elements once it is fully extended. This is not visually appealing. Another issue with this device is that once extended, it will be the easiest of the four designs to knock down. The narrow tubes would not provide enough support especially with a heavier drink.

Tri-Pod Design Analysis

The tripod design can be low to the ground (when retracted) because it extends both from the top and bottom. This also allows for easy levelling because each of the three legs extends independently. An electronic level would allow the device to extend each of the legs to the optimal height before the drink arm is extended from the top. It would be feasible to feed the power cord through a leg so that the wire would not raise with the base (causing a snag) but it would require a lot of power in order to operate 4 motors, a motion sensor, a level, and possible audio cues. The notched rods that this design utilizes would alleviate some of the hand-pinching-potential that the scissor lift has, but steps would still be needed in order for safe operation.

The tripod design necessitates a base, containing motors, rod-ends, and a battery, that could rise off of the ground. Elevating the center of mass makes this design more tippable in comparison to the other three designs. It also depends on 4 motors, which makes the entire device much heavier than others, and also adds electrical complexity. Each additional motor also adds noise and cost to the design. With so many pieces, the base would need to be large, and would require more maintenance because there are many moving pieces. Because the design requires two extensions instead of one, additional time is required. It would thus be difficult to

complete an extension in 5 seconds. Also, a tripod with a giant box at the center isn't the sleekest design, which is an important consideration for such a niche product.

Elevator Design Analysis

This design is the most simplistic, and offers high feasibility and cost efficiency. One motor is required to turn the chain, which travels along the vertical track. The insulated cup-holder is attached to the chain such that at the bottom of its motion, it rests on the base, and at the top of the chain motion, the cup holder rests at the top of the track. The chain will need to have high tension and a strong connection with the cup holder to ensure that the weight from a heavier beverage wouldn't cause the chain to retract. For this reason, a strong track and chain would be required. With a motor of reasonable quality, the elevator design should easily be able to extend and retract within a 5 second window. The base itself could be sized in a variety of ways because it only needs to contain a battery, motor, and the end of a chain.

On the other hand, the track makes the machine highly inconvenient and obtrusive in a living room setting. Because the chain needs to attach to the motor and wrap around the track, the track wouldn't be removable for storage purposes. We considered an alternative design with a removable track, but it would necessitate hand feeding the chain through the track each time the device was used. For our target audience, we deemed this hassle unacceptable. Motion activation could be installed similarly to the other designs, but the track could get in the way of a hand wave. Although guards could be installed around the chain, great care would have to be taken to ensure a customer's hand would never contact the moving chain (which could cause injury). The biggest risk associated with this design has to do with the market for the product. If the cup holder obstructive makes noise, and has risk associated with its operation, would there be a reasonable amount of people who would prefer the novelty of this item over the functionality of a table?

3.3.2 Concept scoring

Table 1: Concept Scoring for Scissor Lift Design

Metric Number	Associated Needs	Metric	Units	Worst Value	Max Value	Actual Value	Normalized Value
1	1	Length	ft	1	2.5	2.5	1.000
2	2	Time	s	8	1	5	0.429
3	3	Battery and Cord Powered	Binary	0	1	1	1.000
4	4	Works on carpet or hardwood	Binary	0	1	1	1.000
5	5	Fits cup size	in	0	3.5	3.5	1.000
6	6	Safety and Stability	Level of concern	5	1	2	0.750
7	7	Extension/Retraction Noise	Expected noise level	5	1	2	0.750
8	8	Mutable Cheer	Binary	0	1	1	1.000
9	9	Sleek	Aesthetic Score	0	5	3	0.600
						TOTAL	7.529

Table 2: Concept Scoring for Telescoping Design

Metric Number	Associated Needs	Metric	Units	Worst Value	Max Value	Actual Value	Normalized Value
1	1	Length	ft	1	2.5	2.5	1.000
2	2	Time	s	8	1	6	0.286
3	3	Battery and Cord Powered	Binary	0	1	1	1.000
4	4	Works on carpet or hardwood	Binary	0	1	1	1.000
5	5	Fits cup size	in	0	3.5	3.5	1.000
6	6	Safety and Stability	Level of concern	5	1	3	0.500
7	7	Extension/Retraction Noise	Expected noise level	5	1	2	0.750
8	8	Mutable Cheer	Binary	0	1	1	1.000
9	9	Sleek	Aesthetic Score	0	5	5	1.000
TOTAL							7.536

Table 3: Concept Scoring for Tri-Pod Design

Metric Number	Associated Needs	Metric	Units	Worst Value	Max Value	Actual Value	Normalized Value
1	1	Length	ft	1	2.5	2.5	1.000
2	2	Time	s	8	1	8	0.000
3	3	Battery and Cord Powered	Binary	0	1	1	1.000
4	4	Works on carpet or hardwood	Binary	0	1	1	1.000
5	5	Fits cup size	in	0	3.5	3.5	1.000
6	6	Safety and Stability	Level of concern	5	1	3	0.500
7	7	Extension/Retraction Noise	Expected noise level	5	1	5	0.000
8	8	Mutable Cheer	Binary	0	1	1	1.000
9	9	Sleek	Aesthetic Score	0	5	1	0.200
TOTAL							5.700

Table 4: Concept Scoring for Elevator Design

Metric Number	Associated Needs	Metric	Units	Worst Value	Max Value	Actual Value	Normalized Value
1	1	Length	ft	1	2.5	2.5	1.000
2	2	Time	s	8	1	3	0.714
3	3	Battery and Cord Powered	Binary	0	1	1	1.000
4	4	Works on carpet or hardwood	Binary	0	1	1	1.000
5	5	Fits cup size	in	0	3.5	3.5	1.000
6	6	Safety and Stability	Level of concern	5	1	5	0.000
7	7	Extension/Retraction Noise	Expected noise level	5	1	5	0.000
8	8	Mutable Cheer	Binary	0	1	1	1.000
9	9	Sleek	Aesthetic Score	0	5	0	0.000
TOTAL							5.714

3.3.3 Design requirements for selected concept

Figure 9: Design Requirements for Telescoping Cup Holder

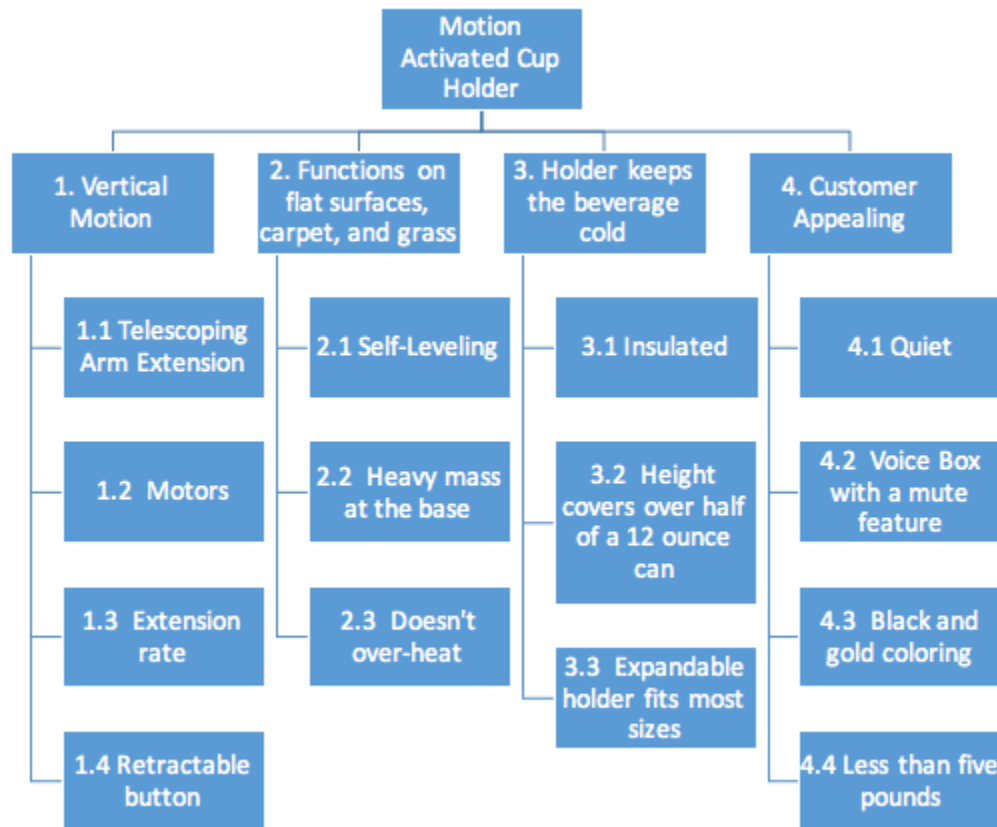

3.3.4 Final summary

The winning concept is the telescoping lift. The hydraulic telescoping cylinders design is the most aesthetically pleasing and the most compact, but it is also the most difficult to design. While it is difficult to design, the benefits outweigh the costs. Ultimately, we want our product to be as aesthetically pleasing as possible so we valued that attribute higher than the other. The scissor lift was a close second but because of its appearance we did not choose it.

Although the tripod design would be the easiest to level, this design contains too many parts. A base, multiple motors, rod-ends and a battery are few of the parts that are in this design. The electrical complexity is unwanted, and the weight of the product will be heavier due to the amount of motors and parts needed to operate the product. The elevation of the center of mass makes this design less sturdy and this could be a problem for customers with small children or pets.

The elevator design is the most simplistic and offers high feasibility and cost efficiency. Because one motor is utilized to run the device, the elevator design can easily extend and retract in five seconds or less. A strong track and chain is necessary for this design, but the track is obstructive, makes too much noise and has risk associated with its operation. Although a removable track could be an alternative, hand feeding the chain would be a hassle for the customer.

3.4 PROPOSED PERFORMANCE MEASURES FOR THE DESIGN

3.5 DESIGN CONSTRAINTS

3.5.1 Functional

- Telescoping vertical motion
- Load of 22 ounces
- Arduino control system
- Motion sensor

3.5.2 Safety

- No pinching between the shaft and cup holder
- Non-tippable
- Usable by any adult

3.5.3 Quality

- Codes and regulations
- Extensively tested

3.5.4 Manufacturing

- 3-D printers
- Bolted and glued

3.5.5 Timing

- Production delivery date of November 18

3.5.6 Economic

- Cost of \$173
- Limited size market; only for man cave owners
- Wood and PLA

3.5.7 Ergonomic

- Fully installed

- 2.5 feet when fully extended

3.5.8 Ecological

- Natural resources (wood)

3.5.9 Aesthetic

- Customizable

3.5.10 Life cycle

- Recyclable materials
- Life-cycle of about 10 years

3.5.11 Legal

- FDA approved

4 EMBODIMENT AND FABRICATION PLAN

4.1 EMBODIMENT DRAWING

Figure 10: Final Assembly Drawing with Parts

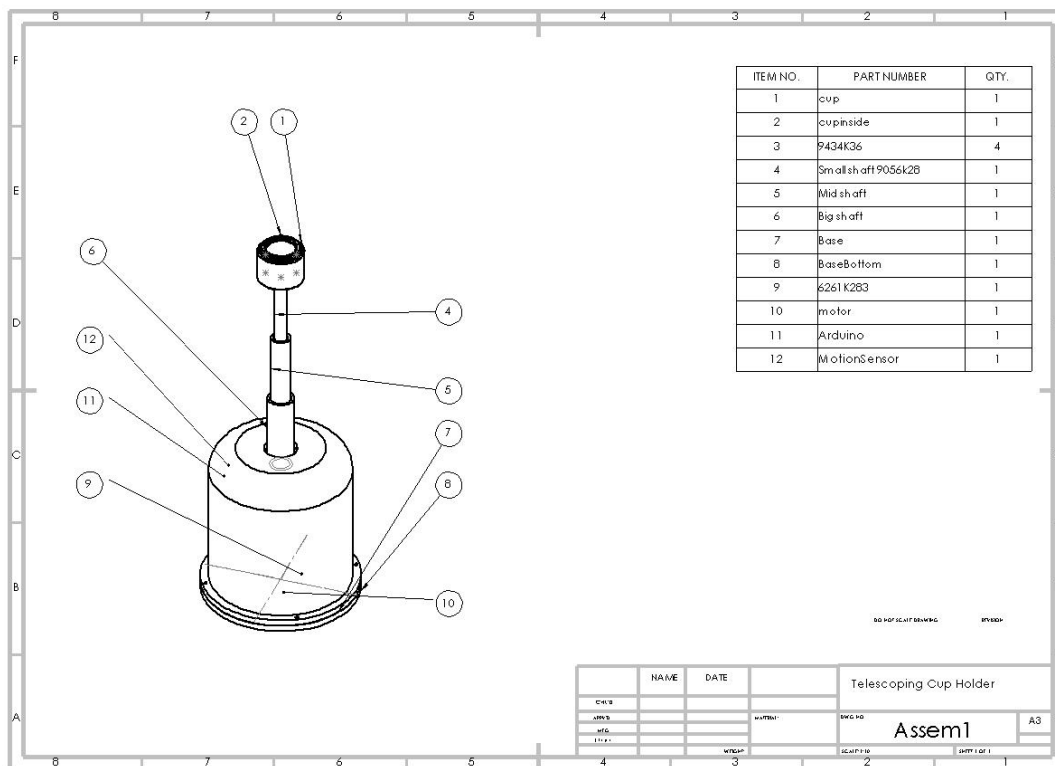

4.2 PARTS LIST

Table 5: List of Parts Purchased

	<i>Part</i>	<i>Source Link</i>	<i>Supplier Part Number</i>	<i>Color, TPI, other part IDs</i>	<i>Unit price</i>	<i>Tax</i>	<i>Shipping</i>	<i>Quantity</i>	<i>Total price</i>
1	Motion Sensor	Adafruit	ESHCSR501	Arduino Attachment	\$9.95	\$0.00	\$8.59	1	\$18.54
2	Arduino	Adafruit	1050-1024-ND	Uno	\$24.95	\$0.00	\$8.59	1	\$33.54
3	Motor	The Robot Market Place	G1611267	Black	\$16.00	\$0.00	\$13.50	1	\$29.50
4	Motor Driver	The Robot Market Place	9056k76	6" Length	\$49.99	\$0.00	\$0.00	1	\$49.99
5	Ropes	Home Depot - N/A	541-098 386-523	2 Ropes	\$1.55	\$0.15	\$0.00	1	\$1.70
6	Electronics	Gateway Electronics - N/A	12263055	Power source, wires, connector	\$16.95	\$1.29	\$0.00	1	\$18.24
7	Connectors	The Robot Market Place	9056k81	6" Length	\$2.99	\$0.00	\$0.00	1	\$2.99
Total:									\$154.50

4.3 DRAFT DETAIL DRAWINGS FOR EACH MANUFACTURED PART

Figure 11: Cup Holder Drawing

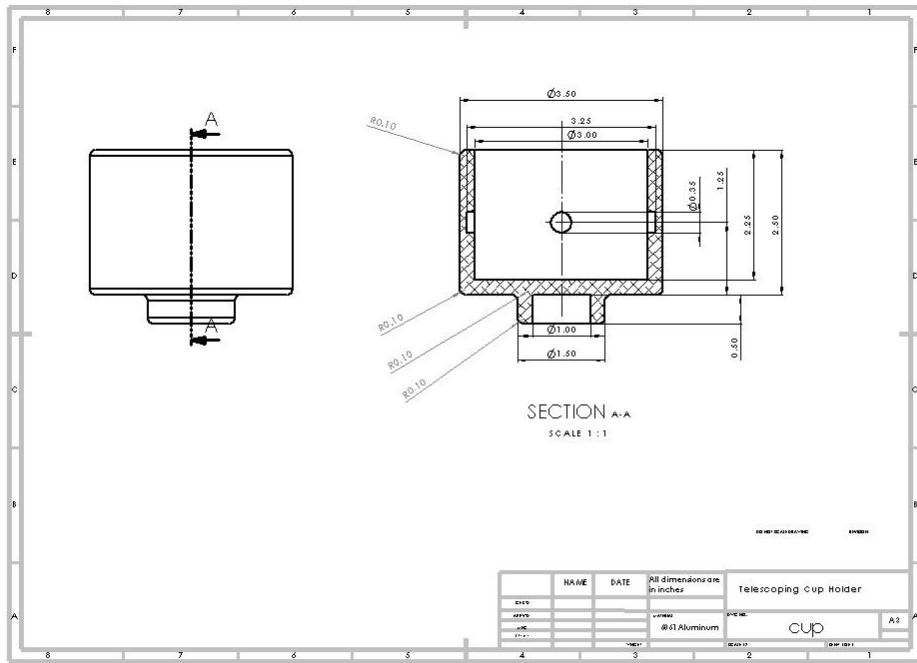

Figure 12: Cup Holder Insert Drawing

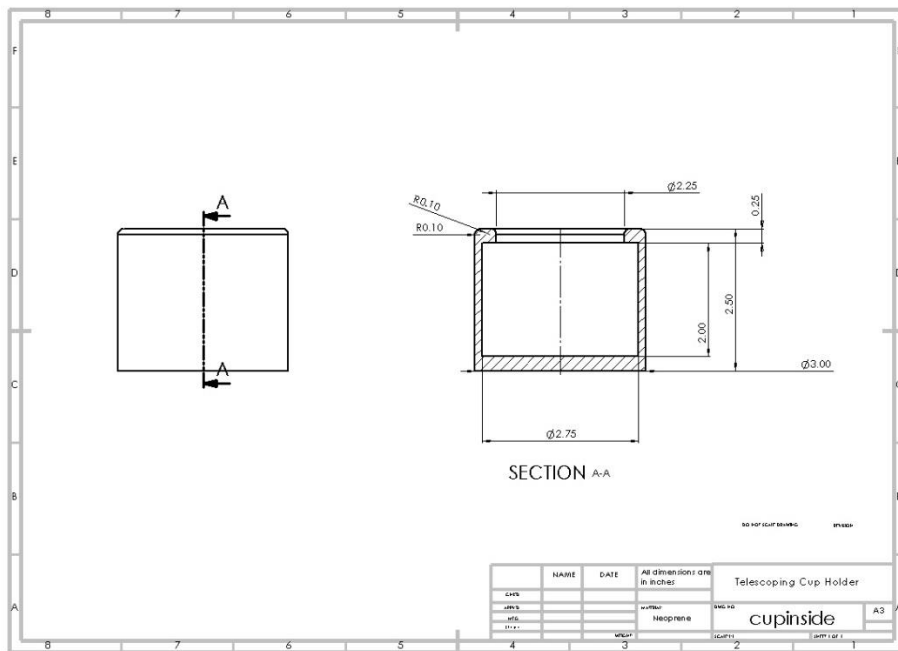

Figure 13: Small Shaft Drawing

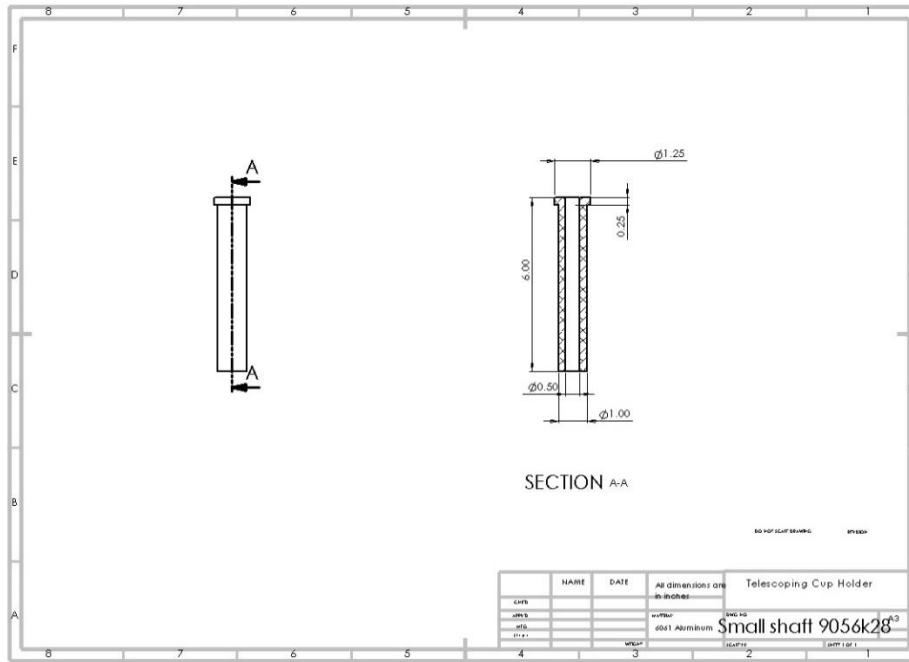

Figure 14: Mid Shaft Drawing

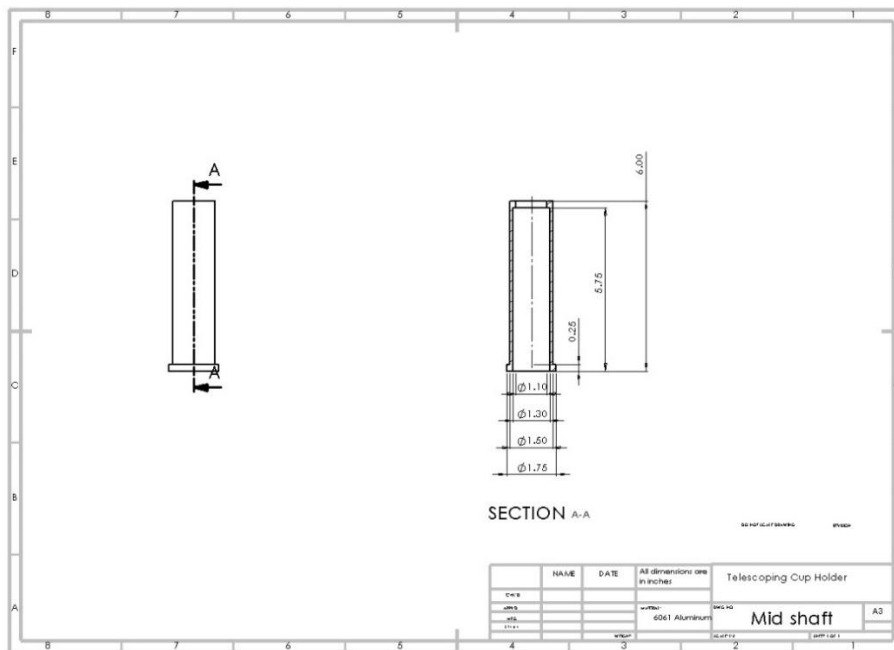

Figure 15: Big Shaft Drawing

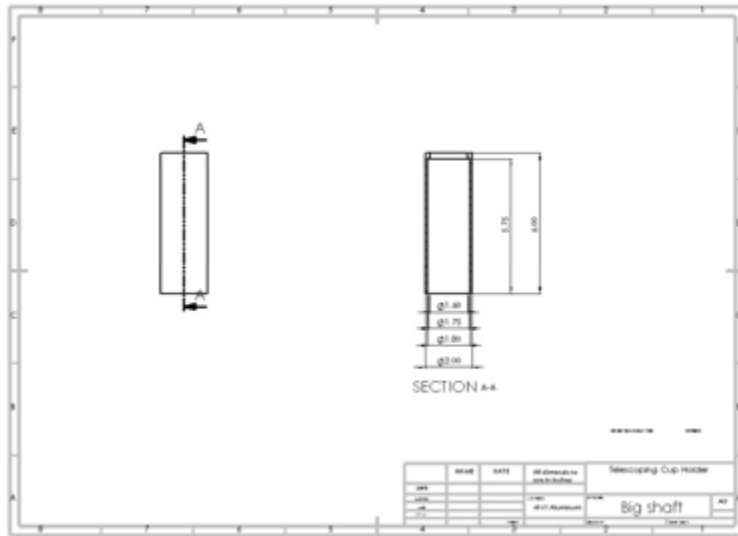

Figure 16: Bottom of the Base Drawing

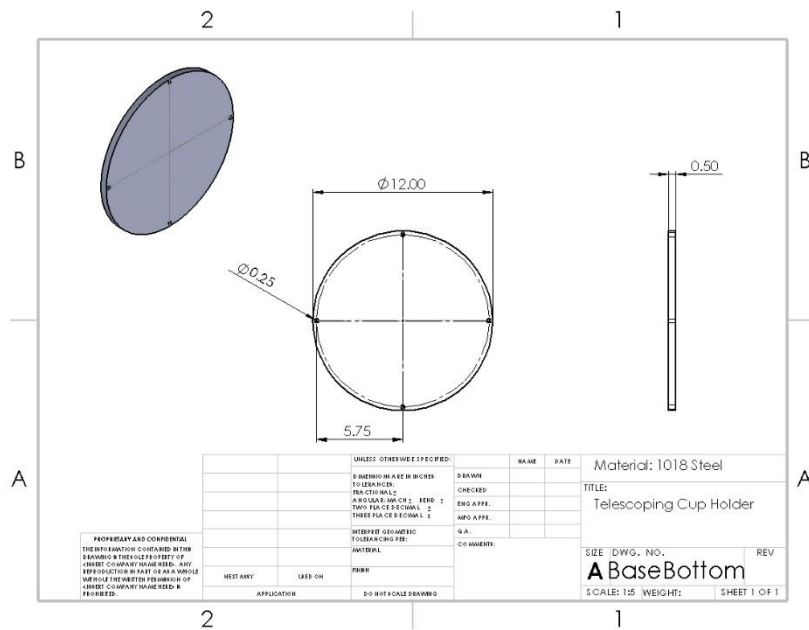
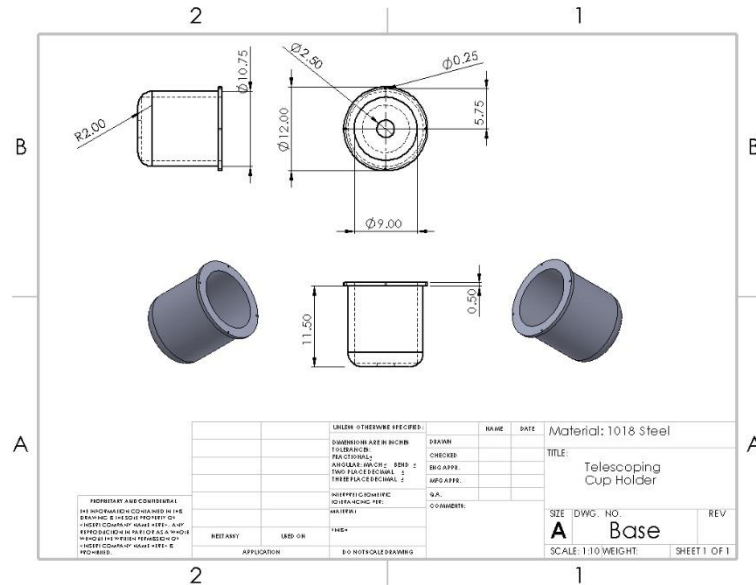

Figure 17: Base Drawing



<http://www.mcmaster.com/#9434k36/=14hkx2j> Drawing for Springs from McMaster

<http://www.mcmaster.com/#6261k171/=14hkx2b> Drawing for Chain Drive from McMaster

4.4 DESCRIPTION OF THE DESIGN RATIONALE FOR THE CHOICE/SIZE/SHAPE OF EACH PART

4.4.1 General Design Rationale

The sizes of each shaft is different so that the larger shaft encapsulates the smaller shaft. The bottom lip of the smaller shafts pulls the larger shafts once the smaller shafts are extended. There are two components of the cup holder. The springs are used to push the inner part of the cup (the component that will insulate the drink) and will hold the drink as snug as possible. The outer part of the cup holder will house the springs and the inner component.

4.4.2 Design Rationale by Part Number:

#1 – Screws: $\frac{3}{4}$ " in length, use to attach parts together

#2 – Motion sensor: Attached with an arduino

#3 – Springs 5 springs to push the inner part of the cup to hold the drink as snug as possible

- #4 – Arduino Used to control the device electronically
- #5 – Motor Strong enough to lift 3lbs. in 5 seconds
- #6, 7, 8 – Aluminum rods: 2.00", 1.75", and 1.25" in diameter. Different sizes so that each rod can house the smaller rod
- #9 – Polyethelyne foam roll: Cheap insulating material
- #10 – Chain drive: 3' long, lifts the telescoping arm
- #11 – Bottom base plate: 12" diameter, ½" thick, 4 screws attached
- #12 – Base material: Manufactured base made from 1018 Steel.

4.5 GANTT CHART

[Copy of Gantt Chart - Man Cave Masters.xlsx](#)

MEMS 411 Senior Project

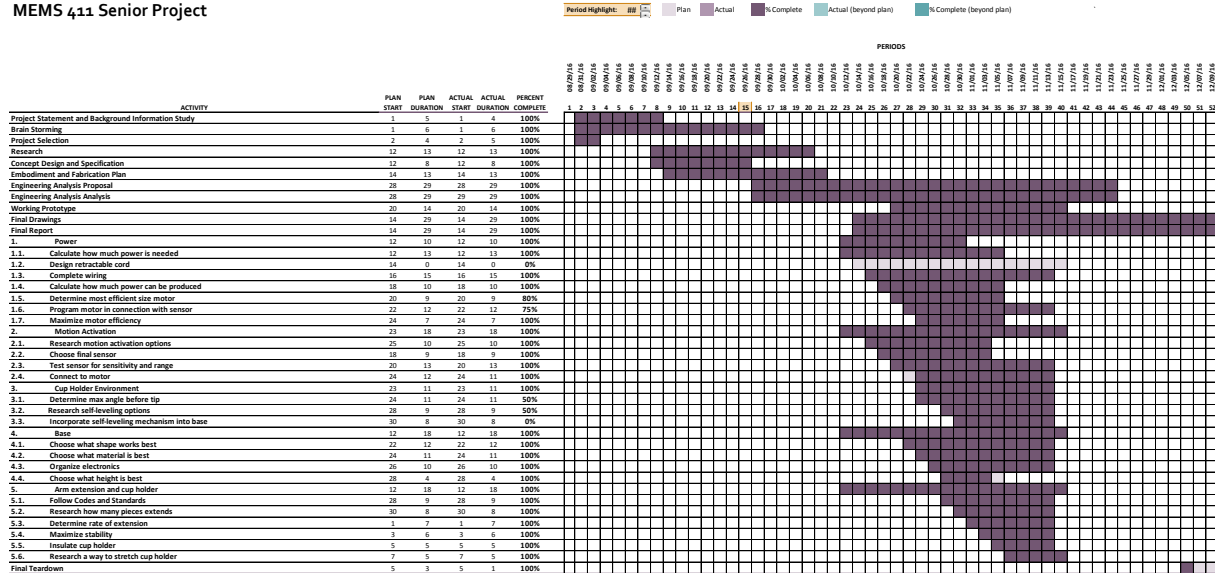

5 ENGINEERING ANALYSIS

5.1 ENGINEERING ANALYSIS RESULTS

5.1.1 Motivation

The focus of our engineering analysis was the stress on the cup holder and arm due to the weight of a beverage once the device is fully extended. This was done by using stress simulation on SolidWorks. Only the small shaft was included in the analysis because each section of the arm is fixed with the tension of the rope.

Motor analysis was also done to see what combinations of RPM and torque would be best to complete the task based on the customer needs. The requirements were to lift a twenty-two ounce beverage 2.5 feet in the air in five seconds or less. A motor that could easily fulfill these requirements was necessary.

A third analysis was done which involved testing the prototype idea. We designed a rope system that would raise each arm of the device, and needed to test this idea before heading into production. If the first prototype failed to demonstrate that the basic motion was possible we needed to know as early as possible. We also were concerned about points of friction and rope selection.

5.1.2 Summary statement of analysis done

Engineering analysis was done on the motor to see how much power was needed to lift a mass and how much power our motor had. The relevant engineering equation used were

$$\text{Work} = \text{Power} * \text{Time} \quad (1)$$

$$P = I * V \quad (2)$$

$$P_{\text{out}} = \tau * \omega \quad (3)$$

Using these equations we found that in order to meet the customer needs stated in the previous section that the required power was 0.93 W. A motor was required that could easily accomplish this task while overcoming issues that we may encounter during production. With this in mind, we chose a motor that would provide more than enough power, and the P_{out} from the motor is 4.8W. A series of gears could be used to reduce the power output if necessary.

Engineering analysis was also done for the material stress check. We concluded that PLA was a suitable material. There were no signs of the cup holder breaking due to stress from a load of twenty-two ounces. The highest stress concentrations were due to the smallest hole, but it was determined that the material wouldn't yield.

In order to test the prototype design, we constructed a primitive example using PVC pipe. We drilled holes into the pipe and fed string through the holes in a way that matched our design idea. This

first prototype successfully demonstrated the basic motion so we knew we could continue with a second prototype.

Figure 18: Stress Analysis

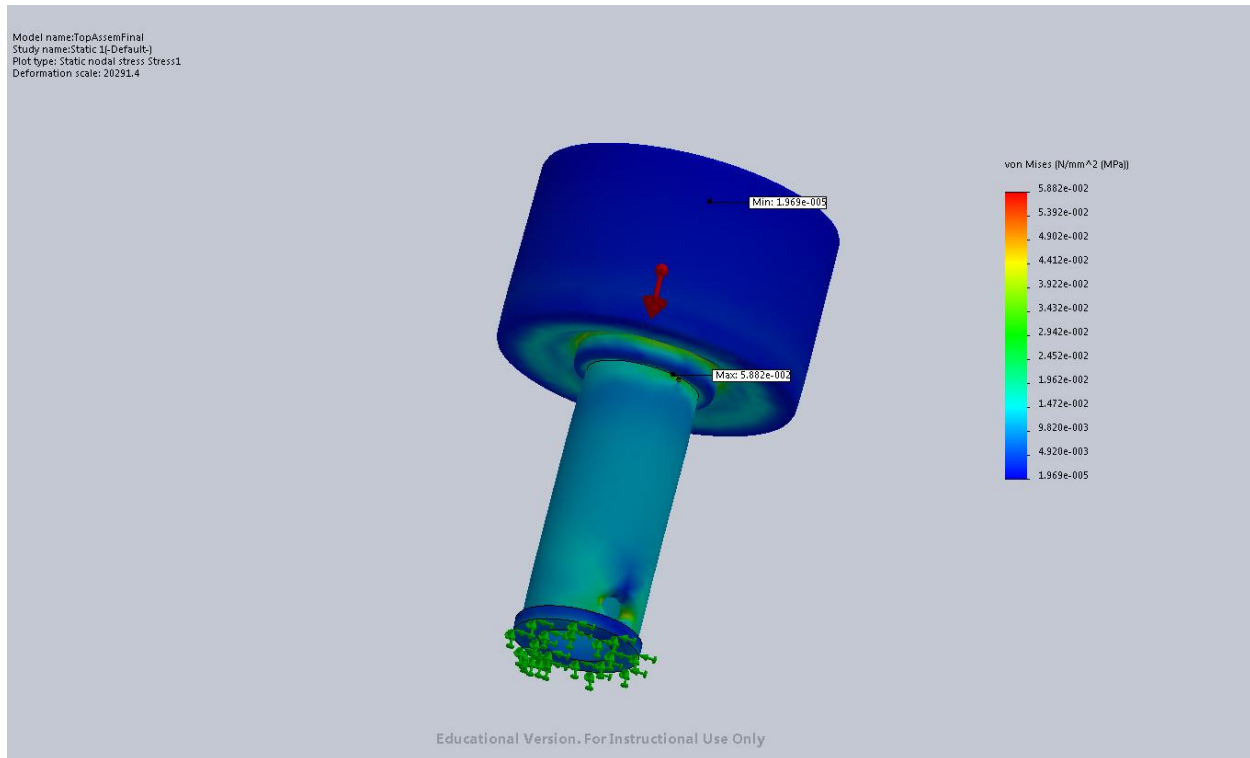

5.1.3 Methodology

The smallest shaft was modeled on SolidWorks, it was fixed at the bottom, and twenty-two ounces were added on the cupholder, in the form of a distributed force. The analysis dictated that PVC was a useable material, and an alpha prototype was created out of PVC. The prototype was created manually, and it was difficult to raise the smallest shaft; therefore, analysis was done using PLA material and the beta prototype was built using PLA. The alpha prototype was also useful to prove that the rope system could successfully raise a 1-piece telescoping arm. Analysis on the motor was done by hand. A motor with superior specs was ordered due to the fear of the motor not being able to raise the cupholder.

5.1.4 Results

The results of our analysis study dictated that PVC was a useable material, although it was difficult to lift once the alpha prototype was built. This makes sense because the analysis was only done with having weight on the smallest shaft. The friction force due to the rope in the system was not taken into account. Although the motor was very strong, a motor with less RPM's but more torque is desired due to how quick the device extends.

The alpha prototype also allowed us to select the rope that we used. Initially we tested a thicker rope that we liked because of its durability. This rope got caught and had an extreme amount of friction. As a result we opted for a thinner rope that has held up through many tests.

5.1.5 Significance

The results will dictate what material will be used on the final prototype. Dimensions were limited to the 3D printing machines that were available. In particular, the analysis was used to compare PVC and PLA as candidate materials. Given that both materials were suitable, PLA was chosen because it is lightweight, durable, cheap, and easy to work with.

A motor with superior specs was chosen due to the fear of the motor being too weak. We were concerned that some motors would be able to extend the arm, but would not be able to do it within the 5-second time frame that we required. By sizing the spool appropriately, we were able to achieve a quick extension and retraction.

The alpha prototype was vital in our design decision process. Before making this model, we were debating between a telescoping design and a scissor lift. While we liked the sleekness of the telescoping design, we had feasibility concerns. Given that we could successfully model a 3-part telescoping model with PVC, we were encouraged to move forward with the telescoping design.

5.1.6 Summary of code and standards and their influence

Our codes and standards established the restrictions on an aerial lifting mechanism. Luckily, our lift would not be carrying a human being so most of the standards do not apply. The biggest issue that applied to our design was the issue of stability. The standard gave a requirement for stability when the system is fully extended. To summarize, after the system reaches its maximum height, it needed to be able to withstand a certain degree of force. For the purposes of our standard, this mainly dealt with wind power so that the system would not tip over in high winds. For our system, we simply provided a force to the side of the system when it was fully extended. We added a heavy base to the bottom of the system that satisfied the standard.

5.2 RISK ASSESSMENT

5.2.1 Risk Identification

We identified six possible risks that could play a role in the failure of the device. These risks included

1. Ineffective Insulation
2. Stability
3. Part Ordering
4. Not Enough Power
5. Motion Sensor Integration
6. Rope System Failure

5.2.2 Risk Impact or Consequence Assessment

Our group was provided with an excel spreadsheet that would create a risk assessment map based upon input values that we established for each risk. The excel spreadsheet can be found at this link: [Copy of Risk Assessment.xlsm](#)

Risk Assessment Tool
Use to identify, assess and take action to reduce risk



Enterprise Risk Services
3015 SW Westview Boulevard
Corvallis, OR 97331
risk.oregonstate.edu

Purpose of Risk Assessment: Departmental _____
 Department/Unit Name: Mechanical Engineering _____
 Administrative Structure: Center Design _____
 Completed By: Connor G. Mills, Chris Messer _____
 Date Completed: 11/15/2016 _____
 Date of Next Risk Assessment: _____

Click to update final copy

What is the risk?	Describe the identified risk	How is risk currently managed**	Comments/Concerns	Impact	Likelihood	Risk Calculations			Do you need to do anything else to reduce or control the risk?	Responsible Person/Job Title	Target Completion Date
						Impact	Likelihood	Risk Score			
Example: Serving food	Preparing and serving food to 100 people during event Food is not being prepared or served by hand	Students are required to wash their hands before handling food On-site refrigerator for proper food storage Ensuring all equipment, dishes and utensils are clean and sanitary before use.	Some people attending event may have food allergies. Want to ensure food is cooked adequately	Moderate	Low-Medium	1	2	8	Group signage that warns of food allergies and place in front of food station. Purchase thermometers to check the food temperature.	John Smith	12/30/2014
Not Enough Power	Motor cannot fully extend arm with beverage	Ordered a high-powered motor. Can adjust with speed dial	Could also modify final 3D printed design to be lighter/smaller as needed	Significant	Low-Medium	4	2	8	Label with appropriate hazard tag	Charlie	
Part Ordering	Proper allocation of funds for parts	Updating and referring to the Cost-Effective handbook	We are on track to be under budget	Mild	Low	2	1	2	Still have a lot of flexibility	Charlie	
Motor System Failure	Rope breaks or comes off track or gets tangled	Constant tension and strong smooth rope	Would be very difficult to replace once rope is tangled	Catastrophic	Medium	5	3	15	Get PVC prototyper working	Richard	
Surface Irritation	Skin doesn't stay flat cold	Open system with loose material	Shouldn't need more than 30 reviews	Mild	Medium	2	3	6	Shouldn't generate heat	Eric	
Difficulty	Use of ropes during extension or retraction	Good tension between rope and shafts, smooth rope motion	Important for prototyper extension on a hot liquid surface	Substantial	Medium	2	3	6	Maybe have to make gears to hold the shafts	Richard	
Switch Sensor Integration	Switch sensor either works when you dip seat in it or is difficult to activate	Ordered a reed sensor that can be turned	May need to replace entry part of the reed sensor in order for it to be effective	Significant	Low	4	1	4	Needs to be consistent	Eric	
						100%	100%	100%			
						100%	100%	100%			
						100%	100%	100%			
						100%	100%	100%			
						100%	100%	100%			
						100%	100%	100%			
						100%	100%	100%			
						100%	100%	100%			
						100%	100%	100%			
						100%	100%	100%			
						100%	100%	100%			

*Possible risks may include: injuries, damage to reputation, property damage, accidents, student use, serving food
 **Methods to manage risks may include: insurance, warnings, signage, arranging for security, policies and procedures, training

This figure shows the resulting risk heat map

Figure 19: Risk Heat Map

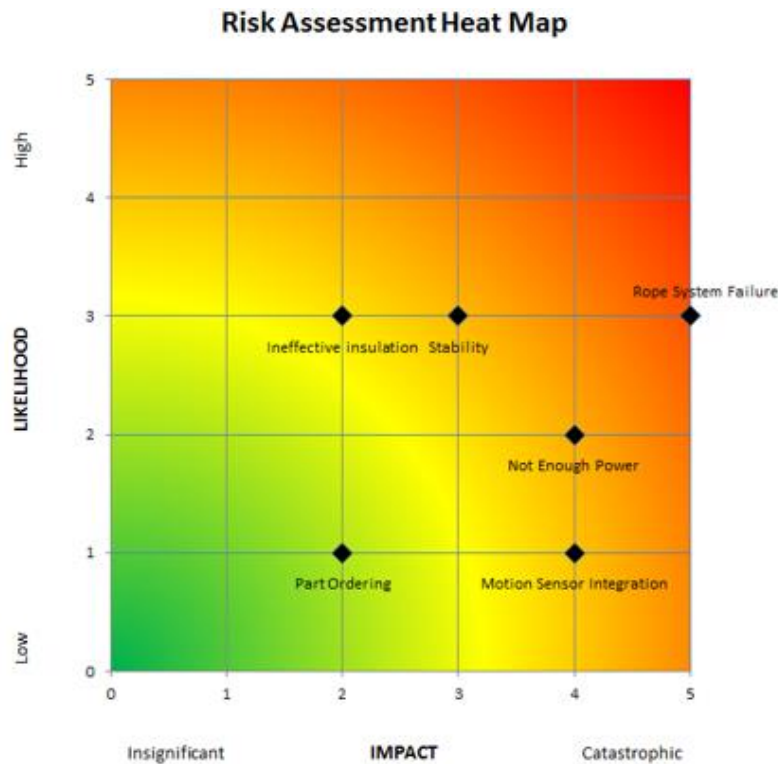

5.2.3 Risk Prioritization

From the heat map we were able to prioritize each risk. We assumed that the parts we ordered would be delivered on time and that they would be the parts we needed. Fortunately, this proved to be a low risk since we had no problems. If we had had more time, we would have reordered a different motor or stronger string, but for the purposes of our prototype the parts met our requirements.

As you can see from the heat map, rope system failure has the highest likelihood and highest impact. In fact, during our testing phase we encountered a rope failure. We had to deconstruct the system and supply a new rope. This took over an hour and if a customer encountered this failure they would need to send the entire system back to us which would not be ideal. If we were to continue this project we would need to research the highest quality of string that could withstand high levels of friction for long periods of time. For the purposes of this prototype we simply used string we found in the basement of the MEMS department.

6 WORKING PROTOTYPE

6.1 AT LEAST TWO DIGITAL PHOTOGRAPHS SHOWING THE PROTOTYPE

The following are both front views of the final prototype. On the left, the arm is retracted and the door is closed. On the right, the arm is extended, and the door is open.



Figure 20: Front Assembly View with Door Closed and Arm Retracted.

This image depicts the final assembly from the front with the door closed, and the arm is retracted. In this state, your beverage would be out of the way, and held very sturdily. We are confident that kids, pets, or errant feet movement would not cause a spill. The box shape is also convenient as a furniture item.



Figure 21: Front Assembly View with Door Open and Arm Extended.

This

image depicts the final assembly with the arm extended to its max height of 27 inches. The multi-colored shafts highlight some of the personalization aspects of this device. The door would most likely be left off of the version for customers but it was necessary for assembly and tinkering. The shape of the base could also be changed, but its main purpose is to house the motor and other electronics.

6.2 A SHORT VIDEOCLIP THAT SHOWS THE FINAL PROTOTYPE PERFORMING

The following clip includes the performance specifications, demonstrations/measurements of our working prototype (3 minutes in length):

<https://youtu.be/TUMKSmBc-uE>

The following is a brief clip of our prototype operating (15 seconds in length):

<https://youtu.be/hcmdrgXjgno>

6.3 AT LEAST 4 ADDITIONAL DIGITAL PHOTOGRAPHS AND THEIR EXPLANATIONS



Figure 22: Inside of the Base

The image to the left shows the inside of the base. The platform at the top houses the motion sensor, which was uninstalled when this photo was taken. Directly below that is a platform which houses both the Arduino and the breadboard. There is a hole above this platform which allows the wire to exit the base and be plugged into an outlet. The front platform houses the motor driver. The high platform to the right houses the motor, which is held in place by two large round head screws. A hexagonal motor shaft extension, which was force fitted to the spool, was added to the motor shaft. By changing the spool size, the extension/retraction speed could be changed without modifying the Arduino code.



Figure 23: Location of Motion Sensor

The image to the left depicts the motion sensor on the elevated platform within the base. We were initially concerned with transportation knocking this device from its platform, but by drilling a hole, we were able to feed the wire through the platform (not shown) to keep it in place. The hole directly above the sensor allows the motion sensor to detect a hand wave above the prototype. With the door closed the motion sensor would only see movement above the cup holder.

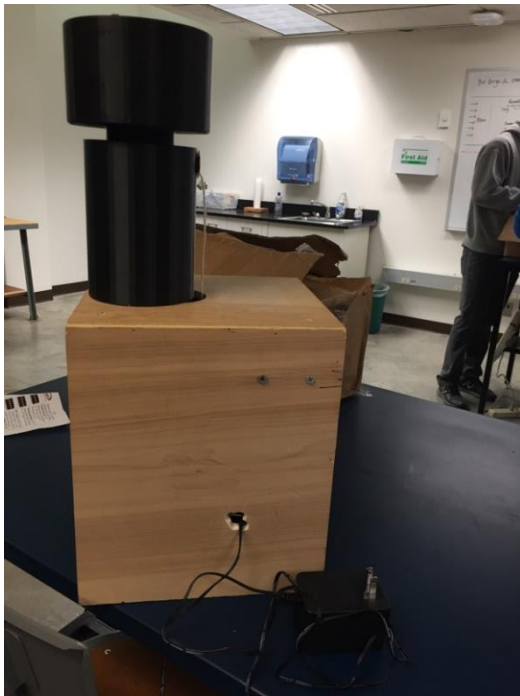

Figure 24: Side View Showing Cord Hole

The image to the left shows a side view of the prototype. The screws shown here are used to hold the motion sensor platform in place. The hole which connects the electronics to their power source is also depicted. This photo shows that the rope system can be seen from the outside of the system.



Figure 25: Insulated Holder

The photo to the left shows a top view of the cup holder. 8 springs are used to hold 4 pieces of insulation in place. A standard size can or bottle requires only slight compression of the springs, whereas 16-28 ounce containers require greater spring compression. This photo also highlights the personalization capabilities that would be vital to marketing this product.

7 DESIGN DOCUMENTATION

7.1 FINAL DRAWINGS AND DOCUMENTATION

7.1.1 Engineering drawings

That includes all CAD model files and all drawings derived from CAD models. *Include units on all CAD drawings.* See Appendix C for the CAD models.

7.2 FINAL PRESENTATION

7.2.1 A link to a video clip

Prior to our external review board presentation, we sent the reviewers the following video:

<https://www.youtube.com/watch?v=7pkJArQo4P0>

7.3 TEARDOWN

TEARDOWN TASKS AGREEMENT

PROJECT: Man Cave NAMES: ERN INSTRUCTOR: Professor Malast
Eric Newby
Charlie Morrow, CM
Richard Pajarillo R.P.

The following teardown/cleanup tasks will be performed:

- Electronics separated and taken by Charlie
- Shafts taken by Eric, others returned to basement.
- PVC pipe returned to basement
- Shelf cleaned
- String returned
- Test batteries and Motors returned
- Base placed in basement

Instructor comments on completion of teardown/cleanup tasks:

OK. M.J.

Instructor signature: Mark J. Jabity; Print instructor name: JAKIELA

Date: 12/7/2016

(Group members should initial near their name above.)

8 DISCUSSION

8.1 USING THE FINAL PROTOTYPE PRODUCED TO OBTAIN VALUES FOR METRICS, EVALUATE THE QUANTIFIED NEEDS EQUATIONS FOR THE DESIGN. HOW WELL WERE THE NEEDS MET? DISCUSS THE RESULT.

Metric number one, the device was to extend 2.5 feet in length, was fully achieved. The device extends over 2.5 feet when a beverage is in the cup holder.

Metric number two, the time for the device to fully extend, was accomplished. The device was to fully extend in 5 seconds or less, and our apparatus fully extended in approximately 1 second.

Metric number three, the device was to be battery and cord powered, was not fully met. We decided to make our device non-portable; thus, making it only cord powered.

Metric number four, the device was to work on carpet and hardwood, was achieved due to making the device non-portable.

Metric number five, the device should fits most cup sizes, was resolved. The cup holder is able to house a beverage that is up to 3.68 inches in diameter.

Metric number six, safety and stability of the device, was met. The pinching of a finger between the cup holder and the shafts were mitigated. Tracks were added into the shafts to reduce shaft bending.

Metric number seven, the extension/retraction noise of the device, was not fully accomplished. The extension of the shafts had some noise, but the cup holder would slam down due to the force of the motor and gravity.

Metric number eight, mutable cheer, was not met. We did not add this feature.

Metric number nine, sleekness, was also not met. We decide to go with a more complex look for our device, although the simplicity of the parts give it a certain sleekness.

8.2 DISCUSS ANY SIGNIFICANT PARTS SOURCING ISSUES? DID IT MAKE SENSE TO SCROUNGE PARTS? DID ANY VENDOR HAVE AN UNREASONABLY LONG PART DELIVERY TIME? WHAT WOULD BE YOUR RECOMMENDATIONS FOR FUTURE PROJECTS?

Parts sourcing for the final prototype was crucial. Blocks of wood to house the electronics of the device, as well as the screws necessary to put the base together were found in the basement; a hexagonal motor shaft extension and string was also found. Scrounging parts made sense for our alpha prototype because string and PVC pipes were used to understand the basic motion of our device. No vendors did not have an unreasonably long part delivery time. As for recommendations for future projects, pick a project that you are passionate about. Order your parts as early as possible, and assemble your prototype as soon as possible. This will give you the max amount of time to test and debug your device.

8.3 DISCUSS THE OVERALL EXPERIENCE:

8.3.1 Was the project more of less difficult than you had expected?

The project was more difficult than we expected. We did not anticipate all of the complications that extending a three-piece telescoping arm against gravity with the weight of a drink on it. Tight clearances are needed for stability, yet the arms and ropes must move freely between one another. A thin string was needed so that it wouldn't bind but durability was also very important. 3D printing, which was integral to our project, was slower than anticipated and often not available due to high demand. The motor needed to be propel the arm at the right speed, and also be able to lift heavy drinks.

8.3.2 Does your final project result align with the project description?

Yes. The cup holder itself can fit most sizes, and holds them snugly enough so that they don't budge even with the quick extension and retraction. As it stands, the motion sensor is not working, but when it did we were able to extend the arm consistently with a wave over the device. The telescoping motion desired was achieved, and the device is quite sturdy when retracted.

8.3.3 Did your team function well as a group?

Yes. We were able to work around different class and exam schedules to progress according to our Gantt chart. All members brought differing skill sets and ideas to the table.

8.3.4 Were your team member's skills complementary?

Yes. Arduino programming, SolidWorks modeling, and woodworking/assembly skills all had to be called upon to complete the project.

8.3.5 Did your team share the workload equally?

Yes. With three members, everyone spent a considerable amount of time on the project.

8.3.6 Was any needed skill missing from the group?

Although much of the work done was relatively new to us, we found that with the help of Chase, Mr. Tapella, and Professors Woodhams, Malast, and Jakiela, everything was manageable.

8.3.7 Did you have to consult with your customer during the process, or did you work to the original design brief?

We worked with the initial design brief, and used our assessment of relative importance of design criteria to make key decisions.

8.3.8 Did the design brief (as provided by the customer) seem to change during the process?

Yes, it changed slightly. While we were initially hoping to make portability an option, we omitted this feature due to time constraints and concerns about the life and weight of a battery. We also hoped for longer arm pieces, but with our choice of 3D printing we were unable to accomplish this.

8.3.9 Has the project enhanced your design skills?

Through this project, we have gained experience with programming, modeling, 3D printing, machining, and selecting/operating motors. Although we were familiar with group work for classes, a semester long project required additional planning and collaboration as well.

8.3.10 Would you now feel more comfortable accepting a design project assignment at a job?

Yes. This project gave us the experience of working in a group, which is beneficial for another design project assignment.

8.3.11 Are there projects that you would attempt now that you would not attempt before?

We were happy with how easy it was to go from a Solidworks design to a prototype with the use of 3D printers. Although we would have liked to be able to build longer shafts with them, we would certainly feel more comfortable using this technology for future projects.

9 APPENDIX A - PARTS LIST / BILL OF MATERIALS

	<i>Part</i>	<i>Supplier Part Number</i>	<i>Color, TPI, other part IDs</i>	<i>Quantity</i>
1	Motion Sensor	ESHCSR501	Arduino Attachment	1
2	Arduino	1050-1024-ND	Uno	1
3	Motor	G1611267	Black	1
4	Motor Driver	9056k76	6" Length	1
5	Ropes	541-098 386-523	2 Ropes	1
6	Electronics	12263055	Power source, wires, connector	1
7	Connectors	9056k81	6" Length	1
8	Small Shaft Final	N/A	Yellow PLA	1
9	Mid Shaft Final	N/A	Grey PLA	1
10	Big Shaft Final	N/A	Black PLA	1
11	Spool Final	N/A	Blue PLA	1
12	Cup Final	N/A	Black PLA	1
13	Steel Compression Springs	9657K49	.56"/1" compression	8
14	Wooden Box (used for Base)	N/A		1

15	Brass Grommet	9604K26	1.05" OD	1
16	Roundhead Screw	Unknown	Found in Basement	2

10 APPENDIX B - CAD MODELS AND DRAWINGS

Attached are the drawings and models of all of the final parts that were 3D printed for the prototype. These are also available in our File Exchange.

[Senior design\Final Models and Drawings](#)

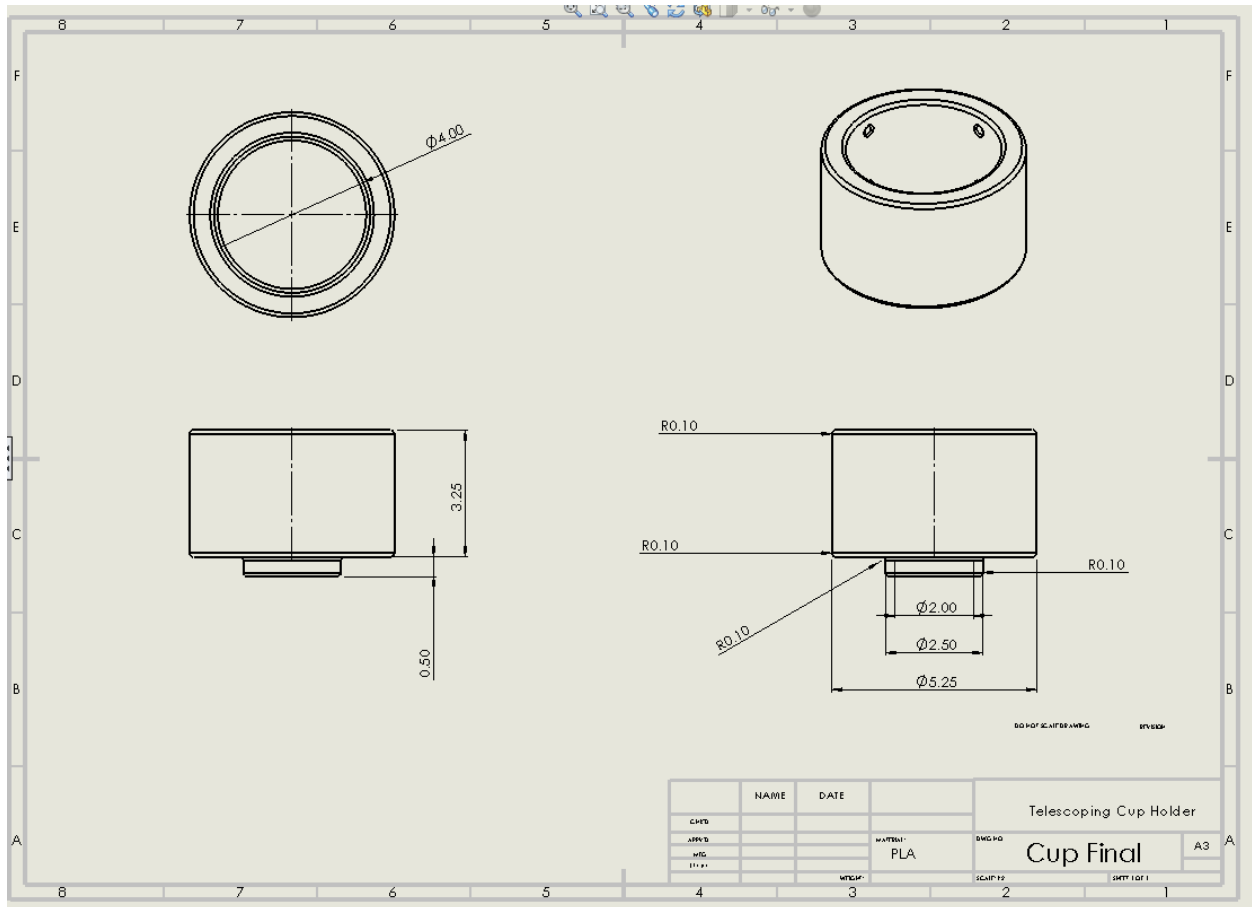

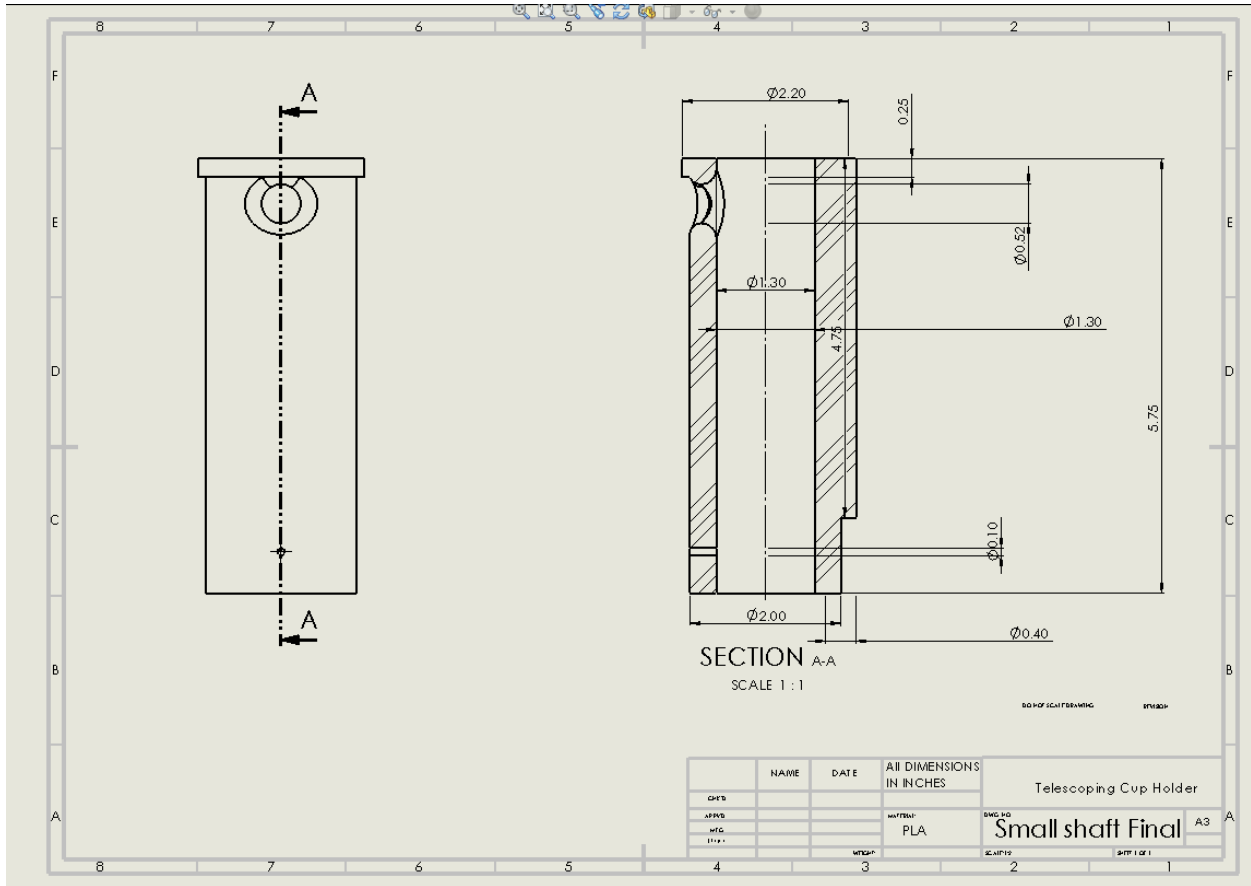

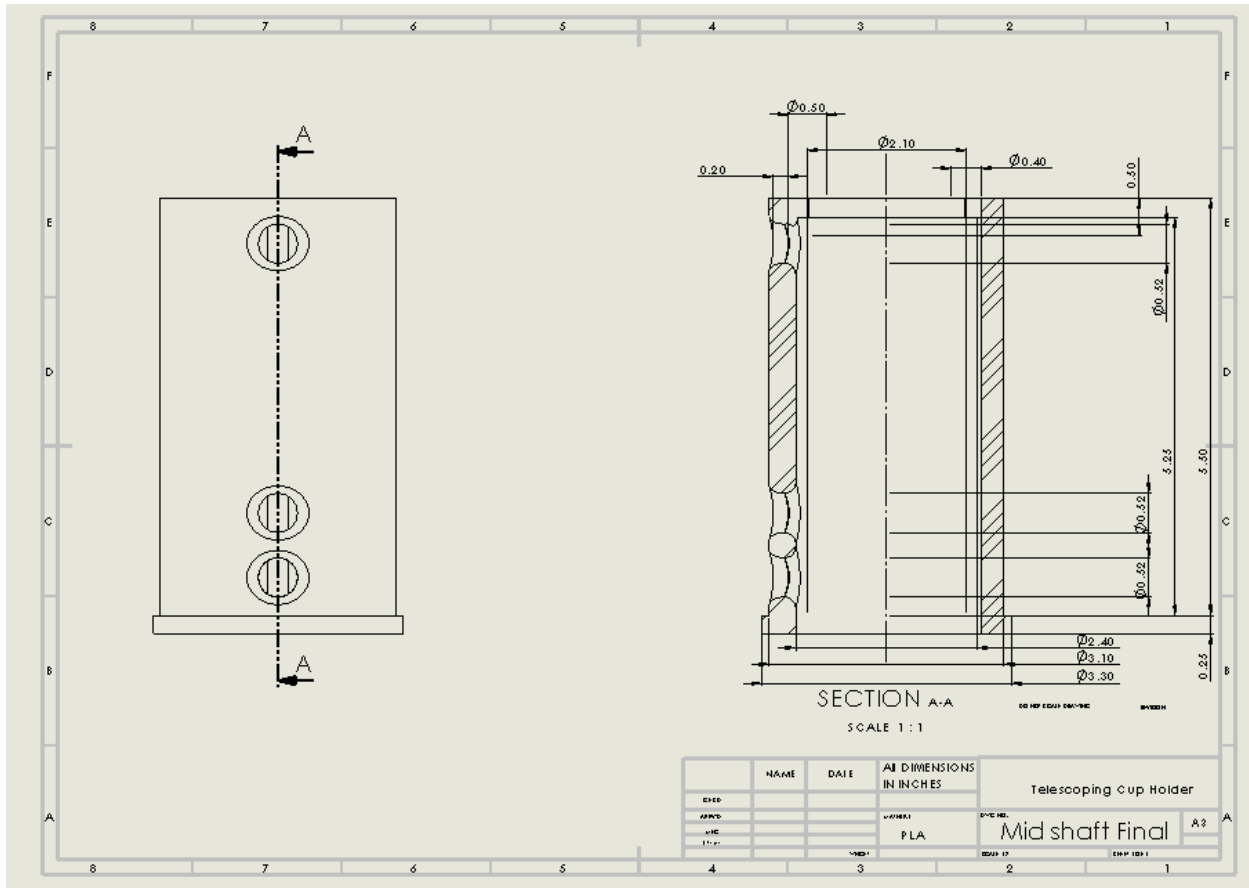

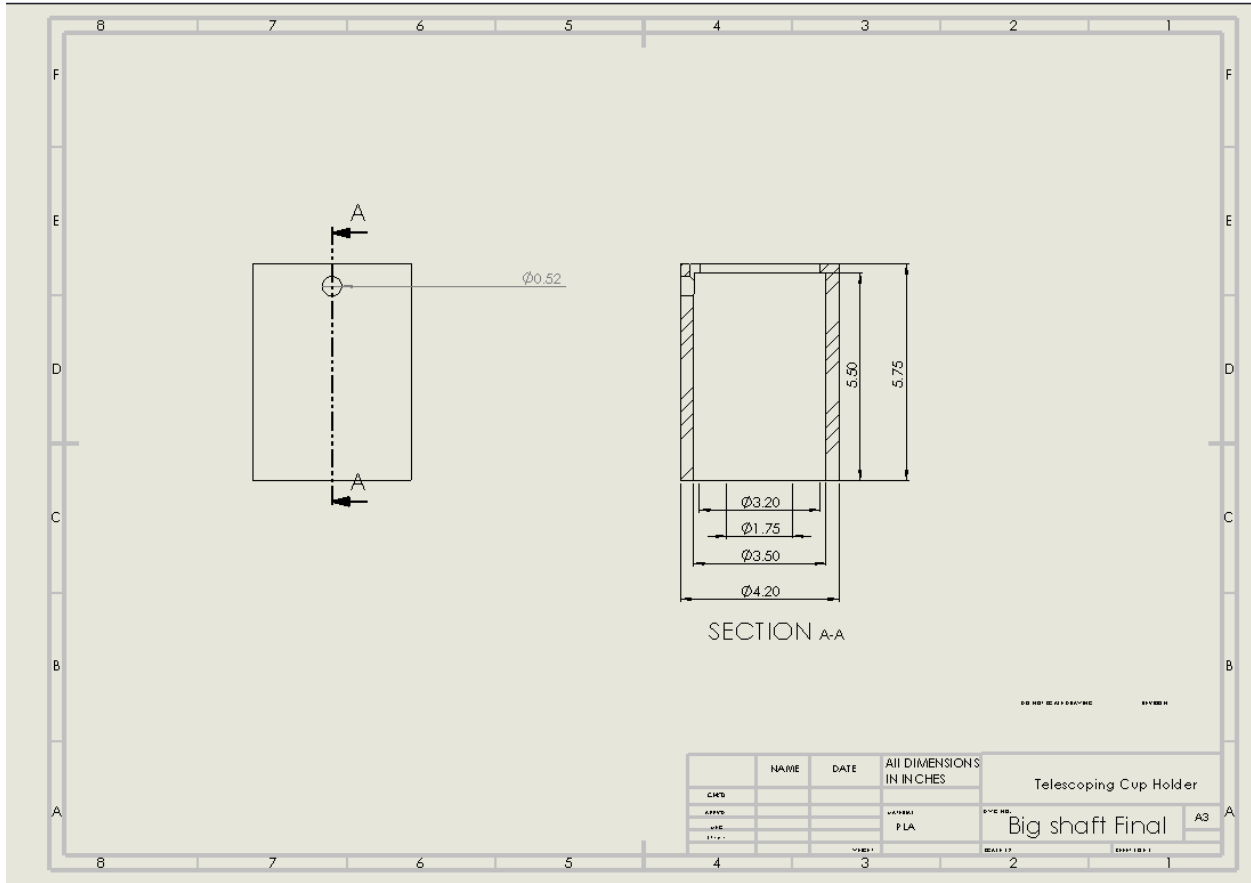

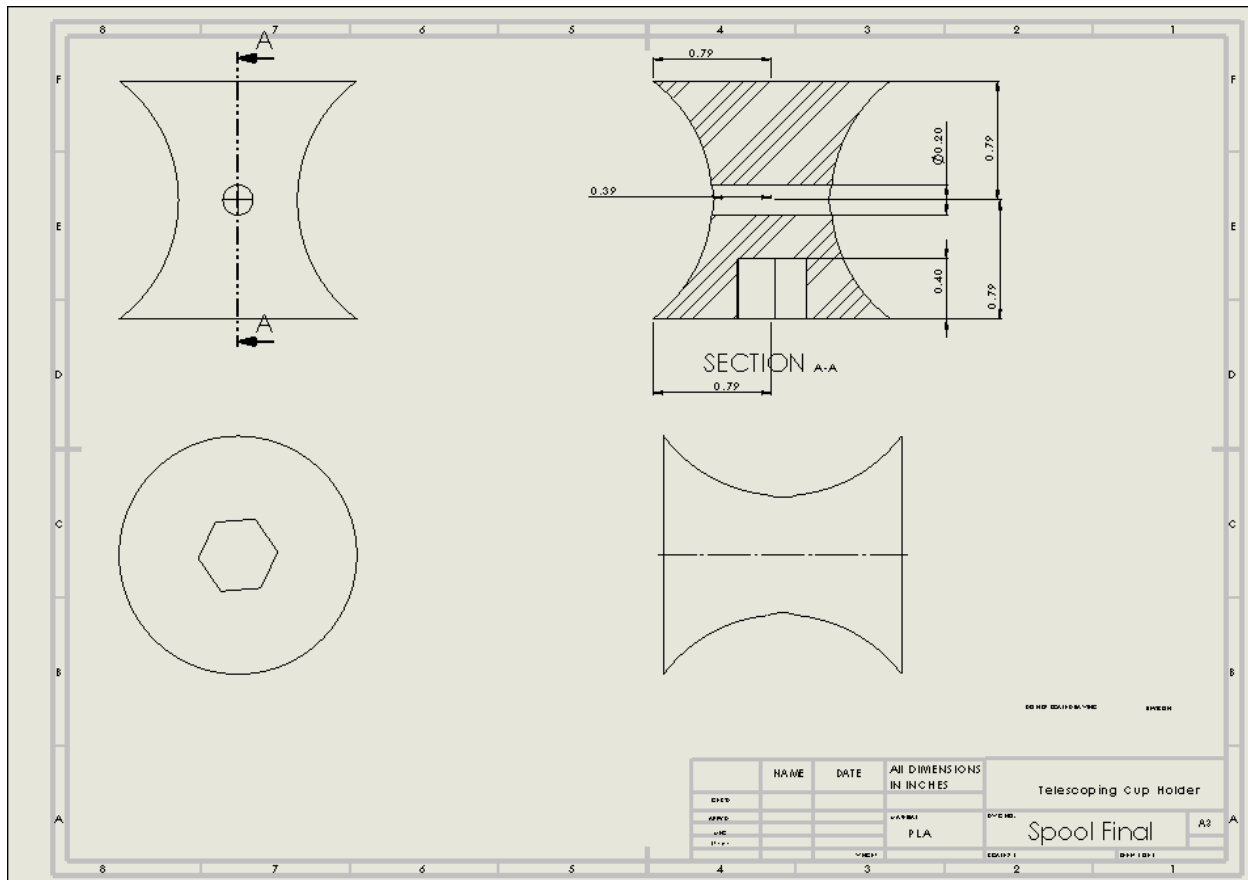

11 ANNOTATED BIBLIOGRAPHY

"SAFETY REQUIREMENTS FOR LIFTING TABLES - PART 2: LIFTING TABLES SERVING MORE THAN 2 FIXED LANDINGS OF A BUILDING, FOR LIFTING GOODS WITH A VERTICAL TRAVEL SPEED NOT EXCEEDING 0,15 M/S," PREN 1570-2 - 2014: European Committee for Standardization, from <http://standards.globalspec.com/std/1678836/cen-pren-1570-2>.

Our standard was mainly for scaffolding, not beverage containers. Given the uniqueness of our project, there was not a more applicable standard available. Although requirements for speed and safety of scaffolding do not inherently apply to powered cup holders, we found the considerations for speed and stability under harsh conditions applicable as we designed our device.

12 ATTACHMENT 1 – STRESS ANALYSIS REPORT

[Stress Analysis-Static 1.docx](#)