

Washington University in St. Louis

Washington University Open Scholarship

Mechanical Engineering Design Project Class

Mechanical Engineering & Materials Science

Fall 2016

Group F: Cell Phone Forearm Holder

Jacob Aley

Washington University in St. Louis

Emily Groth

Washington University in St. Louis

Sinclair Hodge

Washington University in St. Louis

Follow this and additional works at: <https://openscholarship.wustl.edu/mems411>



Part of the [Mechanical Engineering Commons](#)

Recommended Citation

Aley, Jacob; Groth, Emily; and Hodge, Sinclair, "Group F: Cell Phone Forearm Holder" (2016). *Mechanical Engineering Design Project Class*. 47.

<https://openscholarship.wustl.edu/mems411/47>

This Final Report is brought to you for free and open access by the Mechanical Engineering & Materials Science at Washington University Open Scholarship. It has been accepted for inclusion in Mechanical Engineering Design Project Class by an authorized administrator of Washington University Open Scholarship. For more information, please contact digital@wumail.wustl.edu.



Washington University in St. Louis

SCHOOL OF ENGINEERING & APPLIED SCIENCE

MEMS 411

Senior Design Final Report

Cellphone Forearm
Holder

Emily Groth
Jacob Aley
Sinclair Hodge

The objective of this project was to design a cell phone holder, such that the phone can be used on the go with one hand. We designed a holder that fits around the forearm. The phone attaches to a helical track, so it can travel up and down the forearm, and stay at the top or bottom of the track indefinitely.

TABLE OF CONTENTS

List of Figures	4
List of Tables	5
1. Introduction.....	6
1.1. Project problem statement.....	6
1.2. List of team members.....	6
2. Background Information Study – Concept of Operations.....	6
2.1. A short design brief description that describes the problem	6
2.2. Summary of relevant background information	6
2.2.1. Closest Competitors	6
2.2.2. Significant Risk.....	8
2.2.3. Relevant Codes and Standards.....	8
3. Concept Design and Specification – Design requirements	9
3.1. Operational requirements allocated and decomposed to design requirements.....	9
3.1.1. Customer Interview Questions.....	9
3.1.2. List of identified operational and design requirements.....	10
3.1.3. Functional allocation and decomposition.....	11
3.2. Four concept drawings	12
3.3. concept selection process.....	15
3.3.1. Preliminary analysis of each concept’s physical feasibility based on design requirements, function allocation, and functional decomposition	15
3.3.2. Concept scoring.....	16
3.3.4. Final summary Statement.....	18
3.4. Proposed performance measures for the design.....	18
3.5. Design constraints.....	18
3.5.1. Functional	18
3.5.2. Safety	18
3.5.3. Quality.....	18
3.5.4. Manufacturing.....	18
3.5.5. Timing.....	19
3.5.6. Economic	19
3.5.7. Ergonomic.....	19
3.5.8. Ecological	19

3.5.9.	Aesthetic	19
3.5.10.	Life cycle	19
3.5.11.	Legal	19
4.	Embodiment and fabrication plan	20
4.1.	Embodiment drawing	20
4.2.	Parts List	21
4.3.	Draft detail drawings for each manufactured part.....	22
4.4.	Description of the design rationale for the choice/size/shape of each part	26
4.5.	Gantt chart.....	26
5.	Engineering analysis	26
5.1.	Engineering Analysis PRoposal.....	26
5.2.	Engineering analysis results.....	26
5.2.1.	Motivation.....	26
5.2.2.	Summary statement of analysis done.....	27
5.2.3.	Methodology	29
5.2.4.	Results.....	29
5.2.5.	Significance.....	29
5.2.6.	Summary of code and standards and their influence.....	30
5.2.7.	Motion Study Link	30
5.3.	Risk Assessment	30
5.3.1.	Risk Identification.....	30
5.3.2.	Risk Impact or Consequence Assessment.....	31
5.3.3.	Risk Prioritization	31
6.	Working prototype	31
6.1.	A preliminary demonstration of the working prototype	31
6.2.	A final demonstration of the working prototype.....	31
6.3.	At least two digital photographs showing the prototype.....	31
6.4.	A Short video clip link showing prototype performing	33
6.5.	At least 4 additional digital photographs and their explanations	34
7.	Design documentation.....	37
7.1.	Final Drawings and Documentation	37
7.1.1.	ENGINEERING DRAWINGS	37
7.1.2.	Sourcing instructions.....	43

7.2.	Final Presentation.....	44
7.2.1.	EXTERNAL REVIEW BOARD PRESENTATION	44
7.2.2.	LINK TO EXTERNAL REVIEW BOARD PRESENTATION VIDEO	44
7.3.	Teardown	45
8.	Discussion	46
8.1.	Using the final prototype produced to obtain values for metrics, evaluate the quantified needs equations for the design. How well were the needs met? Discuss the result.	46
8.2.	Discuss any significant parts sourcing issues? Did it make sense to scrounge parts? Did any vendor have an unreasonably long part delivery time? What would be your recommendations for future projects?.....	47
8.3.	Discuss the overall experience:.....	48
8.3.1.	Was the project more or less difficult than you had expected?.....	48
8.3.2.	Does your final project result align with the project description?	48
8.3.3.	Did your team function well as a group?	48
8.3.4.	Were your team member's skills complementary?.....	48
8.3.5.	Did your team share the workload equally?.....	48
8.3.6.	Was any needed skill missing from the group?	49
8.3.7.	Did you have to consult with your customer during the process, or did you work to the original design brief?	49
8.3.8.	Did the design brief (as provided by the customer) seem to change during the process?...49	
8.3.9.	Has the project enhanced your design skills?	49
8.3.10.	Would you now feel more comfortable accepting a design project assignment at a job?...49	
8.3.11.	Are there projects that you would attempt now that you would not attempt before?	49
9.	Appendix A - Parts List	50
10.	Appendix B - Bill of Materials	50
11.	Appendix C - CAD Models AND STRESS TEST REPORTS.....	50
12.	Annotated Bibliography.....	50

LIST OF FIGURES

Figure 1: Closest Competitor #1, Patent US 20090321483 A1	7
Figure 2: Closest Competitor #2, Patent US 8662362 B1	8
Figure 3: Concept Design #1	12
Figure 4: Concept Design #2	13
Figure 5: Concept Design #3	14
Figure 6: Concept Design #4	15
Figure 7: Working Assembly with Bill of Materials	20
Figure 8: Working Carriage with Bill of Materials.....	21
Figure 9: SolidWorks Drawing of Wheel with Dimensions	22
Figure 10: SolidWorks Drawing of Carriage with Dimensions.....	23
Figure 11: SolidWorks Drawing of Cellphone Forearm Component with Dimensions	24
Figure 12: SolidWorks Drawing of Cellphone Forearm Component End Component with Dimensions ..	25
Figure 13: SolidWorks Drawing of Phone-to-Carriage Attachment with Dimensions	25
Figure 14: Gantt Chart	26
Figure 15: Static Stress Test Performed on Track	27
Figure 167: Static Torque Test Performed on Keyhole	28
Figure 176: Static Stress Test Performed on Carriage	28
Figure 18: Current Track Design	30
Figure 19: Final Prototype	32
Figure 20: Final Prototype	33
Figure 21: Track and End-Caps	34
Figure 22: Track and Carriage	34
Figure 23: Carriage and Phone Orientation	35
Figure 24: Velcro Holding Carriage at End-Cap	35
Figure 25: SolidWorks Drawing of Variable Radius Holster	37
Figure 26: SolidWorks Drawing of Case-to-Arm Attachment with Dimensions	38
Figure 27: SolidWorks Drawing of Variable Radius Holster End Piece with Dimensions	39
Figure 28: SolidWorks drawing of Final Assembly with Bill of Materials	39
Figure 29: Alternate SolidWorks Drawing of Variable Radius Holster	40
Figure 30: Alternate SolidWorks Drawing of Case-to-Arm Attachment	40
Figure 31: Alternate SolidWorks Drawing of Variable Radius Holster End Piece	41
Figure 32: Alternate SolidWorks Drawing of Case-To-Arm-Attachment.....	42
Figure 33: Teardown Form, p. 1	45
Figure 34: Teardown Form, p. 2	46

LIST OF TABLES

Table 1: Design Metrics Table for Concept #2..... 16
Table 2: Operational Requirements with Identified Needs..... 17
Table 3: Design Requirements with Associated Needs 17
Table 4: Final Parts List..... 43
Table 5: Part Sourcing Instructions..... 43
Table 6: Design Metrics for Final Design..... 47
Table 7: Final Parts List..... 50
Table 8: Bill of Materials..... 50

1. INTRODUCTION

1.1. PROJECT PROBLEM STATEMENT

Design a forearm device that stores cell phones while traveling and provides an easy access apparatus for one handed use on the go. A compression sleeve will be the main feature as it will be the way in which our device will stay on the users arm. An adjustable apparatus that securely holsters the cellphone will be another feature so that our device will be viable for cellphones of varying dimensions. A swivel apparatus that will allow users to select horizontal or vertical viewing of the cellphone while connected to our device. A track system that allows for the movement of the cellphone from different positions on our device.

1.2. LIST OF TEAM MEMBERS

Emily Groth, Jacob Aley, Sinclair “Sin” Hodge

2. BACKGROUND INFORMATION STUDY – CONCEPT OF OPERATIONS

2.1. A SHORT DESIGN BRIEF DESCRIPTION THAT DESCRIBES THE PROBLEM

Cell phones are a continuously evolving technology and an integral part of modern life. Just about everything can be done with cell phones. However, as technology changes and cell phones evolve, there has always been one constant. Cell phones are always hand held. Our problem is to design an integrated system that carries a cell phone on the forearm while traveling and provides an easy access apparatus for cell phone use on the forearm.

2.2. SUMMARY OF RELEVANT BACKGROUND INFORMATION

2.2.1. Closest Competitors

Universal wrist-forearm docking station for mobile electronic devices:

The closest parallel to our design prompt was a universal wrist-forearm docking station and carrier for mobile electronic devices. The device offers adjustability both in regards to rotation of the phone’s angle as well as the linear position in order to accommodate every individual’s preferences. The entire device is then held onto the forearm by use of adjustable straps which are used to provide both comfort and variability for the targeted consumer. By contrast, our project was sleeker, stylish, and streamlined while accomplishing similar tasks while also providing a secure method for protecting the cellphone.

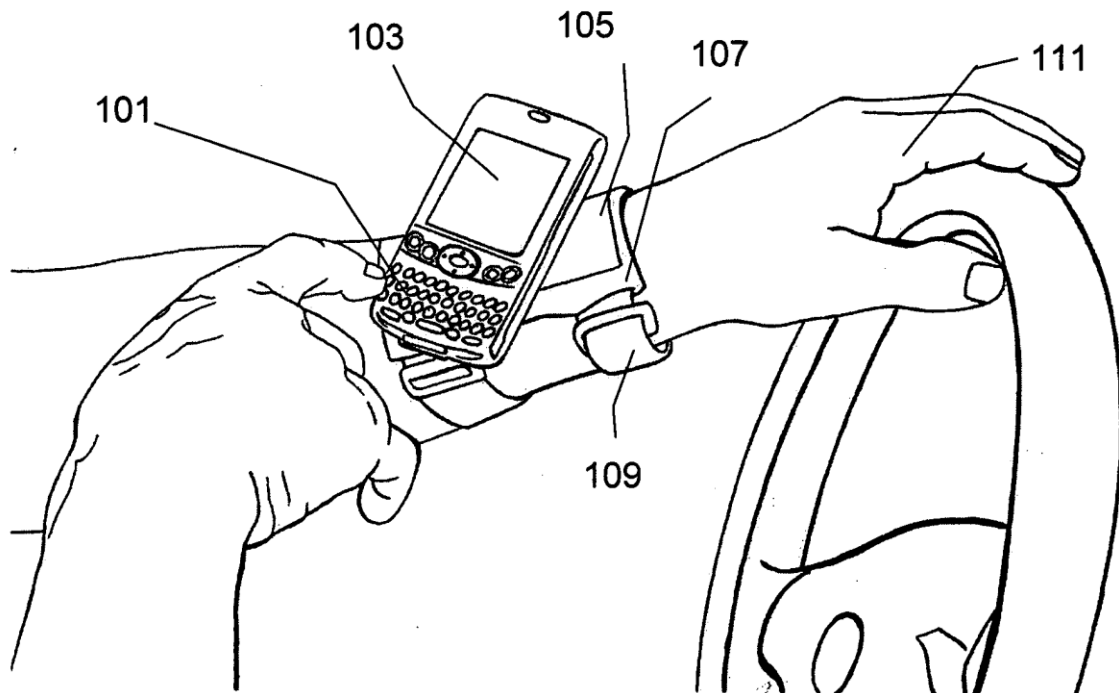

Figure 1: Closest Competitor #1, Patent US 20090321483 A1

The next closest parallel to our design prompt was an apparatus for supporting and operating an electronic device upon a user's forearm. The main use of this device was safeguarding the phone while providing immediate and convenient functional access to the phone. The apparatus was held on the user's forearms by fastening members and the method used to adjust the cellphone was a rotatable supported adjuster. By contrast, our project was sleeker, more stylish, and streamlined while accomplishing similar tasks.

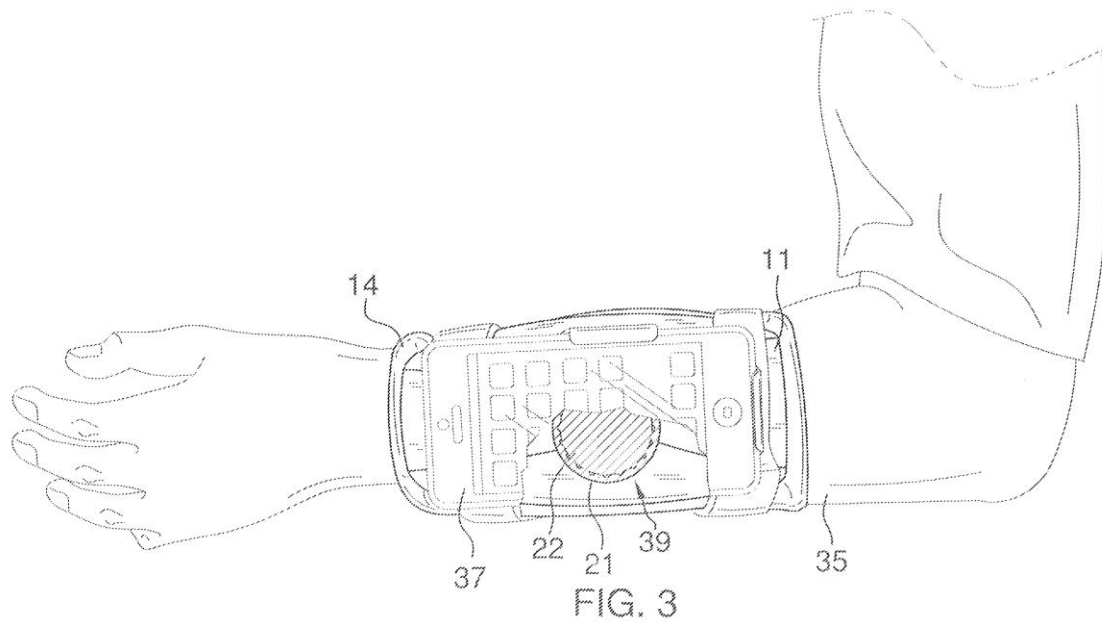

Figure 2: Closest Competitor #2, Patent US 8662362 B1

2.2.2. Significant Risk

There are multitudes of cell phone companies around the world. Due to this fact, there is no standard for the size and shape of the device. There are only basic guidelines in which the companies have to follow, such as the fact that people should be able to hold the phone in their hands in order to use it. This provides the most significant risk to our design in the fact that our apparatus must be able to accommodate varying dimensions of cellphones in order to be feasible. We believe that this is the most significant risk because if the device can only accommodate one brand of phone, or even one particular model, we are significantly limiting our market which then would then limit our possible profits.

2.2.3. Relevant Codes and Standards

MIL-STD-810, Environmental Engineering Considerations and Laboratory Tests is a United States Military Standard that emphasizes equipment's ability to stand up to harsh environments, and various conditions that it will experience throughout its service life. It establishes chamber test methods that replicate the effects of environments on the equipment rather than imitating the environments themselves. The MIL-STD-810 test series are approved for use by all departments and agencies of the United States Department of Defense (DoD). Although prepared specifically for military applications, the standard is often used for commercial products as well. The current document revision (as of 2012) is MIL-STD-810G which was issued on October 31, 2008. The standard's guidance and test methods are intended to: (i) Define environmental stress sequences, durations, and levels of equipment life cycles; (ii) Be used to develop analysis and test criteria tailored to the equipment and its environmental life cycle; (iii) Evaluate equipment's performance

when exposed to a life cycle of environmental stresses; (iv) Identify deficiencies, shortcomings, and defects in equipment design, materials, manufacturing processes, packaging techniques, and maintenance methods; and (v) Demonstrate compliance with contractual requirements.

The MIL-STD-810 is relevant because companies that produce cellphone cases claim that their products are “waterproof, shockproof, etc” when in reality companies do little to no testing due to related expenses. In order to test to see if a product meets military standards, a company would have to hire an independent party to perform the tests, create or rent facilities in which to simulate the environments that the product can be tested in, and then also have plenty of products in which to test. Since there is no commercial agency or organization that certifies compliance, vendors, and manufacturers can technically create the test methods for their specific product's application. Our product will be tested in normal operating conditions, which will include every-day St. Louis weather.

3. CONCEPT DESIGN AND SPECIFICATION – DESIGN REQUIREMENTS

3.1. OPERATIONAL REQUIREMENTS ALLOCATED AND DECOMPOSED TO DESIGN REQUIREMENTS

3.1.1. Customer Interview Questions

Prompt/Question 1 - Would it be convenient to store a cell phone on the interior or exterior of you forearm?

- More convenient to have it on forearm, but nice to have ability to move between interior and exterior.
- Secure on interior, capability to move to the exterior.
- importance: 5

Prompt/Question 2 - Would it be useful to have the phone ejected into your hand for two handed use?

- Yes, especially useful for two handed typing.
- Phone must be able to eject into hand to be used ergonomically.
- importance: 3

Prompt/Question 3 - Do you need to be able to use the phone in portrait and landscape mode on both the interior and exterior of your arm?

- It would be ideal to have the option for both portrait and landscape mode in both the interior and exterior of the forearm.
- Phone needs to be able to rotate on the holster's track.
- importance: 4

3.1.2. List of identified operational and design requirements

Operational Requirements:

Phone Holster with movable case

1. Phone Case

- Female clip compatible with carriage
- Slim/sleek design to not get caught on clothes
- Protects phone from elements

2. Holster Track

- Sleek and discrete
- Carriage doesn't fall out of track
- Shape of cross-section matches with carriage
- Wraps around holster
- Has stops on interior and exterior of forearm

3. Holster Carriage

- Moves smoothly through track
- Compatible with phone case
- Able to move around corners

4. Extending Arm

- Stores inside the "sleeve" of the wrist holder
- Extends out to a ball joint for ease of two-handed use

5. Operating Environment

- Number of user-controlled action
- Number of moving parts
- Case and holster protect phone

Design Requirements:

1. Phone Case

- Female clip compatible with carriage
- No 90 degree edges to get caught on clothes
- 360 degree protection from elements

2. Holster Track

- Entire track system fits within a square inch area
- Wheels designed with same radius as track so as to not allow slippage
- Rectangular track requires rectangular carriage
- Track shaped into a helix with descending radius
- Magnets used as stops at ends of track

3. Holster Carriage

- Axels force fitted with bearings to allow full 360 degree motion
- Non-slip connection with phone case
- Curved design to allow more free motion

4. Extending Arm

- Retractable arm 100% stored in sleeve
- Ball joint implemented to allow for 360 degree of motion

5. Operating Environment

- No movement unless user initiated
- Moving parts reduced to limit sources of problems
- Function unimpeded by environment

3.1.3. Functional allocation and decomposition

3.2. FOUR CONCEPT DRAWINGS

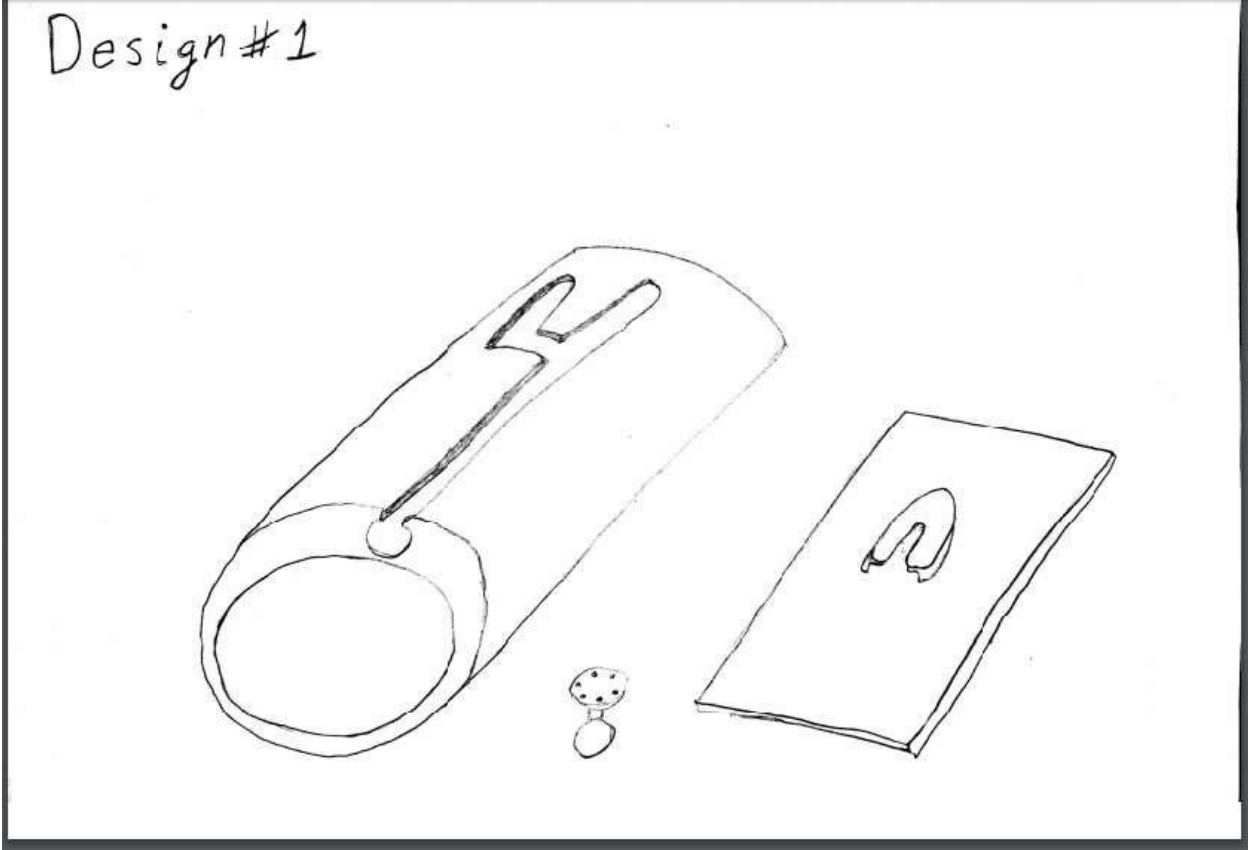

Figure 3: Concept Design #1

Design * 2

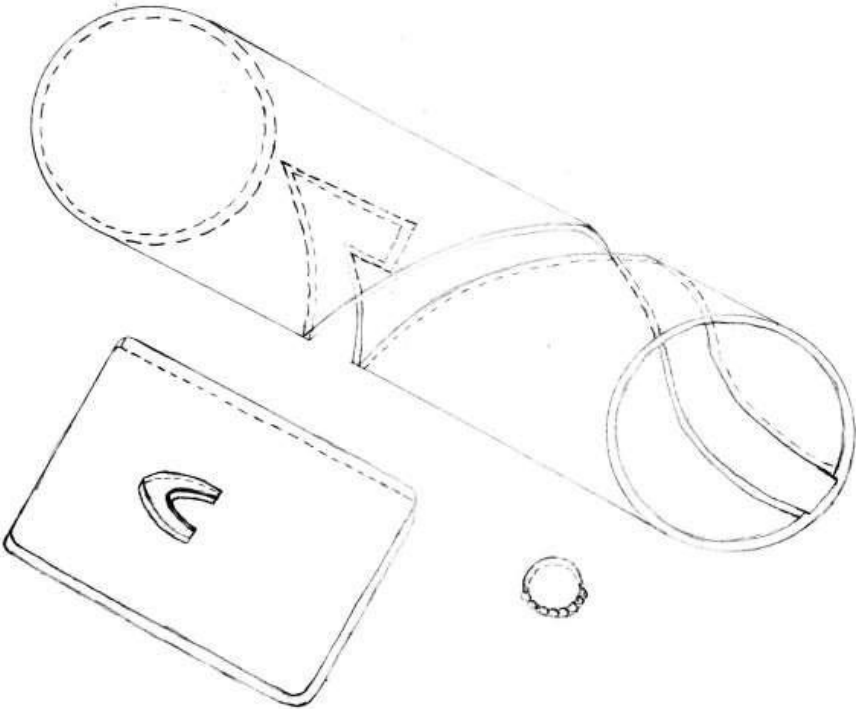

Figure 4: Concept Design #2

Design # 3

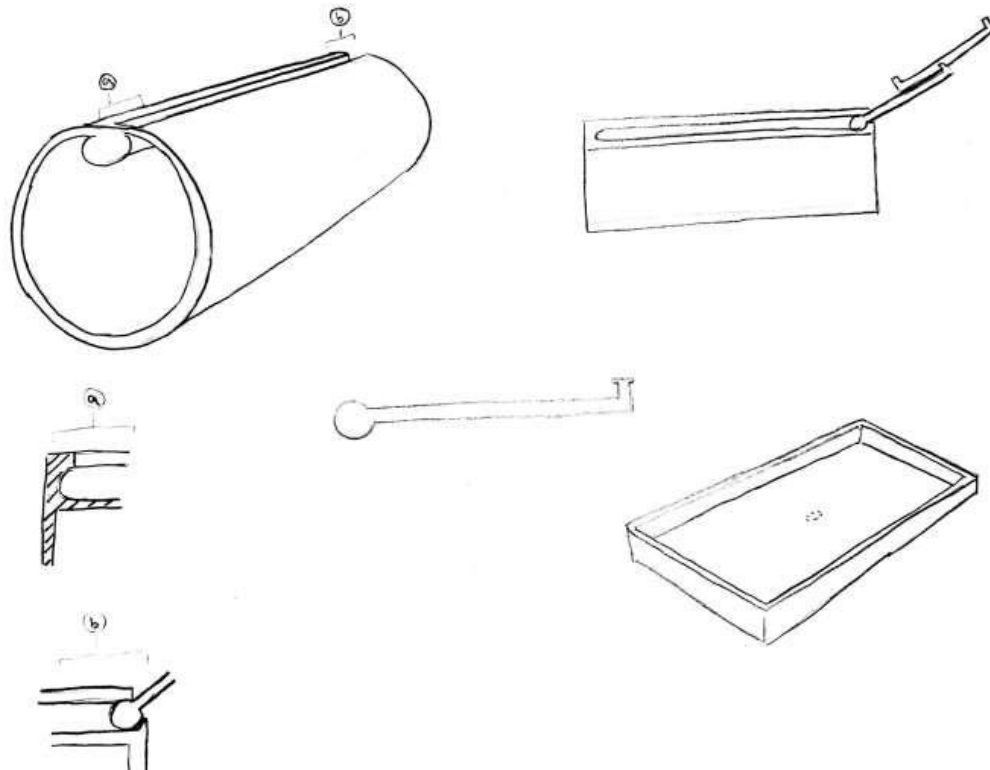

Figure 5: Concept Design #3

Design #4

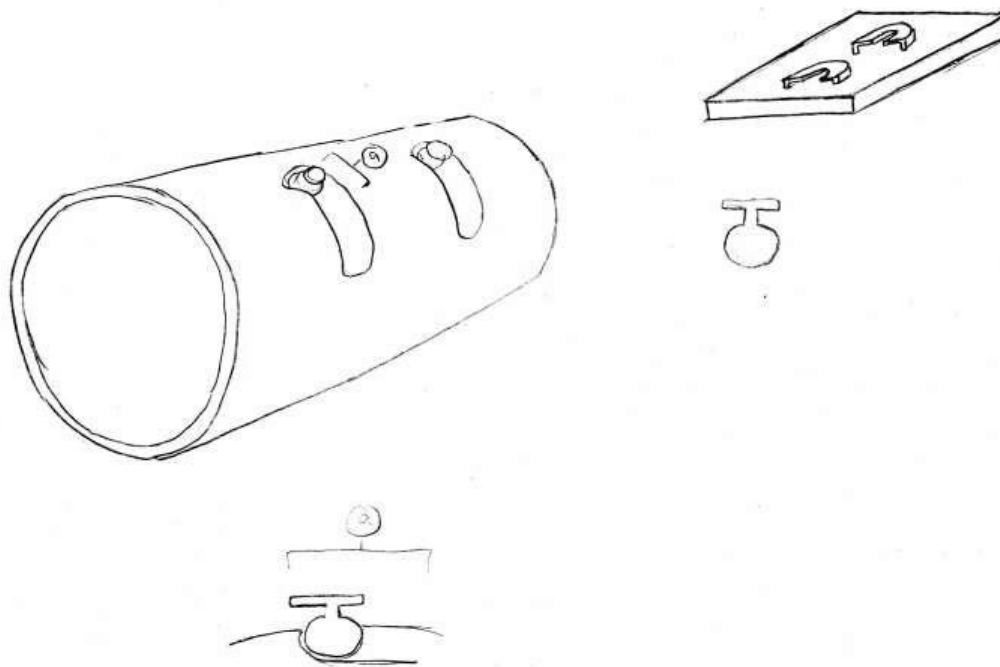

Figure 6: Concept Design #4

3.3. CONCEPT SELECTION PROCESS

3.3.1. Preliminary analysis of each concept's physical feasibility based on design requirements, function allocation, and functional decomposition

Concept 1:

This concept allows for movement of the phone up and down the arm as well as rotation of the phone between portrait and landscape mode as well as a few other options in between. This design allows for the storage of the phone on the inside and outside of the arm near the wrist, and the phone slides into the track near the elbow.

Concept 2:

This concept allows for storage of phone at one end and a quick release of the phone from the apparatus at the other end. It has the same phone rotation mechanic as Concept 1, and the phone slides into the track near the elbow. The phone rests in the hook of the track near the wrist. The helical shape of the track allows for a one armed motion to get phone from storage to be released.

Concept 3:

This concept allows for movement up and down a straight track along the arm. It has the same phone rotation mechanic as Concepts 1 and 2. Phone is attached to an arm piece in the track with a ball that snaps into a ball joint at the end of the track so that the phone can easily be used in your hands and then quickly stored back onto the track in a telescoping motion.

Concept 4:

This concept allows for storage in one place along the forearm. It doesn't let the phone rotate between portrait and landscape. It allows for revolution between the inside and outside of the forearm for ergonomic viewing.

3.3.2. Concept scoring**Table 1: Design Metrics Table for Concept #2**

Metric Number	Associat- ed Needs	Metric	Units	Worst Value	Max Value	Actual Value	Normaliz ed Value
1	1	Length	in.	8	10	9	0.5
2	1	Diameter	in.	2	4	3	0.5
3	3	Weight	g	100	500	350	0.625
4	2,5	Number Of Sharp Edges	Integer	0	5	0	0
5	4	Percent Phones Damaged	Percent	0	100	0	0
						Total	1.625

Table 2: Operational Requirements with Identified Needs

Need Number	Need	Importance
1	Apparatus must fit on forearm (8in-10in long) (2in-3in diameter)	3
2	Apparatus must not catch on clothes (rounded edges)	4
3	Apparatus must not weigh more than a pound	5
4	Apparatus must protect cellphone	5
5	Movement on device must be smooth	4

Table 3: Design Requirements with Associated Needs

Metric Number	Associated Needs	Metric	Units	Worst Value	Max Value
1	1	Length	in.	8	10
2	1	Diameter	in.	2	4
3	3	Weight	g	100	500
4	2,5	Number Of Sharp Edges	Integer	0	5
5	4	Percent Phones Damaged	Percent	0	100

3.3.4. Final summary Statement

WINNER: Concept 2:

Concept 2 had several advantages over the other concepts. We think that the possibility for using just one arm to transport the phone between storage and the release is one of the more important ideals of this project and that the helical design is the best way to accomplish that task. This design also allows for the rotation of the phone between portrait and landscape modes which is another of our main goals for this project and this helical design concept allows for this type of motion as well or better than the other concepts.

We eliminated Concept 4 because of the lack of movement up and down the forearm and the lack of rotation that it offered. We eliminated Concept 3 because of the complexity of the arm and ball joint and because we thought the arm would be a bit cumbersome or get in the way when trying to use the phone in your hands. We eliminated Concept 1 even though it was our initial design because it required two hands to use and we wanted to try to make this project as easy to use as possible.

3.4. PROPOSED PERFORMANCE MEASURES FOR THE DESIGN

- 1) Carriage remains on track.
- 2) Phone and carriage can be held at either end of the track indefinitely.
- 3) Phone can be oriented in multiple ways on the carriage.

3.5. DESIGN CONSTRAINTS

3.5.1. Functional

- Small enough to be worn on a forearm, and must be able to hold the phone at either end of the track, allow for orientation rotation.

3.5.2. Safety

- Must be made of a safe material to use on human skin, must not have any sharp edges.

3.5.3. Quality

- Must be fairly durable so it does not break when dropped.

3.5.4. Manufacturing

- For prototype, limited volume to print in: printers are 6x6x6in so all parts have to be within those dimensions.

3.5.5. Timing

- Printing parts can take hours per part, and there are multiple groups that need to print parts. .

3.5.6. Economic

- We needed to minimize the amount of plastics used, and also stay within our budget of \$331.20.

3.5.7. Ergonomic

- The track must fit comfortably on the forearm, and therefore the helix must have a radius that varies with the forearm.

3.5.8. Ecological

- We must not print or throw away parts in excess, only print what we need, and then use it.

3.5.9. Aesthetic

- The apparatus needs to look clean and neat, and interesting enough so that people will notice it and want to wear it.

3.5.10. Life cycle

- The product must be modular, so that as parts break or need replacing consumers can either print their own parts or pay to have parts printed for them.

3.5.11. Legal

- In order to market this product as living up to the 810G standard we need to perform further testing at appropriate facilities.

4. EMBODIMENT AND FABRICATION PLAN

4.1. EMBODIMENT DRAWING

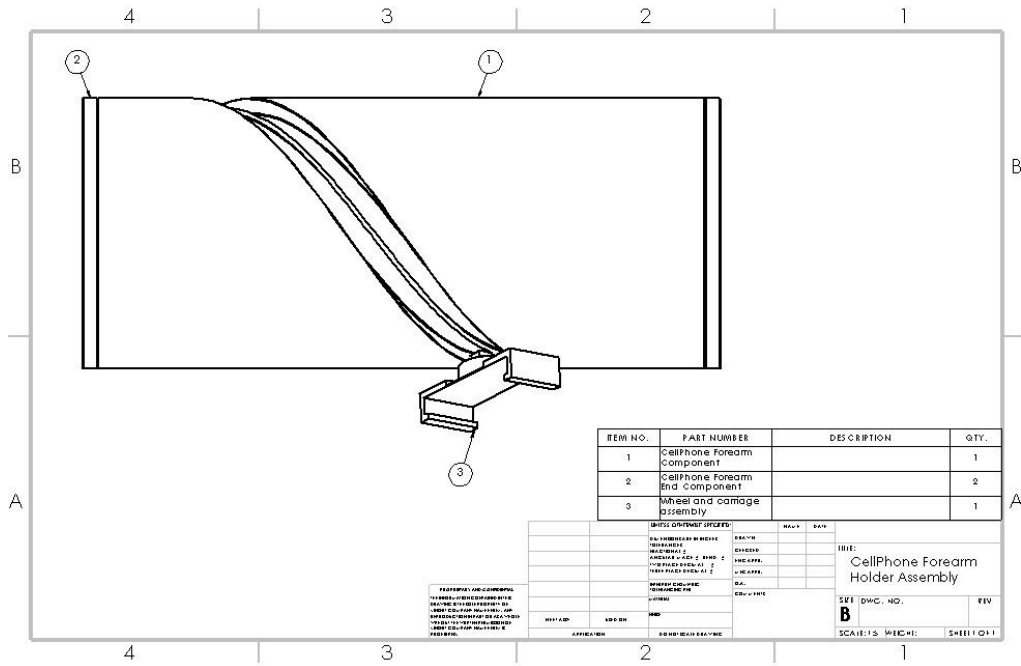

Figure 7: Working Assembly with Bill of Materials

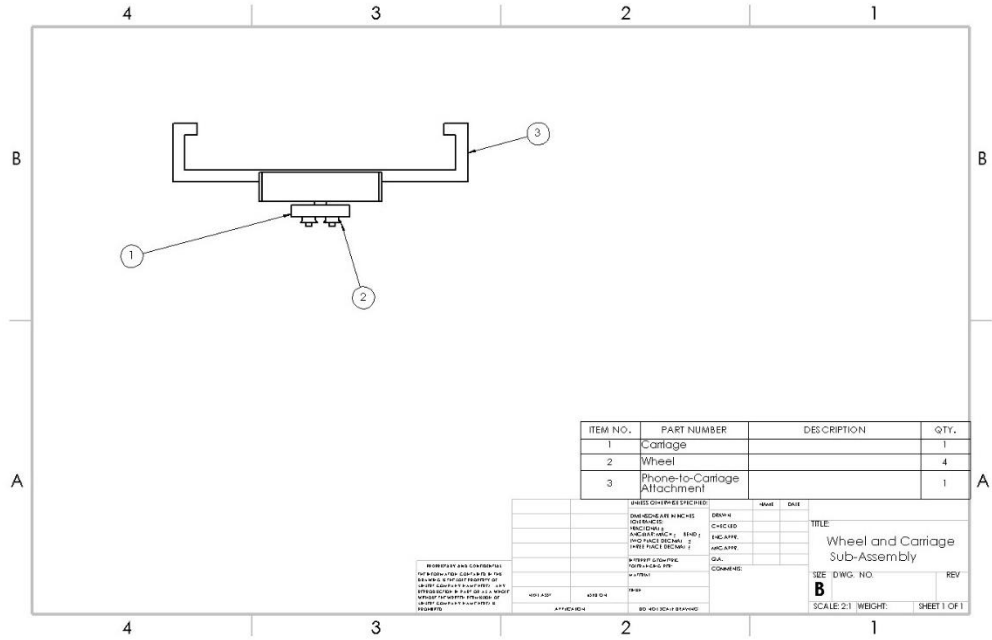

Figure 8: Working Carriage with Bill of Materials

4.2. PARTS LIST

- Cellphone Forearm Component
- Cellphone Forearm End Component
- Phone-to-Carriage Attachment
- Carriage
- Wheel

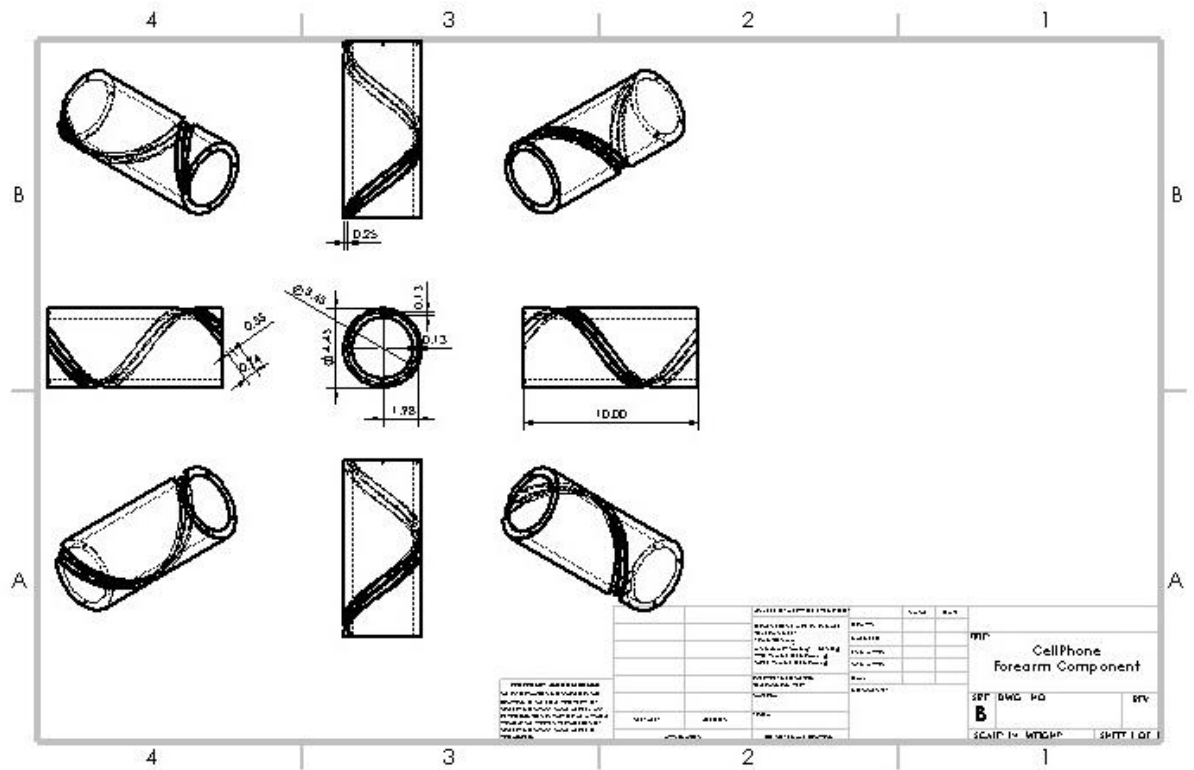

Figure 11: SolidWorks Drawing of Cellphone Forearm Component with Dimensions

4.4. DESCRIPTION OF THE DESIGN RATIONALE FOR THE CHOICE/SIZE/SHAPE OF EACH PART

The carriage must be compatible with the phone case, and with the track, which is embedded in the holster. Furthermore, the carriage must be able to move along the track, which curves around the cylindrical holster. Therefore, the carriage must have a two rotational degree of freedom along the track. It was decided that the best way to achieve this was to have a trough embedded in the cylinder, with a single rail on the bottom. The carriage has two pairs of wheels on the bottom of the carriage: a front and back pair. All the axes of rotation are perpendicular to the carriage. The track runs through each pair of wheels independently, each wheel in both pairs rotate in opposite directions. Because none of the parts will undergo heavy stress, they will all be made out of ABS printed plastic.

4.5. GANTT CHART

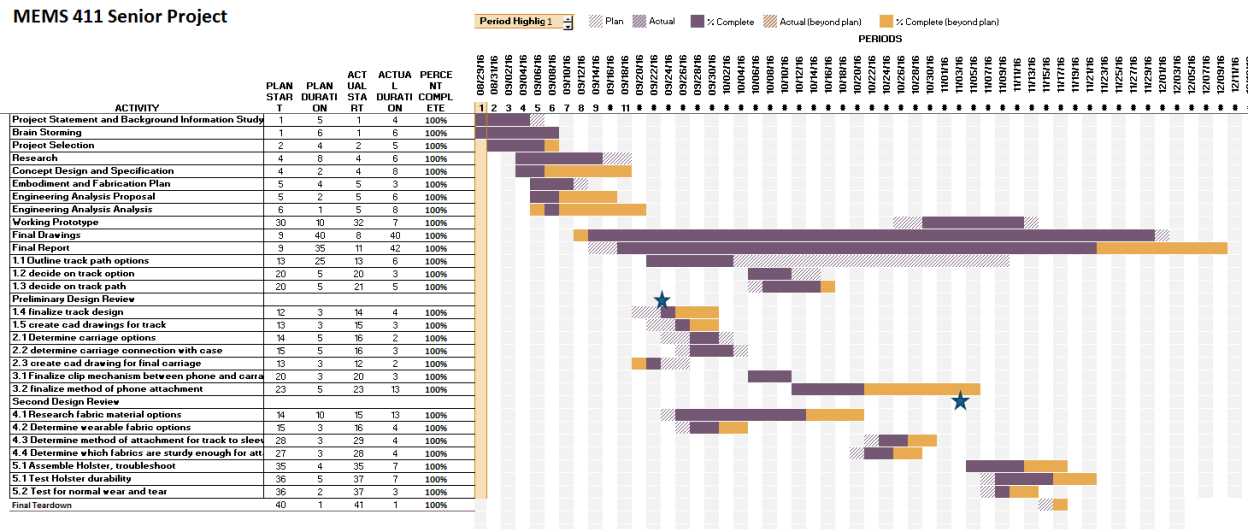

Figure 14: Gantt Chart

5. ENGINEERING ANALYSIS

5.1. ENGINEERING ANALYSIS PROPOSAL

5.2. ENGINEERING ANALYSIS RESULTS

5.2.1. Motivation

At this time, we chose to perform a motion study of the carriage on the track as well as a load and torque analysis of different parts. The motion, load, and torque analyses are critical to understanding the weak points of the track and carriage. More specifically, the motion analysis tells us whether the carriage will move along the track without interference. If there is interference, that is an indication that the design needs to be modified to run smoothly. This is beneficial

to the study at this time because we could model several variations of carriages and test them through the motion simulation rather than waste resources by experimenting with multiple printed parts. The load and torque analyses give an indication of how much force the parts can withstand without warping or breaking. More specifically, the analyses will indicate if there are weak points in our design. If that is the case, then the design would need to be altered to strengthen them. This is beneficial to the study at this time because we can test alterations of parts before printing them, which doesn't waste time or materials.

5.2.2. Summary statement of analysis done

Three static stress tests were performed on the carriage and track using SolidWorks Simulation 2015. A load was applied to the track, a load was applied to the carriage, and a torque was applied to the carriage. Figure 15 shows the results of the load applied to the track. In this particular study, the ends of the track were fixed, gravity was added in the negative z-direction, and a load of 1.12 lbf was applied to the track at varying points. This number was determined by estimating the maximum force a phone would put on the track under standard operating conditions. Figure 16 shows the results of the load applied to the carriage. In this particular study, the sides of the carriage were fixed, gravity was added in the negative z-direction, and a load of .3 lbf was applied to the top of the carriage to simulate a phone bearing down on the carriage. Figure 17 shows the results of the torque applied to the carriage. In this particular study, the top of the carriage was fixed, gravity was added in the negative z-direction, and a torque of .2 lbf was applied to the keyhole to simulate any twisting of the carriage around the track when a substantial force was applied. This number was determined by estimating the maximum torque a phone would put on the carriage under standard operating conditions.

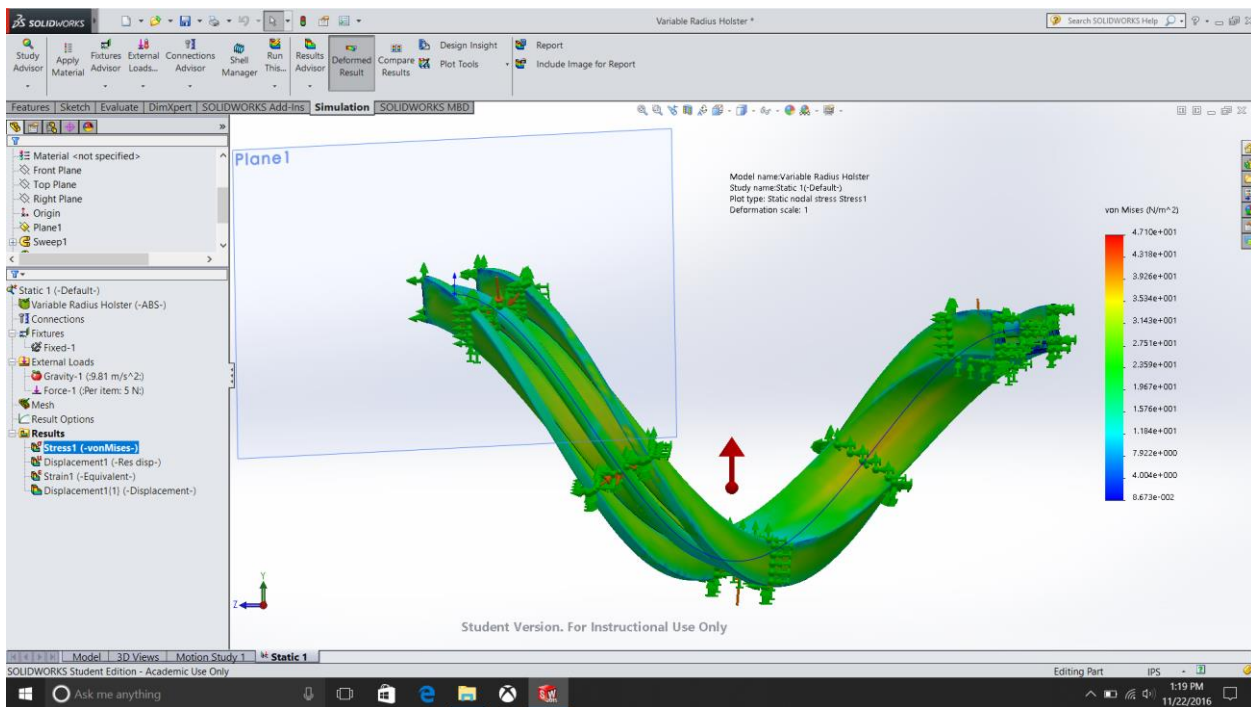

Figure 15: Static Stress Test Performed on Track

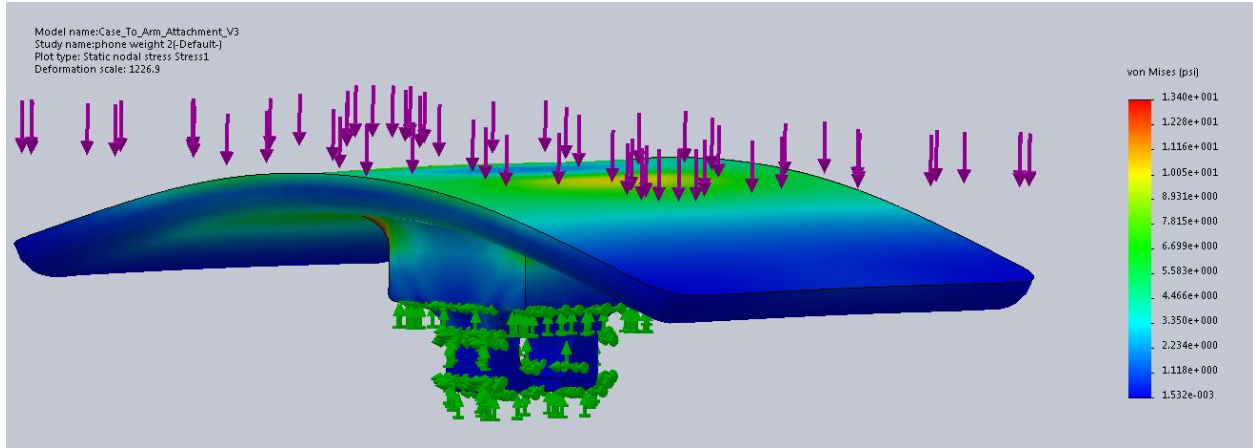

Figure 176: Static Stress Test Performed on Carriage

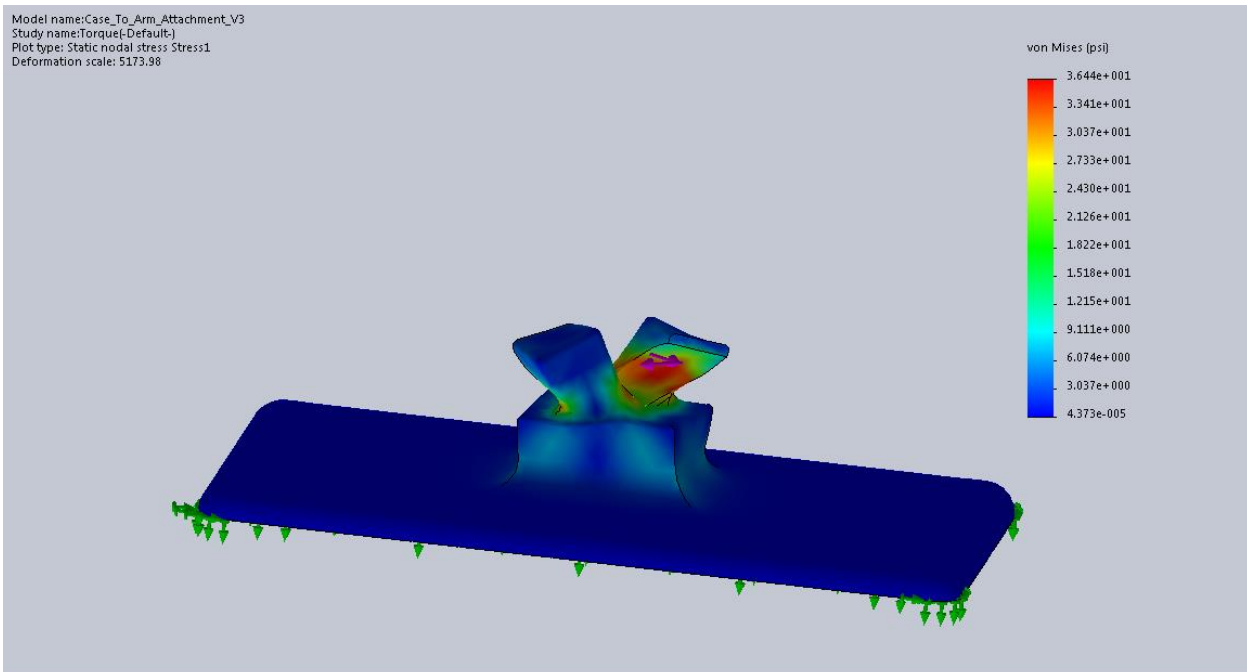

Figure 167: Static Torque Test Performed on Keyhole

5.2.3. Methodology

As previously stated, a motion study and three static stress tests were performed on the components of our device using the Motion Analysis and Simulation add-ons within SolidWorks 2015. The full results of these studies can be seen in Appendix D. The motion study was done by creating an assembly of the track, the carriage, and two end pieces. In order to get the motion study to work we had to copy the sketch of the end of the track and paste it onto both the front and back sides of the keyhole on the carriage. Then from there we were able to use opposing points on the corners of where the rail meets the support in the front and back sketches to create a path mate with the track so that there was constant contact between the carriage and the track. Then we added a tangent mate to the inside of the keyhole and the outside of the track's rail. This allowed us to accurately portray the physical interactions between the track and carriage. Then by applying gravity to the carriage we were able to simulate the carriage moving around the track. SolidWorks Simulations was used to perform the analyses for the three static stress tests. Before beginning the study each part was designated to be ABS plastic so that SolidWorks could accurately calculate the results of the stress tests. Then the forces were applied to simulate real world use. Experimentation for all the studies was only required when it came to applying forces to our models and creating mates between pieces in the assembly. Since all the simulation was done in SolidWorks, no test rig was required.

5.2.4. Results

The results of our analysis are as follows. The motion study was inconclusive due to the limitations of the SolidWorks software. Of the provided mate types in SolidWorks, the majority of them are restricted to be used on flat planes, points, or simple curves. Our device has a helix curve with a varying radius, and the design of the carriage is supposed to limit contact between the keyhole and track. It is therefore impossible to properly simulate the carriage moving around the track. However, as the working prototype demo proved, our current design of the carriage, which has one keyhole, effectively travels along the track with minimal force needed to overcome friction. The three static tests indicate that the components will not break or warp under standard operating conditions. We define standard operating conditions to be an average sized phone attached to the carriage, undergoing normal gravity and pressure, and with all the components undamaged. The results from the prototype demo and SolidWorks Simulation make sense and support moving forward with our current design concept.

5.2.5. Significance

The results of the simulations and prototype demo show that the track is structurally sound to leave as originally designed. However, the carriage was redesigned to utilize a keyhole instead of a wheel and axle system to bear the load. The other initial dimensions for the track and carriage did not need to be altered. The simulations prove that the parts can easily withstand any reasonable loads applied during use. All of the components were 3D printed using ABS plastic, which didn't change.

5.2.6. Summary of code and standards and their influence

Figure 18 shows the design of the track that has been used since the beginning. The picture also demonstrates the need to 3D print the parts: the dimensions of the part are such that machining a piece like this would be near impossible with the tools and abilities available. The

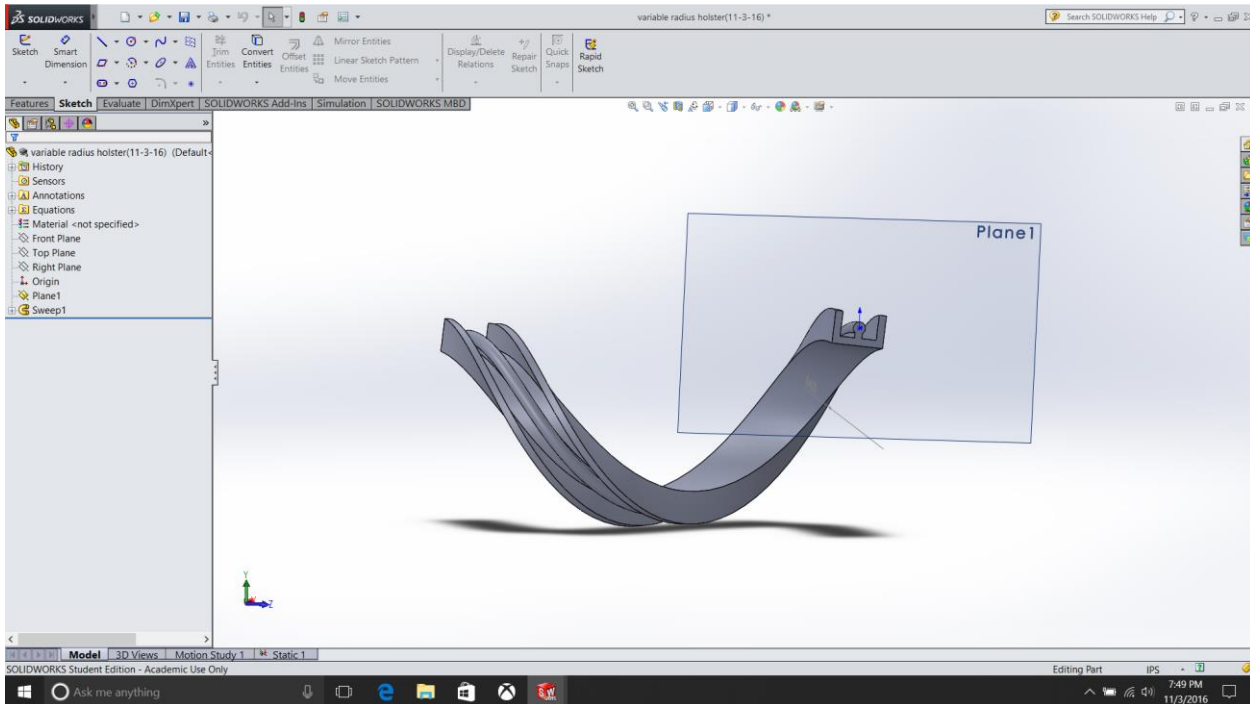

Figure 18: Current Track Design

standard that we tried to design to was the MIL-STD-810G. This is the military standard for toughness and drop strength. We were severely limited by our choice of materials and manufacturing method for this prototype. However, in future editions of the prototype, as it get closer to manufacturing, more research and development will be necessary to ensure that the product meets this standard.

5.2.7. Motion Study Link

<https://www.youtube.com/watch?v=IMcIy7DTYdo&feature=youtu.be>

5.3. RISK ASSESSMENT

5.3.1. Risk Identification

There is risk associated with printing parts: 3D printing is imperfect, and print jobs often fail. This could put us off of our very tight schedule. Also, there is a chance that the part will print incorrectly, resulting in a defect. This will also put us off schedule. The plastic used in 3D printing (ABS) could fail while the prototype is being tested. This would force us to redesign or reprint our prototype. In our initial designs, when we were using parts that we had to order, there was a risk that the parts would come late, or that the wrong

parts would arrive. This would hurt our budget, and put us off schedule. Finally, there is a risk that the prototype will not be fit everyone. This is out of scope for the prototype design, but would have to be addressed before bringing it to mass production.

5.3.2. Risk Impact or Consequence Assessment

In our initial engineering analysis stage, we identified the risks in section 5.2.1 and took steps to mitigate them. We printed our parts ahead of schedule whenever possible. We designed our parts to be as strong as possible so that they would not break while being tested. We ordered the parts early, from McMaster-Carr, so that we could be confident that they would arrive on time. We designed the prototype to fit the members of our group so that it would be appropriate for testing.

5.3.3. Risk Prioritization

1. Printing error
2. Plastic fail
3. Prototype fit
4. Parts ordering

We prioritized mitigating the risk of printing error, because that was the most likely risk to occur. This was also the most likely to put us off schedule and the risk we had the most control over so we deemed it most important to mitigate. We also attempted to mitigate the plastic strength, but then learned that we had no choice over the materials used in our printing process so we made it a low priority risk. We also deemed parts ordering to be a lower priority risk because we changed our design to not need the parts we had dered. The universal prototype fitting was also a low priority risk because it was out of the scope of our project.

6. WORKING PROTOTYPE

6.1. A PRELIMINARY DEMONSTRATION OF THE WORKING PROTOTYPE

6.2. A FINAL DEMONSTRATION OF THE WORKING PROTOTYPE

6.3. AT LEAST TWO DIGITAL PHOTOGRAPHS SHOWING THE PROTOTYPE



Figure 19: Final Prototype



Figure 20: Final Prototype

- 6.4. A SHORT VIDEO CLIP LINK SHOWING PROTOTYPE PERFORMING
<https://www.youtube.com/watch?v=yFs82UTdPvg&feature=youtu.be>

6.5. AT LEAST 4 ADDITIONAL DIGITAL PHOTOGRAPHS AND THEIR EXPLANATIONS

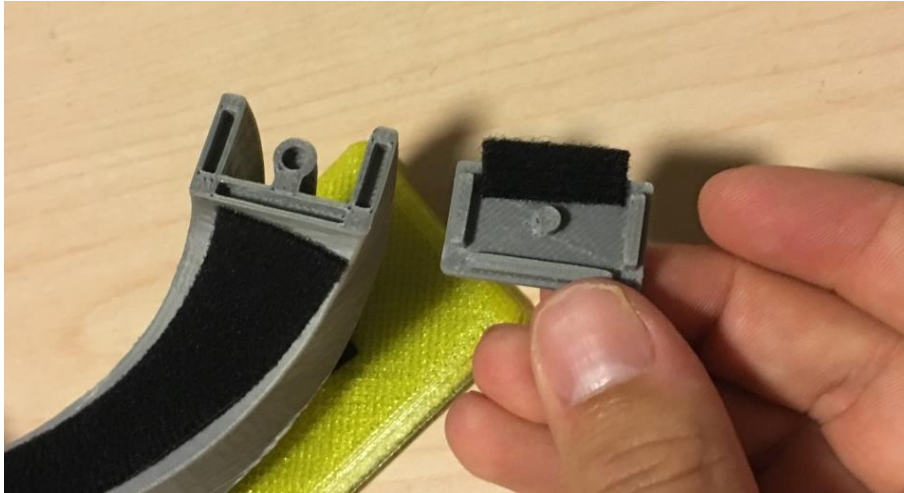

Figure 21: Track and End-Caps

Here you can see how the end-caps fit into the track securely in order to prevent the carriage from sliding off of the track. Both parts were 3D printed to specific dimensions so that they would fit snugly and securely.

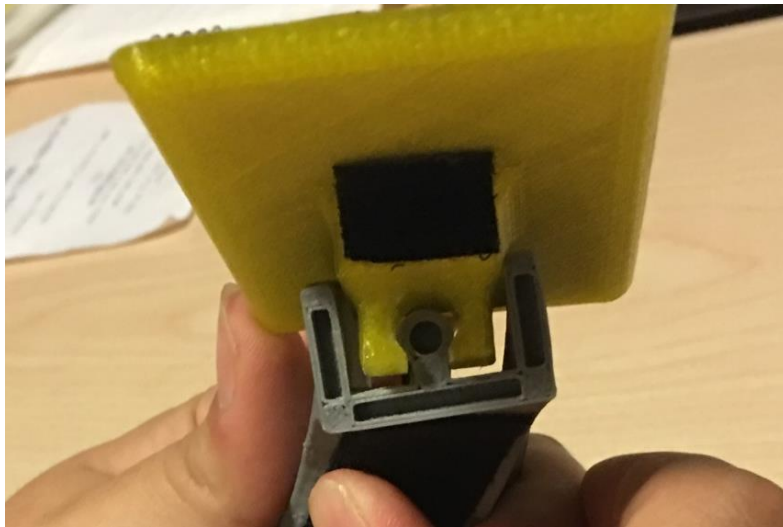

Figure 22: Track and Carriage

Here you can see how the carriage fits onto the track so that it can slide all the way from one end to the other. Both parts were 3D printed to specific dimensions so that the carriage would slide along the track without coming off.



Figure 23: Carriage and Phone Orientation

Here you can see several options for phone orientation when mounted onto the carriage. The top face of the carriage is covered with velcro hooks and the back of the phone has a section of velcro loops so that the phone will be securely connected to the carriage no matter the orientation.



Figure 24: Velcro Holding Carriage at End-Cap

Here you can see the carriage being held at one end of the track for storage when travelling or the phone is otherwise not needed. There are velcro loops on the end-cap and velcro hooks on

the underside of the carriage so that the carriage will easily stay at the end-cap for an indefinite amount of time.

7. DESIGN DOCUMENTATION

7.1. FINAL DRAWINGS AND DOCUMENTATION

7.1.1. ENGINEERING DRAWINGS

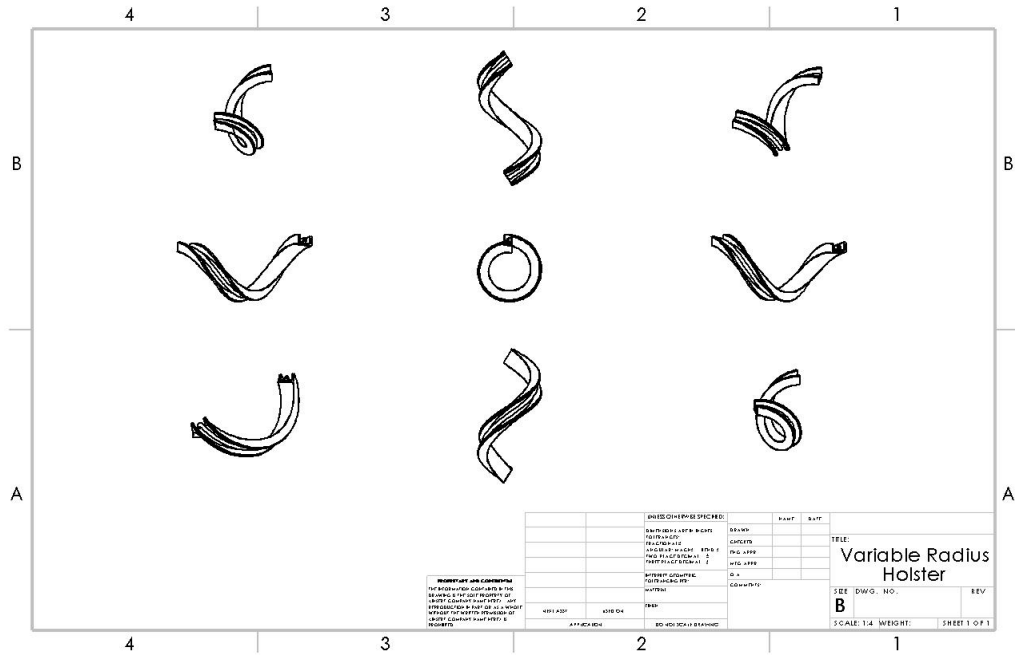

Figure 25: SolidWorks Drawing of Variable Radius Holster

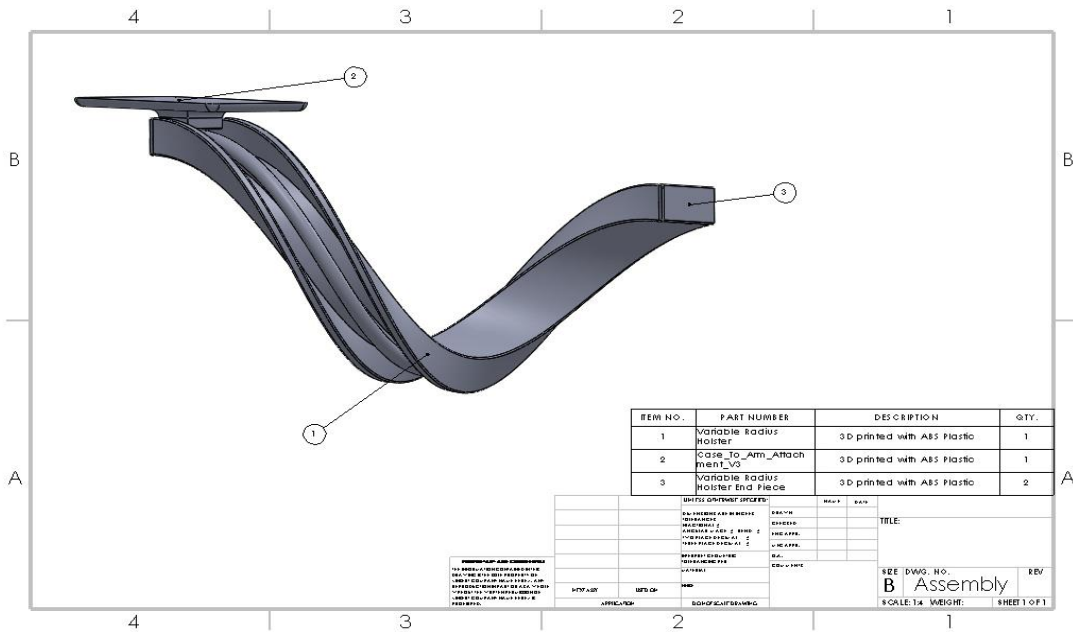

Figure 28: SolidWorks drawing of Final Assembly with Bill of Materials

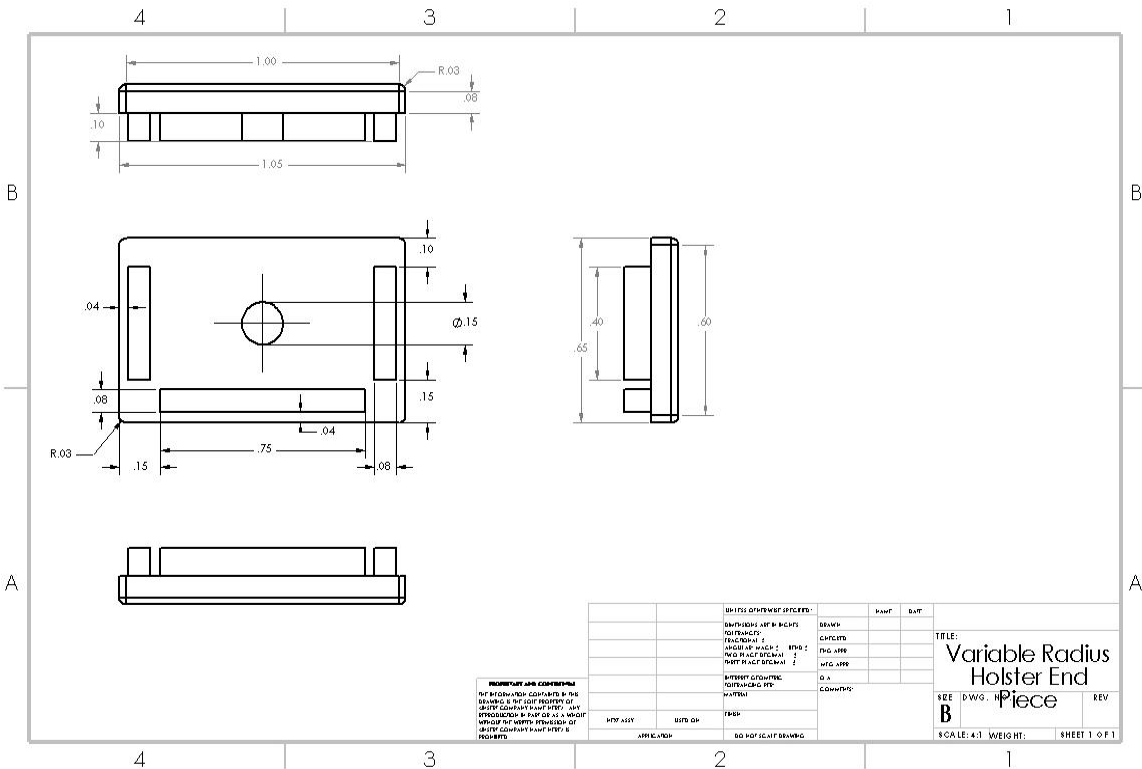

Figure 27: SolidWorks Drawing of Variable Radius Holster End Piece with Dimensions

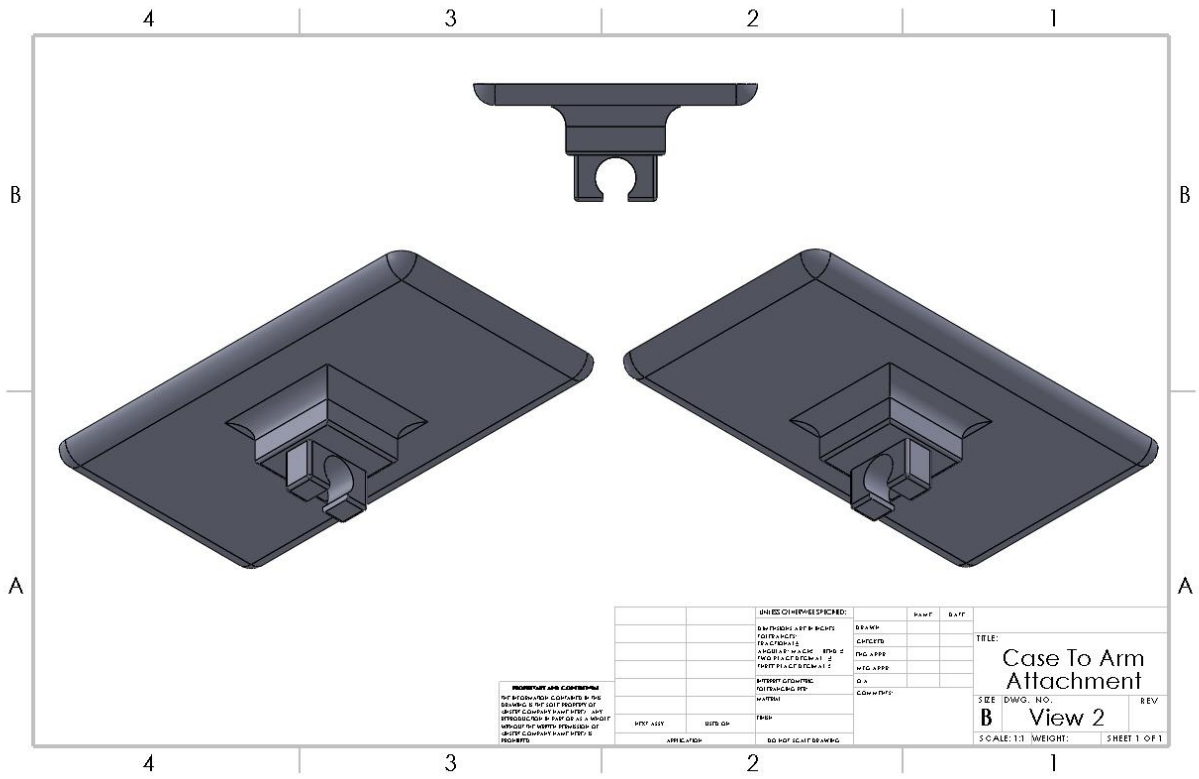

Figure 32: Alternate SolidWorks Drawing of Case-To-Arm-Attachment

7.1.2. Sourcing instructions

Table 4: Final Parts List

# Parts Needed:	Part Name:	Source:	Catalog Number	Part Use:
1	Variable Radius Holster	3D Printed	N/A	Main body of part & track
1	Carriage	3D Printed	N/A	Holds phone to track
2	Variable Radius Holster End Pieces	3D Printed	N/A	Keeps carriage from falling off track
1	Velcro	Michael's	N/A	Attach assembly to forearm, attach phone to carriage, hold carriage at end caps

Table 5: Part Sourcing Instructions

Part Name:	Source:	Catalogue #:	Price Each:	Total Price:	Sourcing Instructions:
Variable Radius Holster	3D Printed	N/A	Free	Free	SolidWorks 2015 used to model parts, 3D printer used to print parts with ABS plastic
Carriage	3D Printed	N/A	Free	Free	SolidWorks 2015 used to model parts, 3D printer used to print parts with ABS plastic

Variable Radius Holster End Pieces	3D Printed	N/A	Free	Free	SolidWorks 2015 used to model parts, 3D printer used to print parts with ABS plastic
------------------------------------	------------	-----	------	------	--

7.2. FINAL PRESENTATION

7.2.1. EXTERNAL REVIEW BOARD PRESENTATION

A live presentation demonstrating the working prototype occurred in front of an external review board on December 5, 2016.

7.2.2. LINK TO EXTERNAL REVIEW BOARD PRESENTATION VIDEO

https://www.youtube.com/watch?v=aFixu38xf_Y

7.3. TEARDOWN

TEARDOWN TASKS AGREEMENT

Group F
PROJECT: Cell Phone Holder NAMES: Jacob Alay INSTRUCTOR: Malost/Jakiela
Emily Groth EG
Sim Hodge & Mudge

The following teardown/cleanup tasks will be performed:

Cleaned up work area (3D printer)
Taking hardware home

Figure 33: Teardown Form, p. 1

Instructor comments on completion of teardown/cleanup tasks:

Instructor signature: Mary Malast; Print instructor name: MARY MALAST
Date: 12/8/16

(Group members should initial near their name above.)

Figure 34: Teardown Form, p. 2

8. DISCUSSION

8.1. USING THE FINAL PROTOTYPE PRODUCED TO OBTAIN VALUES FOR METRICS, EVALUATE THE QUANTIFIED NEEDS EQUATIONS FOR THE DESIGN. HOW WELL WERE THE NEEDS MET? DISCUSS THE RESULT.

When comparing the design metrics in Table 6 to Table 1, it is clear that there have been some changes between the preliminary concept design and the final design. The main change was that a new metric was added to more accurately capture the fact that the final design is a helix with a variable radius. In other words, the radii of the two ends of the final design are not the same. Specifically, one end of the final design has a radius of 4 in. while the other end of the final design has a radius of 3 in. As we expected, since there are more metrics in Table 6 than in Table 1, the final value is larger. However, if we take each final number and normalize them, 1.625 from Table 1 and 2.115 from Table 6, then we get 0.325 and 0.3525 respectively. These values show that all of the needs were met to within 65% of a perfect world. The metric that threw off our final normalized value was the number of sharp edges in the final design. Due to the specific manufacturing method that we chose, 3D printing, even after filleting every edge on the model, sharp edges were still present. The most relevant fix, in regards to our project, would be to sand down these edges until the edges weren't sharp anymore. Another possible fix could be to enlarge the radius of the filleting in the model and reprint the affected parts.

Table 6: Design Metrics for Final Design

Metric Number	Associated Needs	Metric	Units	Worst Value	Max Value	Actual Value	Normalized Value
1	1	Length	in.	8	10	8.75	0.375
2	1	Inner Diameter	in.	2.5	3.5	3	0.5
3	1	Outer Diameter	in.	3.5	4.5	4	0.5
4	3	Weight	g	100	500	246	0.365
5	2,5	Number Of Sharp Edges	Integer	0	17	6	0.375
6	4	Percent Phones Damaged	Percent	0	100	0	0
						Total	2.115

8.2. DISCUSS ANY SIGNIFICANT PARTS SOURCING ISSUES? DID IT MAKE SENSE TO SCROUNGE PARTS? DID ANY VENDOR HAVE AN UNREASONABLY LONG PART DELIVERY TIME? WHAT WOULD BE YOUR RECOMMENDATIONS FOR FUTURE PROJECTS?

In the end, all of our parts were 3D printed in-house. This was essential: the parts were too unique to be found in stores, and were too complicated to be machined. The printing generally went very smoothly. Even though the printers were often busy with other groups, there were many printers and Prof. Woodhams was very accommodating of all of our printing needs. We only had one real issue with printing: when printing the track (with the helix pointing upwards), the printer did not want to build the necessary support for the upper half. This was worked around by exchanging a few lines of code to force the printer to build the necessary support. This was fixed quickly, and did not end up hindering our progress. We would recommend 3D printing, within reason, for future projects: the printers have the

While we ended up only using 3D printed parts, we did order an axle and 8 small bearings from McMaster-Carr for an earlier design. These parts arrived within three days. We would recommend using McMaster-Carr for future projects.

8.3. DISCUSS THE OVERALL EXPERIENCE:

8.3.1. Was the project more or less difficult than you had expected?

The project was more difficult than we had expected. Particularly, we had many difficulties using SolidWorks; many aspects of the design were far beyond the scope of what we had studied in previous classes, and anything we had experience with. Our first design roadblock was with the track: it was difficult to figure out how to keep the cross-section of the track perpendicular to the helix. Our issues with the design aspect of SolidWorks compounded when it came to the Motion Simulation aspect of the project. It took much more time than expected to figure out how to mate the carriage with the track, as the keyhole of the carriage has a flat interior surface, and the track is curved.

8.3.2. Does your final project result align with the project description?

Our final project aligns very closely with the project description: we ended up building a holster that wraps around the forearm. The phone can move up and down the track, staying indefinitely at either end as we initially stipulated. The only part of the project description that we did not align with was the ability of the phone to rotate while connected to the carriage: it has to be taken off the carriage and reattached. However, this is not a significant failing, as the rotation ability was never a core aspect of our design description.

8.3.3. Did your team function well as a group?

Our team functioned fairly well as a group. There were times when we disagreed on the goals of the project, but we were always able to have productive discussions about how to move forward.

8.3.4. Were your team member's skills complementary?

Yes; Sinclair enjoyed working on the CAD models and simulations, and was willing to spend a lot of time working out the kinks in the projects. Emily was adept at predicting problem spots in the design, and also was able to solve some of the sticky SolidWorks issues. Jacob was particularly good at creatively coming up with solutions to problem spots in the design, streamlining the workflow, and taking the initiative with the report.

8.3.5. Did your team share the workload equally?

It was sometimes difficult to work collaboratively on SolidWorks files, but regardless the team shared the workload as equally as possible.

8.3.6. Was any needed skill missing from the group?

As previously stated, we ran into SolidWorks issues that stretched the bounds of our skills. We had to learn skills that were not required of us in our CAD class. While this skill was initially missing, we learned it along with way.

8.3.7. Did you have to consult with your customer during the process, or did you work to the original design brief?

We consulted with the customer at the beginning of the design process, and created the original design brief from that. We were able to work off of the design brief for the vast majority of the process, but consulted the customer again during preliminary design, to affirm the importance of several design parameters.

8.3.8. Did the design brief (as provided by the customer) seem to change during the process?

The design brief did not change during the process.

8.3.9. Has the project enhanced your design skills?

Yes, we feel like we have a better understanding of how designs change with respect to briefs and requirements. We've learned how to determine when a design change is needed, and when it is inappropriate.

8.3.10. Would you now feel more comfortable accepting a design project assignment at a job?

We would feel much more comfortable accepting a design project assignment- especially with the new skills in design revision. We also feel that after struggling through the road-blocks, we have significantly more skills with SolidWorks.

8.3.11. Are there projects that you would attempt now that you would not attempt before?

We do not have any projects in mind that we would attempt now but would not have before. However, we would like to mention that if we came across a project that involved creating CAD models and 3D printing, we would definitely be more likely to attempt them now than we would have before.

9. APPENDIX A - PARTS LIST

Table 7: Final Parts List

# Parts Needed:	Part Name:	Part Use:
1	Variable Radius Holster	Main body of part & track
1	Carriage	Holds phone to track
2	Variable Radius Holster End Pieces	Keeps carriage from falling off track
1	Velcro	Attach assembly to forearm, attach phone to carriage, hold carriage at end caps

10. APPENDIX B - BILL OF MATERIALS

Table 8: Bill of Materials

# Parts Needed:	Part Name:	Price Each:	Total Price:
1	Variable Radius Holster	Free	Free
1	Carriage	Free	Free
2	Variable Radius Holster End Pieces	Free	Free
1	Velcro		

11. APPENDIX C - CAD MODELS AND STRESS TEST REPORTS

<https://drive.google.com/drive/folders/0B0UfI8rIRasJY0pmUXZJb05kQTA?usp=sharing>

12. ANNOTATED BIBLIOGRAPHY

- 1) *Environmental Engineering Considerations and Laboratory Tests*, MIL-STD-810G, 31 October 2008.

This military standard describes codes for durability, drop height, water-resistance, etc. While it was written for military gear, it can be altered for commercial enterprises.