

Washington University in St. Louis

Washington University Open Scholarship

Mechanical Engineering Design Project Class

Mechanical Engineering & Materials Science

Fall 12-9-2017

Group F Drink Mixer - MIXoTRON

Rebecca Danielle Stone

Washington University in St. Louis

Christina Bell

Washington University in St. Louis

Devon Roell

Washington University in St. Louis

Follow this and additional works at: <https://openscholarship.wustl.edu/mems411>



Part of the [Mechanical Engineering Commons](#)

Recommended Citation

Stone, Rebecca Danielle; Bell, Christina; and Roell, Devon, "Group F Drink Mixer - MIXoTRON" (2017).

Mechanical Engineering Design Project Class. 78.

<https://openscholarship.wustl.edu/mems411/78>

This Final Report is brought to you for free and open access by the Mechanical Engineering & Materials Science at Washington University Open Scholarship. It has been accepted for inclusion in Mechanical Engineering Design Project Class by an authorized administrator of Washington University Open Scholarship. For more information, please contact digital@wumail.wustl.edu.



Washington University in St. Louis

SCHOOL OF ENGINEERING & APPLIED SCIENCE

Executive Summary

For our Mechanical Engineering Senior Design project, we designed and built the MIXoTRON, an automatic bartending device. This device takes in a drink order from a user and automatically mixes the drink by dispensing 1.5oz of each ingredient into the cup. This is done through movement in both the linear and rotational z axis. The cup rests on a turntable that moves to orient the cup under a single bottle. The bottles are then driven vertically downward by a lead screw to press against the cup and dispense the liquid. Ideally, the MIXoTRON will be able to mix drinks in about the same time as, or faster than, a human bartender would.

The current prototype has been fully assembled, but has not yet been programmed to take in an order or move autonomously. The current programming utilizes four keypad buttons that activates four basic functions: turning the turntable counter clockwise and clockwise, and moving the carriage holding the bottles up and down the lead screw. There is also one button that stops all motion. If more time was available, we would program the device to autonomously make a drink per user input.

MEMS 411: Senior Design Project

Drink Mixer

Christina Bell

Devon Roell

R. Dani Stone

TABLE OF CONTENTS

List of Figures	5
List of Tables	6
1 Introduction and Background Information	7
1.1 Initial Project Description	7
1.2 Existing Products	7
1.3 Relevant Patents	9
1.4 Codes & Standards	11
1.5 Project Scope	11
10.1 Project Planning	12
10.2 Realistic Constraints	12
10.2.1 Functional	12
10.2.2 Safety	13
10.2.3 Quality	13
10.2.4 Manufacturing	13
10.2.5 Timing	13
10.2.6 Economic	13
10.2.7 Ergonomic	13
10.2.8 Ecological	14
10.2.9 Aesthetic	14
10.2.10 Life Cycle	14
10.2.11 Legal	14
10.3 Revised Project Description	14
11 Customer Needs & Product Specifications	15
11.1 Customer Interviews	15
11.2 Interpreted Customer Needs	17
11.3 Target Specifications	18
12 Concept Generation	18
12.1 Functional Decomposition	18
12.2 Morphological Chart	20

12.3	Concept #1 – “Indrunkinator”	21
12.4	Concept #2 – “Drink-O-Matic”	22
12.5	Concept #3 – “Squeeze-o-Matic”	23
12.6	Concept #4 – “BloodyMary-go-Round”	24
12.7	Concept #5 – “Wheel of Booze”	25
12.8	Concept #6 – “MIXoTRON”	26
13	Concept Selection	27
13.1	Concept Scoring Matrix	27
13.2	Explanation of Winning Concept Scores	30
13.3	Explanation of Second-Place Concept Scores	30
13.4	Explanation of Third-Place Concept Scores	30
13.5	Summary of Evaluation Results	31
14	Embodiment & Fabrication plan	31
14.1	Isometric Drawing with Bill of Materials	31
14.2	Exploded View	34
14.3	Additional Views	35
15	Engineering Analysis	37
15.1	Engineering Analysis Results	37
15.1.1	Motivation	37
15.1.2	Summary Statement of the Analysis	38
15.1.3	Methodology	38
15.1.4	Results	43
15.1.5	Significance	43
15.2	Product Risk Assessment	44
15.2.1	Risk Identification	44
15.2.2	Risk Heat Map	45
15.2.3	Risk Prioritization	45
16	Design Documentation	46
16.1	Performance Goals	46
16.2	Working Prototype Demonstration	46

16.2.1	Performance Evaluation	46
16.2.2	Working Prototype – Video Link	48
16.2.3	Working Prototype – Additional Photos	48
17	Discussion	52
17.1	Design for Manufacturing – Part Redesign for Injection Molding	52
17.1.1	Explanation of Design Changes	52
17.2	Design for Usability – Effect of Impairments on Usability	52
17.2.1	Vision	52
17.2.2	Hearing	53
17.2.3	Physical	53
17.2.4	Language	53
7.2	Overall Experience	53
7.2.1	Does your final project result align with the initial project description?	53
7.2.2	Was the project more or less difficult than you had expected?	53
7.2.3	In what ways do you wish your final prototype would have performed better?	53
7.2.4	your group missing any critical information when you evaluated concepts?	53
7.2.5	Were there additional engineering analyses that could have helped guide your design?	54
7.2.6	How did you identify your most relevant codes and standards and how they influence revision of the design?	54
7.2.7	What ethical considerations (from the Engineering Ethics and Design for Environment seminar) are relevant to your device? How could these considerations be addressed?	54
7.2.8	On which part(s) of the design process should your group have spent more time? Which parts required less time?	54
7.2.9	Was there a task on your Gantt chart that was much harder than expected? Were there any that were much easier?	54
7.2.10	Was there a component of your prototype that was significantly easier or harder to make/assemble than you expected?	54
7.2.11	If your budget were increased to 10x its original amount, would your approach have changed? If so, in what specific ways?	55
7.2.12	If you were able to take the course again with the same project and group, what would you have done differently the second time around?	55
7.2.13	Were your team member’s skills complementary?	55

7.2.14	Was any needed skill missing from the group?	55
7.2.15	Has the project enhanced your design skills?	55
7.2.16	Would you now feel more comfortable accepting a design project assignment at a job?	55
7.2.17	Are there projects you would attempt now that you would not have attempted before?	55
8	Appendix A - Parts List	56
9	Appendix B - CAD Models	57
10	Annotated Bibliography	66

LIST OF FIGURES

Figure 1: The Inebriator	7
Figure 2: The MakrShakr	8
Figure 3: Patent Number: US20110113967 A1	9
Figure 4: Patent Number: US4590975 A	10
Figure 5: Gantt Chart	12
Figure 6: Function Tree	19
Figure 7: Morphological Chart	20
Figure 8: Concept Drawing 1 – The Indrunkinator.....	21
Figure 9: Concept Drawing 2 – Drink-O-Matic.....	22
Figure 10: Concept Drawing 3 – Squeeze-o-Matic.....	23
Figure 11: Concept Drawing 4 – BloodyMary-Go- Round	24
Figure 12: Concept Drawing 5 – Wheel of Booze	25
Figure 13: Concept Drawing 6 – MIXoTRON	26
Figure 14: Isometric Drawing.....	32
Figure 15: Bill of Materials.....	32
Figure 16: Isometric View	33
Figure 17: Exploded View	34
Figure 18: Front View.....	35
Figure 19: Side View	36
Figure 20: Top View.....	37
Figure 21: Finding the torque of the lead screw motor.....	39
Figure 22: Finding the load on the lead screw	39
Figure 23: Finding the torque required to drive the lead screw	40
Figure 24: Calculating the gear ratio required from the motor to the lead screw for different factors of safety.....	40
Figure 25: Finding the required motor speed.....	41
Figure 26: Finding the critical speed of the lead screw	42
Figure 27: Determining the actual speed of the motor.....	42
Figure 28: Torque speed curve of the lead screw motor	43
Figure 29: Risk identification template.....	44
Figure 30: Risk Assessment Heat Map	45
Figure 31: Total Current Draw and Battery Life Calculations [2].....	47
Figure 32: Total Number of Recipes Calculation	47
Figure 33: Inner Circuitry of the MIXoTRON	48
Figure 34: The MIXoTRON in Operation	49
Figure 35: Disassembling the MIXoTRON.....	50
Figure 36: Volumetric Valve Dispensing Liquid.....	51
Figure 37: Before and after comparison of one of the lead screw gears chosen for draft analysis.....	52
Figure 38: Parts List.....	56

Figure 39: CAD Drawing of Lazy Susan.....	57
Figure 40: CAD Drawing of Wooden Base.....	58
Figure 41: Lead Screw Gear, Modified from McMaster Part 6832K6600.....	59
Figure 42: McMaster Gear Modified for Lead Screw.....	60
Figure 43: Motor Gear, Modified from McMaster Part 6832K6590.....	61
Figure 44: McMaster Gear Modified for Motor Gear.....	62
Figure 45: CAD Drawing of Threaded Rod, Received from McMaster.....	63
Figure 46: CAD Drawing of Turntable, Received from McMaster.....	64
Figure 47: CAD Drawing of Thrust Bearing, Received from McMaster.....	65

LIST OF TABLES

Table 1: Customer Interview 1 - Breanna Gillette - Bartender at Glory Days Grill – 9/13/2017.....	15
Table 2: Customer Interview 1 - Cathryn Boggs - Bartender at Captain Billy's Crab Shack – 9/17/2017.....	16
Table 3: Interpreted Customer Needs.....	17
Table 4: Target Specifications.....	18
Table 5: Concept Scoring Matrix (1 of 3).....	27
Table 6: Concept Scoring Matrix (2 of 3).....	28
Table 7: Concept Scoring Matrix (3 of 3).....	29

1 INTRODUCTION AND BACKGROUND INFORMATION

1.1 INITIAL PROJECT DESCRIPTION

Bars are a great setting for friends to meet and drink however there aren't many special features that set one bar apart from the rest. What you won't find in any bar today is robotic bartender able to make any drink to order.

In addition, there are many ways to make certain drinks, allowing for much variation. Automating the cocktail making process eliminates the variation in alcohol levels and in ingredients used. In addition, it guarantees that your drink will not have anything in it that the customer does not explicitly see. Giving the customer options of existing drinks and customizable features will ensure a smooth and enjoyable drinking experience for everyone.

1.2 EXISTING PRODUCTS

1. The Inebriator

<https://www.theinebriator.com/>



Figure 1: The Inebriator

This device is a very close representation of what we are envisioning for the project. It uses a car on a linear track and several nozzles to systematically fill the glasses with the desired liquids. When it

completes its run and is finished filling the glass, the stand on which the glass sits on flashes a bluish color to indicate it is finished.

2. MakrShakr

<http://www.makrshakr.com/>

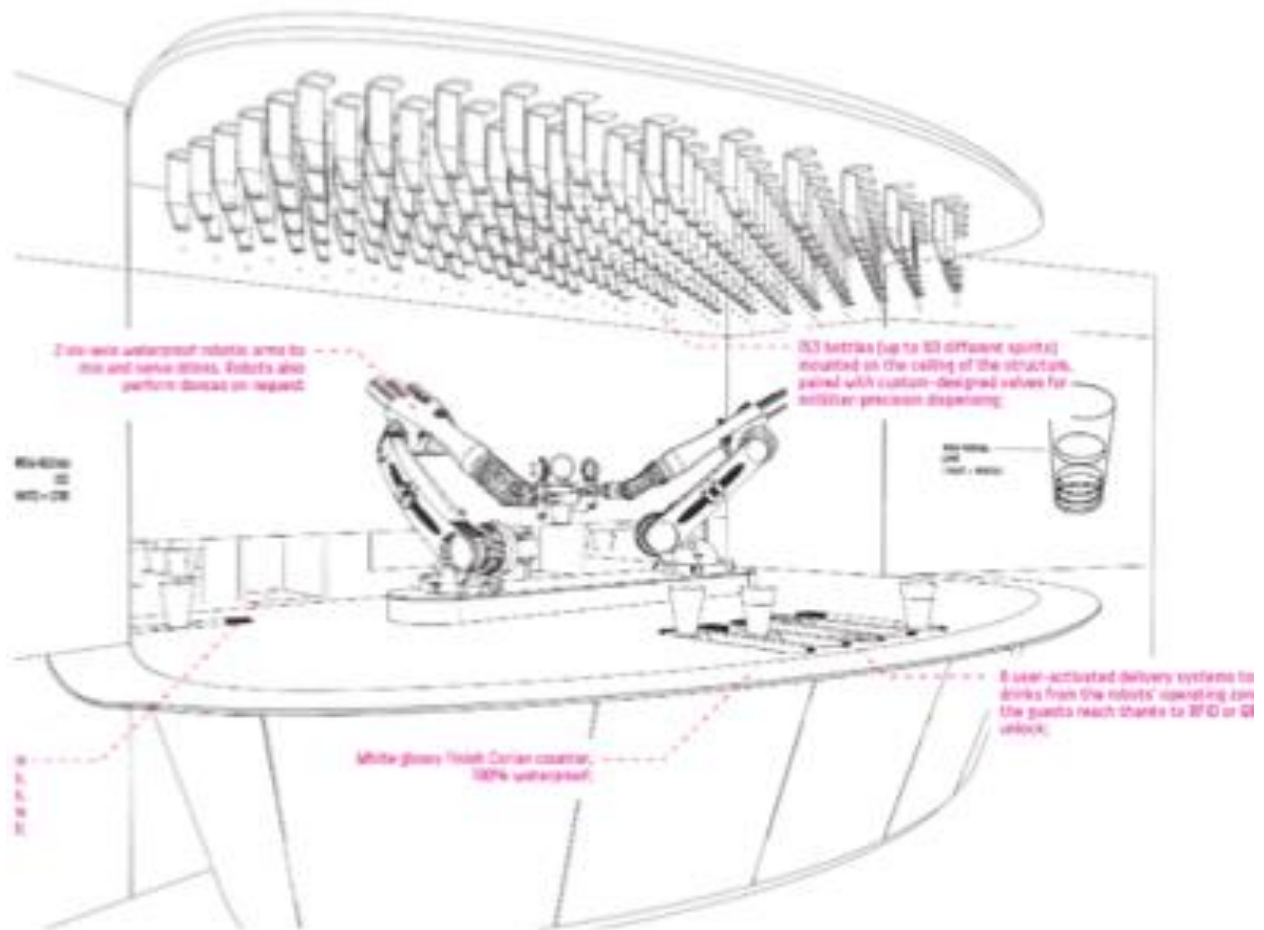

Figure 2: The MakrShakr

The MakrShakr is a “robotic bar system” that makes drinks in a shaker and pours the drink into a glass. It consists of 2 robotic arms and is a sleek and modern looking bar. From the website, it seems that there are only a few of these in the world and they go to different places for different “installations” almost as if it is an art piece; it is a full experience just to go to see a MakrShakr in action. The physical machine is of interest, but more intriguing is the app that they have created. They allow the guest to download an app and request drinks from the app. The user can customize their own drink, or they can choose from

existing drinks. Users can also communicate with other patrons and select the drinks others make. In addition, users can rate and comment the drinks of others, giving suggestions on drink recipes.

1.3 RELEVANT PATENTS

Patent Number: US20110113967 A1

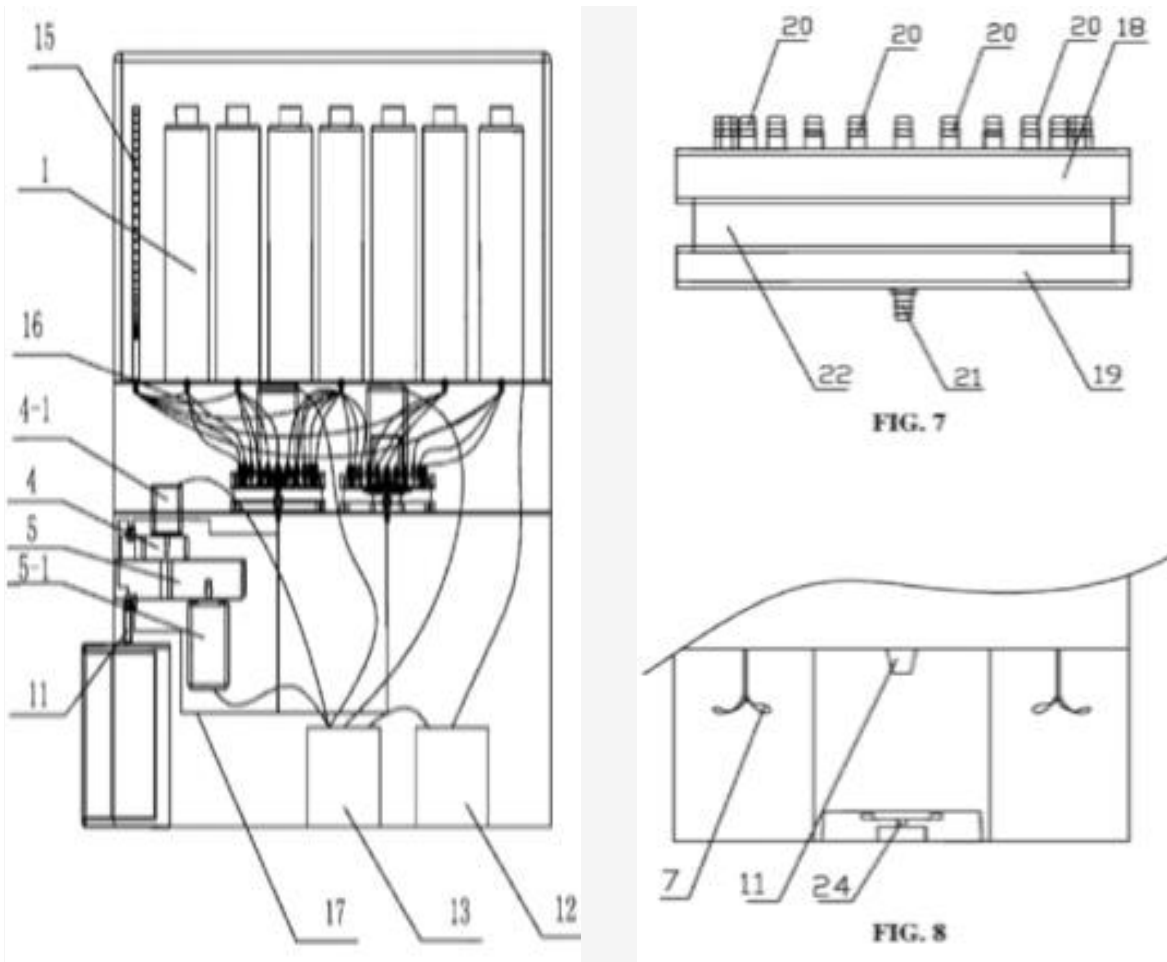

Figure 3: Patent Number: US20110113967 A1

This patent is for an “Automatic Cocktail Maker”. It mostly involves the pumping system in the valves, but it also covers the frame and the switching system.

Patent Number: US4590975 A

Figure 4: Patent Number: US4590975 A

This patent is from 1986 and mostly deals with the conveyor belt of the drink machine. It patents the idea that the glasses move through the machine picking up ice and a drink along the way.

1.4 CODES & STANDARDS

Code: *NSF/ANSI 18 - 2016, Manual Food and Beverage Dispensing Equipment.*

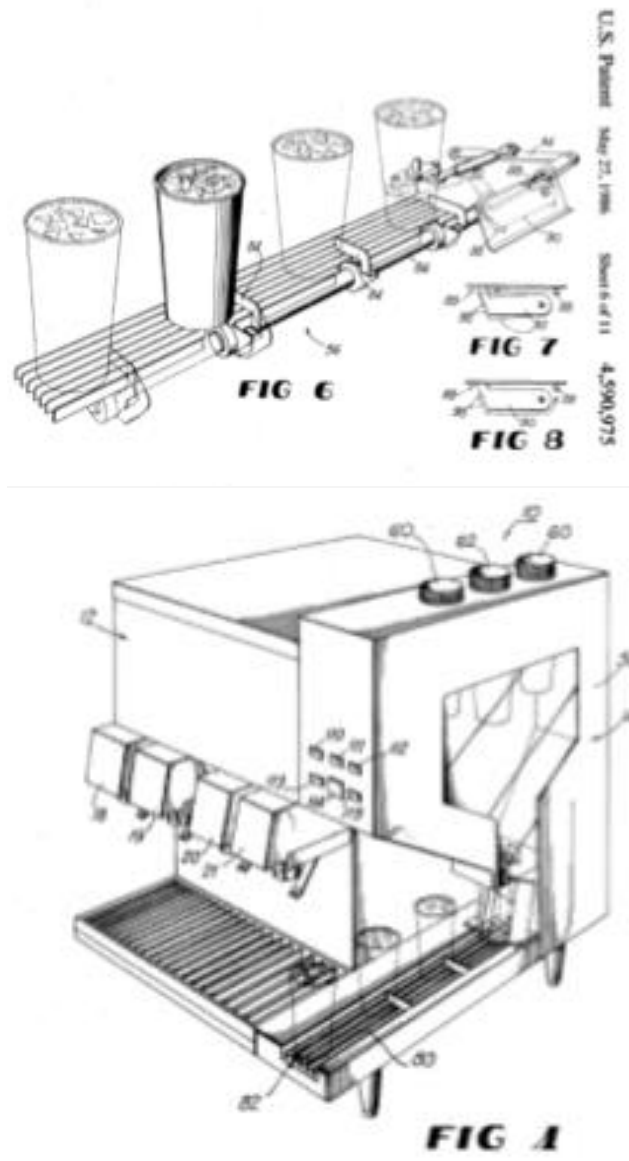
1.5 PROJECT SCOPE

- 1 Our project is the Automatic Drink Maker. The purpose of this machine is to dispense and mix made-to-order alcoholic beverages.
- 2 We will be making this product for sports bars, tech bars and other sorts of novelty bars where the machine will complement the aesthetic.
- 3 This machine will assist the bartender in increasing their productivity. It will also regulate the amount of alcohol in each drink, ensuring that the bar owners are not over- or under-pouring their drinks. This will both reduce wasted alcohol while maintaining the drink quality. Customers may feel more comfortable with an automated drink maker to avoid human error or malevolent intent. It could also bring in more patrons who are interested in a novel drinking experience.
- 4 This machine will, given an order (input), dispense a well-mixed alcoholic beverage in under 30 seconds.
- 5 The project will get people their drinks in a timely and entertaining manner. It will mix the drink. The machine will also communicate drink status while also trivially conversing with the patron.
- 6 Our drink mixer will only make individually sized drinks. It will not require identification in order to operate the machine.
- 7 The project must
 - a. Accurately follow and execute a recipe
 - b. Thoroughly mix a drink
 - c. Effectively communicate drink status
 - d. Accurately pour liquids into one glass
 - e. Accurately log amount of alcohol in reserves
- 8 Assumptions
 - a. Our customer wouldn't want to stir their own drink
 - b. Customers will enjoy a uniform recipe for drinks
 - c. Shaking is necessary at all
- 9 Constraints
 - a. Time- 1 semester
 - b. Cost- unknown
 - c. Scheduling- between class schedule and work
- 10 Deliverables
 - a. User interface with drink options
 - b. Mixing component
 - c. A piping system to deliver drinks to reservoir

10.1 PROJECT PLANNING

We developed a Gantt chart to plan this project. The Gantt chart includes dates for all class assignments and deadlines, as well as allotted time for research, part ordering, building, and troubleshooting.

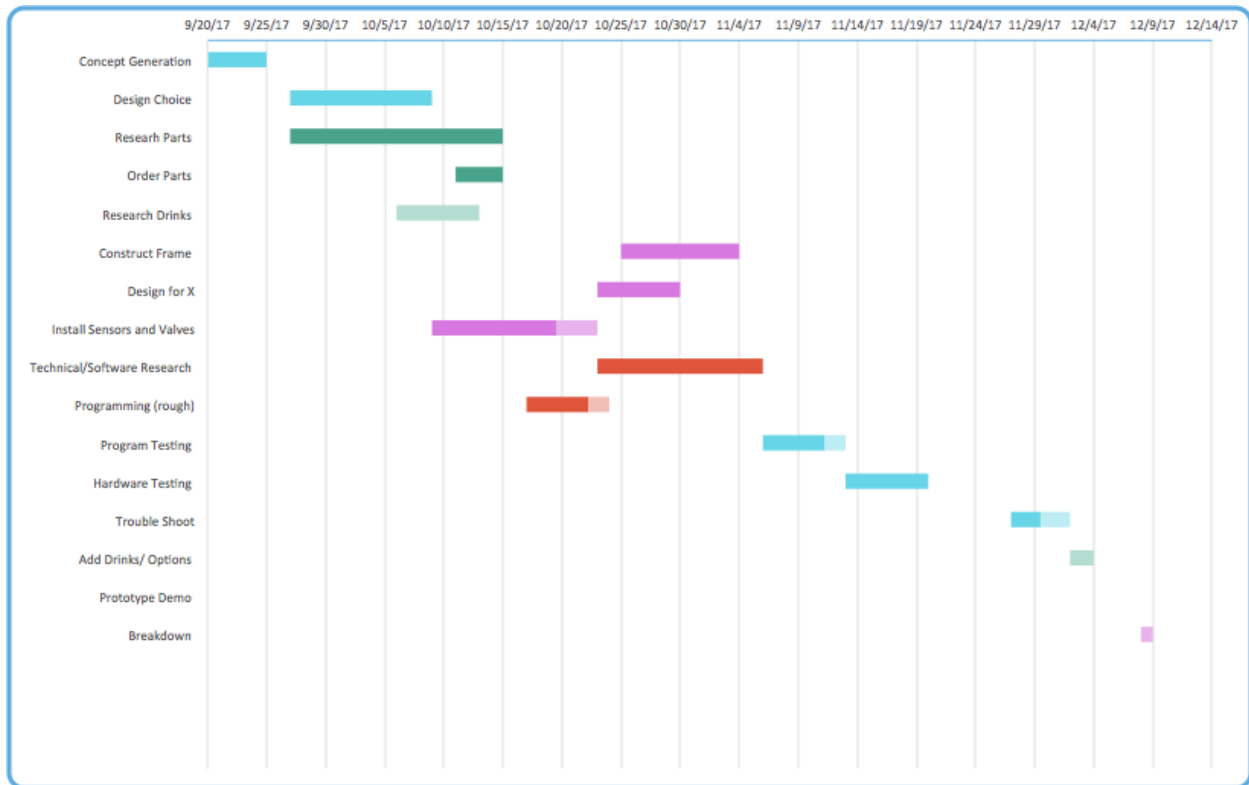

Figure 5: Gantt Chart

10.2 REALISTIC CONSTRAINTS

Below, we went through several aspects of design and in order to determine the constraints that led us to our final and most successful prototype.

10.2.1 Functional

Geometrically, we have decided to contain our project to the size of a soda machine that you would find in a restaurant. We figured that there will be at least that much space available on a bar if desired. We had to ensure that our project was made of material which could be constructed to support about a 20 lb load. We found that scrap wood fastened with brackets would be sufficient. By constricting the number of moving parts in our project to two, the threaded rod and the wheel pushing the Lazy Susan, we reduced the project to its simplest form.

10.2.2 Safety

In terms of safety, we are constrained to the beverage dispensing safety standard depicted in Section 1.4 above. We have adhered to this standard by making the parts of the system that are in contact with the beverages are easily removable and easily cleanable. We will ensure that all personnel operating the machine are well trained in disassembling and cleaning the machine. In addition, we have considered implementing an ID scanner to ensure that patrons are of age to be consuming alcoholic beverages.

10.2.3 Quality

As mentioned above, we are currently adhering to the safety and quality regulations. A main point of our project is to ensure quality and consistency of the cocktails produced by the machine. The volumetric valves confirm that each time the liquid is dispensed, it dispenses 1.5 oz.

10.2.4 Manufacturing

For manufacturing, we were limited to building materials available within university storage. To minimize upfront costs, we used scavenged wood for the frame and base as well as plexiglass for the rotation surface. Several design choices were made based on what materials were already on hand. We were also limited to the equipment in the machine shops on campus. While some of these machines are quite precise (such as the milling machine), we also had to make use of less-precise machines, such as the bandsaw.

10.2.5 Timing

Our time spent on this project was, of course, constrained to one 14-week semester. We met for recitation 2 hours every week to work on our project with an additional 2-10 hours per week outside of class time.

10.2.6 Economic

As mentioned in manufacturing, we decided to use wood as the material for the majority of our components. Campus had a ready supply of plywood and cutting equipment which allowed the entirety of our budget to go to specialty components and electronics. We were also provided a budget of \$161.28. This money was budgeted to cover the cost of the volumetric valves and bottle holder, various electronic equipment, and other materials that we could not salvage from university storage.

10.2.7 Ergonomic

Ergonomic constraints have to do with the interface between the user and the device. In our case, we have two different kinds of users: the customer and the bartender. First, the customer uses the device to make a custom drink of their choosing. This means that the interface we choose must be easy to read and easy to use to select the drink. The bartender, then must make sure that the machine is clean and in working condition. This means that the device must be easy to clean (i.e. at a decent height so as not to cause back pain when cleaning or maintaining it) and have very low basic maintenance requirements.

10.2.8 Ecological

There are not many ecological constraints for our project. The only power source used is a battery pack and in the final design, this will move to just be plugged into the wall. We could remind all bar owners to make sure to recycle the bottles used.

10.2.9 Aesthetic

The aesthetic appeal of our project was another main focus for us. We think that displaying the bottles upside down in the rack makes the machine look cool and intriguing. The circular motion of the Lazy Susan is also a fun aspect to the machine. In future iterations, our design would take a sleeker shape.

10.2.10 Life Cycle

The main realistic life cycle constraints that applied to our project was that the materials we chose to build this project must be able to be salvaged for future projects. This meant designing a project that was fairly simple to completely assemble and disassemble without destroying any parts. Most materials that were used for this project were those that were salvaged from university storage. As long as we take good care of the materials we gather, we should be able to return everything to storage.

10.2.11 Legal

As long as we are adhering to the beverage dispensing standard and our patrons are drinking responsibly, we should have no legal issues. If an ID scanner is implemented, we could consider limiting the number of drinks per patron to make sure we will not overserve patrons.

10.3 REVISED PROJECT DESCRIPTION

Bars are a great setting for friends to meet and drink however there aren't many special features that set one bar apart from the rest. What you won't find in any bar today is robotic bartender able to make any drink to order.

In addition, there are many ways to make certain drinks, allowing for much variation. Automating the cocktail making process eliminates the variation in alcohol levels and in ingredients used. In addition, it guarantees that a customer's drink will not have anything in it that the customer does not explicitly see. Giving the customer options of existing drinks and customizable features will ensure a smooth and enjoyable drinking experience for everyone.

11 CUSTOMER NEEDS & PRODUCT SPECIFICATIONS

11.1 CUSTOMER INTERVIEWS

TABLE 1: CUSTOMER INTERVIEW 1 - BREANNA GILLETTE - BARTENDER AT GLORY DAYS GRILL – 9/13/2017

Question	Customer Statement	Interpreted Need	Importance
How much alcohol goes into a typical drink?	One shot is 1.5oz but some people like their drinks stronger/weaker	The Drink Maker's (DM's) beverage recipes are adjustable.	3
How long does it take to make one drink?	About 20 seconds. And I am an experienced bartender.	The DM makes drinks quickly.	5
How many drinks do you make a night (on average)	200 drinks, but that also includes people sitting at tables, not just the bar.	The DM makes many drinks before requiring maintenance.	4
How often do people order drinks you do not know how to make?	Very often, and people get frustrated if I don't know how to make what they want	The DM makes custom drinks.	2
What is the most frustrating aspect of your job?	Cleaning bottles/machines When people order drinks that I don't know or take a lot of time.	The DM is easily cleaned.	4
Misc. Comments	It would be cool if it could shake a drink for me.	The DM can mix the drinks mechanically.	5
	It would have to have more than just one type of alcohol to make a bunch of different kinds of drinks.	The DM holds multiple different kinds of alcohol.	4

Table 2: Customer Interview 1 - Cathryn Boggs - Bartender at Captain Billy's Crab Shack – 9/17/2017

Question	Customer Statement	Interpreted Need	Importance
How long does it take to make one drink?	If it is a frozen drink, about 2 minutes. Less than a minute if it isn't frozen	The DM can make drinks quickly. (Frozen drinks are OUT OF SCOPE)	5
How many drinks do you make a night (on average)	Individually, I make roughly 100 drinks per night. Less if it's a week day, more on the weekends.	The DM makes many drinks before requiring maintenance.	4
How often do people order drinks you do not know how to make?	Most people order beer or menu drinks, but I'll get a special request maybe once or twice a week.	The DM is able to produce drinks listed on bar menu. The DM has the ability to program in new drinks. The DM makes custom drinks.	5 3 2
What is the most frustrating aspect of your job?	Being rushed by customers or waiters/waitresses. Being rushed is what causes mistakes and messes.	The DM is able to store more than one order at a time.	3

11.2 INTERPRETED CUSTOMER NEEDS

Table 3: Interpreted Customer Needs

Need Number	Need	Importance
1	The DM's beverage recipes are adjustable.	3
2	The DM makes drinks quickly.	5
3	The DM makes many drinks before requiring maintenance.	4
4	The DM makes custom drinks.	2
5	The DM is easily cleaned.	4
6	The DM mixes the drink mechanically.	5
7	The DM holds multiple different kinds of alcohol.	4
8	The DM is able to produce drinks listed on the bar menu.	5
9	The DM has the ability to program new drink recipes.	3
10	The DM is able to store more than one order at a time.	3

11.3 TARGET SPECIFICATIONS

Table 4: Target Specifications

Metric Number	Associated Needs	Metric	Units	Acceptable	Ideal
1	2	Time to make 1 drink	s	30	10
2	3	Number of drinks before maintenance	integer	100	200
3	7	Number of alcohol types	integer	3	5
4	6	Number of shakes to mix drink	integer	5	7
5	10	Number of drinks in queue	integer	2	5
6	1	Number of adjustable recipes	integer	3	4
7	5	Time to clean	s	700	300

12 CONCEPT GENERATION

12.1 FUNCTIONAL DECOMPOSITION

We determined six distinct functions for the drink mixer to be able to do. For each of the six functions, we determined three different ways to perform that function. This can be seen in the function tree, shown below.

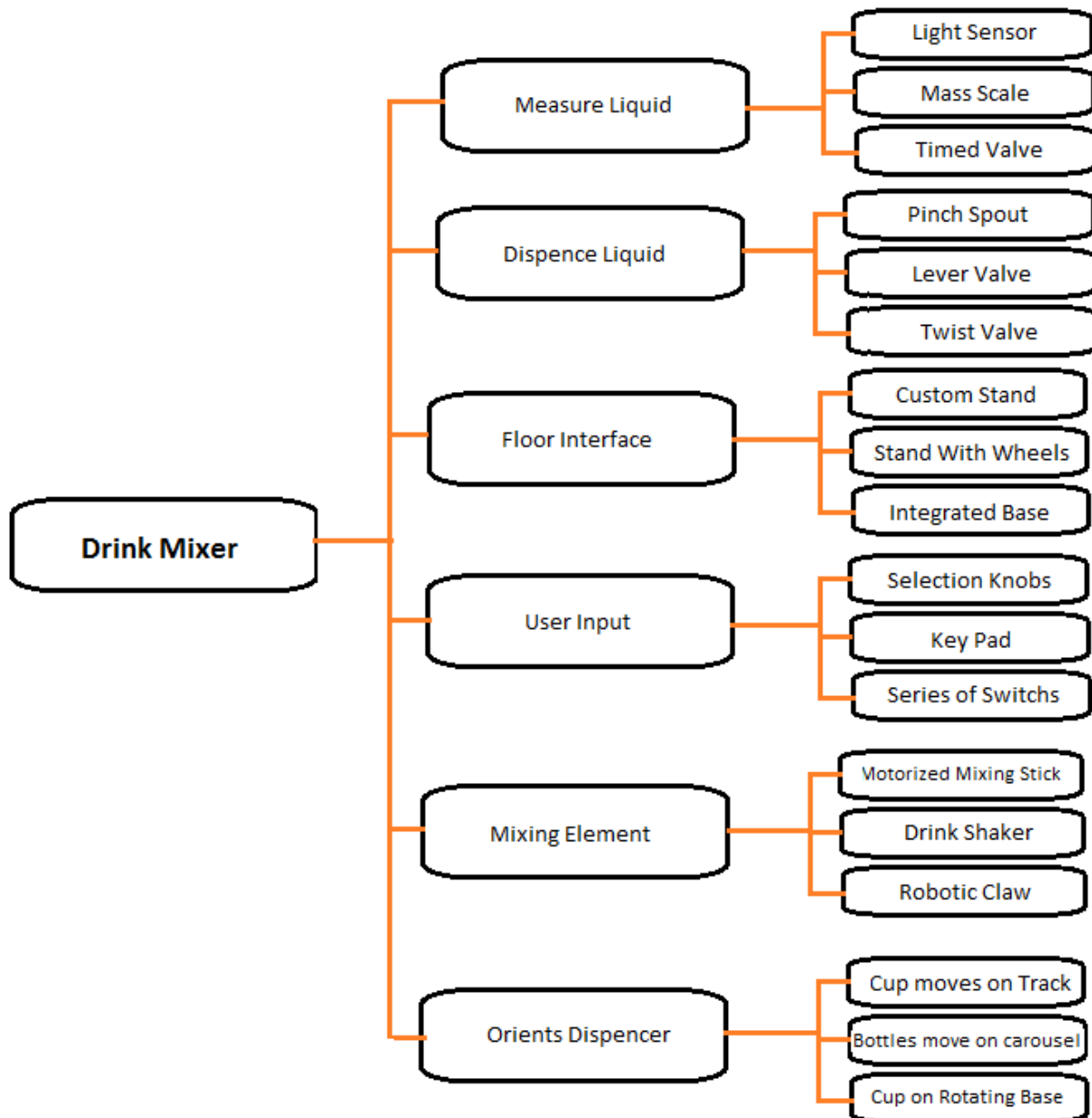

Figure 6: Function Tree

12.2 MORPHOLOGICAL CHART

For each of the determined functions, we drafted each way to perform said function. These are shown in the Morphological chart, shown below. We then chose various options to complete all of the functions the drink mixer needs to perform and combined them into six different concept designs. These designs can be found in the next section.

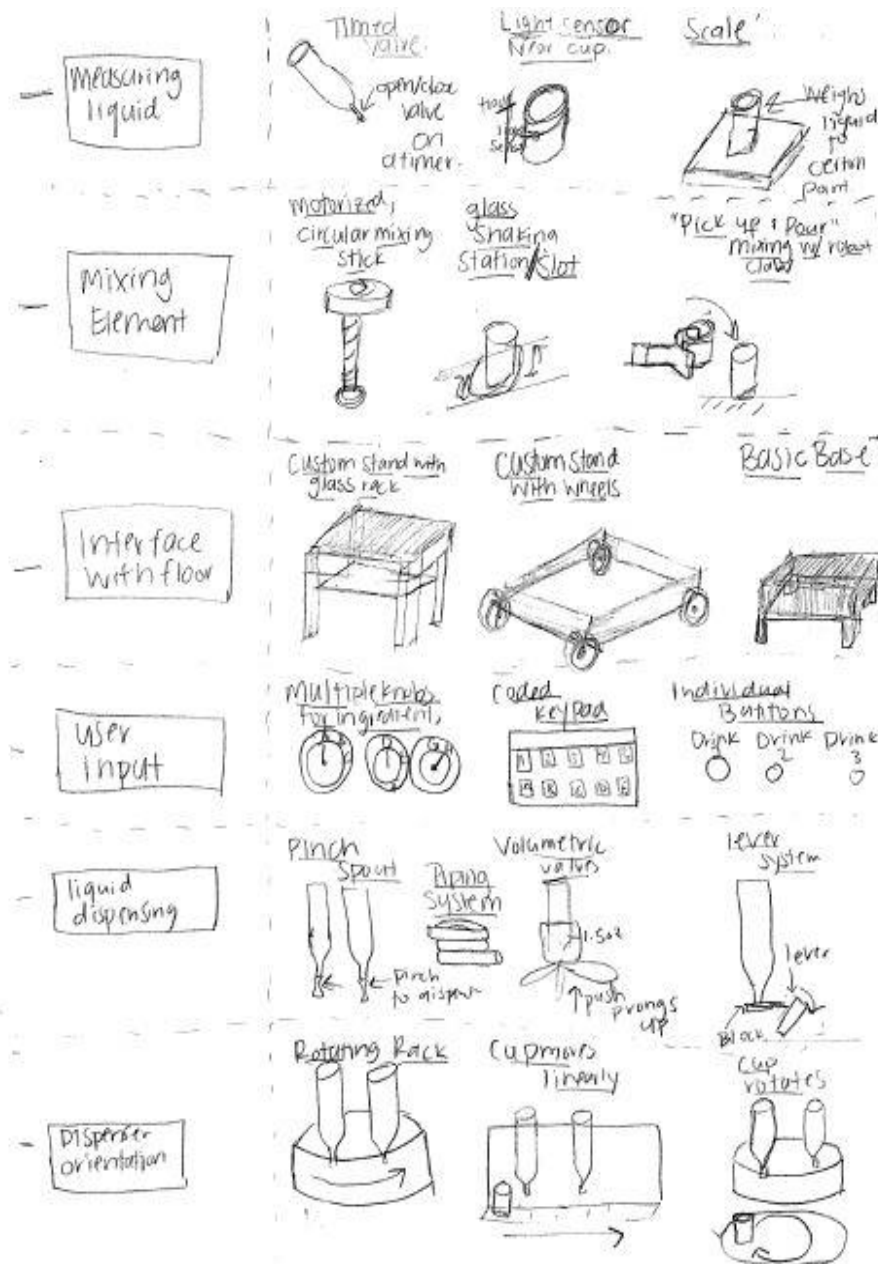

Figure 7: Morphological Chart

12.3 CONCEPT #1 – “INDRUNKINATOR”

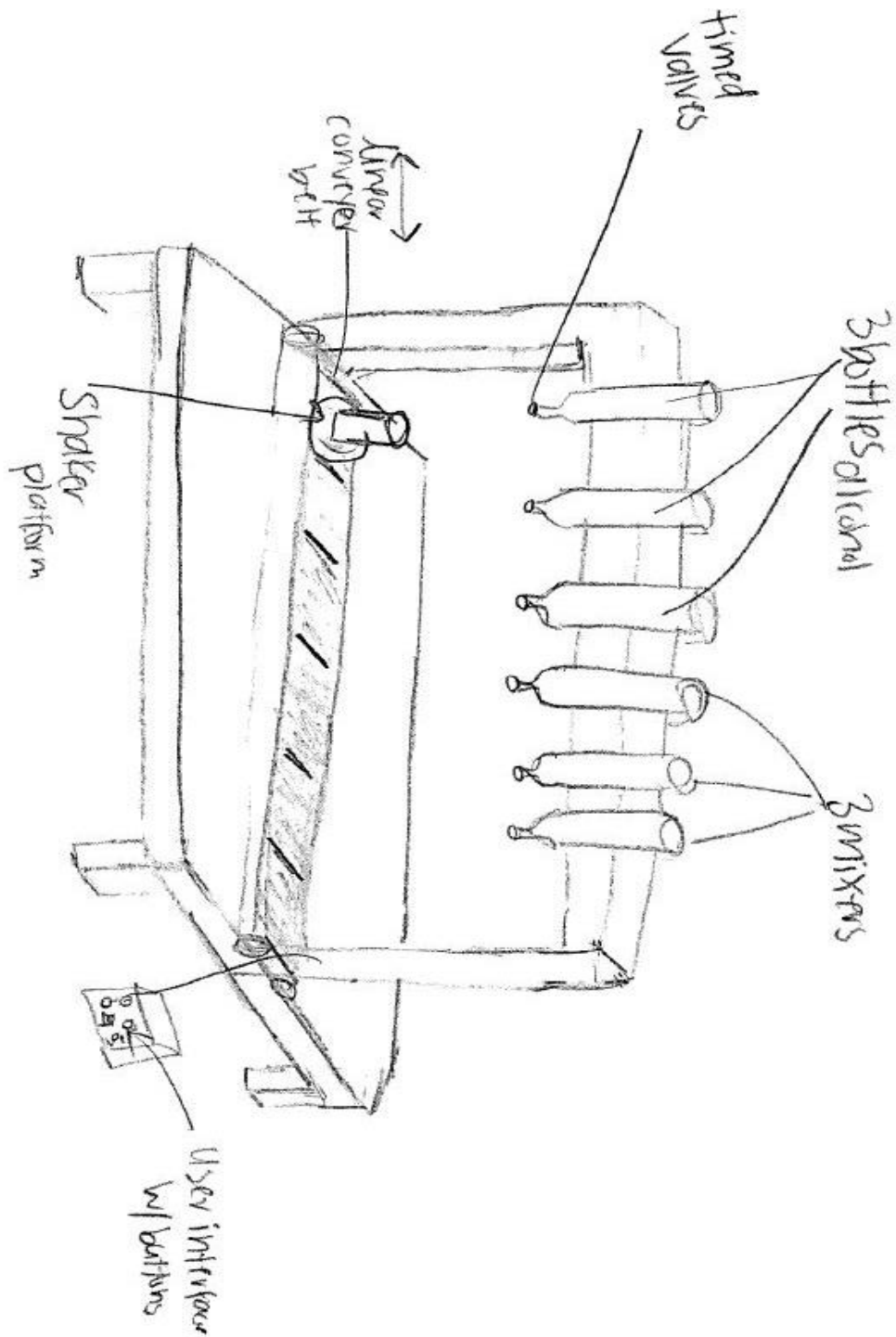

Figure 8: Concept Drawing 1 – The Indrunkinator

12.4 CONCEPT #2 – “DRINK-O-MATIC”

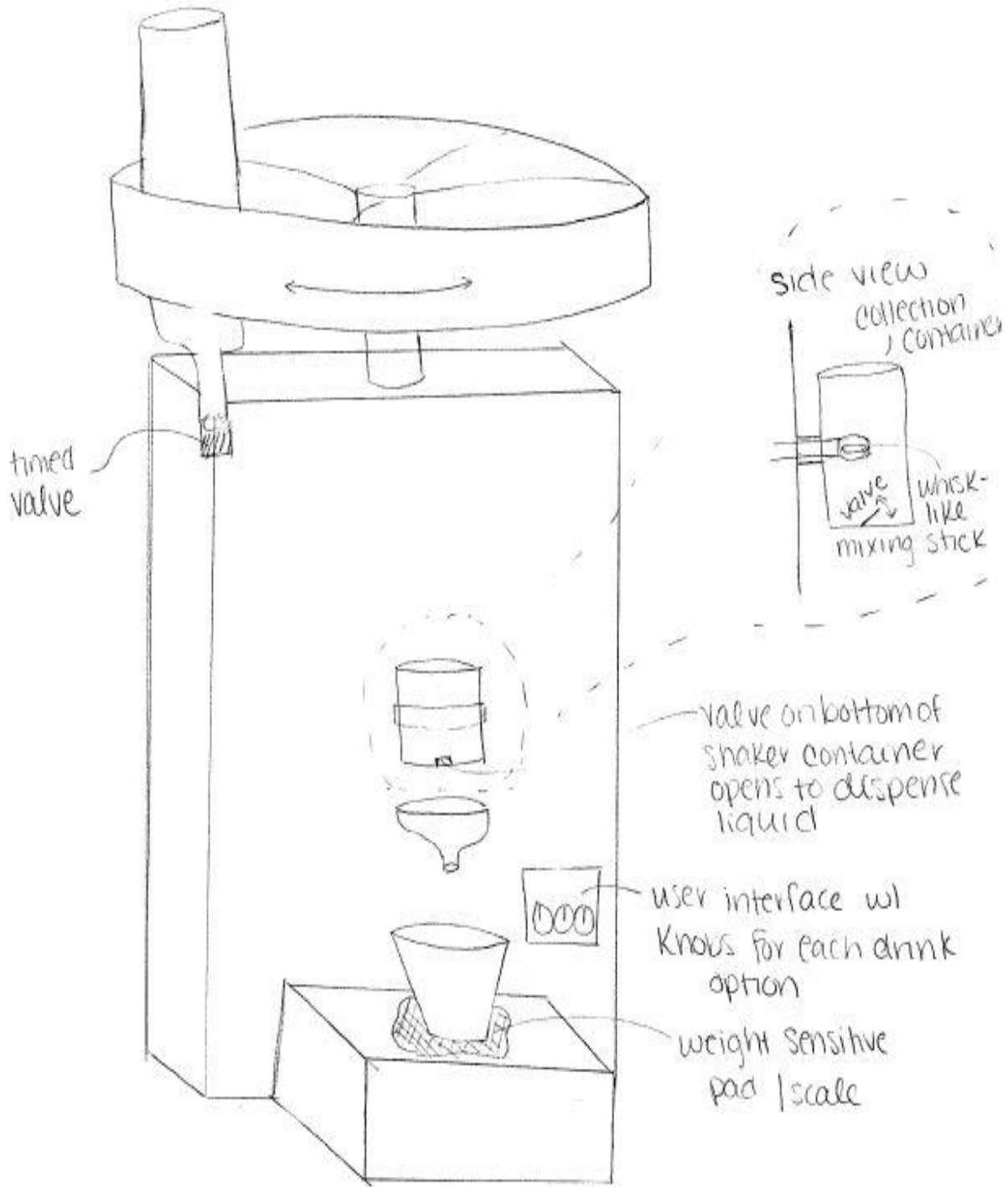

Figure 9: Concept Drawing 2 – Drink-O-Matic

12.5 CONCEPT #3 – “SQUEEZE-O-MATIC”

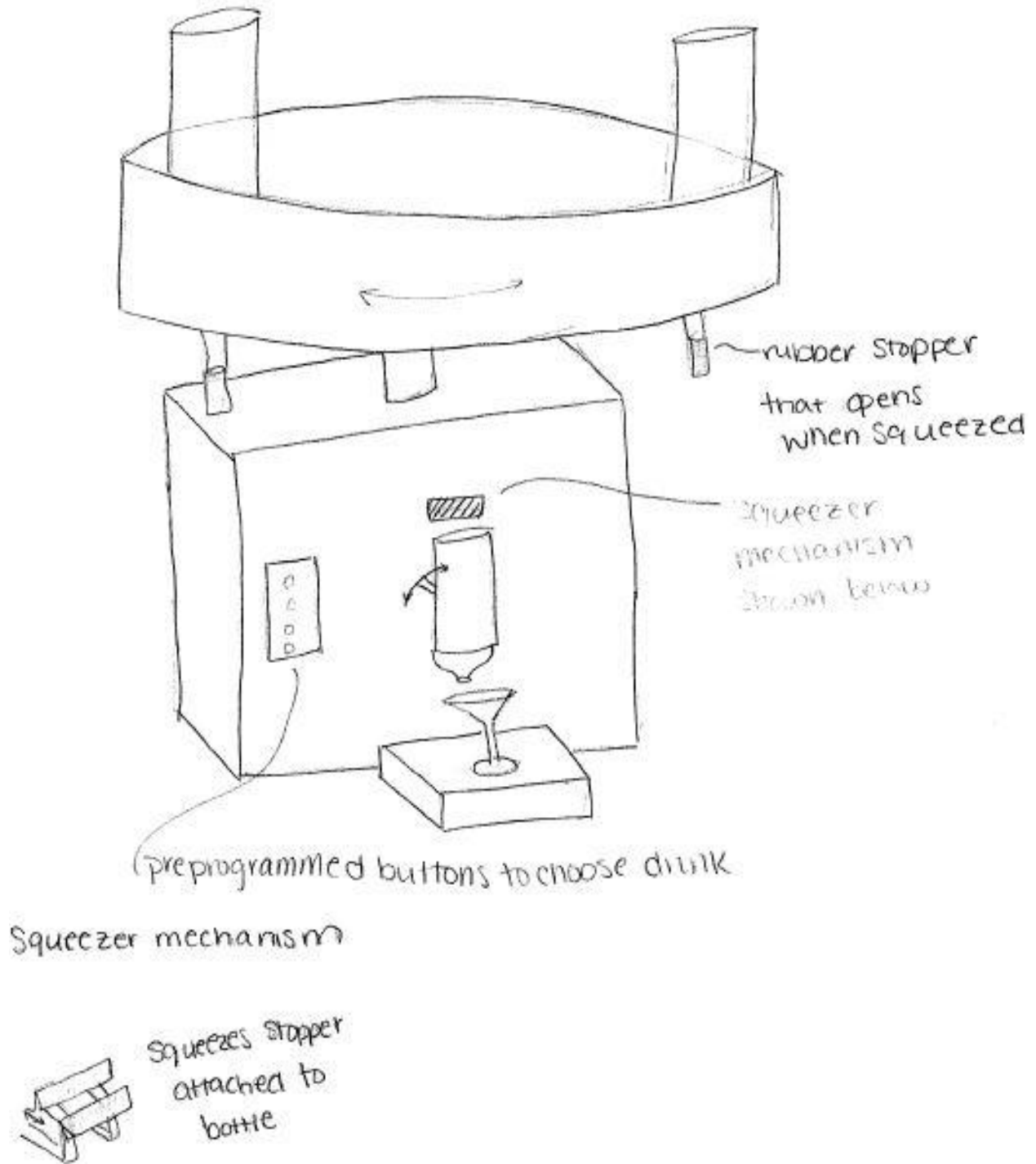

Figure 10: Concept Drawing 3 – Squeeze-o-Matic

12.6 CONCEPT #4 – “BLOODYMARY-GO-ROUND”

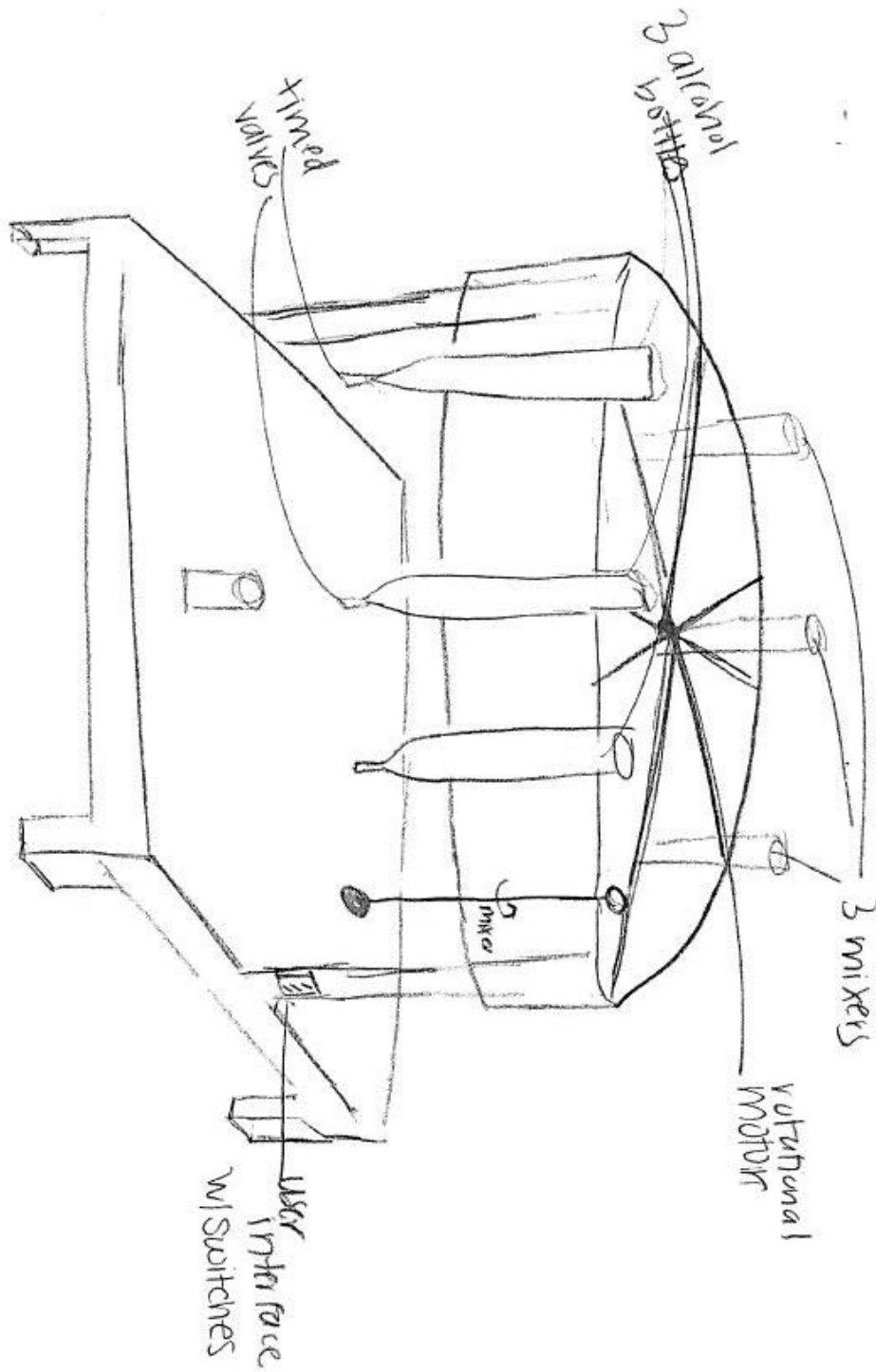

Figure 11: Concept Drawing 4 – BloodyMary-Go- Round

12.7 CONCEPT #5 – “WHEEL OF BOOZE”

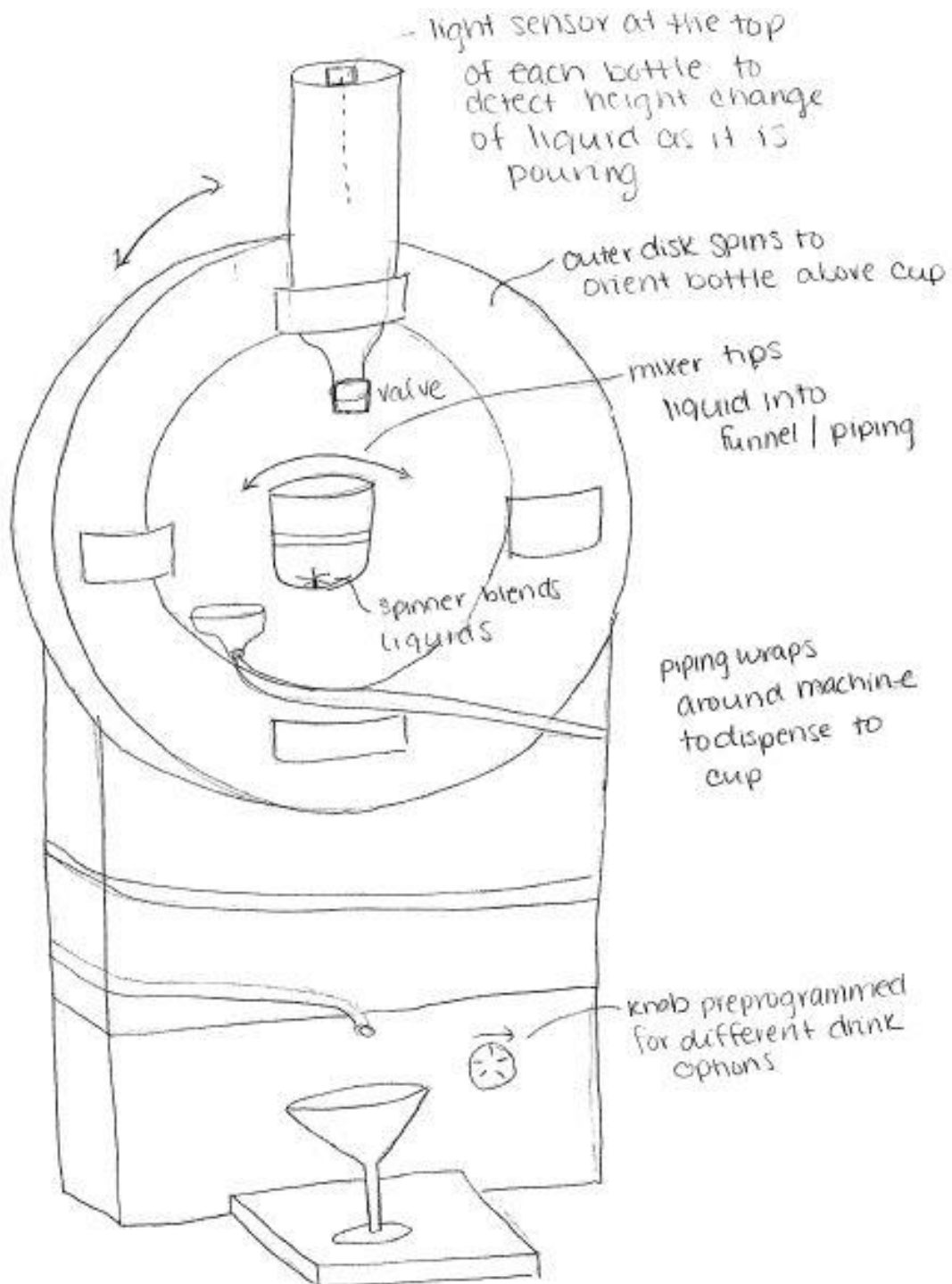

Figure 12: Concept Drawing 5 – Wheel of Booze

12.8 CONCEPT #6 – “MIXoTRON”

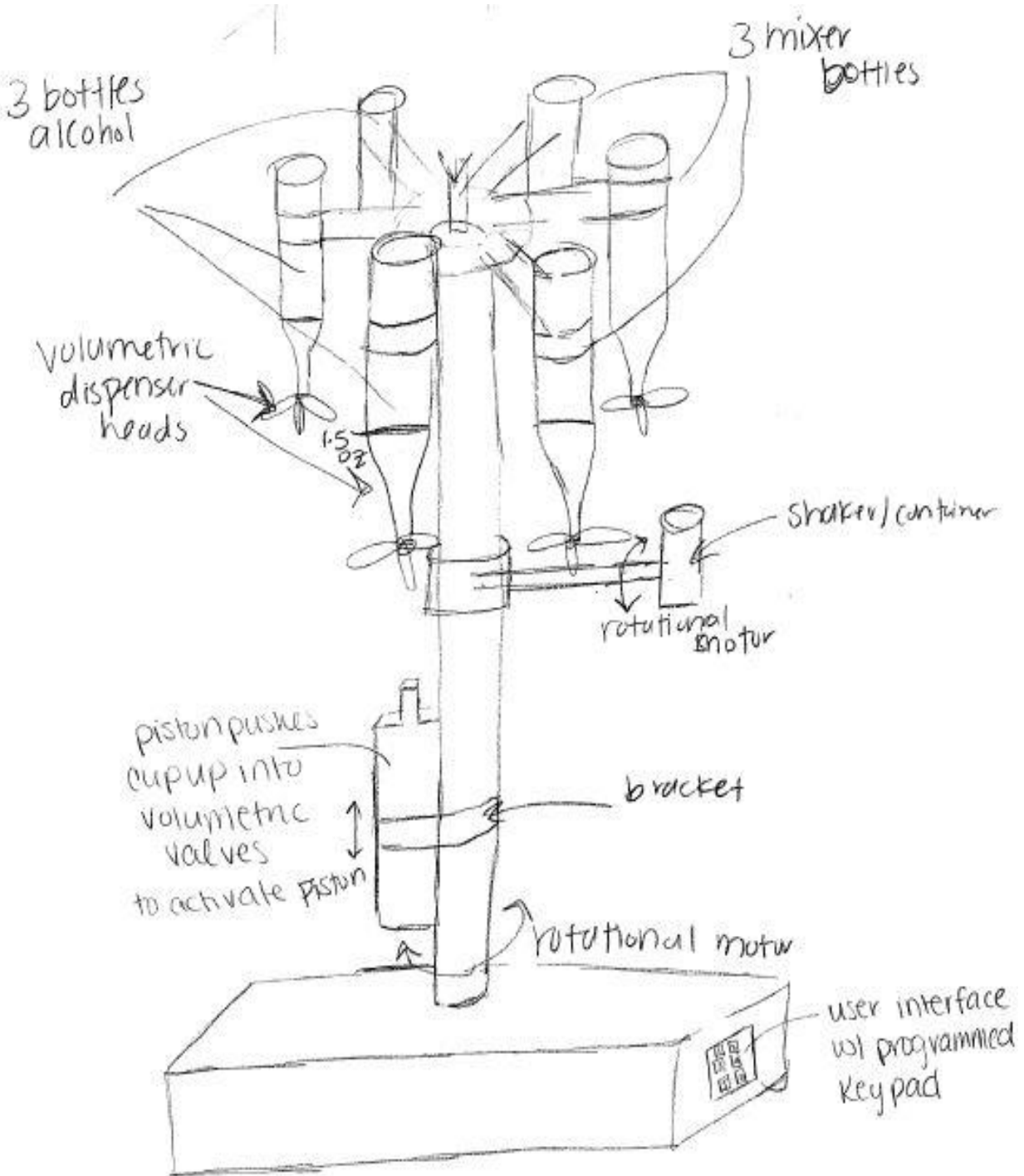

Figure 13: Concept Drawing 6 – MIXoTRON

13 CONCEPT SELECTION

13.1 CONCEPT SCORING MATRIX

The concept scoring matrix below is split into three separate tables, due to spatial constraints.

Table 5: Concept Scoring Matrix (1 of 3)

		Alternative Design Concepts					
							
		Inebriator		Indrunkinator		Drink-o-Matic	
Selection Criterion	Weight (%)	Rating	Weighted	Rating	Weighted	Rating	Weighted
Mechanical safety	22.82	3	0.68	3	0.68	2	0.46
Cost of components	6.93	3	0.21	3	0.21	1	0.07
Ease of Assembly	2.25	3	0.07	2	0.04	2	0.04
Ease of Maintenance	6.52	3	0.20	3	0.20	3	0.20
Aesthetic Appeal	16.74	3	0.50	2	0.33	4	0.67
Entertainment Value	6.52	3	0.20	2	0.13	4	0.26
Consistency of Recipes	16.40	3	0.49	3	0.49	3	0.49
Ease of Programming	2.25	3	0.07	4	0.09	2	0.04
Quality of Mixing	6.52	0	0.00	4	0.26	2	0.13
Accuracy of Pouring into Shaker	6.52	0	0.00	3	0.20	2	0.13
Accuracy of Pouring into Final Cup	6.52	3	0.20	3	0.20	2	0.13
Total score		2.609		2.833		2.625	
Rank		7		5		6	

Table 6: Concept Scoring Matrix (2 of 3)

		Alternative Design Concepts			
					
		Squeeze-o-Matic		BloodyMary-go-round	
Selection Criterion	Weight (%)	Rating	Weighted	Rating	Weighted
Mechanical safety	22.82	3	0.68	3	0.68
Cost of components	6.93	3	0.21	3	0.21
Ease of Assembly	2.25	2	0.04	3	0.07
Ease of Maintenance	6.52	4	0.26	3	0.20
Aesthetic Appeal	16.74	3	0.50	4	0.67
Entertainment Value	6.52	3	0.20	4	0.26
Consistency of Recipes	16.40	2	0.33	4	0.66
Ease of Programming	2.25	3	0.07	4	0.09
Quality of Mixing	6.52	4	0.26	4	0.26
Accuracy of Pouring into Shaker	6.52	4	0.26	2	0.13
Accuracy of Pouring into Final Cup	6.52	4	0.26	3	0.20
Total score		3.075		3.419	
Rank		3		2	

Table 7: Concept Scoring Matrix (3 of 3)

		Alternative Design Concepts			
					
		Ferris Wheel of Booze (Ferris' night out)		MIXoTRON	
Selection Criterion	Weight (%)	Rating	Weighted	Rating	Weighted
Mechanical safety	22.82	2	0.46	3	0.68
Cost of components	6.93	3	0.21	3	0.21
Ease of Assembly	2.25	1	0.02	5	0.11
Ease of Maintenance	6.52	3	0.20	5	0.33
Aesthetic Appeal	16.74	4	0.67	5	0.84
Entertainment Value	6.52	5	0.33	5	0.33
Consistency of Recipes	16.40	2	0.33	5	0.82
Ease of Programming	2.25	3	0.07	3	0.07
Quality of Mixing	6.52	4	0.26	4	0.26
Accuracy of Pouring into Shaker	6.52	3	0.20	5	0.33
Accuracy of Pouring into Final Cup	6.52	4	0.26	3	0.20
		Total score	2.991	4.164	
		Rank	4	1	

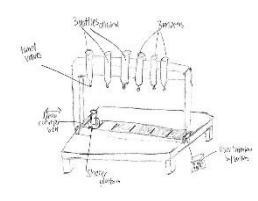
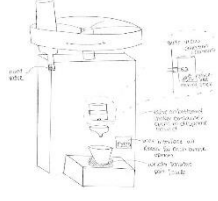
According to the Scoring Matrix, the MIXoTRON is the winning design with a total score of 4.164 out of 5. The BloodyMary-go-Round was the second-place concept with a score of 3.419 out of 5. The third-place concept with a score of 3.075 out of 5. All of the proposed concepts scored better than the base-line concept, the Inebriator, mostly because of the fact that the Inebriator does not have any kind of mixing mechanism.

13.2 EXPLANATION OF WINNING CONCEPT SCORES

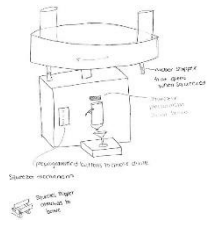
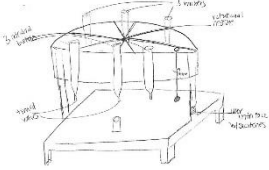
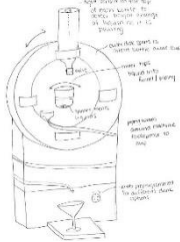
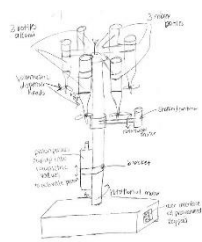
The MIXoTRON scored significantly higher in 6 of the 11 selection criterion than the other 5 designs: ease of assembly, ease of maintenance, aesthetic appeal, entertainment value, recipe consistency, and mixing quality. The bottles and shaker mechanism are both connected to the center shaft, making the design easy to assemble, as well as simple and pleasing to look at. The three different movements of this machine make it very entertaining to watch. The top of the assembly, where all the bottles are stored, will rotate around the shaft to orient a specific bottle above the shaker cup, according to the recipe chosen. The piston will then raise to lift the cup into the push valve on the bottle, dispensing exactly 1.5 oz. of liquid into the cup. This will repeat until the recipe for the chosen drink is complete. Then, the shaker arm will shake the cup, rotating it about the shaker arm roughly -15° to 15° . All of these moving parts will make the MIXoTRON a very interesting piece of machinery. The volumetric dispenser heads provide the most consistency in the amount of liquid dispensed from the bottles, as opposed to a timer mechanism. The volumetric dispenser releases exactly 1.5 oz. of liquid every time the dispenser is pressed. The shaker will rotate roughly -15° to 15° , making the mixing thorough and consistent. The other 5 selection criterion were relatively similar to the other designs.

13.3 EXPLANATION OF SECOND-PLACE CONCEPT SCORES

The Bloody Mary-Go-Round scored very high in the aesthetic categories. The rotation of the bottles is a very dynamic and exciting motion, that many will find entertaining. In addition, since it has a component that enters the cup and mixes the liquid inside, it scored above average in the Mixing Quality criteria. A mechanical stirrer would mix the drink fairly well, however there are a few problems that come with it: the stirrer would need to be cleaned between each drink, and the motion is less dynamic and entertaining. It is because of these problems that this concept was not the winning design. It also scored above average in the “ease of programming,” because it the main part of the mechanism requires a rotational motor, which can be easily programmed by defining one bottle as a “zero” radian value, and programming the rotation relative to that bottle. Most of the other selection criterion were relatively the same as the other options, however there one that was given a low score. The accuracy of pouring the liquids into the shaker is lower than average is due to difficulties in measuring liquid flow using timed valves.

13.4 EXPLANATION OF THIRD-PLACE CONCEPT SCORES

The Squeeze-o-matic ranks high in a few of the selection categories. The mixing quality, the accuracy of pouring the liquids into the shaker and the accuracy of pouring the shaken liquids into the cup were all ranked relatively high, seeing as there is less overall movement to the machine. With less movement

comes less variability in these categories, as well as less probability of making a mess. However, that also makes the design a little duller and less exciting, thus the aesthetic ranking is fairly low compared to the other top-ranking concepts. Most of the other criterion were ranked as fairly average, although there are some areas where this design is less than acceptable: One of these areas is the consistency of recipes. Mechanically squeezing a rubber stopper wouldn't be as consistent as some of the other means, seeing that the time required to dispense one oz. of liquid would be different depending on how much liquid is in a specific bottle. Not only would this be very hard to program and calibrate into the machine, but the amount of error in the process would be immense in comparison to the volumetric dispensing option used in the winning concept.

13.5 SUMMARY OF EVALUATION RESULTS

According to the Weighted Scoring Matrix, the winning concept needed to be efficient, consistent, and aesthetically pleasing. After comparing the 7 designs, including the baseline product, the Inebriator, the winning concept was the concept with the most entertaining design and the most consistent dispensing mechanism; the MIXoTRON. Although the second- and third-place concepts also ranked fairly high in comparison to other designs, the biggest design flaw in both designs was the timed dispensing mechanism. After discussion, it was decided that the amount of effort it would take to program and calibrate these timers would simply be in vain due to the massive amount of error characteristic of this measuring technique.

14 EMBODIMENT & FABRICATION PLAN

14.1 ISOMETRIC DRAWING WITH BILL OF MATERIALS

The following figures below show the design in multiple different views: isometric, front, side, and top, as well as an exploded view, created using the functionalities of Solidworks. There is also a bill of materials, as provided by Solidworks.

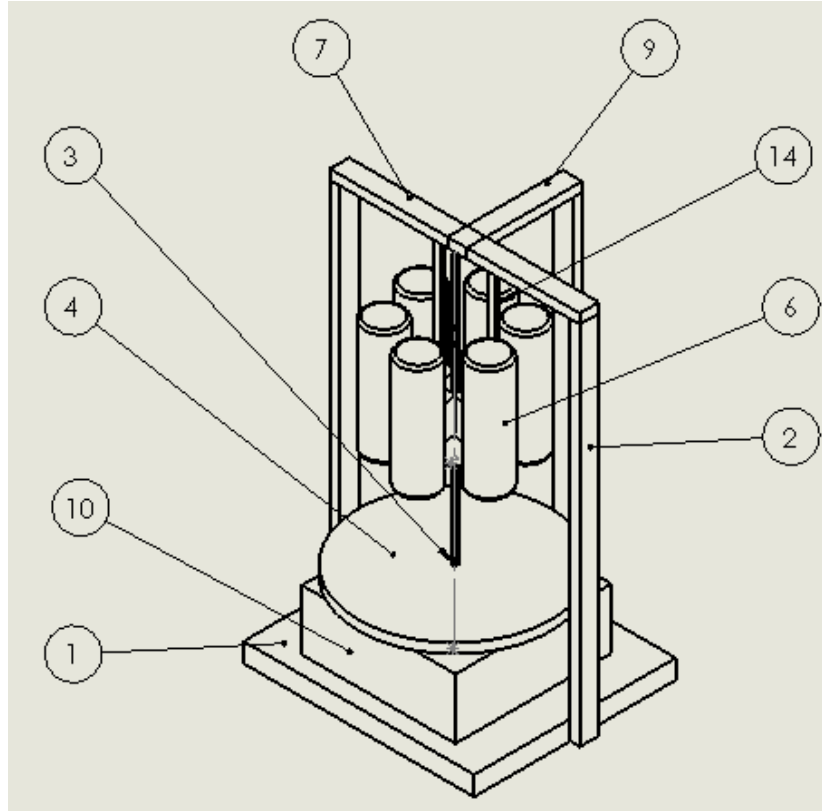

Figure 14: Isometric Drawing

ITEM NO.	PART NUMBER	DESCRIPTION	QTY.
1	FINALbase	plywood	1
2	sidesofstructure	plywood	3
3	99065A135	threated rod	1
4	lazysusan	plexiglass	1
5	95462A033	HEXNUT	1
6	Base2	plywood	1
7	topacross	plywood	1
8	motor		1
9	tophalf	plywood	1
10	box	plywood	1
11	wheel		1
12	6031K160_CORROSION-RESISTANT TURNTABLE	TURNTABLE	1
13	woodslab	plywood	1
14	stickgaurd	plywood	2

Figure 15: Bill of Materials

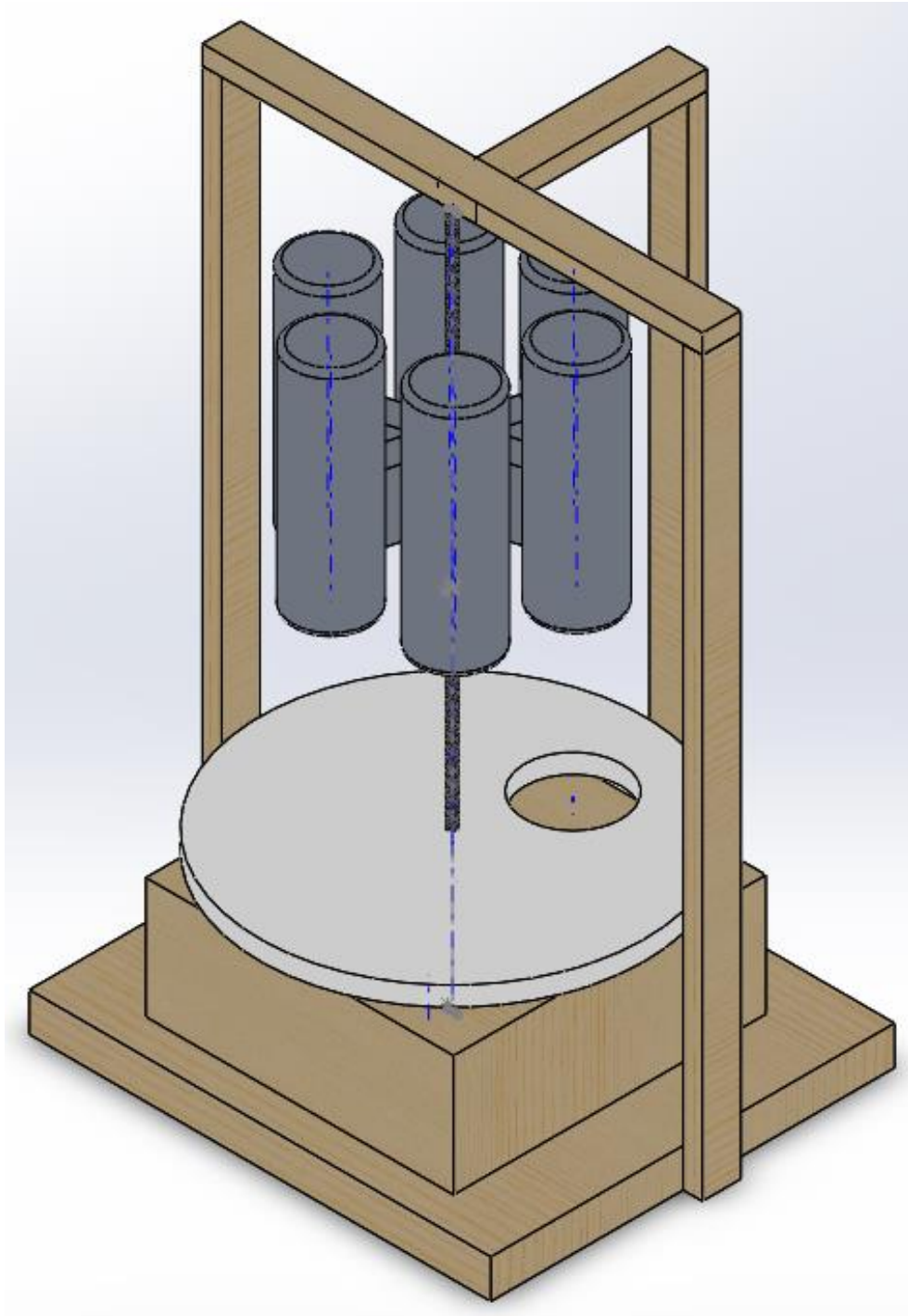

Figure 16: Isometric View

14.2 EXPLODED VIEW

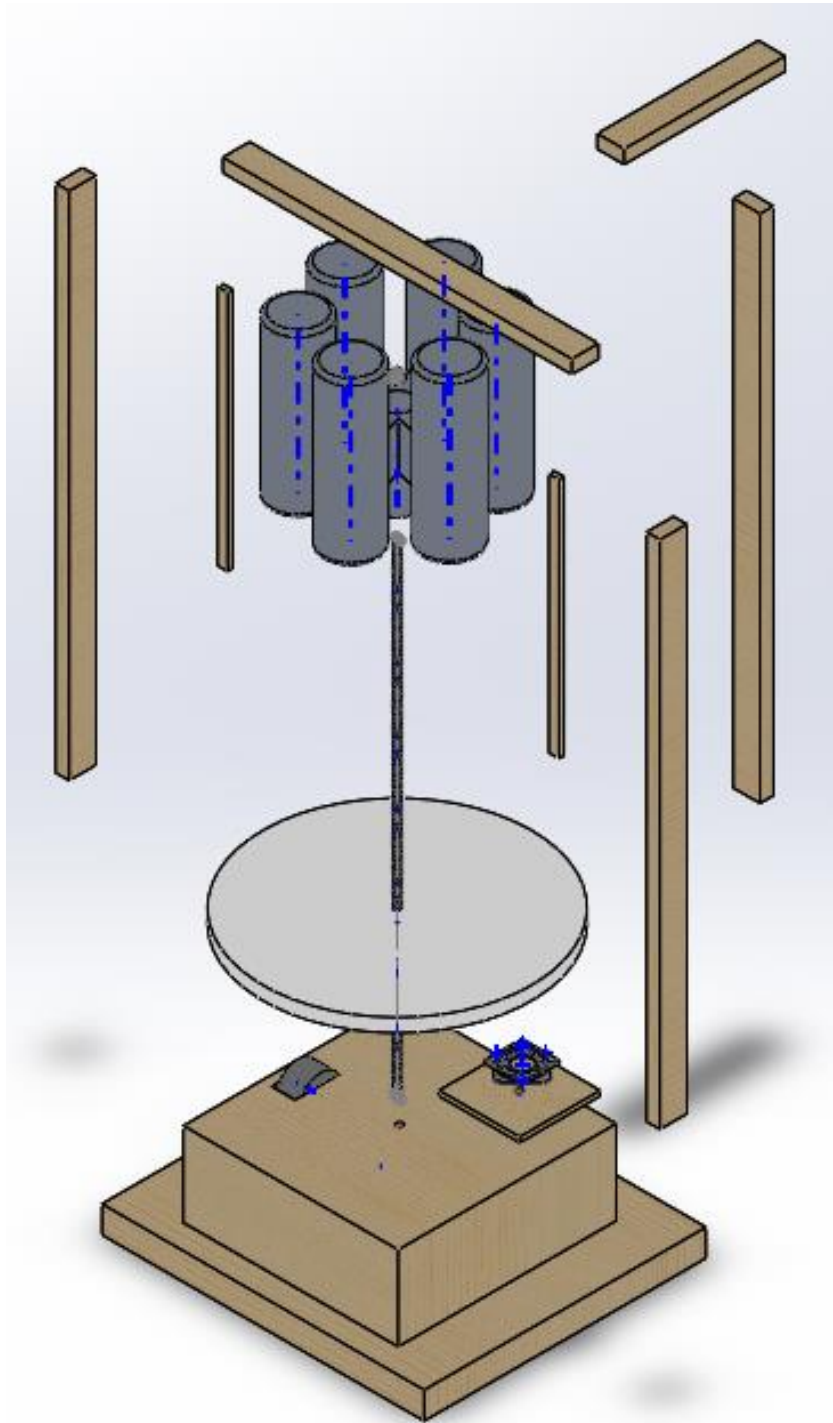

Figure 17: Exploded View

14.3 ADDITIONAL VIEWS

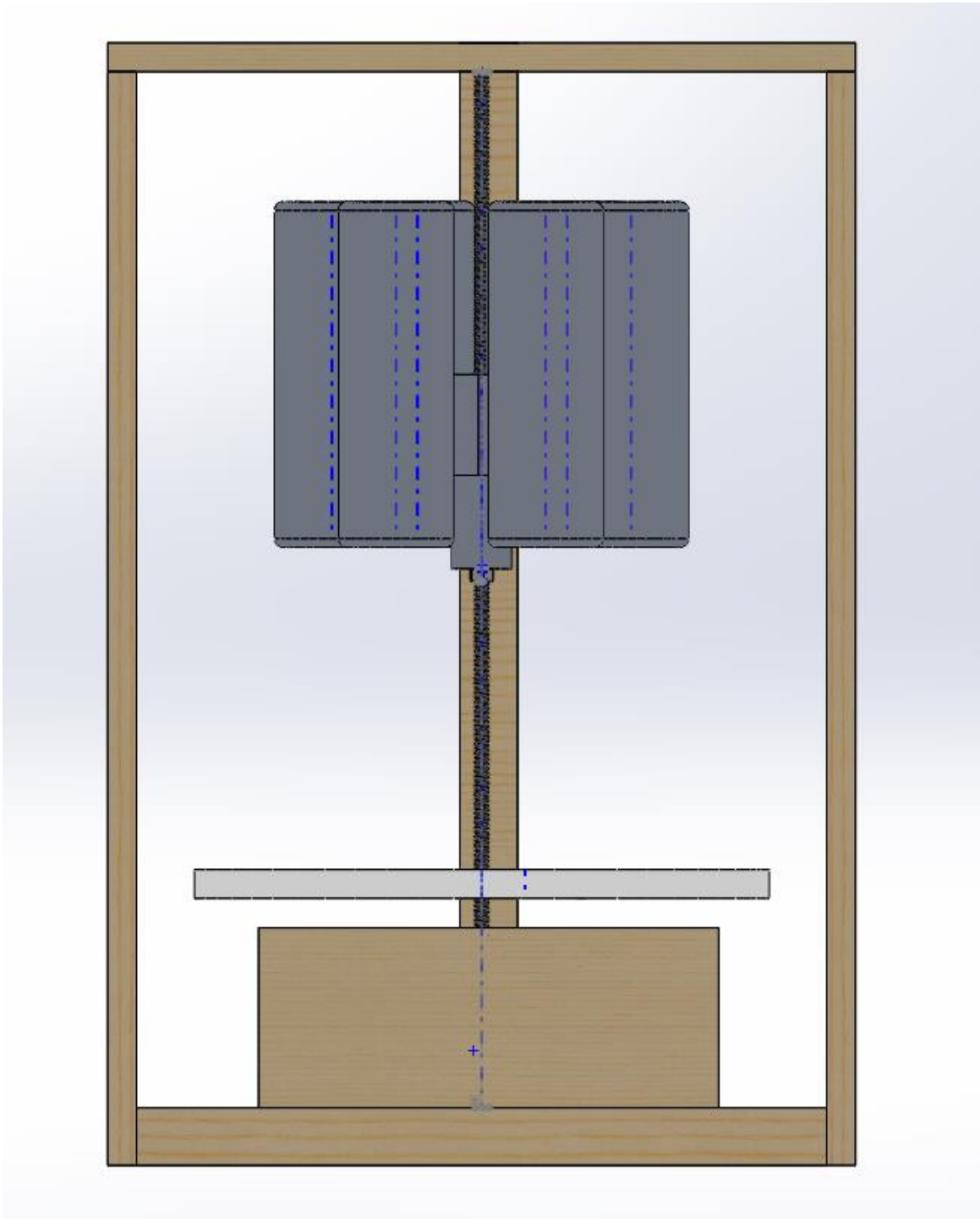

Figure 18: Front View

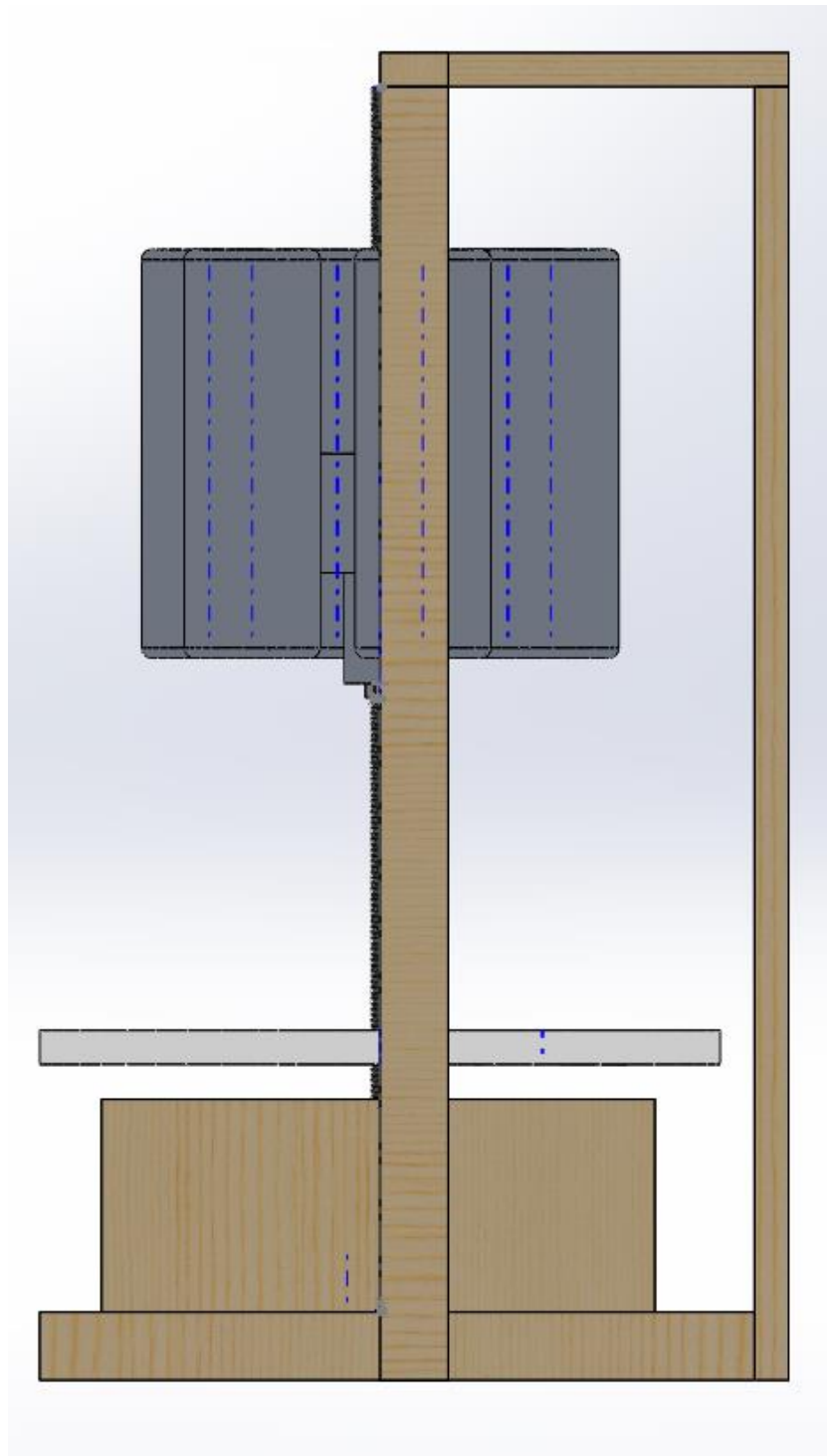

Figure 19: Side View

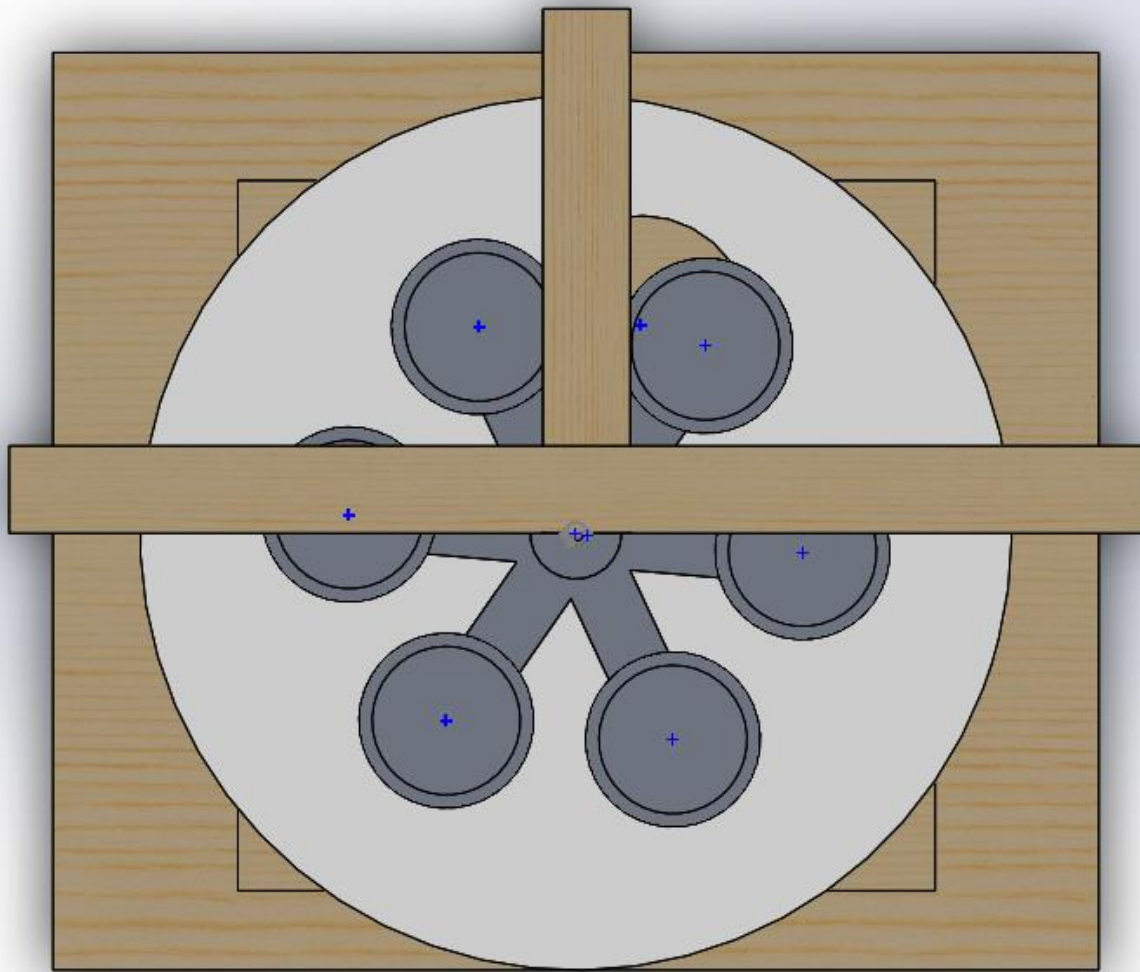

Figure 20: Top View

15 ENGINEERING ANALYSIS

15.1 ENGINEERING ANALYSIS RESULTS

15.1.1 Motivation

There was one main area of focus for analysis: the lead screw mechanism. We needed to determine the amount of torque required to drive the lead screw and compare that to the amount of torque the motor we chose could put out. The motor we chose did not have any identifying labels or marks, so we needed to find its inherent characteristics to determine if that motor would satisfy the requirements of the project.

15.1.2 Summary Statement of the Analysis

The engineering analysis of the lead screw mechanism was done by pen-to-paper calculations. To summarize, we experimentally found the stall torque of the motor chosen to drive the lead screw, calculated the torque required to drive the lead screw with the applied load, found the gear ratio needed to allow the chosen motor to meet the requirements of the project, and compared the calculated ideal speed of the lead screw to the actual speed observed during product testing.

Finding the torque required to drive the lead screw was the most important step in the engineering analysis. Upon researching the lead screw mechanism, we found that the torque required to drive the lead screw is simply the torque required to lift the load a given distance (lead). The raise torque was found using the following equation from *Machine Design*, 4ed [1].

$$T_{raise} = \frac{Fd_m}{2} \left(\frac{L + \pi\mu d_m}{\pi d_m - \mu L} \right) \quad [1]$$

where F is the load, d_m is the mean diameter, L is the lead, and μ is the coefficient of friction between, in our case, the steel nut and the steel lead screw.

With further research, we found that there is a critical speed at which a lead screw can be driven. Common practice is to run the lead screw at maximum 80% of the critical speed. We needed to determine whether our performance goals required driving our lead screw mechanism at greater than 80% of the critical speed. This was done using the following equation, also from *Machine Design*, 4ed [1].

$$N = \frac{(4.76 \times 10^6) d_m C}{L^2} \quad [2]$$

where d_m is the mean diameter, L is the lead, and C is the constant describing how the lead screw is fixed. In our lead screw mechanism, we chose a “simple-simple” support for the lead screw.

The only other equations used in this analysis were basic gear ratio relationships, as seen below.

$$GR = \frac{T_{out}}{T_{in}} = \frac{\omega_{in}}{\omega_{out}} = \frac{\#teeth\ out}{\#teeth\ in} \quad [3]$$

where T is torque, ω is the rotational speed, and $\#teeth$ is the number of teeth on the gear, while the subscript “in” represents the input gear on the motor and the subscript “out” represents the output gear on the lead screw.

15.1.3 Methodology

There were many steps involved in analyzing the lead screw mechanism. First, we found the stall torque of the motor chosen to drive the lead screw. This was done using a torque gauge borrowed from the

Washington University ESE department. Five measurements of the stall torque were taken at two different voltages, 9V and 12V. The figure below shows the results of this experiment.

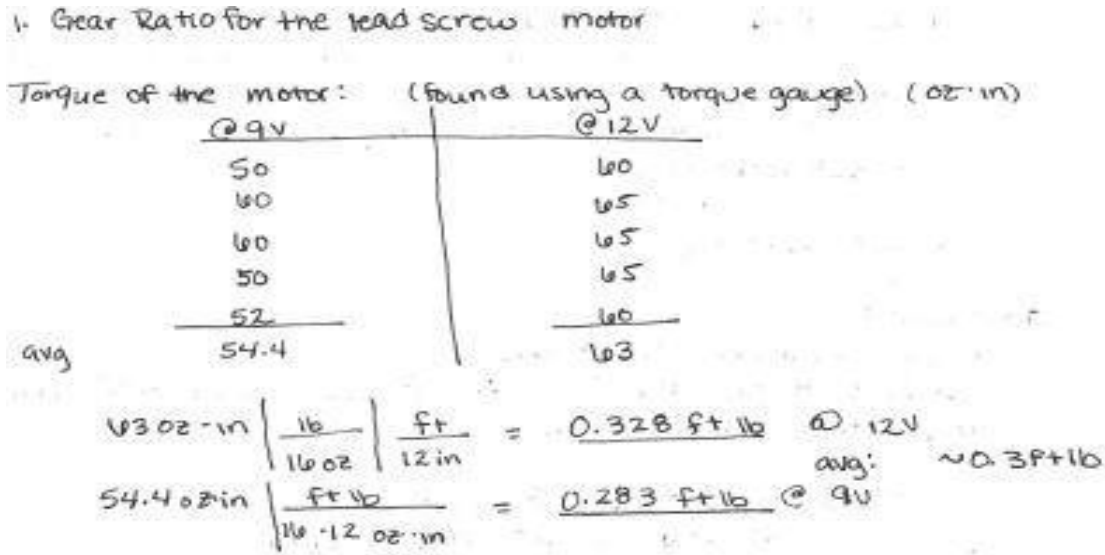

Figure 21: Finding the torque of the lead screw motor

We then found the torque required to drive the lead screw. To do this, we found the total load applied to the lead screw; i.e. the weight of the bottles and the carousel. We decided that the carousel would hold at most four full 750mL bottles of alcohol. The calculation of the total load can be seen below.

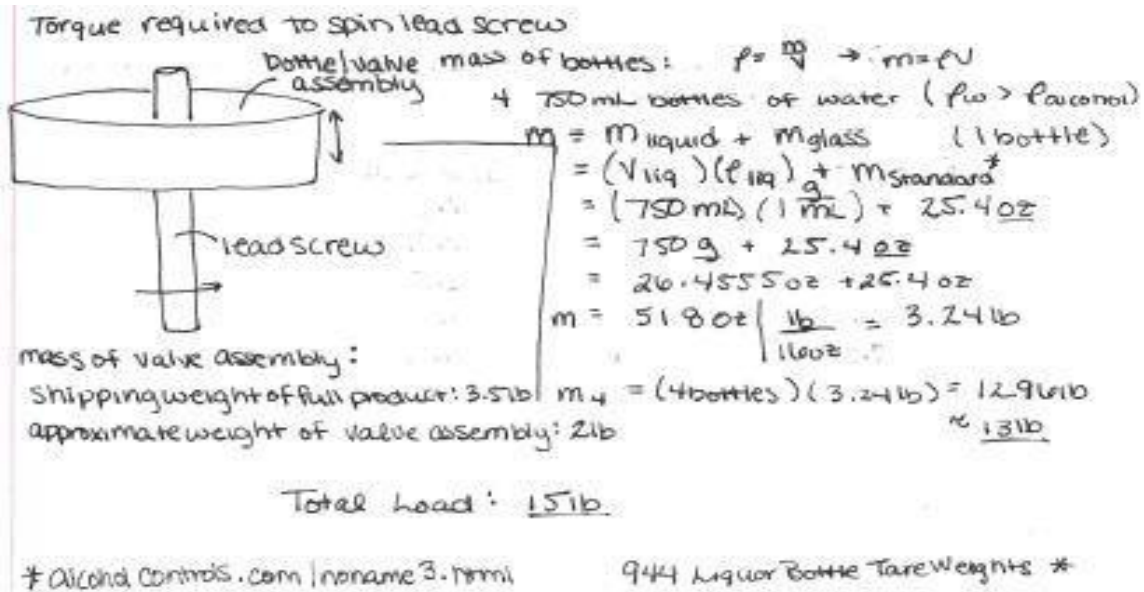

Figure 22: Finding the load on the lead screw

The torque of the lead screw was then found using Equation 1.

Torque of a lead screw:

$$T_{\text{raise}} = \frac{F d_m}{2} \left(\frac{L + \pi \mu d_m}{\pi d_m - \mu L} \right)$$

$$= \frac{(15 \text{ lb})(\frac{1}{2} \text{ in})}{2} \left(\frac{(2 \text{ in}) + \pi (0.25)(\frac{1}{2} \text{ in})}{\pi (\frac{1}{2} \text{ in}) - (0.25)(2 \text{ in})} \right)$$

$$= 8.38 \text{ lb}\cdot\text{in} \left| \frac{\text{ft}}{12 \text{ in}} \right.$$

* steel on steel

$F = \text{load} = 15 \text{ lb}$
 $d_m = \text{mean diameter} = \frac{1}{2} \text{ in}$
 $\mu = \text{coef. of friction} = 0.25$
 $L = \text{lead} = 2 \text{ in}$

$T_{\text{raise}} = 0.698 \text{ ft}\cdot\text{lb}$

Figure 23: Finding the torque required to drive the lead screw

Since the torque required to drive the lead screw was determined to be greater than the stall torque of the chosen motor, we needed to use gears to step up the motor torque. Because we only knew the stall torque of the motor, we knew we had to incorporate a factor of safety into deriving the gear ratio, otherwise we would be relating the required torque to drive the lead screw to the ultimate torque of the motor when it is stalled. Thus, the gear ratio was calculated for five different safety factors ranging from 1 to 2. This can be seen in the figure below.

Gear Ratio:

Torque required: 0.698 ft·lb
 a Factor of Safety: 1.5 \therefore Torque required = 1.05 ft·lb
 Torque of motor: ~0.3 ft·lb

Output Torque = Input Torque * Gear Ratio
 $GR = \frac{T_{\text{out}}}{T_{\text{in}}} = \frac{1.05 \text{ ft}\cdot\text{lb}}{0.3 \text{ ft}\cdot\text{lb}} = 3.49$

\therefore gear on lead screw should be 3.5 x bigger than gear on motor

Factor of Safety	Gear Ratio
1	2.3
1.25	2.9
1.5	3.5
1.75	4.1
2.0	4.7

Figure 24: Calculating the gear ratio required from the motor to the lead screw for different factors of safety

Once we determined a set of gear ratios that would provide the required torque, we needed to look at the speed requirement of the system. In order to meet our performance goal of making one drink in less than 30 seconds, we decided that the lead screw would need to drive the carousel up or down 2 inches in 5 seconds. Using this information, we were able to determine how fast the lead screw would need to turn; then using the set of gear ratios we were able to determine a set of corresponding motor speeds needed to fulfill the speed requirement. These calculations can be found below.

2. Motor Speed for Linear motion

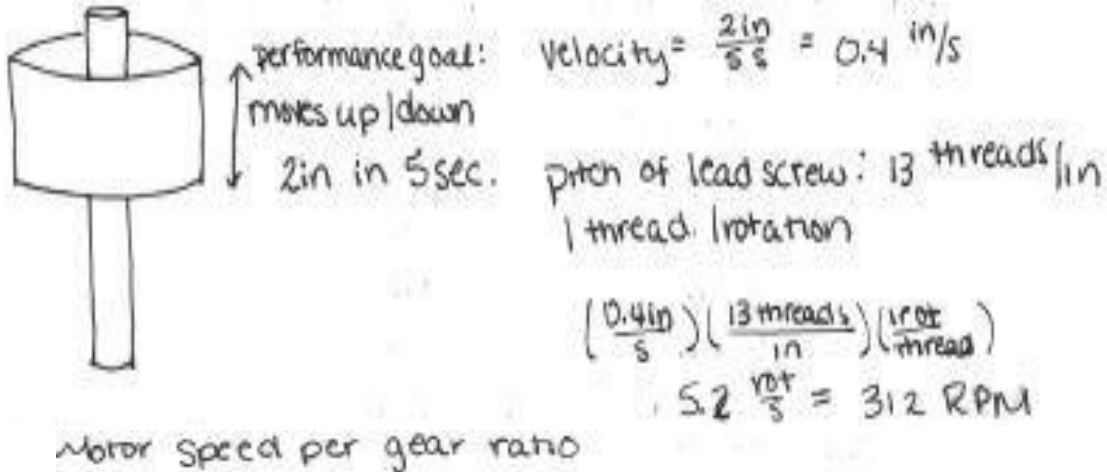

$$\frac{\omega_{in}}{\omega_{out}} = GR \rightarrow \omega_{in} = GR (312 \text{ RPM})$$

Gear Ratio	ω_{in} (RPM)
2.3	717.6
2.9	904.8
3.5	1092.0
4.1	1279.2
4.7	1466.4

Figure 25: Finding the required motor speed

Upon researching the mechanics of the lead screw mechanism, we found that there was a critical speed at which a lead screw can be driven. Using Equation 2, we were able to determine whether we were at risk of running our lead screw at speeds exceeding the critical speed. This calculation can be found below.

Critical speed of a lead screw:

$$N = \frac{(4.76 \times 10^6) (d_m) C}{L^2}$$

d_m = diameter = 0.5 in
 L = length = 3 ft = 36 in
 C = "fixed" constant = 1 "simple simple"

$$N = \frac{(4.76 \times 10^6) (0.5 \text{ in}) (1)}{(36 \text{ in})^2}$$

$$N = 918 \text{ RPM}$$

80% of critical speed = 734.16 RPM

312 RPM is @ 34% of critical speed ✓

Figure 26: Finding the critical speed of the lead screw

Using the information gathered during this analysis, we found gears that would step up the motor torque enough to power the lead screw. We chose a gear with 15 teeth for the motor and a gear with 60 teeth for the lead screw, giving a gear ratio of 4 (therefore a factor of safety of 1.72). Upon implementation, it was found that the actual linear speed of the carousel is much slower than anticipated, at 1 inch in 10 seconds. Thus, we decided to continue our analysis of the motor by constructing the torque-speed curve. This was done by calculating the speed and torque of the motor under the load of the lead screw. The calculations and resulting curve can be found below.

3. Determine Actual Motor Speed / Torque

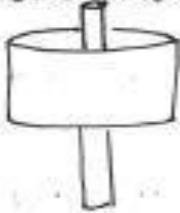

actual linear speed: 1 in in 10 s = $0.1 \frac{\text{in}}{\text{s}}$
 pitch of lead screw: 13 threads/in
 $(0.1 \frac{\text{in}}{\text{s}}) (\frac{13 \text{ threads}}{\text{in}}) (\frac{1 \text{ rotation}}{\text{thread}})$
 $= 1.3 \frac{\text{rotations}}{\text{s}} = 78 \text{ RPM}$

Motor Speed per Chosen Gear Ratio
 Gear Ratio: $\frac{\# \text{ teeth out}}{\# \text{ teeth in}} = \frac{60}{15} = 4$
 $w_{in} = w_{out} \cdot GR$
 $w_{in} = (78 \text{ RPM}) (4)$
 $w_{in} = 312 \text{ RPM}$

Motor Torque per Gear Ratio
 $T_{in} = \frac{T_{out}}{GR}$
 $T_{in} = 0.738 \text{ ft} \cdot \text{lb} / 4$
 $T_{in} = 0.185 \text{ ft} \cdot \text{lb}$

Figure 27: Determining the actual speed of the motor

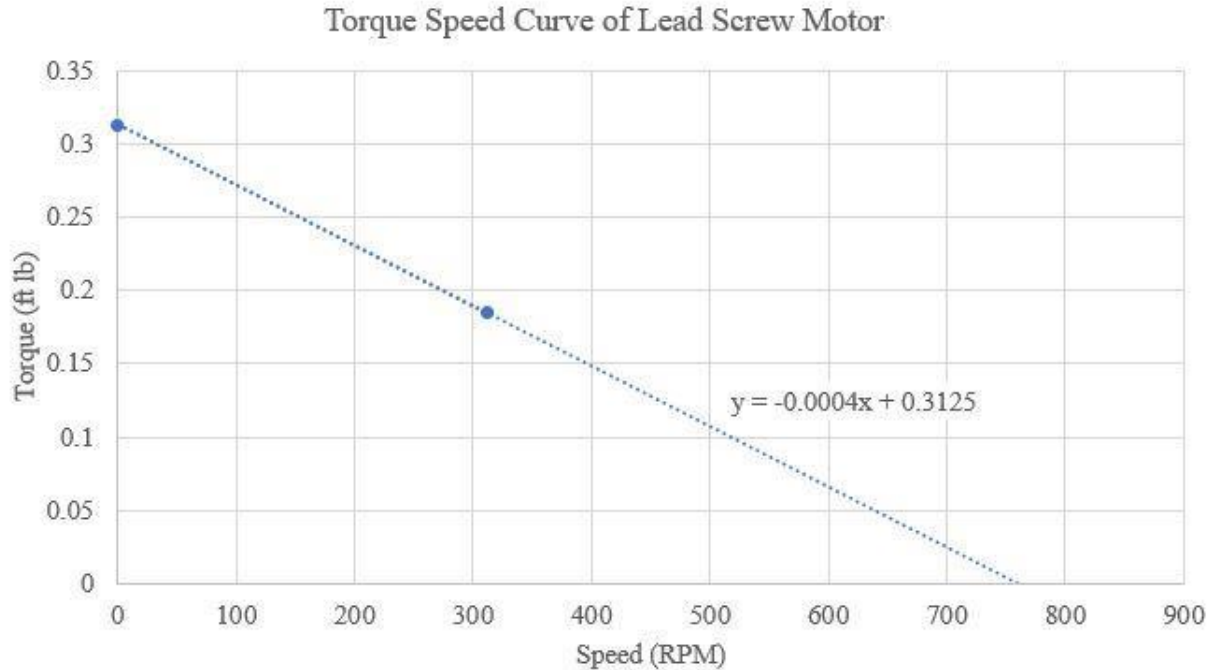

Figure 28: Torque speed curve of the lead screw motor

15.1.4 Results

In performing this analysis, it was found that the chosen motor is adequate to be used to drive the lead screw. For multiple factors of safety, we found a reasonable gear ratio that would provide the torque required to raise and lower the load on the lead screw. Although we found that the motor spins the lead screw slower than required at the gear ratio we chose (4:1), we believe that we can fix this by adjusting the gear ratio to a smaller value. While this would increase the amount of torque the motor would need to apply to the lead screw, it would increase the rotational speed of the lead screw. We determined that the increase of applied torque would not be an issue, due to the factor of safety implemented within the calculations. Essentially, we have the room to increase the motor torque to get an increase in the lead screw speed.

15.1.5 Significance

The overall purpose of doing this analysis was to ensure that the motor we chose to drive our lead screw mechanism was powerful enough to meet our performance goals. To do this, we determined the gear ratio required to drive the lead screw mechanism with that particular motor, as well as determined the speed the motor would have to spin to meet our goals. After the analysis was completed, it was decided that this motor was adequate to power the lead screw, therefore no changes were made to the design.

15.2 PRODUCT RISK ASSESSMENT

15.2.1 Risk Identification

We identified six potential risks inherent to our design that we would consider in the future design of this product, if given more time and resources. The table below shows the Risk Identification Table used to determine the severity of the identified risks.

What is the risk?	Describe the identified risk	How is risk currently managed?*	Comments/Concerns	Impact	Likelihood	Risk Calculation			Do you need to do anything else to reduce or control the risk?
						Impact	Likelihood	Risk Score	
Example: Serving food	Preparing and serving food to 100 people during event (food is not being prepared or served by vendor)	- Students are required to wash their hands before handling food. - On-site refrigerator for proper food storage. - Ensuring all equipment, dishware and utensils are clean and sanitary before use.	- Some people attending event may have food allergies. - Want to ensure food is cooked adequately.	Moderate	Low-Medium	3	2	6	- Print signage that warns of food allergens and place in front of food station. - Purchase thermometers to check the food temperature.
Lead Screw Pinch Point	If the user places their hand on the lead screw as it is turning, it may get pinched between the carousel and the threads of the lead screw	There is no risk management implementation currently in place.	Want to ensure that the product is safe to be used by inebriated individuals who may want to touch the moving parts of the mechanism.	Moderate	Low-Medium	3	2	6	Add a sticker on the base with a warning not to touch moving parts.
Bottles Breaking	While loading/unloading the bottles from the carousel, the bottles may fall and break.	Anticipated training for maintenance and cleaning.	Want to ensure that the product is safe to be loaded/unloaded by a trained personnel for cleaning and routine maintenance.	Mild	Low-Medium	2	2	4	Create an instruction manual.
Falling Off Bar	The machine could slide, fall, or tip off of the bar as it is being used.	The base is wide enough so that the machine is not inherently unsteady despite having a large amount of unbalanced moving mass.	The machine is heavy enough to potentially cause major property or bodily damage.	Significant	Low	4	1	4	Add an anchor to fix the machine to the bar to eliminate the risk.
Carousel Breaking Support	If the motor on the lead screw malfunctions, it could lift the carousel up to and against the top support. This could break the support or burn out the motor or other components.	There is no risk management implementation currently in place.	The motor malfunctioning could cause damage to the machine and lead to needing replacement parts.	Insignificant	Low	1	1	1	Add redundancies to the code and/or add a sensor to the top of the support.
User Grabbing Cup	If the user decides to grab the cup while the machine is still running, their hand may get pinched between the carousel valve and the cup.	There is no risk management implementation currently in place.	Want to ensure that the product is safe to be used by inebriated individuals who may want to touch the moving parts of the mechanism.	Mild	Medium	2	3	6	Add a sticker on the base with a warning not to touch moving parts.
Cup Spills	If the cup is not centered under the valve the carousel may tip the cup over and spill the liquid, which could cause a slip hazard.	The code is designed to have very little variability in orienting the cup.	Want to keep spillage and cleanup to a minimum, as well as ensure a safe environment.	Insignificant	Medium	1	3	3	Warn bartenders to watch for and immediately clean up any spills.

Figure 29: Risk identification template

In determining the risks of our project, we considered the different ways a consumer would interact with the machine and the ways the machine could, itself, malfunction. The least likely and least significant risk, the carousel breaking the support, would only occur if the motor malfunctions and continues to move past the highest point allowed by the code. If this would happen, it could break the top support of the machine, but it would likely not injure anyone in the premises. One risk with highest likelihood involves the cup spilling and saturating electronics. This would not have a huge impact on the projects, considering most of the circuitry is protected by the box. In addition, the spill could cause someone to slip and fall. The other most likely risk involves the user grabbing the cup before the machine has completed its motion. A user could potentially get hurt in this, but considering the slow moving lazy-susan with lack of sharp edges, we do not see this a catastrophic risk.

The medium impact risks are both fairly unlikely. A user could potentially reach their hand into touch the lead screw as it is rotating, and the screw could pinch the finger of the user. Since the machine is going to be used by potentially intoxicated patrons, this is a mid-level risk. The other mid-level risk is the bottles breaking while loading or unloading the carousel. An integral part of our project is ensuring the personnel maintaining the machine are trained in assembling and disassembling. This risk of bottles breaking is the same risk that would occur in a normal bar setting. The risk closest to catastrophic is the risk of the whole mixer falling off the bar. This could not only break the entire machine, but it could also hurt someone on

the way down. Since the machine is so heavy and the base is so big, it is pretty unlikely that this will happen.

15.2.2 Risk Heat Map

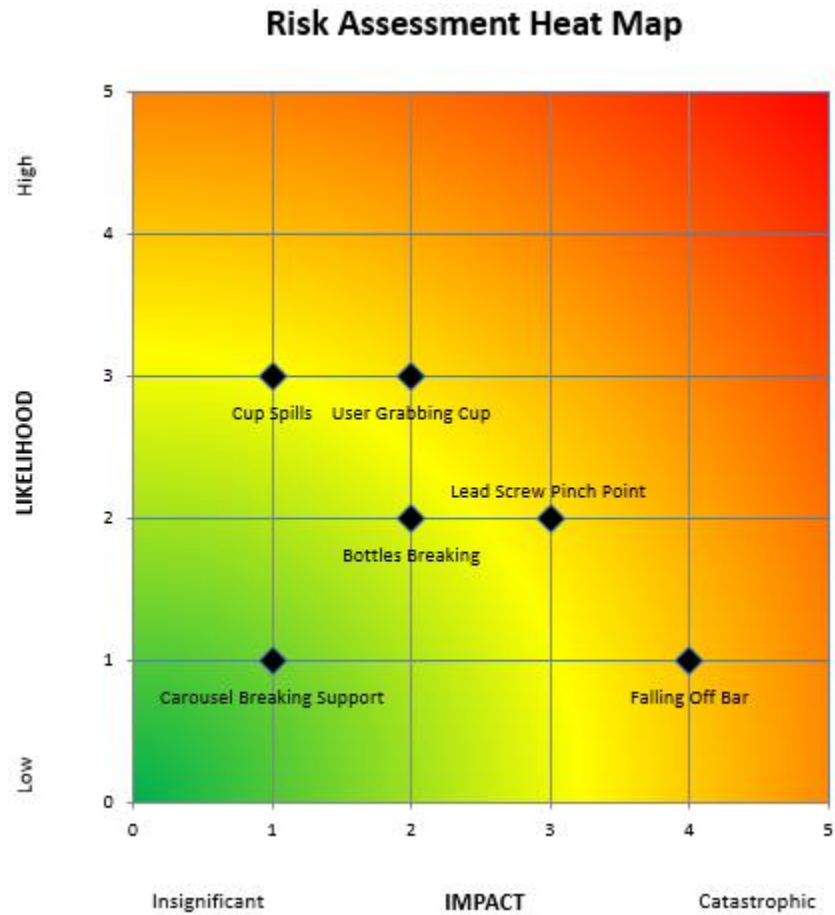

Figure 30: Risk Assessment Heat Map

15.2.3 Risk Prioritization

The risks that we would choose to prioritize over others would be the ones with higher likelihood of occurring with at medium risk; i.e. the user grabbing the cup before the machine has completed mixing the drink, the user grabbing at moving parts, the bottles breaking during loading and unloading, and the machine causing the cup to spill. Most of these risks can be addressed with stickers on the base warning users not to touch the internal parts of the machine or rigorous training for the bartenders. The next risk that we would address is the MIXoTRON falling off of the bar. This would be addressed simply by anchoring the machine to the bar.

16 DESIGN DOCUMENTATION

16.1 PERFORMANCE GOALS

There are five performance goals for this project that will determine the success of the project. These performance goals are as follows:

1. The MIXoTRON will make one mixed drink in less than 30 seconds.
2. The MIXoTRON will make 20 drinks before switching batteries.
3. The MIXoTRON will be able to be disassembled and reassembled in less than 5 minutes by trained personnel for basic cleaning and minor maintenance.
4. The MIXoTRON will be able to make 5 different cocktails.
5. The MIXoTRON will be able to make 8 drinks without manually centering.

16.2 WORKING PROTOTYPE DEMONSTRATION

16.2.1 Performance Evaluation

To evaluate the success of our project we either tested or analyzed each performance goal.

On average, it took the prototype one minute and thirty seconds to make one drink. This is three times as long as we had hoped for, therefore our prototype has failed performance goal one by our original standards. However, we also wanted to compare our prototype against the average bartender to see how our design compares. During research and customer interviews we found that it takes the average bartender roughly one minute to make a more complex cocktail than just a mixture of two ingredients. Thus, our prototype is still unsuccessful in comparison. There are a few ways we could speed up the device. First, we could redesign the gears on the lead screw so that the gear ratio is numerically closer to one. This would step down the torque, but would increase the speed of the lead screw. We could also use a lead screw with a steeper thread pitch, or simply buy a more powerful motor.

To analyze our second performance goal, we found the total current draw of each electrical element used to power the device. The total current draw of our prototype is roughly 1A (a breakdown of the calculations can be found below). Our prototype is currently powered by 8 AA batteries connected in series to provide a total voltage of 12V. We found a lifecycle chart of Procell AA batteries providing a constant current. Our prototype would follow the 1000mA curve designated in red on this chart, which corresponds to a service life of roughly 1 hour of continuous use. Knowing that our device can make one drink in 1.5 minutes, we estimate that the prototype can make 40 drinks before having to switch batteries.

Total Current Draw: ~942 mA -> Appx 1000 mA

- Lead Screw Motor: ~672 mA
- Turn Table Stepper: ~140 mA
- Arduino Uno: ~130 mA
- Motor Driver: ~ Negligible

Procell AA Battery Service Life: ~1hr

In 1 hour, the MIXoTRON can make:

$$\frac{60 \text{ minutes}}{1.5 \text{ min/drink}} = 40 \text{ drinks (continuously)}$$

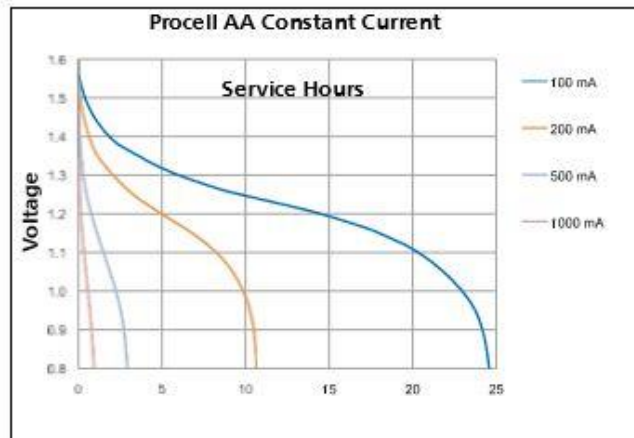

Figure 31: Total Current Draw and Battery Life Calculations [2]

To test the third performance goal, one member of the group was tasked with disassembling the prototype to the extent of basic cleaning and maintenance, and reassembling it again. This would be the kind of task that a bartender would have to perform if the device were at a bar. In total, this task took about one and a half minutes, which is 30% of the 5 minutes allotted.

We defined one mixed drink to be a mixture of two ingredients to analyze our fourth performance goal. While the carriage is designed to hold 6 bottles, we only tested with 4. Even still, using a permutation of 2 choices of 4 ingredients, we can make a total of 12 different recipes. If we further define one mixed drink to be comprised of exactly two different ingredients, we reduce our menu to only 8 drinks (calculations shown below). This is still greater than the 5 we expected.

Ingredient Capacity: 4

1 drink is comprised of 2 Ingredients

Total number of possible recipes:

$$\bullet \frac{4!}{(4-2)!} = 12 \text{ options}$$

$$\bullet \frac{4!}{(4-2)!} - 4 = 8 \text{ options}$$

Figure 32: Total Number of Recipes Calculation

Unfortunately, the fifth performance goal is automatically a failure. This goal was directed at keeping the error down when pre-programming drink recipes. We were planning on using light sensors to detect when

the cup was under the correct bottle. We expected a small amount of error in this process, and expected that the error would accumulate over time, and eventually need to be manually re-centered to keep the device in working condition. Since we do not have recipes pre-programmed, this goal is untestable.

Overall, we consider this project a qualified success. We have met or exceeded three of the five performance goals, and have plans to improve upon the two that failed.

16.2.2 Working Prototype – Video Link

Please follow the link below to view the Final Prototype Review video on YouTube:

<https://youtu.be/APT1XfQo7AQ>

16.2.3 Working Prototype – Additional Photos



Figure 33: Inner Circuitry of the MIXoTRON



Figure 34: The MIXoTRON in Operation



Figure 35: Disassembling the MIXoTRON



Figure 36: Volumetric Valve Dispensing Liquid

17 DISCUSSION

17.1 DESIGN FOR MANUFACTURING – PART REDESIGN FOR INJECTION MOLDING

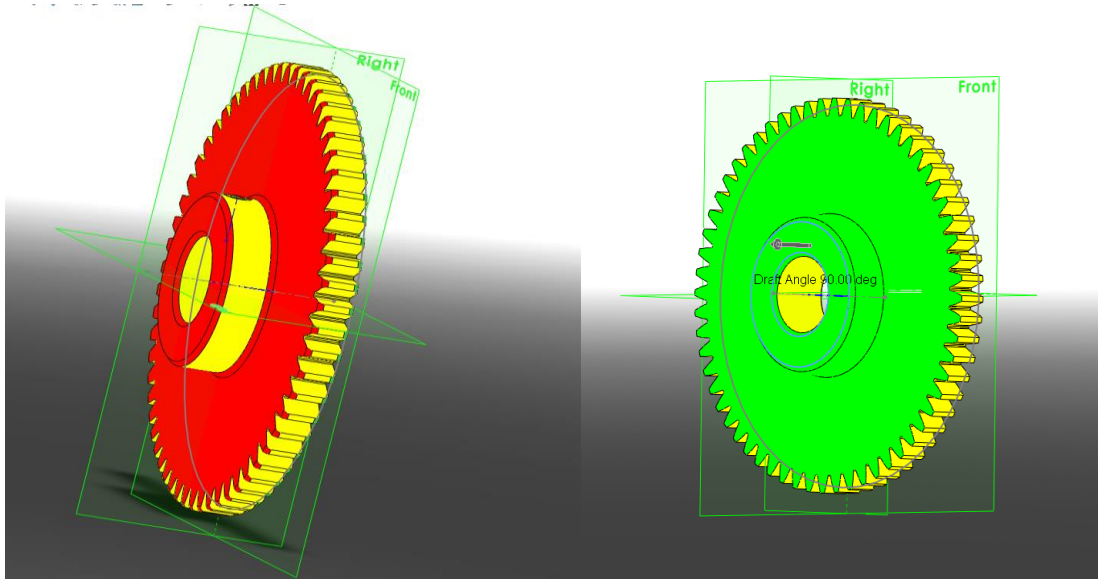

Figure 37: Before and after comparison of one of the lead screw gears chosen for draft analysis

Shown above is a before-and-after comparison of one of the power-screw gears chosen for draft analysis. The gears are some of the few parts which are possible to be injection molded. The picture above shows that as a 5 degree of draft, we will need higher draft for the left face.

17.1.1 Explanation of Design Changes

Taking the above results into account, we have decreased the dimensions of the left face linearly with its opposite face along the gear teeth. This will insure that the injection molding process will produce higher quality gears. The dimensional alterations were done on Solidworks along the single face. There are concerns about the position of the lock screw holes placement.

17.2 DESIGN FOR USABILITY – EFFECT OF IMPAIRMENTS ON USABILITY

17.2.1 Vision

A person who suffers from a visual impairment such as color blindness should not have any problem using our machine. The user interface does not require differentiating colors. A person suffering from presbyopia, though, may have trouble reading the small print of the drink labels. We could ensure that the font is large and clear, so the customer would be more likely able to read the menu. We could also add pictures of the drink or the ingredients in the drink which could make the choices clearer to the user. For a person who is legally blind, we could add the braille displays of each choice, which is a pretty common solution.

17.2.2 Hearing

One of our design decisions was to add a noise when the drink is completed so the user knows the drink is ready to take out of the holder. We could implement a light that goes off as well when the drink is finished. There are no other significant noises a user would need to interpret to use the machine

17.2.3 Physical

If a person has a physical handicap requiring a wheelchair, the machine may be too high to reach. This would mostly be up to the individual bars on where they would place the drink maker. There is not a lot of physical activity involved in using our machine, just pressing a button and removing the drink.

17.2.4 Language

Our menu used in our machine is completely in English. Similar to the menu suggested in the visual impairment section, the menu could include pictures of the final drink and the ingredients. We could also provide additional menus in other common languages that are available for the users to read.

7.2 OVERALL EXPERIENCE

7.2.1 Does your final project result align with the initial project description?

In basic principle our initial design and final product do align. But the process used to complete the various required actions (pouring, mixing, choosing drink liquids) all deviate to a degree from our first conceptualization of the device.

7.2.2 Was the project more or less difficult than you had expected?

The design presented several challenges that were not initially apparent during the planning phase of the project. These unplanned issues contributed to rapid, minor redesigns and drastically increased the required manufacturing time at every level.

7.2.3 In what ways do you wish your final prototype would have performed better?

The final design as well as middle stage iterations of the Drink Mixer were limited by requiring certain components. The need to have a volumetrically accurate drink necessitated the use of a specific proprietary valve. This valve's immutability forced a major redesign of the main assembly. We wish we could have been able to either alter the specifications of the valve or had access to more sophisticated components that could complete the same task.

7.2.4 Did your group miss any critical information when you evaluated concepts?

No, we had a strong grasp on the fundamental engineering concepts we would need to produce the final product. Nearly every issue which arose was due to poor manufacturing tools/components or inaccurate measurements when performing preliminary analysis.

7.2.5 Were there additional engineering analyses that could have helped guide your design?

A greater detailed descriptor of the volumetric valve would have allowed us to make a better-informed choice for what design path to take early on in the decision phase. During the early manufacturing phase several wooden pieces were destroyed by pressure from other components. Solidworks as available to us did not have the material properties of the specific type of wood loaded which limited how we could have planned ahead for such failures.

7.2.6 How did you identify your most relevant codes and standards and how they influence revision of the design?

After meeting with a representative of the Washington University Engineering library we were directed to several resources for codes and standards of food dispensing/vending machinery. These resources helped push us towards streamlining the liquid holding components to help minimize the expense of manufacturing.

7.2.7 What ethical considerations (from the Engineering Ethics and Design for Environment seminar) are relevant to your device? How could these considerations be addressed?

The main design choice we made based on ethical concerns were concerned with using recycled materials. Nearly every component used in the MIXoTRON was taken from prior existing assemblies. The only exceptions where the rotation plexiglass plate, gears, and some fasteners.

7.2.8 On which part(s) of the design process should your group have spent more time? Which parts required less time?

The configuring of our physical frame and motor required more time than expected. Conversely the code writing to control the drinks production required less time to solve, as well as less time than was expected by a large margin.

7.2.9 Was there a task on your Gantt chart that was much harder than expected? Were there any that were much easier?

The drive screw and turn table both required significantly more work than initially expected. We had anticipated needing only a week to meet minimum movement requirements with the remaining weeks to be used enhancing the prototypes aesthetic qualities and movement speed. Most of this time instead was consumed getting the model to the acceptable level.

7.2.10 Was there a component of your prototype that was significantly easier or harder to make/assemble than you expected?

Due to limitations in the facilities made available to use for manufacturing, the electronics box and turn table where harder to shape than what would have seemed reasonable beforehand. The provided cutting equipment where generically less accurate than what was needed, and this great care had to be taken during the shaping process.

7.2.11 If your budget were increased to 10x its original amount, would your approach have changed? If so, in what specific ways?

Yes, several ideas were scrapped due to cost of producing. The largest divergence would be in using an electronic sensor to measure the volume of dispensed liquids. The specific method of volume measuring used in our final design greatly restricted other aspects of the drink mixers design.

7.2.12 If you were able to take the course again with the same project and group, what would you have done differently the second time around?

If we were to redo this project the first and major change we would make would be the breath of actions we wanted the Mixer to achieve. Throughout the entire semester we were forced to shave and refine exactly what we expected from the finish produce based on limited resources and time. If we started with a simpler goal the final product might have had greater refinement.

7.2.13 Were your team member's skills complementary?

At least one member had background experience with every aspect of the shaping and assembling process be it woodworking, metal working, coding, or servo-sensors.

7.2.14 Was any needed skill missing from the group?

As stated above, at least one member was proficient at every stage. What we could have used was individually or as a group was deeper experience with this specific kind of machine. If we had been more experienced than several obvious, in hindsight, errors could have been avoided.

7.2.15 Has the project enhanced your design skills?

Yes, we have all gained in-depth experience with the various stages of product design, and more importantly, manufacturing. Beyond the simple skills of machining and analysis we were also forced to become more skilled in servo-programing.

7.2.16 Would you now feel more comfortable accepting a design project assignment at a job?

Yes, we would.

7.2.17 Are there projects you would attempt now that you would not have attempted before?

As a group, we feel that we will now be able to take on projects with more confidence and more of a directive to make decisions on our own. In many

8 APPENDIX A - PARTS LIST

	Part	Source Link	Supplier Part Number	Color, TPI, other part IDs	Unit price	Tax (\$0.00 if tax exemption applied)	Shipping	Quantity	Total price
1	Final Touch® Upside Down Liquor Dispenser - 6 Bottle	BarProducts	NA	Silver	\$44.95	\$0.00	\$11.30	1	\$56.25
2	Thrust Needle Roller Bearing	McMaster-Carr	5909K31	1/2" shaft diameter	\$3.11	\$0.00	\$0.00	1	\$3.11
3	Washer for Thrust Bearing	McMaster-Carr	5909K44	1/2" shaft diameter	\$1.02	\$0.00	\$0.00	2	\$2.04
4	Turntable	McMaster-Carr	6031K16	Unlubricated - 3" square	\$2.18	\$0.00	\$0.00	1	\$2.18
5	Threaded Rod	McMaster-Carr	99065A135	B16 Med. Strength 1/2" diameter, 3' long	\$14.54	\$0.00	\$0.00	1	\$14.54
6	Corner Braces	Lowes	809427	1" galvanized steel	\$1.52	\$0.15	\$0.00	4	\$6.63
7	Brad Nails	Lowes	58179	16-Gauge 1.5-in Bright Steel Wire Brad	\$1.30	\$0.13	\$0.00	1	\$1.43
8	12V Battery Pack	Amazon	NA	Co-Rode 8AA Battery Pack	\$8.00	\$0.17	\$0.00	1	\$8.17
9	Motor Driver	MicroCenter	576322	LEO SALES MOTOR DRIVER FOR ARDUINO	\$9.99	\$1.01	\$0.00	1	\$11.00
10	Jumper Wires	MicroCenter	787311	LEO SALES Jumper Wires MF	\$14.99	\$1.51	\$0.00	1	\$16.50
11	Arduino Mega	MicroCenter	422238	Keyes Mega 2560 Board	\$9.99	\$1.01	\$0.00	1	\$11.00
12	Keypad	MicroCenter	253113	Velleman 3x4 Membrane Keypad	\$4.99	\$0.50	\$0.00	1	\$5.49
13	Plexiglass	Jolley Basement	NA	.22"x18"x24"	\$0.00	\$0.00	\$0.00	1	\$0.00
14	Wood	Jolley Basement	NA	wood brown	\$0.00	\$0.00	\$0.00		\$0.00
15	Brackets	Jolley Basement	NA		\$0.00	\$0.00	\$0.00		\$0.00
16	Wires	Jolley Basement	NA	multi colored and lengthed	\$0.00	\$0.00	\$0.00		\$0.00
17	Arduino Uno	Christina Bell	NA	full project kit	\$0.00	\$0.00	\$0.00	1	\$0.00
18	Nails/Screws/Fasteners	Jolley Basement	NA	assorted finishes and sizes	\$0.00	\$0.00	\$0.00		\$0.00
Total:									\$138.41

Figure 38: Parts List

9 APPENDIX B - CAD MODELS

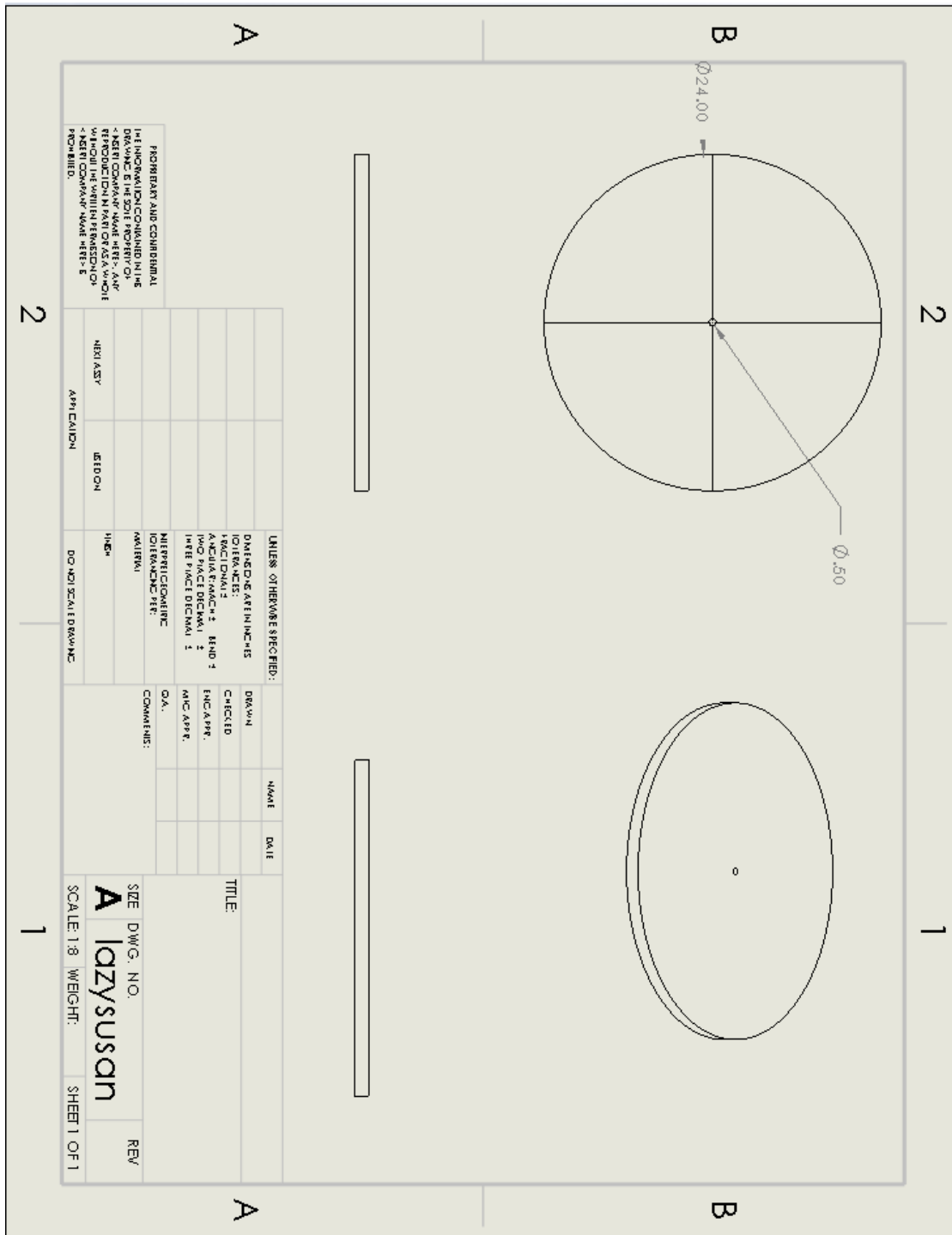

Figure 39: CAD Drawing of Lazy Susan

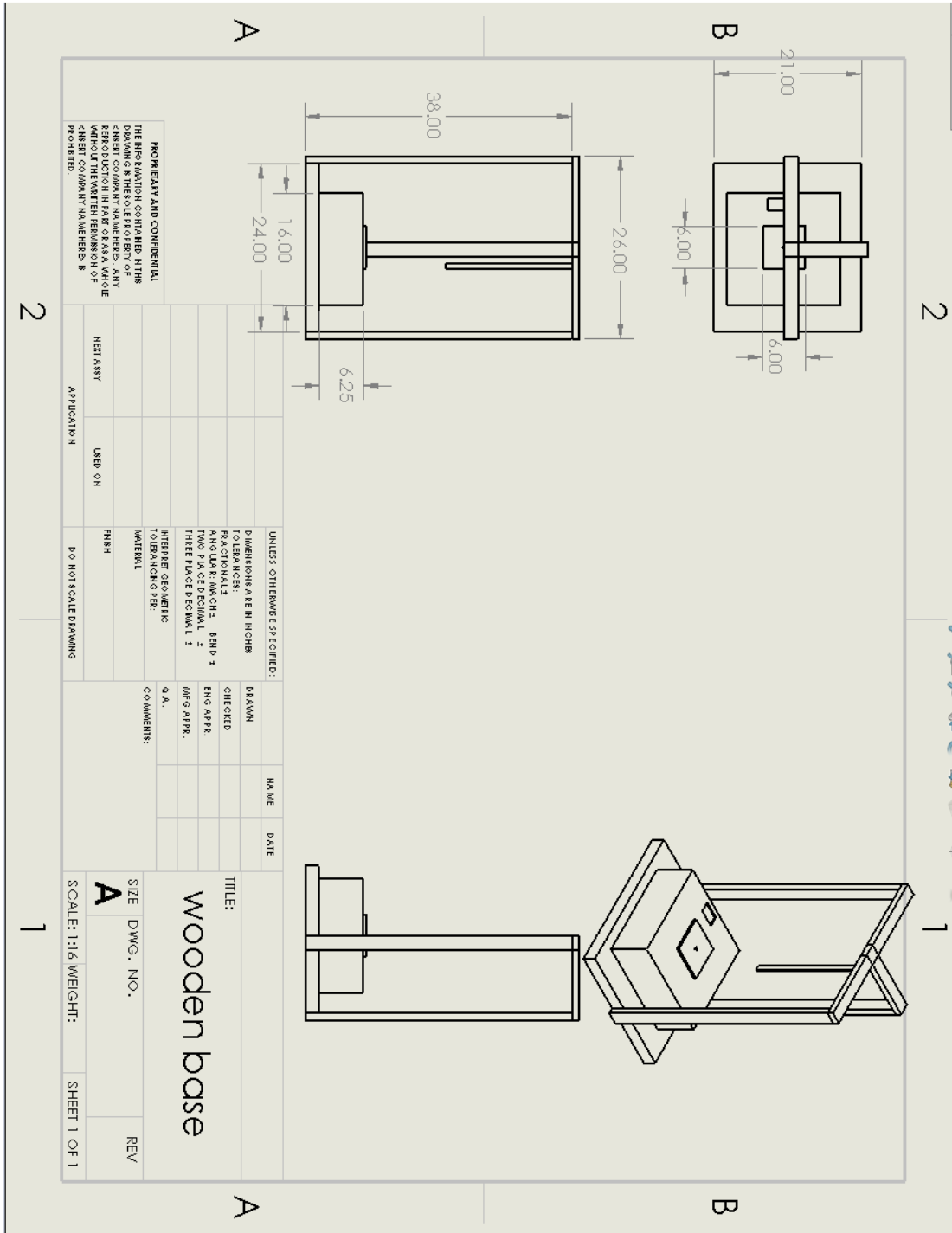

Figure 40: CAD Drawing of Wooden Base

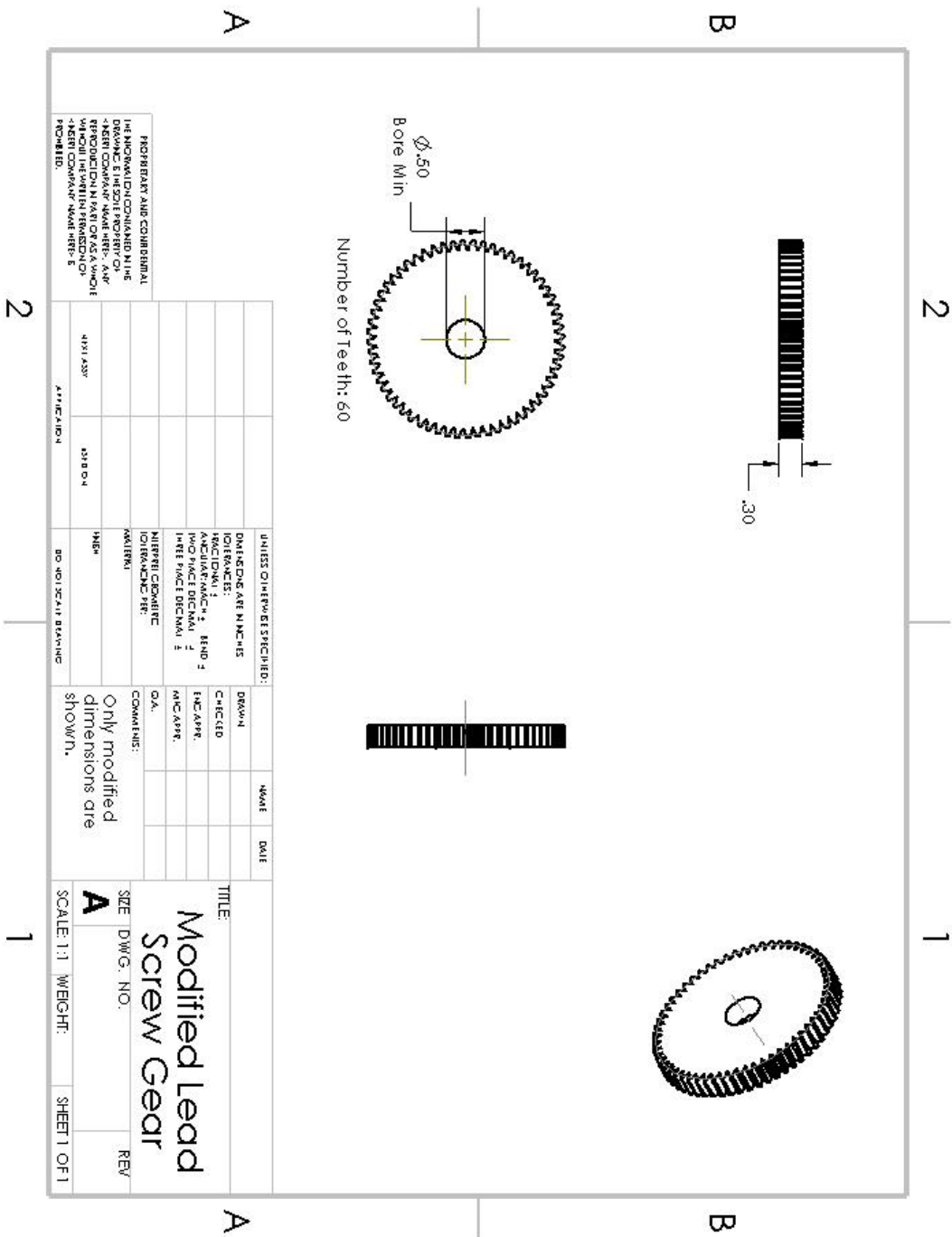

Figure 41: Lead Screw Gear, Modified from McMaster Part 6832K6600

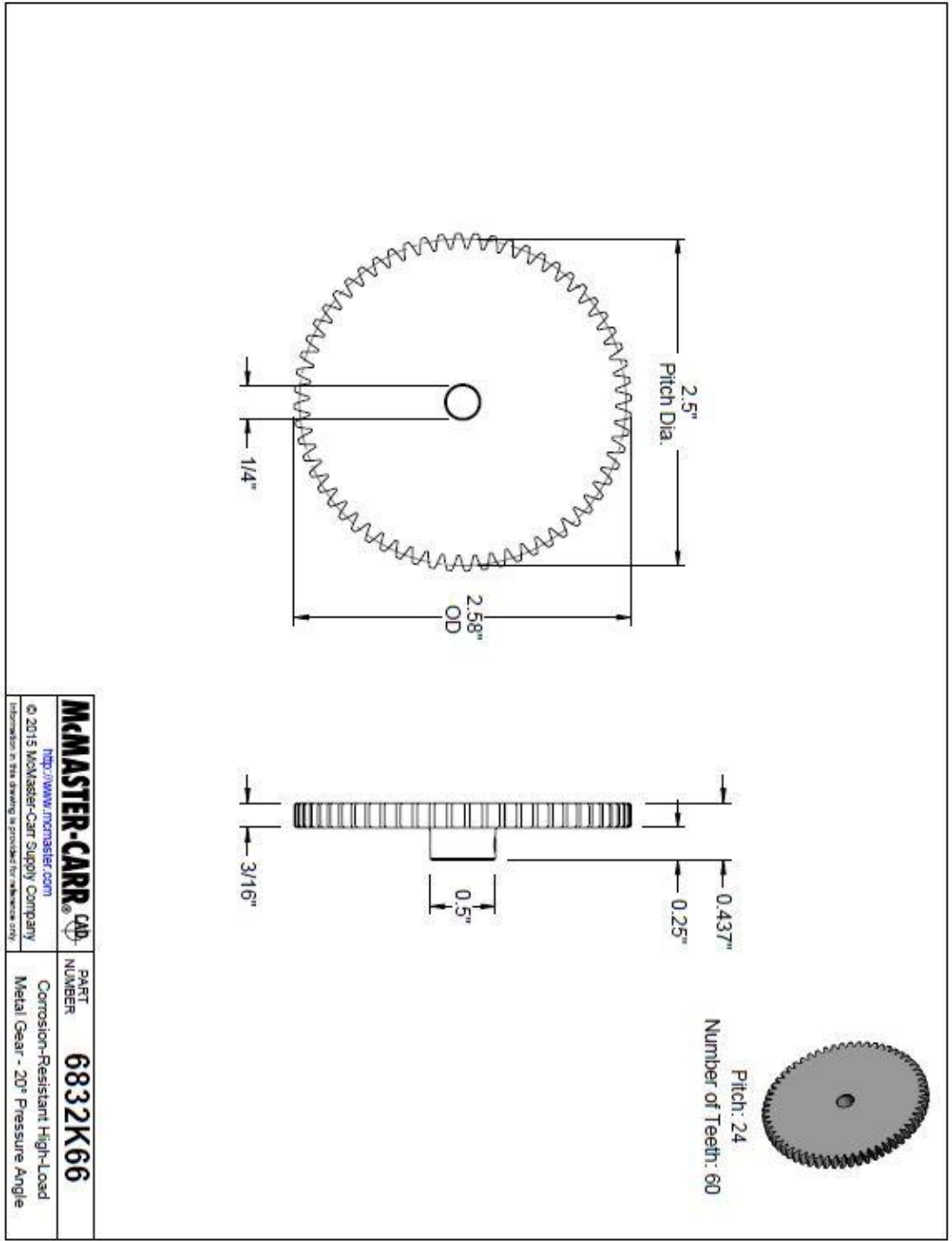

Figure 42: McMaster Gear Modified for Lead Screw

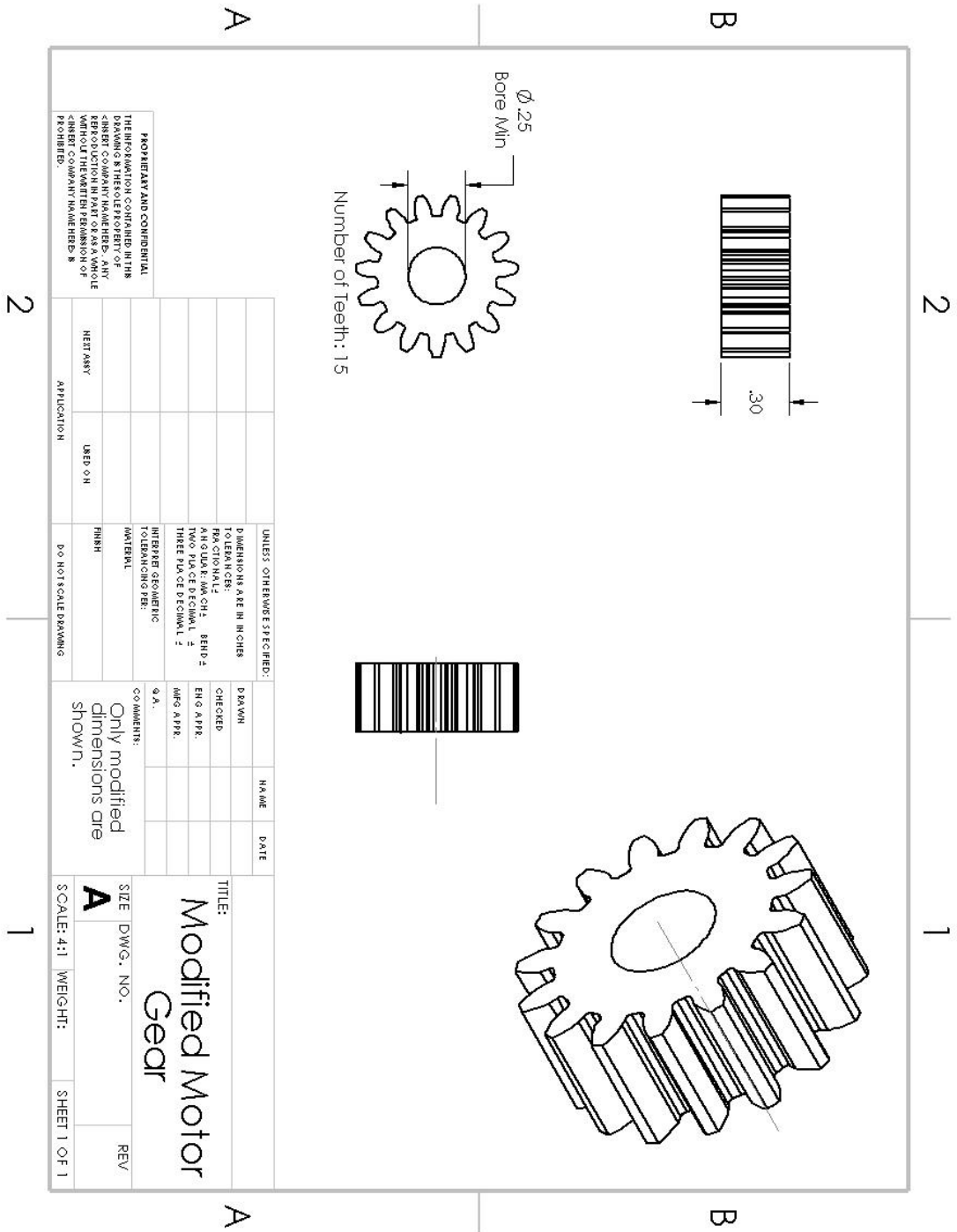

Figure 43: Motor Gear, Modified from McMaster Part 6832K6590

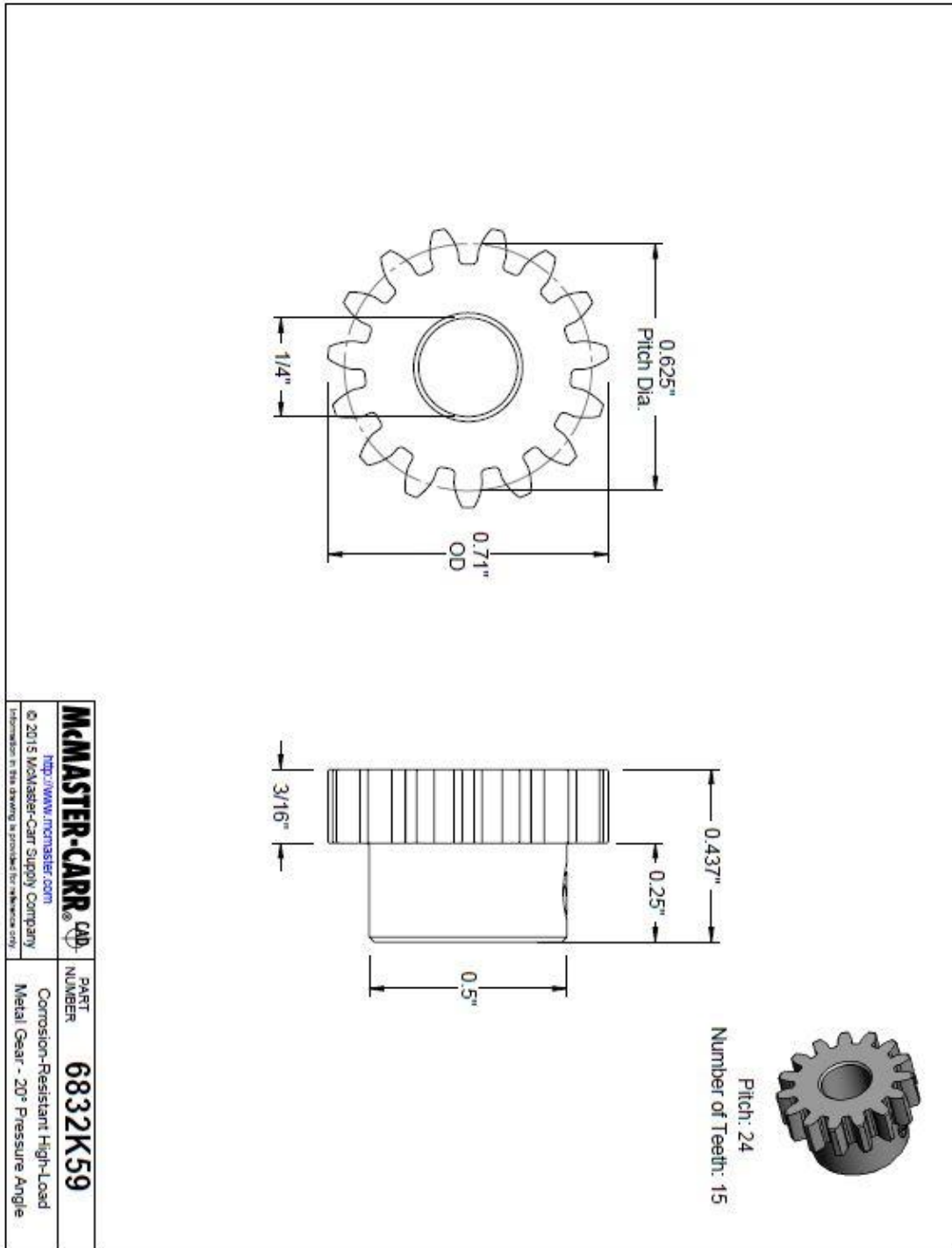

Figure 44: McMaster Gear Modified for Motor Gear

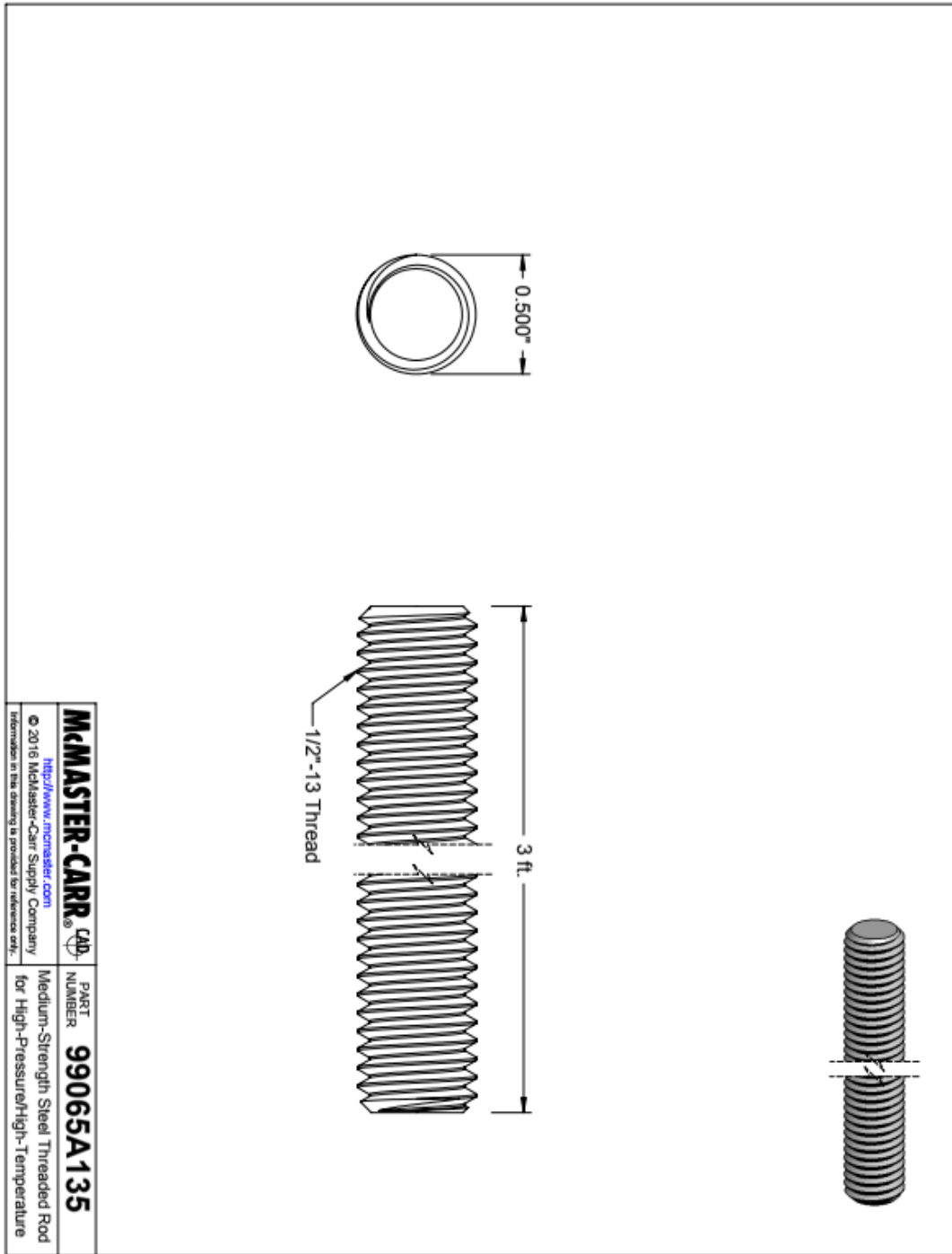

Figure 45: CAD Drawing of Threaded Rod, Received from McMaster

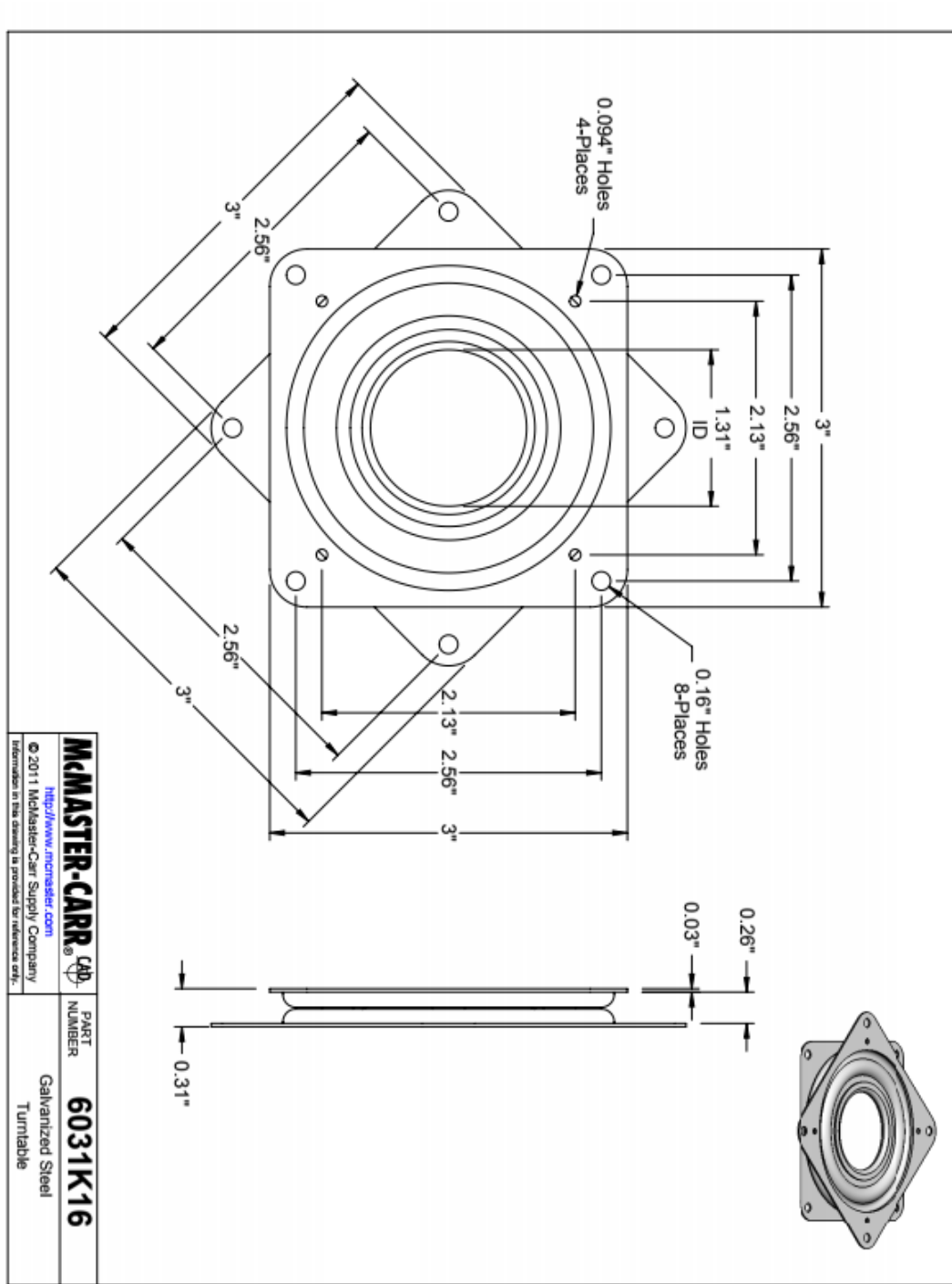

Figure 46: CAD Drawing of Turntable, Received from McMaster

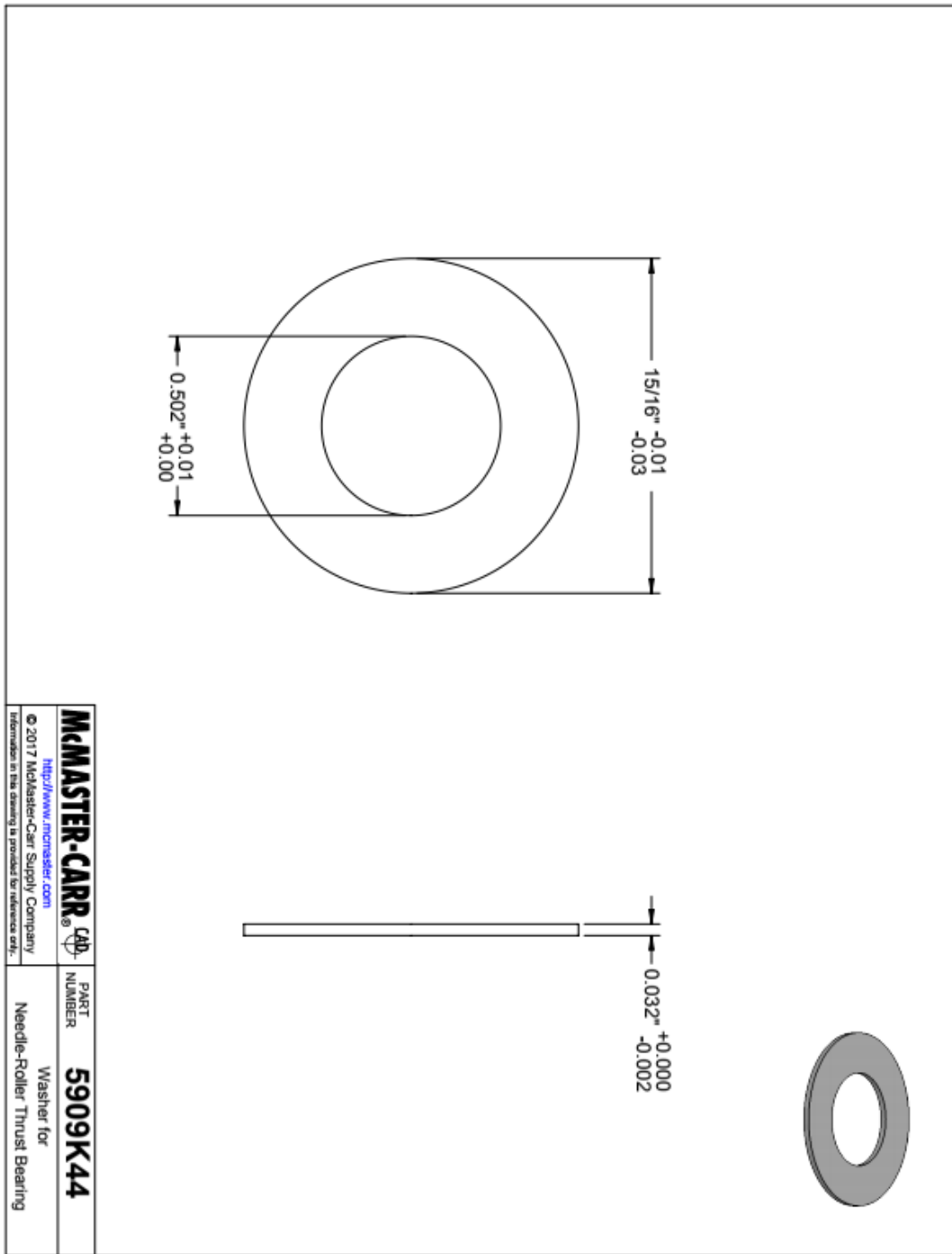

Figure 47: CAD Drawing of Thrust Bearing, Received from McMaster

10 ANNOTATED BIBLIOGRAPHY

- [1] R. L. Norton, Machine Design, an Integrated Approach, 4th ed., Worcester, MA: Prentice Hall, 2011.
- [2] "Duracell Technical Library," Duracell, 2016. [Online]. Available:
<https://d2ei442zrkqy2u.cloudfront.net/wp-content/uploads/2016/03/PC15US12141.pdf>.