

Washington University in St. Louis

## Washington University Open Scholarship

---

Mechanical Engineering Design Project Class

Mechanical Engineering & Materials Science

---

Fall 2015

### **MEMS 411 Design Report - Modular "Do-It-All" Drone**

Nicholas Okafor

*Washington University in St Louis*

Jordi Turner

*Washington University in St Louis*

David Brablec

*Washington University in St Louis*

Ike Witte

*Washington University in St Louis*

Follow this and additional works at: <https://openscholarship.wustl.edu/mems411>



Part of the [Mechanical Engineering Commons](#)

---

#### **Recommended Citation**

Okafor, Nicholas; Turner, Jordi; Brablec, David; and Witte, Ike, "MEMS 411 Design Report - Modular "Do-It-All" Drone" (2015). *Mechanical Engineering Design Project Class*. 32.

<https://openscholarship.wustl.edu/mems411/32>

This Final Report is brought to you for free and open access by the Mechanical Engineering & Materials Science at Washington University Open Scholarship. It has been accepted for inclusion in Mechanical Engineering Design Project Class by an authorized administrator of Washington University Open Scholarship. For more information, please contact [digital@wumail.wustl.edu](mailto:digital@wumail.wustl.edu).

---

# MEMS 411 Final Report

## Modular “Do-It-All” Drone

David Brablec, Nick Okafor, Jordi Turner, Isaac Witte



## Table of Contents

List of Figures

List of Tables

- 1 Introduction
  - 1.1 Project problem statement
  - 1.2 List of team members
- 2 Background Information Study
  - 2.1 Design brief
  - 2.2 Relevant background information
- 3 Concept Design and Specification
  - 3.1 User needs, metrics, and quantified needs equations.
    - 3.1.1 Record of the user needs interview
    - 3.1.2 List of identified metrics
    - 3.1.3 Table/list of quantified needs equations
  - 3.2 Four concept drawings
  - 3.3 A concept selection process
    - 3.3.1 Concept scoring
    - 3.3.2 Preliminary analysis of each concept’s physical feasibility
    - 3.3.3 Final summary
  - 3.4 Proposed performance measures for the design
- 4 Embodiment and fabrication plan
  - 4.1 Embodiment drawing
  - 4.2 Parts List
  - 4.3 Draft detail drawings for each manufactured part
  - 4.4 Description of the design rationale for the choice/size/shape of each part
- 5 Engineering analysis

- 5.1 Engineering analysis proposal
  - 5.1.1 A form, signed by your section instructor
- 5.2 Engineering analysis results
  - 5.2.1 Motivation
  - 5.2.2 Summary statement of analysis done
  - 5.2.3 Methodology
  - 5.2.4 Results
  - 5.2.5 Significance
  - 5.2.6 Summary of code and standards and their influence
- 6 Working prototype
  - 6.1 A preliminary demonstration of the working prototype
  - 6.2 Prototype photos
  - 6.3 A short videoclip that shows the final prototype performing
- 7 Design documentation
  - 7.1 Final Drawings and Documentation
    - 7.1.1 A set of engineering drawings that includes all CAD model files and all drawings derived from CAD models.
  - 7.2 Final Presentation
    - 7.2.1 A link to a video clip of final presentation
  - 7.3 Teardown
- 8 Discussion
  - 8.1 Using the final prototype produced to obtain values for metrics, evaluate the quantified needs equations for the design. How well were the needs met? Discuss the result.
  - 8.2 Discuss any significant parts sourcing issues? Did it make sense to scrounge parts? Did any vendor have an unreasonably long part delivery time? What would be your recommendations for future projects?
  - 8.3 Discuss the overall experience:
    - 8.3.1 Was the project more of less difficult than you had expected?
    - 8.3.2 Does your final project result align with the project description?

- 8.3.3 Did your team function well as a group?
- 8.3.4 Were your team member’s skills complementary?
- 8.3.5 Did your team share the workload equally?
- 8.3.6 Was any needed skill missing from the group?
- 8.3.7 Did you have to consult with your customer during the process, or did you work to the original design brief?
- 8.3.8 Did the design brief (as provided by the customer) seem to change during the process?
- 8.3.9 Has the project enhanced your design skills?
- 8.3.10 Would you now feel more comfortable accepting a design project assignment at a job?
- 8.3.11 Are there projects that you would attempt now that you would not attempt before?

9 Appendix A - Parts List

10 Appendix B - Bill of Materials

11 Appendix C - CAD Models

12 Annotated Bibliography

## List of Figures

[Figure 1: #1\) Custom “X” Attachment and USB Connection](#)

[Figure 2: #2\) Electromagnet and Wi-Fi](#)

[Figure 3: #3\) Buckle, Dock, and USB Connection](#)

[Figure 4: #4\) Span-On and USB Connection](#)

[Figure 5: User Needs Metric Table](#)

[Figure 6: Embodiment Drawing](#)

[Figure 7: Electronics Box](#)

[Figure 8: Attachment Buckle](#)

[Figure 9: Attachment with Flashlight Accessory](#)

[Figure 10: Attachment with Hook Accessory](#)

[Figure 11: Attachment Platform](#)

[Figure 12: Analysis Tasks Agreement](#)

[Figure 13: Front View of Entire System – Drone and Attachment Box](#)

[Figure 14: Inside View of Electronics in Attachment Box](#)

[Figure 15: Three Possible Attachments – Camera, Hook, Flashlight](#)

[Figure 16: Attachment Mechanism on the Attachment – Buckle and USB shown](#)

[Figure 17: Close Up of how Attachment Box and Attachment Should Be Attached](#)

[Figure 18: Attachment Box and Attachment Shown Attached](#)

[Figure 19: Teardown Agreement](#)

[Figure 20: Electronics Box](#)

[Figure 21: Attachment Buckle](#)

[Figure 22: Attachment with Flashlight Accessory](#)

[Figure 23: Attachment with Hook Accessory](#)

[Figure 24: Attachment Platform](#)

## List of Tables

[Table 1: Critical Questions, customer statements and interpreted needs Table](#)

[Table 2: Needs Importance value table](#)

[Table 3: List of identified needs and metrics](#)

[Table 4: Quantified Needs Equations](#)

[Table 5: Parts list with costs and quantities](#)

[Table 7: Detailed parts list](#)

[Table 8: Bill of materials](#)

## 1 Introduction

### 1.1 Project problem statement

The main objective of this senior design project is to design and build a capability that allows different attachments (i.e. camera, flashlight, speakers, hook) to be attached and detached electromechanically from a drone. The main challenge in this project was our cost constraints. Weight is one of the most important constraints in aerial vehicles, and with a small budget, it was very challenging to find a powerful drone and manufacture light and durable parts. The modular system involved two general components: a drone retrofit and the attachments. The drone needed to be retrofitted to house additional electronics (i.e. Arduino, remote control sensor, USB port) and a mechanical attachment mechanism. The attachments complemented the attachment mechanism on the drone retrofit, and some contained complementary electronics (i.e. USB connector). The attachments needed to be able to be attached and detached by a single person, and the design needed to be simple enough that it could be automated. Our reach goal was to design a port that allowed attachments to be attached and detached autonomously, but we were focused on primarily designing modularity. We were not able to get to constructing our autonomous port, but we were successfully able to meet all of our primary goals, key design metrics and user needs.

### 1.2 List of team members

Drone IV – Modular “Do-It-All” Drone:

David Brablec, Nick Okafor, Jordi Turner, Isaac Witte

## 2 Background Information Study

### 2.1 Design brief

The main objective of this senior design project is to design and build a capability that allows different attachments (i.e. camera, flashlight, speakers, hook) to be attached and detached electromechanically from a drone.

### 2.2 Relevant background information

There were no existing devices that provided the same functionality as our project, which made this a very exciting endeavor. The only drones with modular capabilities involved interchangeable camera lenses. Because there are many websites with manuals on the construction of drones and



open-source software for drone capabilities, we included the most relevant sources; these sources are listed and described below.

The DJI Zenmuse X5 is a photography drone that has an interchangeable camera lens capability. The drone camera is priced at \$2199, so this capability is extremely valuable in the market. The drone can be purchased on numerous consumer retail websites and the DJI website store:

[http://store.dji.com/product/zenmuse-x5?from=buy\\_now](http://store.dji.com/product/zenmuse-x5?from=buy_now)

ArduPilot and Dronecode provide open-source hardware and software for drones. The websites can be accessed at <http://ardupilot.com/> and <https://www.dronecode.org/>

There is a patent (US 8989922 B2) that discusses “Modular drone and methods for use.” While the patent seems similar, it is solely about a custom design of a drone that includes a navigation unit, RFID, and a Wi-Fi Transmitter. All of these capabilities would make for great attachments in a completely modular drone. <http://www.google.com/patents/US8989922>

When looking for attachment capabilities, the most applicable patent we found was US 6154935 A. The patent was for “Quick Release Buckle for Use on Backpacks and the Like.” Our attachment mechanism was fairly similar to this capability, but constructed in a separate way.

<http://www.google.com/patents/US6154935>

### 3 Concept Design and Specification

#### 3.1 User needs, metrics, and quantified needs equations.

##### 3.1.1 Record of the user needs interview

Table 1: Critical Questions, customer statements and interpreted needs Table

Questions	Customer Statement	Interpreted Need	Importance
How heavy or light do you want the device?	The lighter the better.	Weight	1
How durable do you want the device?	Durable enough to sustain some shock from falling from a small height.	Durability	3
What are the idea	Between a Frisbee	Width	2

dimensions for the drone?	and a meter diameter	Height	3
How would you like to operate the drone?	Remote control with video screen	Remote Design	4
Any energy source specifications?	Battery, possibly with solar panels?	Battery Life	2
Any cost restrictions for the drone?	\$500	Cost	1
What material considerations are present?	Drone to salvage, 3d printing costs, accessory costs	Salvaged Drone Cost Accessories Cost 3D Material Cost	(Part of Cost)
What other capabilities would you like?	Camera, speaker, carrier, dropper, holder	Functionalities	2
Can the Drone change its accessories by itself?	Yes	Accessory De/Attachment	1

Table 2: Needs Importance value table

Need Number	Need	Importance
1	Drone is light enough to fulfill its aerial functions	1
2	Drone is somewhat shock-resistant	3
3	Drone is between 25 and 100 cm in diameter	2
4	Drone is less than 25 cm tall	3
5	Drone lasts more than 5 minutes	4

6	Drone cost less than \$500	1
7	Drone has at least 3 functions	2
8	Drone can attach/detach accessories	1
9	Drone has a long battery duration	1

### 3.1.2 List of identified metrics

Table 3: List of identified needs and metrics

Metric Number	Associated Needs	Metric	Units	Min Value	Max Value
1	1,2,4	Height	cm	10	30
2	1,2,3	Diameter	cm	25	100
3	1,2,3,4	Structural Strength	cm (height dropped)	0	150
4	7	Salvaged Drone Cost	Dollars	50	200
5	3,4,7	3D Printed Frame Cost	Dollars	5	40
6	7,8	Accessories Cost	Dollars	20	200
7	7,8	Number of Functions	Integer	0	3
8	8,9	Can attach/detach accessories	Binary	0	1
9	1,6	Battery Duration	Integer	1	10

### 3.1.3 Table/list of quantified needs equations

Table 4: Quantified Needs Equations

Need#	Need	Metric									Need Happiness	Importance Weight (all entries should add up to 1)	Total Happiness Value	Need Happiness	Importance Weight (all entries should add up to 1)	Total Happiness Value	Need Happiness	Importance Weight (all entries should add up to 1)	Total Happiness Value	Need Happiness	Importance Weight (all entries should add up to 1)	Total Happiness Value	Need Happiness	Importance Weight (all entries should add up to 1)	Total Happiness Value
		Height	Diameter	Structural Strength	Salvaged Drone Cost	3D Frame Cost	Accessories Cost	# of Functions	Self-deattachable	Battery Duration															
1	Drone is light enough to fulfill aerial functions	0.25	0.3	0.1							0.35	0.5408333	0.15	0.081125	0.608333333	0.15	0.09125	0.7108333	0.15	0.106625	0.763333333	0.15	0.1145		
2	Drone is somewhat shock-resistant	0.25	0.25	0.5								0.5625	0.1	0.05625	0.658333333	0.1	0.0658333	0.7541667	0.1	0.0754167	0.75	0.1	0.075		
3	Drone is between 25 and 100 cm in diameter		0.5	0.3		0.2						0.572381	0.15	0.0858571	0.639047619	0.15	0.0958571	0.7057143	0.15	0.1058571	0.572380952	0.15	0.0858571		
4	Drone is less than 25 cm tall	0.5		0.3		0.2						0.4307143	0.1	0.0430714	0.555714286	0.1	0.0555714	0.6807143	0.1	0.0680714	0.805714286	0.1	0.0805714		
5	Drone lasts more than 5 minutes									1		0.7	0.05	0.035	0.6	0.05	0.03	0.6	0.05	0.03	0.8	0.05	0.04		
6	Drone costs less than \$500				0.4	0.2	0.3					0.3857143	0.2	0.0771429	0.302380952	0.2	0.0604762	0.4357143	0.2	0.0871429	0.435714286	0.2	0.0871429		
7	Drone has at least 3 functions						0.45	0.45	0.1			0.8	0.15	0.12	0.875	0.15	0.13125	0.875	0.15	0.13125	0.875	0.15	0.13125		
8	Drone can attach/deattach accessories								1			1	0.2	0.2	1	0.2	0.2	1	0.2	0.2	1	0.2	0.2		
Units		cm	cm	cm	\$	\$	\$	n/a	Binary	min		Total Happiness	0.6984464	Total Happiness	0.7302381	Total Happiness	0.8043631	Total Happiness	0.8143214						
Best Value		10	25	150	50	5	20	3	1	10															
Worst Value		80	100	0	200	40	200	0	0	0			1												
Actual Value		25	60	110	150	25	100	3	1	7															
Normalized Metric Happiness		0.25	0.5333333	0.7333333	0.3333333	0.4285714	0.5555556	1	1	0.7															
Actual Value		20	50	110	200	25	70	3	1	6															
Normalized Metric Happiness		0.5	0.6666667	0.7333333	0	0.4285714	0.7222222	1	1	0.8															
Actual Value		15	40	110	150	25	70	3	1	9															
Normalized Metric Happiness		0.75	0.8	0.7333333	0.3333333	0.4285714	0.7222222	1	1	0.6															
Actual Value		10	60	110	150	25	70	3	1	8															
Normalized Metric Happiness		1	0.5333333	0.7333333	0.3333333	0.4285714	0.7222222	1	1	0.8															

### 3.2 Four concept drawings

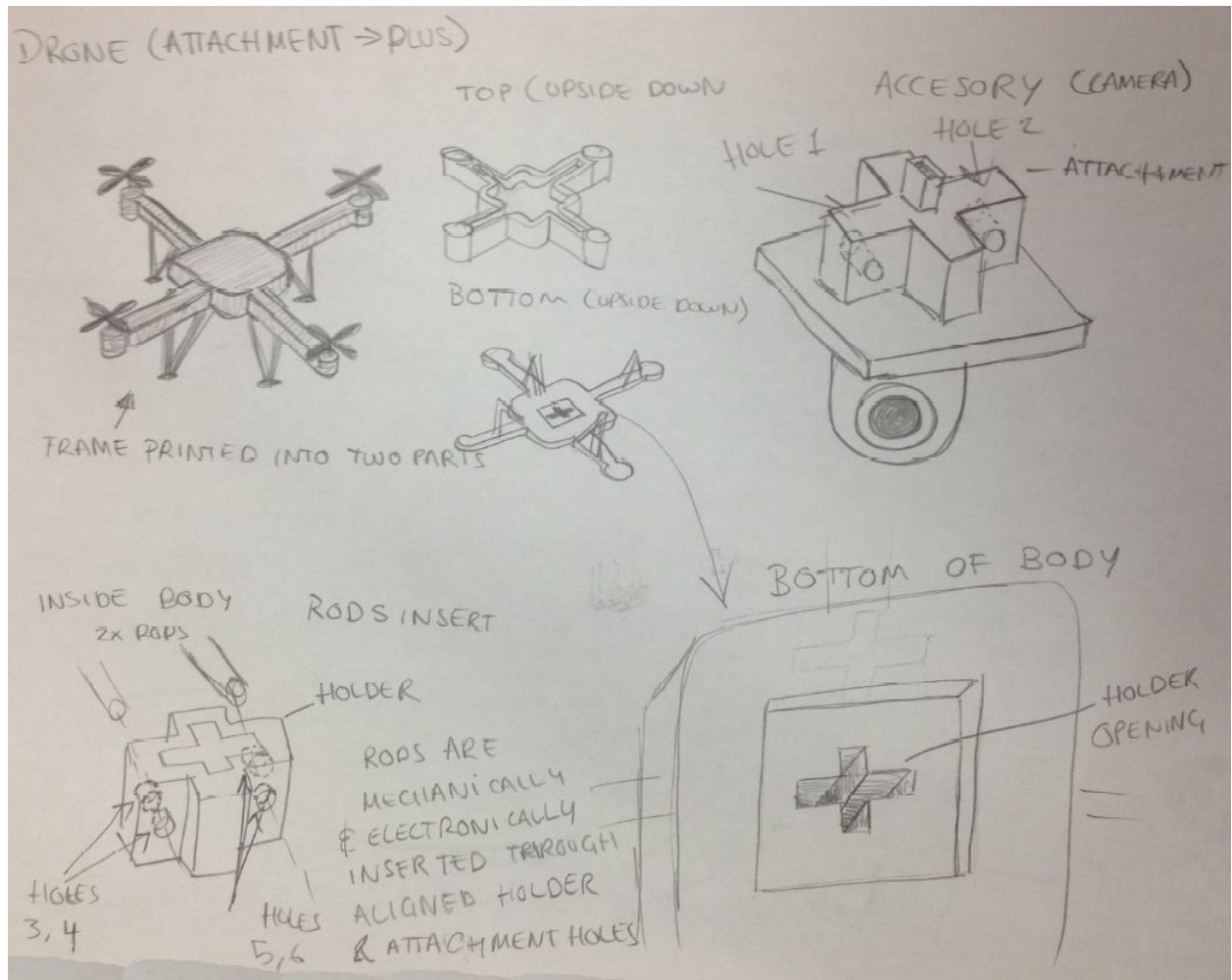

Figure 1: #1) Custom "X" Attachment and USB Connection

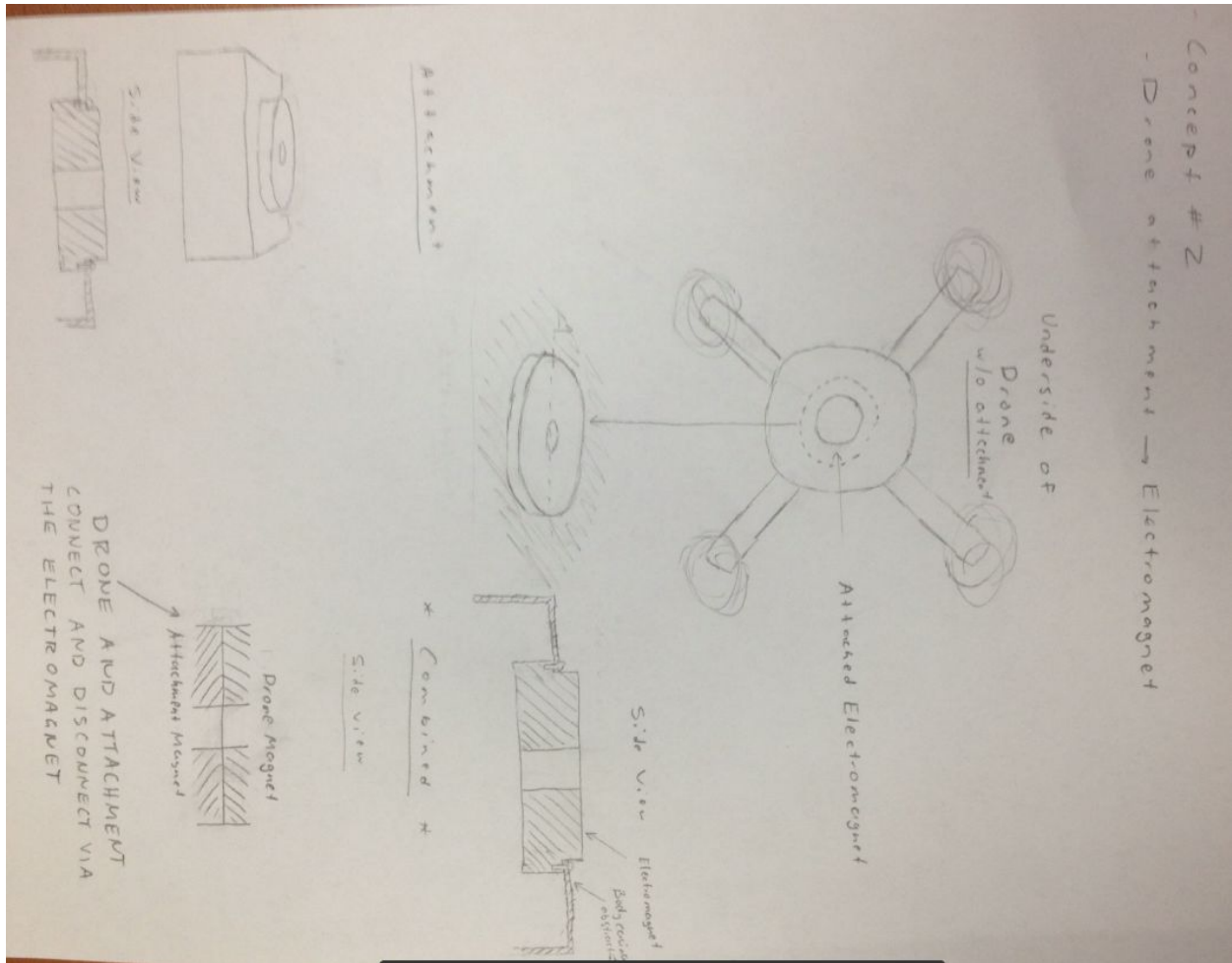

Figure 2: #2) Electromagnet and Wi-Fi

# Concept Sketch | DRONE

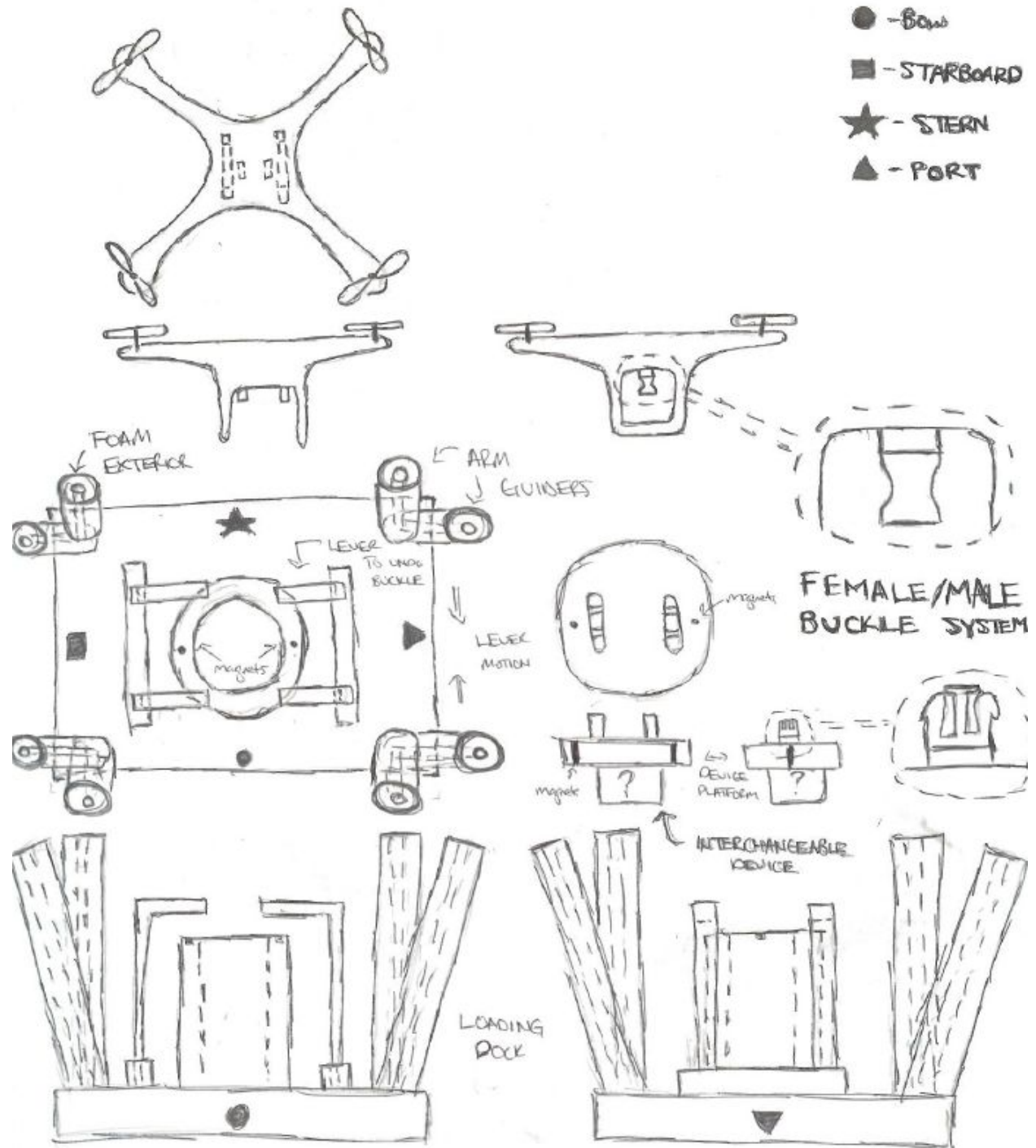

Figure 3: #3) Buckle, Dock, and USB Connection

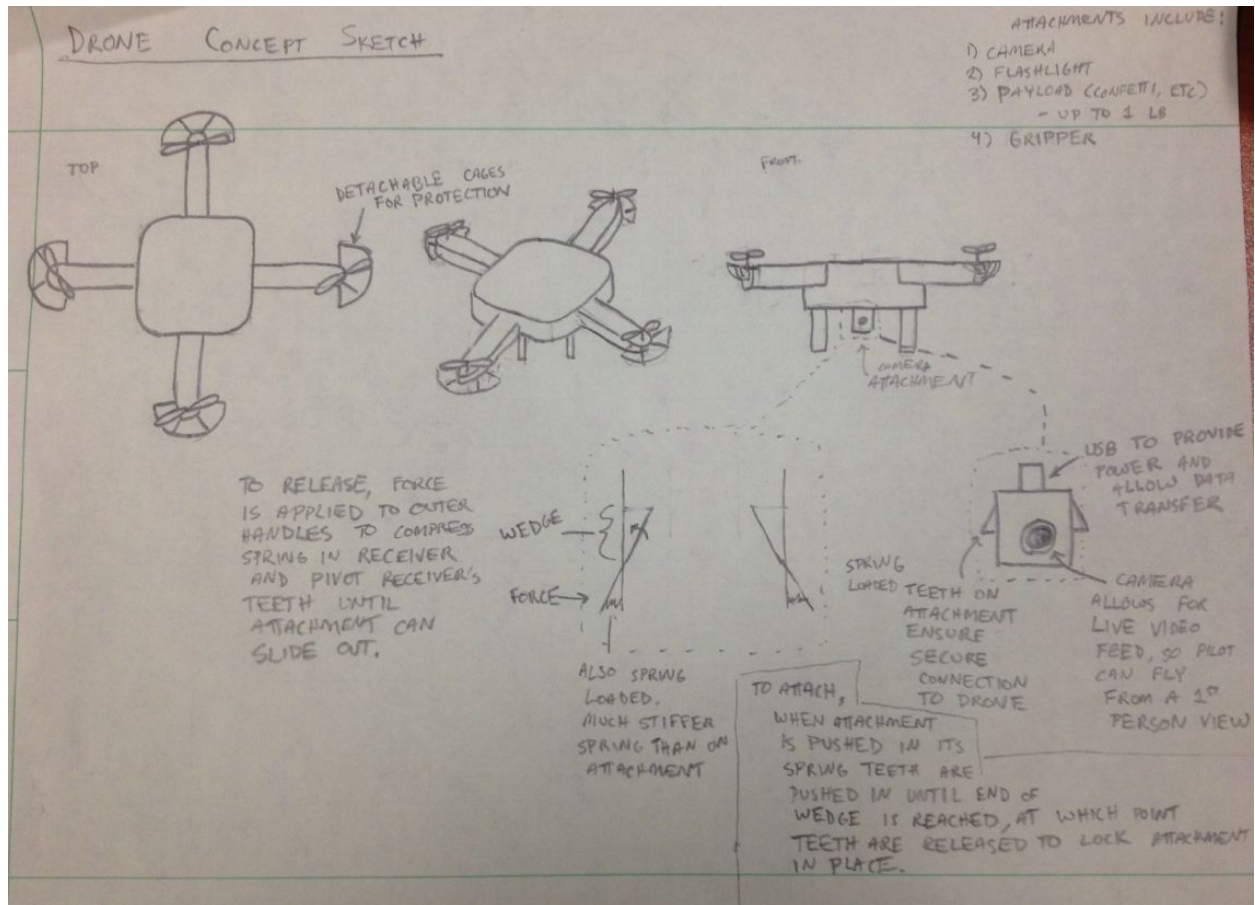

Figure 4: #4) Span-On and USB Connection

### 3.3 A concept selection process

#### 3.3.1 Concept scoring



Example Template		Metric								
		Height	Diameter	Structural Strength	Salvaged Drone Cost	3D Frame Cost	Accessories Cost	# of Functions	Self-(de)attachable	Battery Duration
Need#	Need	1	2	3	4	5	6	7	8	9
1	Drone is light enough to fulfill aerial functions	0.25	0.3	0.1						0.35
2	Drone is somewhat shock-resistant	0.25	0.25	0.5						
3	Drone is between 25 and 100 cm in diameter		0.5	0.3		0.2				
4	Drone is less than 25 cm tall	0.5		0.3		0.2				
5	Drone lasts more than 5 minutes									1
6	Drone costs less than \$500				0.4	0.2	0.3			
7	Drone has at least 3 functions						0.45	0.45	0.1	
8	Drone can attach/deattach accessories								1	
Units		cm	cm	cm	\$	\$	\$	n/a	Binary	min
Best Value		10	25	150	50	5	20	3	1	10
Worst Value		30	100	0	200	40	200	0	0	0
Actual Value		25	60	110	150	25	100	3	1	7
Normalized Metric Happiness		0.25	0.5333333	0.7333333	0.3333333	0.4285714	0.5555556	1	1	0.7
Actual Value		20	50	110	200	25	70	3	1	6
Normalized Metric Happiness		0.5	0.6666667	0.7333333	0	0.4285714	0.7222222	1	1	0.6
Actual Value		15	40	110	150	25	70	3	1	6
Normalized Metric Happiness		0.75	0.8	0.7333333	0.3333333	0.4285714	0.7222222	1	1	0.6
Actual Value		10	60	110	150	25	70	3	1	8
Normalized Metric Happiness		1	0.5333333	0.7333333	0.3333333	0.4285714	0.7222222	1	1	0.8

Need Happiness	Importance Weight (all entries should add up to 1)	Total Happiness Value	Need Happiness	Importance Weight (all entries should add up to 1)	Total Happiness Value	Need Happiness	Importance Weight (all entries should add up to 1)	Total Happiness Value	Need Happiness	Importance Weight (all entries should add up to 1)	Total Happiness Value
0.5408333	0.15	0.081125	0.608333333	0.15	0.09125	0.7108333	0.15	0.106625	0.763333333	0.15	0.1145
0.5625	0.1	0.05625	0.658333333	0.1	0.0658333	0.7541667	0.1	0.0754167	0.75	0.1	0.075
0.572381	0.15	0.0858571	0.639047619	0.15	0.0958571	0.7057143	0.15	0.1058571	0.572380952	0.15	0.0858571
0.4307143	0.1	0.0430714	0.555714286	0.1	0.0555714	0.6807143	0.1	0.0680714	0.805714286	0.1	0.0805714
0.7	0.05	0.035	0.6	0.05	0.03	0.6	0.05	0.03	0.8	0.05	0.04
0.3857143	0.2	0.0771429	0.302380952	0.2	0.0604762	0.4357143	0.2	0.0871429	0.435714286	0.2	0.0871429
0.8	0.15	0.12	0.875	0.15	0.13125	0.875	0.15	0.13125	0.875	0.15	0.13125
1	0.2	0.2	1	0.2	0.2	1	0.2	0.2	1	0.2	0.2
<b>Total Happiness</b>	<b>0.6984464</b>	<b>Total Happiness</b>	<b>0.7302381</b>	<b>Total Happiness</b>	<b>0.8043631</b>	<b>Total Happiness</b>	<b>0.8143214</b>	<b>Total Happiness</b>	<b>0.8143214</b>	<b>Total Happiness</b>	<b>0.8143214</b>

Figure 5: User Needs Metrics Table

Figure 5: User Needs Metric Table

### 3.3.2 Preliminary analysis of each concept’s physical feasibility

#### Design #1) Custom “X” Attachment and USB Connection:

A large difficulty in designing the plus-sign attachment is the additional weight and cost caused by the extra motor, needed to move the rods used to fix the accessory attachment. The plus-sign attachment ensures the stability of the accessory, and additionally, seamlessly adapts it into the drone, completing a simple and clean design. Another difficulty comes from adapting accessories into the required plus sign attachment. Worst case scenario, the accessory becomes a little bulky. However, the two-piece drone frame has the large benefit of being easy to print through 3D printing, due to its simple design with flat surfaces on each piece. Furthermore, 3D printing has the benefit that, if the frame breaks, it can be reprinted for a very cheap cost.

#### Design #2) Electromagnet and Wi-Fi:

Concept 2 relies on attaching and de-attaching a component to a drone via an electromagnet. The mechanism of this concept is fairly simple, as it has no moving parts in the attachment and dis-attachment. Unlike a fully-mechanical mechanism, this concept will require extra sources of energy (i.e. current) in order to operate the

electromagnet, and it would require a separate radio control device to cease or continue the current. Manufacturing would be fairly simple. The electromagnet would come from a third party, and wiring in the drone casing would be fairly simple. The electromagnet will come with possible attachments, and could be glued on in the cheapest scenario. A difficulty that arises with this concept is the extra weight that may inhibit the operation of the drone. A benefit is that the drone does not have to be fully aligned with the attachment to effectively pick it up.

**Design #3) Buckle, Dock, and USB Connection:**

The design of Concept 3 proposes to solve the issue of picking up, retrieving, carrying, and reloading an interchangeable device with a buckle mechanism, similar to that on a traditional backpack. Our project inherently will face the difficulties of lifting items due to their weight and simple operation of picking the device up. The drone itself embodies a quad-copter design, with four propellers located equidistantly from the center base of the drone. Additionally, the base and the blades will be designed and 3D-printed, drawing from inspiration from existing models of successful drone technology. The design of the device platform features 2 male buckle components, facing upwards, opposite of each other on the port and starboard sides of the platform. Every interchangeable device will hold a standard device platform, allowing for simple exchange. The bottom of the base will feature two female buckle components, attaching to the male component on the device platform. The loading dock allows for the drone to be guided to the landing spot with the four aligning arms. It holds a cylindrical base to hold the device platform, with magnets to hold it in the correct place. It also features a mechanism that will allow it to detach the male and female buckles from each other.

**Design #4) Snap-On and USB Connection:**

A large difficulty of accommodating multiple interchangeable attachments for a drone is being able to quickly and easily attach and detach the different components while still ensuring a secure connection between the component and the drone. Attaching the components implementing spring-loaded teeth on both the component and the drone's receiving port is a viable option without much additional weight, and no necessary motors. Simply, when the component is slid into the port, its teeth are compressed until it passes the teeth of the port, at which point the spring releases and the component is locked into place. In order to release the component, push on the tabs of the port to compress the spring and retract the teeth of the port, allowing the component to easily slide out. Another difficulty pertaining to multiple attachments is the customization of data connection concerning each specific part. A flashlight requires power to illuminate, as does a payload for the doors to open, and a gripper to operate the hand, while a camera requires both power and a way to transmit the data

so that the pilot is able to receive a live video feed and can pilot the drone in first person. It appears that this is possible by making the connection a USB connection in order to satisfy the different needs of each component. This still create a more costly and complex connection than a simple power source, but is needed to the goals of the product.

### 3.3.3 Final summary

#### Winner: **Design #3) Buckle, Dock, and USB Connection**

Concept 3 has several advantages, primarily in its design of the loading dock, along with the universality of the device platform. Similar to the other concepts, it features a lightweight drone, with four arms, each holding a propeller in a quad-copter fashion. It faults in the complexity of the drone base design, though combined with the simplicity of design of Concept 4 and the versatility of Concept 1, it will succeed in achieving aerodynamics capable of flight. The alignment arms guide the drone to the same location during each landing and takeoff, allowing for easy transfer of the interchangeable device. The attachment mechanism will merge with the feasibility of Concept 1, inhibited by electro-restrictions in Concept 4. Adapting from Concept 1, a USB connection will be utilized to redirect all controls to one central Arduino board. The design has few protruding sharp edges, and should pose no significant danger to pedestrians passing by. It consists of few moving parts other than the blades, and has a relatively simple mechanism.

## 3.4 Proposed performance measures for the design

### Performance Goals:

1. Drone can fly for at least 5 minutes.
2. Drone has at least 3 different accessories.
3. Overall costs are \$500 or less.
4. Drone is 40 cm in diameter.
5. Drone is 25 cm in height.
6. Drone can sustain a drop from an altitude of 1 meter.
7. Drone can attach and detach to accessories without manual help.
8. Drone weighs less than 1 pound.

## 4 Embodiment and fabrication plan

### 4.1 Embodiment drawing

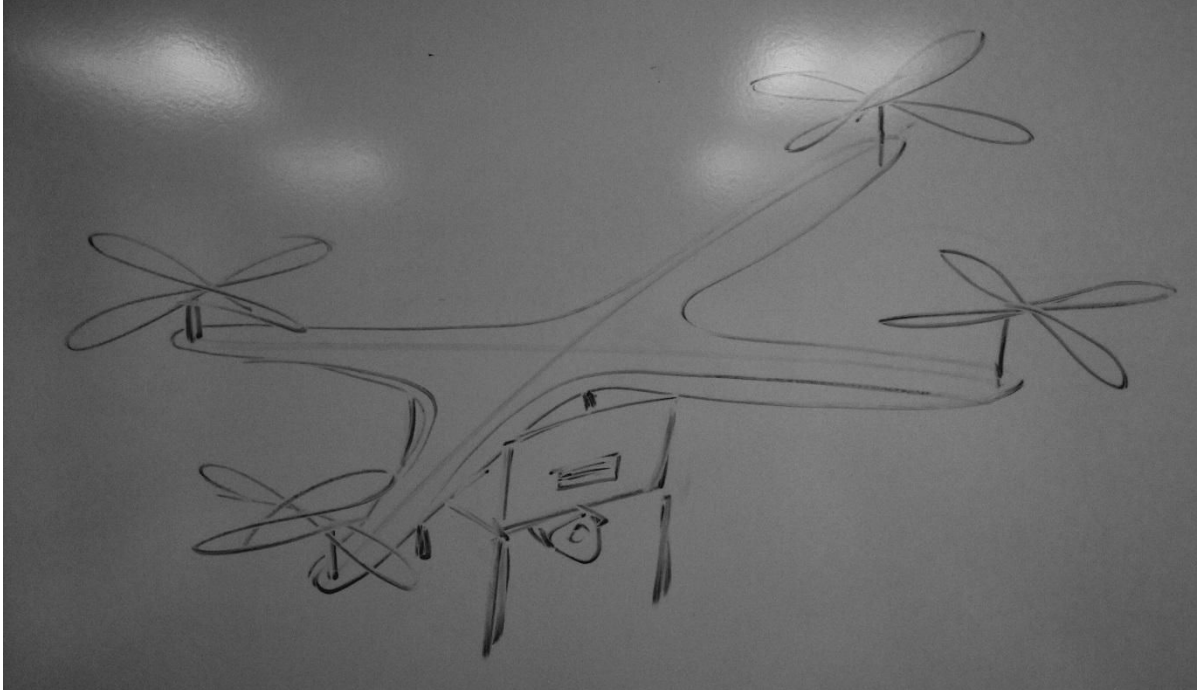

Figure 6: Embodiment Drawing

### 4.2 Parts List

Table 5: Parts list with costs and quantities

	<i>Part</i>	<i>Source</i>	<i>Supplier Part Number</i>	<i>Unit price</i>	<i>Quantity</i>	<i>Total price</i>	<i>Description</i>
1	Syma X5C Explorers 2.4G 4CH 6-Axis Gyro RC Quadcopter With HD Camera	Amazon	X5C	\$45.90	2	\$91.80	Drone
2	1st Person View Camera	Amazon		\$6.99	1	\$6.99	1st person view

3	Accessory Flashlight	Amazon		\$9.95	1	\$9.95	Illuminate ground
4	RF Remote Control	Adafruit		\$10.95	1	\$10.95	RF transmitter
5	RF Receiver	Adafruit		\$9.82	1	\$9.82	RF receiver
6	USB Extension	Amazon		\$3.12	1	\$3.12	Male-female USB cord
7	Arduino	Amazon		\$15.90	1	\$15.90	Microcontroller
8	Fabricated Attachment Box	Art School	Custom	\$20.90	1	\$20.90	Original electronics box
9	Fabricated Attachment Buckle	Art School	Custom	\$7.30	1	\$7.30	Original accessory attachment
10	Fabricated Platform	Art School	Custom	\$27.30	1	\$27.30	Hold attachment
11	Power Truck Radio Control Truck Lift	Amazon	FD-2695 B	\$14.95	1	\$14.45	To raise the docking platform
12	Zippy #1 Type Knife	Campus Bookstore	008618177	\$2.75	1	\$2.95	To cut the wood for the electronics box
13	Basswood 3/32x1x24 15 Pcs	Campus Bookstore	000206207	\$1.18	1	\$1.26	To make the electronics box
14	Basswood 3/16x1/4x24 30 Pcs	Campus	000216017	\$0.50	1	\$0.54	To make the

		<b>Books tore</b>					<b>electronic s box</b>
<b>15</b>	<b>Basswood Sheet 1/16x6x24 10 Pcs</b>	<b>Camp us Books tore</b>	<b>0002160 36</b>	<b>\$5.52</b>	<b>2</b>	<b>\$11.82</b>	<b>To make the electronic s box</b>
<b>16</b>	<b>Art/Print/Photogra phic Supply (Box Cutter)</b>	<b>Camp us Books tore</b>	<b>0000000 74</b>	<b>\$2.50</b>	<b>1</b>	<b>\$2.68</b>	<b>Box-cutte r to cut thicker wood</b>
<b>17</b>	<b>Super Glue</b>	<b>Camp us Books tore</b>	<b>0000000 74</b>	<b>\$5.99</b>	<b>1</b>	<b>\$6.42</b>	<b>To assemble parts with strength</b>
						<b>\$259.1 0</b>	

4.3 Draft detail drawings for each manufactured part

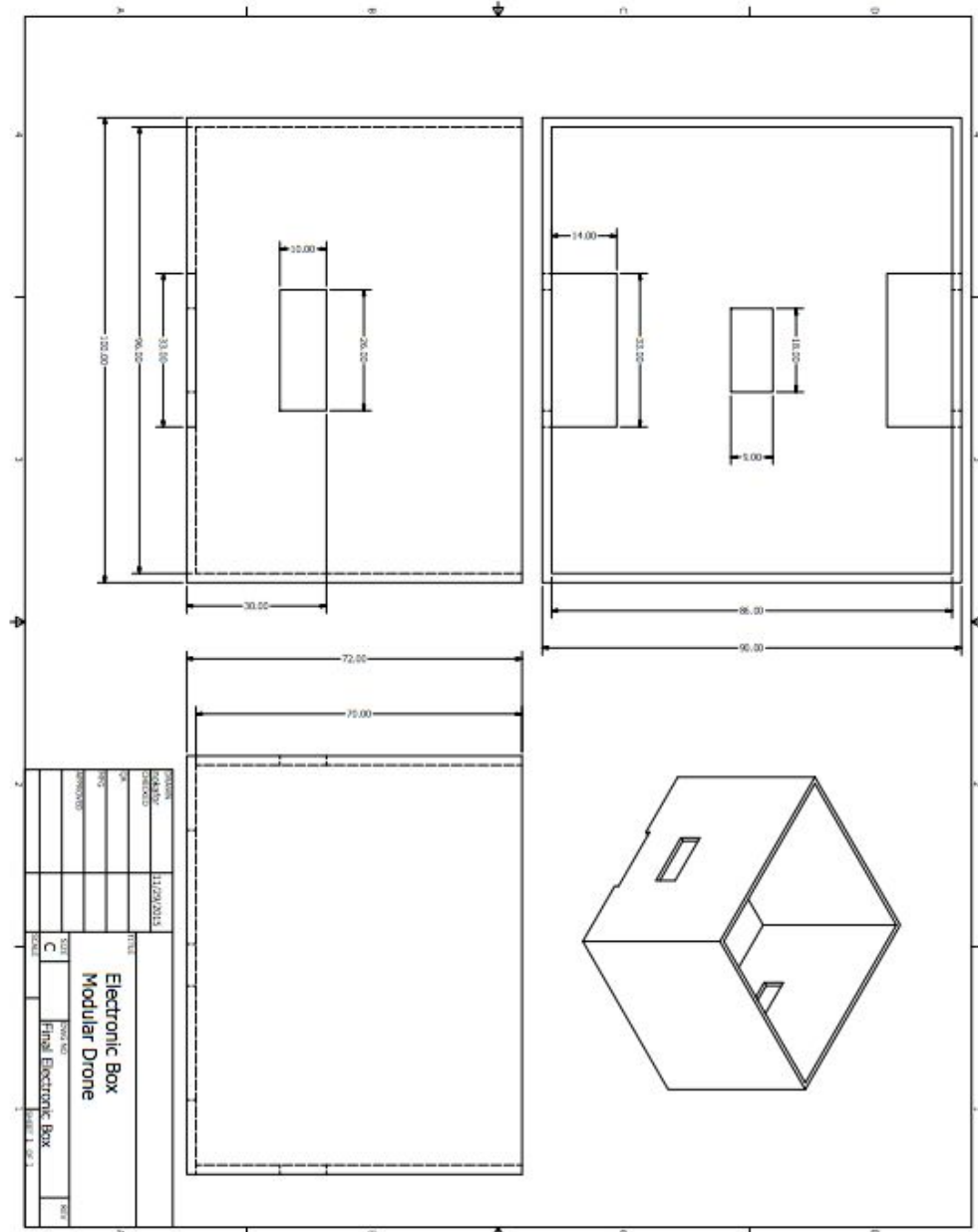

Figure 7: Electronics Box



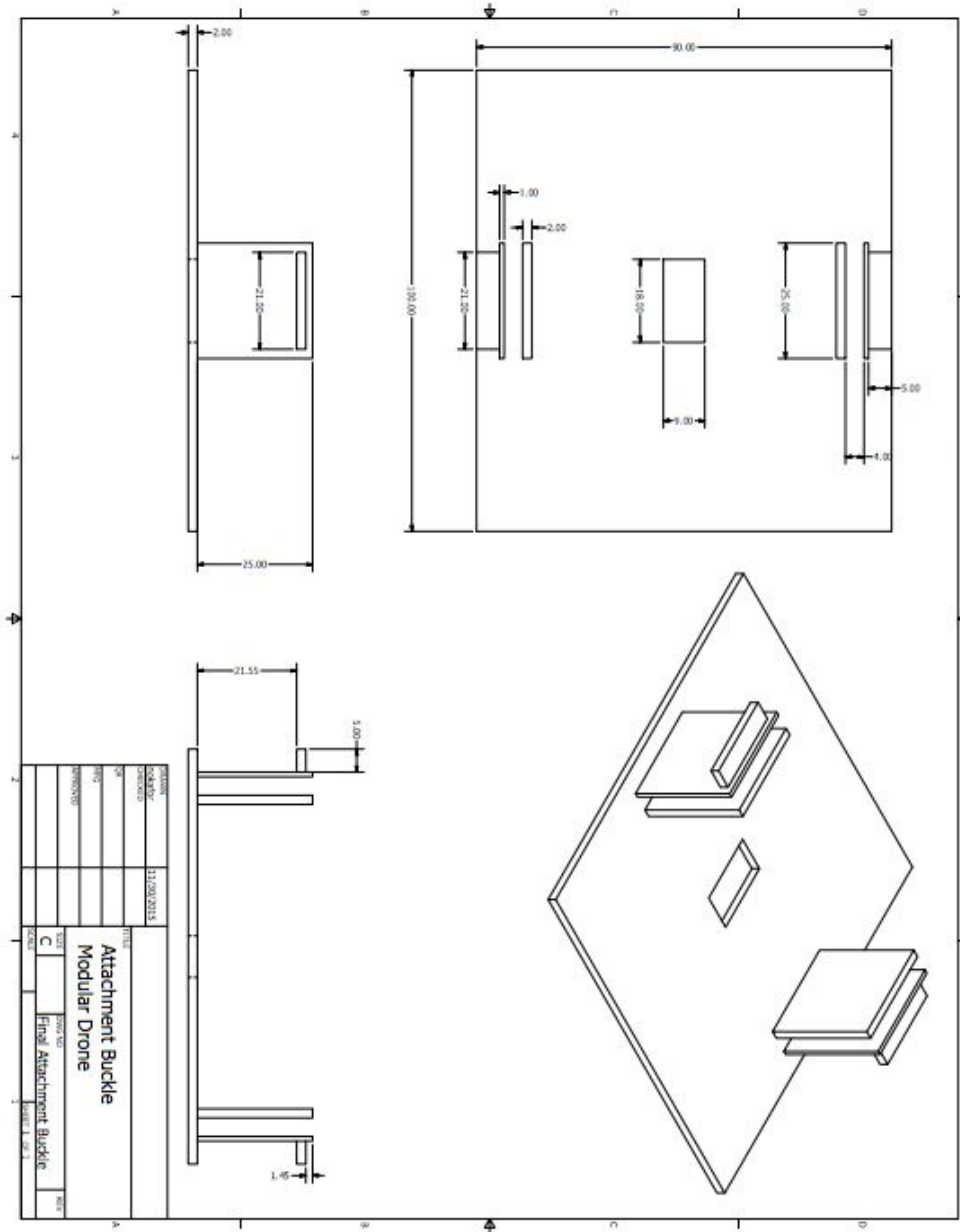

Figure 8: Attachment Buckle

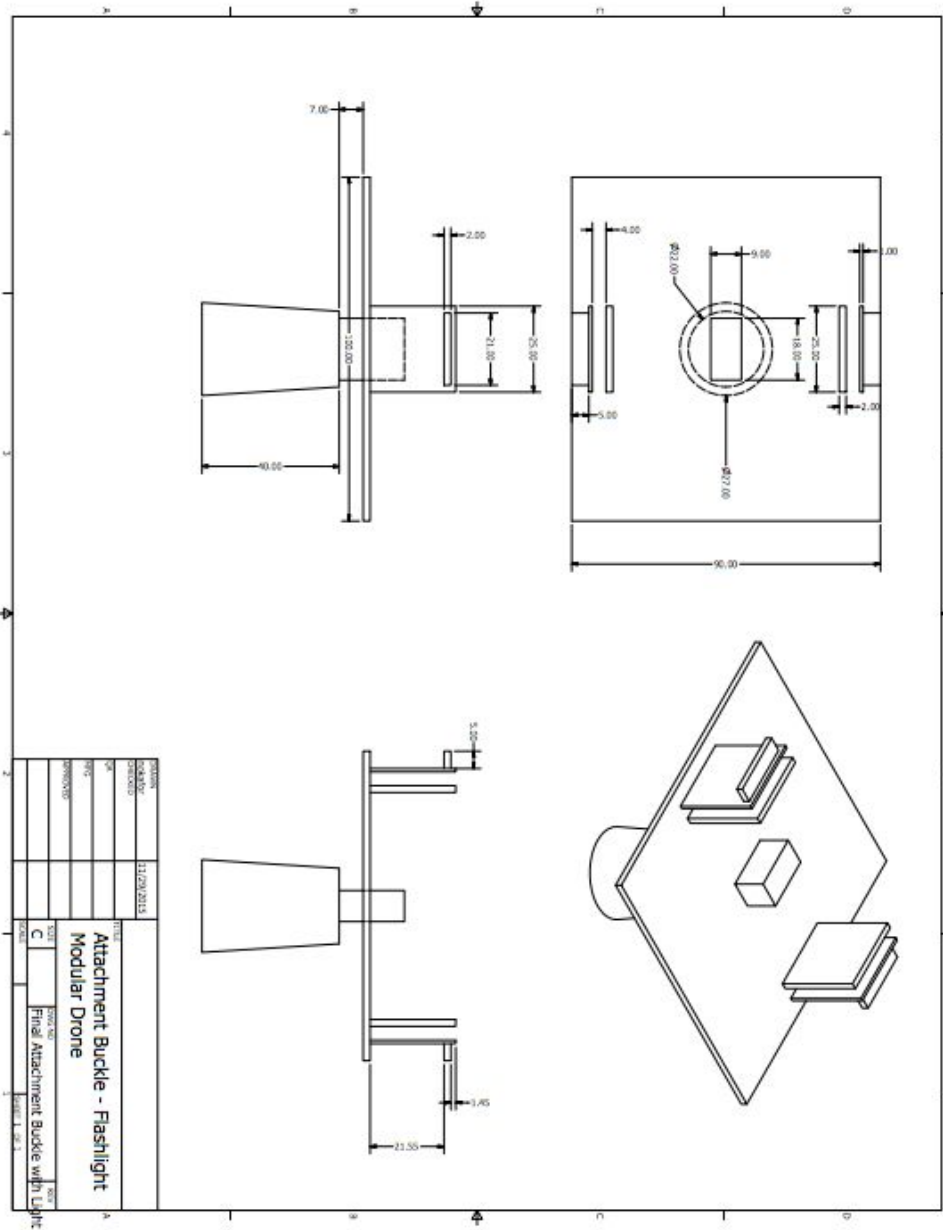

Figure 9: Attachment with Flashlight Accessory

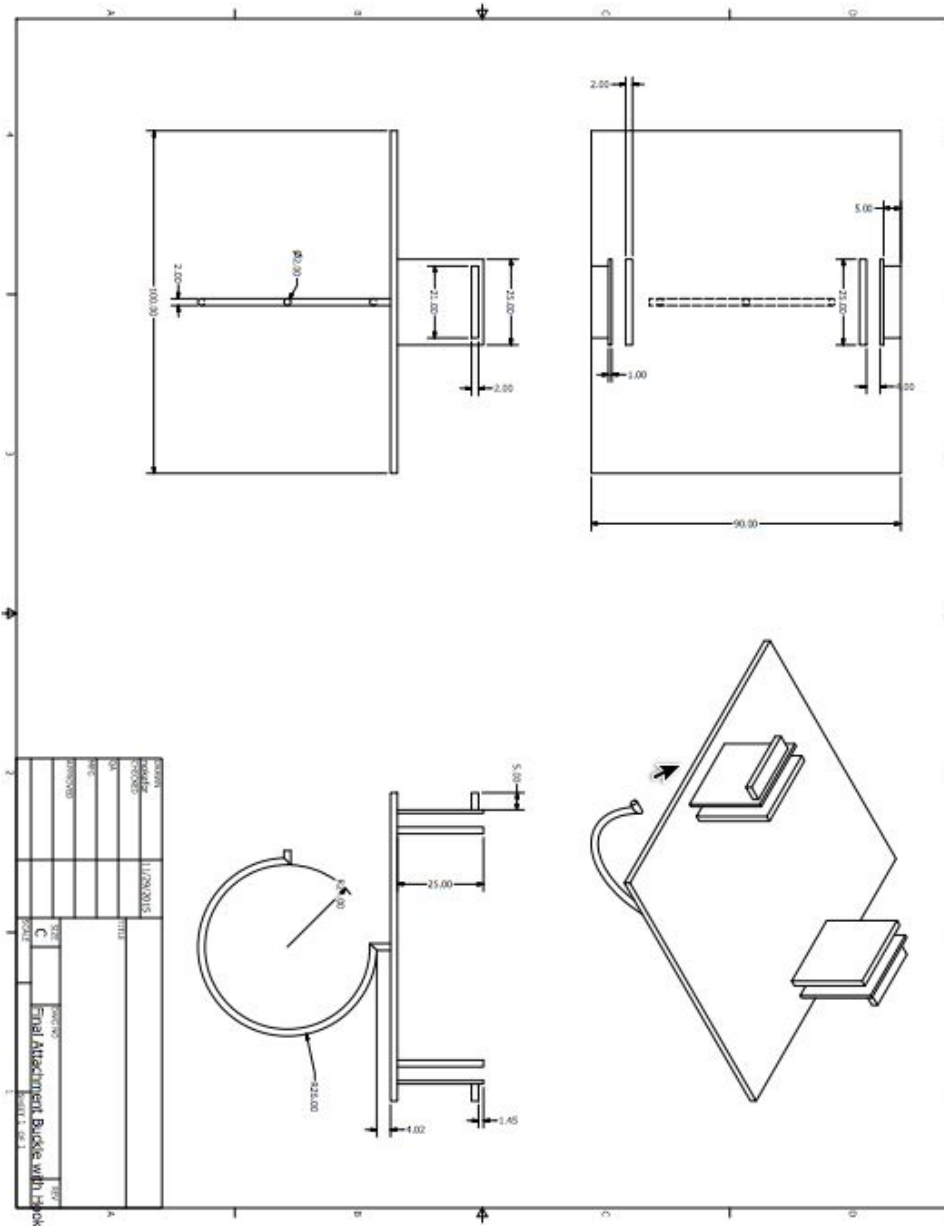

Figure 10: Attachment with Hook Accessory

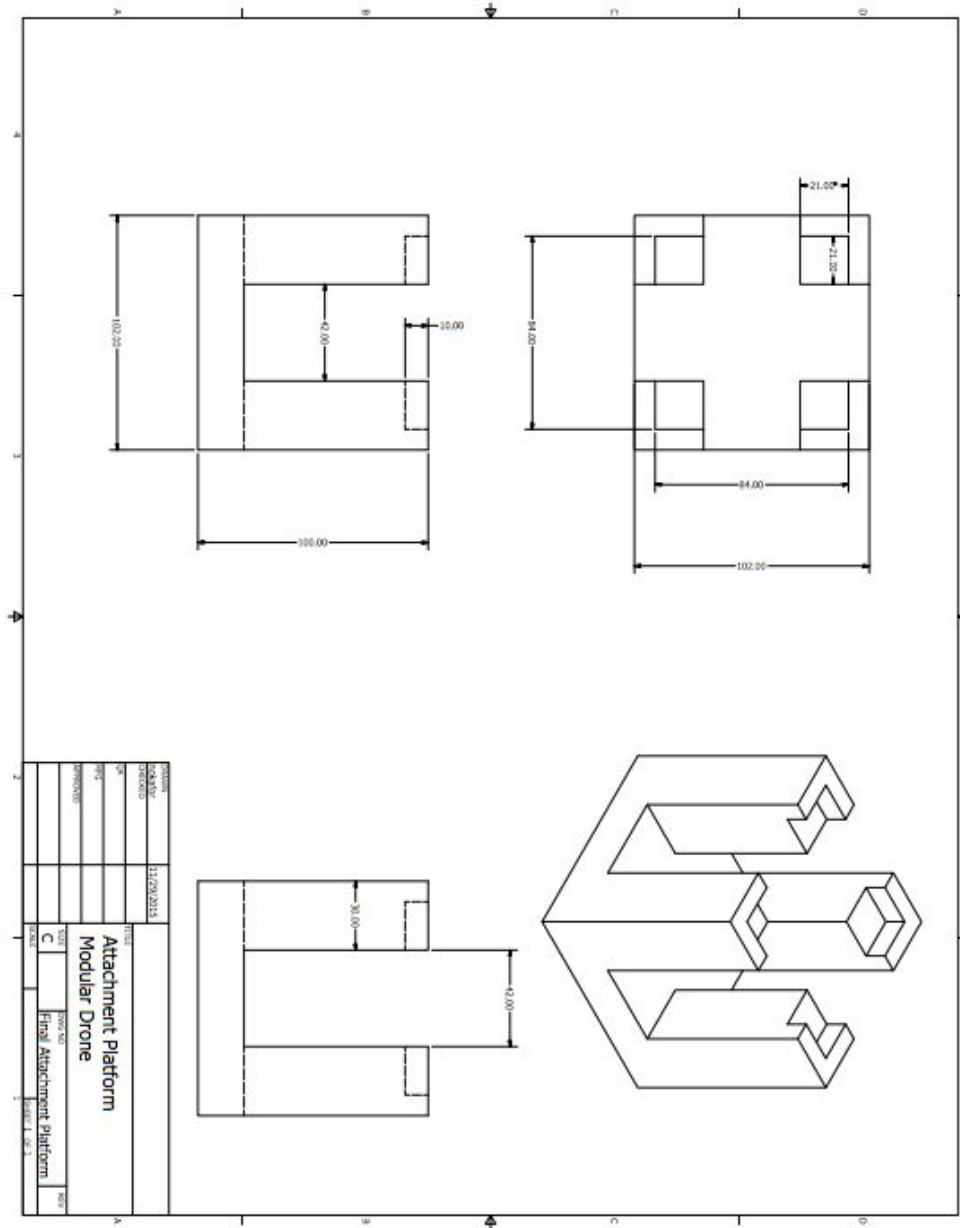

Figure 11: Attachment Platform

#### 4.4 Description of the design rationale for the choice/size/shape of each part

For the most effective modular drone, we determined that the housing and structural material needed to be as light as possible. 3D printed material was originally chosen to construct all of our structural components, because the material is reasonably strong, and it is easy to make the parts

to our design specifications with this material. However, the drone purchased to base our product off of was very cheap, and therefore did not produce enough thrust to carry much more than itself and still be capable of flight.

Due to weight considerations, basswood was chosen as our prototyping material. While not particularly strong, basswood is extremely light and easy to work with, so that it would be possible to show a proof of concept. For this reason, basswood was chosen to be the material of all the attachment platforms and mechanisms, as well as the box to house the electronics and extension cables.

Because of the size of the Arduino, the electronics box was required to be rather large, which added additional weight to the overall design. A rectangular shape was used to fit the arduino, and also because the aerodynamics of the drone were not a driving factor into our design, since the aircraft does not move laterally at fast speeds for a large amount of time. The size of the attachment platform had to match the size of the electronics box so that the attachment mechanism would work properly, which further added material and weight to the payload of the drone, further limiting its flight capability.

For a commercial product, more abilities are available to use. Instead of 3D printing or basswood, extremely light and thin injection plastics can be employed for the structural components of the drone and its modular capabilities. Injection plastics will ensure a lightweight yet strong structure will more flight capability. Another big change to a commercial product would be that instead of a reprogrammable Arduino microcontroller, the electronics would be controlled by a industrial mass-produced chip, which is less than a tenth of the size of the Arduino, and requires less power. This saves weight on batteries, which contributed a lot to the weight of the electronics box. This change also requires less space, meaning that the box and attachment platform can be much smaller, further reducing weight.

## 5 Engineering analysis

### 5.1 Engineering analysis proposal

#### 5.1.1 A form, signed by your section instructor

##### **ANALYSIS TASKS AGREEMENT**

PROJECT: Modular Drone NAMES: David Brablec INSTRUCTOR: Jakiela  
Nick Okafor  
Jordi Turner  
Isaac Witte

The following engineering analysis tasks will be performed:

David

- Maximum weight capacity of attachment
- Compressive strength of attachment mechanism rods

Nick

- Aerodynamics of the frame/drone body
- Feasibility of attachment and detachment process

Jordi

- Frame structural strength/durability
- Maximum height drone may be able to reach

Isaac

- Maximum speed drone may be able to achieve
- Ease of attachment

Instructor signature: \_\_\_\_\_; Print instructor name: \_\_\_\_\_

(Group members should initial near their name above.)

Figure 12: Analysis Tasks Agreement

## 5.2 Engineering analysis results

### 5.2.1 Maximum Weight Capacity of the Attachment

The maximum weight capacity of the drone is 209 g, meaning that the maximum weight of an attachment is 100 g. In a commercial product a drone with greater lift capability would be used, or a custom made drone would be manufactured with the ability to lift several times its own weight. The reason that the prototype drone was chosen was its minimal cost, and does not fulfill the needs of our product for commercial satisfaction.

### 5.2.2 Compressive Strength of the Attachment Mechanism Rods

The compressive strength of the attachment mechanism rods is 0.3926 N. This force signifies the force needed to bend the outer buckle as far as it can go until it reaches the inner buckle, which provides the attachment buckle additional strength and rigidity.

### 5.2.3 Aerodynamics of the Frame/Drone Body

Because we began with an already working drone and frame, the aerodynamics were not changed. The frame remained the same, with very few edges so that the airflow is not separated. The electronics box and attachments are in the shape of square, due to the shape and size of the electronics. The commercial product would have a small industrial microchip to handle all of the electronics, so the box and attachments could be much smaller and more curved to have a more aerodynamic shape.

### 5.2.4 Feasibility of Attachment and Detachment Process

Our attachment and detachment mechanism are very feasible and simple, but is manual. The autonomous mechanism has been theoretically solved but was not applied for this class. Theoretically, the drone would land in the capture area, which is slanted downward so that the drone has a controlled descent until it has reached the bottom of the dock. Once that point is reached, and IR sensor is triggered, which then causes a motor to raise a platform and attaches the component to the drone. In order to also facilitate detachment another sensor would have to be employed to tell if there was a component already detached, as well as a more advanced gripper mechanism that is capable of nimble detaching the component and moving it away from the drone so that it can be replaced.

### 5.2.5 Structural Strength

The original drone is able to sustain repeated falls without damage, so its structural strength is sound. With the prototype box this strength fell, as the box was made of weak balsawood material. The commercial product would be injection plastic

material and would be securely fastened to the drone, so the structural strength would be the same as the original drone. If additional durability was needed wider legs with shock absorbent springs could be manufactured.

#### 5.2.6 Maximum Height

When modified the drone was only able to reach the height of 6 inches. This is because the components used throughout this project were chosen on the baseness of cost and ability to change our ideas. Instead of a condensed industrial microchip we used the editable microcontroller Arduino, and used commercial batteries instead of industrial ones. Additionally, the drone picked was a very cheap drone with very little lift capabilities, and for a commercial application a better drone would be used.

#### 5.2.7 Maximum Speed

Ground speed is not as applicable for drones, as it is rare for the user to desire a drone to move as quickly horizontally as possible. In addition, the modified drone had limited flight capability, so the maximum speed is even less relevant.

#### 5.2.8 Ease of Attachment

Our attachment process was extremely simple, and required only one or two seconds with minimum force needed. All that is required is to make sure the component is facing the correct direction so that the ports line up, and then apply inward pressure to the outer buckle and ease the component upward into the electronics box, until the outward buckle reaches the window in the box and locks into place. In order to detach a mechanism, apply downward and inward pressure on the outer buckle through the window in the box until the component slides out and fully detaches.

## 6 Working prototype

### 6.1 A preliminary demonstration of the working prototype

This video ([https://youtu.be/\\_lh\\_-7HqpGc?t=1m41s](https://youtu.be/_lh_-7HqpGc?t=1m41s)) shows one our final prototypes. Initially, we show how the attachment mechanism works, and how each of the 3 sample attachments mechanically fit into the attachment box retrofit on the drone. The mechanical attachment mechanism is a buckle system.

The hook is solely a mechanical attachment. Once the attachment buckles into the attachment box, it is ready to go!

The camera needs to connect electrically on top of mechanically. There is a video data connection port for the camera to connect to the electronics in the attachment box. Once the drone is turned on, the camera turns on as well. It is connected to the central chip in the drone.



The flashlight connects to the electronics in the attachment box via a USB connection. The Arduino and a remote control shield allow the flashlight to be controlled on and off by a remote control that has a range of up to 100 feet. All programming was custom programming, and code for attachments like this on drones is something that has not been patented or pursued.

## 6.2 Prototype photos



Figure 13: Front View of Entire System – Drone and Attachment Box



Figure 14: Inside View of Electronics in Attachment Box

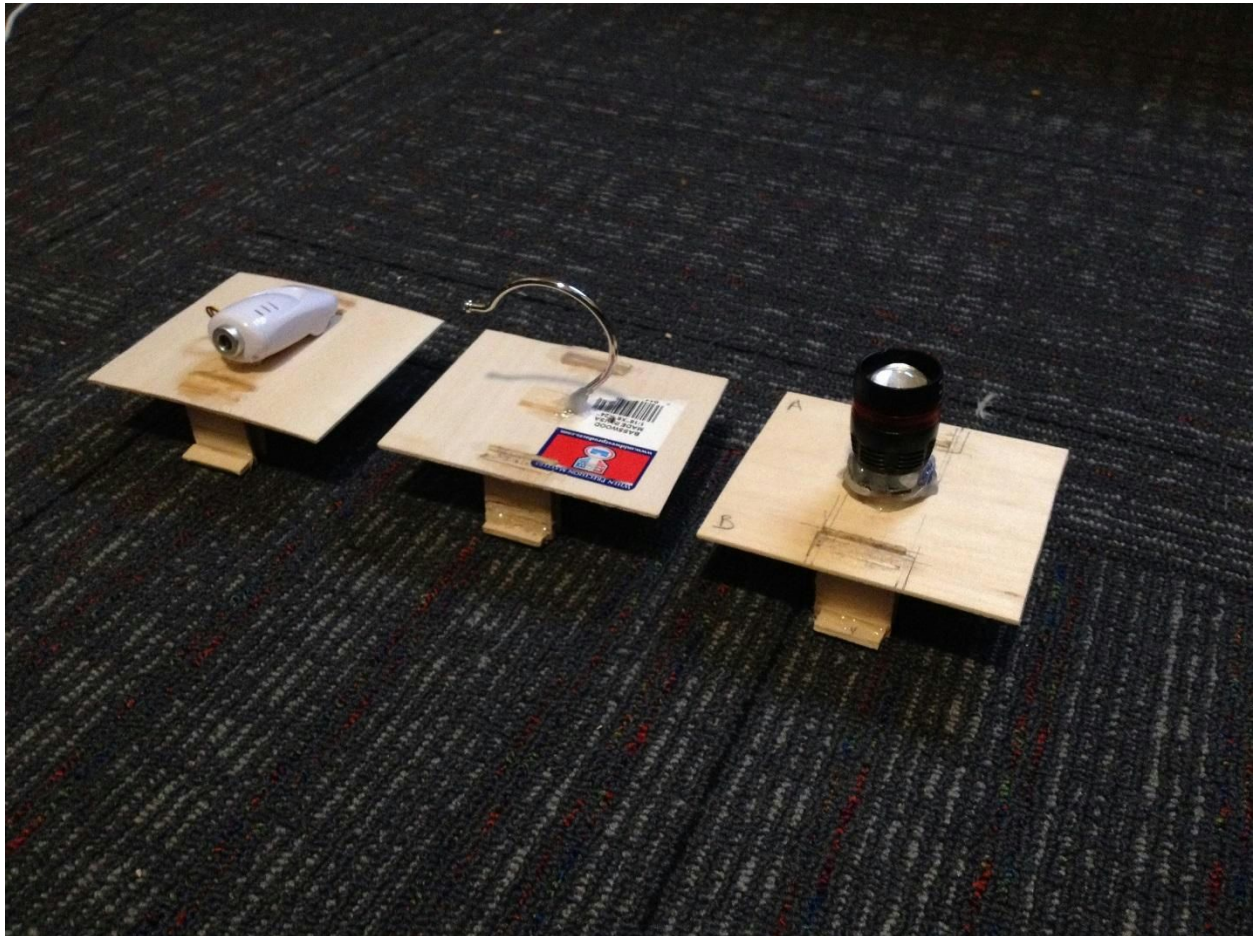

Figure 15: Three Possible Attachments – Camera, Hook, Flashlight

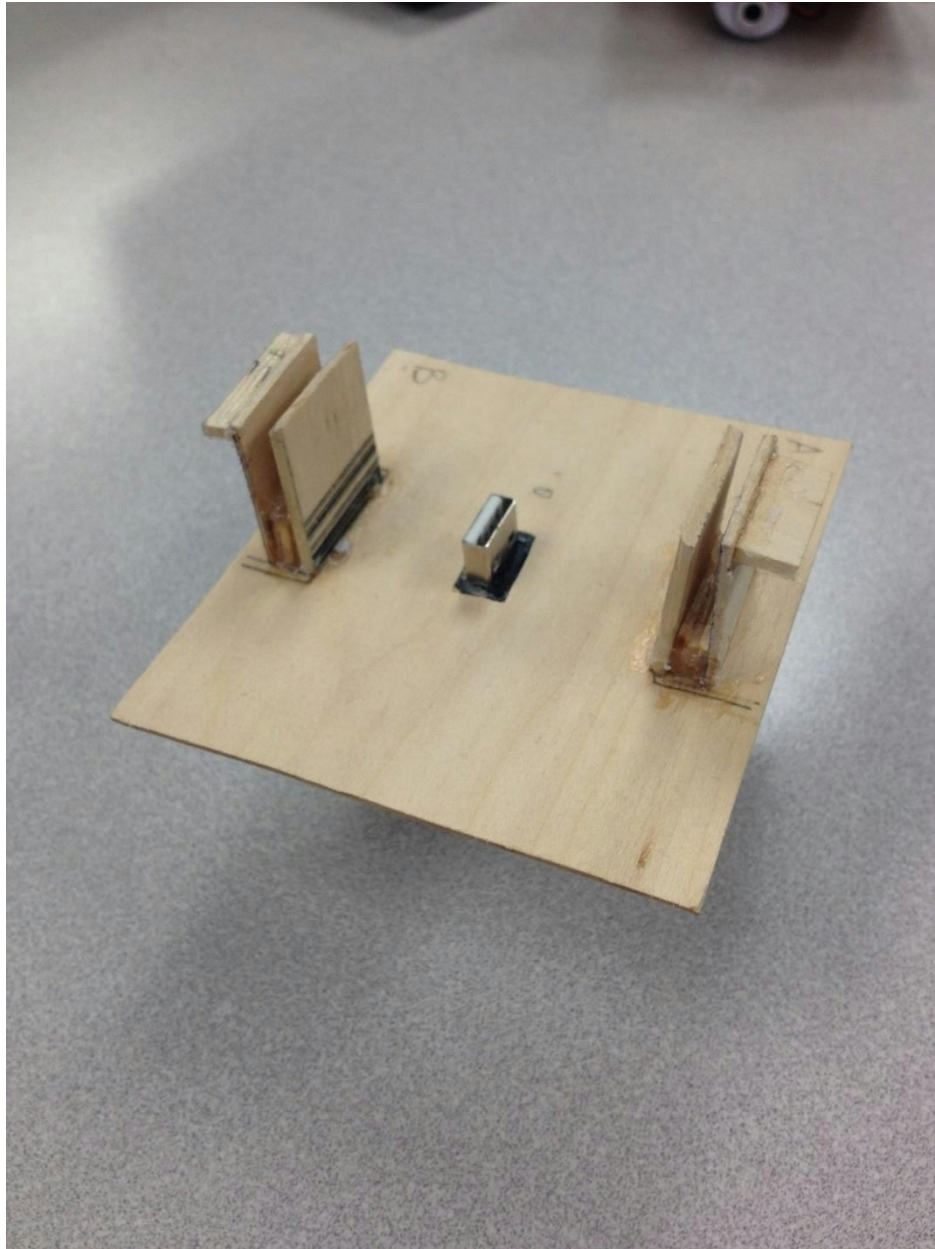

Figure 16: Attachment Mechanism on the Attachment – Buckle and USB shown

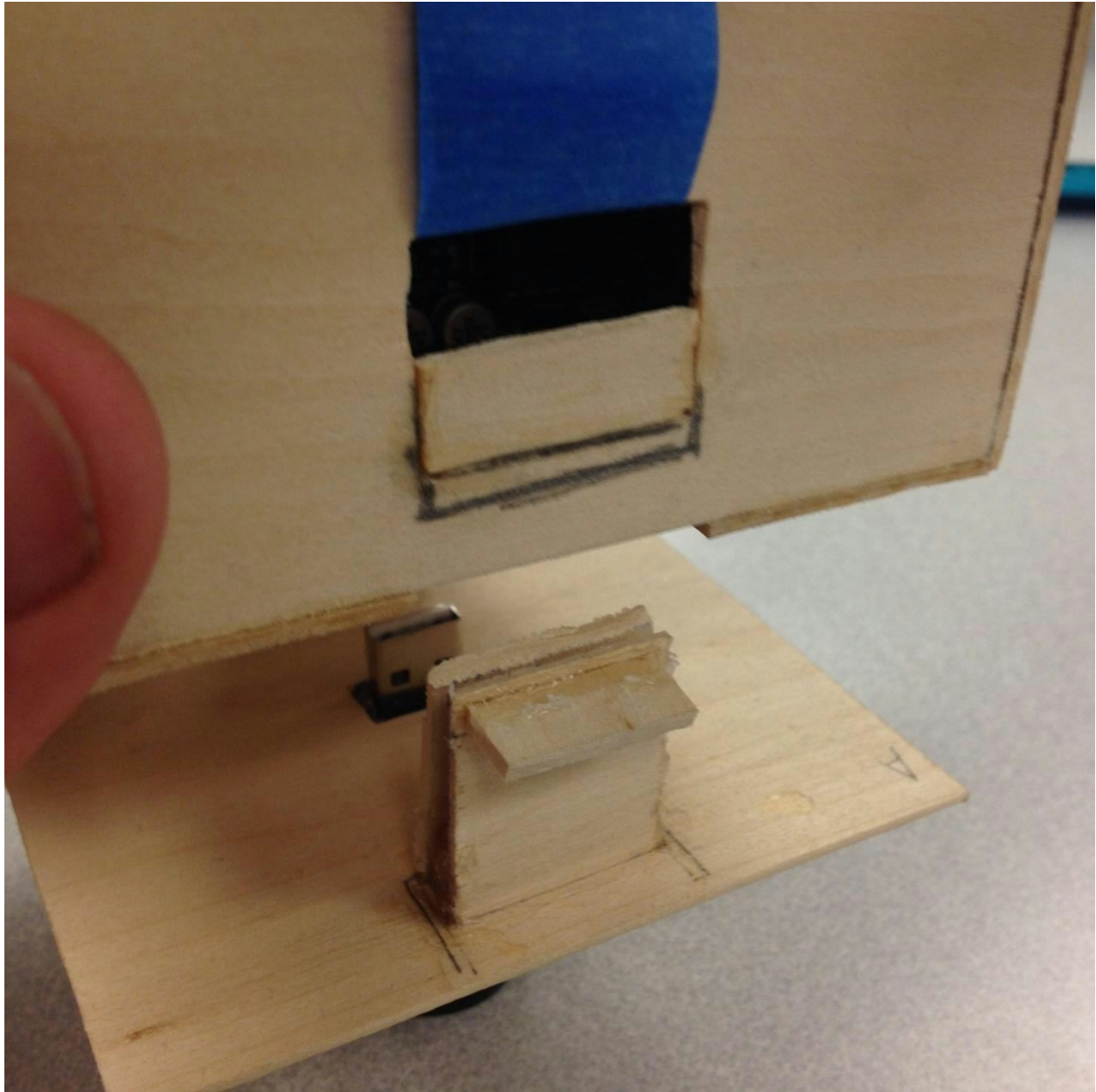

Figure 17: Close Up of how Attachment Box and Attachment Should Be Attached



Figure 18: Attachment Box and Attachment Shown Attached

### 6.3 A short videoclip that shows the final prototype performing

This video clip ([https://youtu.be/\\_lh\\_-7HqpGc?t=1m41s](https://youtu.be/_lh_-7HqpGc?t=1m41s)) shows our final working prototype in use. It can be seen that it fulfills most of our key design metrics. It can be operated by a single user, the drone is able to fly, and the attachments are able to connect electromechanically.

## 7 Design documentation

### 7.1 Final Drawings and Documentation

**7.1.1 A set of engineering drawings that includes all CAD model files and all drawings derived from CAD models.**

The CAD drawings can be found in Appendix C.

### 7.2 Final Presentation

**7.2.1 A link to a video clip of final presentation**

Our final PowerPoint presentation with audio is uploaded to Youtube at the address: <https://www.youtube.com/watch?v=SysObdTKC8E>



### 7.3 Teardown

TEARDOWN TASKS AGREEMENT

PROJECT: Modular Drone NAMES: Jodi Turner INSTRUCTOR: Makst  
Nick Okafor  
David Brabner  
Isaac Witte

The following teardown/cleanup tasks will be performed:

Workspace has been cleaned  
Tools are put away  
Drone & accessories are still in use  
Swept in jolley basement

Instructor comments on completion of teardown/cleanup tasks:

Instructor signature: Mary Makst Print instructor name: Mary Makst  
Date: 12/7/15

(Group members should initial near their name above.)

Figure 19: Teardown Agreement

## 8 Discussion

### 8.2 Using the final prototype produced to obtain values for metrics, evaluate the quantified needs equations for the design. How well were the needs met? Discuss the result.

Our final prototype met all of our user needs metrics as expected. The accessories could be easily attached and detached, mechanically and electrically – all in less than 10 seconds. The drone has three functions: a camera, a flashlight, and a hook. The drone more than 5 minutes (approximately 7 minutes while on). The overall project cost us less than \$300, and that could be greatly reduced. Size-wise, the width of the drone is in our ranges (31cm) and so is the height, at 25 cm.

The only need we barely met was the capability to fly, as the drone with an accessory attached weight only slightly under the maximum weight limit. However, it did hover, and that could be easily remedied by using a more powerful drone.

### 8.3 Discuss any significant parts sourcing issues? Did it make sense to scrounge parts? Did any vendor have an unreasonably long part delivery time? What would be your recommendations for future projects?

Overall, our sourcing went very well. Our largest sourcing issue came down to the cost of the drone, as we wanted to buy a powerful drone, but realized the chance of having to rebuy the drone in case of a mistake or the drone not fulfilling our needs. Due to our restricted budget, and most drones costing over \$250, we used a small, \$45 yet versatile drone for our project.

Additionally, another issue was the time and cost of 3D printing. Communicating with the Art School proved to be difficult, and their printer is extremely slow. For this reason, we decided to switch over to creating a wooden prototype. However, 3D printing definitely has a strong advantage in precision and strength.

Scrounging parts did not make sense for the most part, as the mechanical structure needed to be as small and light as possible, and it would be difficult to find a part that would fit the size requirements without being custom-made. On the other hand, if the electronics can be scrounged, it would greatly reduce the cost, but this does come with the issue of wear and tear on the electronics - which can make the entire drone not work if an electrical component gives out. The parts we ordered from Amazon were reliable and came fairly quickly, thanks to Amazon Prime.

For future projects, I would recommend using Amazon Prime to order electrical components, as that worked very well for us, both in terms of effectiveness, time and cost. Moreover, I would recommend buying cheap drones - it is easy to test if the concept works and later scale the drone power to fully function. Finally, it would be best to create a

functioning model out of balsa wood, and then use a 3D printer. This accelerates the process, and reduces extraneous costs.

## **8.4 Discuss the overall experience:**

### **8.4.1 Was the project more or less difficult than you had expected?**

The project was more difficult than we expected. There were many issues we did not expect to encounter: intermittent functioning from the electronics, difficulty with 3D printing, drone power limitations, the imprecise control over the drone’s flight, and the complexity of automating the accessory attachment and detachment.

### **8.4.2 Does your final project result align with the project description?**

Our final project was able to use various accessories, all of which could be easily and quickly changed. However, the drone could barely fly with the accessories, and we were unable to have accessories automatically attach and detach.

### **8.4.3 Did your team function well as a group?**

Our group worked very well together. We have all known each other for some time, and we were very effective at splitting up tasks working on them individually or in groups. The work was given to suit each member’s strengths, and worked out pretty well.

### **8.4.4 Were your team member’s skills complementary?**

Our skills were extremely complimentary. Our different skills included circuitry, soldering, programming, CAD, marketing, and design experience. Overall, we all had a good understanding of mechanics. This turned out to be instrumental in working designing our project.

### **8.4.5 Did your team share the workload equally?**

The workload was split equally. We frequently worked together, but we always took into account the individual work from each member. The type of work for each member varied according to their strengths and skills, but the difficulty remained equal for everyone.

### **8.4.6 Was any needed skill missing from the group?**

The skills missing from the group at first was experience maneuvering the drone and familiarity with 3D printing. Aside from that, we had everything we needed with each group member’s individual expertise. Overall, we had the skills required, even if they needed to be polished.

**8.4.7 Did you have to consult with your customer during the process, or did you work to the original design brief?**

We consulted Professor Jakiela and Professor Malast about the interest and characteristics of our projects, along with the idea of the automated docking drone. However, our project was very loyal to the original design brief.

**8.4.8 Did the design brief (as provided by the customer) seem to change during the process?**

Our design brief stayed fairly constant. Originally, we only looked at a modular drone, but after talking with our customer, we added the stretch goal of the automated docking base, but that goal was sadly too optimistic. Nevertheless, the modular product still remained a good product, with high marketing value.

**8.4.9 Has the project enhanced your design skills?**

Yes, the project has definitely increased our design skills. The entire team has either gained or expanded their skills with electromechanical products, be it with soldering, or working with wood. We all understand better the approach necessary to successfully create a product, along with how to organize the process and timeline.

**8.4.10 Would you now feel more comfortable accepting a design project assignment at a job?**

Yes, the entire group feels more comfortable accepting a job involving a design project. We all have a better grasp of the entire project timeline, from conception to creation to modification. Furthermore, we are all searching for product design opportunities, as we found the project to be meaningful, interesting and occasionally fun.

**8.4.11 Are there projects that you would attempt now that you would not attempt before?**

This project has opened up many projects including both mechanics and electronics. The team has gained a lot of experience in creating a product under financial and time constraints, which will be valuable for any sort of work or product. Furthermore, this project heightened our experience working closely with teams of different experiences and backgrounds, which is useful for any type of project.

## 9 Appendix A - Parts List

Table 7: Detailed parts list

<i>Part</i>	<i>Color, TPI, other part IDs</i>
Syma X5C Explorers 2.4G 4CH 6-Axis Gyro RC Quadcopter With HD Camera	White Plastic
1st Person View Camera	Metallic Black
Accessory Flashlight	Black Metal
RF Remote Control	Black Plastic
RF Receiver	Black Plastic
USB Extension	Black Plastic
Arduino	Blue Plastic
Fabricated Attachment Box	White Plastic
Fabricated Attachment Buckle	White Plastic
Fabricated Platform	White Plastic
Power Truck Radio Control Truck Lift	Orange Plastic
Zippy #1 Type Knife	Metallic
Basswood 3/32x1x24 15 Pcs	Wood
Basswood 3/16x1/4x24 30 Pcs	Wood
Basswood Sheet 1/16x6x24 10 Pcs	Wood
Art/Print/Photographic Supply (Box Cutter)	Metallic
Super Glue	Clear Plastic

## 10 Appendix B - Bill of Materials

Table 8: Bill of materials

<i>Part</i>	<i>Source</i>	<i>Supplier Part Number</i>	<i>Quantity</i>	<i>Total price</i>	<i>Description</i>
Syma X5C Explorers 2.4G 4CH 6-Axis Gyro RC Quadcopter With HD Camera	Amazon	X5C	2	\$91.80	We chose this drone due to its cost, size (31cmx31cmx8cm), good reviews, and the included camera. Powerful enough to lift enough weight for this project
1st Person View Camera	Amazon		1	\$6.99	To help pilot the camera
Accessory Flashlight	Amazon		1	\$9.95	To illuminate the ground beneath the drone
RF Remote Control	Adafruit		1	\$10.95	The purpose of the RF remote control is to transmit a radio frequency that is received by the RF receiver inside the electronics box. Together the power to the USB connection can either be turned on or off
RF Receiver	Adafruit		1	\$9.82	The purpose of the receiver is to receive the radio frequency from the transmitter and to signal the Arduino, controlling the power to the USB port.
USB Extension	Amazon		1	\$3.12	We chose this to use the female USB port, which we soldered to wires connected to the Arduino.

Arduino	Amazon		1	\$15.90	The Arduino was the microcontroller that controlled the power supplied to the USB port, by using the RF transmitter and receiver. Further work could be done with minimal code changes to collect data via the USB cable as well.
Fabricated Attachment Box	Art School	Custom	1	\$20.90	Original electronics box
Fabricated Attachment Buckle	Art School	Custom	1	\$7.30	Original accessory attachment
Fabricated Platform	Art School	Custom	1	\$27.30	To hold the accessory attachment when attaching it to the drone
Power Truck Radio Control Truck Lift	Amazon	FD-2695B	1	\$29.40	To raise the docking platform
Zippy #1 Type Knife	Campus Bookstore	008618177	1	\$2.95	To cut the wood for the electronics box
Basswood 3/32x1x24 15 Pcs	Campus Bookstore	000206207	1	\$1.26	To make the electronics box
Basswood 3/16x1/4x24 30 Pcs	Campus Bookstore	000216017	1	\$0.54	To make the electronics box
Basswood Sheet 1/16x6x24 10 Pcs	Campus Bookstore	000216036	2	\$11.82	To make the electronics box
Art/Print/Photographic Supply (Box Cutter)	Campus Bookstore	000000074	1	\$2.68	Box-cutter to cut thicker wood
Super Glue	Campus Bookstore	000000074	1	\$6.42	To assemble parts with strength
					<b>Total</b>

<b>\$259.10</b>
-----------------



### 11 Appendix C - CAD Models

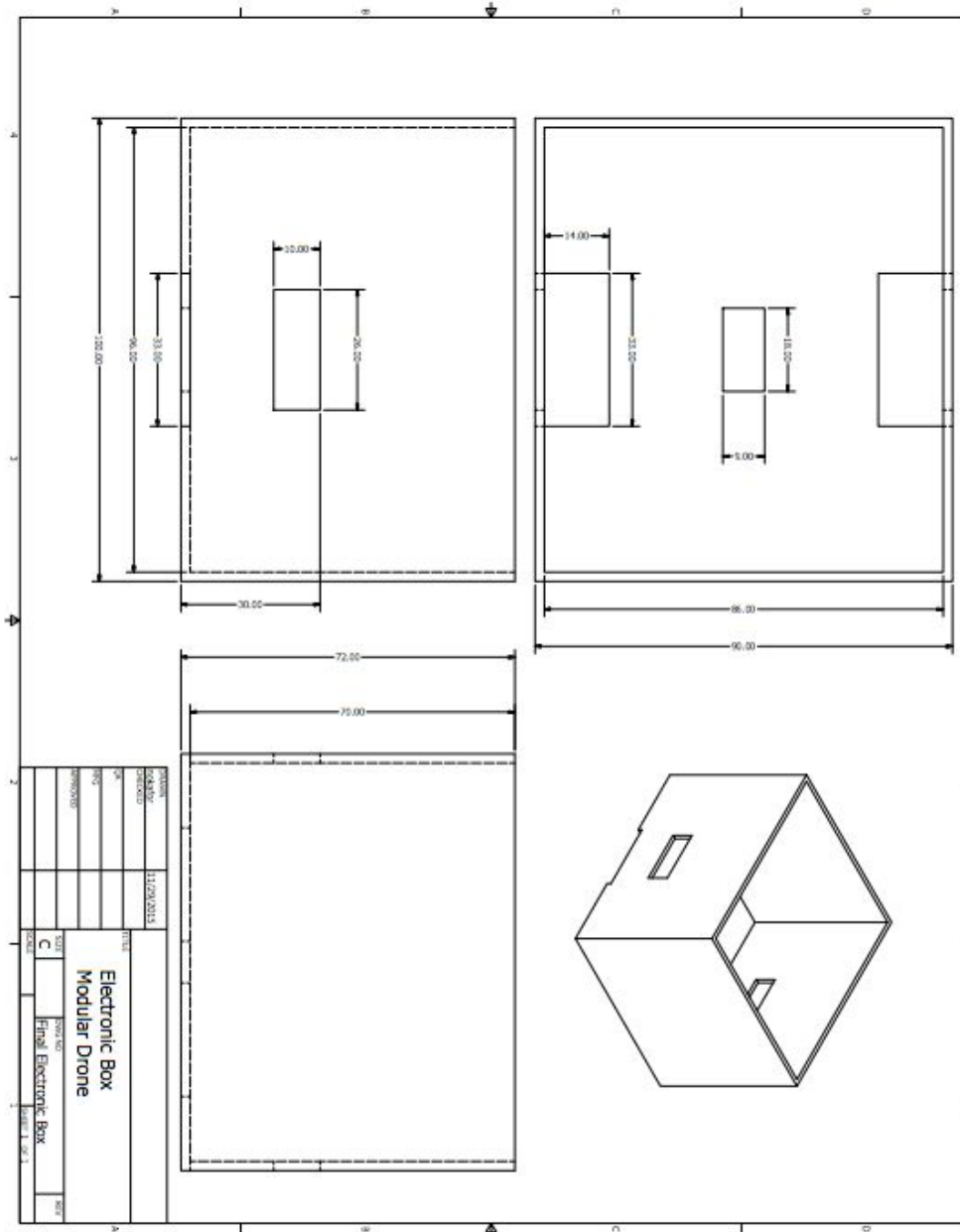

Figure 20: Electronics Box

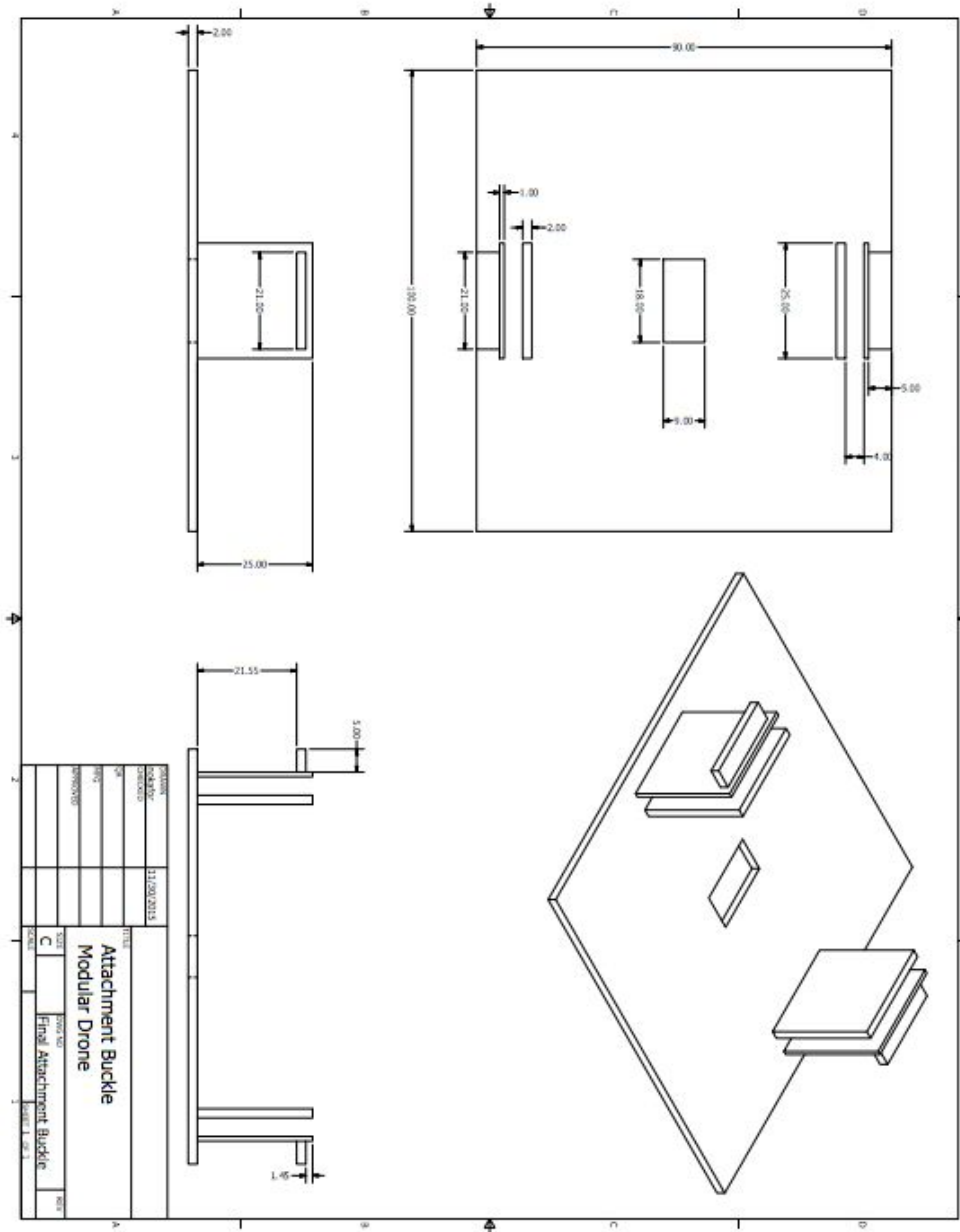

Figure 21: Attachment Buckle

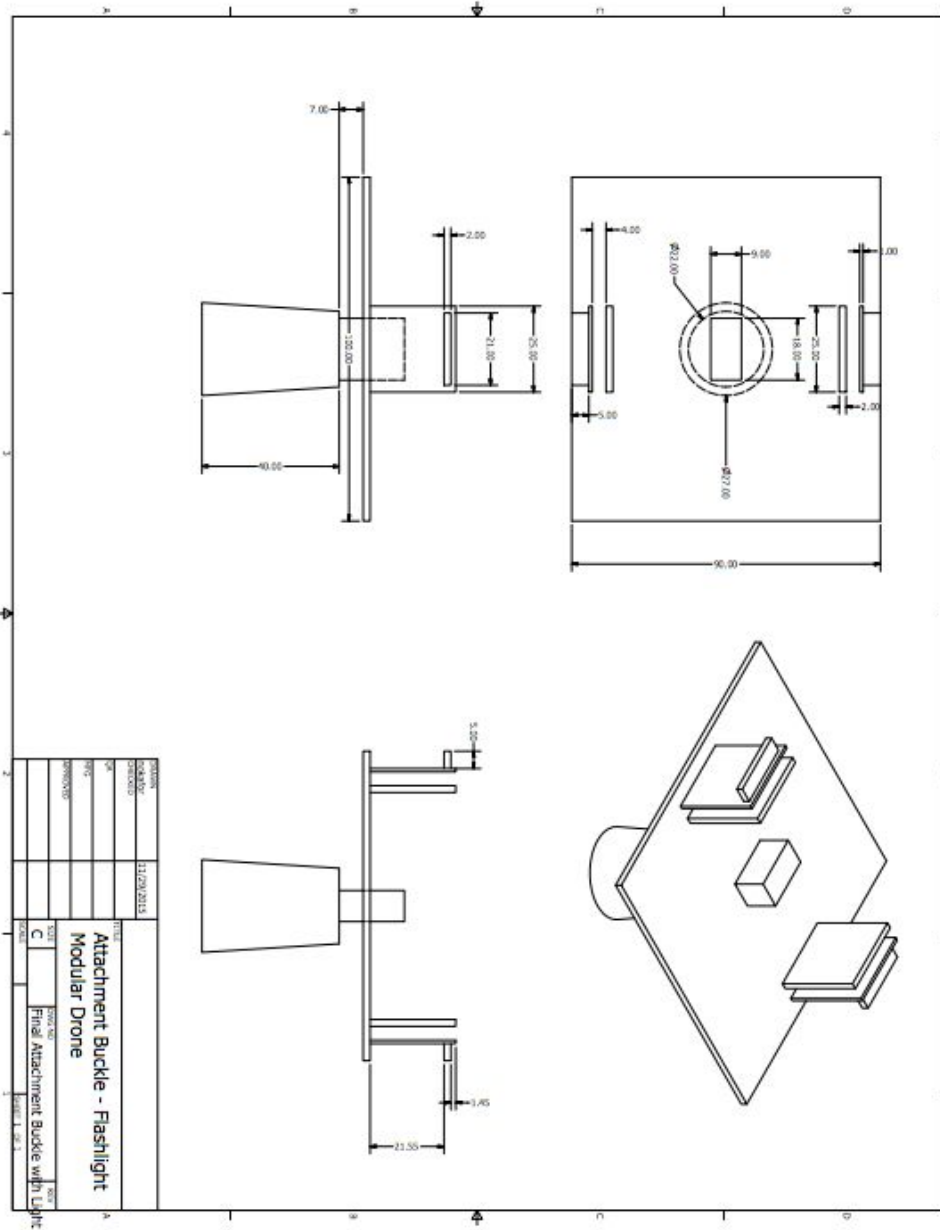

Figure 22: Attachment with Flashlight Accessory

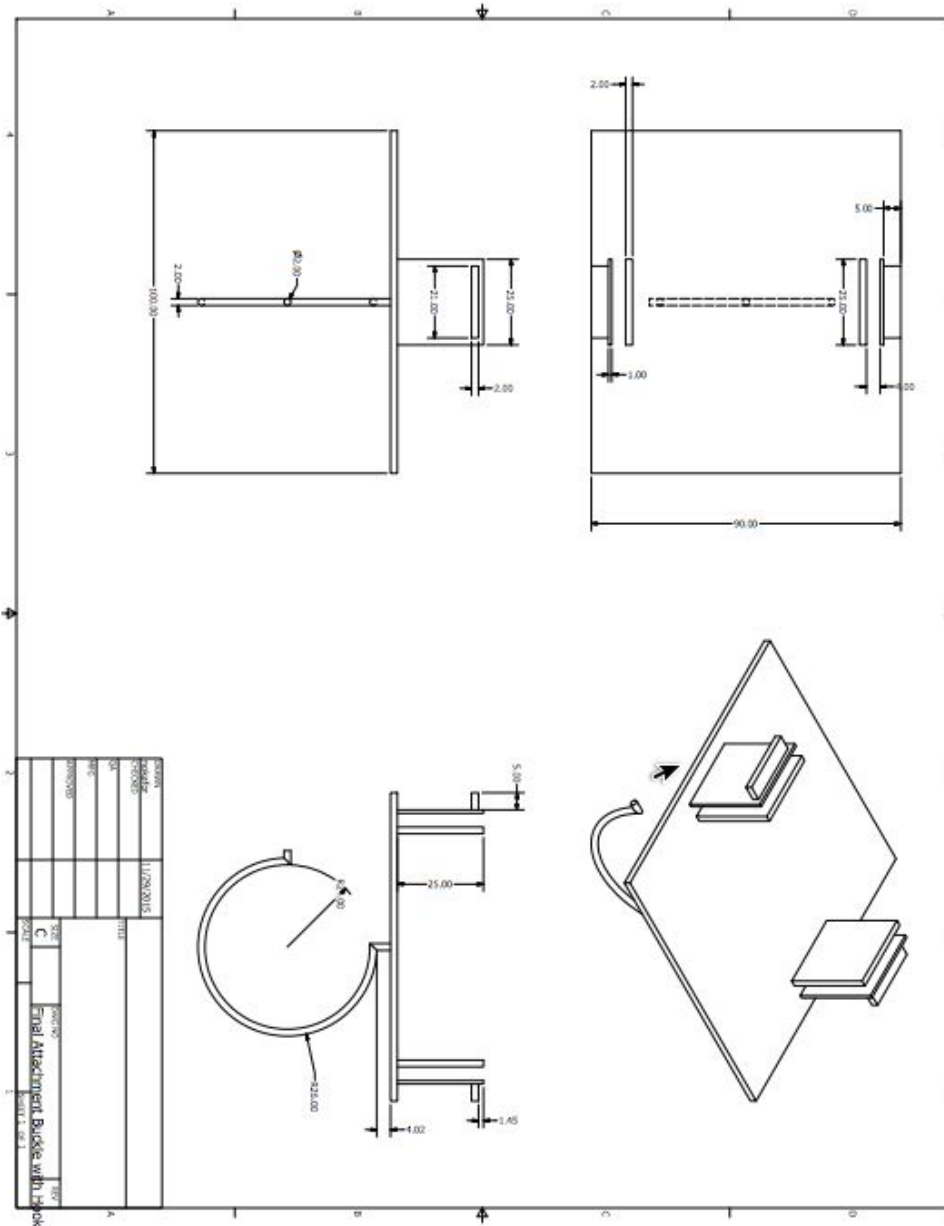

Figure 23: Attachment with Hook Accessory

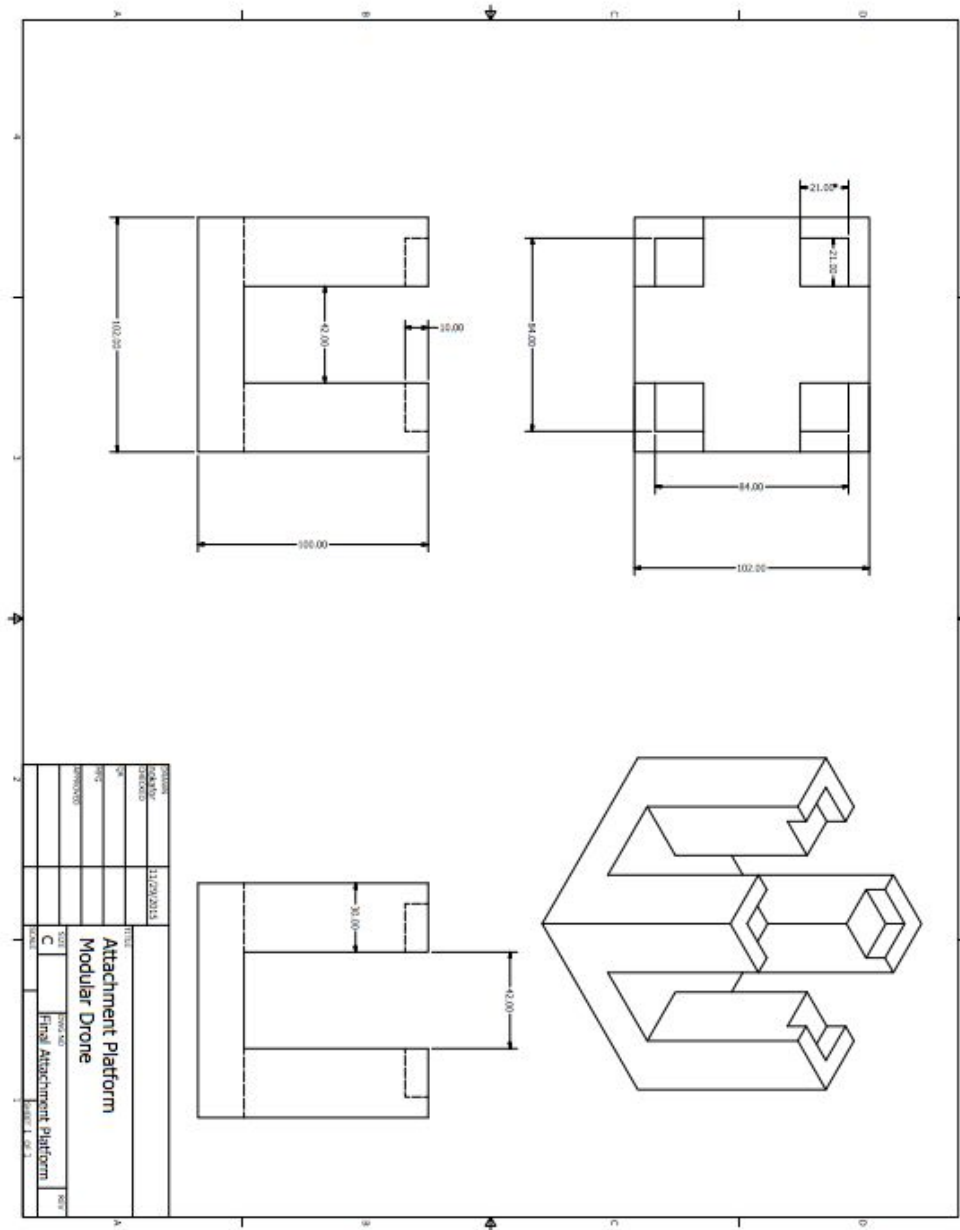

Figure 24: Attachment Platform

## 12 Annotated Bibliography

Anscher, Joseph. "Patent US5546642 - Side-release Buckle Fastener." *Google Books*. National Molding Corporation, 5 Aug. 1994. Web. 07 Dec. 2015.

<http://www.google.com/patents/US5546642>

This is the patent for the side-release buckle. This design was the main framework from which our idea was extrapolated. Branching from this, we were able to solve the modularity aspect of our drone and make sure that we could attach and detach accessories safely and securely.

"10 Best Drones 2015." *YouTube*. YouTube, n.d. Web. 07 Dec. 2015.

<https://www.youtube.com/watch?v=bUWw5xKejpo>

The "10 Best Drones 2015" video served as excellent inspiration as we went through the process of selecting the drone to purchase. We had to do an in depth review of the drones available to us online, and rated multiple based on flight capability, weight capacity, and price. From there, we were able to choose the most appropriate drone for selection that would accurately fit the needs of our senior design project.

"Top 5 Drone Inventions You Must Have." *YouTube*. YouTube, n.d. Web. 07 Dec. 2015.

[https://www.youtube.com/watch?v=\\_l6CQRHIGyg](https://www.youtube.com/watch?v=_l6CQRHIGyg).

This video, "Top 5 Drone Inventions You Must Have", allowed us to expand our own thoughts about the set capabilities a drone can have. We saw the possibilities in expansion past the traditional drone structure, and as part of our research, we identified a gap in modularity, something we chose to hone in on to specialize our attachment feature.

"Side-Release Buckle Kit by Gear Aid." *YouTube*. YouTube, n.d. Web. 07 Dec. 2015.

<https://www.youtube.com/watch?v=ILZDSgF83ug>.

This is a video which outlines the capabilities of the side release buckle. This is the design which proved the foundation for the attachment mechanism we created and expanded upon. This shows the strength capacity and versatility of the buckle, features that made it stand out as the optimum mode of connected the accessory to the drone itself.

South Asia. "Drones: What Are They and How Do They Work? - BBC News." *BBC News*. BBC News Source, 31 Jan. 2012. Web. 07 Dec. 2015. <<http://www.bbc.com/news/world-south-asia-10713898>>.

This article outlined some of the popularity and controversy surrounding drone technology. It analyzed the role it played within the US Army and how it is being utilized for warfare. Yet, it expanded past this and showcased some of the other uses for the technology, and why it has grown so popular in such a short amount of time in our society.

"What Is Drone? - Definition from WhatIs.com." *WhatIs.com*. N.p., n.d. Web. 07 Dec. 2015. <<http://whatistechtarget.com/definition/drone>>.

From this article, we were able to understand the basic definition of drones. This was what was shown to us, and helped guide us along the way to understand the technology we would be using throughout the semester. "Drones are more formally known as unmanned aerial vehicles (UAV). Essentially, a drone is a flying robot. The aircraft may be remotely controlled or can fly autonomously through software-controlled flight plans in their embedded systems working in conjunction with GPS. UAVs have most often been associated with the military but they are also used for search and rescue, surveillance, traffic monitoring, weather monitoring and firefighting, among other things."

"How I Accidentally Kickstarted the Domestic Drone Boom." *Wired.com*. Conde Nast Digital, n.d. Web. 07 Dec. 2015. <[http://www.wired.com/2012/06/ff\\_drones/](http://www.wired.com/2012/06/ff_drones/)>.

This article from Wired gave amazing insight on the drone boom of this past decade. It showed some reasons for the mass popularity it has gained over the past couple years, and how it has even outnumbered US military drones for sheer domestic purposes.