

Washington University in St. Louis

## Washington University Open Scholarship

---

Washington University / UMSL Mechanical  
Engineering Design Project JME 4110

Mechanical Engineering & Materials Science

---

Summer 2016

### JME 4110 Portable Diaper Changing Table

Dan J. Suda

*University of Missouri-St. Louis, djsuda93@gmail.com*

Brandon Bequette

*University of Missouri-St. Louis, brandonbequette@go.wustl.edu*

Arber Kume

*University of Missouri-St. Louis, arberkume@gmail.com*

Sam Bender

*University of Missouri-St. Louis, sbender@wustl.edu*

Follow this and additional works at: <https://openscholarship.wustl.edu/jme410>

---

#### Recommended Citation

Suda, Dan J.; Bequette, Brandon; Kume, Arber; and Bender, Sam, "JME 4110 Portable Diaper Changing Table" (2016). *Washington University / UMSL Mechanical Engineering Design Project JME 4110*. 6. <https://openscholarship.wustl.edu/jme410/6>

This Final Report is brought to you for free and open access by the Mechanical Engineering & Materials Science at Washington University Open Scholarship. It has been accepted for inclusion in Washington University / UMSL Mechanical Engineering Design Project JME 4110 by an authorized administrator of Washington University Open Scholarship. For more information, please contact [digital@wumail.wustl.edu](mailto:digital@wumail.wustl.edu).



Joint Engineering Program

University of Missouri–St. Louis ■ Washington University in St. Louis

ELEVATE YOUR FUTURE.  
ELEVATE ST. LOUIS.

---

# JME 4110 Design Report Title

---

## Portable Diaper Changing Table

---

Dan Suda, Brandon Bequette,  
Arber Kume, Sam Bender

---

Our project combines a diaper bag, portable changing table and a bassinet all in one. This product is for any new mothers and fathers with an infant baby. The purpose of this product is to make it easier on the parent by having an all in one carrying case that easily folds into a changing table all while holding your baby in one arm.

List of Figures .....	3
List of Tables .....	4
1. Introduction	5
1.1. Value proposition / project suggestion	5
1.2. List of team members	5
2. Background Information Study	5
2.1. A short design brief description that describes the design problem	5
2.2. Summary of relevant background information (such as similar existing devices or patents, patent numbers, URL's, et cetera)	5
3. Concept Design and Specification	5
3.1. User needs, metrics, and quantified needs equations.	5
3.1.1. Record of the user needs interview	5
3.1.2. List of identified metrics	5
3.1.3. Table/list of quantified needs equations	5
3.2. Four (4) concept drawings	5
3.3. A concept selection process.	5
3.3.1. Concept scoring (not screening)	5
3.3.2. Preliminary analysis of each concept's physical feasibility	5
3.3.3. Final summary statement	5
3.4. Proposed performance measures for the design	5
3.5. Revision of specifications after concept selection	5
4. Embodiment and fabrication plan	5
4.1. Embodiment/Assembly drawing	5
4.2. Parts List	5
4.3. Draft detail drawings for each manufactured part	5
4.4. Description of the design rationale for the choice/size/shape of each part	6
5. Engineering analysis	6
5.1. Engineering analysis proposal	6
5.1.1. Signed engineering analysis contract	6

5.2.		Engi
neering analysis results		6
5.2.1.	Motivation	6
5.2.2.	Summary statement of analysis done	6
5.2.3.	Methodology	6
5.2.4.	Results	6
5.2.5.	Significance	6
6.	Risk Assessment	6
6.1.	Risk Identification	7
6.2.	Risk Analysis	7
6.3.	Risk Prioritization	7
7.	Codes and Standards	8
7.1.	Identification	8
7.2.	Justification	8
7.3.	Design Constraints	8
7.3.1.	Functional	8
7.3.2.	Safety	8
7.3.3.	Quality	8
7.3.4.	Manufacturing	8
7.3.5.	Timing	8
7.3.6.	Economic	8
7.3.7.	Ergonomic	8
7.3.8.	Ecological	8
7.3.9.	Aesthetic	8
7.3.10.	Life cycle	8
7.3.11.	Legal	8
7.4.	Significance	8
8.	Working prototype	8
8.1.		At
least two digital photographs showing the prototype		8
8.2.		A
short video clip that shows the final prototype performing		8
8.3.		At
least four additional digital photographs and their explanations		8

9. Design documentation	8
9.1.	Final
1 Drawings and Documentation	8
9.1.1. A set of engineering drawings that includes all CAD model files and all drawings derived from CAD models. Include units on all CAD drawings. See Appendix C for the CAD models.	8
9.1.2. Sourcing instructions	9
9.2.	Final
1 Presentation	9
9.2.1. Link to the video presentation	9
10. Teardown	9
11. Appendix A - Parts List	9
12. Appendix B - Bill of Materials	9
13. Annotated Bibliography	9

**LIST OF FIGURES**

<a href="#">Figure 1: Use insert object to insert a PowerPoint slide. Right click on object to add caption.</a>	3
<a href="#">Figure 2: Use insert object to insert an image. Right click on image to insert a caption.</a>	3
<a href="#">Figure 3: Insert a chart using insert object. Right click on object to add caption.</a>	3

**LIST OF TABLES**

<a href="#">Table 1: Excel worksheet</a>	3
<a href="#">Table 2: Word table of values</a>	3

## **1. INTRODUCTION**

### **1.1. VALUE PROPOSITION / PROJECT SUGGESTION**

Our proposition for this design will target a specific group of consumers, mothers and fathers, which are looking for a cost effective baby changer. The design will be focused on portability, durability and low cost factor. In this design we will focus on a large number of parents who often rely on public transportation and cannot rely on public restroom baby changers. This scenario factors in the probability of the absence of baby changing tables inside public restrooms. A portable baby changing will allow a parent to take their time to shop for better product due to freeing them from establishments which offer changing stations in public restrooms, thus giving a parent a greater radius to travel to shop for more cost effective consumer goods. Moreover the table will be able to be shoulder carried and offer light weight.

## **1.2. LIST OF TEAM MEMBERS**

Dan Suda, Brandon Bequette, Arber Kume, Sam Bender

## **2. BACKGROUND INFORMATION STUDY**

### **2.1. A SHORT DESIGN BRIEF DESCRIPTION THAT DESCRIBES THE DESIGN PROBLEM**

- For mothers & fathers who are nurturing their first born and need an affordable changing table.
- Who are dissatisfied with the lack of changing tables at Target stores, where they often shop for dippers, baby food and other products.
- Our product is a new alternative which offers a low cost solution and portability.
- This provides less dependency on stores with/without changing tables.
- Unlike the static changing tables, this one is portable and can be taken everywhere.

**2.2. SUMMARY OF RELEVANT BACKGROUND INFORMATION (SUCH AS SIMILAR EXISTING DEVICES OR PATENTS, PATENT NUMBERS, URL'S, ET CETERA)**

- Collapsible and portable baby changing table

Legal status Active, expires 2028-01-30

Application number US11863154

Inventor [Carmelina Hall](#)

Original Assignee [Carmelina Hall](#)

Priority date [2006-09-27](#)

Filing date [2007-09-27](#)

Publication date 2010-03-23

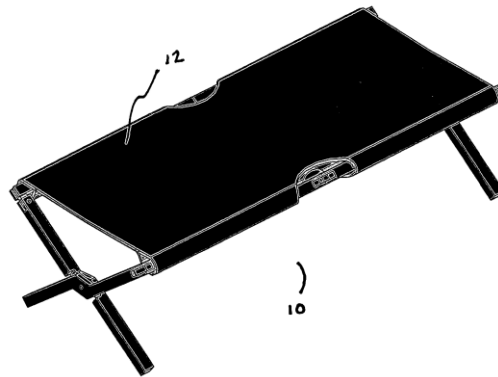
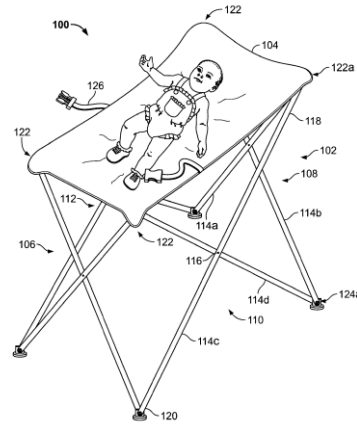

- Portable diaper changing cot (Patent #: US 20060174415 A1)



### 3. CONCEPT DESIGN AND SPECIFICATION

#### 3.1. USER NEEDS, METRICS, AND QUANTIFIED NEEDS EQUATIONS.

##### 3.1.1. Record of the user needs interview

Need Number	Need	Importance
1	One handed operation	5
2	Light weight	4
3	Removable bag	1
4	Easy to clean material	4
5	Cost less than \$100	5
6	Easy to carry	4
7	Able to support weight of baby	5
8	Able to protect baby from rolling off	4
9	Length is less than 30 inches	3
10	Not too bulky	3
11	Able to carry on back	1

**3.1.2. List of identified metrics**

Metric Number	Associated Needs	Metric	Units	Min Value	Max Value
1	10, 11	Length	in	0	24
2	11	Width	in	0	15
3	11	Height	in	0	18
4	2, 7, 11	Weight	Pounds	0	15
5	9	Safety Strap	Integer	0	1
6	3, 12	Portability	Binary	0	1
7	5	Cost	Dollars	0	100
8	7	Ergonomic	Binary	0	1
9	4, 6	Cleaning	Binary	0	1
10	3, 6	Ease of Use	Binary	0	1
11	8	Strength	Binary	0	1
12	9	Roll Off Guard	Integer	0	1
13	12	Shoulder Strap	Integer	0	1

3.1.3. Table/list of quantified needs equations

Briefcase Changing Table		Metric												Need Happiness	Importance Weight (all entries should add up to 1)	Happiness	
Need#	Need	length	width	height	weight	safety strap	portability	cost	ergonomics	cleaning	ease of use	strength	roll off guards				shoulder straps
		1	2	3	4	5	6	7	8	9	10	11	12	13			
1	one handed operation										1				0	0.1	
2	light weight				1										0.33	0.1	0.033
3	removable bag														0	0.025	0
3	easy to clean material									1					0	0.1	0
4	cost less than \$100							1							0.9	0.1	0.09
5	quick cleaning									0.5	0.5	0.5			0	0.1	0
6	easy to carry				0.5				0.5						0.165	0.1	0.0165
7	able to support weight of baby												1		1	0.1	0.1
8	able to protect baby from rolling off					1									1	0.1	0.1
9	length is less than 30 inches	1													0.25	0.1	0.025
10	not too bulky	0.3	0.3	0.3	0.1										0.387	0.05	0.01935
11	able to carry on back						1								1	0.025	0.025
	Units	inches	inches	inches	pounds	integer	binary	dollars	binary	binary	binary	binary	integer	integer	Total Happiness		0.40885
	Best Value	0	0	0	0	1	1	0	1	1	1	1	3	2			
	Worst Value	24	15	18	15	0	0	100	0	0	0	0	0	0			
	Actual Value	18	6	12	10	1	1	100	0	0	0	1	3	1			
	Normalized Metric Happiness	0.25	0.6	0.33	0.33	1	1	0.9	0	0	0	1	3	0.5			

Cot Changing Table		Metric													Need Happiness	Importance Weight (all entries should add up to 1)	Happiness
		length	width	height	weight	safety strap	portability	cost	ergonomics	cleaning	ease of use	strength	roll off guards	shoulder straps			
Need#	Need	1	2	3	4	5	6	7	8	9	10	11	12	13			
1	one handed operation											1					1
2	light weight				1												0.33
3	removable bag																0
4	easy to clean material									1							0
5	cost less than \$100							1									0.9
6	quick cleaning									0.5		0.5					0.5
7	easy to carry				0.5					0.5							0.665
8	able to support weight of baby												1				1
9	able to protect baby from rolling off						1										1
10	length is less than 30 inches	1															0.25
11	not too bulky	0.3	0.3	0.3	0.1												0.387
12	able to carry on back							0.5								0.5	1
Units		inches	inches	inches	pounds	integer	binary	dollars	binary	binary	binary	binary	integer	integer			Total Happiness
Best Value		0	0	0	0	1	1	0	1	1	1	1	1	3	2		
Worst Value		24	15	18	15	0	0	100	0	0	0	0	0	0	0		
Actual Value		18	6	12	10	1	1	100	1	1	1	1	1	3	2		
Normalized Metric Happiness		0.25	0.6	0.33	0.33	1	1	0.9	1	0	1	1	1	1	1		0.50885

Diaper Bag Combo		Metric													Need Happiness	Importance Weight (all entries should add up to 1)	Total Happiness Value
		length	width	height	weight	safety strap	portability	cost	ergonomics	cleaning	ease of use	strength	roll off guards	shoulder straps			
Need#	Need	1	2	3	4	5	6	7	8	9	10	11	12	13			
1	one handed operation											1					1
2	light weight				1												0.33
3	removable bag							0.5									1
4	easy to clean material									1							1
5	cost less than \$100							1									0.9
6	quick cleaning									0.5		0.5					1
7	easy to carry				0.5					0.5		0.5					0.665
8	able to support weight of baby												1				1
9	able to protect baby from rolling off						1										1
10	length is less than 30 inches	1															0.25
11	not too bulky	0.3	0.3	0.3	0.1												0.387
12	able to carry on back							0.5								0.5	1
Units		inches	inches	inches	pounds	integer	binary	dollars	binary	binary	binary	binary	integer	integer			Total Happiness
Best Value		0	0	0	0	1	1	0	1	1	1	1	1	3	2		
Worst Value		24	15	18	15	0	0	100	0	0	0	0	0	0	0		
Actual Value		18	6	12	10	1	1	100	1	1	1	1	1	3	2		
Normalized Metric Happiness		0.25	0.6	0.33	0.33	1	1	0.9	1	1	1	1	1	1	1		0.6776

Diaper Bag Attachment Changing Table		Metric													Need Happiness	Importance Weight (all entries should add up to 1)	Total Happiness Value
		length	width	height	weight	safety strap	portability	cost	ergonomics	cleaning	ease of use	strength	roll off guards	shoulder straps			
Need#	Need	1	2	3	4	5	6	7	8	9	10	11	12	13			
1	one handed operation											1					1
2	light weight				1												0.33
3	removable bag																0
4	easy to clean material									1							1
5	cost less than \$100							1									0.9
6	quick cleaning									0.5		0.5					1
7	easy to carry				0.5					0.5		0.5					0.165
8	able to support weight of baby												1				1
9	able to protect baby from rolling off						0.5							0.5			1
10	length is less than 30 inches	1															0.25
11	not too bulky	0.3	0.3	0.3	0.1												0.387
12	able to carry on back							0.5								0.5	1
Units		inches	inches	inches	pounds	integer	binary	dollars	binary	binary	binary	binary	integer	integer			Total Happiness
Best Value		0	0	0	0	1	1	0	1	1	1	1	1	3	2		
Worst Value		24	15	18	15	0	0	100	0	0	0	0	0	0	0		
Actual Value		18	6	12	10	1	1	100	0	1	1	1	1	3	2		
Normalized Metric Happiness		0.25	0.6	0.33	0.33	1	1	0.9	0	1	1	1	1	1	1		0.6085

### 3.2. FOUR (4) CONCEPT DRAWINGS

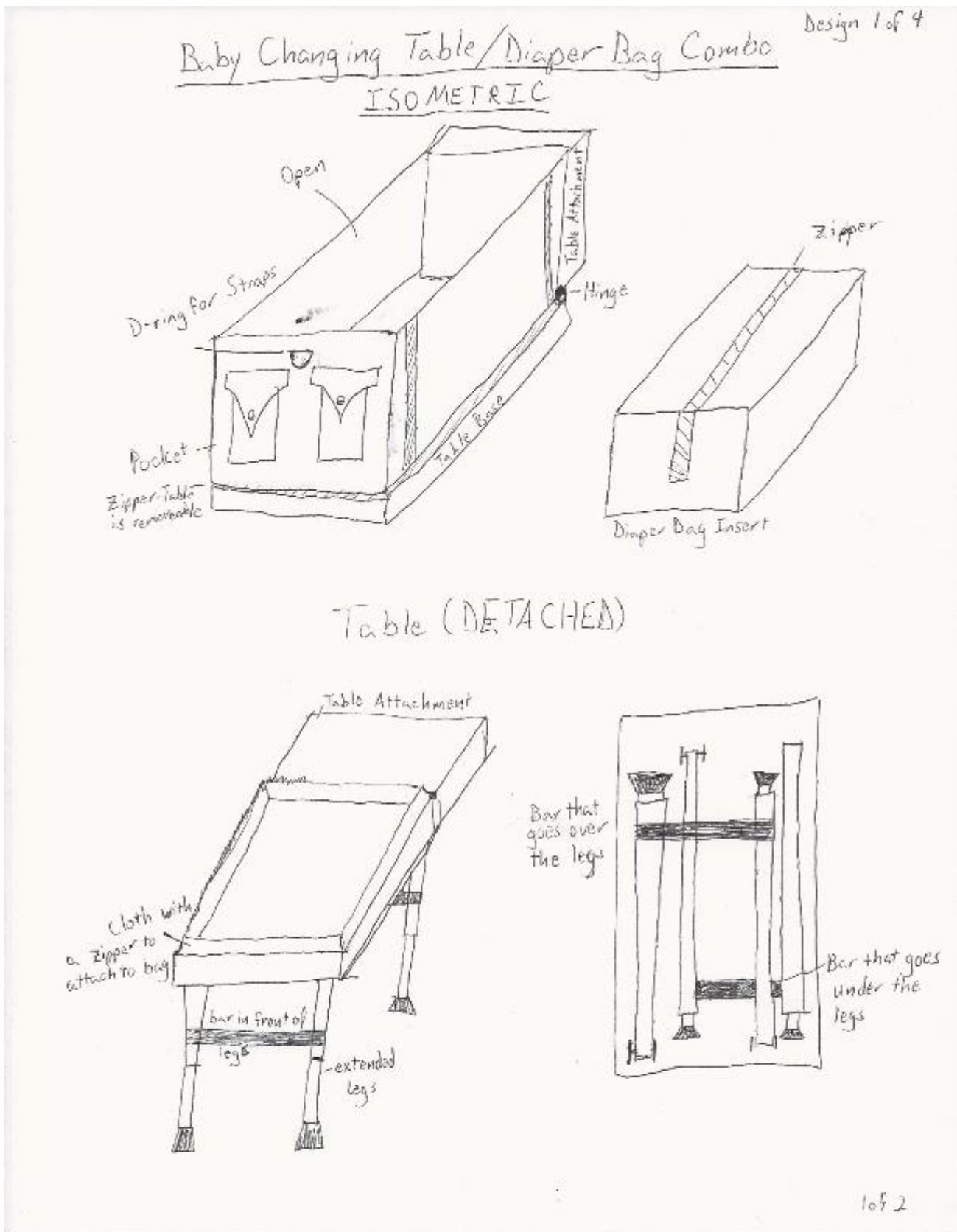

### Baby Changing Table: Diaper Bag Attachment

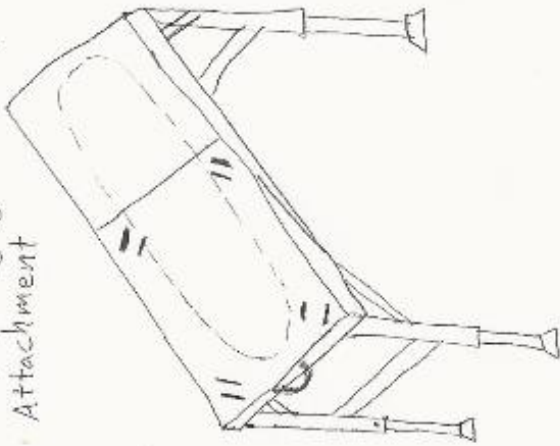

- Telescoping legs that when closed, can fold into each half of the table. Made of steel or possibly aluminum. 17" closed, 34" open.
- Table top consists of plastic material with indent to hold baby. The indent keeps the baby from rolling off the table. Bag 13" wide, 17" long, 34" unfolded.
- Slots cut into one side of the table for straps used to attach the table to the bottom of a diaper bag.
- Removable from diaper bag for easier cleanup.

### Design 2 of 4

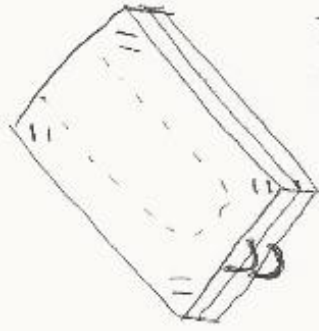

- When folded, can be attached using system of straps to the bottom of a diaper bag.
- Locks in the closed position or open.
- Legs are fully concealed when table is in the closed position.
- Handles attached to the edge of table in case you want to transport it another way.
- 3" high when closed.
- Easy to open one handed, if not timely.

\*Dimensions and materials subject to change.

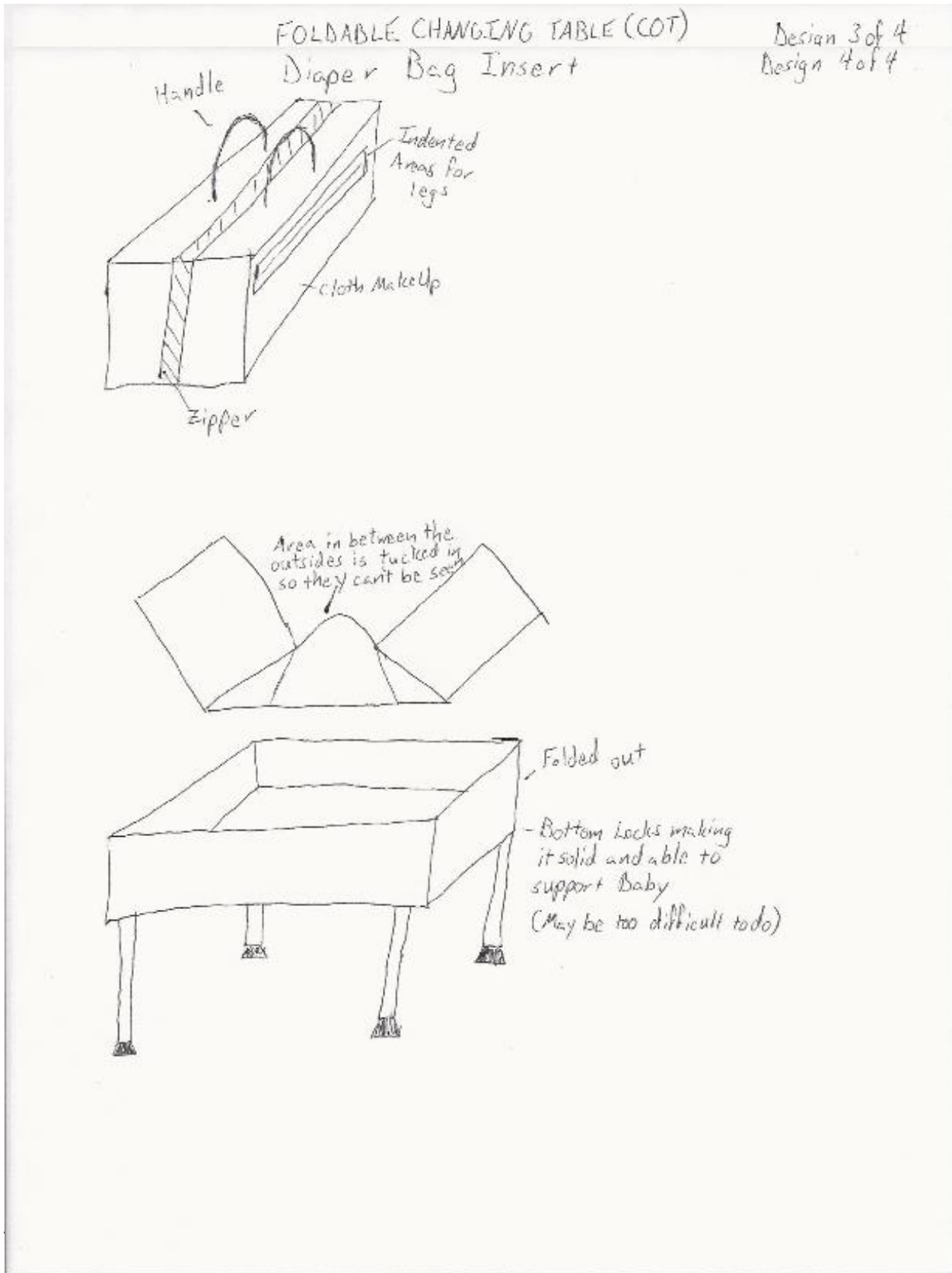

### **3.3. A CONCEPT SELECTION PROCESS.**

#### **3.3.1. Concept scoring (not screening)**

After filling out the quantified needs equation tables we see that the diaper bag combo yields the greatest total happiness value. This is because it is a more functional and ergonomic product than the other options. The diaper bag has a 0.07 higher value than the second best option and a 0.25 value higher than the worst option. The total happiness value for the diaper bag combo is 0.67, but it could be better.

#### **3.3.2. Preliminary analysis of each concept's physical feasibility**

The briefcase changing table is feasible, but would be difficult to construct and is also bulky. The cot changing table is feasible but wouldn't be able to withstand the weight of a baby especially if the legs were long and skinny. The diaper bag combo is feasible but seems like extensive work to fashion them together. For the last concept, a diaper bag attachment would be easily made.

#### **3.3.3. Final summary statement**

We chose to go with the baby changing table with a diaper bag attached for the reason of portability and marketability. One version of the baby changing table was portable with a carrying bag, but is not as marketable because of the multi-use aspect of having a changing table and diaper bag all in one. We had discussed another type of table that had hooks for hanging, but it was decided that it was not practical in many situations where there is no place to hang the changing table. One of our designs showed a folding baby changing table that was easily portable, but again, not as marketable as the changing table with diaper bag attached. The diaper



bag and changing table combo is the most marketable and easily portable with a carrying handle and shoulder straps.

### **3.4. PROPOSED PERFORMANCE MEASURES FOR THE DESIGN**

The primary performance measure for the design is to provide a portable diaper bag & changing table all in one. One important feature we would like is for the product to be deployed and retracted using a one handed operation. We want it to be light weight, compact, and strong enough to support the heaviest of babies. We want it to be easily cleanable and also cheap.

### **3.5. REVISION OF SPECIFICATIONS AFTER CONCEPT SELECTION**

It seems that the overall performance measure is ease of use and portability. This was determined during the user needs interview and survey. The baby changing table and diaper bag combo needs to be able to be carried on the back like a backpack or carried in a stroller. The diaper bag with changing table attached will include shoulder straps for carrying on the back and be small enough to be carried in the lower carrying compartment of a baby stroller. During the user needs interview we found out that ease of use was very important and that one handed operation was desirable. The specifications that changed were those of privacy. We had originally thought that privacy was an important issue and discovered during the needs interview that it is not that important.

## **4. EMBODIMENT AND FABRICATION PLAN**

### **4.1. EMBODIMENT/ASSEMBLY DRAWING (ORIGINAL DESIGN)**

# Baby Changing Table/Diaper Bag Combo

## ISOMETRIC

Design 1 of 4

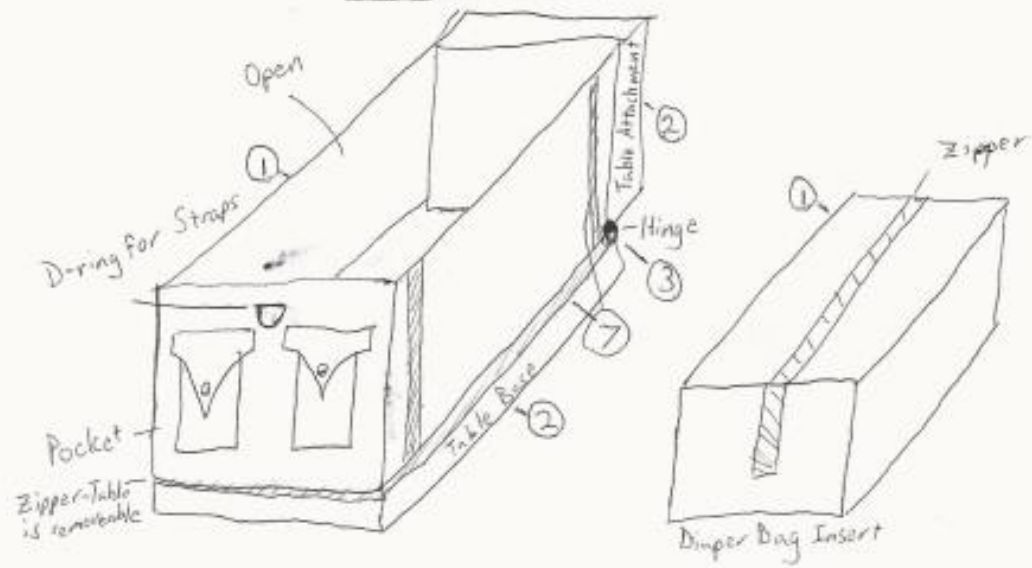

## Table (DETACHED)

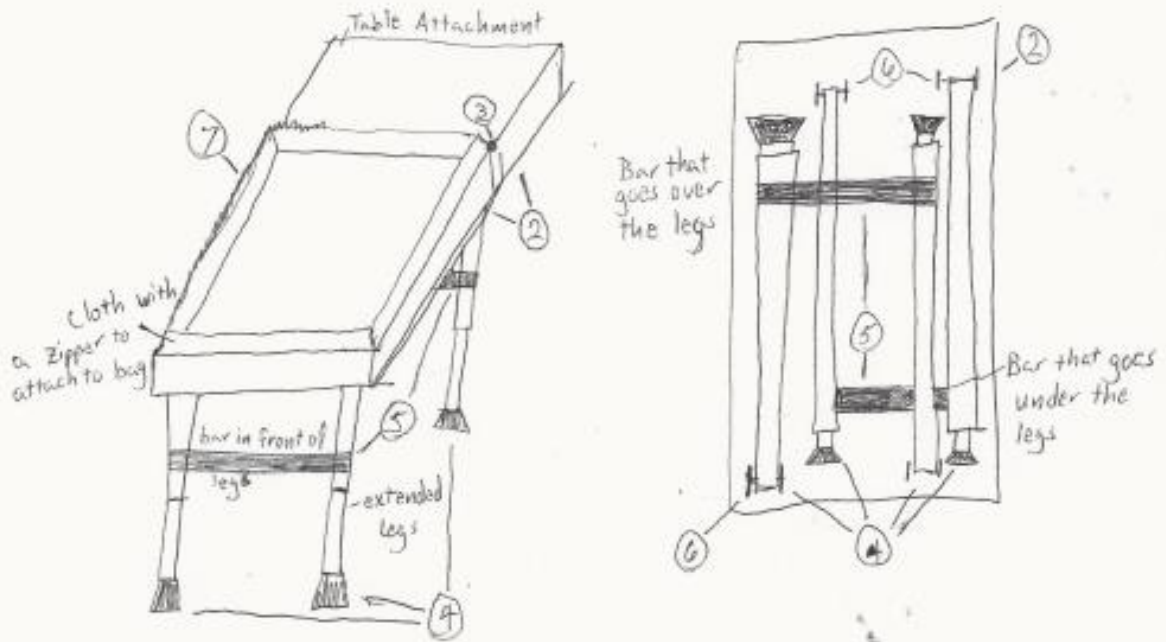

Design 1 of 4

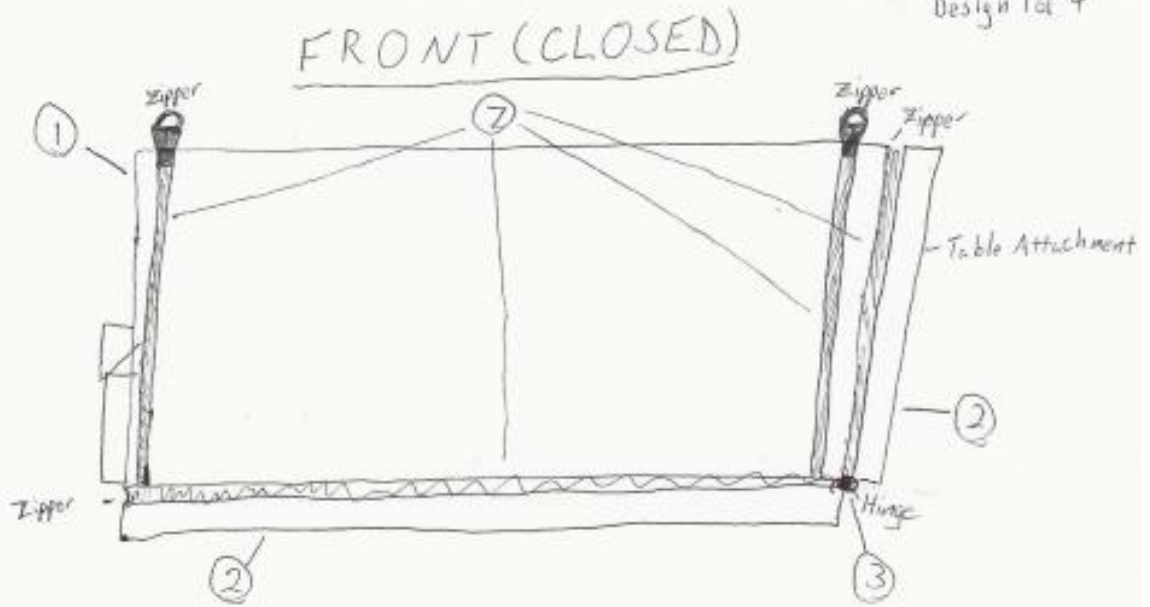

FRONT (OPEN)

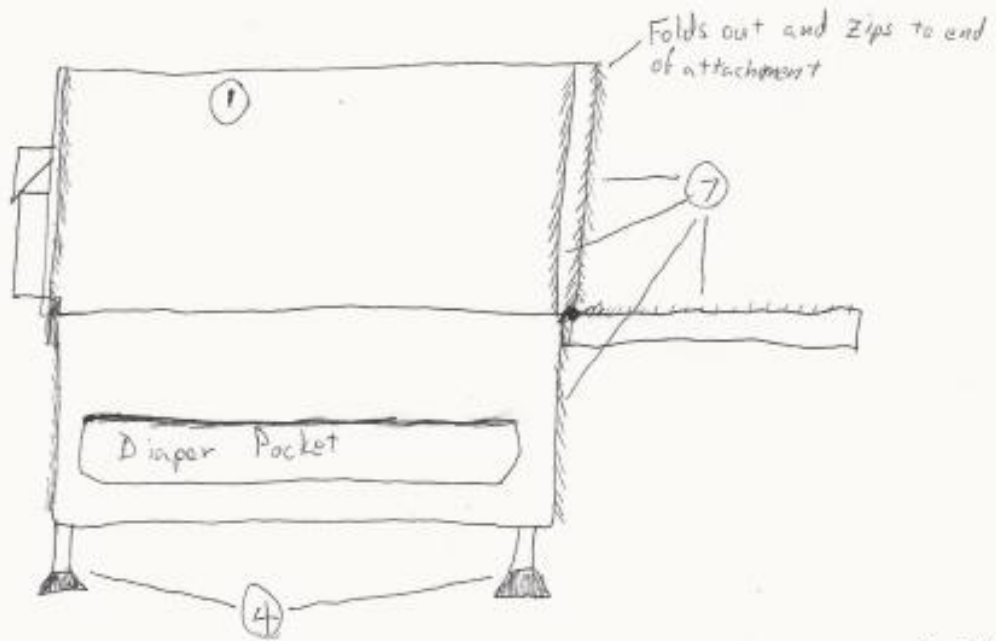

2 of 2

#### 4.2. PARTS LIST (ORIGINAL DESIGN)

Part #	Part	Where It Came From	Price Per Item	Quantity	Total
1	Range Bag w/ insert	Midway USA	\$39.99	1	\$39.99
2	Plastic Sheet .25"*54"*24"	ePlastics.com	\$36.14	1	\$36.14
3	Hinge 3.5" 3 Pack	Lowes	\$2.78	2	\$5.56
4	Adjustable Table Legs 36"	Amazon	\$15.38	4	\$61.52
5	1/2" Half- Round Al Rod	McMaster	\$6.73	1	\$6.73
6	Hardware to Attach Legs	Machine Shop	0	4	\$0.00
7	One-Way Sep. Zipper Tape	Seattle Fabrics	\$8.50	2	\$17.00

#### 4.3. PARTS LIST

- Diaper bag and changing station combo
- 2' by 3' piece of hard plastic 1/4" thick
- Collapsible and actuating leg system
- Fasteners to fasten legs to plastic
- 1" wide straps to fasten diaper bag to plastic



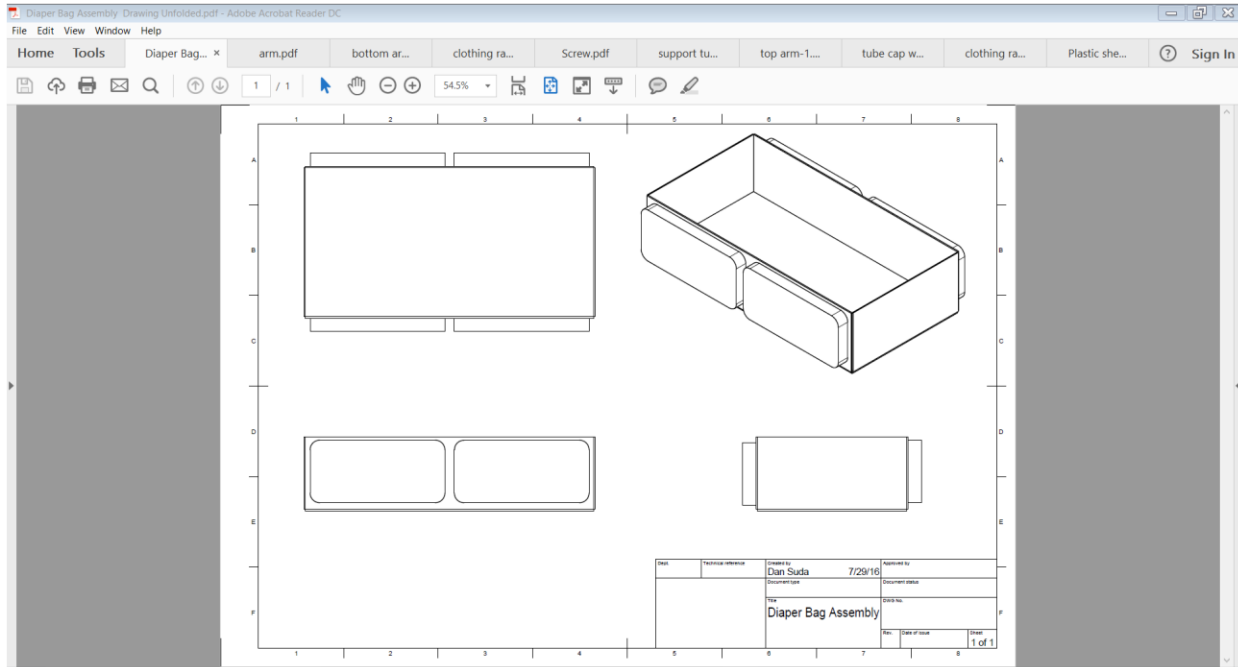

3. Diaper Bag

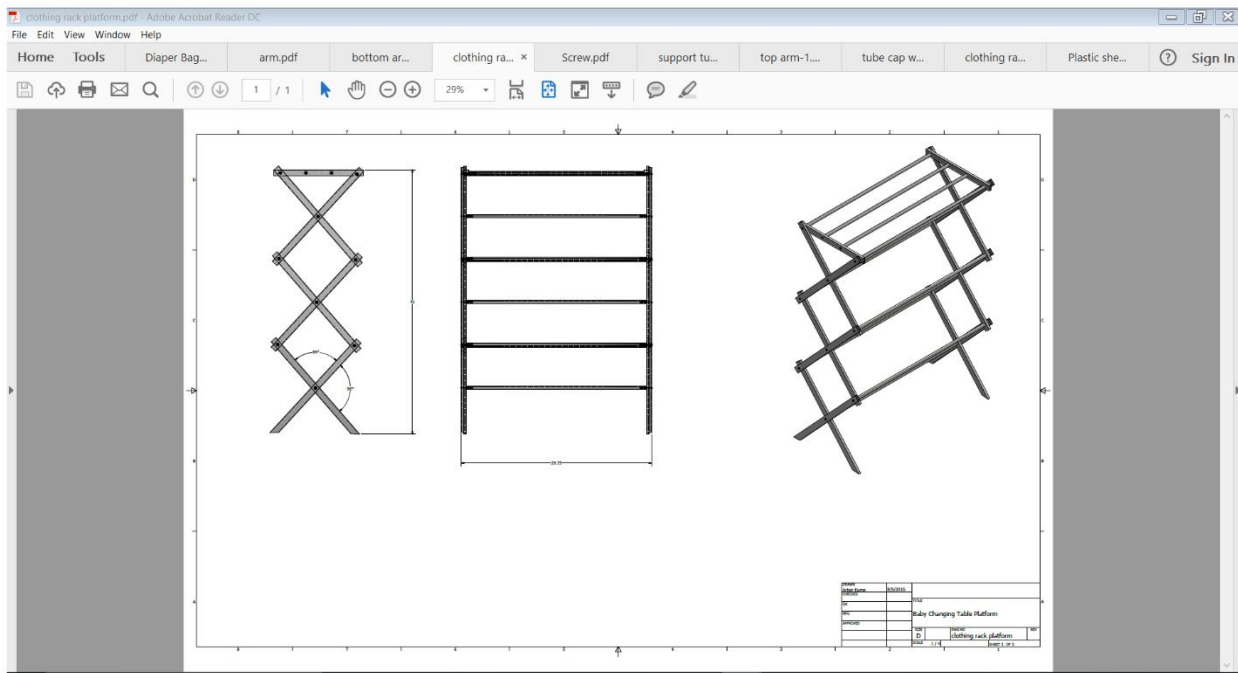

4. Scissor Platform

#### 4.5. DESCRIPTION OF THE DESIGN RATIONALE FOR THE CHOICE/SIZE/SHAPE OF EACH PART

We decided to make a stable, light weight, and portable baby changing table. We wanted to make it around 36" high so that our customers would not have to bend over to change their

child. We thought it best to make it stationary when deployed to decrease the risk of collapse and dropping the baby. Already in possession of a baby bassinet, we ordered a prefabricated towel rack that matched the bottom of said bassinet. The towel rack is light weight, has easy setup and take down, stable, and was not difficult to attach to the bassinet.

## 5. ENGINEERING ANALYSIS

### 5.1. ENGINEERING ANALYSIS PROPOSAL

MEMS 411 / JME 4110  
MECHANICAL ENGINEERING DESIGN PROJECT

ASSIGNMENT 5: Engineering analysis task agreement (2%)

ANALYSIS TASKS AGREEMENT

PROJECT: *Portable Infant Diaper Changer* NAMES: *Don Suda (DS)* INSTRUCTOR: *Dr. Jakiela*  
*Sam Bender (SB)*  
*Arber Kume*  
*Brandon Bequette (BB)*

The following engineering analysis tasks will be performed:

*Load Calculation on legs*

The work will be divided among the group members in the following way:  
*Don, Sam, Brandon will work on assembling diaper bag and purchased legs.*  
*Arber will fabricate a set of legs*

Instructor signature: *Manoj Jakiela*; Print instructor name: JAKIELA

(Group members should initial near their name above.)

#### 5.1.1. Signed engineering analysis contract

## **5.2. ENGINEERING ANALYSIS RESULTS**

### **5.2.1. Motivation**

Our product will consist of 2 main connections. One connection is between the metal leg system and the plastic buffer. This will likely be done by drilling holes through both materials and using a bolt and nut to secure them together. The next connection is between the plastic buffer and the diaper bag. We can connect them by glue or rivets, etc. The most important aspects currently in the project is how the leg system will work and how it will be stored when collapsed. Other important things are making sure the entire system is stable and secure when in use, like making sure it isn't top heavy.

### **5.2.2. Summary statement of analysis done**

The most significant force that will be applied to our product will be a baby's weight. It should also be able to support an adult pushing down on it some just in case. The average 18 month old baby weighs about 30 pounds, and ideally we would like a safety factor of around 2. That means that the product should support a 60 lb load. If we have 4 legs supporting the diaper changing table, each leg would carry about 15lbs which is definitely do-able.

### **5.2.3. Methodology**

We did not conduct any experimentation to complete our analysis, it was purely computational. We built a prototype leg system but dropped the idea after seeing how the legs would sit when they were closed/folded up.

### **5.2.4. Results**

The results of our analysis study are that we still have some major decision making to do, but when we do figure it out we will be close to being completed with the project. Once we get the



purchases that we are making online, we will get a better idea of how everything will be put together.

### **5.2.5. Significance**

The results influenced the final prototype by ruling out one leg system version. The dimensions for the legs will have to be small in diameter and made of aluminum. We don't want the legs to be bulky in diameter and aluminum is light but could still support the type of load we will be dealing with.

## **6. RISK ASSESSMENT**

### **6.1. RISK IDENTIFICATION**

- Suppliers
- Staff
- Health and Safety
- IT
- Contracts

Plot of Probability Vs. Impact

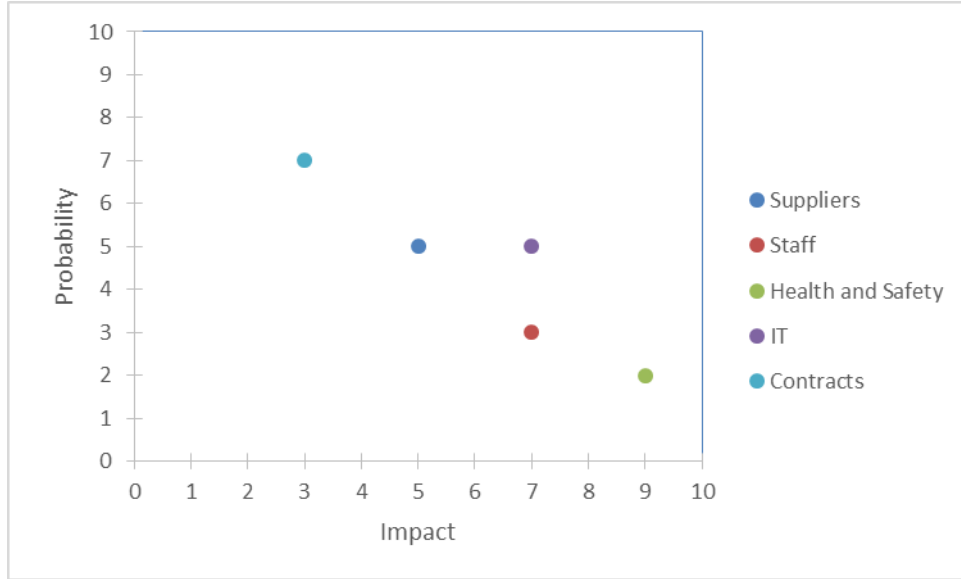

## 6.2. RISK ANALYSIS

Risk Area	Risk Description	Probability	Impact	Risk Classification	Responsibility
Suppliers	Loss of Suppliers	Medium	Medium	Routine	Chief Financial Officer
Staff	Loss of Key Staff	Low	High	Difficult	Chief Human Resources Officer
Health and Safety	Significant Workplace Accident	Low	High	Difficult	Safety Manager
IT	Power Outage or Server Crash	Medium	High	Critical	IT Manager
Contracts	Loss of Contracts	High	Low	Routine	Operations Manager

## 6.3. RISK PRIORITIZATION

**Mitigating Actions:**

Suppliers- Keep an updated list of alternate suppliers of materials needed for our manufacturing process

Staff- Keep job applications on file and identify recruitment agencies

Health and Safety- Educate workers on safe practices and report all accidents

IT- Ensure that all data gets backed-up to off site server

Contracts- Ensure all contracts are completed and shipped on time

**Contingency Assessment:**

Performance- Promise ten percent less than manufacturing can produce

Funding- Commit resources only when funding is assured

Timescale- Quote one week later completion dates than necessary to allow for things that may go wrong

Cost- Forecast five percent higher cost than expected to allow for mishaps

## **7. CODES AND STANDARDS**

### **7.1. IDENTIFICATION**

- 2009 ICC A117.1, Accessible and Usable Buildings and Facilities
- ASTM F 2285-04 Standard Safety Performance Specification for Diaper Changing Tables for Commercial Use
- ANSI Z535.4 Product Safety Signs and Labels

- EN 12221:2008 Changing units for domestic use. Safety Requirements
- ASTM G22 Resistance of Plastics to Bacteria

## **7.2. JUSTIFICATION**

These codes and standards are relevant to our project because they apply to a common bathroom wall mounted baby changing station. Although our project is not wall mounted, all lot of these standards will apply to our baby changing station. The first cited standard deals with accessibility for handicap people and space requirements in a building. The second standard deals with safety performance specifications strictly for commercial diaper changing tables. The third says we need to put proper warning label signs on our product. The fourth lays out safety requirements for domestic diaper changing units, and the last gives requirements for plastics to resist bacteria which is important for this application because there are infants involved.

## **7.3. DESIGN CONSTRAINTS**

\* Include at least one example of the following.

### **1.1.1. Functional**

Must be user friendly.

### **1.1.2. Safety**

Must have sidewalls to prevent baby from rolling out.

Must be strong enough to hold an eighteen month old baby.

### **1.1.3. Quality**

Use aluminum folding legs only. No cheaper substitute may be used.

### **1.1.4. Manufacturing**

Diaper bag is to be made of material that is easy to clean.

**1.1.5. Timing**

Manufacturing plant will keep up with the demand and meet all order deadlines.

**1.1.6. Economic**

The diaper bag / changing table combo shall be priced at \$99.

**1.1.7. Ergonomic**

The legs will reach a comfortable changing height.

**1.1.8. Ecological**

Manufacturing plant will not release pollutants into the air or waters.

**1.1.9. Aesthetic**

The diaper bag / changing table combo will be appealing to the eye.

**1.1.10. Life cycle**

The diaper bag / changing table combo should last at least five years before considered unserviceable.

**1.1.11. Legal**

We shall maintain insurance to protect against lawsuits.

**7.4. SIGNIFICANCE**

The legs and base of our product will have to support a baby's weight. We would like to have a factor of safety of around 2. We would like the final product to be tall enough so the adult changing the baby wont have to bend over. The ideal height would be about 36 inches tall and collapse to the size of the diaper bag so it is portable. The legs should be made out of aluminum,

the base of the bag should be plastic and the bag itself should be a wicking type of fabric. The inside of the diaper bag should be made out of an easy cleaning material that is bacteria resistant and machine washable. We also need an one handed operation meaning if a parent has his or her's baby in one arm, they should be able to open the entire system with one hand. The system should also close and collapse with a one handed operation.

## 8. WORKING PROTOTYPE

### 8.1. AT LEAST TWO DIGITAL PHOTOGRAPHS SHOWING THE PROTOTYPE





**8.2. A SHORT VIDEO CLIP THAT SHOWS THE FINAL PROTOTYPE  
PERFORMING**



IMG\_0486.MOV



### 8.3. AT LEAST FOUR ADDITIONAL DIGITAL PHOTOGRAPHS AND THEIR EXPLANATIONS



This image shows the diaper bag. The diaper bag itself can be opened into a changing station without legs. This item was purchased with this capability. The only alteration that was made to the diaper bag were four small cuts for fixing it to the plastic board and legs. The diaper bag was fastened down to the plastic and legs with two thin tie down straps.



This is a picture of the 1/4" plastic sheet that was used as a mounting surface for the diaper bag and legs. Six plastic zip ties were used to hold the plastic to the legs. Twelve holes were drilled in the plastic and the zip ties were directed through the holes and around the aluminum tubes of the legs and tightened. Two tie down straps were used to hold the diaper bag in place by wrapping the straps around the legs, plastic, and base of the diaper bag.



This is a picture of the legs that were used. In this photo the bag sits on top of the legs, but is not fastened down yet. The legs of our design are simply a purchased clothes drying rack made of aluminum. The aluminum legs extend and collapse easily.





This image shows the three components of the design all put together. The plastic is barely noticeably in between the diaper bag and legs. You cannot see the fasteners unless you flip it over and look at the underside of the plastic.

## 9. DESIGN DOCUMENTATION

### 9.1. FINAL DRAWINGS AND DOCUMENTATION

**9.1.1. A set of engineering drawings that includes all CAD model files and all drawings derived from CAD models. Include units on all CAD drawings. See Appendix C for the CAD models.**

**Note: A brief description is offered on the bottom of each figure which emphasizes the function and origin.**

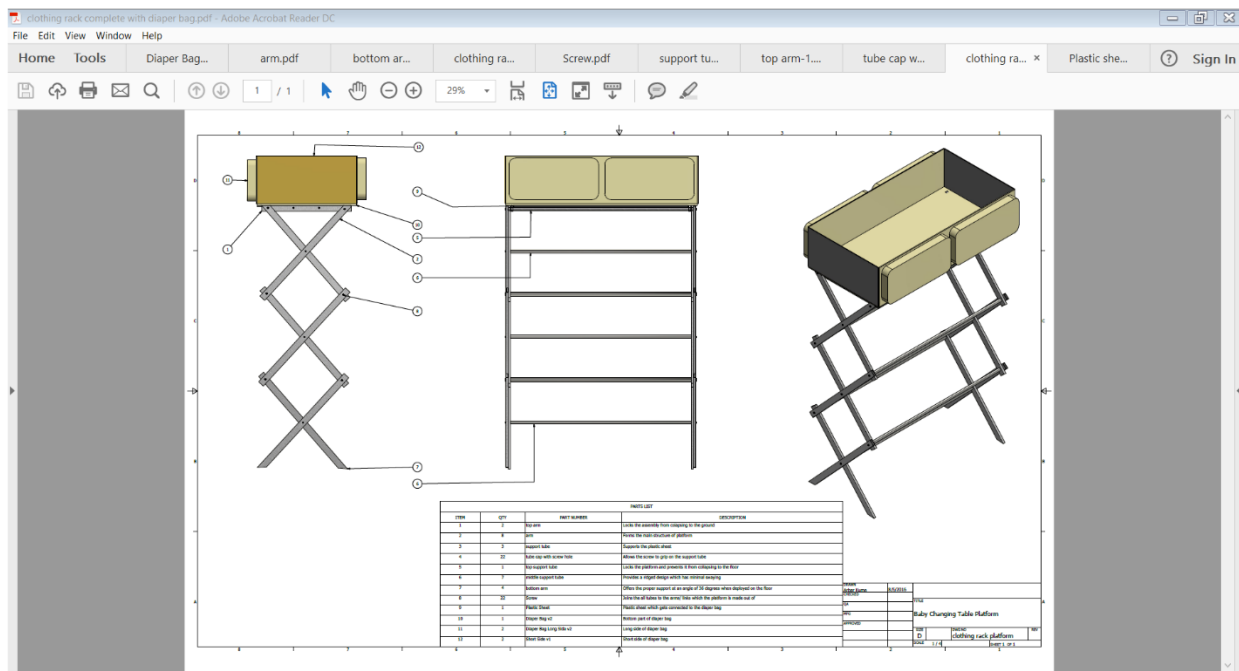

Complete baby changing platform with parts all list. The parts list is made out of all components which make up the design and necessary the purchased items.



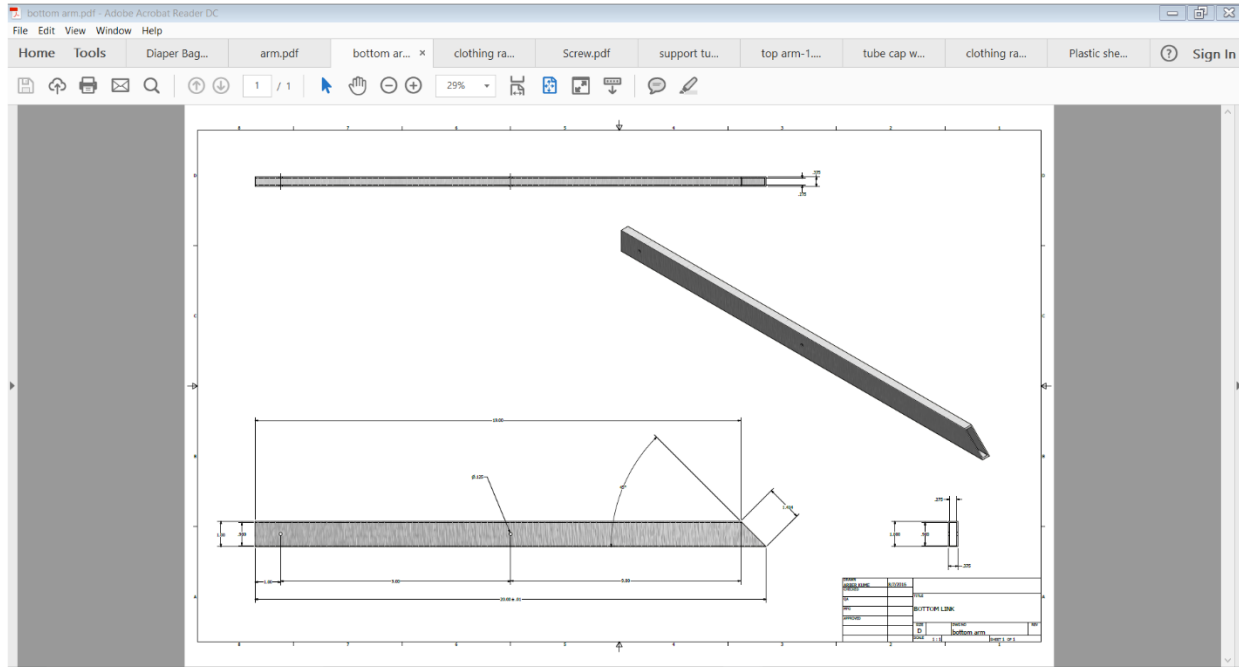

Bottom arm/link which provide an angle of 36° with the floor.

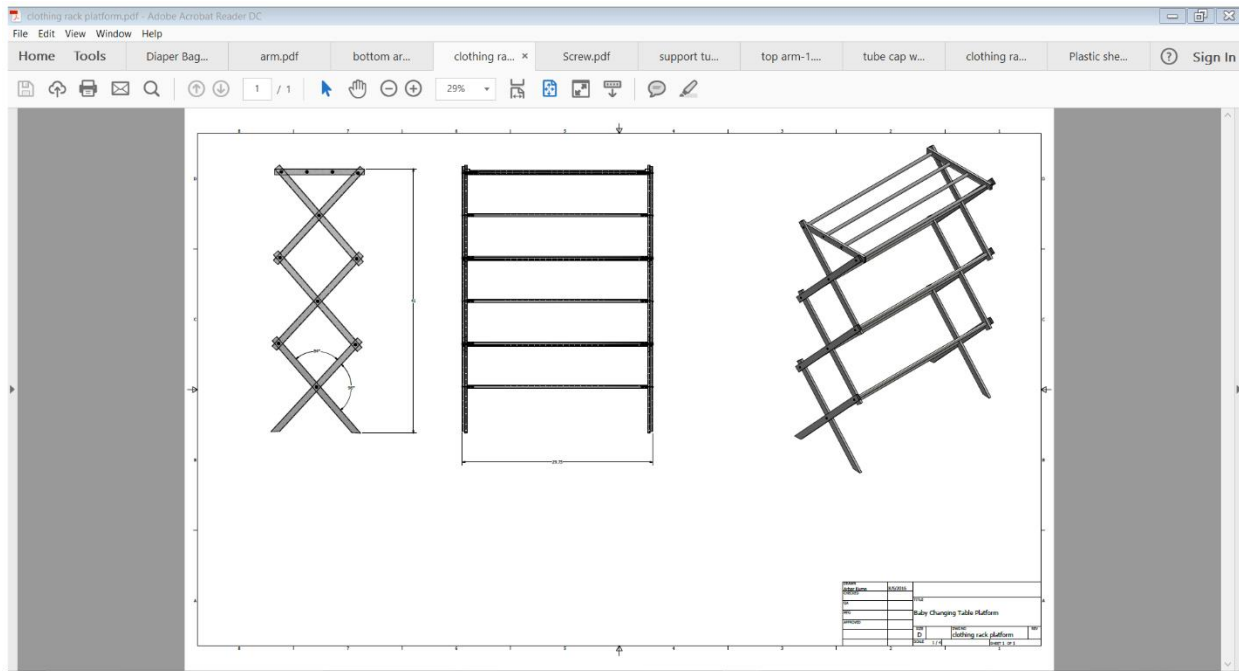

Purchased part which provides a sturdy mechanism for easy deployment.

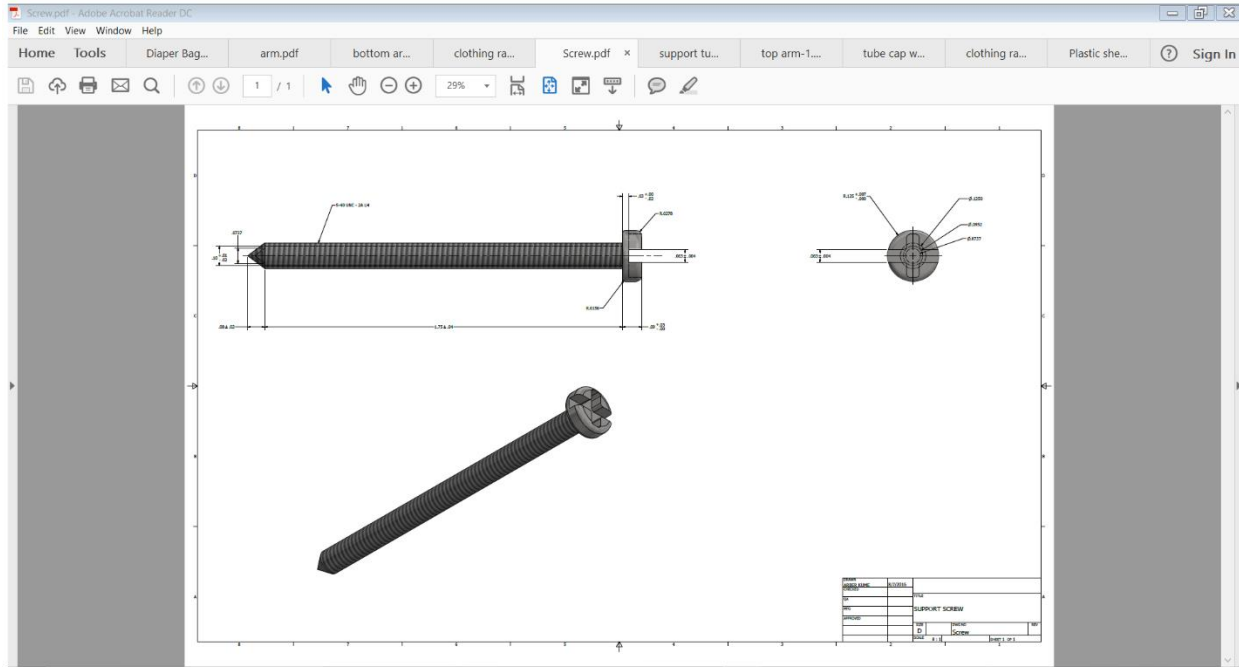

Screws are fastened between the arms and the support tubes to hold the structure together.

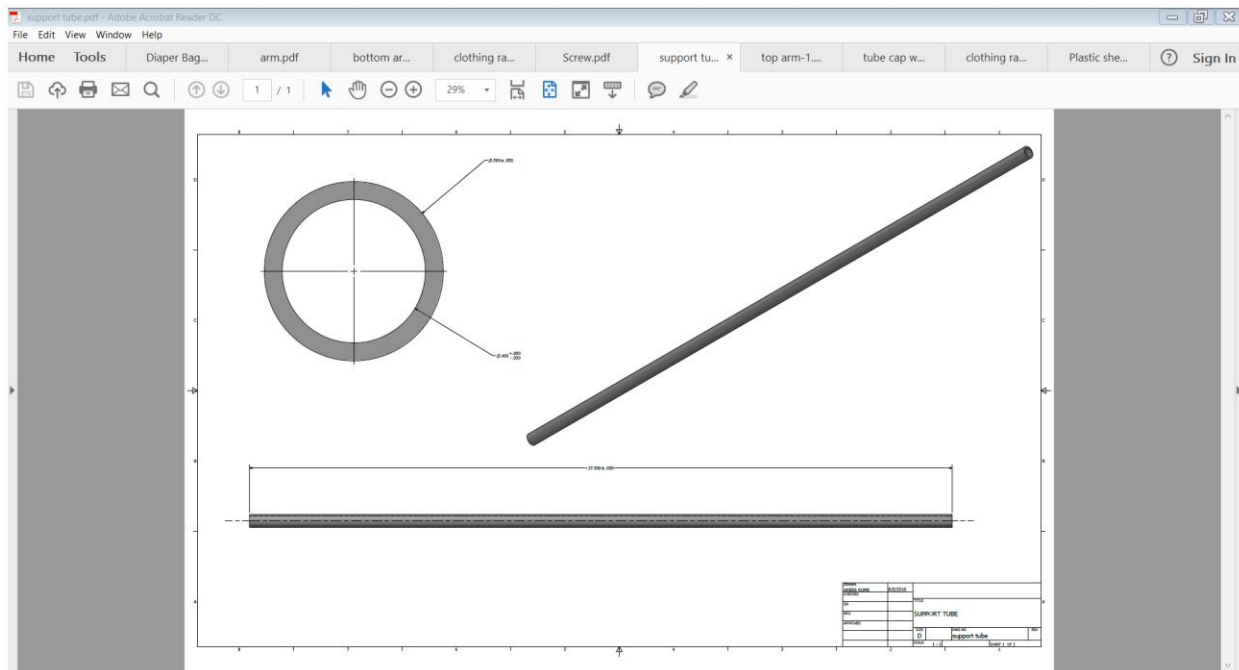

Mild steel, hollow tubes served as further support for the structure preventing it swaying to the point of collapse.





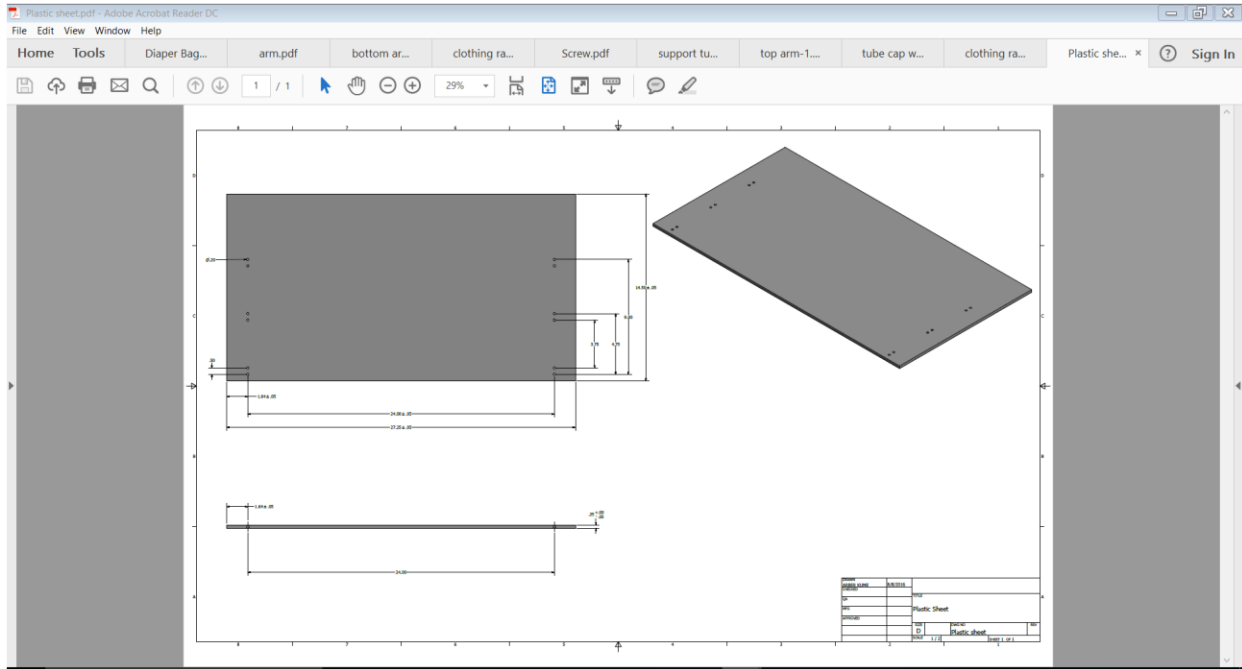

Plastic sheet which offers a flat & durable platform for the diaper bag to attach to.

### 9.1.2. Sourcing instructions

Diaper Bag: For carrying materials for changing diapers

Purchased item from <https://www.amazon.com/Boxum-Bassinet-Multi-purpose-Carrycot-Portacrib/dp/B00ZHMQNPC>

Purchased price of \$64.99

Legs: For raising the diaper bag up to a comfortable changing level.

Purchased item from <http://www.bedbathandbeyond.com/store/product/leifheit-folding-x-frame-clothes-dryer/1045336256?categoryId=12221>

Purchased price of \$49.99

Plastic mounting board: For mounting legs and the diaper bag all together

Purchased item from [http://www.eplastics.com/Marine\\_Board-SEABOARD](http://www.eplastics.com/Marine_Board-SEABOARD)

Purchased price of \$36.14

## 9.2. FINAL PRESENTATION

### 9.2.1. Link to the video presentation

<https://youtu.be/y4ZNW1M5LO0>

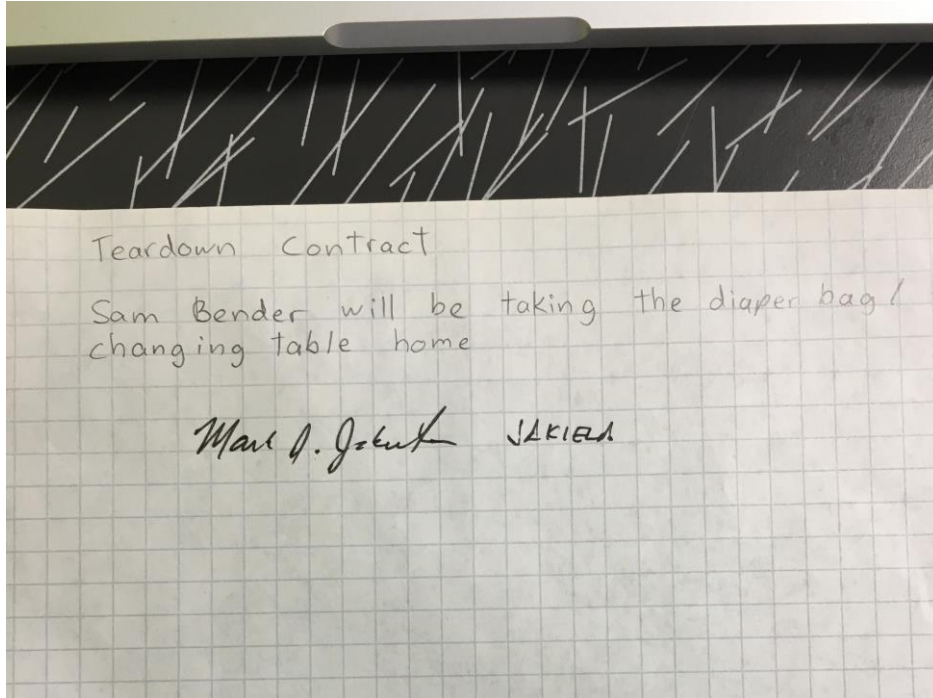

## 10. TEARDOWN

## 11. APPENDIX A - PARTS LIST

- 2' by 3' piece of hard plastic 1/4" thick \$36.14
- Diaper Bag \$64.99

- Collapsible and actuating leg system \$49.99
- Fasteners to fasten legs to plastic
- 1" wide straps to fasten diaper bag to plastic

## 12. APPENDIX B - BILL OF MATERIALS

- 2' by 3' piece of hard plastic 1/4" thick \$36.14
- Diaper Bag \$64.99
- Collapsible and actuating leg system \$49.99
- Fasteners to fasten legs to plastic
- 1" wide straps to fasten diaper bag to plastic

## 13. ANNOTATED BIBLIOGRAPHY

- Moulton, Teresa. "Patent US20060174415 - Portable Diaper Changing Cot." **Google Books**. N.p., 23 Mar. 2003. Web. 05 Aug. 2016.
- Hall, Carmelina. "Patent US7681267 - Collapsible and Portable Baby Changing Table." **Google Books**. N.p., 27 Mar. 2010. Web. 05 Aug. 2016.