

Washington University in St. Louis  
**Washington University Open Scholarship**

---

All Theses and Dissertations (ETDs)

---

January 2009

Open Collaborative Mechanical / Product Design  
- User as Developer A New Design Methodology  
for Internet Era Business Innovations and  
Entrepreneurship

Jing Zheng

*Washington University in St. Louis*

Follow this and additional works at: <https://openscholarship.wustl.edu/etd>

---

**Recommended Citation**

Zheng, Jing, "Open Collaborative Mechanical / Product Design - User as Developer A New Design Methodology for Internet Era Business Innovations and Entrepreneurship" (2009). *All Theses and Dissertations (ETDs)*. 401.  
<https://openscholarship.wustl.edu/etd/401>

This Dissertation is brought to you for free and open access by Washington University Open Scholarship. It has been accepted for inclusion in All Theses and Dissertations (ETDs) by an authorized administrator of Washington University Open Scholarship. For more information, please contact [digital@wumail.wustl.edu](mailto:digital@wumail.wustl.edu).

WASHINGTON UNIVERSITY IN ST. LOUIS

School of Engineering and Applied Science

Department of Mechanical, Aerospace, and Structural Engineering

Thesis Examination Committee:

Mark Jakiela, Chair

Michael Swartwout

Guy Genin

Keith Sawyer

Christopher Gill

Open Collaborative Mechanical / Product Design - User as Developer  
A New Design Methodology for Internet Era Business Innovations and Entrepreneurship

By

Jing Zheng

A dissertation presented to the School of Engineering  
of Washington University in partial fulfillment of the  
requirements for the degree of

DOCTOR OF SCIENCE

August 2009

Saint Louis, Missouri

## ABSTRACT OF THE DISSERTATION

Open Collaborative Mechanical / Product Design - User as Developer

A New Design Methodology for Internet Era Business Innovations and Entrepreneurship

by

Jing Zheng

Doctor of Science in Mechanical, Aerospace, and Structural Engineering

Washington University in St. Louis, 2009

Research Advisor: Professor Mark Jakiela

In product design and development projects, the most important part is identifying user needs. Traditional methods such as surveys, focus group studies and interviews are expensive and sometime inaccurate in identifying those needs. Inspired by the open source software development, along with the research that has been done on the “lead user” method, the method of using collective customer wisdom to modify old products or even develop new products has become an emerging new design method and is starting to get popularity and success. However, the effectiveness of such method comparing to the traditional face to face “close” development method is a question that keeping established businesses from apply such method. At the same time, failures of early attempts to use such methods also cast doubts about the quality of this method. We set up two experiments to compare this method and the traditional face to face method, and found out that the effectiveness of both methods were about the same. Problems of implementing such

method also emerged from the experiment, possible solutions are discussed, and future studies are also identified.

Comparing this method to the open source software design, there is one stage of the development that is unique for mechanical products. The prototyping and manufacturing of mechanical products involved cost and quality control issues that don't exist in software development. We conducted an experiment of applying a collaborative open design approach to test the possibility and necessity of applying such design method during prototype fabrication. Our results showed that open collaborative design is necessary to identify true customer needs. A product prototyping and manufacturing method is also proposed for real world practice.

The open collaborative design method is new and is not easily adopted by established businesses, as they are often reluctant to implement new approaches. Entrepreneurs can usually take advantage of this situation and establish their share of the market, even possibly driving out the established businesses later on. We argue that the open collaborative design method is one such technology. Future research and practice is proposed and discussed.

# Acknowledgments

The author thanks the Ewing Marion Kauffman Foundation of Kansas City and the Skandalaris Family for providing funds for this research. This support was administered by the Center for Research on Innovation and Entrepreneurship at the Washington University School of Law.

Additionally, I would like to express my sincere appreciation to the mentorship and individual help that I collected during the entire course of this research:

Faculty advisor and dissertation supervisor, Hunter professor of Mechanical Engineering: Mark Jakiela.

Dissertation committee: Keith Sawyer, Chris Gill, Guy Genin, Michael Swartwout.

Faculty and Staff at Mechanical, Aerospace and Structural Engineering department: Ruth Okamoto, Xavier Avula, Tom Bever, Gene Bulfin, Mary Molloy.

Former adjunct faculty: Carl Bagget, Ray Slesinsky.

Colleagues: Brinton Callaghan, Anthony Friedman, Lindsey Jubel, James Cosentino, students in MASE101 2008 class and MASE 404P 2008 and 2009 classes.

Friends: Zhe Zhang, Xin Geng, Peizhong Su, and John Wright.

Jing Zheng

*Washington University in St. Louis*

*August 2009*

Dedicated to my wife, Jian Wu, and our first child.

# Contents

Abstract.....	ii
Acknowledgments.....	iv
List of Tables.....	ix
List of Figures.....	x
<b>1 Introduction: Traditional Design Method vs. Open Design Method.....</b>	<b>1</b>
1.1 Traditional Mechanical Design and Product Development Process.....	1
1.1.1 Capturing the Customer Needs.....	2
1.1.2 Predicting the Market Volume.....	3
1.2 The Emerge of Customer Participated Design.....	4
1.2.1 The Terminologies of Open Design.....	5
1.3 Modes of Open Design.....	7
1.3.1 Individual Effort: A Mini Case Study.....	8
1.3.2 Crowdsourcing.....	11
1.3.3 Open Collaborative Design (OCD).....	14
1.4 The advantage of Open Design.....	15
1.4.1 Capturing the customer needs.....	15
1.4.2 Turn marketing research into sales: the customer commitment method.....	15
1.5 Open Design License.....	19
1.6 Problems and challenges emerged from current <i>Open Design</i> practice.....	23
1.6.1 The flat control system.....	23
1.6.2 Managing the crowd.....	24
1.6.3 The effect of “ghost town”.....	25
1.6.4 Obstacles of implementing open design method.....	26
1.7 Research plan for OCD method emphasis on Mechanical Engineering.....	27
1.7.1 The Three Phase of Product Design in an Academic Environment....	29
1.7.2 Experiment Tool: Wedesign Forum.....	32
<b>2 Pilot Experiments of Using Online Collaborative Tools: Wedesign Forum....</b>	<b>35</b>
2.1 Introduction.....	35
2.2 Experiment Method.....	36
2.2.1 Subjects.....	36
2.2.2 Design Method: Control Mode.....	37
2.2.3 Design Method: Parliamentary Mode.....	40
2.3 Experiment Results.....	44
2.3.1 Control Mode.....	45
2.3.2 Parliamentary Mode.....	48
2.4 Survey Results.....	53

2.4.1	Control Mode.....	53
2.4.2	Parliamentary Mode .....	57
2.5	Implications and Discussion .....	61
2.5.1	The Size and the Content of the Design Challenge .....	61
2.5.2	The Size of the Team.....	62
2.5.3	How to Address the User Needs .....	63
2.5.4	Would Design Drawing Quality Affect Community Choice of Design? .....	64
2.5.5	“Player” vs. “Watcher” .....	64
2.5.6	Should Management Be Imposed? .....	65
2.6	Summary.....	66
<b>3</b>	<b>Open Collaborative Conceptual Design for Mechanical Engineering .....</b>	<b>68</b>
3.1	Introduction .....	68
3.2	Related work .....	72
3.2.1	Face-to-face vs. computer mediated collaboration on education and learning.....	72
3.2.2	Distributed or co-located teams effectiveness related to interaction and management .....	73
3.3	Methods.....	74
3.3.1	Subjects .....	74
3.3.2	Experiment setup .....	75
3.3.3	Concept development challenge.....	77
3.4	Experiment Results .....	80
3.5	Survey Results .....	85
3.6	Implications and Discussion .....	87
3.6.1	The rate of participation.....	88
3.6.2	The rate of collaboration.....	88
3.6.3	Group size effect .....	89
3.6.4	“Playing” versus “watching” .....	89
3.6.5	The rate of satisfaction .....	90
3.6.6	Test subjects for TO method .....	90
3.6.7	Individual vs. Team.....	91
3.7	Summary.....	92
<b>4</b>	<b>Open Open Collaborative Embodiment Design for Mechanical Engineering .....</b>	<b>93</b>
4.1	Introduction .....	93
4.2	Related work .....	95
4.3	Methods.....	95
4.3.1	Subjects .....	96
4.3.2	Experiment setup .....	96
4.3.3	Embodiment challenge.....	97
4.4	Results .....	101
4.5	Implications and Discussion .....	103
4.5.1	The size of the task.....	103



4.5.2	The rate of participation.....	104
4.5.3	The rate of satisfaction .....	105
4.5.4	The Application of CAT .....	106
4.6	Summary.....	107
<b>5.</b>	<b>Open Collaborative Prototyping and Manufacturing for Mechanical Engineering</b> .....	<b>108</b>
5.1	Introduction .....	108
5.2	Related work .....	113
5.2.1	Virtual prototyping.....	113
5.2.2	Rapid Prototyping.....	114
5.2.3	Toolkit for user innovation (TUI).....	116
5.3	Methods.....	117
5.3.1	Subjects .....	118
5.3.2	Experiment setup .....	118
5.3.3	Experiment challenge.....	121
5.4	Results .....	123
5.4.1	Concept Category.....	123
5.4.2	Dry run & Contest Scores.....	123
5.5	Implications and Discussion .....	125
5.6	Summary.....	131
<b>6</b>	<b>Conclusion</b> .....	<b>133</b>
6.1	Building and maintaining the community.....	133
6.1.1	Real people .....	134
6.1.2	Project community size.....	135
6.1.3	Investors and Manufacturers .....	135
6.1.4	Making money or having Fun?.....	136
6.1.5	Using established community .....	136
6.2	Choosing community projects .....	137
6.3	Effectiveness of the online product development tools .....	137
6.4	Lesson learned from experiments .....	138
6.4.1	Finding leaders or imposing project management.....	138
6.4.2	Project group size .....	139
6.4.3	Real world experiment.....	139
<b>Appendix A</b>	<b>Idea Generation: Exit survey</b> .....	<b>141</b>
<b>Appendix B</b>	<b>Embodiment: Exit survey</b> .....	<b>143</b>
<b>Appendix C</b>	<b>Prototyping Survey</b> .....	<b>145</b>
<b>References</b>	.....	<b>148</b>
<b>Vita</b>	.....	<b>154</b>

# List of Tables

Table 2.1: Parliamentary motions.....	51
Table 2.1: Concept Generated for the Sub-Problems.....	51
Table 3.1: Inter-judge Reliability vs. Number of Judges.....	83
Table 3.2: Real Team vs. Nominal Team Results .....	84
Table 3.3: FTF vs. TO results.....	85
Table 4.1: Inter-judge Reliability .....	102
Table 4.2: Mean and Variance .....	102
Table 4.3: Results of ANOVA .....	103
Table 5.1: Kit Materials (Supplied in Class and Available Externally).....	122
Table 5.2: Design Changed .....	124
Table 5.3: Migration Trend .....	124
Table 5.4: Competition Score .....	124

# List of Figures

Figure 1.1: Concept Generation Sketch .....	29
Figure 1.2: Embodiment Calculation Example.....	31
Figure 1.3: Prototype Machine .....	32
Figure 1.4: Wedesign Forum.....	33
Figure 1.5: Inside a Design Project .....	34
Figure 2.1: Design Concept: Collapsible Shield .....	45
Figure 2.2: Design Concept: Armadillo Backpack.....	46
Figure 2.3: Design Concept: Electric Gloves .....	46
Figure 2.4: “Winner” Design: Dog Repel v1.0.....	47
Figure 2.5: Design Concept: Tent .....	49
Figure 2.6: Design Concept: All-in-one “freshening up” tool set.....	50
Figure 2.7: Concept Winner: “Tent” .....	52
Figure 3.1: Top View of the Conveyor.....	78
Figure 3.2: Side View of the Conveyor .....	79
Figure 4.1: Dual “Fork” and Conveyor System .....	98
Figure 5.1: Challenge Side view .....	121
Figure 5.2: Challenge Top view .....	121
Figure 5.3: Design Categories .....	123
Figure 5.4: Failure of the Lazy Tongue Design.....	127
Figure 5.5: Open Manufacturing Sample .....	130

# Chapter 1

## Introduction: Traditional Design Method vs. Open Design Method

### 1.1 Traditional Mechanical Design and Product Development Process

Ulrich & Eppinger (2003) divide a Generic Product Development Process into six phases: Planning, Concept development, System-level design, Detail design, Testing and refinement, and Production ramp-up. If conducting product development within a company, these six phases usually involve close collaboration between Marketing, Design and Manufacturing department, as well as Research, Finance and General Management departments. Among these six phases, the Planning phase is usually considered as the most important phase of all product development process, because it is in this phase that the company needs to correctly capture the true customer need and translate those needs into correct product specifications. Additionally, it is in this phase that the Marketing department needs to correctly predict the market volume of the proposed new product in order for the Manufacturing department to prepare correct tools and production methods to ensure product quality while lowering manufacturing cost. However, it is in this planning phase that the traditional mechanical design and product development process is facing serious challenges.

Studies show that large failure rates exist in new product commercialization. The failure rate is reported as ranging from one-third (Poolton and Barclay, 1998) to fifty percent or more (Ogawa and Piller, 2006). The primary reason for these failures, as Ogawa and Piller (2006) summarized, has been found to be inaccurate understanding of user needs. Many new product development projects are unsuccessful because of poor commercial prospects rather than due to technical problems. Research found that timely and reliable information on customer preferences and requirements is the most critical information for successful product development (Bacon, *et al.* 1994). Here, I want to elaborate on the two aspects of the Planning phase in which traditional methods are falling short: capturing the customer needs and predicting the market volume.

### **1.1.1 Capturing the Customer Needs**

The first and the uttermost important task of product development is to identify the customer needs, and the traditional way of doing so is by conducting customer interviews, focus group studies, and even observing the product in use in real time (Ulrich and Eppinger, 2003). However, choosing customers to conduct those interviews and studies is not an easy matter. Griffin and Hauser (1993) provided examples of how many customer interviews are needed in order to reveal most of the customer needs. In an experiment, they interviewed 30 potential customers of portable food-carrying and storing devices (coolers, picnic baskets, knapsacks, bike bags, etc.), and estimated that doing so captured 89.8% of all the needs. With improved interviewing techniques, in

another study of customer needs for office equipment they found that nine customers and eight focus groups identified 98% of the needs. They further suggested that 20-30 interviews are necessary to get 90-95% of the customer needs. They also pointed out that even for a low estimate of the cost for a professional interviewer, the total costs per interview are in the range of \$1000-2000 for a single market segment. For a product that in a complex category, or a manufacturer who has multiple product line, the cost would multiply 5-10 time respectively.

As Thomke and von Hippel (2002) pointed out, “The difficulty (of traditional market research) is that fully understanding customers' needs is often a costly and inexact process. Even when customers know precisely what they want, they often cannot transfer that information to manufacturers clearly or completely.” This is because the need information tends to be “*sticky*.” Stickiness is defined as “the incremental expenditure required for transferring a certain unit of information to a specified locus in a form that is usable to the information seeker” (von Hippel, 1994). Besides, the manufacturer’s solution to a certain problem tends to be *solution* oriented, while the customer’s solution tends to be *need* oriented (Toubia and Flores. 2006). This makes the search for user needs inexact.

### **1.1.2 Predicting the Market Volume**

Finding the right products that customers need is one thing, finding how many of those products that the customers want is quite another. In the modern “mass production”

manufacturing method, the cost per unit is lowered by producing more units. However, if those produced units fail to be sold to the customers, such cost-saving strategy cannot be realized.

Take the automobile industry in United States for example. The manufacturer produces a certain model according to marketing research suggestions and then relies on its dealerships to sell those products to the customer by using sales incentives and advertising. Each model gets several face lift design changes within a few years before the model gets completely redesigned. Each year, the dealer would introduce large discounts in price of certain models to make room for the new models to in dealership lots. Those discounts usually cut deep into the manufacturer's profit margin and these sometimes amount to thousands of dollars a car (Argawal, Kumaresh, and Mercer, 2002). This is a very costly business model for the Original Equipment Manufacturer (OEM).

## **1.2 The Emerge of Customer Participated Design**

Much research has been conducted to address these two challenges. One approach, a new method involving customers into the design process has begun to get attention and gather momentum. I would like to call this approach an *Open Product Design* method. The idea behind this approach is simple, instead of guessing what the customers want, why not let the customers tell and help to get exactly what they want?

A few years ago, the term *Open Product Design* was largely unheard of anywhere except in the *open source* software development industry. By now, however, some of the first generation research open-design and business practice for tangible artifacts has already run a full lifecycle (“Thinkcycle”, Coffin 2006; “Cambrian House”, Schonfeld 2008). Although still in its nascence, the open design method had been adopted by many startup companies in some ways and gained the attention of many researchers. Due to its relatively new status and diverse sub-approaches that each interested group took, many new terms emerged to address similar but different aspect of the “open design” approach, which itself is a term that needs some specifications. So, I would like to present this new product development method starting with the descriptions of the open design method.

### **1.2.1 The Terminologies of Open Design**

Although it hasn’t turned into a “fight” like what happened between *Free Software* and *Open Source* in the software industry (Stallman 2007), there are many terminologies co-existing in the current “Open Design” domain, with each having its own emphasis. These terms share some similar characteristics. Understanding the true meaning of these terms and the domain they cover are very important to for us to accurately conduct the research.



**Open Design:** The word “open design” is a generic term that researchers usually use to describe the openness of the process, not the openness of the designed artifact itself (Tellioglu, Wagner and Lainer, 1998). However, it is also considered by many as the development of physical products, machines and systems through use of publicly shared design information. In some way, *open design* has goals and philosophy which are identical to the *open source* approach in the software industry, except that *open design* is more of open *machine* design.

**Open Source Design:** The term *open source design* is directly borrowed from open source software. Inherently, this means the design detail is not a proprietary property of the manufacturer of the product. However, this is somewhat confusing with another practical term *open source hardware* design, which basically is computer peripheral hardware design that uses open source software. The word *source* is largely related to the software source code, while in mechanical engineering the correspondent term would be technical drawing, with dimensions and tolerance specifications; in electronic engineering would be PCB board design drawing with component and chipset specification, etc.

**Crowdsourcing:** The word “Crowdsourcing” was first coined in the context of an article in Wired Magazine article (Howe 2006). It is a neologism for the act of taking a job traditionally performed by an employee or contractor, and outsourcing it to an undefined, generally large group of people, in the form of an open call, with or without a monetary reward. Usually, Crowdsourcing activities with a monetary reward do not

involve collaboration and in most cases, the job result is not open to the public. In this sense, the Crowdsourcing domain has something that is not covered by the open design domain.

**Open Collaborative Design:** This is the term we would use in this thesis to describe open design that demands collaboration. Intuitively, this means the design is conducted with collaboration between participants and the result of the design is open to the public.

We can see from these definitions that Open Collaborative Design is a sub-category of the Open Design. The opposite category would obviously be Open non-collaborative Design. To further elaborate upon the open collaborative design, it is important to understand the different modes of open design and how they affect the way we usually conduct our product design and development process.

## 1.3 Modes of Open Design

The open collaborative design method is new; the open design method, however, is not. Some open design activity can be dated back to the eighteen century<sup>1</sup>. Here I want to discuss the modes of open design and their correspondent applications.

---

<sup>1</sup> The “longitude prize”, offered by the British Parliament in 1714 to solicit ideas for obtaining longitude at sea, is considered by me as one of the early Crowdsourcing efforts, which we will discuss later in this dissertation.

### 1.3.1 Individual Effort: A Mini Case Study

It is a fact that there are many individual users in the world that just can't be satisfied by what manufacturer offers them. Instead of waiting for changes to happen, they take matters into their own hands and go on modifying, hacking, or even building a totally new product. Such user is what von Hippel (1986) defined as "lead users". He defines them as

users whose present strong needs will become general in a marketplace months or years in the future. Since lead users are familiar with conditions which lie in the future for most others, they can serve as a need-forecasting laboratory for marketing research. Moreover, since lead users often attempt to fill the need they experience, they can provide new product concept and design data as well." (von Hippel, 1986).

Among those "lead users", some of them are so active and open minded that they would present their design to the public for free. The reasons behind this vary. Some are for the purpose of promoting a certain sport or hobby; others do this just for fun.

I did a mini case study on one of such "lead user", Mr. Jostin Halford. Mr. Halford is working for his family business and has access to CNC (Computer Numerical Control, a precision manufacturing machine) machines. He has a hobby of sports shooting and is interested in firearms. There is one popular sports rifle called the AR15, which is a civilian model of the famous military variant – the M16. Many firearm owners have one or more, while those who do not most likely would love to have one. There are many manufacturers of this rifle, or the parts of it. The center piece of this rifle, the lower receiver, is the regulated part that needs a federal background check and approval either to purchase it or manufacture it. Other parts of the rifle are not regulated for purchasing

or manufacturing since the rifle won't work without the lower receiver. So in order to produce and sell this lower receiver, both the manufacturer and the customer need to get a license for producing and processing this part. Some manufacturers who do not have that license are still allowed to manufacture an incomplete part, usually having all the external features manufactured but no holes are drilled to make room for the firing mechanism, which is the essential functionality of the lower receiver. Such product is usually called a "paper weight" among enthusiasts. There are some customers, like Mr. Halford, for example, that have the capabilities to finish such "paper weights" and turn them into real lower receivers. Doing so requires the same license that would be required to *own* a finished lower receiver. Since the customer has to obtain federal approval for possessing or manufacturing this part anyway, some enthusiastic customers find satisfaction in turning "paperweights" into lower receivers by themselves.

Mr. Halford noticed this and also realized that many of these enthusiasts could not transform a paperweight into a lower receiver because drilling the needed holes requires at least a milling machine, which is not a common household tool that regular people would possess in their workshop. Being a skilled mechanical engineer, Mr. Halford figured out a way of using a regular drill press to do the milling work by using a special jig that he designed specifically for this purpose. Initially, he thought about applying for a patent to protect his invention, but later decided not to do so because of the cost of applying for patent and possible future lawsuits. Instead, he decided to sell the jig while making the design freely available at the same time. Customers can access such information from his website [www.cncguns.com](http://www.cncguns.com). Although he didn't publish his

technical drawings of the jig, other people who have basic mechanical engineering knowledge could easily re-engineer the design through his thorough tutorial instruction of using this jig<sup>2</sup>. I asked him whether he would be concerned if someone takes his design and sells a similar product at a lower price. His answer is worth noting in many ways. First, he expressed that it does concern him if this happens. However, the market for this product is relatively small and the demand for this product is low. If he sold thousands of dollars worth of product, he probably would have applied for a patent for it. For now, patenting is not worthwhile. Second, if such copying does happen, he would try to sell the best product at the best price (to compete). Third and most important, he wants to share his hobby with other enthusiasts, thereby helping to promote this sport. On his website, he stated: “I hope my website will help you get started in this hobby, if it's not your hobby already. I share all my information for free, and I hope you will do the same to help keep the gun community strong.” For the record, Mr. Halford is breaking even with this jig business. It attracted many customers and some of them become his friends. No customer had ever returned this product; but many expressed satisfaction with his work. Some even asked him for other products that are not listed on his website.

Mr. Halford is not alone. There are many such capable and open minded user-turned-to-developers available in almost every segment of the business world. For example, there is an electronic hacking community<sup>3</sup> in which people hack and add functions to

---

<sup>2</sup> The tutorial can be found at <http://www.cncguns.com/projects/ar15lower80tutorial.html>.

<sup>3</sup> [www.hackgadget.com](http://www.hackgadget.com)

existing electronic products, or design and produce new products by using existing parts and assemblies. The results and procedures are shared for free.

As we can see from these examples, those individual efforts are initiated, developed, and then released to the public all by the individual people. However, those individuals also have the capability and willingness to collaborate, when those with similar interests meet. It is those individual efforts of opening up their own work and a sharing spirit that makes broader open design activities possible. One of the most talked about is so called “Crowdsourcing”.

### **1.3.2 Crowdsourcing**

The word “Crowdsourcing” was first coined in an article in Wired Magazine by Howe (2006).

Technological advances in everything from product design software to digital video cameras are breaking down the cost barriers that once separated amateurs from professionals. Hobbyists, part-timers, and dabblers suddenly have a market for their efforts, as smart companies in industries as disparate as pharmaceuticals and television discover ways to tap the latent talent of the crowd. The labor isn’t always free, but it costs a lot less than paying traditional employees. It’s not outsourcing; it’s crowdsourcing.

There are two kinds of Crowdsourcing approach; collaborative and non-collaborative<sup>4</sup>.

The non-collaborative Crowdsourcing has several forms; each with characteristics that make it suitable for certain tasks and businesses. I divide them into three categories:

---

<sup>4</sup> From design point of view, the non-collaborative Crowdsourcing is another kind of individual effort, since the individual participants do the design work all by themselves. However, such design is conducted to respond a challenge that not initiated by the individual, hence make it different from the individual effort we discussed before. From a manufacturer point of view, they are drawing design solution from the

**Bicycle Wheel.** A bicycle wheel consist three major parts: the hub, the spoke, and the rim. If we consider the hub to be the manufacturer, the rim to be the customer, then the spoke is the communication between the two. In this form, the manufacturer interacts with the customer in an one-on-one basis. Examples of this form of Crowdsourcing are usually *prizes for solution* or *design competition*. One of the most commercially successful Crowdsourcing companies in this form is Innocentive<sup>5</sup>.

InnoCentive is a global, online marketplace where organizations in need of innovation—companies, academic institutions, public sector, and non-profit organizations—can utilize a global network of over 160,000 of the world’s brightest problem solvers<sup>6</sup>.

In this form of Crowdsourcing, the design challenge is open to the public; the design phase is usually conducted by the participants privately. The result is also confidential. In the case of Innocentive, there is even a formal intellectual property handover from the solver to the seeker before the solver can claim the prize money.

**Salami Techniques.** The term “Salami Techniques” is usually used to describe a fraud that involves the theft of small amounts of assets from a large number of sources without noticeably reducing the whole. The idea is that taking one or two slices of salami from the big chunk wouldn’t get noticed. In a banking system, for

---

crowd, not from a single individual. So Crowdsourcing is a more of a management term, not a design method term.

<sup>5</sup> [www.innocentive.com](http://www.innocentive.com)

<sup>6</sup> Retrieved from [www.innocentive.com](http://www.innocentive.com) FAQ section “What is Innocentive?”

example, the amount of interest to be credited to an account is rounded off. Instead of rounding off the number, a fraction of it is credited to a special account owned by the perpetrator. In the case of Crowdsourcing, this refer to some task that one party can divide up and ask the crowd to do a small chunk of it with a little cost. Collectively, a huge task can be accomplished this way with comparable less cost (Howe, 2006)

One example of the practice is the Amazon Mechanical Turk. In 2005, Amazon.com launched the Amazon Mechanical Turk, a platform on which crowdsourcing tasks called "HITs" (Human Intelligence Tasks") can be created and publicized and people can execute the tasks and be paid for doing so. For software developers, the Amazon Mechanical Turk web service solves the problem of building applications that until now have not worked well because they lack human intelligence. Humans are much more effective than computers at solving some types of problems, like finding specific objects in pictures, evaluating beauty, or translating text. The Amazon Mechanical Turk web service gives developers a programmable interface to a network of humans to solve these kinds of problems and incorporate this human intelligence into their applications.

**User Toolkit.** Toolkits for user innovation is an emerging alternative approach in which manufacturers actually *abandon* the attempt to understand user needs in detail in favor of transferring *need-related* aspects of product and service development to users (von Hippel and Katz 2002). This form of Crowdsourcing is developed by the trend shift of manufacturing from “mass production” to “mass customization” (Pine, 1993)



Dell is one good example of applying this form of Crowdsourcing. This computer manufacturer built their entire manufacturing process on the customer's demand. Its website has the capability of letting customers to choose components that they prefer within thousands of options available. The manufacturing will not start until customers configured their machine and placed order either online or through telephone call. Later, Dell even opened an affiliate website, [www.ideastorm.com](http://www.ideastorm.com), to collect customer's suggestion of new product ideas that is not available on the existing website.

Similar practice can also be found in the Auto industry. At the current time, almost all major automobile manufacturers have their configuration tools on their company website that allow customers to virtually make the car that they want to buy and place an order before the company commits to manufacture the exact vehicle.

### **1.3.3 Open Collaborative Design (OCD)**

The open collaborative design is actually part of the Crowdsourcing method we discussed above. However, it is a form that hasn't been studied much. Some pioneers who practiced this method have already failed, due to wrong business models and / or ineffective execution (Schonfeld, 2008). Understanding the nature of this method and the correct way of implementing it are the major interest of this research.

Intuitively, *Open Collaborative Design* means doing open design work collaboratively. Participants are working together to get something done. Thus psychological and sociological aspects affect the design outcome. There are many researchers in other

discipline that have explored in detail group productivity and related issues. It is our research interest to study how open collaboration would affect a product design process in a Mechanical Engineering domain.

## **1.4 The Advantage of Open Design**

### **1.4.1 Capturing the Customer Needs**

Because of cost constraints, the traditional method of capturing customer needs is done by sampling the customer base and hoping it would capture the true user needs. Intuitively, under the assumption that it could reach a broader customer base than typical market survey and focus group study, the Open Design approach would capture the customer needs more accurately. In this approach, the customer would come to the manufacturer demanding what they need, instead of waiting for the manufacturer to predict what they need. However, new methods demand new study and understanding of how and why this is going to work.

### **1.4.2 Turn Marketing Research into Sales: the Customer Commitment Method**

As discussed before, the traditional development process is very inefficient to predict market volume. Predicting what customers want is one thing, successfully selling to them is quite another.

As companies become more customer driven, they have resorted to inventing new programs and procedures to meet every customer request. But as

customers and their needs grow increasingly diverse, such an approach has become a surefire way to add unnecessary cost and complexity to operation” (Gilmore and Pine, 1997).

Research on consumer behavior has long recognized that the trend of customer needs turns from a homogeneous market into “an explosion of subjectivity” (Addis and Holbrook, 2001). This shift eventually forced manufacturers to change from *Mass Production* to *Mass Customization* (Pine, 1993). Companies throughout the world have embraced mass customization in an attempt to avoid those pitfalls and provide unique value to their customers in an efficient manner (Gilmore and Pine, 1997). Dell computer would let the customer pick the components and place an order by phone or online shopping tools before they commit to the manufacturing of the computer; Car companies like Ford, GM and Chrysler would build the car exactly like what the customer wanted through hundreds or even thousands of choice combinations; New home construction companies would let the customer to choose and change, from floor plan to the color and size of the ceramic tile in the bathroom before they start building the home (Cox and Alm, 1998). This “build to order” approach greatly reduces the manufacturer’s inventory and increases the product and cash flow. However, exploring the scope of those options is still a marketing research effort.

There is another practice that pushes this method even further to satisfy customer needs, help manufacturers lower costs on marketing research, and even eliminate the possibility of product failure. Ogawa and Piller (2006) provided an example of such business model, and I quote as following:

Started in 2000 by designers Jake Nickell and Jacob DeHart, *Threadless*<sup>7</sup> focuses on a hot fashion item, t-shirts with colorful graphics. This is a typical hit-or-miss product. Its success is defined by fast changing trends, peer recognition, and finding the right distribution outlets for specific designs. Despite these challenges, none of the company's many product variants ever flopped. But Threadless has neither sophisticated market research or forecasting capabilities nor a complicated flexible manufacturing system. Rather, all products sold by Threadless are inspected and approved by user consensus before any larger investment is made into a new product. Only after a sufficient number of customers have expressed their explicit willingness to buy a new design, the garment is produced. If this commitment is missing, a potential design concept is dismissed. But if enough customers pledge to purchase the product, the design will be finalized and go into production. In this way, market research expenditures are turned into early sales. New designs regularly sell out fast, but are reproduced only if a large enough number of additional customers commit to purchase a reprint. Some customers are even integrated deeper in the new product development process. All new designs are submitted entirely by the community, which includes hobbyists, but also professional graphic designers. The company exploits a large pool of talent and ideas to get new designs (much larger than it could afford if the design process would have been internalized). Creators of submissions which are selected by other users get a \$1000 reward, and their name is printed on the particular t-shirt's label. Since Threadless' opening, over 400 winning designs have been chosen for print from more than 35,000 submissions. The Threadless community is thriving with over 120,000 users signed up to submit, evaluate, score, and purchase new designs (Ogawa and Piller, 2006).

Unlike Threadless, that conducts its business almost entirely online, a Japanese company named Muji<sup>8</sup>, who is in the food, apparel and furniture business, did a little bit of everything in this business model. It sends post cards along with the product catalog soliciting improvement or new product development suggestions, sets up summer camps to invite customers over to experience Muji products first hand, and receives email and regular mail for such new information. It conducts an international competition that invites people to submit ideas and prototypes to Muji of products that combine value and quality standards. Further, every staff member on the sales floor

---

<sup>7</sup> [www.threadless.com](http://www.threadless.com).

<sup>8</sup> [www.muji.net](http://www.muji.net)

carries a little booklet, noting customer behavior or short quotes from dialogue with customers which are then relayed to the sales or marketing department (Reinmoeller, 2002). Customers' suggestions are gathered, processed, and evaluated in a structured process, ending in a short list of top ideas which are then discussed in a "business improvement meeting" by a management board including the company president. However, to face the new challenges in product development, they went further to apply the "customer commitment" method (Ogawa and Piller, 2006). Based on its own online community, Muji.net, with approximately 410,000 members, Muji asked its customers to submit their own new product concepts. The community would rank the designs, and Muji would create professional design specifications in order to estimate the costs, given a minimum amount of purchasers. If commercialization is considered possible, the refined design is published. The customers are asked to preorder and only after a minimum order quantity is reached does manufacturing and distribution start. If a concept failed to reach the preorder threshold, it is discarded. As a result, a number of products that Muji's customer co-designed generated sales far beyond the sales volume of comparable conventionally developed products. The most successful of these products is a kind of beanbag sofa chair which generated annual sales of 1,344 million Yen in 2004 (compared to 24 million Yen of average annual sales in this category) (Ogawa and Piller, 2006).

## 1.5 Open Design License

The free and open source software owes its current status to the birth of the GNU license. GNU, a recursive acronym, stands for “Gnu is Not Unix”, which was introduced by Richard Stallman in 1983. Over the years, the original content of the license was improved by removing ambiguous wording, and more terms were added for some specific free and open source projects. However, the core of the license remains. It has the following three freedoms. First, the freedom to copy the program and give it away to your friends and co-workers; second, the freedom to change the program as you wish, by having full access to source code; third, the freedom to distribute an improved version and thus help build the community.

The initial purpose of promoting free and open source software, according to the *open source initiative*<sup>9</sup>, is to develop methods for software that harness the power of distributed peer review and transparency of process. The promise of open source is better quality, higher reliability, more flexibility, lower cost, and an end to predatory vendor lock-in. As for the founder of the GNU license, Richard Stallman’s reason is straight and simple.

Here is his original word:

I consider that the golden rule requires that if I like a program I must share it with other people who like it. Software sellers want to divide the users and conquer them, making each user agree not to share with others. I refuse to break solidarity with other users in this way. I cannot in good conscience sign a nondisclosure agreement or a software license agreement. For years I worked within the Artificial Intelligence Lab to resist such tendencies and other

---

<sup>9</sup> <http://www.opensource.org/>

inhospitalities, but eventually they had gone too far: I could not remain in an institution where such things are done for me against my will.

The *Open Design* movement, which was inspired by the *Free and Open Source Software* movement, initially borrowed heavily from the GNU and Open Source Initiative for its own licensing agreement. However, Open Design is still at its young age and there is no universally accepted definition of this method, although several movements had set up examples, such as *open design definition* by the *Open Design Foundation*<sup>10</sup> and *open design license agreement* by *Society for Sustainable Mobility OSGV* (stands for open source green vehicle) project<sup>11</sup>. These are pioneers that found the benefit of applying the free and open source method in machine design applications. However, other researchers, such as Eric von Hippel *et al.*, started (almost at the same time) to realize that collective wisdom of the customer would benefit the established manufacturer to better understand the customer needs and provide more successful products. So, in the mechanical design domain, the open design method does not seek to replace traditional (closed) methods for developing tangible products. Rather, it is intended to improve the current method. For example, to disclose as yet unpatented designs should not require surrendering future patentability. Here, I think it is necessary to discuss the open design method and the role of patents in it.

If open design takes the form and license exactly analogous to open source software, then what the open design does is give up patent protection in exchange for two extreme goals. On the one end, it is for the common good, perhaps where funding or

---

<sup>10</sup> <http://www.opendesign.org/>

<sup>11</sup> <http://www.osgv.org/open-design-model/public-license/>

commercial interest is lacking, for developing countries or to help to spread ecological or cheaper technologies. A good example was Thinkcycle<sup>12</sup>, an open collaborative design platform for underserved community projects (Sawhney, 2003). At the other extreme, open design may provide a framework for developing very advanced projects and technologies that might be beyond the resources of any one company or country and involve people who might not otherwise collaborate. However, as we had discussed before, this is not necessarily the case. There are other means and goals of applying the open innovation with an established business. Dubiansky (2006) did a lengthy and comprehensive study on the role of patents in open innovation. His focus was on how established businesses use external forces to produce radical innovations and pointed out situations when such collaborations would be beneficial. He later concluded that the current legal regime is inadequate to fully develop these relationships and discussed the implications for patent policies (Dubiansky, 2006).

Sawhney (2003) identified intellectual property rights (IPR) patterns based on the level of public disclosure and formal/informal nature of the IPR desired. He described the key characteristics and rationale for adopting each of these patterns as follows:

***Informal-Public IPR:*** This is essentially a form of Open Source dissemination online, though no licensing mechanism is adopted. Most design projects on ThinkCycle are initiated in this pattern and at least a third of them remain in such status, primarily because the project is subpatentable or innovators have low stakes in the outcomes.

***Informal-Private IPR:*** Many innovators choose not to reveal all ongoing design experiments publicly until they have validated their findings. Hence they maintain contributions in private shared online spaces, while not seeking formal

---

<sup>12</sup> [www.thinkcycle.org](http://www.thinkcycle.org)



patents. Unless aspects of the designs are gradually disclosed, this IPR pattern can be considered the most extreme form of protection i.e. a Trade Secret.

***Formal-Public IPR:*** Some innovators when approached by companies to license their design innovations may choose to patent their work, even if previously disclosed, as long as it is within 1 year of disclosure. Innovators argue that by patenting, yet keeping innovations public they provide companies incentive for manufacture while being able to retain some control over the quality, specifications and usage of their innovations.

***Formal-Private IPR:*** A few innovators choose to keep their design concepts under private access, while seeking patents. This is primarily done when innovations are considered patentable and “above the radar” of commercial interests, such that protection becomes important. These innovators also wish to take a greater personal stake in the outcomes.

Innovators find themselves moving among these patterns over the lifecycle of a project, based on the nature of design outcomes and emerging patentability or personal stakes desired in an innovation. Hence we must consider the incentives and mechanisms that support diverse models of intellectual property rights, particularly among distributed participants of cooperative innovations (Sawhney 2003).

Among these four patterns, the *Formal-Public IPR* seems to have the flexibility and patentability best suited for open design activities. However the one year delay after disclosure for formal patenting is only viable for US patents. However, even without patents, business can still benefit from the “First-Mover Advantage” (Boldrin and Levine, 2005; von Hippel and Katz, 2002) and other benefits.

The relationship between current patent law and open design method is out of the scope of this research. What we have found out is that, although it has limitations, the current patent laws do allow room for open design projects to seek some form of patent protection. The burden of balancing between patent and disclosure rests heavily on the

project management and is closely related to the tools and platforms used in such projects.

## **1.6 Problems and Challenges Emerged from Current *Open Design* Practice**

The open design approach definitely has its potential advantage comparing to the traditional method in terms of satisfying customer needs and providing manufacturers higher product success rates. However, it does impose some challenges as well.

### **1.6.1 The Flat Control System**

The traditional design method is conducted in a closed system of hierarchical control. People perform their duty by complying with the request from their supervisor. In an open design project, the control system is flat. You can't expect people to do the things simply because you want them to. In a Crowdsourcing experiment of citizen journalism organized by *Wired Magazine*, the Assignment Zero (Howe, 2007), organizers initially set up scores of topics, hoping that the contributors would begin producing content. However, in the end, only those topics of most general interest went on to become a true Crowdsourcing project. One of the participants, Derek Powazek (2007) summarized this finding by stating: "Editors trained by school or experience are skilled in a closed system of hierarchical control. An open participation process can be difficult

for them to adjust to. People won't do what you say because you just told them to. You have to inspire them to want to participate.”

## 1.6.2 Managing the Crowd

Because there is no vertical hierarchy system imposed, managing community projects and activities can become a delicate and artistic job. Most people participate online to have fun, not to do work. The organizer and project initiator usually overlook this fact and the projects end abruptly when it is time to do the sometimes difficult and tedious work to put idea into reality. One good example is the famous Canadian Crowdsourcing company Cambrian House. In his letter responding to Eric Schonfeld's (2008) article, Cambrian House CEO Michael Sikorsky stated that: *“It would have been better to back great teams with horrible ideas because most of the heavy lifting kept falling back on us, or a few select community members. A vicious cycle was created leading all of us to get more and more diffuse... Trying to find people **willing** or **capable** to take on the offspring (our outputs) of the CH model was hard and/or incredibly time consuming.”*

A similar situation was also observed during *Assignment Zero* (Howe, 2007). Initially, the organizer aimed at producing 80 feature stories and the setup of a website to house these 80 topics. However, they didn't assign editors in each topic right away. As Howe summarized:

The net effect was to put the organizational onus on the volunteers themselves. Baffled by the overarching concept of Crowdsourcing, confused by the design of the website and unable to connect directly to a manager or organizer, most of

the initial volunteers simply drifted away. “What we learned,” says Rosen (another Assignment Zero organizer), “is that you have to be waaaaay clearer in what you ask contributors to do. Just because they show up once doesn’t mean they’ll show up over and over. You have to engage them right away.”

Another participant, Derek Powazek (2007), had a better assessment of this. He argued that “Start with clear, simple tasks. This isn’t because the crowd can’t handle complicated ones - they can - it’s because they haven’t decided if it’s worth doing them for you yet. You have to earn that. And you earn it by letting them do something small and simple, have a good experience, and then move up to the next, more complicated task.” He further pointed out that “Crowds are very good sources. People are happy to go out and gather viewpoints, or post their own, because it’s social. ...and give the crowd tasks that are, frankly, more fun to do.”

### **1.6.3 The Effect of “Ghost Town”**

If the community is not managed well, or the community member is frustrated, it is very likely that the community would shrink or die eventually. This happens a lot in online communities, especially when the community is self-governing. Later I will describe how such an effect happened in our experiment, which was not a pure flat control system, but was almost self-governing. What happened was that people were “afraid” to take the first initiative, even though they know very well what they were expected to do. When a project was kicked off and the community members were well informed with the task they need to perform, interestingly in several cases none of the members took the first step. The project forum looked like a “ghost town”. Such incidence happened

in the *Assignment Zero* as well. It seems to us that the community needs a leader, either assigned like what *Assignment Zero* did in a later phase of that experiment; or one that would emerge internally like what happened in some of our experiment teams. More detail will be discussed in a later chapter.

#### **1.6.4 Obstacles of Implementing Open Design Method**

The advantage of using an open design method is clear and simple; however, implementing it with an established business is no easy matter. Franke and Schreier (2002) cite Christensen (1997), noting that he specifies several reasons for this problem, ranging from cultural and psychological factors (arrogance, bureaucracy, short-term thinking, etc.) to economic aspects (high fixed costs forcing companies to focus on large markets only, reluctance to turn past investments into sunk costs, etc). Another obstacle is that established companies have branding strategies and corporate images to uphold. Customers' innovation may not agree with these. Thomke and von Hippel (2002) stated that resistance could come from sales and marketing departments. One advantage of open design is that customers who are able to design products themselves have little need for a manufacturer's sales or marketing department to determine what they need. Hence it will affect the compensation of sales representatives in the field, or the job security of the marketing analysts. Other factors come into play in this kind of resistance as well, such as the research and development department. Customer innovation as an external technology usually would be treated with an attitude of “ ‘not invented here’ and would result in foot dragging, passivity, feigned acceptance, hidden

sabotage, or outright rejection in the implementation and use of such knowledge” (Katz and Allen, 1982).

As a result of such difficulties for established businesses, it is natural to draw a conclusion that new ventures and entrepreneurs would be a better fit to explore these opportunities. However, as warned by Franke and Schreier (2002) and shown by the failed new startups of open design method practices, entrepreneurs faces their own, maybe bigger, problem of implementing this new method. This is precisely where our research is focused.

## **1.7 Research Plan for OCD Method Emphasis on Mechanical Engineering**

Initially, my research plan was to conduct a series of open design projects with increasing openness in hope of finding the correct recipe for conducting open collaborative design online. This was necessary when this research was initiated in 2006. At that time, there were not many open design efforts we could reference. However, things changed quickly from 2006 to 2008, during which numerous business entrepreneurs implemented such methods (in some way) and I started to find the research interest had shifted from establishing an anecdotal example of OCD to the comparison of OCD with more traditional design methods. Those pioneering businesses provided many successful stories and also exposed some obstacles of

applying such methods. Focusing on those obstacles became more important than studying and promoting this new design method.

As we have discussed above, it is our interest to explore the difference between the open collaborative design method versus traditional “closed” method in terms of productivity, satisfaction, as well as the problems and solutions that may emerge along the way. To thoroughly compare OCD with closed methods, we intended to apply the OCD method to all six phases of the generic product development process defined by Ulrich & Eppinger (2003) in open collaborative setups. However, due to resource constraints and the goal of simplifying the research activities to a manageable level, we argue that we can compress them into three phases. The planning and concept development phase share similar characteristics with brainstorming approaches; the system design and detail design phase all involve embodying a concept into models and subsystems that need significant calculations; the prototyping and production all concern making a design into a tangible artifact. Hence, we setup three experiments to cover the entire process: Conceptual, Embodiment, and Prototyping. Chapters 2 and 3 cover the conceptual design experiments, with chapter 2 describing a Pilot experiment; chapter 4 covers the Embodiment experiment; and chapter 5 covers the Prototyping experiment. In all, therefore, 4 experiments were completed. All were reviewed and monitored by the Washington University in St. Louis Human Research Protection Office.<sup>13</sup> All of these experiments used students as experimental subjects. As such, a useful byproduct of these studies is preliminary experience with introducing these topics

---

<sup>13</sup> HRPO Numbers X07-58, X08-0321, X08-1075

and tools with experiential learning approaches in engineering design courses. A possible problem is the amount of similarity between engineering students, and real-world practitioners of engineering design. This possible problem is addressed in several places later in the thesis.

### 1.7.1 The Three Phase of Product Design in an Academic Environment

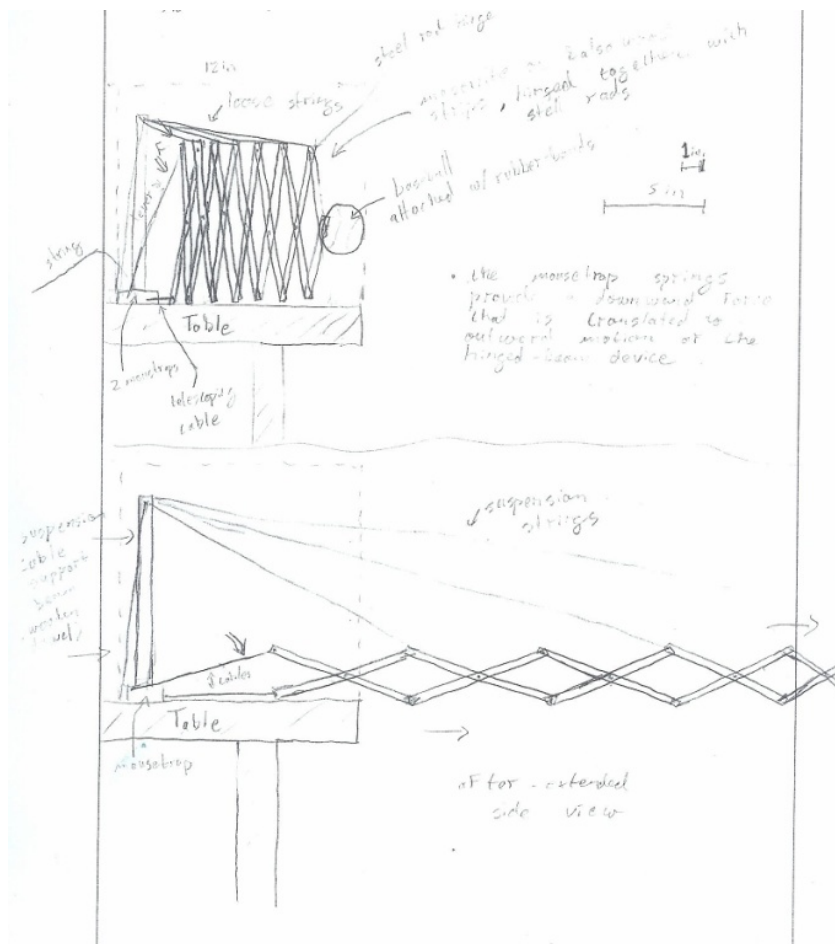

Figure 1.1 Concept Generation Sketch (example from 2008 prototyping experiment).



**Concept Generation:** At this phase, a design challenge is introduced. The student will be asked to design a product concept that would meet the design challenge, usually in the form of a sketch such as that shown in Figure 1.1. A brief explanation is usually delivered with the drawings to further explain the designer's approach. The sketch is usually drawn to the correct relative dimension but not required to be on scale.

**Embodiment:** In this phase, the students have a design concept to begin with. The challenge is to provide necessary engineering calculation and detail design of the subsystem or parts that would make the concept design work. Usually this involves static and dynamic analysis, catalog searching for standard parts, and detailed design of custom parts, along with material choices and stress analysis. An example of such activity is shown by Figure 1.2

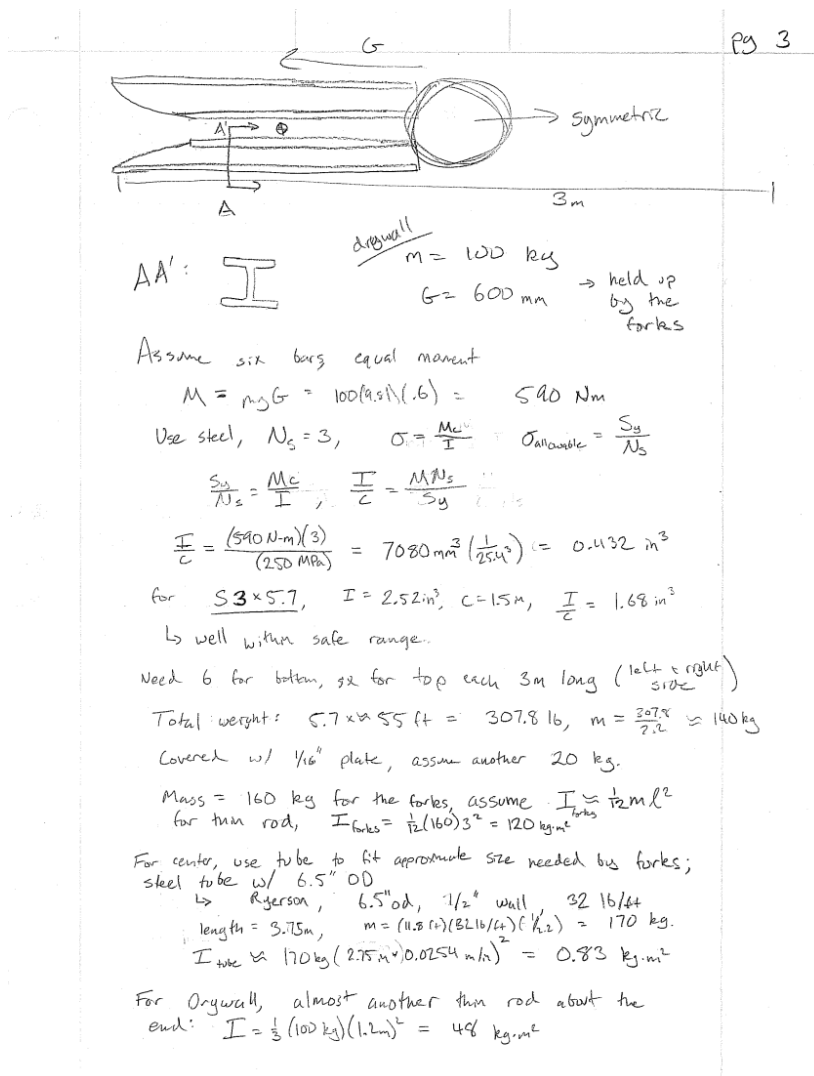

Figure 1.2 Embodiment Calculation Example (from the 2008 Embodiment experiment)

**Prototyping:** In this phase, the student usually has a detailed design to start with. However, our experiment was embedded with an existing class, so the students were required to provide concept sketches and embodiment design first before the prototyping experiment data collection started. Before designing, the students were given a set of materials that they could use. Figure 1.3 shows one of the prototype machines that the student built for the design challenge.



Figure 1.3 Prototype Machine (from the 2008 prototyping experiment).

## 1.7.2 Experiment Tool: Wedesign Forum

A common tool used for open design methods is the threaded online forum. We can find such a tool employed for users / participants to communicate with each other on many existing web sites, such as Cambrian House and Kluster for example. Some of them have more features for the ease of user participation. Innocentive, for example, has personal space for users to trace their activities within the community such as project involvement and interest areas. Most community websites have private message

functionality in case participants want to communicate privately to each other. Usually those websites would allow members / participants to upload and download project related files for free.

In the spirit of open design, we applied free and open source software for our research purpose. The forum software is phpbb2<sup>14</sup>, the web sever software is Apache and the online database is Mysql. The Wedesign<sup>15</sup> forum is shown in Figure 1.4

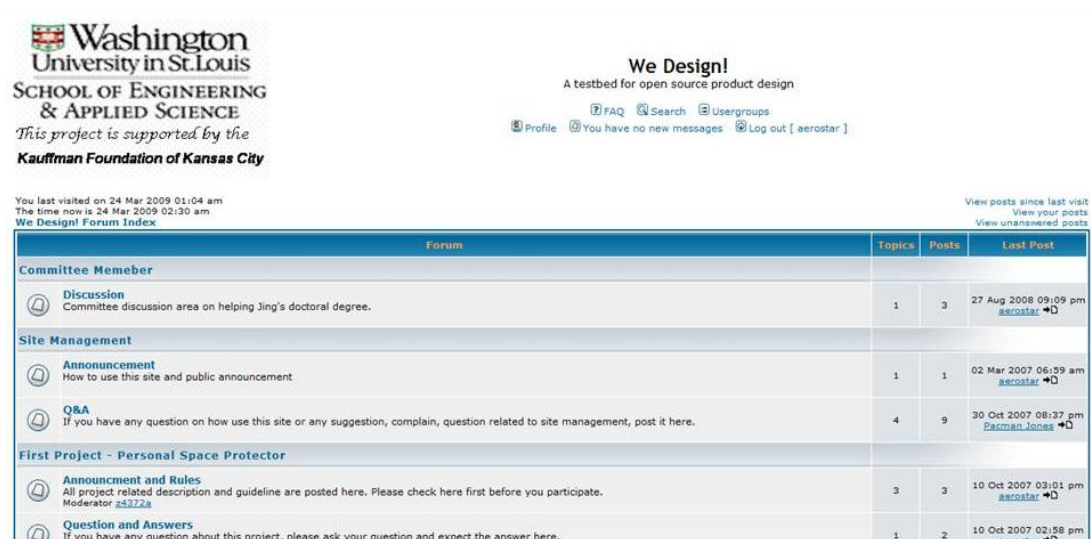

Figure 1.4: Wedesign Forum

Users have an alias and a password and can access the forum on the internet. All user input is in the form of a post, or a vote in a poll. A user typically would input a design idea by sketching it on paper, scanning it, and attaching the scanned file to a post. Users can append comments to a post, and make other posts without attached designs, say to

<sup>14</sup> <http://www.phpbb.com/>

<sup>15</sup> <http://Wedesign.me.wustl.edu/phpbb2>

request a clarification. Voting is done with polls. Users can set up a poll or respond to other polls before a stated deadline. The forum can be organized into sub-forums if several design problems are under consideration at the same time. Each member is assigned to their dedicated projects area and they cannot see the result of other projects. There are public announcement areas which can be accessed by all members for that project (see Figure 1.5).

The screenshot shows a forum interface for 'Design Entries'. At the top, there are navigation links: 'Customize Links', 'Free Hotmail', 'Windows Marketplace', 'Windows Media', and 'Windows'. Below this, the forum title 'Design Entries' is displayed, along with moderators 'designquv, z4372a, DeeWhiz, s1a2d3' and a user 'aerostar' browsing the forum. A 'new topic' button and a breadcrumb 'We Design! Forum Index -> Design Entries' are also visible. A 'Mark all topics read' link is in the top right. The main content is a table with the following columns: 'Topics', 'Replies', 'Author', 'Views', and 'Last Post'. The table lists various topics, including announcements, polls, and discussions, with their respective reply counts, authors, view counts, and last post dates and times.

Topics	Replies	Author	Views	Last Post
Announcement: Soft backpacking project status	0	designquv	85	18 Oct 2007 06:48 pm designquv
Announcement: Passed motions: what to do next?	1	designquv	90	17 Oct 2007 05:19 pm designquv
Sticky: [ Poll ] CSD-4 Please select the winner out of 7 design	0	aerostar	146	26 Oct 2007 01:18 am aerostar
Sticky: [ Poll ] CSD-3 Poll	0	aerostar	197	24 Oct 2007 04:53 am aerostar
Sticky: Summary of Parliamentary Method	0	aerostar	54	23 Oct 2007 03:15 pm aerostar
Sticky: Clarification: How voting works	0	designquv	41	17 Oct 2007 04:27 pm designquv
SO DON'T GO CAMPING...	3	Arnold Schwarzenegger	3169	24 Oct 2007 12:52 am chain lightning
A motion to view design concepts as they come in	2	mug987	36	18 Oct 2007 12:20 am wustl11
[ Poll ] Poll on to show attachment immediately after it is posted.	0	aerostar	136	17 Oct 2007 11:33 pm aerostar
Motions without seconds	0	designquv	19	17 Oct 2007 09:02 pm designquv
What to do next	1	COMMANDER HAAGEN DAZS	48	17 Oct 2007 08:06 pm WU_Student_2007
[ Poll ] Poll: subproblem according to first letter of alias?	0	designquv	131	17 Oct 2007 05:04 pm designquv
[ Poll ] Include a user need that combines the ability to carry more	3	aerostar	144	17 Oct 2007 01:48 pm aerostar
I move that we submit sections of solutions to be evaluated	10	Shakey Jake	145	17 Oct 2007 04:13 am WU_Student_2007
[ Poll ] Motion to piece the project into components	4	aerostar	181	17 Oct 2007 03:54 am Brwoner
[ Poll ] separate the Design Entries forum into several sub forums	1	aerostar	145	17 Oct 2007 03:00 am aerostar
Combining user needs	1	drichtm	74	17 Oct 2007 02:00 am umbrellaman
Parliamentary procedure	2	aerostar	66	16 Oct 2007 10:27 pm aerostar
A Motion to Divide and Conquer	2	iheart404n	146	16 Oct 2007 07:37 pm

Figure 1.5: Inside a Design Project

We did a Pilot experiment on Wedesign to check the forum functionality and robustness. Later we conducted our two main experiments to test the productivity between traditional face to face collaboration and threaded online collaboration. In the prototyping experiment, we didn't use the Wedesign forum due to the class format and classroom restriction.

## Chapter 2

# Pilot Experiments of Using Online Collaborative Tool: Wedesign Forum<sup>16</sup>

### 2.1 Introduction

Early experiments exploring online collaboration took several forms. To study electronic brainstorming, Gallupe *et al.* (1992) applied an electronic meeting-support system called the University of Arizona GroupSystem. It was a synchronized computer network system that allowed people to collaborate at the same time either in the same or different locations (Nunamaker *et al.*, 1991). As computer technology advanced, online bulletin boards, forums, video conferencing, and chat rooms became available for synchronized and asynchronous online collaboration. Meyers (2003), Suthers, Girardeau and Hundhausen (2003), and Ocker and Yaverbaum (1999) investigated the use of such systems for collaborative learning. The online design space Thinkcycle started primarily as a showcase for previously completed collaborative design results, and then later included a forum for members to exchange design ideas and discussions (Sawhney 2003). Most recent online collaboration groups and companies have developed their own proprietary software tools. These are almost all based upon

---

<sup>16</sup> This chapter is largely based on an ASME 2008 conference paper (Jakiela and Zheng, 2008). Large sections of that paper are excerpted and revised for use in this chapter. This use is with the permission of the American Society of Mechanical Engineers.

threaded online tools, namely *forums*, as their major collaboration platform. Example of such applications can be found in *Kluster*, *Cambrian House*, and *Crowdsprit*<sup>17</sup>, etc.

In order to investigate the efficacy of conducting online collaborative design with such tools, we designed two pilot experiments to test the functionality of the threaded online tools using our own forum WeDesign.

## 2.2 Experiment Method

### 2.2.1 Subjects

42 students enrolled in the senior capstone design course in the Mechanical, Aerospace, and Structural Engineering department of the Washington University in St. Louis served as subjects for this study<sup>18</sup>. Participation in the experiment was voluntary. If some students chose not to participate, they would be given an alternative task to make up the course credit that was associated with this experiment. Initially, all 42 students expressed their willingness in participation.

In its standard (traditional) format, students enrolled in the course would do both individual and group work. In the first part of the course students work individually on concept development, which includes background literature search, quantified

---

<sup>17</sup> [www.crowdsprit.com](http://www.crowdsprit.com)

<sup>18</sup> Washington University Human Research Protection Office (HRPO) study number X07-58

specification development, concept generation, and concept selection. When completed, each student presents their chosen concept to the entire class. After considering these presentations, students indicate which projects they feel should continue to the second part of the course. In the second part design embodiment occurs. This includes concept refinement, engineering analysis, documentation with CAD models, and prototype fabrication. Approximately 2/3 of the individual projects are culled. Embodiment is done by teams of 3 or 4 students.

The students were asked to use an alias name to make posts on Wedesign, and their real name should be concealed and should not be revealed in any way during the entire course of the experiments. This is to simulate the real world online community scenario, in which members usually use an alias name to communicate with each other.

### **2.2.2 Design Method: Control Mode**

The purpose of the control mode experiment was to see if we can simulate the standard (traditional) procedure of the design process using the online collaborative tool Wedesign.

**Method:** Our experiment focused on the concept generation and concept selection tasks of the first part of the course. In the standard (*non*-online) format, an individual student is required to generate **six** different concepts for their design problem. Along with drawing quality, these are graded based upon the feasibility of each concept and



how distinct the concepts are from one another. In the experiment format, students were required to generate only **one** concept for a single project addressed by the group, with the idea being that requisite variety would be obtained from the larger number of concepts submitted by the group. The second part of the assignment was to choose 6 designs from all submitted. The six concepts receiving the most votes from all participants became the six resulting from the experimental concept generation.

In the standard course format, an individual student selects one of their own six designs. This choice is supported by the application of quantified specification equations formulated earlier (we call them “happiness equations”). In the experiment format, participants were required to pick six designs out of the possible 42 entries, with use of “happiness equation” being optional. The thinking was that the group consensus would serve a similar purpose as evaluation with quantified specifications.

Importantly, in this mode, in order to make sure that the students come up with a design idea all by themselves, the designs submitted by individual students were not available for viewing and consideration by others until all designs were submitted. Put another way, no participant saw any other’s design until all designs were submitted. The effect of this was that participants created their design in isolation, uninfluenced by the work of others, just like they would do in the standard format.

## **Design Challenge: “Personal Space Protector”**

The design assignment for the control mode was as follows:

Protect your personal space. Design a NEW device that keeps bad people and bad things away from your immediate vicinity (your “personal space”). Within this general theme, it is appropriate to address a variety of specific problems. Some possibilities include:

1. Street crime protection
2. Dog attack protection
3. Child bully protection
4. Insulation from mass transit dirtiness
5. “Privacy providers” for use on airlines, trains, etc.

For any specific problem emphasized, a reasonable context will be assumed. E.g. a design that provides “street crime protection” should allow the user to be a pedestrian “on the street.” Suggesting that the user remain in a car at all times misses the point. Importantly, all designs must be passive: no firearms, weaponry, explosives, chemicals, etc. intended to harm the bad people or bad things will be allowed. This holds even if such things are used in self defense.

### **Deliverable:**

1. A concept attached to a post to the forum.

2. Vote on the best 6 designs that have been posted. A special voting mechanism is provided.

### 2.2.3 Design Method: Parliamentary Mode

**Method:** The purpose of the parliamentary mode experiment was to determine if an online community could modify rules and work procedures without an imposed management mechanism or authority. Since there is no management hierarchy, any changes to processes would require community consensus to proceed. Such decision making processes were done in the experiment using standard parliamentary procedures that are commonly used in meetings. In this mode, participants can change the way the concept generation process is done by using a parliamentary procedure. Using the forum, participants can make motions proposing to change how tasks are done. Motions must be seconded, discussed, and voted upon. If they pass, concept generation will be done differently. If no changes are implemented by the participants, tasks will be carried out according to the procedures of the control mode.

In order to ensure that the will of the majority will be carried out, we set the threshold of minimum participation at 25 out of 42 for a poll (vote) to be considered legitimate. If 25 or more vote, the motion is passed if 2/3 approve. For example, if only 25 vote, 17 must approve; if all 42 vote, 28 must approve. Importantly, with the minimal number voting (25), only 17 (out of 42) can dictate procedure.

## **Design Challenge: “Soft Backpacking Kit”**

The design assignment for the parliamentary mode was as follows:

It has been determined that a growth area for camping supply companies is so-called “soft backpacking.” This involves humans carrying all gear, for relatively short distances on fairly easy trails, to campsites that have running water. A typical Cub Scout campout at a Scout reservation is a good example. Parents and scouts arrive by car and gear is unloaded. The gear and food is carried as much as a mile or two, to the camp where tents are set up for the night. If the group moves on to another site, it is similarly not very far, and accessible by fairly easy trails. Although the camp sites are not accessible by car, some Scout reservations provide wheelbarrows and wagons to haul gear and food if the parking lot is not too far from the campsite.

Importantly, this type of camping is typically done by inexperienced, often first-time campers. A camping supply company client realizes that a bad experience on one of these trips could discourage a future customer. They are considering marketing a “soft backpacking kit,” with everything one needs for such a trip. Based upon the user needs described below, it is evident that some new, if not revolutionary, products are required.

Several campers were interviewed shortly after one of these trips. User needs are summarized in categories below:

1. Users wanted gear that would be useful for a range of camping situations: from right next to your car, to no more than three miles away. Some used high-end backpacking equipment, and were not very satisfied (see other user needs below).
2. There were some complaints about unpacking the car, and preparing for the hike, especially if it was done in the rain. In general, everyone wanted this process to be sped up. Since they were traveling a shorter distance, people wanted to carry more gear and food than they would if it was a more serious backpacking trip.
3. By far, most complaints were about tents.
  - a. They are too complex to set up, and take too long to set up. They have too many parts. Erecting one should be more like “opening an umbrella.”
  - b. You should be able to enter a bug-proof tent without the hassle of a long zipper.
  - c. You should be able to stand up straight, especially to change clothes.
  - d. The floor always feels cold and damp.
  - e. It is often very difficult to find a level spot to place the tent. A sloping floor is very noticeable (see sleeping user need category below).
  - f. A wet tent is misery. You often get wet on the inside, and you cannot pack up a wet tent.
  - g. It is difficult to control the temperature inside: too hot with the fly, too cold without it.

4. There were also a lot of complaints about equipment used for sleeping.
  - a. Air mattresses seemed to work best, but they take time to blow up, and time to deflate before packing.
  - b. Various foam mattresses did not provide much comfort.
  - c. A mattress on a slope is very noticeable, especially if your feet are higher than your head.
  - d. Most sleeping bags are too hot for typical summer camping.
  - e. There is often condensation on the inside of the tent, which can soak a sleeping bag touching it.
5. Some wanted a daily “wash.” Especially on a multi-day trip, several wanted a way to “freshen up.” This included just washing your face, and taking a full body bath/shower.
6. There were surprisingly few complaints about food. Most interviewees did not use “high-tech” backpacking food, and instead used normal grocery food that would not spoil. Some commented that they would like an improved method for cleaning hands (for food preparation) and utensils, etc.
7. Several mentioned safety and medical issues. There were several anecdotal stories about people with sprained ankles and minor burns that had great difficulty getting back to a car or base camp. Carrying an adult a mile or two is possible, but very difficult.

Create concepts for the “soft backpacking kit,” (either components or the entire kit) that was mentioned above. Internal Combustion Engine is not an acceptable part in the design.

**Deliverable:**

1. Some type of participation in the initial parliamentary process. Even if you just vote on a motion, you will get credit for this portion.
2. A contribution to the concept generation process. Typically this would be a single concept design. Depending on the process devised by the crowd, other creative contributions will be acceptable. These will be approved by the moderator. Importantly, to get full credit, you must make some type of creative contribution, rather than just voting, and making or discussing a motion.
3. Participating in the process to select the six designs. Even if you just cast a vote, you will get full credit for this portion.

## **2.3 Experiment Results**

In general, the system was well received by the students. Many commented that the experiment was an interesting experience, and two participants completed follow on undergraduate research projects related to the system since the course ended. A significant number (18/42) did not complete all of the work to earn the full 5% credit. Additional makeup assignments were provided to these students as makeup work.

## 2.3.1 Control Mode

**Concept Generation:** 39 individual designs were received from the 42 participants. 35 responded to the concept generation poll that sought to choose 6 from the 39. The “winner” got 11% of the vote. There was 3-way tie for second at 5%, fifth place got 4%, and there was a 3-way tie for sixth at 3%. 8 designs were therefore sent on to concept selection. Figures 2.1, 2.2 and 2.3 show three example designs submitted by three of the 39 students.

### Crowded Source Concept 1: Collapsible Shield

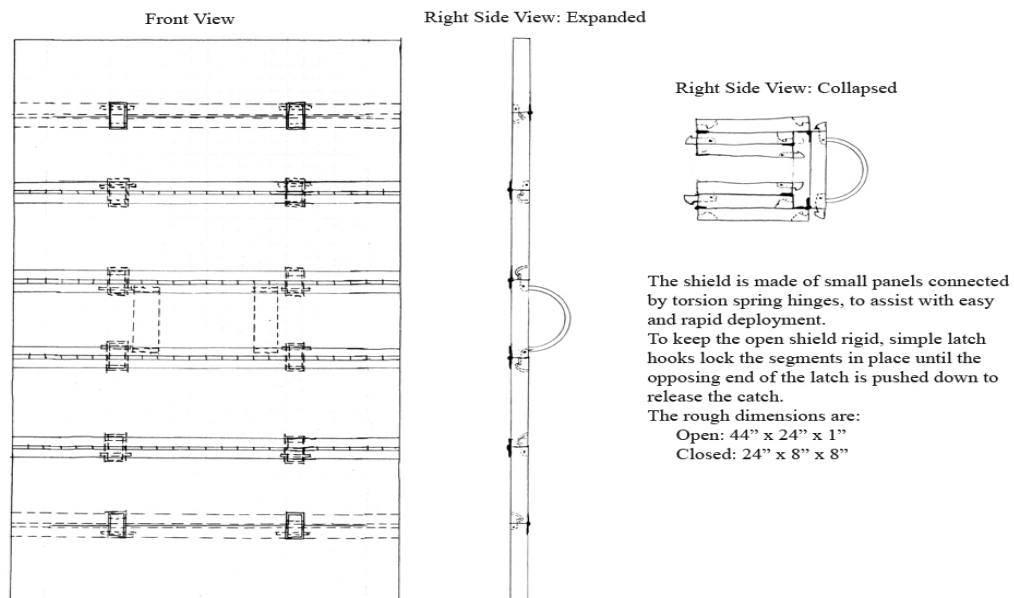

Figure 2.1: Design Concept: Collapsible Shield



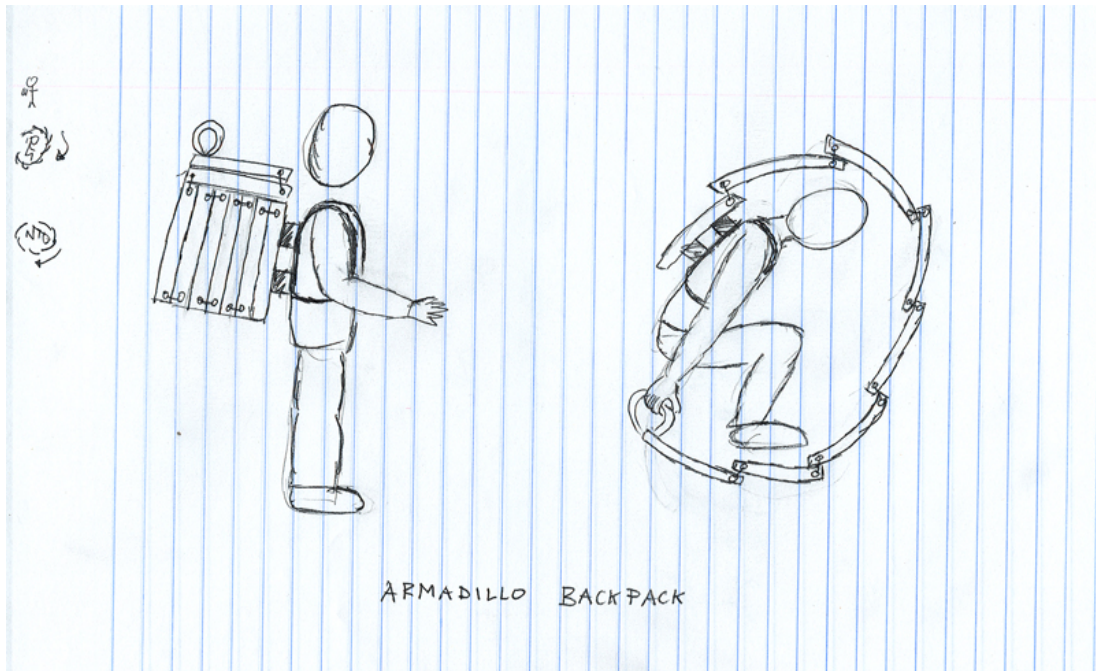

Figure 2.2 Design Concept: Armadillo Backpack

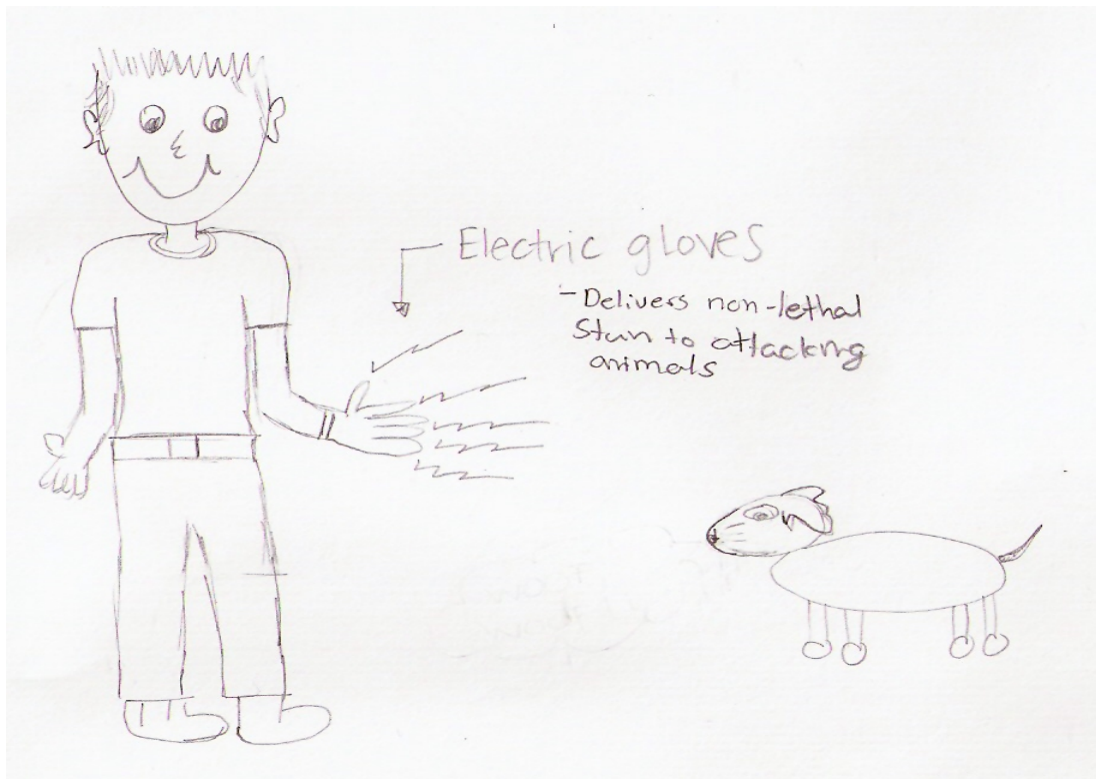

Figure 2.3 Design Concept: Electric Gloves

**Concept Selection:** All 42 participants cast votes in the control mode concept selection poll. The winner from among the chosen 8 designs from concept generation received 30% of the vote. This design, shown in Figure 2.4, depicted a simple waist belt with mace and an ultrasound source intended to be used to repel dogs.

### DogRepel v1.0

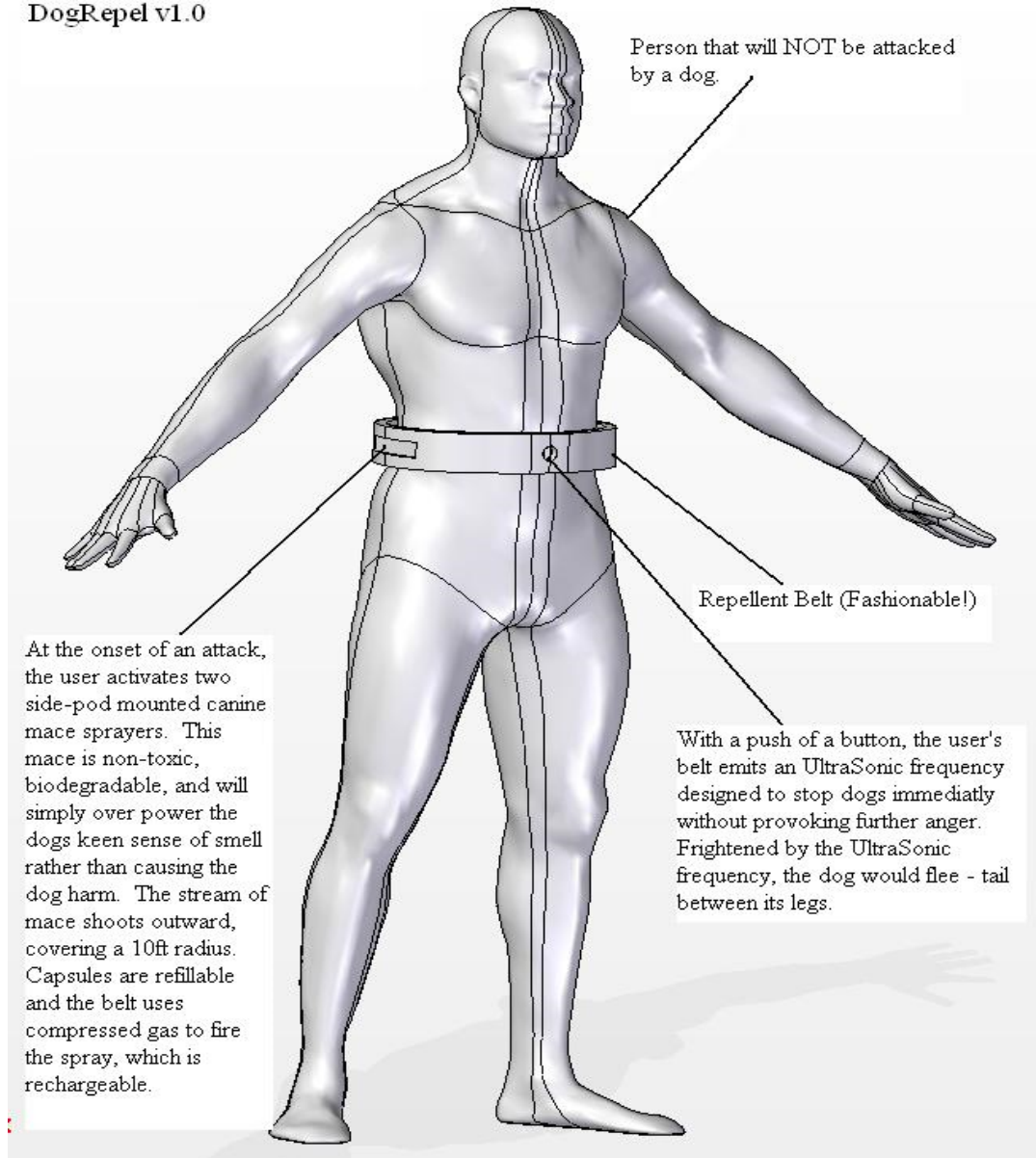

Figure 2.4 “Winner” Design: Dog Repel v1.0

### 2.3.2 Parliamentary Mode

**Concept Generation:** 6 motions were made during the parliamentary mode concept generation. 5 were seconded (i.e. lacking a second, one was not considered) causing polls to be generated. Three of these motions passed and became “law.” One was voted down, and one did not attract enough votes. Two of the passed motions dealt with administrative issues related to subdividing the overall problem into subforums. Enacting these allowed participants to make their submissions to specific subforums. Both of these were passed by wide margins. A related motion that would assign participants to a particular subproblem according to the first letter of their last name (thereby preventing them from choosing a subproblem) did not attract enough votes. A motion to add a user need clarifying the ability to carry a large load and carry an injured person was voted down. Finally, and perhaps most substantively, a motion to display submissions to all participants immediately as they are posted passed. This would allow a participant to review others’ work before making their own submission, thereby ending the isolation mentioned earlier. The summary of the motions can be seen in Table 2.1 shown below. The students then chose to generate design concepts for one of the six subproblems voluntarily. The distribution of the design concepts generated for each subproblem is shown in Table 2.2

41 submissions were received in the parliamentary mode concept generation. 35 votes were cast in a poll to pick the best 6 concepts. Voting was close, with first place receiving 7%, second 6%, a 3-way tie for third at 5%, and a 2-way tie for sixth at 3%,

yielding 7 designs overall. Figures 2.5 and 2.6 show some concepts generated in this mode.

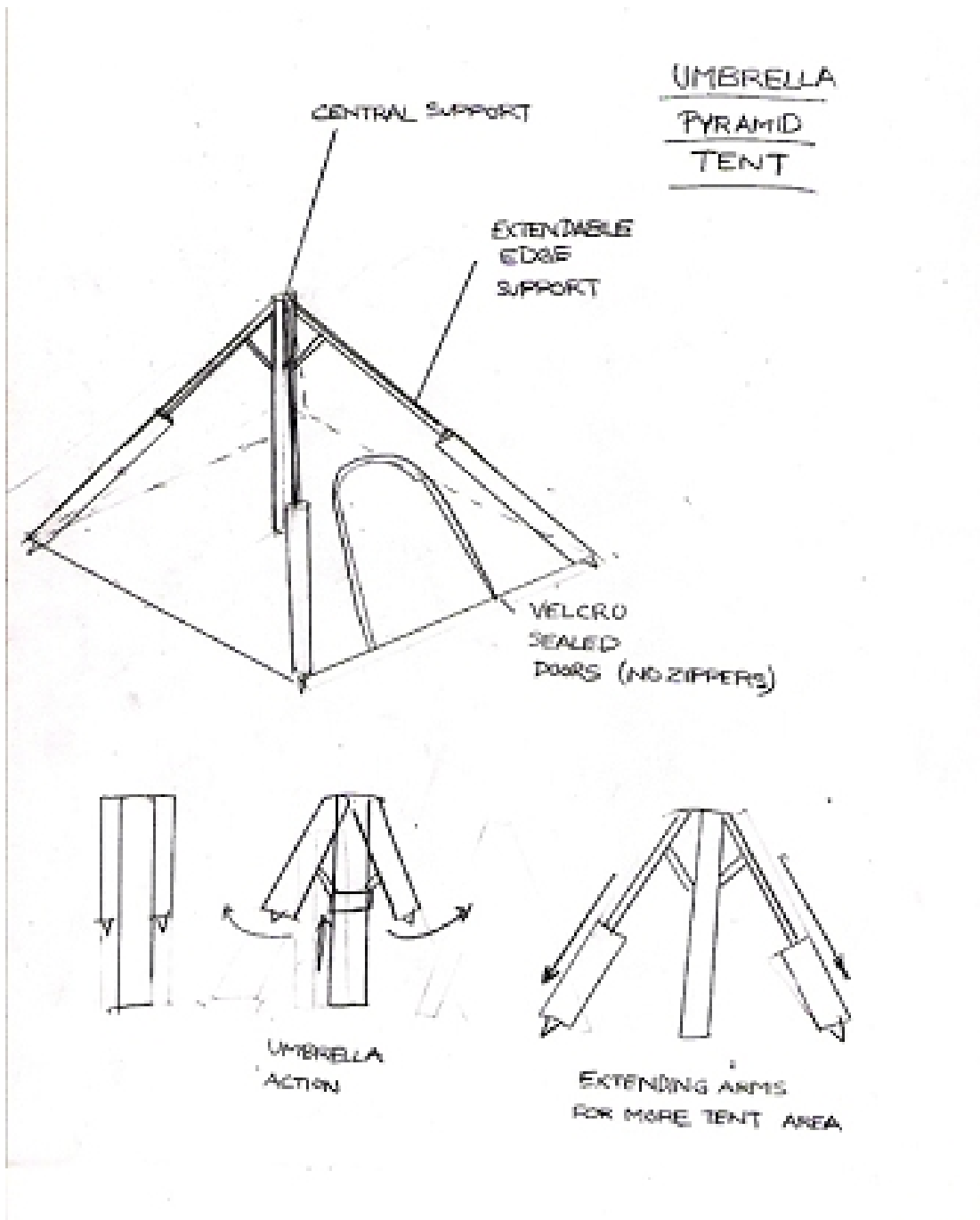

Figure 2.5 Design Concept: Tent

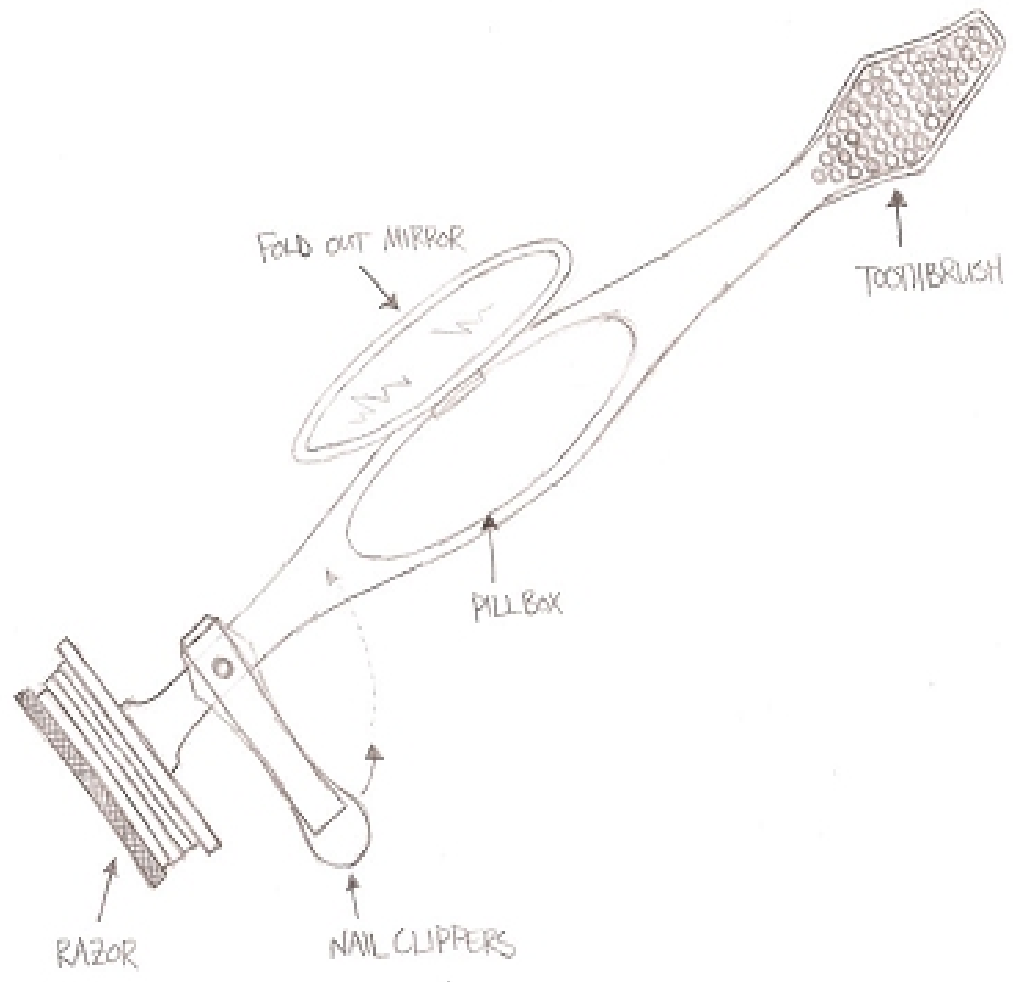

Figure 2.6 Design Concept: All-in-one “Freshening up” Tool Set

Table 2.1 Parliamentary Motions

Motion	Total votes	Yes	Not	Accept / deny
Motion to piece the project into components	25	23	2	Accepted
Separate the Design Entries forum into sub forums	26	24	2	Accepted
Poll on to show attachment immediately after it is posted	26	19	7	Accepted
Participants should be assigned to sub-problems according to the first letter of their aliases	16	11	5	Denied
Include a user need that combines the ability to carry more material with being able to carry an injured person	24	11	13	Denied

Table 2.2 Concept Generated for the Sub-Problems

Tent	Sleeping comfort	Freshening up	Cleaning hand & food Prep	Medical / Safety issue	Integration / Packaging
18	14	4	1	4	4

**Concept Selection:** No motions were made in the parliamentary mode concept selection process. 36 votes were cast to pick an overall winner that received 30% of the vote. The winner design is shown in Figure 2.7

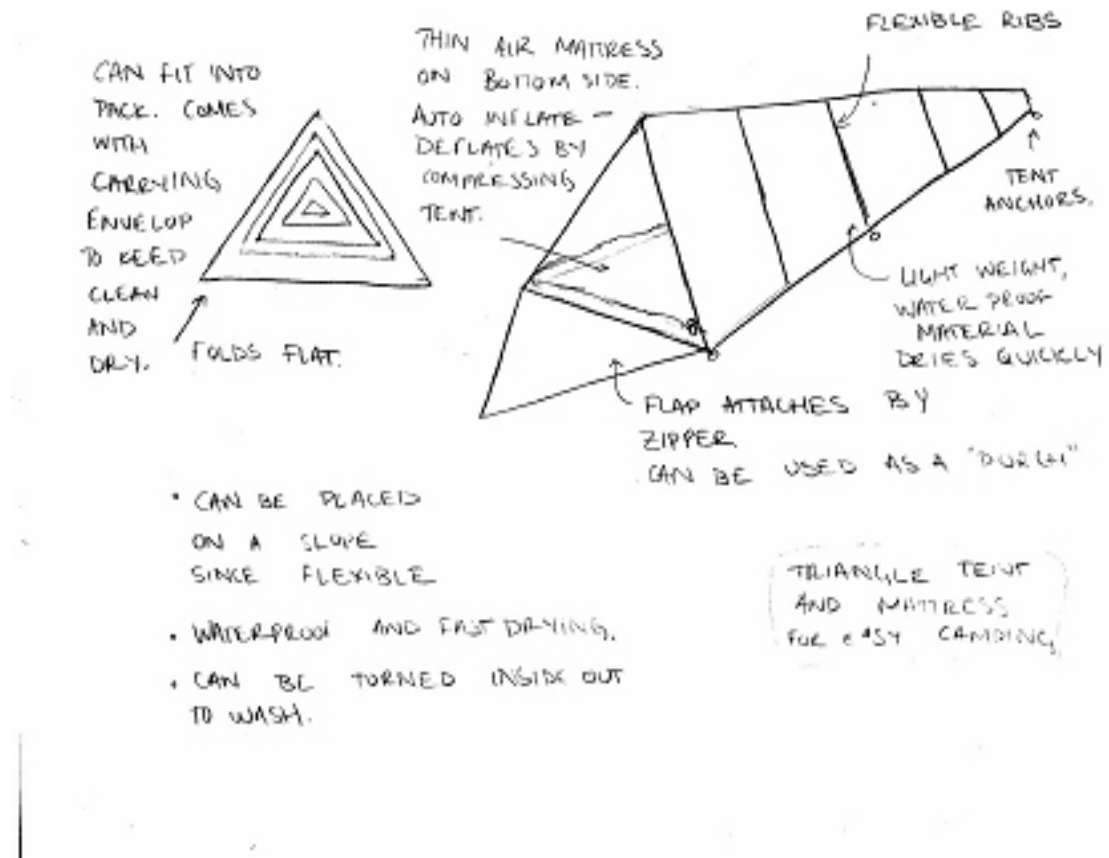

Figure 2.7 Parliamentary mode concept winner: "Tent"

## 2.4 Survey Results

### 2.4.1 Control Mode

**Concept Generation:** The survey questions dealing with the control mode concept generation, along with aggregate number of responses were as follows:

Q1. Overall, including thinking, drawing, scanning, and interacting with the forum-based system, did you spend more or less time than on the concept generation deliverable (of other projects that you did on the other part of the course, namely “D4”) that you did earlier individually? How much time for each?

Less time: 32; More time: 2; Same: 2;

The time spent on our control mode ranged from 15 minutes to 2 hours. The time they spent on D4 ranged from 1 hour to 10 hours.

Q2. Which do you prefer for concept generation? Working individually as you did earlier, or working as a member of a crowd in the control mode of concept generation? Please comment.

Control: 23; Individual: 10; No preference: 3



The majority of those in favor of a crowd mode expressed that less work load was the biggest reason. others mentioned that it was fun factor and was more similar to an industry approach.

Those in favor of an individual mode expressed a fear that the crowd mode promotes “free riding”, and that people would work harder on individual mode and produce better results. Some people thought that the crowd mode was overly complicated and confusing.

We fear that some people may have confused the Control crowd mode experience with the Parliamentary crowd mode, since a single survey covered both parts of the experiment.

Q3. Given that you only had to come up with one idea, did you explicitly try to make it novel or unusual? Please comment on your approach? Please elaborate on any other differences in approach or philosophy that arose in contrast to when you worked alone.

Yes, tried to make it novel: 15; No: 18; No difference 2

Many of those people who said “no” expressed that they simply made the very first idea that came into their mind their design submission. Others expressed that since there is only one design, they tried to make the design more feasible, hence not “crazy.”

Typical reasons for those who said “yes” are: “I tried to avoid obvious solutions”, or “cause I only have one chance”, etc.

Q4. How do you feel about the 6 designs that resulted from the crowd-sourced concept generation? Were they good designs? Was there enough variety among them?

Yes: 10; No: 3; Some of the design are good: 19; Have no idea: 4

Most of people, who either expressed Yes or No, agreed that there was variety among the designs. However, many pointed out that not all 6 design were good, commenting that some of them were “sloppy” or even unreal.

Q5. Did we do a good job in providing instruction in how this mode was going to work? what, if any, were the points of confusion?

Yes, a good job: 18; No, not a good job: 12; Not sure: 6

Many people who said “No” actually referred to the instructions for the Parliamentary mode, possibly indicating the same confusion mentioned above. The comments were mainly about site navigation and post content (that it was hard to read, e.g.).

One thing we need to keep in mind is that when we introduced the experiment, we asked for a show of hands in response to the question “how many people are familiar with forum based discussion?” We counted only three hands in response.

**Concept Selection:** The survey questions dealing with the control mode concept selection, along with aggregate number of responses were as follows:

Q6. Did you bother to use the happiness equations that were available (requiring you to estimate values for metrics) when choosing one of the six designs? Why or why not? If you used them, please elaborate on your specific approach.

Yes: 0; No 35; Once 1

Some commented that there was no time or no need to do so. Some thought that happiness equations are subjective anyway. However, many of them commented that they were not aware they were even available on the forum.

Q7. Do you agree with the choice that was made by the crowd?

Yes: 17; No 12; Not sure: 6; No comment: 1

Some who said “no” expressed that people did not seem to be taking it seriously.

## 2.4.2 Parliamentary Mode

**Concept Generation:** The survey questions dealing with the parliamentary mode concept generation, along with aggregate number of responses were as follows:

Q8. Overall, including time spent on the parliamentary process, did you spend more or less time on the parliamentary mode concept generation or on the control mode concept generation? How much time did you spend on the parliamentary mode?

Parliamentary more: 17; Control more: 13; No difference: 6

The answer for the time spent on the parliamentary mode ranged from 15 minutes to 2 hours.

Q9. Which do you prefer for concept generation? Working individually as before, working in a crowd in the control mode, or working in a crowd in the parliamentary mode. Please explain your choice.

Individual: 8; Control: 12; Parliamentary: 18; No preference: 1

Many chose crowd over individual because they like to get feedback. Those who preferred individual expressed that the crowd mode is not serious and is less productive.

Q10. Do you agree with and support how the parliamentary process modified the control mode approach to concept generation?

Yes: 30; No: 4; No preference: 2

Although a majority of people said “Yes”, they did point out that some motions did not make sense, and they suggested that it would have been good to have more time to refine design ideas before voting.

Q11. Did you make motions and/or provide points of discussion during the parliamentary phase? (I.e. did you do more than simply vote during the parliamentary phase?)

Did more: 16; Did not do more: 20

Many expressed that they didn't have enough time to keep up with developments on the forum. Some felt that the motions were convoluted and misleading.

Q12. How do you feel about the six designs that resulted? Was there enough variety? Were they good designs?

Good designs: 15; Not good designs: 7; Enough variety: 15; Not enough variety 6;

Some designs are good: 7; Unsure: 4

Q13. Did we do a good job in providing instruction in how this mode was going to work? What, if any, were the points of confusion?

Yes, good job: 15; No, not good job: 11; Not sure 2

Lots of people expressed that they were confused in this mode. They had many questions during the process but failed to discuss it on the forum.

**Concept Selection:** The survey questions dealing with the parliamentary mode concept selection, along with aggregate number of responses were as follows:

Q14. Did you bother to use the happiness equations that were available (requiring you to estimate values for metrics) when you chose one of the six designs? Why or why not?

Yes: 0; No 36

Q15. Do you agree with and support the selection process that arose from the parliamentary discussion? Please comment.

Yes: 25; No: 4; Not entirely: 7

In fact, there was no parliamentary discussion about the selection process at all.

Q 16. Do you agree with the choice that was made by the crowd? Please comment.

Yes: 20; No: 8; Not sure: 2; No comment: 6

Many people pointed out that the design was not actually complete, because the winner only addressed a few user needs, not all of them. However, many people agreed that the winner was the best design for that subset of user needs.

Q17. Did you make motions and/or provide points of discussion during the parliamentary phase? (I.e. did you do more than simply vote?)

Yes: 15; No: 20; Unsure: 1

Actually there were no motions and related discussion for the parliamentary selection phase. So, those who expressed “yes” are somehow confused with this question.

One final question was related to the overall experience:

Q18. Overall, do you prefer using a crowd-based approach to concept generation and selection (any mode) or do you prefer working individually as before? Specifically, would you rather generate six concepts for the same design problem, or would you rather generate one concept for each of six design problems? Please elaborate.

Crowd and 1 concept: 25; Individual and 6 concepts: 6; Both: 2; Not sure: 2

Many people expressed that they liked to work on other people's ideas and refine them. However, the time allocated for parliamentary mode didn't actually allow them to do that. Another issue raised is that the parliamentary mode we chose unnecessarily complicated the design process. Some said we should lower the bar for passing a motion, others suggested that a motion needed more time to be developed before being put to a vote. Those are all very valuable thoughts.

## **2.5 Implication and Discussion**

By conducting these two experiments with our online collaborative forum, we now have confidence that a normal product concept design can be carried out online. In doing so, we also identified new problems and challenges that need further investigation in order to carry out the design process in a more productive manner.

### **2.5.1 The Size and the Content of the Design Challenge**

Two observations in the experiment made us concerned about the size and the content of the design challenge we employed in these two experiments. The scope of the control mode challenge was very wide and it is very hard to design one device that



satisfies all the user needs. Most of the concepts submitted only covered one particular user need. The size of the parliamentary mode challenge was also very big motivating the students to divide it up into sub-components. In doing so, the final integration of those chosen sub-components was neglected. Our experiment showed that with total democracy, the design project could run into anarchy. In traditional product development, it is the management team's job to divide a full project into components and there are dedicated managers controlling the progress and completeness of those components development as well as that of the whole project. As discussed in Chapter one before, the online community is a "flat" control system. There is no vertical hierarchy management system. How to manage an open product design project would be a good research topic. However, for the focus of our research on the open design methodology, this suggests that in our future study, it might be a good approach to resize a project into a level that can be handled by a single individual, even though it will be done by a group. At the same time, the content of the challenge should be simple and easily identifiable, so that the participants won't get confused or frustrated. In the further research activity discussed in Chapters 3 and 4, the challenges were somewhat specific on one aspect of an application area, and the application area itself was more practical.

## **2.5.2 The Size of the Team**

The nature of open design is that there is no limitation on how big the team could or should be. In our experiment, the whole class was a big team, except in the

parliamentary mode, where they were divided into six teams voluntarily. Some teams were well populated, as shown in Table 2.2. *Tent* and *Sleeping Comfort* had 18 and 14 members respectively, while *Freshening Up*, *Medical / Safety Issue* and *Integration / Packaging* only had 4 member each. *Cleaning Hand & Food Prep* had only 1 member. This led to abundant tent and sleeping comfort designs, with not enough designs of other sub-components.

Evidently, large teams led to “free riding” activities that were complained about by the participants in their surveys. Other researchers of innovation versus group size have similarly found that team collaboration actually made the performance suffer (Latané, Williams and Harkins, 1979; Diehl and Strpebe, 1987; Gallupe *et al*, 1992). Moreover, large teams usually meant a larger amount of input which would demand more time for each member to keep track of other people’s input. This could affect participant’s willingness of participation and commitment to the project. We used smaller teams for our later experiments, which are detailed in Chapters 3 and 4.

### **2.5.3 How to Address the User Needs?**

The aggregate responses to Q6 and Q14 show that user needs were almost never explicitly taken into account when choosing a winning design. Although all subjects had received prior course instruction in the importance of user needs, this result did not surprise us. Most people would find even informally testing 5-10 designs against a set of user needs to be a tedious task. It seems to us that, when interacting with each other,

people tend to draw their preference for a design by intuition. The question then becomes “how to address the user needs?” Would the traditional way of identifying user needs become unnecessary? Would communal intuition (the results of a vote) be good enough to capture the real user needs? This remains as future research.

#### **2.5.4 Would Design Drawing Quality Affect Community Choice of Design?**

In the control mode experiment, the winner design is actually a middling quality design (judged by the course instructor) with an impressive CAD drawing. This led us to suspect that the drawing quality, not the design itself, won the community votes. Yang and Cham (2007) concluded from their experiment that “no conclusive correlations were found between the sketching skills and design outcome and reviewer ranking.” However, when using the community as a whole to be the judge instead of external reviewers as done by Yang and Cham (2007) in their experiment, we highly suspect that “looks do matter”. This is somewhat in line with our suggestion in the previous subsection, that communities tend to judge by intuition, causing a design’s appearance to help to swing the vote. This would be an interesting future research topic.

#### **2.5.5 “Player” vs. “Watcher”**

The aggregate responses to Q9 (showing most prefer to work in one of the Crowdsourcing modes) and Q10 (showing acceptance of the actions of the crowd) seem

somewhat at odds with the responses to Q11 (showing that most only voted during the parliamentary mode). Two follow on questions seem to be suggested. First, do users value the ability to, as a group, design their own work processes (as they could with the parliamentary mode)? In particular, an experiment should be designed to measure the tendency of groups to take advantage of such possibilities. Second, will user groups of such systems naturally partition into subsets of activist (let's call them "players") and simply interested (let's call them "watchers") users? What will be the typical relative sizes of these two subsets? Will players spend more time using the system? Will players generally be responsible for most creative contributions to the system? Should the system operate in two modes: a relatively sophisticated mode designed for a relatively small number of capable players, and a simple mode for a relatively large number of watchers? An experiment should be devised to test if these two types of user groups emerge. Such a study would be different than the one described here because not all users would be required to make creative contributions.

### **2.5.6 Should Management Be Imposed?**

In the parliamentary mode experiment, the students failed to integrate the sub-project into a wholesale design proposal, despite the fact that some participants pointed out that it was needed. Timing was an issue because the deadline of the project was approaching and most participants felt that they may have done enough to earn the credit so nobody responded to the call. This phenomenon revealed the fact that in an academic project setting, the community member is not driven by enthusiasm. People

tended to do just enough to get by. Members of our research group have debated intensively whether we should impose project management mechanisms during these experiments and in future experiments. The final decision was not to. This is due to the fact that, as discussed in the first chapter, the real community control system is a flat one. There is little management hierarchy existing in real community projects. We have already lost similarity on the “passion” factor by using academic settings. We desire to keep the experiment project as close to real community projects as possible. As a research matter, we decided to try smaller teams in the future experiments, and introduce smaller design challenges. However, we expected such problems to emerge in real community projects as well. By dividing project tasks into smaller pieces, just like some companies did in non-collaborative Crowdsourcing practice, e.g. Innocentive.com (Lakhani and Jeppesen 2007), we predict that the demand for management intervention would be less likely. We *did* expect that some active students would step up and act as the leaders of the projects. However, in the academic setting, such leadership was not common.

## 2.6 Summary

From these two experiments, we found that by using the forum based online collaboration tools we can conduct a mechanical product design process online. I can claim that we achieved limited success of applying the OCD method on Mechanical Design and Product Development. Here are the things I found necessary for the OCD method:

1. A public accessible forum that allows posting, reply, upload, download, and voting.
2. Community member that are capable of taking on the design challenge.
3. A well defined or well elaborated design challenge, either coming from an established company or emerging from community interests.
4. Leadership.

However, we also identified possible obstacles that might hinder the open collaborative design approach. They are:

1. Lack of interest.
2. Lack of Leadership.
3. Lack of responsibility.
4. Lack of motivation.

Due to the limits of an academic experiment setting, there is no comprehensive way of eliminating these obstacles from our experiments. So it is really not possible for us to simulate real world community supported projects in our experiment. For the subsequent experiments, we shifted our effort from establishing the feasibility of the OCD method to the comparison of OCD and traditional methods, namely Face-to-Face within the concept generation and embodiment design of the product design process.

# Chapter 3

## Open Collaborative Conceptual Design for Mechanical Engineering<sup>19</sup>

### 3.1 Introduction

The “open source” method has demonstrated how collective wisdom can be used to solve complex software development problems (Raymond 2000), and such methods are beginning to find application in the development of tangible artifacts. Howe (2006) first coined this practice as “Crowdsourcing”; companies outsource their R&D or brainstorm process to the public (crowd).

There are many startup companies trying to harvest collective public wisdom to create hit products. Some have successfully done so. *Mophie*, which makes iPod accessories, has a hit product named *Bery*, an all-in-one iPod Shuffle case, bottle opener, cord-wrap, and keychain. The company designed it at 2007’s MacWorld conference in 72 hours with input from 30,000 customers, using software that was a precursor to *Kluster*<sup>20</sup>.

---

<sup>19</sup> This chapter is largely based on a paper submitted to the AIEDAM journal (Zheng and Jakiela, 2009b). At the time of thesis submission, this paper was still under review, and not yet accepted for publication. Additionally, several passages in this paper are excerpted and revised from an ASME conference paper (Zheng and Jakiela, 2009a). This use is with the permission of the American Society of Mechanical Engineers.

<sup>20</sup> [www.kluster.com](http://www.kluster.com)

According to the founder of *Mophie* and *Kluster*, Ben Kaufman, *Mophie* sold hundreds of thousands of the cases for \$15 each (Schonfeld, Feb 2008). However, not all those practitioner are that lucky. One of the pioneer Crowdsourcing companies, Cambrian House, stopped practicing its original Crowdsourcing business model and has become much less of a factor in this area (Schonfeld, May 2008).

The rationale behind this new method is twofold. Firstly, the usual breakthrough knowledge is coming from individuals in unrelated fields rather than from internal experts (Hargadon, 2003). Secondly, this knowledge, because it is in a different field, is often “sticky” and transferring it from one place to another is difficult and costly (von Hippel, 1994). Hence, it is logical to shift the innovation job to the customers and turn them into innovators (von Hippel and Katz, 2002). One company, Innocentive<sup>5</sup>, successfully connected such knowledge seekers and the public (potential solvers) (Lakhani and Jeppesen, 2007) and recently has expanded their business from Chemistry and Biology to other fields such as Physics, Mathematics and Computer science. Its business model is simple. The client companies post their challenge publicly to solicit for solutions, and reward the best solver with substantial monetary rewards (sometime it is shared with a group of solvers). Innocentive will charge the listing company with a fee and sometimes an extra charge equal to a portion of the amount that was rewarded to the solver.



Innocentive's business model is a successful one. However, it does not involve any collaboration, which usually is the method of choice for companies to conduct their product concept generation. After all, a product concept design is not a one-man job in most cases. It involves experts in various disciplines to work closely together. In the case of Innocentive, working with individual solvers lessens the chance of revealing secret intellectual property (Lakhani and Jeppesen, 2007). Although this is a legitimate concern, current United States patent law does protect publicly disclosed intellectual property for up to a year. Even without patent protection, those who are the first to introduce a new product tend to hold a "first mover advantage" (Boldrin and Levine, 2005; von Hippel and Katz, 2002). The community initiated product like *Bey* has shown that open collaborative product design does have the potential for financial success. However, the open design communities are not always successful in the same way. The *Assignment Zero* (Howe, 2007) and Cambrian House (Schonfeld, May 2008) are two good examples. This leads our focus to the productivities of the online open collaboration. We are curious whether the online open collaboration approach would match the traditional face to face (FTF) method in terms of productivity.

There is much research that shows that brainstorming, a technique usually used in product concept design, tend to be less productive with groups than correspondent nominal<sup>21</sup> groups. Latané, Williams and Harkins (1979) tested and concluded that for a maximizing, unitary, and additive task, the productivity per person decreases as the team size grows larger. They attribute this loss to what was called "social loafing". A similar

---

<sup>21</sup> Nominal group is not a real group. Its group member works alone and the group result is measured by the simple addition of all group member's individual results.

trend was also observed by Diehl, and Strpebe (1987) in their research comparing real and nominal group brainstorming productivity. They suggest that “production blocking” accounted for most of the productivity loss of real brainstorming groups. Mullen, Johnson and Salas (1991) found that the brainstorming groups are significantly less productive than nominal groups, in terms of both quantity and quality. He attributed this largely to social psychological mechanisms (e.g., self-attention vs. drive arousal). Gallupe *et al* (1992) further found that for group size greater than two, brainstorming groups using electronic communication would outperform face-to-face groups. The bigger the team, the bigger the difference in productivity. However, other research and practice suggest that, although possibly inefficient, brainstorming is a necessary technique to spark creativity. Kelly and Littman (2005) attribute IDEO’s success largely to the brainstorm technique they used in their product concept design and the rapid prototyping method they applied to test those concepts. Sawyer (Sawyer, 2007) revealed that creativity is always collaborative – even when you are alone.

What intrigued us from all of this brainstorming research was the task that those researchers used in their study. The brainstorming challenge conducted by Diehl, and Strpebe (1987) were largely political or policy related issues. Latané, Williams and Harkins (1979) were examining human physical actions such as clapping hands or shouting out loud. Our research task, however, is more related to tangible artifact design, which is more aligned with Kelly and Littman’s (2005) practices. More like Gallupe *et al.* (1992), we are interested in comparing the productivity in product concept design using face-to-face and computer-mediated groups.

There are different methods and formats that can be employed for online collaboration. These include text-based chat room or instant messaging (synchronous), texted and visual-based threaded online (TO) – also called discussion forum (asynchronous), visual-based video conferencing (synchronous), visual chat room (synchronous), picture and video clips (asynchronous), etc. (Ligorio, 2001). To study how crowds would perform design concept development on the internet, we chose the threaded online forum method for three reasons. First, the threaded online format requires very low level software and hardware support, thereby facilitating participation. Second, we believe that large numbers of participants will have to communicate asynchronously, both to manage user input and to provide user convenience. Online users will want flexibility in timing their contributions. Third, the threaded online format is the format of choice for the majority of current open source and crowdsourcing efforts.

## **3.2 Related Work**

### **3.2.1 Face-to-face vs. Computer Mediated Collaboration in Education and Learning**

We have found little research that specifically considers the productivity difference between face-to-face (FTF) and online collaboration approaches when applied to mechanical engineering design. However, there have been many studies comparing the results of these two approaches in computer mediated education and learning. Suthers,

Girardeau and Hundhausen (2003) investigated how “deictic roles of external representations,” can help participants revisit prior information. Studying a *synchronous* online setup, Suthers *et al.* suggest that integrating old and new information in an interactive, conversational manner is more difficult online due to the awkwardness of or lack of deictic affordances. Meyers (2003) found that using threaded discussions increased the amount of time students spent on class and that higher-order thinking can and does occur in online discussions. Ocker and Yaverbaum (1999) provided empirical findings indicating that asynchronous collaboration is as effective as FTF collaboration in terms of learning, quality of solution, solution content, and satisfaction with the solution quality. However, students were significantly less satisfied with the asynchronous learning experience, both in terms of the group interaction process and the quality of group discussions. Although our experiment is very similar to those described in these studies, its focus is on the contribution of design content, rather than pedagogical or educational effectiveness. Nevertheless, these studies did hint at what to expect from asynchronous threaded online collaboration.

### **3.2.2 Distributed or Co-located Teams Effectiveness Related to Interaction and Management**

Still other studies are concerned with the management of distributed and/or co-located teams in order to maximize effectiveness. Boutellier *et al* (1998) point out that with distributed teams, members should either know each other personally or develop team spirit (trust) before the start of a project. Once an atmosphere of trust has been built up

it must be continually fortified, as it drops off in the course of decentralized cooperation. Yang and Jin (2008) suggest that in student project teams, however, the co-located teams are more socially oriented, which may be detrimental to team effectiveness, while distributed teams appear to be relatively more task oriented.

### **3.3 Methods<sup>22</sup>**

There are many factors that could affect collaboration effectiveness. In light of the literature we have reviewed above, the goal of this experiment is to compare the effectiveness of collaboration methods in mechanical concept design, with the three methods being nominal, FTF and threaded online (TO). Hence, we want to eliminate other possible factors as much as possible.

#### **3.3.1 Subjects**

30 undergraduate seniors enrolled in the capstone design course in the Mechanical, Aerospace and Structural Engineering department of the Washington University in St. Louis participated. With the goal of learning how to use web-based collaboration tools, they received partial course credit for participating. These subjects, being seniors, have received relatively rigorous and comprehensive academic training in mechanical engineering design. Unlike an online design community, however, individual subject's desire to participate was variable. After all, they participated to earn part of the grade,

---

<sup>22</sup> Washington University Human Research Protection Office (HRPO) Project number X08-1075

not because they are interested in the project itself. However, all participants were given the choice of not participating and doing other work to earn the course credit. None of the participants chose to do so. Most of the participants used our threaded online collaboration tool, *Wedesign*, (Jakiela and Zheng, 2008) in previous courses, so they were familiar with it.

### **3.3.2 Experiment Setup**

In our pilot experiment of the online collaborative design (Jakiela and Zheng, 2008, and Chapter 2), our control mode experiment had users submit a single concept, and through a voting procedure the group made a selection of a single final design. In contrast, our parliamentary experiment, which allowed online collaborative work with a parliamentary procedure, was only partially successful. The community came up various concepts to tackle several aspects of the challenge, but failed to integrate them into a solid final result. Based upon the results of the Pilot study, we designed this experiment differently. The experiment was split into two phases. In the first phase, the subjects worked individually and were required to provide as many concepts as they could to solve a challenge. This phase was somewhat like our controlled experiment before, except this time, the subjects were required to submit hand-drawn sketches. Then, in the second phase, the subjects were divided into two groups: one for the FTF method, and the other for the TO method. Each group had 15 students and was subdivided into 5 teams of size 3, yielding a total of 10 teams. All 10 teams were asked to improve the existing concepts developed by their individual members earlier and to generate more

(as a group) if possible. This was also similar to our parliamentary experiment (in that we allowed collaboration), except we added FTF teams for comparison. Also, the task was focused on one element of a design and it was less labor consuming, so no integration was needed in the final result. This experiment was somewhat similar to those done by Paulus and Yang (2000), who combined individual and group brainstorming activities in order to lessen the negative effects of previously revealed problems such as production blocking and social loafing. Our design is motivated by the fact that we believe that it simulates how an asynchronous open collaborative concept generation would work: individuals would respond to a call for concepts by first creating them individually, and then posting them for review and improvement by the community.

We were conducting two experiments in sequence at the time. We did an *Embodiment* experiment (Zheng and Jakiela, 2009a) after this one, which compared how similar small teams perform embodiment design using forum-based and FTF modes. Those who were in the FTF group in this experiment would be in the threaded online group in the *Embodiment Design* experiment and vice versa. However, team membership between the two experiments was rearranged to ensure that no two team members had been in the same team in both experiments. In fact, teams for both experiments were assigned so that students that had significant collaborative activity in other aspects of the course were not put on the same team for either experiment. This was done to break any social bonds the students may have developed previously (see Yang and Jin, 2008).

Regarding choosing a team size, ideally, a size of 4 might be preferred, following from the results of many creativity vs. group size studies (Diehl and Strpebe, 1987; Gallupe *et al*, 1992). However, in order to use the relatively small number (30) of subjects most effectively, and have a large enough number of teams (5 for each mode), we chose a team size of 3. We did not choose a team size of 2, because a single non-performing subject would render a team not collaborative.

The mechanical concept development challenge, shown below, was given to all students. The subjects had two days to finish the initial individual concept. In the second phase, all teams had two weeks to finish this task. A survey was conducted after the experiment to learn students' satisfaction with this experience and obtain any suggestions from the subjects.

### **3.3.3 Concept Development Challenge**

The engineering challenge we assigned in this experiment was derived from a real world problem. Teams were asked to design a sub-assembly for a drywall manufacturing line. As shown in Figures 3.1 and 3.2, a drywall manufacturing line ends with single sheets of drywall being transported by a powered roller conveyor. The boards are 1200 mm by 3600 mm (oriented as shown in the top view) and 18 mm thick. The powered conveyor moves constantly (without stopping), causing the boards to move at 20 mm/sec. Spacing between each board on the conveyor is 200 mm. The height of the rollers at the end of the conveyor is fixed at 1500 mm.



The students were asked to design a “*stacker/distributor*”. This will accept boards coming off the end of the conveyor, and produce a neat (with edges aligned) stack on a pallet, 60 boards high. After the pile is made, a forklift will remove the pallet with the stack. As this happens, boards continue to exit the roller conveyor. Another stack is somehow begun on another pallet. When this second stack is completed, it is taken away, and a new “first” stack is begun, etc.

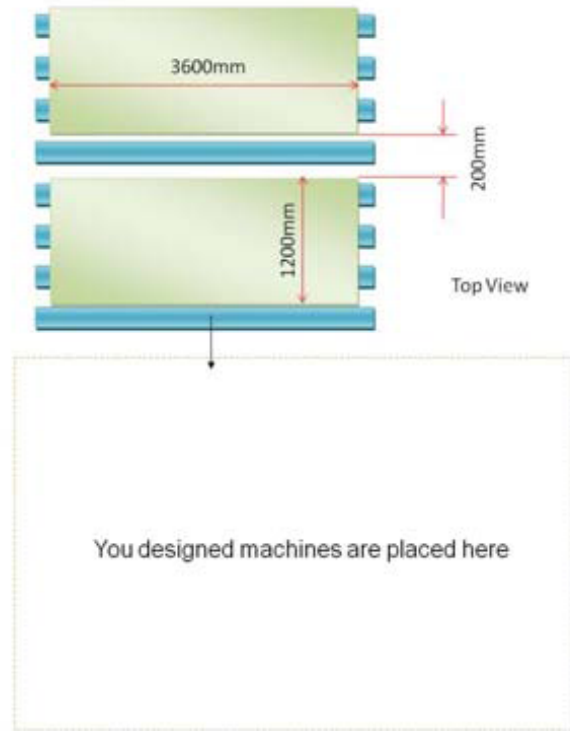

**Figure 3.1:** Top View of the Conveyor

Note that drywall is very heavy, very brittle, and very weak in bending. Extra care should be taken to make sure that boards do not crack, and edges do not chip during the stacking and distributing processes. On the side view, the stack can be located anywhere past the end of the roller conveyor, but you must allow access for a forklift truck.

Before the experiment started, students were informed that their grade would be affected by their work quality. As will be explained below, expert judges scored the work with respect to several criteria. This scoring did not influence the grade given to the students. As a practical matter, the grade actually earned by the students was most influenced by the degree to which they completed the experiment.

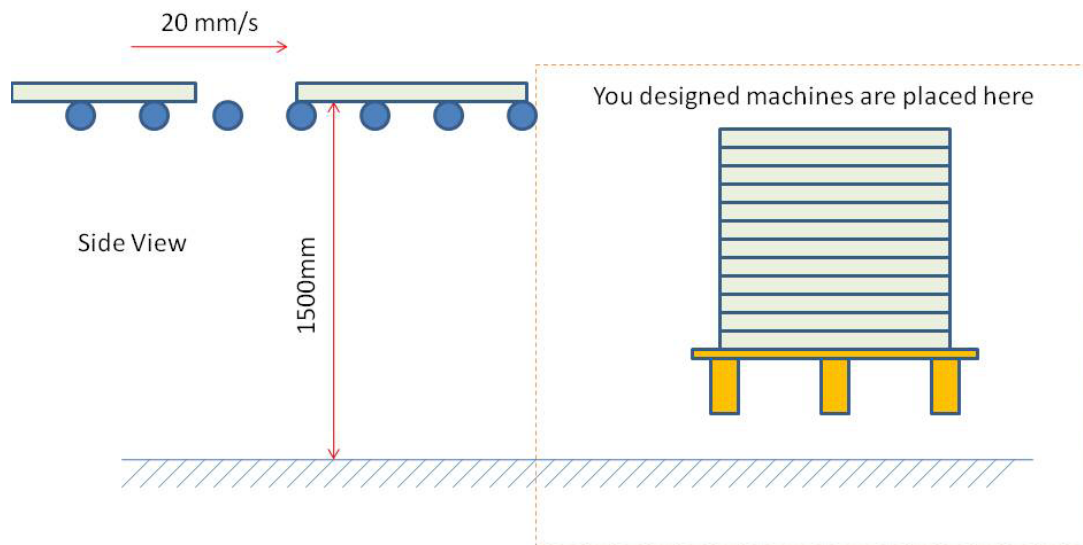

**Figure 3.2:** Side View of the Conveyor

**Tools:** We used a video camera to document all FTF activities. The FTF teams informed the researchers of their meeting times to allow this. The threaded online teams used the PHP-based forum software “WeDesign” (Jakiela and Zheng, 2008, and

Chapter 2). These subjects were requested to log on with an alias web name, and not reveal their personal identity to teammates.

**Hypothesis:** The hypothesis of this experiment is that, with all other conditions being equal as much as possible, the threaded online teams would perform equally well, if not better, than the FTF teams. And both group performances should be equal, if not better than the nominal group performance. Performance would be measured by the quality of the concept design work produced by each team. Specifically, three characteristics of the work (described below) would be subjectively evaluated by expert assessors.

**Independent Variable:** The independent variable is the design method, nominal, FTF and threaded online, used for conducting mechanical concept design.

**Dependent Variable:** The dependent variable would be the three characteristics that were assessed:

1. **Functional.** If a prototype were fabricated and debugged, would it function well? This is independent of how difficult it would be to fabricate and debug.
2. **Realistic.** Would it be possible to fabricate a prototype? Does the design use unproven approaches and uncommon materials? Is it likely that the design would ever work?
3. **Innovative.** Is the design clever and non-obvious?

## 3.4 Experiment Results

There were three groups, Nominal (NO), threaded-online (TO) and face-to-face (FTF). The first NO phase had ten virtual teams, five of them later became TO teams in the second phase, and the other 5 became FTF teams. In the end, all NO group submitted at least one design sketch, the most submitted by a group was six; all FTF teams finished their task and submitted at least three designs, the most submitted was five; only 3 out of 5 TO teams submitted at least one design, with the most submitted being four. The two non-productive TO teams did have members log on, but they failed to produce any significant results. We were mainly concerned about the quality of the designs, not the quantity, since both TO and FTF collaborations were based on their correspondent NO results (which served as input to the TO and FTF teams). We clarify here that identifiable designs produced by the FTF and TO teams were counted as “meaningful” if they were somehow different (i.e. not duplicated) from the designs created by the individuals in the correspondent NO teams.

Assessing a subjective merit introduces doubt of its accuracy. In the field of assessing creativity, or any other subjective matter, testing the reliability of the assessment is crucial for drawing convincing conclusions. Here, we applied a technique that is well established in the Psychology field: the *Consensual Assessment Technique (CAT)* (Amabile, 1982). This technique is used to judge design creativity in various forms, such as verbal and visual art products, musical creations, solutions to engineering problems, and other

tasks (e.g., Hennessey and Amabile, 1999; Amabile, 1982; Dollinger and Shafran, 2005; Fodor and Carver, 2000).

The design evaluation was initially done independently by *Three* external experts of mechanical engineering design. They were adjunct professors of the Mechanical, Aerospace, and Structural Engineering Department of the Washington University in St. Louis. The judges were NOT informed of a standard of how to judge the students' designs against the three criteria mentioned above. However, those judges, having taught and graded undergraduate mechanical engineering design courses, routinely evaluate student work with respect to such criteria. The finished student designs were presented to the judges in a random order and no two judges graded the designs in the same sequence. The student's identity and the team identity were all concealed to the judges.

According to Hennessey & Amabile (1999), given the consensual definition of creativity, the most important criterion for the results of this assessment procedure is that the product rating be reliable. Researchers originally utilizing the CAT relied upon the Spearman-Brown prediction formula. This technique yields results highly similar to the Cronbach coefficient alpha (Hennessey and Amabile, 1999). So the Cronbach coefficient alpha was calculated to test such reliability and a figure of .70 or higher can be considered evidence of an acceptable level of agreement among judges.

The initial result of the inter-judge reliability was not acceptable. We added one more judge but still couldn't get the reliability high enough. After adding a fifth judge, we managed to only get the reliability on the **Innovative** category above .70. The reliability figures are shown below:

Table 3.1: Inter-Judge Reliability vs. Number of Judges

Number of Judges	Innovative	Functional	Realistic
Three Judges	0.635	0.471	0.464
Four Judges	0.672	0.523	0.534
Five Judges	0.727	0.537	0.461

This shows that the five judges somewhat agree on the innovativeness of the subjects' designs, but disagree with each other on the functionality and realism parts of the designs. This is a rather interesting result because, intuitively, one might expect functionality and realism to be more objective, thereby increasing the likelihood that judges would agree on their assessments.

While Amabile (1982) found that in rating works of fiction, art, and poetry, expert judges obtained high levels of inter-judge reliability along several different dimensions, Fodor and Carver (2000) obtained results similar to ours. When they applied the CAT to engineering problems, they found that judges had strong agreement on dimensions that they called "creativity" and "complexity." They go on to report that "when applied to engineering problems, the remaining dimensions disclosed by Amabile's analysis did not prove to have sufficient inter-judge reliability to have utility" (Fodor and Carver, 2000). Due to this problem, only the Innovative analysis results are discussed below.

Understanding why other dimensions such as functionality and realism do not obtain assessor agreement remains as a future research topic.

The experiment results of the NO teams versus the corresponding TO and FTF teams in the form of mean and variance as well as the F-test and two-tail T-test results are shown in table 3.2. The FTF versus TO comparison is shown in table 3.3. Innovativeness was scored on a 0 ... 5 scale.

Table 3.2: Real Team vs. Nominal Team Results

Real team vs. NO team	Innovative Mean	Innovative Variance	F-test	T-value*	P-value
FTF 1	3.87	0.053	Equal Variance	-0.87	0.408
NO <sub>FTF</sub> 1	4.09	0.158			
FTF 2	3.04	0.048	Equal Variance	-3.81	0.0025
NO <sub>FTF</sub> 2	3.6	0.08			
FTF 3	3.2	0.38	Equal Variance	-1.07	0.306
NO <sub>FTF</sub> 3	3.54	0.320			
FTF 4	3.33	0.013	Unequal Variance	0.41	0.692
NO <sub>FTF</sub> 4	3.24	0.478			
FTF 5	3.95	0.037	Equal Variance	0.31	0.760
NO <sub>FTF</sub> 5	3.89	0.131			
TO 1	3.8	0.28	Equal Variance	1.80	0.099
NO <sub>TO</sub> 1	3.18	0.271			
TO 2	2.8	N/A**	N/A**	-1.47	N/A**
NO <sub>TO</sub> 2	3.27	0.91			
TO 3	3.05	0.01	Unequal Variance	0.19	0.853
NO <sub>TO</sub> 3	3	0.453			

\*: A negative number means the nominal group performed better in terms of innovative mean score.

\*\* : The TO 2 team only generated one more meaningful result out of its NO 2 input, hence it does not have variance and cannot be tested.

Table 3.3: FTF vs. TO Results

FTF vs. TO	Innovative Mean	Innovative Variance	F-test	T-value	P-value
FTF	3.43	0.25	Equal Variance	0.62	0.540
TO	3.3	0.26			

As we can see from these results, the difference between real groups and their nominal groups are not significant, except for the FTF team 2 and its nominal team, where the nominal team is significantly better than the FTF team. The difference between TO team 1 and its nominal team is not significant but it is close. The difference between the FTF and the TO teams are not significant, which means the online collaboration can generate similar results as the traditional face to face team.

### 3.5 Survey Results

We distributed 30 surveys at the end of the experiment, but only managed to retrieve 10 back. Among them, 6 belonged to FTF team members, and 4 belonged to TO team members. Although this is a very low response rate, we mention here some interesting results.

One question asked if participants had difficulty expressing their ideas to teammates. Only one FTF member said she did, and it was with regard to a design she did earlier individually in the nominal phase. Two TO team members reported that they did, one



with two designs done earlier individually, and the other with one design conceived in the collaborative team phase.

Another question asked if any ideas were lost or forgotten during the team phase. All surveys reported that this did not happen.

Another question asked if any participants were afraid to express their ideas to teammates. Again, no survey responses indicated this.

A close examination of the video tape we recorded for all the FTF team revealed the following incidents:

1. Team 1 collaborated very evenly. All members were actively involved and ideas were discussed in detail. They generated a total of 3 new ideas and they were all relatively good quality.
2. Team 2 collaborated evenly but passively. There was not much communication and their session finished relatively earlier than the other FTF teams. They generated a total of 5 new ideas but the average quality was low. One member seemed active but was slowed down by other two.
3. Team 3 collaborated unevenly. Two members had a very rapid discussion; the third member seemed to be left out. They generated a total of 5 new ideas. The average of the ideas' quality was low.

4. Team 4 collaborated evenly but passively. They had a brief communication with each other regarding their earlier individual ideas, and then went on drawing new ideas separately. They generated a total of 3 new ideas, and the average quality was low.
5. Team 5 collaborated evenly and extensively. Members took turns drawing their ideas on a board and discussed them with each other. They generated a total of 4 new ideas, of very good quality.

It seemed to us that there was one incident of “social loafing” (team 3). However, it was not because the subject was trying to avoid participating, but because the other members unintentionally left him out. Overall, “production blocking” seemed to not be present.

### **3.6 Implications and Discussion**

As shown in the tests results, the differences between the mean of the threaded online method and that of the face-to-face method are *not* significant. This means the results from the two methods are statistically equal. However, it is not enough to conclude that the threaded online method is as good as the face to face method in terms of productivity, if we consider the following observations:

### **3.6.1 The Rate of Participation**

As typical college students, our experiment subjects chose to do this task at the last possible moment before deadline. This might be OK for FTF teams, because the collaboration task only takes an hour or two. However, for the TO teams, due to the asynchronous nature of the collaboration, it usually takes a longer time span (not necessarily takes more time for the task itself) for team members to communicate as much as needed to complete the task. By delaying starting, those TO team members discovered that they did not have enough time for the asynchronous communication. Many of the TO team members did nothing more after posting their individual designs online, either because they ran out of time, or because they didn't log onto the system frequently enough. One TO team surprised us with the way they overcame this problem. Sensing that they were out of time, one member of the team proposed to the other members to be online at the same time so they could collaborate more quickly. The other two members agreed. They finished the task after about 35 minutes of online "pseudo-synchronous collaboration." At the other end of the performance spectrum, however, there were two TO teams that failed to deliver any additional designs over and above those they had already done individually.

### **3.6.2 The Rate of Collaboration**

Other than the team mentioned above, only one other TO team had some collaboration to get the job done. The other three TO teams had little or no collaboration at all. One

member in one of these three teams did an additional design alone, so it is counted as team results, even though the team had no collaboration. The other two didn't generate any additional designs. Overall, the rate of collaboration in TO teams was very low. All FTF team, however, collaborated closely.

### **3.6.3 Group Size Effect**

As stated before, the test subjects we used in this research were college students. Most of them had used the WeDesign forum before, so they were familiar with it. In earlier more informal use of the forum, an entire class participated as a single group. The overall collaboration was typically high and productive. Many individual students took initiative and pushed projects forward. However, in this experiment, the team size decreased dramatically. We wonder if the failures described above were due to the possibility that those student who naturally "lead" tended to not distribute evenly, or there were just not enough to have one on each team. It would be interesting to find out how many team members are needed to allow at least one "leader" to emerge. From our experiment, three is definitely not enough.

### **3.6.4 "Playing" versus "Watching"**

It caught our attention that in the TO mode, there were some subjects who worked very hard even when teammates did not participate, while some other subjects just waited for others to act first so they could provide comments in response. Of course, simply

providing commentary is much less taxing. This leads us to consider whether we should divide online participants into two groups: one we will call “player” and the other we will call “cheer leader”. A similar division already exists in some web-based companies that seek content and feedback from crowds. The T-shirt printing company *Threadless*, for example, rewards two kinds of participants. One submits T-shirt designs in the hope of getting a cash reward; the other votes on the candidate designs. The cash and/or points rewarded differ greatly for these two kinds of participants, with the “designer” getting hundreds more times reward than the “voter” does. We wonder how we can identify, encourage, and facilitate “player” participants, and see this as a worthwhile future topic of research.

### **3.6.5 The Rate of Satisfaction**

Overall, the subjects who were in FTF teams expressed their satisfaction with that method. Some members in TO teams felt they didn’t have enough communication between members. However, unlike in our following (embodiment) experiment, not many TO team members had strong dissatisfaction with the TO method for concept generation.

### **3.6.6 Test Subjects for TO Method**

We found that using college students as an online community simulation has drawbacks. Our experiments showed that familiarity with the tools is not a guarantee for online

project success. It seems the biggest different between students and real world community members is the enthusiasm. The online communities are usually built up by enthusiastic members. Such enthusiasm is the key to motivate members to communicate and interact more often. We haven't seen such enthusiasms in any of our research in which students are used as subjects. In their books discussing creativity, Kelly & Littman (2005) and Sawyer (2007) emphasized "passion" numerous times. Without it, innovation would not happen, or it will only happen to a lesser extent.

### **3.6.7 Individual vs. Team**

Our experiment shows that letting team members create design concepts individually first did not hinder the subsequent team effort. Although social loafing was identified within our FTF teams at a low level, it didn't seem to hurt the team results. This is particularly true in the context of our experiment, in which we were most interested in the *quality* of the designs. The results seems to be aligned with those of Paulus and Yang (2000). In their experiments they introduced additional sessions of individual work, both before and after group brainstorming sessions, in order to alleviate the effects of social loafing, production blocking, and free riding. They found that with these additional sessions, the team approach was more productive than nominal individual groups. However, our results didn't show that the team efforts were necessarily better than the nominal individual team efforts. I am wondering if this is related to the design challenge that introduced in this experiment. It was a subject that the students were not familiar with, so if all group members are similarly unfamiliar,

group efforts are not necessarily helpful. If the test subject were experts in this field, group efforts might help by, for example, making it less likely that teams overlook important aspects of the design problem. In this regard, if the commonly identified inefficiencies of group brainstorming (social loafing, production blocking, etc.) are not present, then we might expect brainstorming with expert groups to be more productive than that of nominal groups of experts. So far most brainstorming research has used non-expert as experimental subjects. I think it would be a worthy future research effort to investigate brainstorming effectiveness with expert design subjects.

### **3.7 Summary**

Based on the experiment results and discussion above, we conclude that with appropriate communication and organization, the threaded online method is as productive as a face-to-face method for mechanical design concept development. Due to the asynchronous nature, the threaded online method needs a larger group and more enthusiastic participants to fully utilize its advantages.

# Chapter 4

## Open Collaborative Embodiment Design for Mechanical Engineering<sup>23</sup>

### 4.1 Introduction

In reality, the use of Crowdsourcing and open source techniques for product design and development is still in its nascence (see Schonfeld, May 2008). One reason for this might be that it is more difficult to do development work with crowds than it is to have crowds suggest innovative ideas. This seems evident from Cambrian House CEO Michael Sikorsky's response to Schonfeld's article (Schonfeld, May 2008): "*It would have been better to back great teams with horrible ideas because most of the heavy lifting kept falling back on us, or a few select community members. A vicious cycle was created leading all of us to get more and more diffuse... Trying to find people **willing** or **capable** to take on the offspring (our outputs) of the CH model was hard and/or incredibly time consuming.*" This seems to reveal the common obstacles that affects all open source / Crowdsourcing community / industry: what shall we do after we have "this" great idea? Part of our research interest to find the open source / Crowdsourcing design methodology that would help in this part of the

---

<sup>23</sup> This chapter is largely based on an ASME 2009 conference paper (Zheng and Jakiela, 2009a). Large sections of that paper are excerpted and revised for use in this chapter. This use is with the permission of the American Society of Mechanical Engineers.



development process. As such, our focus for this experiment is to investigate what we call the *embodiment design* stage of mechanical design using a threaded online (TO) approach.

The term *embodiment design* came from French (1971). In his book, he splits the design process into four phases: analysis of problem, conceptual design, embodiment of schemes, and detailing. *Embodiment* is therefore the development of a more or less abstract concept into a more concrete proposal. Pahl & Beitz (1996) split the design process into four phases as well: product planning and clarifying the task, conceptual design, embodiment design, and detail design. The input to the *embodiment design* is a design concept and the output is a technical description, often in the form of a scale drawing. Furthermore, Pahl & Beitz indicated that *embodiment design* incorporates both *layout design* (the arrangement of components and their relative motions) and *form design* (the shapes and material of individual components) (Pahl and Beitz, 1996).

Although the motivation for our research comes from an interest in Crowdsourcing and online collaboration done in an open manner, this is probably less important for the embodiment phase than it is for concept development. More and more companies increasingly rely on dispersed research and development teams in order to keep pace with resource availability and the demands of global markets (Boutellier *et al*, 1998). It is plausible that, with restrictions on participation, the threaded online method can be applied to these global research and development teams of the proprietary companies in

a non-open manner. In the experiment described in this chapter, we will compare the efficacy of face-to-face and threaded online teams on a design embodiment task.

## 4.2 Related Work

Much of the discussion of related work found in Chapter 3, specifically section 3.1 concerning group size and performance, sections 3.2 dealing with face-to-face versus computer-mediated collaboration on education and learning, and distributed or collocated team effectiveness related to interaction and management, are also relevant here. Please refer to those earlier sections.

## 4.3 Methods<sup>24</sup>

There are many factors that could affect collaboration. The goal of this experiment is to compare the effectiveness of collaboration methods in mechanical embodiment design, with the two methods being face-to-face versus threaded online. Hence, we want to eliminate other possible factors as much as possible.

---

<sup>24</sup> Washington University Human Research Protection Office (HRPO) study number X08-1075

### 4.3.1 Subjects

30 senior students enrolled in the capstone design course in the Mechanical, Aerospace and Structural Engineering department of the Washington University in St. Louis participated for partial course credit. The subjects have received relatively rigorous and comprehensive academic training in mechanical engineering design. Recalling Sikorsky's self-assessment (Schonfeld, May 2008), the participants are all "**capable.**" However, as students, the participant's "**willingness**" is not the same as shown by real-world online community's members. After all, they participated because part of the course grade was awarded, not because they are interested in the project itself. However, all participants were given the choice of not participating and opting for another assignment. None of the participants chose to do so. Most of the participants have used the threaded online collaboration tool, the *Wedesign* website, which we developed for this open source mechanical design research (Jakiela and Zheng, 2008) in previous courses, so they were familiar with it.

### 4.3.2 Experiment Setup

The subjects are divided into two groups for the experiment, one for face-to-face method, and the other for threaded online method. Each group had 15 students to form several teams to tackle the same engineering embodiment challenge. We were conducting two experiments in sequence at the time. We did the *Conceptual Design* experiment (Zheng and Jakiela, 2009b, and Chapter 3) first. We **randomly** assigned

students to teams with the constraint that no team member had been in the same design team of a previously held design activity in the same class. Those who were in the FTF group in the *Conceptual Design* experiment would be in the threaded online group in *Embodiment Design* experiment. However, the member in each team is rearranged to ensure that no two team members had been in the same team in the previous course work also. The intent was to break the social bonds that the students may have developed during any previous activities (Yang and Jin, 2008). The team size is still kept at 3 people per team, as it was for the concept generation experiment.

The mechanical embodiment design problem, shown below, was given to all students. All teams, FTF or Wedesign, had three weeks to finish this task. A survey was conducted after the experiment to learn students' satisfaction with this experience and obtain any suggestions from the subjects.

### **4.3.3 Embodiment Challenge**

The engineering challenge we assigned in this experiment was derived from a real world problem. Teams were asked to design a sub-assembly for a drywall manufacturing line. As shown in the figure below, production requires that a drywall board be flipped over before being sent to an oven for baking. The physical properties of the drywall board were given. A powered dual-belt conveyor moves the boards in and out of a flipper and can be stopped during the flipping process. Sizes shown in the figures are approximately

to scale relative to the size of the drywall board shown. CAD files of all of the parts of the assembly were provided to all subjects.

The students were asked to design a “flipper”, which is shown as the *blue* part in the figure. This will accept a board coming off the upstream belts into one side of a dual fork as shown. The fork then rotates 180 degrees, allowing the downstream belts to contact the board, pulling it out of the fork, and sending it on to the oven. At the same time, the other side of the dual fork moves into position to accept the next board.

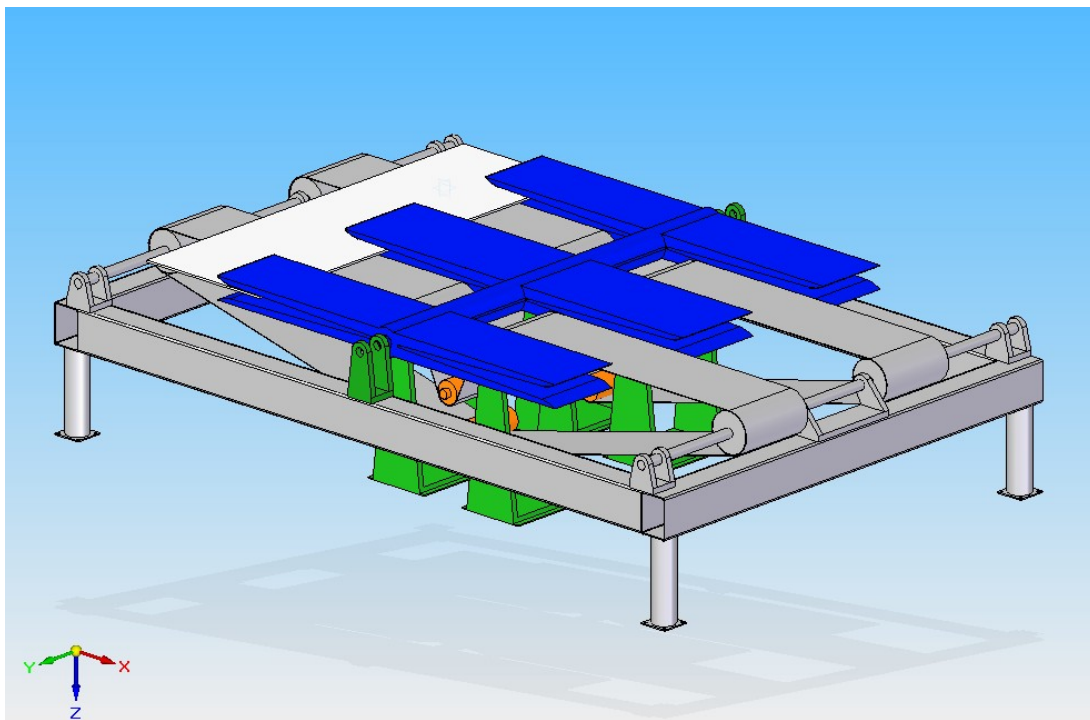

**Figure 4.1:** Dual “Fork” and Conveyor System

The tasks are:

1. Designing the specifics of the dual fork.

2. Design a powertrain that causes the dual fork to rotate. This should include a correctly-sized AC motor with some means of turning the fork axle at the correct speed and stop at the specific position.
3. Design a frame that will rest on the floor and hold the powertrain and attached fork in the correct position with respect to the conveyor.
4. Design a sensor system to allow the conveyor and/or flipper to stop and start. Indicate where and what type of sensor(s)/switch(es) should be used. Specifics of controlling the motor were not required.

The conveyer assembly (shown in gray and orange parts) should not be modified in any way, including their relative positions. However, the green parts and the flipper (blue) can be altered as part of the design embodiment.

Before the experiment started, students were informed that their grade would be affected by their work quality. As will be explained below, expert judges scored the work with respect to several criteria. This scoring did not influence the grade given to the students. As a practical matter, the grade actually earned by the students was most influenced by the degree to which they completed the experiment.

**Tools:** We used a video camera to document all FTF activities. The FTF teams informed the researchers of their meeting times to allow this. The threaded online teams used the PHP-based forum software “WeDesign” developed by Jakiela & Zheng (2008).

These subjects were requested to log on with an alias web name, and not reveal their personal identity to teammates.

**Hypothesis:** The hypothesis of this experiment is that, with all other conditions being equal as much as possible, the WeDesign teams would perform equally well, if not better, than the FTF teams. Performance would be measured by the quality of the design embodiment work produced by each team. Specifically, four characteristics of the work (described below) would be subjectively evaluated by expert assessors. These characteristics would be assessed for four subsystems (dual fork, powertrain, frame, sensing/control) of the overall embodiment problem.

**Independent Variable:** The independent variable is the design method, FTF and threaded online, used for conducting mechanical embodiment design.

**Dependent Variable:** The dependent variable would be the four characteristics that were assessed:

1. **Completeness.** Has all work been completed on the subsystem?
2. **Consistency.** Will all parts of the subsystem work together?
3. **Fabricability.** Could the subsystem be made with reasonable effort?
4. **Engineering Excellence.** Does the design show generally good engineering work? Have the designers recognized/identified the key issues (e.g. weight, energy/power, material selection, environmental issues) and performed the appropriate analyses?

## 4.4 Results

There were two groups, threaded-online (TO) and face-to-face (FTF). Each had five teams participating in the experiment. In the end, each group (mode) had one team that failed to produce any meaningful results at all, yielding 8 “design embodiments,” each with four subsystems. The non-producing FTF team didn’t meet. The non-producing TO team did have two members log on, but they failed to produce any significant results.

As discussed in Chapter 3, the CAT technique was applied here in order to assess the design merit of the results. We used the initial three judges that were used in the previous concept generation experiment. Interestingly, all three judges tended to agree with each other on these design criteria. The inter-judge reliability of each design criterion is shown below (Table 4.1). The reliability for Completeness, for example, arises from comparisons among the judges’ scores for the 32 (eight completed design embodiments each with four subsystems) completeness evaluations. Reliability for the other three criteria are done similarly. The overall reliability arises from comparisons among the judges’ total 128 (again, 8 design embodiments, each with four subsystems, with each subsystem evaluated with respect to four criteria) evaluations. Although the reliability on “Consistency” is slightly lower than 0.7, since the overall reliability is greater than 0.7, we think the assessment results are acceptable.



Table 4.1: Inter-judge Reliability

Number of Judges	Completeness	Consistency	Fabricability	Engineering excellence	Overall
Three	0.730	0.682	0.708	0.798	0.732

Table 4.2: Mean and Variance

Method	subsystem	Mean / s.d	Completeness	Consistency	Fabricability	Engineering Excellence
Threaded Online	Dual fork	Mean	2.17	2.42	2.25	2.33
		s.d	1.23	1.10	1.50	1.63
	Power Train	Mean	2.08	2.17	2.08	2.33
		s.d	1.26	1.35	1.26	1.54
	Frame	Mean	2.42	2.50	3.00	2.17
		s.d	0.74	1.04	1.05	1.17
	Sensing / Control	Mean	2.00	2.08	2.17	2.08
		s.d	1.19	1.32	1.35	1.26
Face to Face	Dual fork	Mean	2.17	2.17	2.33	2.00
		s.d	0.79	0.43	0.72	0.72
	Power Train	Mean	2.83	2.67	2.58	2.58
		s.d	0.84	0.86	1.10	1.13
	Frame	Mean	2.33	2.50	2.50	2.00
		s.d	0.61	0.64	0.79	0.98
	Sensing / Control	Mean	1.67	1.83	1.83	1.67
		s.d	1.12	1.04	1.26	1.33

The experiment results in the form of mean and variance of the four criteria for the four subsystems, by the two team methods are shown in Table 4.2. All criteria were scored by the judges on a 1 . . . 5 scale. A one-way analysis of variance (ANOVA) test was conducted to see if the outcome of the two team methods is equal, shown in Table 4.3.

Table 4.3: Results of ANOVA

Contrast	Mean Square	F value	P value
TO vs. FTF (all)	0.170	0.01	0.9251
TO vs. FTF (Mean dual fork)	0.500	0.13	0.8720
TO vs. FTF (Mean power train)	1.125	0.06	0.8091
TO vs. FTF (Mean frame)	8.000	0.42	0.5210
TO vs. FTF (Mean sensing/control)	3.556	0.19	0.6680

## 4.5 Implications and Discussion

As shown in the ANOVA results, the differences between the mean of the threaded online method and that of the face-to-face method are not significant, either considering the whole design embodiment or considering the subsystems. This means the results from the two methods are statistically equal. However, the conclusion that the threaded online method is as good as the face to face method in terms of productivity is not easy to make, particularly if we consider the following factors:

### 4.5.1 The Size of the Task

Although the challenge we employed in this experiment was not simple and the solution was not obvious, it could be done by an individual. It would be possible for a single student to finish the embodiment task, working alone, in the time given. We were hoping to see teammates divide the work, allowing each member to have more time to tackle sub-problems, and collectively do a better job than a single person could. This did

not happen. A single person in one TO team finished the task virtually single-handedly, and his overall score was better than any other team in the entire experiment. If the task truly is bigger than a single person could do in the time given, would a TO team still perform as well as an FTF team? We do not know.

#### **4.5.2 The Rate of Participation**

In this experiment, both groups had participation problems. The FTF group had one team that did not meet. No TO team had full participation from all team members. One team in this group had only one member participate, doing only the work expected from one person. Two other teams had only one member make any significant contribution, while the other members did very little. Only one team had two members divided the load about equally and collaboratively finish the task to a certain degree. One team had two members participate, but they failed to create any meaningful results. The implications of all of this are twofold. On the one hand, this implies that the TO method tends to have less cohesiveness among team members. Although the students know each other through other courses, when real names were not used in communication, the limited social bond and accountability were evident. It seemed as though TO participants would abandon the effort, rather than be the first to post work asynchronously. We note with some anxiety that, like real world “open” collaboration practice, quitting was allowed in our experiment. The number of TO participants that *did* quit was distressing. On the other hand, the four fully participating FTF teams didn’t do better work than the short-handed TO teams. This suggests that (possibly

agreeing with Latané, Williams and Harkins (1979)) so-called *social loafing* was present among our FTF teams.

### 4.5.3 The Rate of Satisfaction

The difference in participant satisfaction between these two methods is very distinct. 6 of the 15 FTF participants submitted surveys. Among these, all believed they did a good job and were quite satisfied with the method and their results. When asked whether they would prefer a FTF method to a TO method, all agreed, with some suggesting adding other means of communication such as email, phone and text messaging. 8 of the 15 TO participants submitted surveys. Among these, all felt they didn't do a good job and were quite dissatisfied with the method and their results. When asked whether they would prefer a TO method, 7 said no.

One aspect that we also saw in the related (concept generation) experiment (Zheng and Jakiela, 2009b) that perhaps warrants further investigation is the phenomenon of quitting. Online team members tended to quit when frustrated. We were surprised at how many readily forfeited course credit by quitting. One student offered a possible explanation in his survey: "Almost nobody in the class paid attention to the project because of its laughably large scale and being placed in the middle of a semester in which we have many more important things to do." In reality, we gave students three weeks of time, and the majority of FTF teams took about one hour to finish the task. The idea that an asynchronous means of communication was somehow more

convenient than having a face-to-face meeting (e.g. (Boutellier *et al*, 1998)) was not supported by the behavior of our TO teams. The majority of complaints, though, focused on accountability and lack of communication. We wonder if this contributed to the “inertia loafing” we observed (also in Zheng and Jakiela, 2009b). TO participants were reluctant to make collaborative contributions without the immediate recognition and validation that would be provided by an FTF setting. They were unmotivated to say anything if they were not sure anyone was listening. We feel that further research on this topic is worthwhile.

#### **4.5.4 The Application of CAT**

In this experiment and the previous one, we applied the Consensual Assessment Technique to assess the subjective design criteria. However, the inter-judge reliability varies. In the previous chapter, the reliability of the subjective criterion “Innovative” is high, while the reliability of the more or less objective criteria “Functional” and “Realistic” are low. In discussing types of factors for which the CAT method is appropriate (following on discussions by Amabile (1982)), Fodor and Carver (2000) suggest that only certain factors have utility for engineering problems. Although it is unclear if Functionality and Realism from our earlier experiment are similar to, or among, the factors that would be useful, like them our results show that some criteria do not seem to easily generate high reliability among expert assessments. Understanding which factors are appropriate for analysis of engineering design would be useful future research.

## 4.6 Summary

Based on the experiment results and discussions above, we conclude that with appropriate task size and adequate participation, the threaded online method is as productive as a face-to-face method for mechanical design embodiment problems. However, additional measures, such as participants knowing one another, and project management mechanisms are needed. Here are things that I think is necessary to be adjusted for a future study:

1. It is very important that the community be more cohesive to ensure project success. One way to encourage cohesiveness is that members need to know each other beyond the internet alias names. Additionally, a reliable and productive online community needs to be mature first before they can take on challenges.
2. People need some type of continuing motivation in order to keep going on online projects. They must get some kind of reward for their efforts, either monetary, status, or the pure satisfaction of achieving something.
3. Related to this, this means that the project needs to be subdivided into small enough pieces so that each player can unambiguously complete an identifiable task. The entire project, on the other hand, should be much larger than any one player could complete on their own, thereby requiring collaboration.
4. The community has to be big enough to allow attrition of members without jeopardizing the entire project. Clearly, three is not a large enough number.

# Chapter 5

## Open Collaborative Prototyping and Manufacturing for Mechanical Engineering<sup>25</sup>

### 5.1 Introduction

Ulrich & Eppinger (2003) divide a Generic Development Process into six phases: Planning, Concept development, System-level design, Detail design, Testing and refinement, and Production ramp-up. The first four phases closely resemble the four mechanical design phases specified by French (1971) and Pahl & Beitz (1996). French's definition of the design process is analysis of problem, conceptual design, embodiment of schemes, and detailing. Pahl & Beitz's definition is product planning and clarifying the task, conceptual design, embodiment design, and detail design.

One shared characteristic of the four design phases suggested by French and Pahl and Beitz is that they all can be completed by making drawings, doing calculations, making CAD models, etc. As described and tested in our previous research (Jakiela and Zheng, 2008; Zheng and Jakiela, 2009a, 2009b), along with some practices in the real business

---

<sup>25</sup> This chapter is largely based on a working paper that accompanied a presentation made at the International Open and User Innovation Workshop 2009 (Zheng and Jakiela, 2009c).

world<sup>26</sup>, these four design phases can be carried out by an *Open Design* method approach similar to the now well known *Open Source* software design practice. The fifth and sixth phases suggested by Ulrich & Eppinger (2003), however, would involve tangible artifacts that cannot be shared over computer networks. As put by *Advanced Civilization*<sup>27</sup> website:

There are certain barriers to overcome for open design when compared to software development where there are mature and widely used tools available, and the duplication and distribution of code cost next to nothing. Creating, testing and modifying physical designs are not quite as straightforward because of the effort and time required to create the physical artifact.

Furthermore, unlike electronic copying, physical duplicates of artifact are not exactly the same. This implies that manufacturing quality control, a process that is not necessary in software product development, is involved. What we are interested in is how the prototyping and/or manufacturing phase would be carried out in open design projects.

There are two different kinds of open design projects. Similar to what West and O'Mahony (2005) described in their research on open source software projects, open design projects can be divided into a *sponsored (also called spinout)* or a *community founded* project<sup>28</sup>. Although community founded open design projects have yet to set an example as influential as Linux was for the open source software domain, there are some success stories that shed light on this category. A custom T-shirt design /

---

<sup>26</sup> Threadless: [www.threadless.com](http://www.threadless.com); Cambrian House: [www.Cambrianhouse.com](http://www.Cambrianhouse.com), Innocentive, [www.innocentive.com](http://www.innocentive.com), etc.

<sup>27</sup> [http://www.adciv.org/Open\\_collaborative\\_design](http://www.adciv.org/Open_collaborative_design). 'Open source' applied to the physical world.

<sup>28</sup> A *community founded* project refers to a project that is initiated within an online community that is not affiliated with any established company; while a *sponsored* project refers to a project that was initiated by an established company that “opened up” part or all of its then-proprietary product information in the hope of it being improved or radically redesigned by the external communities.



manufacturing company called *Threadless*<sup>1</sup>, runs its business by utilizing member-generated T-shirt designs and sells the end product to online customers. However, its prototyping process is not open. After members submit their T-shirt design to the company, the company's in-house experts artistically re-render members' designs to make demo T-shirts for public voting. Another example would be *Mophie*, and their hit product named *Bevy*, described earlier in Chapter 1. The company designed it at 2007's MacWorld conference in 72 hours with input from 30,000 customers, using software that was a precursor to *Kluster*<sup>29</sup>. Encouraged by the success of *Bevy*, Mophie founder Ben Kauffman sold the company, and started to pursue community founded projects by founding an internet *Crowdsourcing* (Howe, 2006) company called *Kluster*. At the TED<sup>30</sup> 2008 conference, *Kluster* launched another 72 hour project<sup>31</sup> which sought to design one "thing" that would promote global awareness. The result was a board game, called "*over there*", that has rules reflecting current world issues. The prototyping of the game was supported by a publicly accessible machine shop called *Techshop*<sup>32</sup>, that provides manufacturing tools and training on how to use them.

Sponsored open design project examples, however, are hard to find. This may be partly due to the fact that the open design method is a fairly new design methodology. Christensen (1997) stated that established market leaders are almost always too late in adopting these disruptive (new) technologies. He further specifies several reasons for this problem, ranging from cultural and psychological factors (arrogance, bureaucracy,

---

<sup>29</sup> [www.kluster.com](http://www.kluster.com)

<sup>30</sup> [www.TED.com](http://www.TED.com). TED stands for Technology, Entertainment, and Design.

<sup>31</sup> <http://beta.kluster.com/home/ted>

<sup>32</sup> <http://techshop.ws/index.html>

short-term thinking, etc.) to economic aspects (high fixed costs forcing companies to focus on large markets only, reluctance to turn past investments into sunk costs, etc.) (Franke and Schreier, 2002). Thomke and von Hippel (2002) reported that a company named Bush Boake Allen (BBA) had attempted to utilize a customer-as-innovator approach.

The company developed an Internet-based tool containing a large data-base of flavor profiles. A customer can select and manipulate that information on a computer screen and send his new design directly to an automated machine (perhaps located at the customer site) that will manufacture a sample within minutes (Thomke and von Hippel, 2002).

After tasting the sample, the customer can make any adjustment as they see fit<sup>33</sup>.

Based on the research we have done, it seems to us that the idea of *open prototyping and manufacturing*, especially collaborative open prototyping and manufacturing, hasn't been explored much. However, as part of the development process, prototyping is an important step and shouldn't be left out of the overall open design process, because it either proves or disproves the efficacy of the design. As Ulrich and Eppinger (2003) state, "prototypes are often used to answer two types of questions: 'Will it work?' and 'How well does it meet the customer needs?' They are also used to ensure that components and subsystems of the product work together as expected" (Ulrich and Eppinger, 2003). In software engineering, the phase similar to prototyping is called "compiling". In this phase, the finished source code is translated into executable code

---

<sup>33</sup> BBA was acquired by IFF (International Flavor and Fragrance) in 2001. From the current IFF website, it seems to us that they are instead putting the "flavor" machines at customer centers (IFF facilities) in key regional headquarters around the world. It is unclear if customers are still doing prototyping on their own.

that can be run on computer hardware. In software, the compiling phase is conducted by the “compiler”, a translation tool that can translate source code into binary machine code. In a physical domain, however, translating the detailed design into a tangible artifact can be done in a variety of ways, from a skilled craftsman using hand tools to computer-numerical-control (CNC) machining. CAD/CAM systems integrated with CNC tools are similar to software compilers in that an input source code is translated into commands that drive an automated machine tool to make a part. Such systems, however, are costly and are not as readily available to the general public as software compilers are. We will discuss this in detail in the following section.

We setup an experiment to explore *open prototyping and manufacturing*. Some questions we have in mind when designing the experiment are listed below. The scope of the experiment is too small to answer these questions in a definitive manner. However, we believe the results, if not answering the questions, at least point to interesting research directions. The questions are:

1. *Would **open** prototyping be necessary for open design projects, in either a community supported mode or a sponsored mode?*
2. *More specifically, because prototypes validate design concepts, would a process of building prototypes alter the preferences of the members of the community? Would evidence provided by a working prototype cause the overall community to choose a different design than they would have without seeing a prototype?*

3. *Would open manufacturing be possible? Would people trust other people's manufactured parts?*

There are many regular homeowners who have their own machine shop, and *Do-it-yourselfer* is a relatively large community. We are wondering if we can turn this distributed manufacturing force into a real productive community.

## 5.2 Related work

### 5.2.1 Virtual Prototyping

A Virtual Prototype is a major interim step towards the final product. Based on the design information, like geometry and topology, simulation results, and FEM or kinematic calculations, combined with material choices, tolerances and other information, it will be possible to generate a computer-based prototype ready for realistic presentations as well as interaction with the product even in an early stage of the development (Rix, Hass and Teixeira, 1995).

With the current capabilities of computer 3D rendering, computer-aided design (CAD), finite element method (FEM), and computational fluid dynamics (CFD) technology, virtual prototyping has reduced the number of physical prototypes needed. “The accuracy of virtual prototyping for fit and interference checking has increased to such a high level that the Boeing 777, as the first commercial aircraft designed 100 per cent

digitally with solid models, did not require any physical prototypes to obtain accurate fit” (Zorriassatine *et al*, 2003). The virtual prototyping technique has been explored for use in various industries such as shipbuilding (Bandula and Bandula, 2002) and train carriage design (Seron, *et al*, 2004). However, virtual prototyping still cannot replace all physical prototyping. The first actual Boeing 777 aircraft, along with other test planes, serve as physical prototypes to be used to test the integration of all subsystems and to pass FAA certification.

Current virtual prototyping systems are largely proprietary software that is not easily accessible by everyone. However, the open source software industry is fueling the open design community with free and open source CAD and FEM software that is needed for the open design projects (Riverside, 2007). All the technologies exist, as put by Advanced Civilization<sup>34</sup>, “they just need to be put together in the right way and refined.”

## 5.2.2 Rapid Prototyping

Rapid Prototyping, also known as “StereoLithography”, or 3D printing, is a technology pioneered, among others, by a company called 3D Systems (Valencia, CA) (Jacobs, 1992). The software divides an object into a number of very fine layers, and a prototyping machine can print each layer with liquid photopolymer and cure it with heat. Layer by layer, a final solid object would be created from a 3D CAD drawing. Other means of manufacturing which use the same layer by layer approach, but with

---

<sup>34</sup> [http://www.adciv.org/Open\\_collaborative\\_design](http://www.adciv.org/Open_collaborative_design). 'Open source' applied to the physical world.

different material, paper for example, are also available (Bailey, 1995). Although virtual prototyping greatly enhanced the visualization of the design, rapid prototyping provided geometric verification capability for the design. Some can even perform dynamic tests on the prototype within the physical limits of the solid materials. Obviously, however, verification of other characteristics such as strength, operational temperature limits, fatigue, corrosion resistance, etc., will have to wait for the results of tests on a fully functional prototype. However, as Jacobs (1992) argues, designers and engineers will be able to hold in their hands, at a much earlier date, a part which has been geometrically verified.

At the current technology level, the rapid prototyping machines are still too expensive for regular consumers. Compared to CAD software packages, the 3D printer is more financially prohibitive. However, effort and progress has been made to make such machines cheaper and more accessible to the general public. With the current technology improvements, we can foresee such machines will be as widely available in the near future as a laser printer is available to the regular consumers today. One example of such effort is a rapid prototyping project called RepRap<sup>35</sup>. The name is short for self-replicating rapid prototyper and the project was started at the University of Bath by Dr. Adrian Bowyer, a Senior Lecturer in mechanical engineering. The machine is a 3D printer that makes real, robust, mechanical parts, and can literally make a copy of itself. The material costs of this machine are about 500 euro, which is quite acceptable for regular consumers. The quality of the parts it makes is inferior to those made by

---

<sup>35</sup> <http://www.reprap.org/bin/view/Main/WebHome>

commercial 3D printers, however. The RepRap team is giving away the design of this machine under the GNU General Public License, so small communities in the developing world as well as individuals in the developed world could access the rapid prototyping capabilities.

### **5.2.3 Toolkit for User Innovation (TUI)**

There are much literature concerning turning customers into innovators. Thomke and von Hippel (2002) presented a new approach to developing custom products by using a *Toolkit for user innovation* (von Hippel and Katz, 2002; Franke and Piller, 2004). According to von Hippel and Katz (2002),

Toolkits for user innovation are coordinated sets of ‘user-friendly’ design tools that enable users to develop new product innovations for themselves. The toolkits are not general purpose. Rather, they are specific to the design challenges of a specific field or sub field... Within their fields of use, they give users real freedom to innovate, allowing them to develop producible custom products via iterative trial-and-error. That is, users can create a preliminary design, simulate or prototype it, evaluate its functioning in their own use environment, and then iteratively improve it until satisfied.

In their articles, von Hippel (2001) provided examples of the TUI method applied to custom integrated circuits, custom telephony services, custom hairstyles, and custom foods. Franke and Piller (2004) demonstrate a case of customers using TUI to design custom watches. In all these cases, toolkits allow customers to create their own product, which in turn is produced by the manufacturer (Franke and Piller, 2004).

This method is very close to the sponsored open mode we discussed above, with a focus on Business to Customer, or Business to Business collaboration, while not much

focused on Customer to Customer (C2C) collaboration. Nevertheless, we think this method is a good starting point for our open prototyping / manufacturing approach. Our experiment would be based on TUI principles, while altered to facilitate C2C collaboration in the context of hardware prototyping.

## 5.3 Methods<sup>36</sup>

Piller and Walcher's (2006) work on toolkits for idea competition served as the inspiration of our experiment. They argued that "Idea competitions build on the nature of competition as a means to encourage users to participate at an open innovation process, to inspire their creativity, and to increase the quality of the submissions." To go further on this approach, we wonder if collaboration on prototyping and manufacturing in a competition environment would inspire creativity and productivity as well.

Intuitively, collaboration and competition do not usually go hand in hand. Competitors would always seek an edge over others. Keeping trade secrets from others is a common practice under such a mentality. However, if success is not measured by the rank within the competition (i.e. against each other), but against an absolute standard, then by collaboration, those who are more "capable" would not be punished by "opening up" their activities. This does not imply that every "capable" person would choose to do so. However, even when just one such person chooses to "open up", the performance of the entire community could increase. This is actually the main rationale

---

<sup>36</sup> Washington University Human Research Protection Office (HRPO) study number X08-0321



behind all open source / open design approaches, and our experiment would serve as a test of the validity of this rationale.

### **5.3.1 Subjects**

50 undergraduate freshmen and sophomore students enrolled in an entry level mechanical engineering design course of the Mechanical, Aerospace, and Structural Engineering department of the Washington University in St. Louis participated in our experiment. This course teaches the students some basic physics laws relevant to the mechanical engineering discipline as well as the skills to use various shop tools. A main activity of the course is a design contest in which individual students design and build a machine that performs in a contest.

### **5.3.2 Experiment Setup**

The design course consists of a design contest in the final phase of the class, which provides the students a chance to practice what they learned in the class as well as to raise their interests in mechanical engineering design. There is a workshop dedicated for this class which contains hand tools and power tools such as lathes, band saws, drill presses and grinders, etc. Although the students have the option to build their device with their own tools and methods, away from this class workshop, most of them choose to do the prototyping and manufacturing task in the class workshop. The contest was divided into three phases:

- In the first phase, the students were assigned the contest challenge and given a package of material that they can use to build their device, both of which are detailed below. They were told to submit one individually-done concept sketch of their best design idea. Past experience with the course has shown that a large group of students will generate only a handful of distinct designs. Put another way, usually all concepts produced can be classified into a relatively small number of categories. The instructors of the class review all the design sketches and put them into these categories. The instructor will then make a sketch of the exemplary device that would best represent each category and present it to the entire class. A survey was conducted before the students saw the contest description.
- At the beginning of the second phase, the students were told which category their concept was in, and were given the opportunity to change categories. The students were allowed to build more than one device that could belong to different categories for a “dry run” of the contest, but they had to choose a single machine for a single attempt at this dry run. The material they used should not exceed the material package given. The students were also allowed to form groups of any size within each category and collaborate on their detail design and prototyping effort. However, each student had to have her own individual device to compete. Any amount of collaboration was allowed, ranging from no collaboration at all to manufacturing identical machines within a group. The instructors also allowed monitoring, discussion and criticizing between

groups. The time span for this phase, from the posting of concept categories to the dry run, was one week.

- At the beginning of the third phase, having just completed a dry run, students should have a clear idea of whether their device would work or not and how well it would perform. At this point, the students were again allowed to change design category, requiring the fabrication of a new machine. This was allowed so long as their final machine was constructable from the specified kit. One week after the dry run, it was contest time. The final contest was conducted exactly the same way as the dry run, except the contest performance would contribute more to the course grade. Another survey was conducted after the contest was completed.

The students were informed that their partial course grade depend on their performance on these three phases. The first phase score would depend on their overall drawing skills and design quality. The second and the third phase scores would depend on their devices' performance. The students were told (verbally) that their device performance would be judged against a fixed standard, not their ranking in the dry run or the contest. However, the scale of the standard was not explicitly revealed.

During the whole process, the student activities were recorded with text and videotape by the researchers and their assistants.

### 5.3.3 Experiment Challenge

The following design challenge was assigned to the students. A 1-foot cube starting volume is aligned with the edge of a lab bench. Design a machine/structure that extends a regulation baseball as far away from the edge of the table (i.e. horizontally) as possible. Call this distance the length "L". Also, try to keep the extended ball as close to the lab bench height as possible. Call its deviation from the bench height "D".

Performance "P" will be in units of length, according to the following equation:  $P = L - D$ . In plan (top view) the machine must stay in a "lane" 12" wide extending from the starting volume. Two screws will be provided to fasten the machine to the benchtop (if desired). The machine can only react against the table and the screws. D will be defined by the lowest point of the ball.

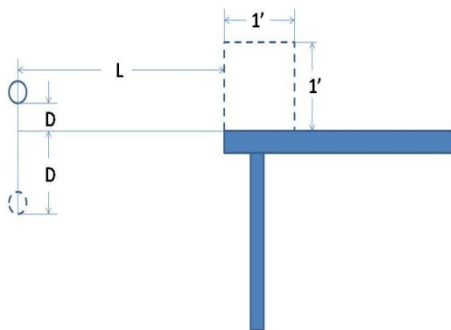

Figure 5.1 Challenge Side View

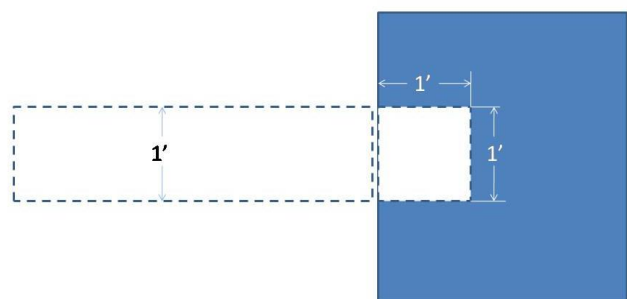

Figure 5.2 Top View

**Tools and Materials:** The material kit we provided to the students is listed below:

Table 5.1 Kit Materials (Supplied in Class and Available Externally)

2 Mouse traps	100 drinking straws
1 audio cassette	Rubber bands (only those supplied in class)
1' X 2' sheet metal	Nuts, bolts, washers (only as fasteners)
2' of 3/16" rod	2' of 1/8" rod
6" of large dia. Wooden dowel	3' of small dia. Wooden dowel
2' X 2' masonite board	2' X 4' foamcore
2 CD-R discs	Bicycle inner tube (20" dia.)
3 balloons	Assorted string
Cereal box cardboard	2 1 liter bottles, screw caps, enough sand (used as weight only) to fill one bottle
Balsa wood TBA	Glue (must be used as <i>glue</i> )

Tools include hand tools such as files, clamps, hacksaw, screwdrivers, drill and taps, etc.

Power tools include lathe, band saw, drill press and bench-top grinder, etc.

We clarify that we did **not** utilize the forum-based tool WeDesign that was used for the three experiments described earlier in this experiment. This was due to the fact that the students were collocated requiring them to work side by side in the workshop. Artificially dividing them up and forcing them to present their work online, although theoretically possible, would be impractical to implement in this class environment. Based on what we found from these earlier experiments (Zheng and Jakiela, 2009a, 2009b), we could predict that the face-to-face collaboration on prototyping would be very different from an online approach. However, we would like to assume that an online prototyping collaboration (with the participants not collocated) would work as

well as the face-to-face collaborative prototyping that is investigated here. Confirming this remains as an interesting future research effort.

## 5.4 Results

### 5.4.1 Concept Category

Among 50 registered students, 46 submitted concept sketches. A total of **three** concept categories were identified. We named them “lazy tong”, “unwrap” and “telescope”. The names are pretty much self-explanatory as shown by the samples in figure 5.3.

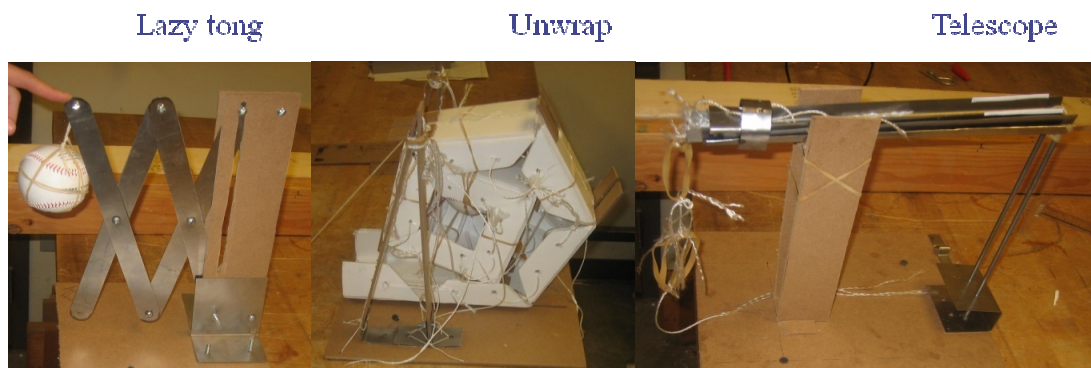

Figure 5.3 Design Categories

### 5.4.2 Dry Run & Contest Scores

Among 50 registered students, 46 operated machines in the dry run. 46 also operated machines in the final contest, except they were not necessarily the same students. Table

5.2 shows the number in each category proceeding from Concept to Dry Run to Contest. Table 5.3 provides detail on how these changes occurred, e.g. from concept to dry run, 9 participants changed from unwrap to lazy tong. Table 5.4 shows the score statistics for the dry run and contest for each of the categories.

Table 5.2: Design Changed

	Lazy Tong (L)	Unwrap (U)	Telescope (T)
Concept	12	24	10
Dry run	26	18	2
Contest	28	16	2

Table 5.3: Migration Trend

	L→U	L→T	U→L	U→T	T→L	T→U	Total
Concept > Dry run	1	0	9	1	6	3	20
Dry run > Contest	1	0	3	0	0	0	4

Table 5.4: Competition Score:

		Lazy Tong	Unwrap	Telescope
Dry Run	Average	8.54	10.66	7.13
	Standard Deviation	11.35	9.11	2.65
	Highest Score	21.5	27.25	9
	Lowest Score	-27.5	0	5.25
Contest	Average	19.95	18.11	8.5
	Standard Deviation	6.08	10.29	4.95
	Highest Score	28.5	36.75	12
	Lowest Score	3	4	5

## 5.5 Discussion and Implications

There are several interesting facts on which we would like to elaborate. First is the number of participants changing categories between each phase. More subjects changed categories from concept to dry run (20 total), than did from dry run to contest (4 total). From dry run to contest, the students may have already seen each other's work result, but few chose to abandon their chosen design even if theirs seemed inferior to the others. This somewhat deviates from what we learned from a "before" survey. We asked "if you saw someone else's design (at any stage of the development), and thought it was better than yours, would you abandon your design and implement theirs? Assume there is no penalty for doing so." 24 said they would abandon, and only 20 said they stay with their design. The implication of this fact is twofold. One is that prototyping **seems** to help **little** in design decision making in an open design practice. Although evidently people do change their mind during concept development, which seems intuitive, people seem to resist change once prototypes are made. This may be partly due to the fact that personal effort was invested during the prototyping process. We wonder if this might be culturally related. The test subjects all came from a culture in which individuality and personal experience are more important than the rank in a competition. Had the subjects come from another culture, the results might be different. The other implication is more subtle and tends to agree with what we found in our previous research (Jakiela and Zheng, 2008). There, we found that people tend to make design choices by instinct (or personal feeling) rather than by formal analysis, even though they were taught to do so. Usually a designer would conduct user needs research



(not necessary in a user as designer case) and factor in each need's significance before making any design decisions. Clearly here and in the situation described in (Jakiela and Zheng, 2008), the test subjects acted more like regular users rather than trained designers. This suggests that when conducting open design projects, the voting process for concept selection should not be conducted before thorough discussion. This would require that the participants explore options more before they vote on their instincts.

The second fact we noticed is that more students chose the *lazy tongue (LT)* design for the dry run (e.g. 26 versus 18) and contest (28 versus 16) rather than the *unwrap* design. Theoretically, the *unwrap (UW)* design has more potential to achieve higher scores than the *LT*. First, the *LT* structure, in its compressed state, will use much valuable space within the 1' cube, requiring that it be actuated from the back of the device. This causes the first section of the structure to not extend out past the edge of the table and hence not contribute to the score. Second, the *LT* structure, as typically made, has identical member shapes for each section. This makes the first section the weakest link in the whole structure (as shown in failure picture below, figure 5.4). Additionally, *LT* links become more unstable when stretched out more. The *UW* design, on the other hand, can easily be deployed from the front edge of the table so every section counts. Each section can easily have a different cross section design to sustain different loads. By carefully adding more sections using different materials and shapes, the *UW* approach is predicted to win the contest. The results support our prediction. Then the question is why wouldn't more students select this design approach, especially after seeing

machines perform in tests and in the dry run<sup>37</sup>? A closer analysis of the data revealed a possible explanation.

On the dry run data, we can see that the *UW* is a clear winner. It has the highest score, highest average score and lower standard deviation compared to the *LT* design. However, taking a closer look at the data we find something interesting. The lowest score of the *LT* design is a very low negative score, which came from a failure that is shown in figure 5.4.

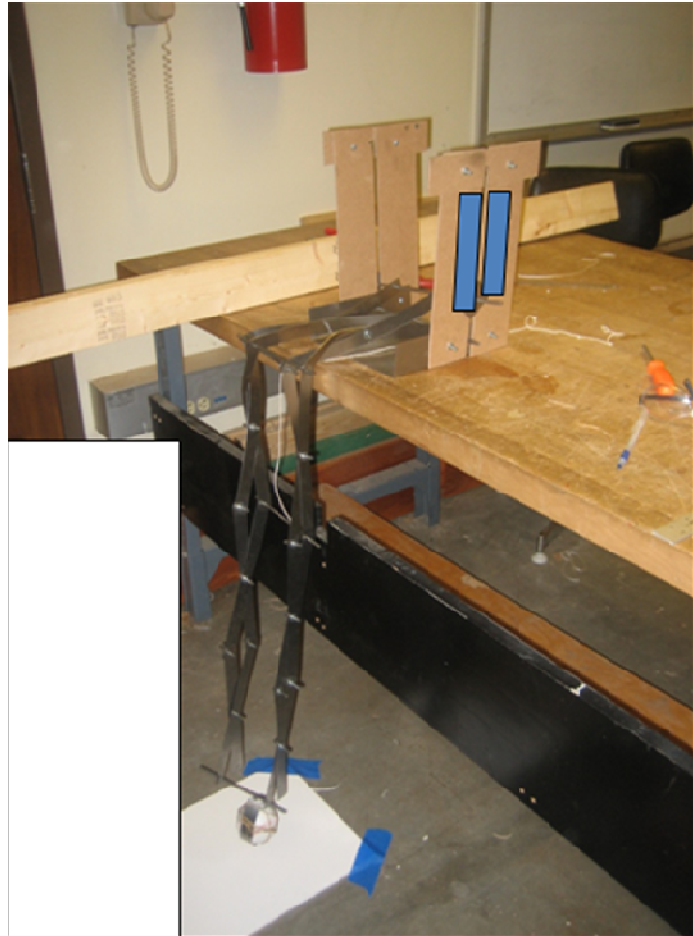

Figure 5.4 Failure of the Lazy Tongue Design

The failure of the first section of the *LT* is the cause. If we remove this score from the *LT* set of scores, along with another relative low negative score, -8.0 to be specific, the average score of the *LT* design was actually on par with the *UW* design (10.73 vs. 10.66

---

<sup>37</sup> We did not explicitly report the results of the dry run to the students. In the open environment of the shared shop, however, students communicate freely and certainly could compare scores. Additionally, students could observe the test runs of others (separate from the dry run and contest).

respectively), while the standard deviation was actually lower (8.17 vs. 9.11 respectively). After we re-exam both designs, a subtle difference might have made the students more inclined to choose the *LT* design.

The *LT* design only needs a single energy source to operate, due to its repeated-sections design. So this design can have better deployment reliability than the *UW* design, which has to have isolated energy sources on each section to operate, and they have to be deployed in sequence. By trail-and-error, the students soon figured out good ways to implement the *LT* design, and during the contest, the *LT* design achieved a better average score, with much less standard deviation, than the *UW* design. However, the highest score of the *LT* was still less than the *UW*, most likely due to the design limitations discussed above. We note that the best lazy tong in the *contest* had a higher score than the best unwrap in the *dry run*.

We wonder if these results suggest that experts (instructors in this case) are more interested in the best solution for the challenge, while the users (students) are more interested in the best solution for their needs (get a decent, if not the best score from the competition). This result is very consistent with Toubia and Flores's (2006) findings. They found that “experts are more sensitive and responsive to ‘solution information’ while consumers are more sensitive and responsive to ‘need information’.” This suggests that open concept selection, and possibly open design in general, is more accurate in capturing the real customer needs than is closed concept selections done by in-house experts. For this practical reason, if we revisit the first implication we note

above, we can see that it is not that open prototyping did little to influence design decision making, it just happened to agree with the open concept selection (i.e. done by users) results.

Another implication we can draw from this fact is that the customer needs may vary, and that there may be more than one **best solution** for the customer. In reality, some customers / users demand the **best** product and are willing to accept compromises, such as multiple actuators that must operate in sequence for an unwrap design. Others demand **good** product with less compromises, such as a lazy tong that requires only one actuator. Good business practice would strive to satisfy them all.

The third fact we observed is that, although encouraged, large scale collaboration between students didn't happen. Ideally, if students picked the best design and collaboratively manufactured parts and assembled identical machines, everybody would share similar high performance scores. In reality, this was not the case. In the "before" survey, we ask whether students are willing to share parts for their design, or even let others make identical machines for them. Among 44 surveys returned, 26 say yes for sharing parts, 18 say no. Only 5 said they would feel comfortable with an identical machine made for them; while 39 said they would not. In the 45 "after" surveys we collected, students revealed that 33 of them did the whole project alone, except for the concept sharing declared by the instructor. 12 did some amount of collaboration. This is in sharp contrast to the "before" survey results. However, the majority of the students were satisfied with this experience (40 yes vs. 4 nay), and felt it was fair (34 vs. 3) and

the work load was the same among categories (31 vs. 7). However, about half of the people felt that they worked more than they would have if a concept-sharing open environment had not been imposed. Even given this, very few objected to participating in the open approach to the contest.

Close collaboration on prototyping was very limited. We witnessed one group, however, that was worth noting. They shared an identical design, parts, and final assembly, as shown below.

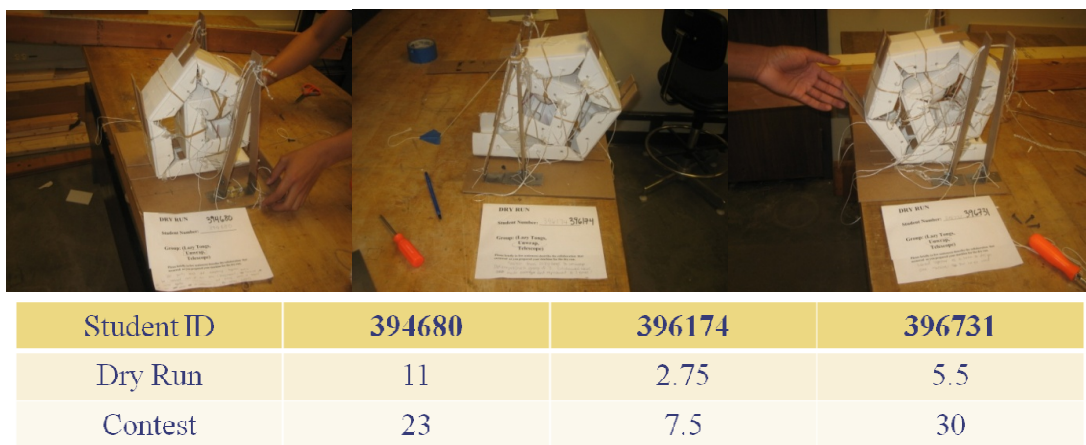

Figure 5.5: Open Manufacturing Sample

Apparently, the skills of those students using tools are not uniform, and the detail design of their device had a lot of flaws. These three machines, although identical in design, parts, and assembly, perform quite differently during dry run and contest. This suggests that unless there is some form of quality control, open manufacturing with individuals is less likely to be successful. However, the tools and material used in this experiment are somewhat primitive. If skilled individuals with sophisticated

manufacturing means and established manufacturers participate in the open projects, using suitable quality control mechanisms, open manufacturing may be quite possible. Further research in this direction is worthwhile.

## 5.6 Summary

Based on the discussion and the results of this experiment, we think we can answer the three questions that we raised at the beginning of this chapter with some confidence.

1. *Would **open** prototyping be necessary for open design projects, in either a community supported mode or a sponsored mode? Would open prototyping actually change the final outcome of an open design project?* We conclude that open prototyping is a necessary step, not just for the open design and development, but for the established business practice as well, as it is a way to identify and verify true customer needs.
2. *More specifically, because prototypes validate design concepts, would a process of building prototypes alter the preferences of the members of the community?* We found that identification of the user needs is a subtle matter. It is reasonable to assume that customers will always pursue the “best” product on the market. However, the definition of “best” is different from person to person. Traditional closed-form development processes tend to miss this point. Open prototyping will allow customers to see a product perform before they can know exactly what they want.

3. *Would open manufacturing be possible? Would people trust other people's manufactured parts?* It seems to us that open manufacturing is possible or even plausible, but quite unlikely to happen with the current status of individual manufacturing capabilities. Currently, prototyping and manufacturing capability is present in a spectrum of private businesses, from small “mom and pop” fabrication shops to the manufacturing facilities of original equipment manufacturers. These businesses would have to alter their practices to effectively produce the designs developed by an open collaborative design community. We argue that it will be necessary for them to participate as members of the community, both to influence the designs as they are developing, as well as to win the opportunity to do the fabrication work. This is in contrast to the current environment in which manufacturers largely only produce designs that have already been fully specified. Such a change may be easier for smaller companies, or even skilled individuals possessing shop facilities, such as Mr. Jostin Halford, who was mentioned in Chapter 1. Further research on this matter is necessary.

The material kit and hand tools that we listed in 5.3.3 are generally available within individual's reach. So a toolkit that consist them as well as supporting software would be possible for open prototyping practice. However, some power tools such as lathe, mills, or even CNC, although necessary in most mechanical design prototyping, are generally not available to individuals. Good news is that public accessible workshop like *Techshop*, which we have discussed before, would fill the gap. Further experiment of using this distributed public workshop to conduct online open prototyping is necessary for further exploring open prototyping method.

# Chapter 6

## Conclusion

With these four experiments we covered the entire mechanical design and product development process with open approaches. The openness of the concept generation and the embodiment phases were achieved by conducting them on a web forum, and the openness of the prototyping was achieved by having participants collocated while they worked. After these four experiments, we have a clearer idea of how to conduct open collaborative design projects. We have a more complete understanding of its impact on the design process compared to the traditional “closed” and “face-to-face” methods. In this chapter, I would like to present some conclusions and lessons learned from this research, and hopefully, indicate directions for future in-depth research.

### 6.1 Building and Maintaining the Community

In our experiment, we were using undergraduate students as community members. This community does not closely resemble real online communities, primarily with regard to enthusiasm. However, even with these semi-voluntary participations, we witnessed social loafing and lack of organization that can also be seen in real online communities. The crucial elements leading to a strong and capable community lie in these points.



## 6.1.1 Real People

In most online communities, members are largely known to each other by an alias name. This is fine if the main purpose of the community is just an exchange of opinions. However, in open design communities, members need to know each other more in order to build enough trust and accountability to allow a project to proceed.

We also feel that it is necessary for philosophical leaders in open collaborative design to emerge. In the open software industry, these early leaders included such individuals as Linus Torvalds, Eric Raymond, Tim O'Reilly, and Richard Stallman, etc. As their contribution and capability became known within their online communities, their real name became known and eventually became recognized leaders in that industry. In the open design practice, it seems that entrepreneurial efforts, such as Cambrian House and Kluster, as well as the people behind them, are beginning to serve this role. Until a particular approach to open collaborative design develops a long history of success, however, we believe that standardized procedures will not emerge. More time and experimentation is needed.

At a more fundamental level, we argue that once an open collaborative design project is underway, more complete communication including real-time conferences and even personal meetings should be encouraged among the participants. The online collaboration is only a way to initiate a possible project and help a geographically dispersed crowd to communicate more economically and more efficiently. Although our experiments showed that a simple web forum collaboration is as effective as face to face

meetings if organized correctly, to encourage a high level of participation and promote success, familiarity and trust among participants is crucial. These will be difficult to obtain if only alias names are used. Letting the participants to step out from behind the alias curtain seems to be a necessary step.

### **6.1.2 Project Community Size**

In open design projects, community size matters. Although there is not a fixed-number threshold to ensure a project's success, in our experiments we saw that it was often difficult to find enough "players" to do all the necessary "heavy lifting" tasks of the projects, and provide leadership. Apart from our efforts, there are other examples of this effect, notably the Assignment Zero journalism project (Howe, 2007)

### **6.1.3 Investors and Manufacturers**

Unlike the open source software industry, general open collaborative design practice needs investors and manufacturers to achieve open design results. Software, unlike tangible artifacts, can be reproduced at relatively zero cost. For open collaborative design, either the project is initiated by an established business, or there are entrepreneurs willing to invest in the design and necessary prototyping/manufacturing. It is very important to have those entrepreneurs like Kluster, or Mr. Halfold to do the prototyping and manufacturing tasks. Even when such manufacturing capabilities exist, many projects will not enter this stage because they are not good enough to justify the

cost. This is one difference between open design practice and the open source software practice: poorly designed software, once developed can be duplicated and distributed very cheaply.

#### **6.1.4 Making Money or Having Fun?**

For the company sponsored projects, it is all about making money. After all, business is business. As for community founded projects, as Powazek (2007) stated, “it is all about fun,” although making money is still an objective. What makes these two kinds of projects similar is that there should be enough interest existing among community participants. Otherwise, the community is not sustainable.

#### **6.1.5 Using an Established Community**

There are many established communities that are focusing on a specific product. For example, the British-manufactured small car *Mini*<sup>38</sup> and a SUV manufactured by Honda<sup>39</sup> both have enthusiastic online user communities. These communities are very large and members have intensive knowledge of that specific product which is shared intensively within the community. Although these communities were started by product enthusiasts, companies making these products could readily tap into these communities for ideas and inspiration. Using these communities to develop new products or

---

<sup>38</sup> [www.mini2.com](http://www.mini2.com)

<sup>39</sup> [www.hondapilot.org](http://www.hondapilot.org)

accessories using an open collaborative design approach would be a natural place to start.

## **6.2 Choosing community Projects**

The subject of the project matters! Two past projects discussed in the prototyping chapter, the *Bevy* and *Overthere*, conducted using the same process, with similar crowds, have quite different results. One (*Bevy*) had a huge financial success in a short period; the other is yet to prove itself. I think the *Bevy* owe its success to the fact that it is an accessory of another famous and well-sold product, IPOD *shuffle*. The customer base for *Bevy* is significantly larger than that of an unknown game, *Overthere*. If seeking financial success is the main objective (as many open design entrepreneurial companies such as Kluster and Cambrian House are), choosing the right product to start is very important.

## **6.3 Effectiveness of the Online Product Development tools**

In his dissertation, Sawhney (2003) emphasized the importance of the effectiveness of the online product development tools. However, our experiments showed that the effectiveness of the online product development tools is important but not crucial for open design projects. The Wedesign forum I implemented is very preliminary with limited functionality to fit our research requirements. This had created some problems

and dissatisfaction among our participants. In the end, however, the online design tasks had been carried out to the same degree as they were with the face-to-face method. This suggests that the effectiveness of the communication among participants is the most important factor. The online product development tools, if designed carefully with an ability to adjust to the participants' needs, would greatly enhance the effectiveness of the online product design.

## **6.4 Lesson Learned from Experiments**

This research was begun with a goal of finding the right way to convey local “sticky” information to the manufacturer in order to better use customer generated solutions into mass produced products. Along the way I found other theories and practices that would enhance the benefit of using user wisdom even more. However, it also became clear that the open design method is a rather large topic, and my research efforts can only address certain aspects of the issue. Here is what I think are the lessons learned from the experiments.

### **6.4.1 Finding Leaders or Imposing Project Management**

A lot of communities' projects intended to be self-run have failed. By dividing large tasks into smaller hopefully self-manageable ones, I thought we could lower the failure rate and still allow the community members to run the project without imposed

leadership or management. However, the results are less than satisfactory. Only in those cases in which leaders did emerge, did the project run its whole course and we see relatively satisfactory results. Others all failed because of lack of participation. I wonder if imposing some kind of management, the researcher as a project leader for example, would make a difference both on the participation and design results. For a future research activity, I would suggest an experiment comparing managed face to face design with managed threaded online design.

### **6.4.2 Project Group Size**

Our experiment results perhaps suffered from the limited number of research subjects. The numbers of students used in these experiments were not enough to establish sufficient statistic power for our research. Open design projects in the real world are usually carried out by a large pool of participants. If we have to use academic settings for future research activity, then we may need to employ students from larger pools of subjects, such as from a number of engineering schools. This could create difficulty with experiment management and possible human subject research monitoring. However, doing a larger-scale study is important for further research on the open design method.

### **6.4.3 Real World Experiment**

In the end, the open design method can only be proved an effective way of conducting product development by ample real world success of implementing such design

techniques. There are some sample success stories already, but they are not enough to draw concrete conclusions. Due to the inherent shortcomings of using academic settings, notably subjects lacking passion of participation, the results are not necessarily transferable to the real world business practice. Further research is needed.

# Appendix A

## Idea Generation: Exit survey

### Comparing Small Group Performance on Engineering Design Tasks Done with Face-to-Face and Web-Forum Modes

*Please feel free to provide additional comments for any of the questions.*

1. (FTF, WeDesign) Which mode was assigned to your team?
2. (\_\_\_\_\_ ideas) By your counting, how many ideas did your team produce?
3. (\_\_\_\_\_ ideas) How many ideas do you think you yourself produced *during the team interaction phase*? You could have produced these independently of your teammates or you could have come up with an idea in response to something a teammate did. If a teammate independently came up with the same idea, still count it as one you created. What is the total number you produced during team interaction?
4. (\_\_\_\_\_ Ideas) Among the number reported in 4, how many did you come up with that were strictly in response to something that a teammate did?
5. (Yes, No) Did you ever have trouble expressing or explaining an idea to your teammates? *The idea could have been from either the preliminary individual phase or the team interaction phase.* This is different from being afraid to express an idea, which is dealt with in questions 8-10 below.
6. In one sentence, please describe the nature of this difficulty.
7. (Yes-lost it, No-didn't happen) Do you believe that you had an idea, but somehow forgot it or "lost it" before you were able to communicate it to your teammates (therefore, it is not in the total reported in question 3)? *The idea could have been from either the preliminary individual phase or the team interaction phase.*



8. (Yes, No) Were you ever afraid to express an idea to your teammates? *The idea could have been from either the preliminary individual phase or the team interaction phase.*
9. In one sentence, please explain why you were afraid.
10. (Never-got-included, Eventually-got-included) If you withheld an idea because you were afraid to express it, did this idea eventually never get included in the set your team produced?
11. (\_\_\_\_\_ ideas) How many ideas that you withheld (out of fear) never got included?
12. Very briefly, please describe the process that your team used to complete this idea generation part of the experiment.
13. Please feel free to provide any other comments.

Thank You!

# Appendix B

## Embodiment: Exit survey

### Comparing Small Group Performance on Engineering Design Tasks Done with Face-to-Face and Web-Forum Modes

*Please feel free to provide additional comments for any of the questions.*

1. (FTF, WeDesign) Which mode was assigned to your team?
2. (Completed, Not completed) Do you feel that your team substantially completed the embodiment process in the time given, or was there a lot of work left undone?
3. (Good job, NOT good job) Do you feel that your team did a good job on the work that was completed (i.e. if done as coursework, would it earn a good grade)?
4. (Fair, not fair) Do you feel that the work was divided among the team. members fairly (everyone had approximately the same amount of work to do)?
5. Please very briefly describe the process your team used to divide up the work.
6. (Yes, No) Did your team explicitly review all work done at the end of the process, e.g. to discover mistakes and omissions?
7. Please very briefly describe how this review was done.

8. (Yes-leaders emerged, No-didn't emerge) Do you feel that some members of your team assumed leadership roles during the process?
9. (Yes-emerged leaders helpful, No-emerged leaders not helpful, Not applicable-no leaders emerged) If leaders did emerge, was it useful in getting the work done satisfactorily?
10. (Yes, No) Were you able to adequately communicate with your teammates?
11. (phone, fax, texting, email, video chatting, face-to-face) What single communication medium (that you did not have) would have been most useful? Please choose one option from the list.
12. Very briefly, please describe the process that your team used to complete this part of the experiment.
13. From your experiences in completing this exercise, please provide us recommendations in how to provide instruction in team-based design embodiment.

Thank You!

# Appendix C

## Prototyping Survey

### Before-Contest Survey

#### Observation of Group Behavior During “Open Source” Design and Fabrication of Physical Artifacts

1. Have you ever heard the term “open source” before? (Yes, No)
2. Have you ever heard the term “crowdsource” before? (Yes, No)
3. In a typical MASE 101 design contest, would you prefer to work in a group, or work alone? (Group, Alone). Feel free to provide comments.
4. During a typical MASE 101 contest, if you saw someone else’s design (at any stage of development), and thought it was better than yours, would you abandon your design and implement theirs? Assume there is no penalty for doing so. (Abandon, Keep my design). Feel free to provide comments.
5. Would you feel comfortable having other students build parts (not completely build it) of your contest machine for you? (Yes, No). Please feel free to provide comments.
6. Would you feel comfortable having other students completely build (*i.e.* all parts and final assembly) your contest machine for you? (Yes, No). Please feel free to add comments.
7. On a scale of 1 . . . 10 (1 = bad, 10 = excellent), please rate your drawing skills. (Drawing skills = \_\_\_\_\_).
8. On a scale of 1 . . . 10 (1 = bad, 10 = excellent) please rate your shop skills. (Shop skills = \_\_\_\_\_).

9. When the concept sketches are due, assume that all students reviewed all concept sketches and voted to determine the best one (no faculty input). Also, assume that a single design got a majority of the votes. Do you think the results of the vote would accurately pick the best idea? (Yes, No). Please feel free to provide comments.
10. Would you choose to build the design that won the vote, or would you stay with your own? (Build winner, Stay with own). Please feel free to provide comments.

## After-Contest Survey

### Observation of Group Behavior During “Open Source” Design and Fabrication of Physical Artifacts

1. Which of the following most closely describes how members of your group completed their contest machines. Please choose only one.
  - a. Nothing open. All machines **completely** built by individuals. This is the same as a conventional contest.
  - b. Prebuilt (*e.g.* concept sketches) open. All machines **completely** built by individuals
  - c. Prebuilt open. **Some** parts built communally. Final assembly built by individuals.
  - d. Prebuilt open. **Most** parts built communally. Final assembly built by individuals.
  - e. Prebuilt open. **All** parts built communally. Final assembly built by individuals.
  - f. Prebuilt open. All machines **completely** built communally. (*i.e.* like an assembly line)
  - g. Other. Please provide a short description.
2. Were you satisfied with how your group completed its work (*i.e.* the answer to question 1)? (Yes, No)

3. If you had it to do all over again, which of the options in question 1 would be the best work mode? (a,b,c,d,e,f,g). If choosing g, please provide a short description.
4. Imagine that the machines built in the contest had potential market value. Would you be willing to work in any kind of open mode? In this case the group would share any economic benefit (Yes, No)
5. Do you feel like you worked more or less than you would have in the same contest done conventionally? (More, Less, Same)
6. Do you feel like everyone in your group worked about the same amount? (Yes, No). Do you feel that the workload distribution was fair (Yes, No)
7. Do you feel that members of a group that worked less should somehow compensate the members of the group that worked more? (Yes, No). Do you have any ideas of how to do this?
8. If you used parts made by other students, were they made well enough? (Yes, No). If not, what did you do about it?
9. Did all the machines made by members of your group perform about equally well? (Yes, No).
10. Did anyone in your group use information from other group members that “opened-up” more than they did? (*i.e.* they “took” more than they “give”) (Yes, No). Is this a problem? (Yes, No)

## References

- Addis, M. & Holbrook, M.B. (2001). "On Conceptual link between mass customization and experiential consumption: An Explosion of Subjectivity," *Journal of Consumer Behaviour*, 1(1), 50-66.
- Agrawal, M., Kumaresh, T.V., and Mercer, G.A., 2002. "The false promise of mass customization" *The McKinsey Quarterly*, 2001. Number 3, Page 62-71.
- Amabile, T. M. 1982, "The Social Psychology of Creativity: A Consensual Assessment Technique." *Journal of Personality and Social Psychology* 43 (1982): 997-1013.
- Bandula, S. Z, Bandula, D. (2002) "Virtual Prototype in Ship Design" Symposium on Theory and Practice in Shipbuilding, Trogir 2002.
- Bacon, G., Beckman, S., Mowery, D., Wilson, E., 1994. "Managing Product Definition in High-Technology Industries," *California Management Review* 36 (Spring 1994): 32-56
- Bailey MJ. (1995) Tele-manufacturing: rapid prototyping on the Internet. *IEEE Computer Graphics and Applications* 1995; November: 20–26.
- Boldrin, M. and D.K. Levine (2005), *The Economics of Ideas and Intellectual Property*, *Proceedings of the National Academy of Sciences*, 102, 1252.1256.
- Boutellier, R, Gassmann, O, Macho, H, Roux, M, 1998, "Management of Dispersed Product Development Teams: The Role of Information Technologies," *R&D Management* 1998; 28:13-25
- Coffin, Jill. 2006. Analysis of open source principles in diverse collaborative communities. *First Monday*, volume 11, number 6 (June 2006), [http://firstmonday.org/issues/issue11\\_6/coffin/index.html](http://firstmonday.org/issues/issue11_6/coffin/index.html)
- Cox, M. W. and Alm, R., 1998, *The Right Stuff: America's Move to Mass Customization*, Annual Report, Federal Reserve Bank of Dallas.
- Christensen, C. M. (1997), *The Innovator's Dilemma. When new Technologies cause great Firms to fall*, Boston (MA): Harvard Business School Press.

Diehl, M & Strpebe, W, 1987, "Productivity Loss In Brainstorming Groups: Toward the Solution of a Riddle", *Journal of Personality and Social Psychology* 1987, Vol. 53, No. 3, 497-509

Dollinger, Stephen. and Shaferan, Marina., 2005. "Note on Consensual Assessment Technique in Creativity Research" *Perceptual and Motor Skills*, 2005, 100, 592-598.

Dubiansky, John. 2006 *The Role of Patents in Fostering Open Innovation*, *Virginia Journal of Law & Technology*, Vol. 11, No 7. Fall 2006

Fodor, E.M., and Carver, R.A., 2000. Achievement and power motives, performance feedback, and creativity. *Journal of Research in Personality*, 34, 380-396.

Franke, N. and Piller, F. (2004) Toolkits for user innovation and design: an exploration of user interaction and value creation. *Journal of Product Innovation Management*, 21, 401-415.

Franke, N. & Piller, F. 2004. Value Creation by Toolkits for User Innovation and Design: The Case of the Watch Market. *J. of Product Innovation Management*. Vol. 21. 401-415.

Franke, N, and Schreier, M (2002), "Entrepreneurial Opportunities with Toolkits for User Innovation and Design" *The International Journal on Media Management*, 2002, Vol. 4, No. 4, pp. 225-235.

French M.J, 1971, *Engineering Design: The Conceptual Stage*, Heinemann Educational (1971)

Gallupe, R.B, Dennis, A.R, Cooper, W.H, Valacich, J.S, Bastianutti, L.M, Nunamaker, J.F.Jr, 1992, "Electronic Brainstorming and Group Size", *Academy of Management Journal*, Vol. 35, No 2, pp. 359-369.

Gilmore, J.H. and Pine, B.J. (1997) "The Four Faces of Mass Customization," *Harvard Business Review*, (Jan-Feb), 91-101.

Griffin, Abbie, and John R. Hauser, 1993, "The Voice of the Customer" *Marketing Science*, Vol. 12, No. 1, Winter 1993, pp.1-27.

Hargadon, Andrew. 2003, *How Breakthroughs Happens: The Surprising Truth About How Companies Innovate*. Harvard Business School Press. 2003

Hennessey, B. A, Amabile, T. M. 1999 "Consensual assessment" *Encyclopedia of Creativity*. Volume 1, pp 347~359

Howe, Jeff. 2006, *The Rise of Crowdsourcing*. *Wired Magazine*, Issue 14.06 - June 2006  
[http://www.wired.com/wired/archive/14.06/crowds\\_pr.html](http://www.wired.com/wired/archive/14.06/crowds_pr.html)



Howe, Jeff, 2007, Did Assignment Zero Fail? A Look Back and Lessons Learned. Wired Magazine, 07.16.07.  
[http://www.wired.com/techbiz/media/news/2007/07/assignment\\_zero\\_final](http://www.wired.com/techbiz/media/news/2007/07/assignment_zero_final)

Jacobs P. (1992). Rapid Prototyping and Manufacturing: Fundamentals of Stereolithography, vol 1. Dearborn, MI: Society of Manufacturing Engineers, 1992.

Jakiela, M. J., Zheng, J., 2008, "WeDesign: A Forum-Based Tool for Managing User-Generated Content in Engineering Design and Product Development," DETC2008-50107, Proceedings of the 2008 ASME Design Engineering Technical Conferences and Computers and Information in Engineering Conference: Volume 4, 20th International Conference on Design Theory and Methodology (DTM); and 2nd International Conference on Micro- and Nanosystems (MNS), pages 711-717.

Kelly, Thomas., Littman, Jonathan. 2005. *The Ten Faces of Innovation: IDEO's Strategies for Defeating the Devil's Advocate and Driving Creativity Throughout Your Organization*. Broadway Business (October 18, 2005)

Lakhani, K. R., L. B. Jeppesen. 2007. Getting unusual suspects to solve r&d puzzles. Harvard Business Review 85(5) 30-32.

Latané, B, Williams, K, Harkins, S. 1979, "Many Hands Make Light the Work: The Causes and Consequences of Social Loafing" Journal of Personality and Social Psychology. 1979, Vol 37, No 6, 822~832.

Ligorio, M.B, 2001, "Integrating communication formats: synchronous versus asynchronous and text-based versus visual." Computers & Education, Science Direct, volume 37, Issue 2, September 2001, pages 103-125.

Meyer, K. A. 2003, "Face-to-Face versus Threaded Discussions: The Role of Time and Higher-Order Thinking. Journal of Asynchronous Learning Networks, Volume 7, Issue 3. September 2003.

Mullen, Brian, Johnson, Craig and Salas, Eduardo., 1991, 'Productivity Loss in Brainstorming Groups: A Meta-Analytic Integration', Basic and Applied Social Psychology, 12:1,3 — 23

Nunamaker, J.F., Dennis, A.R., Valacich, J.S., Vogel, D.R., & George, J.F. 1991, Electronic meeting systems to support group work. *Communications of the ACM*, 34(7); 40-61.

Ocker, R.J, Yaverbaum, G.J, 1999, "Asynchronous Computer-mediated Communication versus Face-to-face Collaboration: Results on Student Learning,

Quality and Satisfaction.” *Group Decision and Negotiation*, Volume 8, Number 5 / September, 1999. pp 427-440.

Ogawa, S. and Frank Piller., 2006, “Reducing the Risks of New Product Development”. *MIT Sloan Management Review* (2006). Vol. 47, No. 2, pp. 65-71. <<http://sloanreview.mit.edu/smr/issue/2006/winter/14>> Accessed 21 November 20

Pahl, G & Beitz, W, 1996, *Engineering Design: A Systematic Approach*, Published by Springer 1996, second edition.

Paulus, Paul B. and Yang, 2000, “Idea Generation in Groups: A Basis for Creativity in Organizations.” *Organizational Behavior and Human Decision Processes* Vol. 82, No. 1, May, pp. 76–87, 2000

Piller, F.T. & D. Walcher. 2006. Toolkits for Idea Competitions: A Novel Method to Integrate Users in New Product Development. *R&D Management* 36, 307-318.

Pine, Joseph B. II. 1993. *Mass Customization: The New Frontier in Business Competition*, Cambridge, MA: Harvard Business School Press 1993.

Poolton, J. and Barclay, I., 1998. “New Product Development from Past Research to Future Applications,” *Industrial Marketing Management* 27, no. 3 (1998): 197-212

Powazek, Derek, 2007. Did Assignment Zero Work? <http://powazek.com/posts/622>

Raymond, E.S, 2000, “ The Cathedral and the Bazaar”, version 3.0, Thyrus Enterprises [<http://www.tuxdedo.org/~esr/>]

Reinmoeller, P. 2002, “Dynamic Contexts for Innovation Strategy: Utilizing Customer Knowledge,” *Design Management Journal Academic Review* 2, no. 1 (2002): 37-50.

Riverside, J. (2007, January 7). “Open Source CAD Software.” Retrieved March 8, 2009, from <http://ezinearticles.com/?Open-Source-CAD-Software&id=408192>

Rix, J. Haas, S. Teixeira, J. (1995) *Virtual prototyping: virtual environment and the product design process*. Chapman Hall, New York, 1995.

Sawhney, Nitin. 2003, *Cooperative Innovation in the Commons: Rethinking Distributed Collaboration and Intellectual Property for Sustainable Design Innovation*. Cambridge, MA: Doctoral dissertation, Massachusetts Institute of Technology.

Sawyer, K, “Group Flow”, *Group Genius: The Creative Power of Collaboration*. Published by Basic Books, 2007. pp 39~57.

Schonfeld, E, 2008, "First Look: Kluster's Market Approach to Crowdsourcing", TechCrunch, February 18, 2008. <http://www.techcrunch.com/2008/02/18/first-look-klusters-market-approach-to-crowdsourcing/>

Schonfeld, E, 2008, "When Crowdsourcing Fails: Cambrian House Headed to the Deadpool", TechCrunch, May 12, 2008. <http://www.techcrunch.com/2008/05/12/when-crowdsourcing-fails-cambrian-house-headed-to-the-deadpool/>

Seron, F. J, Gutierrez, D, Magallon, J. A, Sobrevela, E. J, Gutierrez, J. A, (2004) "A CAVE-like environment as a tool for full-size train design." *Virtual Reality* (2004) 7: 82-93. DOI 10.1007/s10055-003-0117-6

Stallman, Richard. 2007, Why "Open Source" misses the point of Free Software. <http://www.gnu.org/philosophy/open-source-misses-the-point.html>.

Suthers, D. Girardeau, L. Hundhausen, C. 2003 "Deictic roles of external representations in face-to-face and online collaboration." *Designing for Change in Networked Learning Environments*, Proceedings of the International conference on Computer Support for Collaborative Learning 2003, Kluwer Academic Publishers, pp. 173-182.

Tellioglu, H., Wagner, I. and Lainer, R (1998) *Open Design Methodologies. Exploring Architectural Practice for Systems Design*. Proceedings of PDC'98, Seattle. 19-28

Thomke, S. and von Hippel, E. 2002, Customers as Innovators: A new Way to Create Value, in: *Harvard Business Review*, Vol. 80, No. 4, (April), pp. 74-81.

Toubia, O. and Flores, L. 2006, "Adaptive Idea Screening Using Consumers" Working Paper, Columbia Business School, New York, NY.

Ulrich, K. & T, Eppinger, S. D. 2003, *Product Design and Development*. McGraw-Hill, 2003. Third Edition.

von Hippel, E. (1986). Lead Users: A Source of Novel Product Concepts. *Management Science*, 32(7), 791-805

von Hippel, E. (1994). "Sticky Information" and the Locus of Problem Solving: Implications for Innovation. *Management Science*, 40(4), 429-439

von Hippel, E. and Katz, R. (2002) Shifting innovation to users via toolkits. *Management Science*, 48, 821-833.

von Hippel, Eric (2001). Perspective: User Toolkits for Innovation. *Journal of Product Innovation Management* 18(4):247–257.

West, J & O'Mahony S, 2005, "Contrasting Community Building in Sponsored and Community Founded Open Source Projects." *Proceedings of the 38th Hawaii International Conference on System Sciences -2005*

Yang, M. C., and Cham, J. G., 2007, "An Analysis of Sketching Skill and its Role in Early Stage Engineering Design," *ASME J. Mech. Des.*, 129(5), pp. 476–482

Yang, M.C, Jin, Y, 2008, "An Examination of Team Effectiveness in Distributed and Co-located Engineering Teams" *International Journal of Engineering Education*, 2008, pp. 400~408.

Zheng, J., Jakiela, M. J., 2009a, "An Investigation of the Productivity Difference in Mechanical Embodiment Design Between Face-to-Face and Threaded Online Collaboration," DETC2009-87070, in *Proceedings of the ASME 2009 International Design Engineering Technical Conferences and Computers and Information in Engineering Conference*, San Diego, CA, August 30 - September 2, 2009 [CD-ROM], ASME 2009, 10 pages.

Zheng, J., Jakiela, M. J., 2009b, "An Investigation of the Productivity of Individual, Face-to-face, and Threaded Online Collaboration on Mechanical Product Concept Development," Submitted for review to the *Artificial Intelligence for Engineering Design, Analysis, and Manufacturing* journal special issue on Creativity: Simulation, Stimulation, and Studies (Vol. 24, No. 2), Spring 2010.

Zheng, J., Jakiela, M. J., 2009c, "An Open Collaborative Prototyping / Manufacturing Experiment in Mechanical Engineering Design: A Step that Attempted to Complete the Open Product Design and Development Process Cycle," Working paper to accompany presentation at the *International Open and User Innovation Workshop 2009*, Hamburg, Germany.

Zorriassatine, F; Wykes, C; Parkin, R; Gindy, N. 2003. "A survey of virtual prototyping techniques for mechanical product development." *Proceedings of the Institution of Mechanical Engineers -- Part B -- Engineering Manufacture*, Apr2003, Vol. 217 Issue 4, p513-530, 18p;

# Vita

## Jing Zheng

- Date of Birth**    October 15, 1971
- Place of Birth**    Zhuzhou, China
- Degrees**            Graduate Diploma, Aerospace Engineering, July 1992  
M.S. Mathematics, December 2000  
D.Sc. Mechanical, Aerospace and Structural Engineering, Aug 2009
- Professional Experience**    *Senior Optical Network Engineer*    Nov 2000~Dec 2003  
Corvis Cooperation, Columbia, Maryland, USA
- Senior System Engineer*                    Feb 1997~Sept 1998  
Hangzhou ECI Telecom Co, Ltd. Hangzhou, China
- System Engineer*                                    Feb 1995~Jan 1997  
Shanghai ONFLO Software Company, Shanghai, China
- Software Engineer*                                    Aug 1992~Jan 1995  
Hangzhou KEDI Computer Institute, Hangzhou, China
- Mechanical Design Engineer*                    Aug 1992~Jan 1995  
(Part time) ShanDong Tai'an Gypsum Plaster Board Manufacturing,  
Tai'an, China
- Publications**            Jakiela, M. J., Zheng, J., 2008, "WeDesign: A Forum-Based Tool for Managing User-Generated Content in Engineering Design and Product Development," DETC2008-50107, Proceedings of the 2008 ASME Design Engineering Technical Conferences and Computers and Information in Engineering Conference: Volume 4, 20th International Conference on Design Theory and Methodology (DTM); and 2nd International Conference on Micro- and Nanosystems (MNS), pages 711-717.

Zheng, J., Jakiela, M. J., 2009a, "An Investigation of the Productivity Difference in Mechanical Embodiment Design Between Face-to-Face and Threaded Online Collaboration," DETC2009-87070, in Proceedings of the ASME 2009 International Design Engineering Technical Conferences and Computers and Information in Engineering Conference, San Diego, CA, August 30 - September 2, 2009 [CD-ROM], ASME 2009, 10 pages.

Zheng, J., Jakiela, M. J., 2009b, "An Investigation of the Productivity of Individual, Face-to-face, and Threaded Online Collaboration on Mechanical Product Concept Development," Submitted for review to the Artificial Intelligence for Engineering Design, Analysis, and Manufacturing journal special issue on Creativity: Simulation, Stimulation, and Studies (Vol. 24, No. 2), Spring 2010.

Zheng, J., Jakiela, M. J., 2009c, "An Open Collaborative Prototyping / Manufacturing Experiment in Mechanical Engineering Design: A Step that Attempted to Complete the Open Product Design and Development Process Cycle," Working paper to accompany presentation at the International Open and User Innovation Workshop 2009, Hamburg, Germany.

August 2009

**Open Collaborative Design Method, Zheng, D.Sc. 2009**