

Washington University in St. Louis

## Washington University Open Scholarship

---

All Computer Science and Engineering  
Research

Computer Science and Engineering

---

Report Number: WUCS-89-39

1989-09-01

### The Video Link Design Study

William D. Richard

The video link concept is a proposed method for providing video codec service to the customer base in a manner similar to the way phone service is provided today. Three possible implementations are low volume solutions that could be used to test market the video link concepts. The third method, which is technically superior to the first two, would only be economically feasible in a high volume implementation.

Follow this and additional works at: [https://openscholarship.wustl.edu/cse\\_research](https://openscholarship.wustl.edu/cse_research)

---

#### Recommended Citation

Richard, William D., "The Video Link Design Study" Report Number: WUCS-89-39 (1989). *All Computer Science and Engineering Research*.  
[https://openscholarship.wustl.edu/cse\\_research/750](https://openscholarship.wustl.edu/cse_research/750)

Department of Computer Science & Engineering - Washington University in St. Louis  
Campus Box 1045 - St. Louis, MO - 63130 - ph: (314) 935-6160.

THE VIDEO LINK DESIGN STUDY

William D. Richard

WUCS-89-39

September 1989

Department of Computer Science  
Washington University  
Campus Box 1045  
One Brookings Drive  
Saint Louis, MO 63130-4899

This work was supported by Southwestern Bell Telephone.

**THE VIDEO LINK DESIGN STUDY**

**William D. Richard**

**WUCS-89-39**

**September 1989**

**Department of Computer Science  
Washington University  
St. Louis, Missouri 63130**

**This work was supported by Southwestern Bell Telephone**



## Abstract

The video link concept is a proposed method for providing video codec service to a customer base in a manner similar to the way phone service is provided today. Three possible implementations of the video link are described. The first two implementations are low volume solutions that could be used to test market the video link concept. The third method, which is technically superior to the first two, would only be economically feasible in a high volume implementation.

## 1 Introduction

The goal of the Video Link Design Study was the specification of design alternatives for a fiber optic video link system capable of providing video codec service to commercial and/or residential telephone customers. The proposed system would use fiber optic links to transmit either digital or analog video to (from) a telephone company vault or central office from (to) the customer site. At the telephone company site, a switch would provide connection to a bank of video codecs. This scheme allows the cost of the video codecs to be shared by many customers, and the telephone company would recover costs by charging for the service. The advantages of this scheme are further enhanced if the cost of the customer premise equipment can be kept low.

The overall architecture of the proposed fiber optic video link is shown in Fig. 1. Customer premise equipment would consist of a video camera, a video monitor, and two interface (I/F) modules. The first I/F module provides the interface between the video camera and the fiber carrying video information to the telephone company vault or central office. The second I/F module provides the interface between the fiber carrying video information from the telephone company vault or central office to the customer site. These two interface modules could be integrated into one physical unit in the final product.

The telephone company vault or central office would contain a pair of I/F modules for each incoming fiber pair, a switch, and a bank of video codecs. The I/F modules provide the interface between the fiber optic cables carrying the video information and the switch. The switch establishes the connection between the customer and the codec pool.

The three methods investigated during the video link design study for implementing the fiber optic video link are

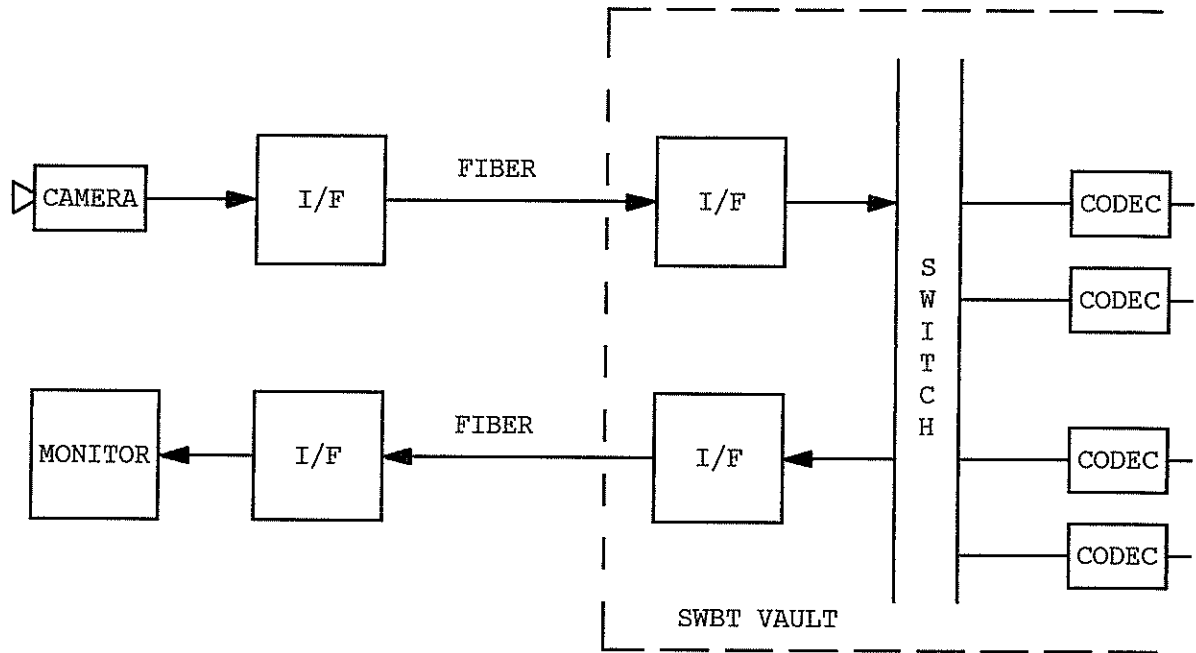

Fig. 1. The Video Link Concept

outlined below. The first two methods are considered to be low volume options. These options could be used to test market the video link concept. The third option is considered to be the best when high volume system usage is anticipated. This option does, however, require interaction with a video codec vendor or in-house development of equivalent technology.

## 2 Low-Volume Option: Analog Transmission Via RCA Fiber Optic Links

This implementation of the video link, shown in Fig. 2., would transmit (receive) analog video to (from) standard video codecs via an analog switch using RCA Fiber Optic Link Video Transmitters and RCA Fiber Optic Link Video Receivers [1]. In this implementation, RCA Fiber Optic Link Video Transmitter/Receiver pairs would be located at the customer site and at the codec site in order to provide two-way video capability.

The RCA Fiber Optic Link Video Transmitter accepts standard base-band video input and directly drives 50/125 um multi-mode fiber. The RCA Fiber Optic Link Video Receiver accepts the multi-mode fiber output and generates standard base-band video. Each of these modules measures 6.4 x 12 x 3.2 cm, and each requires an external 24 VAC wall-type transformer. An RCA Fiber Optic Link has a system bandwidth of 10 MHz.

The switch used in this implementation would be required to switch base-band analog video. Base-band analog video is the standard form of input to, and output from, a video codec. In this sense, an analog switch is desirable. The use of an analog video switch does, however, make this implementation incompatible with future digital switching options.

Excluding the video camera and monitor, the customer premise equipment cost for this implementation would be approximately \$600 when purchased in low volume quantities. The system would handle color (NTSC) and black-and-white (RS-170) video and allow simple loop-through to the local user via the analog switch. Local loop-through would provide full-bandwidth video to local users.

The use of multi-mode fiber would limit the transmission distance of this implementation to approximately three miles without amplification. Upgrading the system to single-mode electronics would increase the cost by approximately \$2000 per node.

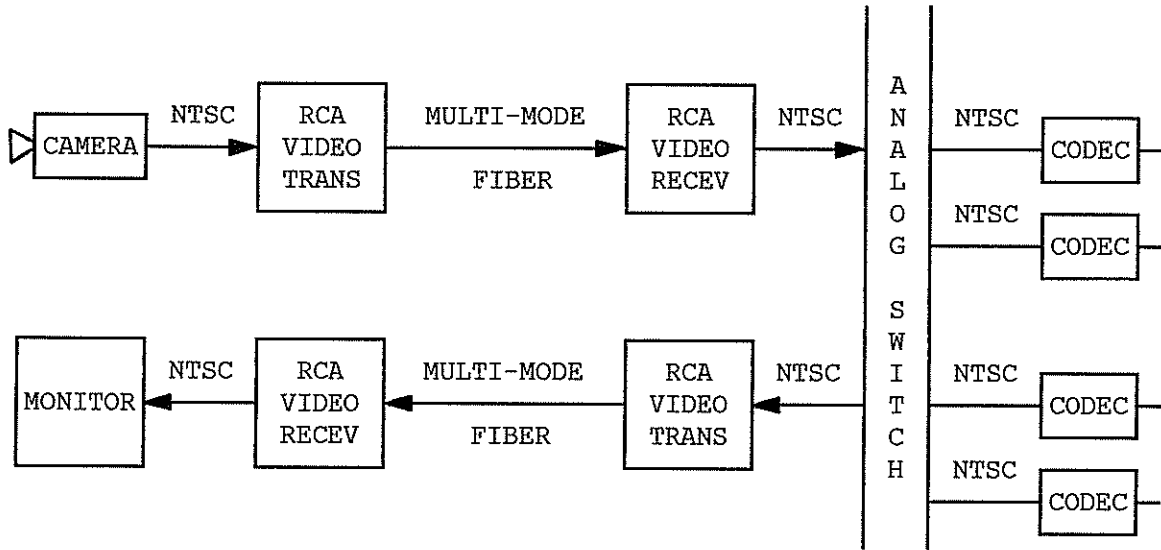

Fig. 2. Low Volume Option: Analog Transmission via RCA Fiber Optic Links



### 3 Low Volume Option: Digital Transmission Via TAXI

The Advanced Micro Devices TAXI (Transparent Asynchronous X-mitter Receiver Interface) chip set [2] is a general purpose interface for 4.0 to 12.5 MBytes/sec point-to-point serial communications over coaxial or fiber media. The TAXI transmitter accepts 8-, 9-, or 10-bit parallel input data and transmits it serially at 125 Mbits/sec via differential ECL outputs. A 4B/5B encoding scheme is used for 8-bit data, resulting in a data transfer rate of 100 Mbits/sec. The TAXI receiver accepts differential ECL inputs and decodes the parallel data sent by the transmitter. The transmitter/receiver pair thus operates as a pseudo-parallel register.

When the TAXI chip set is used with fiber optic cable, an optical data link (ODL) pair is used to provide access to the fiber media. The AT&T ODL 200 Lightwave Data Link pair [3] is one example of currently available devices. The ODL 200 transmitter accepts differential ECL inputs and drives standard multi-mode fiber directly. The receiver has a multi-mode input and differential ECL outputs. Both components are designed to operate up to 220 Mbits/sec. Both devices are packaged in 16-pin dual in-line packages and have integral ST series fiber optic connectors.

The low volume TAXI implementation, shown in Fig. 3., would use a TAXI transmitter to form a digital fiber optic link transmitter at the customer site. Three Analog Devices AD9502 Hybrid Video Digitizers [4] would be used to digitize video from an RGB camera. These 40-pin dual in-line hybrid components contain all the circuitry necessary to convert base-band monochrome video directly into 8-bit digital information. The upper six bits of each digitizer's output would be forwarded to the TAXI transmitter for transmission.

A TAXI receiver, a frame buffer, and a triple video DAC would be used at the customer site to regenerate received video. Received video would be displayed using an RGB monitor. With an optional RGB-to-NTSC converter, standard television monitors could be used for image display.

A TAXI transmitter/receiver pair would also be used at the codec site, where switching would be done via a digital switch. Connection between TAXIs would be via multi-mode fiber. AT&T ODL 200 units, or equivalent, would provide interface to the fiber optic cable.

In order to generate the NTSC video format required by standard video codecs, a frame buffer, triple video DAC, and an RGB-to-NTSC converter would be used in front of the transmitting video codec to form NTSC video from the transmitted digital RGB video information.

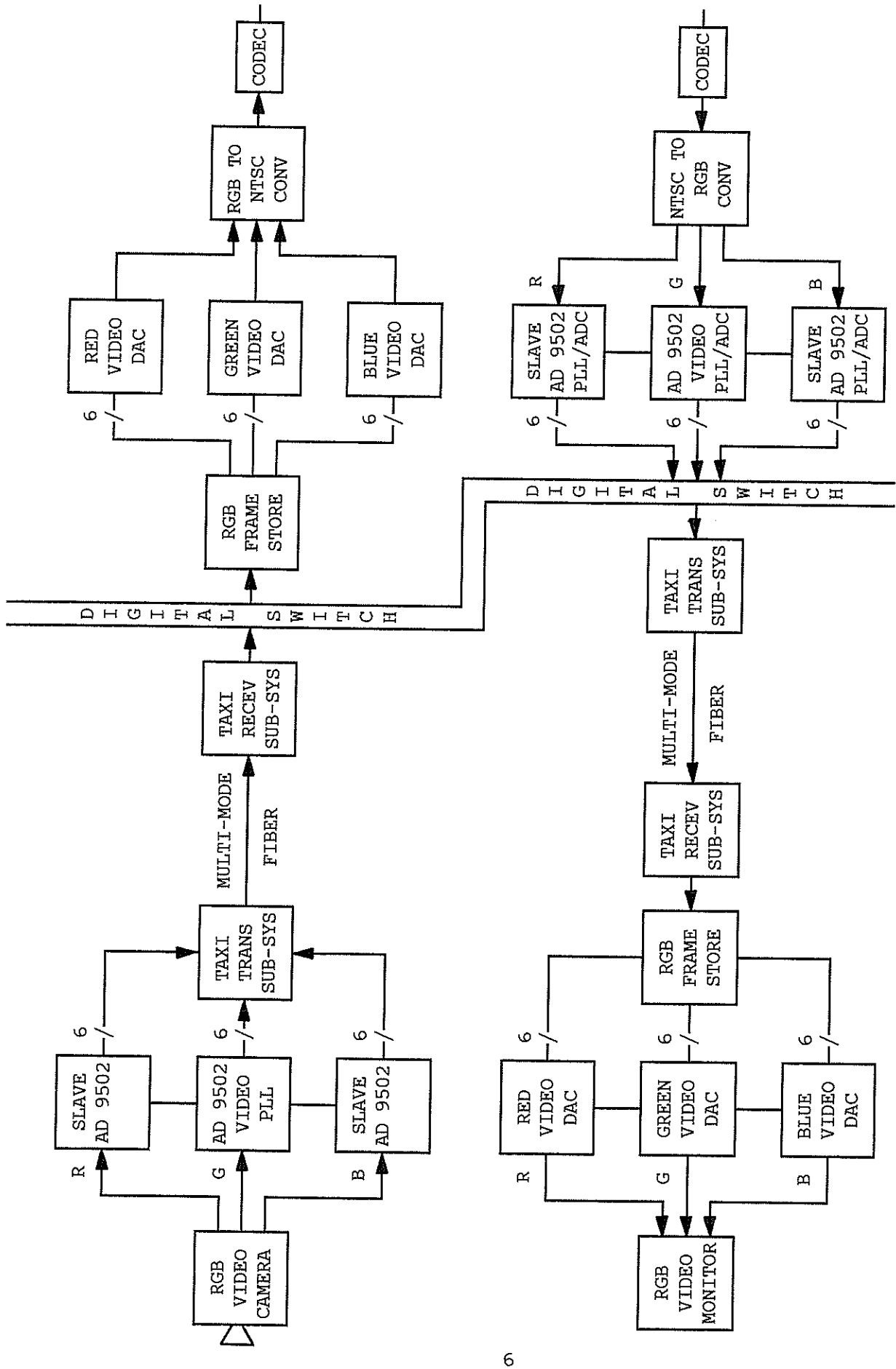

Fig. 3. Low Volume Option: Digital Transmission Via Taxi

Before being sent to the TAXI transmitter via the digital switch, the base-band NTSC video output from a video codec would be converted to RGB format, via an NTSC-to-RGB converter, and digitized via three AD9502s. This step would be required since the output from a standard video codec is base-band video.

Without requiring the use of costly compression techniques, this implementation, using a single multi-mode fiber pair, could provide 320(H) x 480(V) x 18-bit video using very simple, relatively inexpensive hardware at the customer site. This resolution corresponds to RGB video digitized at approximately 6 MHz and at 6 bits per color. RGB pixel values would be packed in 9-bit words and transmitted using the 9-bit TAXI transmission mode at twice the sample rate.

The system described here would require two fiber pairs or an advanced TAXI with a higher transmission rate in order to handle full-bandwidth, i.e., 640(H) x 480(V) x 18-bit, video without compression. The compression/decompression mechanism dominates the cost of a video codec. Since its cost can be shared, performing compression within the video codec, rather than at the customer site, is desirable.

Excluding the video camera and monitor, the customer premise equipment cost for this implementation is estimated to be approximately \$2000 when manufactured in low volumes. Loop-through to local users would be supported via the digital switch and would provide near full-bandwidth video to local users. Synchronization problems would be minimized via the use of frame buffers. Digital transmission via TAXI would also minimize noise problems.

The resampling of video information required by this implementation could result in aliasing problems. Resampling is necessitated by the fact that off-the-shelf video codecs use standard base-band video as input and output. Although it might be possible to modify video codecs to accept and produce digital video, the cost would be prohibitive in a low-volume setting.

The use of multi-mode fiber would limit the transmission distance available with this implementation, without amplification, to approximately three miles. Upgrading the system to single-mode electronics, which would eliminate this limitation, would add approximately \$2000 per node to the system cost.

#### 4 High-Volume Option: Digital Transmission Via TAXI with Modified Codecs

This implementation uses two TAXI transmitter/receiver pairs to connect a video codec front end on the customer site with modified codecs at a telephone company vault or central office via a digital switch. In this high volume implementation, single-mode fiber would be used to connect each TAXI transmitter subsystem with the corresponding TAXI receiver subsystem. A video codec back end would be used at the customer site to regenerate received video. The availability of standard video codec front and back ends at the customer site would eliminate the need for special cameras and/or monitors, and standard NTSC units could be used.

The video codecs connected to the digital switch would not contain video digitization circuitry, but would obtain this information via the digital TAXI link. In addition, the video information generated by the modified codecs would sent via a TAXI link to the video regeneration circuitry, or codec back end, located on the customer premise.

Excluding the video camera and monitor, the customer premise equipment cost for this implementation is estimated to be approximately \$2000 when manufactured in high volumes. The system would handle full-bandwidth color (NTSC) and black-and-white (RS-170) video, and loop-through to local users would be supported via the digital switch and a false local codec. Local loop-through would provide near full-bandwidth video to local users. Synchronization problems would be minimized via the use of modified video codecs.

The system described here could be provided, in a high-volume situation, for about the same cost as the multi-mode TAXI system described previously. Single-mode fiber would support long distance transmission without amplification. The use of non-standard codecs would, however, require interaction with a codec vendor or the development of equivalent technology. The design of modified video codecs would be costly and would only be justified if high-volume usage were anticipated.

#### 5 Discussion/Conclusions

The video link design study has investigated the architectural possibilities associated with a fiber optic video link system capable of providing video codec service to commercial and/or residential telephone customers. Two low volume solutions were identified: 1) the use of off-the-shelf RCA Fiber Optic Link Video Transmitters and Receivers in conjunction with an analog switch; and 2) the

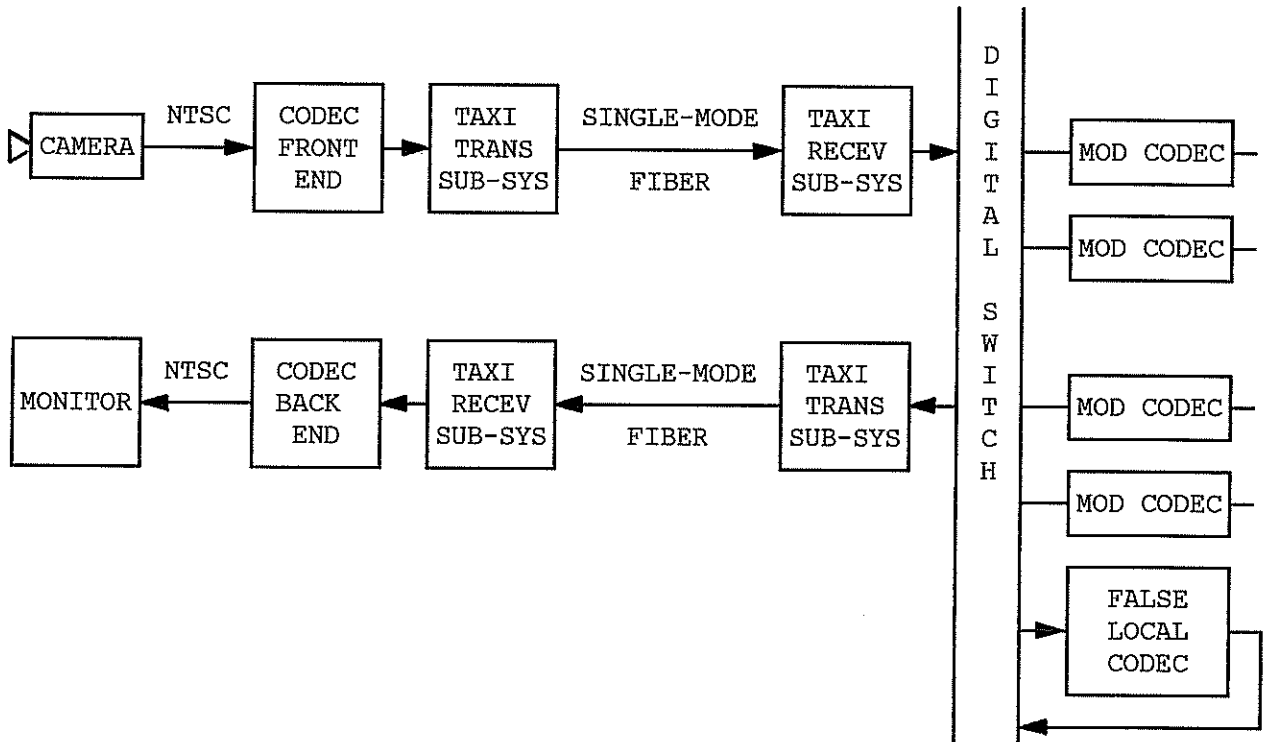

Fig. 4. High Volume Option: Digital Transmission via TAXI with Modified Codecs

use of AMD TAXI transmitters and receivers and a digital switch to provide digital video transmission via fiber optic links. When multi-mode electronics are used in conjunction with multi-mode fiber, these options provide cost effective methods for investigating the commercial viability of video codec service as described here. Each of these implementations could also be used with single-mode devices and fiber, although they would most likely be too expensive for low-volume installations.

For high-volume installations, the use of single-mode electronics and fiber with modified video codecs, as described by the third option above, can be more easily justified. The use of modified video codecs would allow the use of standard cameras and monitors. Digital transmission via TAXI would provide a cost-effective method for transmitting information between the codec front- and back-ends and the modified video codec. The modification of an available video codec would, however, be expensive. A large installation would be necessary in order to realize substantial cost savings.

#### References

- [1] RCA/Burle Closed Circuit Video Product Guide, Burle Industries, Inc., Lancaster, PA, pp. 40-41, July, 1988.
- [2] Advanced Micro Devices Am7968/Am7969 TAXIchip Integrated Circuits Data Sheet, Advanced Micro Devices, Inc., Sunnyvale, CA, pp. 1-32, January, 1989.
- [3] AT&T ODL 200 Lightwave Data Link With Flag Data Sheet, AT&T, Allentown, PA, pp. 1-8, October, 1988.
- [4] Analog Devices Hybrid RS-170 Video Digitizer Data Sheet, Analog Devices, Inc., Norwood, MA, pp. 1-8, July, 1987.