

11-5-2010

9th Annual Conference on Recent Developments in Intellectual Property Law & Policy

Marc Greenberg

Golden Gate University School of Law, mgreenberg@ggu.edu

William T. Gallagher

Golden Gate University School of Law, wgallagher@ggu.edu

Chester S. Chuang

Golden Gate University School of Law, cchuang@ggu.edu

Follow this and additional works at: <http://digitalcommons.law.ggu.edu/iplaw>



Part of the [Intellectual Property Law Commons](#)

Recommended Citation

Greenberg, Marc; Gallagher, William T.; and Chuang, Chester S., "9th Annual Conference on Recent Developments in Intellectual Property Law & Policy" (2010). *Intellectual Property Law*. Paper 2.

<http://digitalcommons.law.ggu.edu/iplaw/2>

This Conference Proceeding is brought to you for free and open access by the Centers & Programs at GGU Law Digital Commons. It has been accepted for inclusion in Intellectual Property Law by an authorized administrator of GGU Law Digital Commons. For more information, please contact jfischer@ggu.edu.



THE INTELLECTUAL PROPERTY LAW CENTER

Presents
The 9th Annual Conference on
Recent Developments in
Intellectual Property Law & Policy

November 5th, 2010

GOLDEN GATE UNIVERSITY

School of Law

With generous support by

townsend.

The 9th Annual Conference on Recent Developments in Intellectual Property Law and Policy

Golden Gate University School of Law
San Francisco, CA

Friday November 5th, 2010

© All rights reserved (except as to previously printed materials)

Speaker Agenda

9:00am - 10:00am	Patent Law Update Robert B. Morrill <i>Sidley Austin LLP</i> Justin T. Beck <i>Beck, Ross, Bismonte & Finley LLP</i>
10:00am - 11:00am	iP: YouTube, MySpace, Our Culture Madhavi Sunder <i>Professor of Law, UC Davis School of Law</i>
11:00am - 11:15am	Break
11:15am - 12:30pm	Panel Discussion: Online Gaming Law Neil Smith <i>Ropers, Majeski, Kohn, Bentley PC</i> Janna Smith <i>NAMCO BANDAI Games America, Inc.</i> Jed Ritchey <i>Zynga</i> Pam Ostroff <i>Electronic Arts</i> Stephen Rubin <i>www.stephenrubin.com</i>
12:30pm - 1:30pm	Lunch SBA Lounge
1:30pm - 2:30pm	Ethics in IP Practice John Steele <i>www.johnsteelelaw.com</i>
2:30pm - 3:30pm	Tailoring the Patent System to Promote Innovation Dan L. Burk <i>Professor of Law, UC Irvine School of Law</i>
3:30pm - 3:45pm	Break
3:45pm - 4:45pm	Trademark Law Update Anne Haring Hocking <i>Hocking, Haring & Smith LLP</i> Richard L. Kirkpatrick <i>Pillsbury Winthrop Shaw Pittman LLP</i>
4:45pm - 5:00pm	Concluding Remarks Marc Greenberg & William Gallagher <i>Golden Gate University School of Law</i>

TO: IP Law Conference Participants
FROM: GGU IP Law Center and IP Law Faculty
RE: Welcome!

November 5th, 2010

Welcome to the 9th Annual IP Law Conference at the Golden Gate University School of Law. This year's conference, titled Recent Developments in Intellectual Property Law and Policy, adds a new dimension to prior conferences – a focus on policy issues pertaining to IP law. We have previously limited our presentations to practice-oriented approaches, however we recognize that IP law practice is increasingly affected, in very significant ways, by the policy issues that underlie the law.

To address these policy issues, we are pleased to bring IP law professors Madhavi Sunder (U.C. Davis School of Law) and Dan Burk (U.C, Irvine School of Law) to present their cutting-edge recent scholarship on social networking sites and on the Patent system. Continuing our tradition of providing updates on recent developments in IP law, we also have panels on trademark and patent law so practitioners and students can become aware of key new developments in these critical IP fields of practice.

We are also excited to add a new subject matter to our program this year: online gaming law. Veteran IP lawyer Neil Smith has put together a panel of expert attorneys, including in-house counsel from Electronic Arts and Zynga, for what promises to be an insightful look at issues in this rapidly changing area of the law.

The IP Law Center has continued this year to bring important participants in the IP bar and academy to the University to present their views as part of our Distinguished IP Law Speaker Series. Professor Pamela Samuelson of Berkeley Law School offered a brilliant analysis of the Google Book Search Settlement in remarks she presented on October 7th, and this coming April 11th, 2011 the Center will welcome Ninth Circuit Chief Judge Alex Kozinski as our third Distinguished IP Law Speaker.

The Center's online presence continues to grow as well. Our highly praised IP Law Book Review will issue its second volume early in 2011, and Professor Greenberg's IP Buzz blog continues to address new issues and cases in IP Law. Bookmark the main site page, www.gguiplc.com to stay abreast of all of the Center's activities and to link to the review and blog.

Lastly, enjoy the conference, and let us know what you think of the program. We are always looking for ways to improve your experience, and thank you for your attendance and support of IP law at Golden Gate.

536 Mission Street
San Francisco, CA
94105-2968
Tel: 415.442.6600
Fax: 415.442.6609
www.ggu.edu/law
iplaw@ggu.edu

Sincerely,

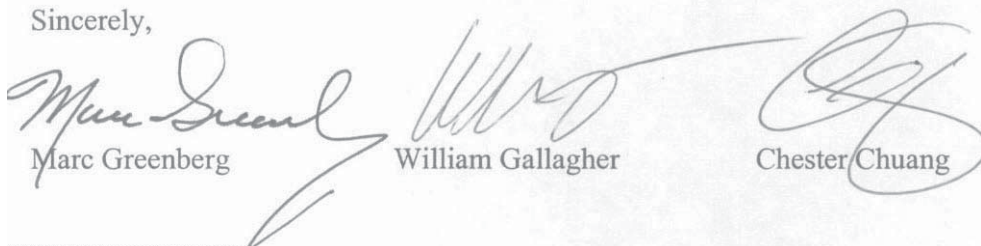

Marc Greenberg William Gallagher Chester Chuang



Marc Greenberg

Marc H. Greenberg is Professor of Law, founding Director, and currently Co-Director of the Intellectual Property Law Center and Program at Golden Gate University of Law. A member of the faculty since 2000, he teaches Intellectual Property Survey, Internet and Software Law, Intellectual Property and New Technology, and Entertainment Law in the IP curriculum. He also teaches Civil Procedure, Business Associations and related courses in the general curriculum. He is the 2010-2011 Chair of the Art Law Section of the American Association of Law Schools, and is a past co-chair of the Copyright Section of the San Francisco Intellectual Property Law

Association.

Professor Greenberg received his A.B. degree in English Literature from the University of California, Berkeley; his J.D. from the University of California, Hastings College of the Law, where he served as an articles editor of the Hastings Constitutional Law Quarterly and published the first of his scholarly works analyzing the First Amendment cases of the Supreme Court's 1978 term.

Professor Greenberg's scholarship has focused on legal issues pertaining to content on the Internet, obscenity law in online contexts, and copyright issues both in the U.S and in China. He is presently working on a series of articles focusing on comic books, graphic novels and the law. His articles have been published in the *Berkeley Technology Law Journal*, *The Syracuse Journal of Law and Technology*, *The John Marshall Review of Intellectual Property Law*, and *The Loyola Chicago University Journal of International Law*.

Before joining the GGU faculty, Professor Greenberg practiced IP, entertainment and business law, in both transactional work as well as litigation, in several firms in Northern California. He was of counsel to Chickering and Gregory in San Francisco and was a managing partner in his own firm, Nelsen and Greenberg, also in San Francisco.



William Gallagher

William Gallagher is Associate Professor and Co-Director of the IP Law Center at the Golden Gate University School of Law, where he teaches courses on intellectual property litigation, intellectual property law, torts, and legal ethics. He is also currently a Visiting Scholar at the Center for the Study of Law and Society at the UC Berkeley School of Law (2009-2010). He currently serves on the Executive Committee of the State Bar of California's IP Law Section.

Professor Gallagher previously taught as a lecturer in intellectual property law and ethics at the Santa Clara University School of Law. He received his JD from the UCLA School of Law; his Ph.D. from the University of California, Berkeley School of Law (Jurisprudence and Social Policy Program); his MA from the University of Chicago; and his BA from the University of California, Berkeley.

Professor Gallagher is the author of articles on intellectual property law and professional ethics, which have appeared in the *Santa Clara Law Review*, *Pepperdine Law Review*, *Law and Social Inquiry*, *Center for the Study of Law and Society/Jurisprudence and Social Policy Program Faculty Working Papers* (University of California, Berkeley School of Law), and the *Law and Politics Book Review*. His edited book, *International Essays in Law and Society: Intellectual Property*, was published in 2007 by Ashgate Press.

Before entering full-time academia, Professor Gallagher was a partner in the San Francisco office of Townsend and Townsend and Crew LLP, where he specialized in patent, copyright, trademark, trade secret, and related intellectual property litigation in both state and federal courts nationwide.



Chester Chaung

Chester Chuang is an associate professor at the Golden Gate University School of Law, where he teaches contracts and patent law. His research focuses on patent law.

Professor Chuang received his J.D. from the New York University School of Law and his B.S. in Pharmacy from the Ohio State University. He is the author of articles which have appeared in the *Employee Rights and Employment Policy Journal (Chicago-Kent College of Law)* and the *New York University Law Review*. His latest article, *Unjust Patents & Bargaining Breakdown: When is Declaratory Relief Needed?*, will be published by the *S.M.U. Law Review* in March 2011.

Prior to entering academia, Professor Chuang was Sr. Corporate Counsel for Electronics For Imaging, Inc., a leader in digital imaging and print management solutions for the commercial printing and enterprise markets. He also worked previously as an associate with O'Melveny & Myers and Perkins Coie, specializing in IP licensing and litigation, and served as a judicial clerk for the Hon. Sandra Brown Armstrong, U.S. District Court, N. D. Cal.



Justin T. Beck

**Partner
Beck, Ross, Bismonte
& Finley LLP**

Justin T. Beck is a partner in the firm of Beck, Ross, Bismonte & Finley LLP in San Jose California, where he specializes in intellectual property litigation. Before the founding of Beck Ross in 2006, Mr. Beck was of counsel to the firm of Mount & Stoelker P.C. and was previously a partner in the Silicon Valley firm of Skjerven Morrill LLP, where he had practiced since 1985. Mr. Beck is a 1965 graduate of Stanford University, and received his J.D. magna cum laude in 1972 from the University of San Francisco. Mr. Beck is an adjunct professor at both Golden Gate University School of Law and the University Of Oregon School Of Law teaching copyright law and patent litigation. He also writes frequently on intellectual property issues.

Patent Law Update 2010

Golden Gate University Law School
9th Annual Conference on Recent
Developments in Intellectual Property Law
November 5, 2010

Robert Morrill
Sidley Austin LLP
Justin Beck
Beck, Ross, Bismonte & Finley LLP

1

How Are These Alike?



False Marking

The Rise and *Probable* Fall of a Legal Fad

Patent Marking

- §287 – The public is given notice that an article is patented by marking with the word “patent” or “pat.” and the patent number. If there is a failure to mark, no damages shall be recovered in any action for infringement except on proof that the infringer had been put on notice.

False Marking

- §292 (a): “Whoever marks ...or uses in advertising in connection with any unpatented article . . . Any word or number importing that the same is patented for the purpose of deceiving the public . . . Shall be fined not more than **\$500 for every such offense.**”
- §292 (b): “**Any person may sue for the penalty**, in which event one-half shall go to the person suing and the other to the use of the United States.”

Qui Tam

- English common law permitted private enforcement of the King’s laws.
- Adopted by the United States in the 19th Century but fell out of use with the growth of government agencies
- § 292, originally enacted in 1842, is one of a handful of *qui tam* survivors

§292 slumbered for a century



Then Along Came:

*Forest Group, Inc.
v. Bon Tool Co.*,
590 F.3d 1295,
1303 (Fed. Cir.
Dec. 28, 2009)



What is an “offense”

- § 292’s maximum penalty is \$500 for each “offense” – but what is an offense?
- Courts generally followed the 1st Circuit in holding that a continuous series of false markings was a single offense
- In December, the Federal Circuit took a fresh look and held that each falsely marked article was a separate offense

What’s the Difference? The *Solo Cup* Example

- The trial court, applying the 1st Circuit rule, found three offenses, with a maximum penalty of **\$1500**
- Under the Federal Circuit rule
 - 20+ billion offenses
 - \$10,800,000,000,000** maximum penalty

The Federal Circuit’s Green Light

- “Forest argues that interpreting the fine of § 292 to apply on a per article basis would encourage “a new cottage industry” of false marking litigation by plaintiffs who have not suffered any direct harm. This, however, is what the clear language of the statute allows”

Forest Group, Inc. v. Bon Tool Co., 590 F.3d 1295, 1303 (Fed. Cir. Dec. 28, 2009)

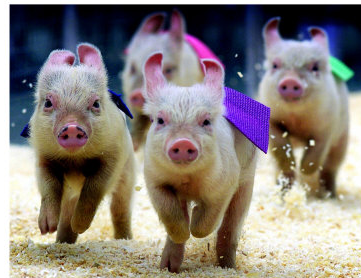

False Marking Filings

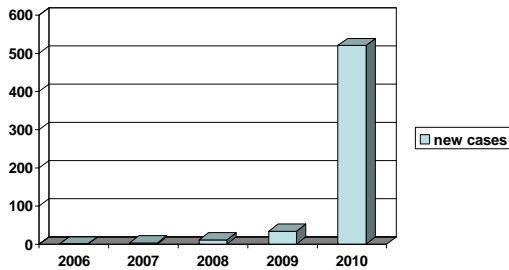

Defendants Fight Back



Constitutional Issues

- Standing
 - No individual injury
 - Assignment of sovereign claim
 - *Stauffer v. Brooks Bros. Inc.*, ___ F.3d ___ (Fed. Cir. August 31, 2010)
- “Take Care” Clause
 - Intervention by U.S. as of right

Intent

- *Clontech Laboratories Inc v. Invitrogen Corp.*, 406 F.3d 1347 (Fed. Cir. 2005) (Defendant has burden of proving it had a reasonable belief marking was proper)
- *Pequignot v. Solo Cup Company*, 608 F.3d 1356 (Fed. Cir. 2010) (Specific intent to deceive the public required; merely knowing that marking is false and public may be deceived insufficient)

Expired Patents

- Many innocent explanations:
 - Didn't know the patent expired
 - Somebody dropped the ball
 - Waiting for the tooling to wear out
- The *Brooks Brothers* hint:
 - We remand for the court to address. . . Brooks Brothers' motion to dismiss . . . “on the grounds that the complaint fails to state a plausible claim to relief because it fails to allege an ‘intent to deceive’ the public – a critical element of a section 292 claim – with sufficient specificity to meet the heightened pleading requirements for claims of fraud imposed by” Rule 9(b).

Pleadings

- Rule 8 –notice pleading
- Rule 9(b) – “In alleging fraud or mistake, a party must state with particularity the circumstances constituting fraud or mistake. Malice, intent, knowledge, and other conditions of a person's mind may be alleged generally.”

In the District Courts

- Many courts follow the *Brinkmeier* cases applying Rule 9(b) to dismiss cases absent specific facts
- Some district courts, including the Eastern District of Texas, hold 9(b) does not apply, or is satisfied by general allegations

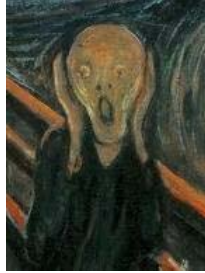

In re BP Lubricants

- Petition for Writ of Mandamus filed 9/29 after court denied motion to dismiss. Petitioner seeks to have the strict pleading requirement adopted
- The United States has filed an *amicus* brief supporting the petitioner

Legislation

- S 515 pending in Senate amended to limit § 292(b) actions to recovery of competitive injury
- HR 4954 would limit actions to recovery for competitive injury to the plaintiff
- HR 6352 would limit recoveries for all offenses in the aggregate to \$500 and limit standing

Looking Ahead

- *BP Lubricants* will likely tighten the pleading requirements and make it difficult for plaintiffs to properly plead a claim for relief.
- Patent reform, whenever it is enacted, will amend § 292(b), limiting private actions to recovery for competitive injury

False Marking Suits – The End?

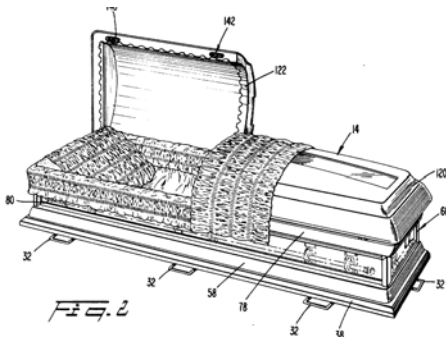



Robert Morrill

**Partner
Sidley Austin LLP**

Robert Morrill is a partner in Sidley's Palo Alto office, where he specializes in intellectual property and business litigation. He has resolved or tried patent, trade secret, trademark, copyright, unfair competition, wrongful termination, trade secret, license and contract disputes for clients in many industries, including semiconductors, semiconductor manufacturing equipment, computer hardware and software, telecommunications, electronics, medical devices, gaming and pharmaceuticals. His practice includes cases before the United States International Trade Commission, as well as in the Federal and State courts and in arbitration.

Mr. Morrill also has extensive experience as a neutral arbitrator or mediator, including international arbitration in the ICC International Court of Arbitration and the International Center for Dispute Resolution. He has been appointed Special Master by the U.S. District Court for the Northern District of California and the Santa Clara County Superior Court, and he serves as an Early Neutral Evaluator and Mediator for the U.S. District Court. Before joining Sidley in 2003, Mr. Morrill was a founding partner at the law firm of Skjerven Morrill LLP.

THE FEDERAL CIRCUIT TAKES ON PATENT DAMAGES REFORM



Players in the Damages Debate

- Patent damages is the biggest obstacle to patent reform
- Electronics/internet (Coalition for Patent Reform)
 - Google, Apple and others who get sued over patents – 730 suits 1996-2008
 - Limit damages from “patent extortion”
- Big pharma, universities (and trolls)
 - Patent licensors
 - Keep things the way they are
 - The Coalition is “aiming to infringe”

2

Damages Reform in Congress

- 2007 Draft: Judge conducts an analysis to ensure that a reasonable royalty is applied only to the portion of the infringing product properly attributable to the claimed invention
- Current Draft: District Judges act as “gatekeepers” who identify the “methodologies and factors that are relevant to the determination of damages” and allow the jury to “consider only those methodologies and factors relevant to making such determination.”

3

Damages Reform in the Federal Circuit

- Former Chief Judge Michel: excessive damages are “mythology” not reflected in the case law
- Current law is flexible, allows district courts to consider many factors. Proposed reform is inflexible and overly constrains fact-finder
- The Federal Circuit has set about to prove that it is up to patent damages reform

4

What's at Stake?



- \$357M: *Lucent v. Gateway* (2009)
- \$184M: *Cornell v. Hewlett-Packard* (2009)
- \$240M: *i4i v. Microsoft* (2009)

5

The Measure of Damages

- “damages adequate to compensate for the infringement, but in no event less than a reasonable royalty “ 35 U.S.C. § 284
- Two types of patent damages:
 - Lost profits – usually lost sales
 - Reasonable royalty
- For a reasonable royalty,
 - What is the royalty *base*?
 - What is the royalty *rate*?
 - $\text{Royalty base} \times \text{royalty rate} = \text{damage award}$

6

Experts Long Ruled the Reasonable Royalty Roost

- Few cases on reasonable royalty until 2009
- Wide latitude for experts
 - Hypothetical license negotiation using the Georgia Pacific
 - Royalty rate often set by “Rule of Thumb” that the licensee would be willing to pay 25% of its profits
 - All industry licenses were “comparable”
 - Royalty base was often the end product under the entire market value rule

7

The Entire Market Value Rule

A reasonable royalty may be based on the entire value of an infringing product which incorporates the patented feature, *if* the invention is the basis for consumer demand

8

Lucent v. Gateway

- “Date-Picker” feature in Microsoft Outlook
- Lucent’s expert used:
 - Entire Market Value Rule
 - Comparable licenses, both lump-sum and running royalty
- Lucent sought \$561M in running royalties (8%)
- Microsoft suggested a lump sum of \$6.5M
- Jury awarded a \$357M lump sum
- Damages reversed, “no substantial evidence”

9

Lucent v. Gateway EMVR/Royalty Base

- “lack of evidence demonstrating the patented method of the Day patent as the basis—or even a substantial basis—of the consumer demand for Outlook”
- “the infringing use of the date-picker tool on Outlook is but a very small component of a much larger software program”
- “no evidence that anybody anywhere at any time ever bought Outlook . . . because it had a date picker”
- “the invention is not the reason consumers purchase Outlook”
- “Date-picker” was “but a tiny feature,” one of “hundreds if not thousands or even more features” in Outlook

10

Lucent v. Gateway Royalty Rate

- Actual license rates for similar technology can be probative of a “reasonable royalty”
- Lucent’s licenses?
 - Some “comparable” licenses were cross-licenses or licenses to entire portfolios with no shown relevance
 - “Doubtful the technology is in any way similar”
 - No showing of how to calculate percentage royalty using lump sum or “dollars per unit” licenses

11

Lucent v. Gateway Relationship of Base and Rate

- The value of the entire product may be used for a royalty base, particularly where there is no market for the infringing component, if the royalty rate adjusts for the proportion of the base represented by the infringing feature
- “Real world” licenses often do this

Cornell v. Hewlett-Packard

- Invention: A component of the instruction recorder buffer in the processor (CPU)
 - Instruction recorder buffer
 - Is part of
 - CPU chip
 - Which goes into
 - CPU module
 - Which goes into
 - CPU “bricks”
 - Which go into
 - HP servers and workstations
- Smallest salable unit was the CPU

Cornell v. Hewlett-Packard Cornell’s First Damages Theory

- Damages base is all HP sales of servers and workstations, using the entire market value rule
- Judge Rader:
 - Interrupted the trial to conduct a *Daubert* hearing
 - “The Federal Circuit has limited application of the Entire Market Value Rule to instances where “the patent-related feature is the basis for customer demand” for an accused product that nevertheless contains other features.”
 - “Cornell did not . . . Attempt in any way to link consumer demand for servers and workstations to the claimed invention.”

Cornell v. Hewlett-Packard Cornell’s Second Damages Theory

- Damages based on sales of CPU bricks, using the entire market value rule
- Jury: 0.8% royalty on \$23B sales = \$184M
- HP moved for JMOL or remittitur

Cornell v. Hewlett-Packard Entire Market Value Thrown Out

- No evidence that the patented feature drove customer demand for bricks (or for HP products)
- No evidence connecting customer demand for computer performance to the claimed invention
- Cornell’s expert “included earnings from the sale of many components of Hewlett-Packard’s products that are not covered at all by the claimed invention.”
- Damages reduced to \$53M based on CPU sales

i4i v. Microsoft

- XML editor in Microsoft Word
- 25% “rule of thumb” and Microsoft’s 76.6 profit margin were applied to a \$499 “benchmark” alternative product, and adjusted upward with *G-P* factors to a royalty of \$98 per unit
- Possible to buy a copy of Microsoft Word for \$98
- Jury awarded \$200M plus \$40M in enhanced damages

i4i v. Microsoft Continued

- Questioning during oral argument:
 - The court did not like the 25% rule
 - The court did not like the failure to apportion the value of the patented feature relative to the price of the product
- Affirmed: Sufficiency of the evidence not challenged
 - “had Microsoft filed a pre-verdict JMOL, it is true that the outcome might have been different”

Lessons

- Federal Circuit is finally paying attention to reasonable royalty damages
- “Anything goes” days of expert witnesses are over
- Evidence will be rigorously reviewed by appellate *and* trial courts
- Comparable licenses must *really* be comparable
 - Comparable technology
 - Comparable economic circumstances
- Licenses in settlement of litigation should be used

19

More Lessons

- The 25% rule has little or no support at the Federal Circuit
- Reasonable royalty analysis must set the value of the patented feature relative to the entire product
- Evidence of *customer* demand for patented feature is necessary for the entire market value rule
 - “Demand curves”
 - “Customer surveys”
- Defendant should *always* properly move for JMOL

20



Madhavi Sunder

**Professor of Law
UC Davis School of Law**

Education

- B.A., Social Studies, Harvard University 1992
- J.D., Stanford University 1997

Professor Sunder is a 2006 Carnegie Scholar and a leading scholar in the legal regulation of culture. Her work traverses numerous legal fields, from intellectual property and cultural property to human rights law and the First Amendment. She asks how age-old legal doctrines impede, rather than facilitate, change and modernity within traditional cultures. Adopting an interdisciplinary method, she argues that cultural studies and globalization studies can help us to modernize antiquated laws for the 21st century. Her recent publications include: "IP3," *Stanford Law Review* (2006), "The Invention of Traditional Knowledge," *Law & Contemporary Problems* (2007); "The Romance of the Public Domain," *California Law Review* (2004); "Piercing the Veil," *Yale Law Journal* (2003); and "Cultural Dissent," *Stanford Law Review* (2001). She has authored numerous comments and chapters in books and is the editor of *Gender and Feminist Theory in Law and Society* (2006). She is a contributor to Findlaw.com.

Special Interests

Intellectual Property (Including International Intellectual Property), Law And Cultural Studies, Cyberlaw, Women's Rights

Selected Career Highlights

- Carnegie Corporation Scholar 2006-2008
- "IP3" paper selected for Stanford/Yale Jr. Faculty Forum (2006)
- Honored as one of four "top young IP scholars" (by Lawrence Lessig, Professor of Law, Stanford Law School, 2006)

Selected Publications

- IP3, 59 *Stan. L. Rev.* 257 (2006)
- Piercing the Veil, 112 *YALE L. J.* 1399 (2003). Excerpted in *JUST ADVOCACY: WOMEN'S HUMAN RIGHTS, TRANSNATIONAL FEMINISM, AND THE POLITICS OF REPRESENTATION* (Wendy Hesford & Wendy Kozol, eds.) (2004).
- Cultural Dissent, 54 *STAN. L. REV.* 495 (2001).
- Everyone's a Superhero: A Cultural Theory of Mary Sue Fan Fiction as Fair Use, 95 *Cal. L. Rev.* (forthcoming 2007) (with Anupam Chander)

CURRICULUM VITAE

NEIL ARTHUR SMITH
Ropers, Majeski, Kohn & Bentley
201 Spear Street, Suite 1000
San Francisco, CA 94105-1667
Tel.: 408/918-4523 Fax: 408/918-4501
nsmith@rmkb.com

EMPLOYMENT EXPERIENCE:

Private Law Practice: Partner, Ropers Majeski Kohn & Bentley in San Francisco and San Jose, California, specializing in patent, trademark, trade secret, unfair competition and copyright matters; private mediation for intellectual property cases (2010-).

Private Law Practice: Partner in law firms in San Francisco, California, specializing in patent, trademark, trade secret, unfair competition and copyright matters; private mediation for intellectual property cases (2001-2010).

Private Law Practice: Partner, Limbach & Limbach L.L.P., San Francisco, California, specializing in patent, trademark, unfair competition, trade secret, and copyright matters (1974-2000).

Law Clerk: To Judge Giles S. Rich, United States Court of Customs and Patent Appeals in Washington, D.C. (Predecessor to the Court of Appeals for the Federal Circuit) (1972-1974).

Patent Attorney: United States Atomic Energy Commission, Washington, D.C. (1969-1972).

EDUCATION:

L.L.M. in Patent and Trade Regulation Law, George Washington Law School, 1973.

J.D. Columbia Law School, Columbia University, 1969. Stone Scholar.

B.S. in Mechanical Engineering, Columbia School of Engineering and Applied Science, Columbia University, 1966. Tau Beta Pi.

B.A. in Physical Sciences, Columbia College, Columbia University, 1965.

PUBLICATIONS:

Author of numerous articles on patent, trademark, and copyright law, trade secret protection, Internet law issues, anticounterfeiting remedies and gray market subjects, including: "Complex Patent Suits: The Use of Special Masters for Claim Construction" 2, Landslide 1, Oct. 2009 (American Bar Association), "The Interface Between Antitrust Law and Trade Secret Law," 3, The Corporate Analyst, No. 1, p. 134, Nov. 1990, "Fraud Upon the Patent Office as a Violation of the Sherman Antitrust Law," 53 Journal of the Patent Office Society 337, 423; "The Collateral Estoppel Effect of a Prior Judgment of Patent Invalidity: Blonder-Tongue Revisited," 55 Journal of the Patent Office Society 285, 363, 436, 1973; "Obtaining Early and Effective Relief Against Trademark Counterfeiting," 10 COMM/ENT, Hastings College of the Law, No. 4, p. 1049, Summer 1988; author of Chapter 71 entitled "Discovery in Trademark Cases in the Courts and Trademark Trial and Appeal Board for Intellectual Property Counseling and Litigation; author of Chapter 10 entitled "Trademarks, Creation Protection and Valuation," for The Trademark Law of the United States; author of quarterly column entitled "Ninth Circuit Report," for "New Matter," a Publication of the State Bar of California Intellectual Property Section and, in ABA Litigation Section IP Division Newsletter; contributing author to book, Risky Business: Protect Your Business from Being Stalked, Conned, or Blackmailed on the Web, by Daniel S. Janal, John Wiley Sons, Inc., 1998. Author,

Chapter "New Strategies for Infringement Litigation" Recent Trends in Patent Infringement Lawsuits. Aspotore/Thomson, 2010; Editorial Advisory Board, IP Litigator, Editorial Advisory Board, Internet Law & Business.

LECTURES AND COURSES:

Speaker on several trademark, patent and unfair competition, and alternative dispute resolution subjects to various bar associations, law schools, and IP law organizations, including San Francisco Patent Law Association, San Francisco Barristers Club, the California, Colorado, Washington State, Ohio, Oregon and Utah State Bar Associations; Intellectual Property Associations in Los Angeles, San Diego, Pacific Northwest; American Patent Institute, Patent Bar Review course; Practising Law Institute (PLI), American Bar Association, Litigation Section, Science & Technology and IP Law Sections, Copyright Society, United States Trademark Association, American Intellectual Property Law Association, International Trademark Association, Computer Law Association, Stanford Law School, Hastings Law School, Golden Gate Law School, University of California Law School, Santa Clara Law School, speaker on Digital Technology and The Internet Conferences, American Conference Inst.; Testified on the Draft Report of the United States Working Group on Intellectual Property Rights of the National Information Infrastructure Task Force, and the World Intellectual Property Organization; U.S. Reporter for ALAI on the subject of technical devices for the protection of copyrights in digital works.

BAR ASSOCIATION ACTIVITIES AND RELATED OFFICES HELD:

Served in the following capacities: President, San Francisco Patent and Trademark Law Association; American Intellectual Property Law Association: Board of Directors, Trademark and Committee Chairman, Licensing, Federal Courts Committee Chairman; American Bar Association, PTC Section: Chairman of Divisions (Trademarks), and (Other IP Committees), Chairman Trademark and Trade Name, Copyright, Trade Secret Committees and Trademark Office Affairs Committee, PTC Section delegate to ABA RICO Committee; Member, Advisory Board of the Patent, Trademark and Copyright Journal of the Bureau of National Affairs; State Bar of California: Executive Committee Member, Patent and Trademark Section, International Law Section, Officer, and State Bar Conference of Delegates; Former member, U.S. Dept. of Commerce Public Advisory Committee on Trademark Office Affairs; Trustee, United States Copyright Society; Pres. Bay Area Intellectual Property Chapter, American Inns of Court. Appointed Intellectual Property Research Specialist, California Blue Ribbon Task Force on Nanotechnology.

AWARDS AND RECOGNITION:

- Named in Who's Who Legal: The International Who's Who of Business Lawyers, 2005
- Named *U.S. Litigator of the Year*, "Managing Intellectual Property," 1999
- Named for over ten years in "The Best Lawyers In America" for Intellectual Property
- Named in "Guide to the World's Leading Experts in Trademark Law;" "Guide to World's Leading Experts in Patent Law;" "Who's Who of Internet and Electronic Commerce Lawyers;" "The International Who's Who of Business Lawyers" and the "International Who's Who of Trademark Lawyers" and "Chambers USA," "America's Leading Lawyers for Business"
- Named a *SuperLawyer* in "Northern California Super Lawyers Magazine"
- First Recipient of U.S. Patent and Trademark Office's Joseph Rossman Award



New Matter

Official Publication of the Intellectual Property Law Section of the State Bar of California

Ninth Circuit Report



Neil A. Smith
Ropers Majeski Kohn & Bentley

COPYRIGHT FIRST SALE DOCTRINE DOES NOT APPLY TO GOODS WHICH ARE PURCHASED OUTSIDE THE UNITED STATES AND IMPORTED INTO THE UNITED STATES

***Omega S.A., v. Costco Wholesale Corporation* ___ F.3d ___ (9th Cir. September 3, 2008)**

OMEGA MANUFACTURES WATCHES in Switzerland and sells them throughout the world and in the United States. Each watch has on the back an “Omega Globe Design” which has been copyrighted in the United States, no doubt with the view to use the copyright to keep out foreign goods such as those at issue here.

Discount store Costco purchases watches on the “gray market” from ENE Limited, a New York company, which purchased the watches from authorized Omega watch dealers overseas. Although Omega authorized the initial foreign sale of the watches, it did

not authorize the importation of the watches into the United States or the sales made by Costco, and filed this copyright infringement in the Central District of California. The parties filed cross motions for summary judgment, with Costco arguing that the “first sale doctrine” under 17 U.S.C. § 109(a) applied to provide a defense to any copyright infringement.

The First Sale Doctrine

The first sale doctrine of Copyright Act § 109(a) provides: “Notwithstanding the provisions of section 106(3), the owner of a particular copy...lawfully made under this title, or any person authorized by such owner, is entitled, without the authority of the copyright owner, to sell or otherwise dispose of the possession of that copy...”

Section 602(a) of the Copyright Act prevents importation of copies of copyrighted works into the United States, without the authority of the owner of copyright: “Importation into the United States, without the authority of the owner of copyright under this title, of copies...of a work that have been acquired outside the United States is an infringement of the exclusive right to distribute copies...under section 106, actionable under section 501.” Further, section 106(3) of the Copyright Act gives a copyright owner control of distribution. It states: “Subject to sections 107 through 122, the owner of copyright under this title has the exclusive rights...to distribute copies...of the copyrighted work to the public by sale or other transfer of ownership, or by rental, lease, or lending.” The question here is the interplay between the three sections, the first sale doctrine, the exclusive right to distribute,

and the right to prevent importation, which rightfully belong to the copyright owner.

The District Court granted summary judgment to Costco applying the first sale doctrine.

In its 1998 decision *Quality King Distributors, Inc. v. Lanza Research International, Inc.*,¹ the Supreme Court held the first sale doctrine to provide a defense allowing a defendant to sell copyrighted goods which had been manufactured in the United States, shipped outside the United States, and then ultimately imported back and sold into the United States without the consent of the copyright owner. In this case, the Omega watches were actually manufactured and obtained abroad from an authorized foreign distributor, then brought in through importation into the U.S. by ESS, and then sold here by Costco.

The Court noted that before *Quality King* was decided by the Supreme Court, Ninth Circuit precedent was clear that the first sale provision § 109(a) provided no defense against a claim of infringement for importation of goods which had been made outside the United States, unless the goods had already been first sold in the United States with the permission of the copyright owner.

The defendant, Costco had argued, and the District court had held, that prior Ninth Circuit decisions had been implicitly overruled by the *Quality King* decision of the Supreme Court. For example, the Ninth Circuit had previously held in *BMG Music v. Perez*,² that the first sale doctrine provided no defense against a claim of unlawful importation under 602(a) against foreign-manufactured imported goods. As the court there said, the words “lawfully made under this title” in

§ 109(a) “grant first sale protection only to copies legally made and sold in the United States,” and the copies at issue there were made and first sold abroad. The Ninth Circuit in *Omega* noted that the rationale for this interpretation was twofold: First, “a contrary interpretation would impermissibly extend the Copyright Act extraterritorially, [and] second, the application of § 109(a) after foreign sales would ‘render § 602 virtually meaningless’... because importation is almost always preceded by at least one lawful foreign sale that will have exhausted the distribution right on which § 602 is premised.

Another prior case, *Denbicare U.S.A. Inc. v. Toys “R” Us, Inc.*,³ involved copies made in Hong Kong and voluntarily sold in the United States by the US Copyright owner, applied the first sale exception to infringement, because the goods imported by third parties into the United States prior to the defendants purchase and resale of them, although foreign made, had been voluntarily sold within the United States. The U.S. sale had “exhausted the exclusive rights of distribution.”

With this as a background, the Ninth Circuit considered the effect of the Supreme Court’s decision in *Quality King*, and held that the *Quality King* decision did not overrule such cases as *BMG Music* and *Denbicare*, since the goods in *Quality King* had been manufactured inside the United States. Justice Ginsburg, in her concurring opinion in *Quality King* specifically recognized that *Quality King* involved only domestically manufactured copies and, as she noted, “the Court did not address the effect of § 109(a) on claims involving unauthorized importation of copies made abroad. We do not today resolve cases in which the allegedly infringing imports were manufactured abroad.”

Since the *Omega* watches sold by Costco were manufactured abroad and

never sold in the United States, the court held the application of the first sale doctrine inapplicable, and thus that the decision in *Quality King* had not changed the rule.

The Ninth Circuit wrestled with the question whether the reasoning of *Quality King*, that applied § 109 to foreign-made goods, would violate the presumption against the extraterritorial application of U.S. law, and should change the result, and concluded that it did not. The court noted that in the *Quality King* decision’s only direct language on the issue was Judge Ginsburg’s concurring opinion, citing a copyright treatise for the proposition that “lawfully made under this title” means “lawfully made in the United States.”

The Court concluded that its general rule that § 109(a) refers “only to copies legally made...in the United States,” is not clearly irreconcilable with *Quality King*, and, therefore, remains binding precedent. Under this rule, the first sale doctrine is unavailable as a defense to the claims under §§ 106(3) and 602(a) because there is no genuine dispute that *Omega* manufactured the watches bearing the copyrighted Omega Globe Design in Switzerland.

Critics of the Ninth Circuit decision in *Omega* have suggested that applying the first sale doctrine to copyrighted goods manufactured in the United States, exported, and then imported into the United States, would encourage trademark owners concerned about “gray market goods” or “parallel imports,” to shift their manufacturing sources outside the United States. While this may be the result, the decision falls naturally from the law in the Ninth Circuit, not overruled by *Quality King*, and, time will tell whether this interpretation of the law will cause any shifts in manufacturing outside the United States. ■

Endnotes

1. *Quality King Distributors, Inc. v. Lanza Research International, Inc.*, 523 U.S. 135 (1998).
2. *BMG Music v. Perez*, 952 F.2d 318 (9th Cir. 1991).
3. *Denbicare U.S.A. Inc. v. Toys “R” Us, Inc.*, 84 F.3d 1143 (9th Cir. 1996). The author was counsel to the defendant Toys “R” Us, Inc. in this case.

— :: —

VIDEO GAME DEPICTION OF LOS ANGELES STRIP CLUB IS NOT INFRINGEMENT AND IS PROTECTED UNDER THE FIRST AMENDMENT.

ESS Entertainment 2000, Inc. d/ b/a Playpen v. Rock Star Video, Inc. et al. ___ F.3d ___ November 5, 2008

IN THIS INTERESTING CASE the Ninth Circuit considers trademark infringement and unfair competition within the content of a video game.

Rock Star Games, Inc., manufactures the Grand Theft Auto series of video games, which includes Grant Theft Auto: San Andreas. The series is known for an irreverent and sometimes crass brand of humor, gratuitous violence and sex, and overall seediness. The San Andreas game allows a player to experience a version of West Coast “gangster” culture, taking place in West Coast cities, with Los Santos, one of the cities, mimicking the look and feel of actual Los Angeles neighborhoods. Los Santos is populated with virtual liquor stores, ammunition dealers, casinos, pawnshops, tattoo parlors, bars, and strip clubs.

The artist who designed the video game visited Los Angeles neighborhoods, taking pictures, including a picture of a Los Angeles strip club occupied by plaintiff ESS Entertainment. This strip club features females dancing

nude, and is named the “Play Pen.” ESS (“Play Pen”) filed a suit against Rock Star for trade dress infringement and unfair competition under Section 43 of the Lanham Act, 15 U.S.C. § 1125(a) and trademark infringement and unfair competition under California law. ESS complains that Rock Star has used Play Pen’s logo and trade dress in its video game visual of its “Pig Pen bar,” and used Play Pen’s distinctive logo and trade dress without authorization, creating a likelihood of confusion among consumers as to whether ESS or its “Play Pen” bar has endorsed, or is associated with, the video game.

In the Los Angeles district court Rock Star moved for and was granted summary judgment on all claims. It argued the affirmative defense that it was making nominative fair use of a visual display of the “Play Pen,” and that, in any event, the First Amendment protected it against liability. It also argued that its use of ESS’s intellectual property did not infringe, since its video game usage did not create any likelihood of confusion.

While rejecting the defense of nominative fair use, the district court granted summary judgment based on the First Amendment defense, and found it unnecessary to address the trademark infringement claims directly.

This Is Not Nominative Fair Use

Nominative Fair Use is the fair use scenario when the accused infringer uses “the trade mark term to describe not its own product but the plaintiff’s.”¹ The doctrine protects those who deliberately use another’s trademark or trade dress for the purposes of comparison, criticism or point of reference. The Ninth Circuit looked at the video game and its purpose, and concluded that the use of the video game was not nominative fair use. First, the video game’s use of “Pig Pen” was not “identical to the

plaintiff’s mark.” Rock Star had “testified the goal in designing the Pig Pen was...not to comment on Play Pen *per se*.” Since Rock Star did not use the Pig Pen logo to describe the Play Pen Strip Club, the Ninth Circuit noted that the district court correctly held that the nominative fair use defense did not apply. The nominative fair use defense is for a defendant’s use of the plaintiff’s trademark to describe the plaintiff or its goods or services; this was not the case here. Rock Star wanted only a Los Angeles genre, seedy neighborhood and a strip club, but was not seeking to imitate the Play Pen.

Rock Star’s second defense was the First Amendment. As the court noted, the First Amendment is appropriate as a defense to an infringement claim under the Lanham Act “to apply to artistic works *only* where the public interest in avoiding consumer confusion *outweighs* the public interest in free expression.” The Court cited its decision in *Mattel Inc. v. Walking Mountain Prods.*,² where an artist was permitted to use Mattel’s Barbie Dolls in his artwork.

In order for there to be a First Amendment defense, two findings are necessary: First, an artistic work’s use of a trademark that otherwise would violate the Lanham Act is not actionable “unless the [use of the mark] has no artistic relevance to the underlying work whatsoever, or, if it has some artistic relevance, unless [it] explicitly misleads as to the source or the content of the work.” The court noted initially that although this test traditionally applies to uses of a trademark in the title of an artistic work, it found no principled reason why it ought not to apply equally to the use of a trademark in the body of a work.

Although ESS acknowledged that the game was artistic and that the test applied, it argued both that the incorporation of the Pig Pen bar into the

game had no artistic relevance and that its use of it was not explicitly misleading. First ESS observed that the game was not “about” ESS’s Play Pen Club the way the artwork was about the Barbie doll in the *Mattel* case, and secondly that unlike the *Barbie* case, where the trademark, Barbie Doll, was a cultural icon, ESS’s Play Pen was hardly a cultural icon.

The Ninth Circuit analyzed the law in terms of its own case, *Mattel v. MCA Records, Inc.*,³ another Barbie Doll case where Mattel had sued a record company with a song called “Barbie Girl” which was a commentary about Barbie and the values she supposedly represented. The court in this *Mattel* case had applied the First Amendment test to hold that it protected the record company, noting that the accused song was about the Barbie doll.

ESS agreed that in the *Mattel* case the only indication that Mattel might be associated with the song was the use of “Barbie” in the title. The Ninth Circuit noted that ESS’s objections, though factually accurate, missed the point of the rule. Under the *Barbie* song case and others that followed it “only the use of a trademark with ‘no artistic relevance to the underlying work whatsoever’ does not merit First Amendment protection.” In other words, as the court noted, “the level of relevance merely must be above zero.” The court noted that in this case, while it was true that the game was not about the Play Pen the way the Barbie Girl song was about the Barbie doll, given the low threshold of relevance the game must surmount, this fact would hardly be dispositive.

Secondly the court also noted it was also true that the Play Pen bar had “little cultural significance, but that the same could be said about most of the individual establishments in East L.A.; its distinctiveness lies in its “look and feel,” not in particular destinations. As the

court noted, that neighborhood with all its seedy characteristics was relevant to Rock Star's artistic goal, which was to develop a cartoon-style parody of East Los Angeles. The court found that possibly the only way, or at least certainly a reasonable way, to do this would be to recreate a critical mass of the businesses and buildings there, as the game did. As such the court concluded that to include a strip club that is similar in "look and feel" to the Play Pen strip club does indeed have at least "some artistic relevance," so as to support the application of the First Amendment here.

Thus the First Amendment applied as a defense to infringement and unfair competition, since the video game was an artistic work, where the public interest in avoiding customer confusion did not outweigh the public interest in free expression. The use of the image had artistic relevance to the underlying work, and did not explicitly mislead customers as to the source or content of the work.

As to confusion, the Ninth Circuit noted that while the purpose of the Lanham Act was to avoid confusion in the marketplace, the relevant question here was whether the game would confuse its players into thinking that the Play Pen was somehow behind the Pig Pen, or that it sponsors or authorizes the video games. In other words the mere use of a trademark alone would not suffice to make such use explicitly misleading.

The court analyzed the two bars and uses, and found that while the San Andreas Game, and the Play Pen strip club both "offer a form of low brow entertainment," that besides this general similarity, they have nothing in common. Video games and strip clubs do not as the court noted "go together like a horse and carriage or, perish the thought, love and marriage." Nothing would indicate that the buying public

could reasonably have believed that ESS produced the video or, that Rock Star operated a strip club. The court found it farfetched that someone playing the game would think that ESS had provided any expertise support or unique strip club knowledge it possesses to the production of the game. After all this strip club was only a backdrop within the game and whatever one can do at the Pig Pen, the video game seemed quite incidental to the court to the overall story of the game. The court concluded the reasonable consumer would not think that a company that owns one strip club in East Los Angeles, which was not well known to the public, also produces a technologically sophisticated video game like San Andreas.

One has to believe that Judge O'Scannlain must have enjoyed writing this opinion. As he noted "undeterred, ESS also argues that because players are free to ignore the storyline and within the video game spend as much time as they want at the Pig Pen, the Pig Pen can be considered to be a significant part of the game, thus leading to confusion." The court found this argument to be farfetched, but it certainly allows one to raise such issues within a virtual world of a video game. Judge O'Scannlain answered this argument with the analogy to Dodger Stadium. As he said "fans can spend all nine innings of a baseball game at the hot-dog stand; that hardly makes Dodger Stadium a butcher's shop." As he noted "the chance to attend a virtual strip club is unambiguously *not* the main selling point of the game."⁴

The virtual world creates another most interesting legal issue, but this court seems to sanction the background use of actual locations, buildings and businesses within simulated video and virtual worlds, at least where such use is either incidental or not explicitly misleading. ■

© 2008 Neil Smith.

Neil A. Smith is a partner in the Intellectual Property Practice Group of the San Francisco and San Jose offices of Ropers Majeski Kohn & Bentley

Endnotes

1. See *Playboy Enterprises, Inc. v. Welles*, 279 F.3d 796 (9th Cir. 2002).
2. *Mattel Inc. v. Walking Mountain Prods.*, 353 F.3d 792 (9th Cir. 2003).
3. *Mattel v. MCA Records, Inc.*, 296 F.3d 894 (9th Cir. 2002).
4. Author's note: Some youthful voyeurs might disagree!

FOR PUBLICATION
UNITED STATES COURT OF APPEALS
FOR THE NINTH CIRCUIT

VIDEO SOFTWARE DEALERS
ASSOCIATION; ENTERTAINMENT
SOFTWARE ASSOCIATION,
Plaintiffs-Appellees,

v.

ARNOLD SCHWARZENEGGER, in his
official capacity as Governor State
of California; EDMUND G. BROWN,
JR., in his official capacity as
Attorney General, State of
California,

Defendants-Appellants,

and

GEORGE KENNEDY, in his official
capacity as Santa Clara County
District Attorney; RICHARD DOYLE,
in his official capacity as City
Attorney for the City of San Jose;
ANN MILLER RAVEL, in her official
capacity as County Counsel for
the County of Santa Clara,

Defendants.

No. 07-16620
D.C. No.
CV-05-04188-RMW
OPINION

Appeal from the United States District Court
for the Northern District of California
Ronald M. Whyte, District Judge, Presiding

Argued and Submitted
October 29, 2008—Sacramento, California

Filed February 20, 2009

Before: Alex Kozinski, Chief Judge, Sidney R. Thomas and
Consuelo M. Callahan, Circuit Judges.

Opinion by Judge Callahan

COUNSEL

Zachery P. Morazzini, Deputy Attorney General for the State of California, on behalf of Defendants-Appellants Arnold Schwarzenegger, in his official capacity as Governor of the State of California, and Edmund G. Brown, in his official capacity as Attorney General of the State of California.

Paul M. Smith, Jenner & Block LLP, on behalf of Plaintiffs-Appellees Video Software Dealers Association and Entertainment Software Association.

OPINION

CALLAHAN, Circuit Judge:

Defendants-Appellants California Governor Schwarzenegger and California Attorney General Brown (the “State”) appeal the district court’s grant of summary judgment in favor of Plaintiffs-Appellees Video Software Dealers Association and Entertainment Software Association (“Plaintiffs”), and the denial of the State’s cross-motion for summary judgment.¹ Plaintiffs filed suit for declaratory relief seeking to invalidate newly-enacted California Civil Code sections 1746-1746.5 (the “Act”), which impose restrictions and a labeling requirement on the sale or rental of “violent video games” to minors,

¹Plaintiffs are associations of companies that create, publish, distribute, sell and/or rent video games, including games that would be potentially regulated under the California statutory scheme at issue.

on the grounds that the Act violates rights guaranteed by the First and Fourteenth Amendments.²

We hold that the Act, as a presumptively invalid content-based restriction on speech, is subject to strict scrutiny and not the “variable obscenity” standard from *Ginsberg v. New York*, 390 U.S. 629 (1968). Applying strict scrutiny, we hold that the Act violates rights protected by the First Amendment because the State has not demonstrated a compelling interest, has not tailored the restriction to its alleged compelling interest, and there exist less-restrictive means that would further the State’s expressed interests. Additionally, we hold that the Act’s labeling requirement is unconstitutionally compelled speech under the First Amendment because it does not require the disclosure of purely factual information; but compels the carrying of the State’s controversial opinion. Accordingly, we affirm the district court’s grant of summary judgment to Plaintiffs and its denial of the State’s cross-motion. Because we affirm the district court on these grounds, we do not reach two of Plaintiffs’ challenges to the Act: first, that the language of the Act is unconstitutionally vague, and, second, that the Act violates Plaintiffs’ rights under the Equal Protection Clause of the Fourteenth Amendment.

I.

A.

On October 7, 2005, Governor Schwarzenegger signed into law Assembly Bill 1179 (“AB 1179”), codified at Civil Code §§ 1746-1746.5.³ The Act states that “[a] person may not sell or rent a video game that has been labeled as a violent video

²All references to “Civil Code” or “section 1746” refer to the California Civil Code unless otherwise indicated.

³During the legislative session, A.B. 1179 had been “guttled” and amended; the language in Assembly Bill 450 (“A.B. 450”) replaced the original language in A.B. 1179.

game to a minor.” Cal. Civ. Code § 1746.1(a).⁴ Violators are subject to a civil penalty of up to \$1,000. *Id.* at § 1746.3.

Central to this appeal, the Act defines a “violent video game” as follows:

(d)(1) “Violent video game” means a video game in which the range of options available to a player includes killing, maiming, dismembering, or sexually assaulting an image of a human being, if those acts are depicted in the game in a manner that does either of the following:

(A) Comes within all of the following descriptions:

(i) A reasonable person, considering the game as a whole, would find appeals to a deviant or morbid interest of minors.

(ii) It is patently offensive to prevailing standards in the community as to what is suitable for minors.

(iii) It causes the game, as a whole, to lack serious literary, artistic, political, or scientific value for minors.

(B) Enables the player to virtually inflict serious injury upon images of human beings or characters with substantially human characteristics in a manner which is especially heinous, cruel, or depraved in

⁴The parties dispute whether the Act bans purchases or rentals by minors who are accompanied by their parents. The Act does not speak to whether there is an exception for sales to minors accompanied by a parent; it states only that it does not apply “if the violent video game is sold or rented to a minor by the minor’s parent, grandparent, aunt, uncle, or legal guardian.” Cal. Civ. Code § 1746.1(c).

that it involves torture or serious physical abuse to the victim.

Id. at § 1746(d)(1).⁵ Borrowing language from federal death penalty jury instructions, the Act also defines the terms “cruel,” “depraved,” “heinous,” and “serious physical abuse,”⁶ and states that “[p]ertinent factors in determining whether a

⁵The State concedes on appeal, consistent with the district court’s conclusion, that the alternate definition of “violent video game” in section 1746(d)(1)(B) is unconstitutional because it “does not provide an exception for material that might have some redeeming value to minors” The State’s contention that this section of the Act is severable based on the severability clause contained in California Civil Code § 1746.5 is subsequently addressed.

⁶Section 1746(d)(2) includes the following definitions:

(A) “Cruel” means that the player intends to virtually inflict a high degree of pain by torture or serious physical abuse of the victim in addition to killing the victim.

(B) “Depraved” means that the player relishes the virtual killing or shows indifference to the suffering of the victim, as evidenced by torture or serious physical abuse of the victim.

(C) “Heinous” means shockingly atrocious. For the killing depicted in a video game to be heinous, it must involve additional acts of torture or serious physical abuse of the victim as set apart from other killings.

(D) “Serious physical abuse” means a significant or considerable amount of injury or damage to the victim’s body which involves a substantial risk of death, unconsciousness, extreme physical pain, substantial disfigurement, or substantial impairment of the function of a bodily member, organ, or mental faculty. Serious physical abuse, unlike torture, does not require that the victim be conscious of the abuse at the time it is inflicted. However, the player must specifically intend the abuse apart from the killing.

(E) “Torture” includes mental as well as physical abuse of the victim. In either case, the virtual victim must be conscious of the abuse at the time it is inflicted; and the player must specifically intend to virtually inflict severe mental or physical pain or suffering upon the victim, apart from killing the victim.

killing depicted in a video game is especially heinous, cruel, or depraved include infliction of gratuitous violence upon the victim beyond that necessary to commit the killing, needless mutilation of the victim's body, and helplessness of the victim."⁷ *Id.* at § 1746(d)(2)-(3).

The Act also imposes a labeling requirement. It requires that each "violent video game" imported into or distributed in California must "be labeled with a solid white '18' outlined in black," which shall appear on the front face of the game's package and be "no less than 2 inches by 2 inches" in size. *Id.* at § 1746.2.

A.B. 1179 states that the State of California has two compelling interests that support the Act: (1) "preventing violent, aggressive, and antisocial behavior"; and (2) "preventing psychological or neurological harm to minors who play violent video games." A.B. 1179 also "finds and declares" that:

- (a) Exposing minors to depictions of violence in video games, including sexual and heinous violence, makes those minors more likely to experience feelings of aggression, to experience a reduction of activity in the frontal lobes of the brain, and to exhibit violent antisocial or aggressive behavior.
- (b) Even minors who do not commit acts of violence suffer psychological harm from prolonged exposure to violent video games.

The State included in the excerpts of record several hundred pages of material on which the Legislature purportedly relied in passing the Act. While many of the materials are social science studies on the asserted impact of violent video

⁷Legislative materials in the record indicate that the Legislature used these terms in the Act because they survived claims of unconstitutionality in *United States v. Jones*, 132 F.3d 232 (5th Cir. 1998).

games on children, other documents are varied and include legal analyses, general background papers, position papers, etc. Dr. Craig Anderson, whose work is central to the State's arguments in this case, is listed as an author of roughly half of the works included in the bibliography.

B.

The content of the video games potentially affected by the Act is diverse. Some of the games to which the Act might apply are unquestionably violent by everyday standards, digitally depicting what most people would agree amounts to murder, torture, or mutilation. For example, the State submitted a videotape that contains several vignettes from the games *Grand Theft Auto: Vice City*, *Postal 2*, and *Duke Nukem 3D*, which demonstrate the myriad ways in which characters can kill or injure victims or adversaries.⁸ The record also contains descriptions of several games, some of which are based on popular novels or motion pictures, which are potentially covered by the Act. Many of these games have extensive plot lines that involve or parallel historical events, mirror common fictional plots, or place the player in a position to evaluate and make moral choices.

The video game industry has in place a voluntary rating system to provide consumers and retailers information about video game content. The Entertainment Software Rating Board ("ESRB"), an independent, self-regulated body established by the Entertainment Software Association, rates the content of video games that are voluntarily submitted. ESRB assigns each game one of six age-specific ratings, ranging from "Early Childhood" to "Adults Only."⁹ It also assigns to

⁸We note that the State's videotape contains heavily edited selections of the violence that can be meted out, but does not include any context or possible storyline within which the violence occurs.

⁹The age ratings include "EC" (Early Childhood), "E" (Everyone), "E10+" (Everyone Ten and Older), "T" (Teen [13+]), "M" (Mature [17+]), and "AO" (Adults Only [18+]).

each game one of roughly thirty content descriptors, which include “Animated Blood,” “Blood and Gore,” “Cartoon Violence,” “Crude Humor,” “Fantasy Violence,” “Intense Violence,” “Language,” “Suggestive Themes,” and “Sexual Violence.”

C.

On October 17, 2005, before the Act took effect, Plaintiffs filed suit against the Governor, the Attorney General, and three city and county defendants, all in their official capacities, for declaratory relief against the Act on the grounds that it violated 42 U.S.C. § 1983 and the First and Fourteenth Amendments. Plaintiffs argued that the Act unconstitutionally restricted freedom of expression on its face based on content regulation and the labeling requirement, was unconstitutionally vague, and violated equal protection.

The district court granted Plaintiffs’ motion for a preliminary injunction. *Video Software Dealers Ass’n v. Schwarzenegger*, 401 F. Supp. 2d 1034 (N.D. Cal. 2005). Subsequently, the parties filed cross-motions for summary judgment. The district court granted Plaintiffs’ motion and denied the State’s cross-motion. *See Video Software Dealers Ass’n v. Schwarzenegger*, No. C-05-04188, slip op. (N.D. Cal. Aug. 6, 2007). The district court’s summary judgment order invalidated the Act under strict scrutiny, and did not reach Plaintiffs’ claims regarding vagueness, equal protection, or the Act’s labeling requirement. The district court permanently enjoined enforcement of the Act. The State timely appealed.

II.

We review a grant of summary judgment de novo and must “determine, viewing the evidence in the light most favorable to the nonmoving party, whether there are any genuine issues of material fact and whether the district court correctly applied substantive law.” *Ballen v. City of Redmond*, 466 F.3d

736, 741 (9th Cir. 2006) (citation and internal quotation marks omitted). We draw all reasonable inferences supported by the evidence in the nonmoving party's favor. *Id.* We “may affirm summary judgment on any ground supported by the record.” *Doran v. 7-Eleven, Inc.*, 524 F.3d 1034, 1039 n.3 (9th Cir. 2008).

III.

[1] We first address Plaintiffs' argument that the entire Act should be invalidated based on the State's concession on appeal that the alternate definition of “violent video game” found in section 1746(d)(1)(B) is unconstitutionally broad. The State counters that the Act is saved by the severability clause in Civil Code § 1746.5, which states: “The provisions of this title are severable. If any provision of this title or its application is held to be invalid, that invalidity shall not affect other provisions or applications that can be given effect without the invalid provision or application.” We hold that the Act is not wholly invalid as a result of the State's concession.

[2] We look to state law to determine the effect of the severability clause. *Qwest Commc'ns Inc. v. City of Berkeley*, 433 F.3d 1253, 1259 (9th Cir. 2006), *overruled on other grounds*, *Sprint Telephony PCS, L.P. v. County of San Diego*, 543 F.3d 571 (9th Cir. 2008) (en banc). Under California law, there is a general presumption in favor a statute's constitutionality. *Ex parte Blaney*, 184 P.2d 892, 900 (Cal. 1947) (“[T]he general presumption of constitutionality, fortified by the express statement of a severability clause, normally calls for sustaining any valid portion of statute unconstitutional in part.”). An invalid portion of a statute

can be severed if, and only if, it is “grammatically, functionally and volitionally separable.” It is “grammatically” separable if it is “distinct” and “separate” and, hence, “can be removed as a whole without affecting the wording of any” of the measure's

“other provisions.” It is “functionally” separable if it is not necessary to the measure’s operation and purpose. And it is “volitionally” separable if it was not of critical importance to the measure’s enactment.

Hotel Employees & Rest. Employees Int’l Union v. Davis, 981 P.2d 990, 1009 (Cal. 1999) (citations omitted); *see also Jevne v. Superior Court*, 111 P.3d 954, 971 (Cal. 2005).

[3] Section 1746(d)(1)(B) is grammatically and functionally separable because, as an alternate definition of “violent video game,” it can be removed from the Act without affecting the wording or function of the Act’s other provisions. Plaintiffs contend, however, that such a deletion does not account for the phrase “does either of the following” in section 1746(d)(1), which is the lead-in language to the alternate definitions of “violent video game,” and that retaining this phrase results in a “conundrum and grammatical error.” Plaintiffs’ concerns are accounted for by the simultaneous deletion of the phrase “does either of the following.” Although some California cases speak in general terms of separability “as a whole,” *see, e.g., Jevne*, 111 P.3d at 972, the California Supreme Court has also evaluated grammatical and functional separability with respect to whether the valid and invalid portions of a statute or initiative can be “separated by paragraph, sentence, clause, phrase, or even single words.” *Santa Barbara Sch. Dist. v. Superior Court of Santa Barbara County*, 530 P.2d 605, 617 (Cal. 1975); *see also Ex parte Blaney*, 184 P.2d at 900; *accord Schweitzer v. Westminster Invs.*, 69 Cal. Rptr. 3d 472, 485 (Ct. App. 2007). Here, the phrase “does either of the following” can be cleanly stricken without doing violence to the rest of the Act or impermissibly reading into the statute any exceptions or qualifications. *See Fort v. Civ. Serv. Comm’n of Alameda County*, 392 P.2d 385, 390 (Cal. 1964).¹⁰

¹⁰Although not argued by the parties, we note that deleting Civil Code § 1746(d)(1)(B) also appears to require the deletion of sections 1746(d)(2) and (d)(3)—which define when a violent act is “cruel,” “depraved,” or “heinous,” or involves “serious physical abuse” or “torture”—because these sections only relate to or explain section 1746(d)(1)(B).

[4] Sections 1746(d)(1)(B), (d)(2), and (d)(3) are also volitionally separable. We must ask whether the inclusion of these sections was of critical importance to passage of the Act and whether the Act “would have been adopted by the legislative body had [it] foreseen the partial invalidation of the statute.” *Sonoma County Org. of Pub. Employees v. County of Sonoma*, 591 P.2d 1, 14 (Cal. 1979) (citation and internal quotation marks omitted). Evidence in the record indicates that the Legislature included sections 1746(d)(1)(B), (d)(2) and (d)(3) in the Act with the express goal of avoiding the constitutional pitfalls identified in *Video Software Dealers Association v. Maleng*, 325 F. Supp. 2d 1180 (W.D. Wash. 2004). An Assembly Judiciary Committee Mandatory Information Worksheet to A.B. 450 and a Research Summary to A.B. 450 both indicate that these detailed definition sections were included in the Act for the purpose of avoiding the result in *Maleng*, where a Washington district court struck down a 2003 state statute, in part, because it was not narrowly tailored. Further, the Assembly Third Reading to A.B. 450 also discusses the tailoring issues in *Maleng*, and notes that the Act “regulates the sale of only those games that contain the most heinous, cruel or depraved acts of violence.” Nonetheless, the record does not persuade us that sections 1746(d)(1)(B), (d)(2) and (d)(3) were “critical” to the passage of the Act. The fact that the Legislature included an alternate definition for “violent video game” designed to help the Act withstand a constitutional challenge does not necessarily indicate that it would not have passed the Act but for the inclusion of these sections. Accordingly, in light of California’s presumption in favor of retaining constitutional parts of statutes, we conclude that the Act is not wholly invalid as a result of the State’s concession.

IV.

[5] Our next task is to determine what level of scrutiny to apply in reviewing the Act’s prohibitions. Existing case law indicates that minors are entitled to a significant measure of

First Amendment protections, that content-based regulations are presumptively invalid and subject to strict scrutiny, and that if less restrictive means for achieving a state's compelling interest are available, they must be used. The State's argument on appeal, that we should not apply strict scrutiny and instead should apply a "variable obscenity" standard from *Ginsberg v. New York*, 390 U.S. 629 (1968), raises a question of first impression in this circuit.

[6] The Supreme Court has stated that "minors are entitled to a significant measure of First Amendment protection, and only in relatively narrow and well-defined circumstances may government bar public dissemination of protected materials to them." *Erznoznik v. City of Jacksonville*, 422 U.S. 205, 212-13 (1975) (citations omitted). The State does not contest that video games are a form of expression protected by the First Amendment.¹¹ See *Interactive Digital Software Ass'n v. St. Louis*, 329 F.3d 954, 956-58 (8th Cir. 2003) (holding that "violent" video games are a protected form of speech); *Maleng*, 325 F. Supp. 2d at 1184-85 (same). It is also undisputed that the Act seeks to restrict expression in video games based on its content. See *Ctr. for Bio-Ethical Reform, Inc. v. Los Angeles County Sheriff Dep't*, 533 F.3d 780, 787 (9th Cir. 2008) ("[A] law is content-based if either the main purpose in enacting it was to suppress or exalt speech of a certain content, or it differentiates based on the content of speech on its face." (citation and internal quotation marks omitted)); *Interactive Digital Software Ass'n*, 329 F.3d at 958 (holding that an ordinance that applied to graphically violent video games was a content-based restriction).

¹¹The Supreme Court has not specifically commented on whether video games contain expressive content protected under the First Amendment; however, story-laden video games of the type potentially covered under the Act are similar to movies, which the Court has long held are protected expression notwithstanding their ability to entertain as well as inform. See, e.g., *Joseph Burstyn, Inc. v. Wilson*, 343 U.S. 495, 501-02 (1952).

“Content-based regulations are presumptively invalid.” *R.A.V. v. City of St. Paul*, 505 U.S. 377, 382 (1992). We ordinarily review content-based restrictions on protected expression under strict scrutiny, and thus, to survive, the Act “must be narrowly tailored to promote a compelling Government interest.” *United States v. Playboy Entm’t Group, Inc.*, 529 U.S. 803, 813 (2000). “If a less restrictive alternative would serve the Government’s purpose, the legislature must use that alternative.” *Id.*; see also *Sable Commc’ns of Cal., Inc. v. FCC*, 492 U.S. 115, 126 (1989) (“The Government may . . . regulate the content of constitutionally protected speech in order to promote a compelling interest if it chooses the least restrictive means to further the articulated interest.”); *Reno v. ACLU*, 521 U.S. 844, 876-77 (1997) (finding relevant the fact that a reasonably effective method by which parents could prevent children from accessing internet material which parents believed to be inappropriate “will soon be widely available”).

The State, however, urges us to depart from this framework because the Act concerns minors. It argues that we should analyze the Act’s restrictions under what has been called the “variable obscenity” or “obscenity as to minors” standard first mentioned in *Ginsberg*, 390 U.S. 629. In essence, the State argues that the Court’s reasoning in *Ginsberg* that a state could prohibit the sale of sexually-explicit material to minors that it could not ban from distribution to adults should be extended to materials containing violence. This presents an invitation to re-consider the boundaries of the legal concept of “obscenity” under the First Amendment.

[7] In *Ginsberg*, the Court held that New York State could prohibit the sale of sexually-explicit material to minors that was defined by statute as obscene because of its appeal to minors. *Id.* at 643, 646. Therefore, the state could prohibit the sale of “girlie magazines” to minors regardless of the fact that the material was not considered obscene for adults. *Id.* at 643. The Court stated that “[t]o sustain the power to exclude mate-

rial defined as obscenity by [the statute] requires only that we be able to say that it was not irrational for the legislature to find that exposure to material condemned by the statute is harmful to minors.”¹² *Id.* at 641. The Court offered two justifications for applying this rational basis standard: (1) that “constitutional interpretation has consistently recognized that the parents’ claim to authority in their own household to direct the rearing of their children is basic in the structure of our society”; and (2) the state’s “independent interest in the well-being of its youth.” *Id.* at 639-40.

The State suggests that the justifications underlying *Ginsberg* should apply to the regulation of violent content as well as sexually explicit material. The assertion, however, fails when we consider the category of material to which the *Ginsberg* decision applies and the First Amendment principles in which that decision was rooted.

[8] *Ginsberg* is specifically rooted in the Court’s First Amendment obscenity jurisprudence, which relates to non-protected sex-based expression—not violent content, which is presumably protected by the First Amendment. *See* 390 U.S. at 640. *Ginsberg* explicitly states that the New York statute under review “simply adjusts the definition of obscenity to social realities by permitting the appeal of this type of material to be assessed in term of the sexual interests of such minors.” *Id.* at 638 (citation, internal quotation marks, and alterations omitted). The definition of obscenity that *Ginsberg* adjusted was the Court’s obscenity test announced in *Roth v. United States*, which dealt with obscene materials defined with reference to sex. 354 U.S. 476, 485-87 (1957) (discuss-

¹²The statute in *Ginsberg* used the defined term “harmful to minors,” which prohibited access by minors when it: “(i) predominantly appeals to the prurient, shameful or morbid interest of minors, and [¶] (ii) is patently offensive to prevailing standards in the adult community as a whole with respect to what is suitable material for minors, and [¶] (iii) is utterly without redeeming social importance for minors.” *Id.* at 646.

ing the nature of obscenity at length and stating, among other things, that “[o]bscene material is material which deals with sex in a manner appealing to prurient interest.”). The *Ginsberg* Court applied a rational basis test to the statute at issue because it placed the magazines at issue within a sub-category of obscenity—obscenity as to minors—that had been determined to be not protected by the First Amendment, and it did not create an entirely new category of expression excepted from First Amendment protection. The State, in essence, asks us to create a new category of non-protected material based on its depiction of violence.

The Supreme Court has carefully limited obscenity to sexual content. Although the Court has wrestled with the precise formulation of the legal test by which it classifies obscene material, it has consistently addressed obscenity with reference to sex-based material. Such was the case in *Roth* and *Memoirs v. Massachusetts*, 383 U.S. 413 (1966), which modified *Roth*. And though it post-dates *Ginsberg*, the Court in *Miller v. California* expressly cabined the First Amendment concept of obscenity in terms of sexual material. 413 U.S. 15, 24 (1973) (“[W]e now confine the permissible scope of such regulation to works which depict or describe sexual conduct.”)

Circuit courts have resisted attempts to broaden obscenity to cover violent material as well as sexually-explicit material. In *American Amusement Machine Association v. Kendrick*, which involved a video game restriction that mixed the regulation of sexual and violent material, the Seventh Circuit discussed why “[v]iolence and obscenity are distinct categories of objectionable depiction,” explaining that obscenity is concerned with “offensiveness,” whereas ordinances like the one at issue in *Kendrick* (and here) are concerned with conduct or harm. 244 F.3d 572, 574-75 (7th Cir. 2001), *cert. denied*, 534 U.S. 994 (2001).¹³ In *Video Software Dealers Association v.*

¹³Citing one law review article, the State also urges us to redefine the First Amendment meaning of “obscenity”—which involves material

Webster, the Eighth Circuit held that videos “that contain[] violence but not depictions or descriptions of sexual conduct cannot be obscene.” 968 F.2d 684, 688 (8th Cir. 1992) (“Obscenity . . . encompasses only expression that ‘depict[s] or describe[s] sexual conduct’ ” (citing *Miller*, 413 U.S. at 24)). Likewise, in *Eclipse Enterprises, Inc. v. Gullota*, the Second Circuit declined to place trading cards which depicted heinous crime that was allegedly harmful to minors in the category of unprotected obscenity. 134 F.3d 63, 66-68 (2d Cir. 1997). Further, in *James v. Meow Media, Inc.*, the Sixth Circuit, in discussing excessively violent movies and video game material, “decline[d] to extend [its] obscenity jurisprudence to violent, instead of sexually explicit, material.” 300 F.3d 683, 698 (6th Cir. 2002).

Finally, we note that the *Ginsberg* Court suggested its intent to place a substantive limit on its holding. It stated:

We have no occasion in this case to consider the impact of the guarantees of freedom of expression upon the totality of the relationship of the minor and the State. It is enough for the purposes of this case that we inquire whether it was constitutionally impermissible for New York . . . to accord minors under 17 a more restricted right than that assured to adults to judge and determine for themselves what sex material they may read or see.

related to sex—by substituting an ordinary definition of obscenity based on its Latin root. In *Maleng*, Judge Lasnik rejected the same argument. 325 F. Supp. 2d at 1185. He explained that the phrase “obscene material” was not inherently limited to sexually explicit material in the ordinary sense, and that the Latin root “obscaenus” literally means “filth.” *Id.* Nonetheless, he held, relying on *Miller*, 413 U.S. 15, that “when used in the context of the First Amendment, the word ‘obscenity’ means material that deals with sex.” *Id.* This reasoning, dismissing the linguistic argument, applies equally to the State’s argument here.

Ginsberg, 390 U.S. at 636-37 (citation omitted). Though not the clearest of disclaimers, this language telegraphs that the Court's concern in *Ginsberg* was with the relationship between the state and minors with respect to a certain subject matter—"sex material" as it relates to the interests of minors.

[9] In light of our reading of *Ginsberg* and the cases from our sister circuits, we decline the State's invitation to apply the *Ginsberg* rationale to materials depicting violence, and hold that strict scrutiny remains the applicable review standard.¹⁴ Our decision is consistent with the decisions of several other courts that have addressed and rejected the argument that the *Ginsberg* standard be extended from the field of sex-based content to violence in video games. See *Interactive Digital Software Ass'n*, 329 F.3d at 959; *Kendrick*, 244 F.3d at 576-78; *Entm't Software Ass'n v. Granholm*, 426 F. Supp. 2d 646, 652 (E.D. Mich. 2006); *Maleng*, 325 F. Supp. 2d at 1185-86. At oral argument, the State confirmed that it is asking us to boldly go where no court has gone before. We decline the State's entreaty to extend the reach of *Ginsberg* and thereby redefine the concept of obscenity under the First Amendment.

V.

[10] Accordingly, we review the Act's content-based prohibitions under strict scrutiny. As noted above, "[c]ontent-based regulations are presumptively invalid," *R.A.V.*, 505 U.S. at 382, and to survive the Act "must be narrowly tailored to promote a compelling Government interest." *Playboy Entm't Group, Inc.*, 529 U.S. at 813. Further, "[i]f a less restrictive alternative would serve the Government's purpose, the legislature must use that alternative." *Id.*

¹⁴We also reject the State's more general request that we equate violent content with unprotected "obscenity." As the discussion above indicates, the Court's obscenity jurisprudence limits obscene materials to sex-based materials.

A.

The Legislature stated that it had two compelling interests in passing the Act: (1) “preventing violent, aggressive, and antisocial behavior”; and (2) “preventing psychological or neurological harm to minors who play violent video games.” Although there was some early confusion over whether the State was relying on both of these interests, the State subsequently clarified that “[t]he physical and psychological well-being of children is the concern of the Act,” as distinguished from the interest of protecting third parties from violent behavior. The State’s focus is on the actual harm to the brain of the child playing the video game. Therefore, we will not assess the Legislature’s purported interest in the prevention of “violent, aggressive, and antisocial behavior.”¹⁵

[11] The Supreme Court has recognized that “there is a compelling interest in protecting the physical and psychological well-being of minors.” *Sable Commc’ns of Cal., Inc.*, 492 U.S. at 126; *see also Entm’t Software Ass’n v. Swanson*, 519

¹⁵Throughout this litigation, the parties have disagreed as to what extent *Brandenburg v. Ohio*, 395 U.S. 444 (1969) (per curiam), applies to this case. The dispute stems from the fact that one of the compelling interests advanced by the Legislature is the prevention of “violent, aggressive, and antisocial behavior.” One of the Legislature’s findings was that “[e]xposing minors to depictions of violence in video games . . . makes those minors more likely . . . to exhibit violent antisocial or aggressive behavior.” However, “[t]he government may not prohibit speech because it increases the chance an unlawful act will be committed ‘at some indefinite future time.’” *Ashcroft v. Free Speech Coal.*, 535 U.S. 234, 253 (2002) (citation omitted). It “may suppress speech for advocating the use of force or a violation of law only if ‘such advocacy is directed to inciting or producing imminent lawless action and is likely to incite or produce such action.’” *Id.* (citing *Brandenburg*, 395 U.S. at 447). District courts analyzing the violence prevention rationale have rejected it. *See Entertainment Software Association v. Blagojevich*, 404 F. Supp. 2d 1051, 1073 (N.D. Ill. 2005); *Granholt*, 426 F. Supp. 2d at 652; *Entm’t Software Ass’n v. Foti*, 451 F. Supp. 2d 823, 831 (M.D. La. 2006); *Maleng*, 325 F. Supp. 2d at 1187 n.3.

F.3d 768, 771 (8th Cir. 2008); *Interactive Digital Software Ass'n*, 329 F.3d at 958; *Nunez by Nunez v. City of San Diego*, 114 F.3d 935, 944 (9th Cir. 1997); *Maleng*, 325 F. Supp. 2d at 1186-87. Notwithstanding this abstract compelling interest, when the government seeks to restrict speech “[i]t must demonstrate that the recited harms are real, not merely conjectural, and that the regulation will in fact alleviate these harms in a direct and material way.” *Turner Broad. Sys., Inc. v. FCC*, 512 U.S. 622, 664 (1994) (plurality op.); *Swanson*, 519 F.3d at 771; *Interactive Digital Software Ass'n*, 329 F.3d at 958-59. Although we must accord deference to the predictive judgments of the legislature, our “obligation is to assure that, in formulating its judgments, [the legislature] has drawn reasonable inferences based on substantial evidence.” *Turner Broad. Sys., Inc. v. FCC*, 520 U.S. 180, 195 (1997) (citations and quotation marks omitted); see also *Playboy Entm't Group, Inc.*, 529 U.S. at 822 (“This is not to suggest that a 10,000-page record must be compiled in every case or that the Government must delay in acting to address a real problem; but the Government must present more than anecdote and supposition. The question is whether an actual problem has been proved”).

In evaluating the State’s asserted interests, we must distinguish the State’s interest in protecting minors from actual psychological or neurological harm from the State’s interest in controlling minors’ thoughts. The latter is not legitimate. The Supreme Court has warned that the

government cannot constitutionally premise legislation on the desirability of controlling a person’s private thoughts. First Amendment freedoms are most in danger when the government seeks to control thought or to justify its laws for that impermissible end. The right to think is the beginning of freedom, and speech must be protected from the government because speech is the beginning of thought.

Ashcroft, 535 U.S. at 253 (citation and internal quotation marks omitted.) In *Kendrick*, the Seventh Circuit commented on a psychological harm rationale in the violent video game context:

Violence has always been and remains a central interest of humankind and a recurrent, even obsessive theme of culture both high and low. It engages the interest of children from an early age, as anyone familiar with the classic fairy tales collected by Grimm, Andersen, and Perrault is aware. To shield children right up to the age of 18 from exposure to violent descriptions and images would not only be quixotic, but deforming; it would leave them unequipped to cope with the world as we know it.

244 F.3d at 579; *see also Interactive Digital Software Ass'n*, 329 F.3d at 960 (“Speech that is neither obscene as to youths nor subject to some other legitimate proscription cannot be suppressed solely to protect the young from ideas or images that a legislative body thinks unsuitable for them.”) (citation and quotation marks omitted). Because the government may not restrict speech in order to control a minor’s thoughts, we focus on the State’s psychological harm rationale in terms of some actual effect on minors’ psychological health.

[12] Whether the State’s interest in preventing psychological or neurological harm to minors is legally compelling depends on the evidence the State proffers of the effect of video games on minors. Although the Legislature is entitled to some deference, the courts are required to review whether the Legislature has drawn reasonable inferences from the evidence presented. *See Turner Broad. Sys., Inc.*, 520 U.S. at 195. Here, the State relies on a number of studies in support of its argument that there is substantial evidence of a causal effect between minors playing violent video games and actual psychological harm.

The State relies heavily on the work of Dr. Craig Anderson, pointing to Dr. Anderson's 2004 updated meta-analysis called *An update on the effects of playing violent video games*.¹⁶ Craig A. Anderson, *An update on the effects of playing violent video games*, 27 J. ADOLESCENCE 113 (2004). This article states that it "reveals that exposure to violent video games is significantly linked to increases in aggressive behaviour, aggressive cognition, aggressive affect, and cardiovascular arousal, and to decreases in helping behaviour." Even upon lay review, however, the disclaimers in this article, alone, significantly undermine the inferences drawn by the State in support of its psychological harm rationale.¹⁷ First, Dr. Anderson remarks on the relative paucity of the video game literature and concedes that the violent video game literature is not sufficiently large to conduct a detailed meta-analysis of the specific methodological features of other studies, many of which were themselves flawed. Second, he further states that "[t]here is not a large enough body of samples . . . for truly sensitive tests of potential age difference in susceptibility to violent video game effects," and jettisons mid-article his exploration of the effect of age differences (i.e., over-eighteen versus under-eighteen). It appears that he abandoned the age aspect of the study, in part, because "there was a hint that the aggressive behaviour results might be slightly larger for the 18 and over group." He concludes the meta-analysis with the admission that there is a "glaring empirical gap" in video game violence research due to "the lack of longitudinal studies."

¹⁶Meta-analysis is "a quantitative method for integrating existing studies" where "statistical procedures are used to assess the magnitude of a phenomenon across different studies, independent of the studies' sample sizes." David L. Faigman et al., 2 MOD. SCI. EVIDENCE § 18:13 (2005-06 Ed.).

¹⁷Dr. Anderson's hearing testimony in the *Blagojevich* case, which is in the record, contains his assent to the statements that there is probably an "infinite" number of stimuli that could cause aggression or aggressive thoughts in a person (e.g., a picture of a gun), and that his selection of violent video games was "largely a matter of [his] choice."

Thus, Dr. Anderson's research has readily admitted flaws that undermine its support of the State's interest in regulating video games sales and rentals to minors, perhaps most importantly its retreat from the study of the psychological effects of video games as related to the age of the person studied.¹⁸ Although not dispositive of this case, we note that other courts have either rejected Dr. Anderson's research or found it insufficient to establish a causal link between violence in video games and psychological harm. *See Kendrick*, 244 F.3d at 578; *Granholm*, 426 F. Supp. 2d at 653; *Entm't Software Ass'n v. Hatch*, 443 F. Supp. 2d 1065, 1069 & n.1 (D. Minn. 2006); *Blagojevich*, 404 F. Supp. 2d at 1063.

The State also relies on a study of the effects of video game violence on adolescents, conducted by Dr. Douglas Gentile, which studied eighth and ninth graders and concluded that “[a]dolescents who expose themselves to greater amounts of video game violence were more hostile” and reported getting into more arguments and fights and performing poorly in school. Douglas A. Gentile et al., *The effects of violent video game habits on adolescent hostility, aggressive behaviors, and school performance*, 27 J. ADOLESCENCE 5 (2004). The extent to which this study supports the State's position is suspect for similar reasons as Dr. Anderson's work. First, this study states that due to its “correlational nature” it could not directly answer the following question: “Are young adolescents more hostile and aggressive because they expose themselves to media violence, or do previously hostile adolescents prefer violent media?” Second, this study largely relates to the player's violent or aggressive behavior toward others—which,

¹⁸The State also relies on a 2003 study on general media violence by Dr. Anderson, which contains a three-page section on violent video games and reflects the conclusions and shortfalls of the 2004 meta-analysis. Craig A. Anderson et al., *The Influence of Media Violence on Youth*, 4 PSYCHOLOGICAL SCIENCE IN THE PUBLIC INTEREST 81, 90-93 (2003). For example, the study states that “[t]here are no published longitudinal surveys specifically focusing on effects of violent video games on aggression.”

as noted above, is not the interest relied on by the State here—rather than the psychological or neurological harm to the player. Moreover, the study glaringly states that “[i]t is important to note . . . that this study is limited by its correlational nature. *Inferences about causal direction should be viewed with caution*” (emphasis added). Finally, Dr. Gentile’s study suggests that “[a]dditional experimental and longitudinal research is needed.”

Additionally, the State relies on a study by Dr. Jeanne Funk for the proposition that video games can lead to desensitization to violence in minors. Jeanne B. Funk et al., *Violence exposure in real-life, video games, television, movies, and the internet: is there desensitization?*, 27 J. ADOLESCENCE 23 (2004). Like the others, this study presents only an attenuated path between video game violence and desensitization. It specifically disclaims that it is based on correlation principles and that “causality was not studied.”

Finally, the State relies on a two-page press release from Indiana University regarding the purported connection between violent video games and altered brain activity in the frontal lobe. Press Release, Indiana University School of Medicine, Aggressive Youths, Violent Video Games Trigger Unusual Brain Activity (Dec. 2, 2002). The research described, conducted in part by Dr. Kronenberger, has been criticized by courts that have reviewed it in depth. *See Blagojevich*, 404 F. Supp. 2d at 1063-65 (“Dr. Kronenberger conceded that his studies only demonstrate a correlative, not a causal, relationship between high media violence exposure and children who experience behavioral disorders [or] decreased brain activity”); *Granholm*, 426 F. Supp. 2d at 653 (“Dr. Kronenberger’s research not only fails to provide concrete evidence that there is a connection between violent media and aggressive behavior, it also fails to distinguish between video games and other forms of media.”).

[13] In sum, the evidence presented by the State does not support the Legislature’s purported interest in preventing psy-

chological or neurological harm. Nearly all of the research is based on correlation, not evidence of causation, and most of the studies suffer from significant, admitted flaws in methodology as they relate to the State's claimed interest. None of the research establishes or suggests a causal link between minors playing violent video games and actual psychological or neurological harm, and inferences to that effect would not be reasonable. In fact, some of the studies caution against inferring causation. Although we do not require the State to demonstrate a "scientific certainty," the State must come forward with more than it has. As a result, the State has not met its burden to demonstrate a compelling interest.

B.

Even if we assume that the State demonstrated a compelling interest in preventing psychological or neurological harm, the State still has the burden of demonstrating that the Act is narrowly tailored to further that interest, and that there are no less restrictive alternatives that would further the Act. *Playboy Entm't Group, Inc.*, 529 U.S. at 813. We hold that the State has not demonstrated that less restrictive alternative means are not available.

Instead of focusing its argument on the possibility of less restrictive means, the State obscures the analysis by focusing on the "most effective" means, which it asserts is the one thousand dollar penalty imposed for each violation. Specifically, the State argues that the ESRB rating system, a voluntary system without the force of law or civil penalty, is not a less-restrictive alternative means of furthering the Legislature's purported compelling interest. Acknowledging that the industry has implemented new enforcement mechanisms, the State nevertheless argues that the ESRB does not adequately prevent minors from purchasing M-rated games. The State also dismisses the notion that parental controls on modern gaming systems could serve the government's purposes, arguing that there is no evidence that this technology existed at the

time the Act was passed. *But see Foti*, 451 F. Supp. 2d at 833 (suggesting that such controls could be a less-restrictive measure); *cf. Reno*, 521 U.S. at 876-77 (finding relevant the fact that a reasonably effective method by which parents could prevent children from accessing internet material which parents believed to be inappropriate “will soon be widely available”).

Further, the State does not acknowledge the possibility that an enhanced education campaign about the ESRB rating system directed at retailers and parents would help achieve government interests. *See also Playboy*, 529 U.S. at 816 (“When a plausible, less restrictive alternative is offered to a content-based speech restriction, it is the Government’s obligation to prove that the alternative will be ineffective to achieve its goals.”); *44 Liquormart, Inc. v. Rhode Island*, 517 U.S. 484, 507-08 (1996) (plurality op.) (striking down ban on advertising alcohol prices because of less restrictive alternatives, such as an educational campaign or counter-speech). The State appears to be singularly focused on the “most effective” way to further its goal, instead of the “least restrictive means,” and has not shown why the less-restrictive means would be ineffective.

[14] Even assuming that the State’s interests in enacting the Act are sufficient, the State has not demonstrated why less restrictive means would not forward its interests. The Act, therefore, is not narrowly tailored. Based on the foregoing, and in light of the presumptive invalidity of content-based restrictions, we conclude that the Act fails under strict scrutiny review.

VI.

Finally, we evaluate the constitutionality of the Act’s labeling provision, which requires that the front side of the package of a “violent video game” be labeled with a four square-inch label that reads “18.” Cal. Civ. Code § 1746.2. Plaintiffs

argue that section 1746.2 unconstitutionally forces video game retailers to carry the State of California's subjective opinion, a message with which it disagrees. The State counters that the "labeling provision impacts the purely commercial aspect regarding retail sales of the covered video games" and, under the resulting rational basis analysis, the labeling requirement is rationally related to the State's "self-evident purpose of communicating to consumers and store clerks that the video game cannot be legally purchased by anyone under 18 years of age."

[15] Generally, "freedom of speech prohibits the government from telling people what they must say." *Rumsfeld v. Forum for Academic & Institutional Rights, Inc.*, 547 U.S. 47, 61 (2006); see also *United States v. United Foods, Inc.*, 533 U.S. 405, 410 (2001); *Riley v. Nat'l Fed'n of the Blind*, 487 U.S. 781, 795 (1988). Commercial speech, however, is generally accorded less protection than other expression. See *United Foods, Inc.*, 533 U.S. at 409. The Court has upheld compelled commercial speech where the state required inclusion of "purely factual and uncontroversial information" in advertising. See *Zauderer v. Office of Disciplinary Counsel*, 471 U.S. 626, 651 (1985) (upholding state's requirement that attorney include in his advertisements a disclosure that clients may be responsible for litigation costs); see also *United States v. Schiff*, 379 F.3d 621, 630-31 (9th Cir. 2004) (holding that the government could compel website operator to post factual information about potential criminal liability if patrons used website to evade taxes); *Nat'l Elec. Mfrs. Ass'n v. Sorrell*, 272 F.3d 104, 113-15 (2d Cir. 2001) (upholding state labeling law that required manufacturers of mercury-containing products to disclose on packaging factual and uncontroversial information about the disposal of mercury-containing products). Compelled disclosures, justified by the need to "dissipate the possibility of consumer confusion or deception," are permissible if the "disclosure requirements are reasonably related to the

State's interest in preventing deception of customers." *Zauderer*, 471 U.S. at 651.¹⁹

[16] Ordinarily, we would initially decide whether video game packaging constitutes separable commercial speech or commercial speech that is "inextricably intertwined" with otherwise fully-protected speech. *See Riley*, 487 U.S. at 795-96 (stating that "[i]t is not clear that . . . speech is necessarily commercial whenever it relates to [a] person's financial motivation for speaking"). That analysis would direct what level of scrutiny to apply to the labeling requirement. However, we need not decide that question because the labeling requirement fails even under the factual information and deception prevention standards set forth in *Zauderer*.²⁰ Our holding above, that the Act's sale and rental prohibition is unconstitutional, negates the State's argument that the labeling provision only requires that video game retailers carry "purely factual and uncontroversial information" in advertising. *Zauderer*, 471 U.S. at 651. Unless the Act can clearly and legally characterize a video game as "violent" and not subject to First Amendment protections, the "18" sticker does not convey factual information.

¹⁹Heightened scrutiny may apply, however, if the commercial speech is "inextricably intertwined" with otherwise fully-protected speech, e.g., political speech, charitable solicitations. *Riley*, 487 U.S. at 796; *Cal-Almond, Inc. v. U.S. Dep't of Agric.*, 14 F.3d 429, 436 (9th Cir. 1993).

²⁰We note that on similar facts, the Seventh Circuit, in *Entertainment Software Association v. Blagojevich*, struck down a statute's requirement that video game retailers affix a four square-inch sticker reading "18" on any video game the state defined as "sexually explicit." 469 F.3d 641, 651-52 (7th Cir. 2006). The court applied strict scrutiny because, in its view, the label did not concern the disclosure of "purely factual" information—the label reflected the state's opinion that the product contained material that the state deemed "sexually explicit" and communicated a "subjective and highly controversial message." *Id.* at 652. We do not adopt the *Blagojevich* court's approach here because it is not clear what authority supported its application of strict scrutiny, and we conclude that the labeling requirement here is invalid under a less-strict review standard.

Moreover, the labeling requirement fails *Zauderer's* rational relationship test, which asks if the “disclosure requirements are reasonably related to the State’s interest in preventing deception of customers.” *Id.* at 651. Our determination that the Act is unconstitutional eliminates the alleged deception that the State’s labeling requirement would purportedly prevent: the misleading of consumers and retailers by the ESRB age ratings that already appear on the video games’ packaging. Since the Act is invalid and, as a result, there is no state-mandated age threshold for the purchase or rental of video games, there is no chance for deception based on the possibly conflicting ESRB rating labels. In fact, the State’s mandated label would arguably now convey a false statement that certain conduct is illegal when it is not, and the State has no legitimate reason to force retailers to affix false information on their products. *See Hatch*, 443 F. Supp. 2d at 1072, *aff’d on other grounds*, *Swanson*, 519 F.3d 768.

VII.

We decline the State’s invitation to apply the variable obscenity standard from *Ginsberg* to the Act because we do not read *Ginsberg* as reaching beyond the context of restrictions on sexually-explicit materials or as creating an entirely new category of expression—speech as to minors—excepted from First Amendment protections. As the Act is a content based regulation, it is subject to strict scrutiny and is presumptively invalid. Under strict scrutiny, the State has not produced substantial evidence that supports the Legislature’s conclusion that violent video games cause psychological or neurological harm to minors. Even if it did, the Act is not narrowly tailored to prevent that harm and there remain less-restrictive means of forwarding the State’s purported interests, such as the improved ESRB rating system, enhanced educational campaigns, and parental controls. Finally, even if the Act’s labeling requirement affects only commercial speech in the form of video game packaging, that provision constitutes impermissibly compelled speech because the compelled label

would not convey purely factual information. Accordingly, the district court's grant of summary judgment to Plaintiffs and denial of the State's cross-motion for summary judgment is **AFFIRMED**.



Janna Smith

Legal Counsel
Director of Legal and Business Affairs
NAMCO BANDAI GAMES AMERICA INC.

Janna Smith is an experienced IP attorney with a comprehensive background in the video game, entertainment, and software industries. She has previously held positions at the Intellectual Property Law Group, LLP in San Jose, CA as IP Attorney, and Orrick, Herrington & Sutcliffe LLP, where she worked in IP litigation. She is currently lead counsel and head of North American IP & Licensing for NAMCO BANDAI Games America, Inc.

Specialties:

Video games; Intellectual Property; Contracts; Immigration;

Education:

- **Juris Doctor** - Santa Clara University School of Law, *Dean's List*
- **Master of Arts, German & European Studies** - Georgetown University, Edmund A. Walsh School of Foreign Service,
- **Bachelor of Science, Political Science/Spanish** - Santa Clara University College of Arts and Sciences
- **Political Science / German** - University of Vienna, Institute für Europäische Studien, Vienna, Austria,

Pamela Ostroff

Pamela Ostroff is currently Senior Counsel at Electronic Arts Inc., a premier publisher of interactive software entertainment products. In this capacity, she supports a group of EA internal development studios, including the BioWare Austin studio which is building the new “Star Wars” based MMO game. In addition, she counsels EA on licensing issues pertaining to social networking sites and entertainment based properties; she provides legal support for EA’s Entertainment division, involving rights acquisition agreements and option/purchase agreements for original EA properties with major motion picture studios and EA Interactive, the EA studio dedicated to social networking applications. Pamela first came to EA in 1997 but spent the 5 years from 2000-2005 in the biotech industry, managing the global patent portfolio pertaining to PCR (polymerase chain reaction) owned by Roche Molecular Systems. In her capacity as Senior Director for Roche, she also negotiated joint research development and licensing agreements with cutting edge biotech companies relating to molecular diagnostic tests for infectious and genetic diseases. Prior experience includes service as in-house counsel in the financial services industry at Wells Fargo Bank and the former Bank of California. She earned a BA in Political Science (Honors Program) from the University of California, Santa Barbara in 1973 and her JD from Golden Gate University Law School in 1977. She is admitted to practice in the State of California and the USDC, Northern California.

Jed Ritchey

Jed Ritchey is a senior member of the legal team at Zynga Game Network Inc. in San Francisco. Zynga is a leading social gaming company with a mission of connecting the world through games. Jed has a decade of in-house counsel experience with technology companies having served in senior legal positions with NextWave Wireless and Support.com. Prior to moving in-house, Jed litigated intellectual property and commercial disputes and advised startup companies at Hoge Fenton Jones & Appel in San Jose. He also served as a Judicial Extern to the Honorable Judge James Ware in the United States District Court for the Northern District of California. Jed received his bachelor's degree from University California at Davis and his law degree from Santa Clara University, where he served on the law review.



Steve Rubin

www.stephenrubin.com

Steve Rubin represents independent game developers and distributors in such matters as intellectual property protection and enforcement, agreements and licenses, litigation, employment law, and business formations, acquisitions and financings. Among his many publications, he is the author of chapters on video game law in *Introduction to Game Development*, now in its second edition, and is an annual speaker at the Game Developers Conference in San Francisco. Steve has been involved in the video game industry for almost 20 years. During that period, he has engaged in contract negotiations and drafting on behalf of developers with every major publisher and console manufacturer. A substantial portion of his practice today relates to social network games and web-based enterprises. In addition to the United States, his clients are located in Canada, China, the Netherlands, Norway and the UK. In recent years, Steve has served as special master to federal judges in patent matters and as a court-appointed mediator. Prior to starting his own firm, Steve was a law clerk to Hon. Harry E. Kalodner of the U.S. Third Circuit Court of Appeals, an appellate attorney in the Antitrust Division of the U.S. Department of Justice, a tenured professor of law at the University of Florida, and a partner at a national firm where he headed the antitrust and intellectual property practices. Steve is a graduate of the University of Pennsylvania and Columbia Law School.

7.5 Intellectual Property Content, Law, and Practice

by Stephen Rubin, Esquire

In This Chapter

- Overview
- Categories of IP Protection
- The IP Content of Video Games
- Patents
- Copyrights
- Trademarks
- Transfers of IP Rights
- Trade Secrets
- Avoiding IP Infringement
- Summary
- Exercises
- References

Overview

To the creative, technological, managerial, and financial layers of video game study add another: the law of intellectual property. Where a player sees seamless on-screen interactive gameplay, and a developer sees original characters, artwork, backgrounds, storylines, dialogue, music, and sounds brought to life by software game engines and tools, a lawyer sees an amalgam of patents, copyrights, publicity rights, moral rights, trademarks, and trade secrets. To an increasing extent, video game development choices, and ultimately what appears on the player's screen, are shaped by the web of rights and remedies the legal system collects under the heading of intellectual property. Intellectual property often is abbreviated IP, and that designation will be used here.

A working definition of intellectual property is the bundle of rights to the intangible creations and inventions of the human intellect.

It is useful to think of IP rights as a bundle because it is possible to subdivide rights based on factors such as use, duration, exclusivity, transferability, and geographic scope. IP rights have complementary parts: the right to exploit and the right to control

exploitation by others. For example, a developer's right to prevent others from reproducing a game is fundamental to the developer's right to be compensated for the assignment of the game IP to a publisher. IP is intangible. IP is not the book or CD, but rather ownership rights to the written expression contained in the book or audiovisual recording on the CD. A book and CD can be physically possessed and have a finite presence. The written expression or audiovisual recording can be perceived through an expanding array of technology, including the Internet. Consequently, they can have virtually limitless presence. This combination of factors, the intangible nature of IP rights and technological advances in IP reproduction and distribution, present the great challenge to the enforcement of IP rights today.

The allocation and enforcement of IP rights is governed by national and sometimes local laws, government agencies, and international treaties that pertain to patents, copyrights, trademarks, and trade secrets. These laws, primarily the IP laws of the United States, are the focus of this chapter. The emphasis will be on video game IP. However, the application of these laws extends far wider, to all manner of scientific, technological, literary, artistic, and commercial creations, discoveries, and inventions.

This chapter is a distillation of what are complex and evolving IP laws and principles. It should be noted that the description of particular laws and principles may be subject to unstated qualifications or omissions. IP laws and principles can and do change and can vary significantly among different jurisdictions. This chapter does not constitute legal advice, which should be obtained through consultation with an attorney in the context of specific facts.

Categories of IP Protection

It will be useful to start with an introduction to the principles that govern the major forms of IP protection and to consider their interrelation.

A patent protects certain novel, useful, and nonobvious inventions having a utilitarian function.

The owner of a United States patent has rights superior to all subsequent inventors, but for a limited term that is currently 20 years. Rights to an invention are not protected from use by others unless a patent is obtained from the United States Patent and Trademark Office (USPTO). In exchange for the monopoly IP rights granted to the patentee during the patent term, the patentee must make a full public disclosure of the invention in the patent. This disclosure may be freely exploited by anyone once the patent expires. Patents permeate the hardware technology on which video games are played. So-called method patents are used to secure a monopoly in particular forms of gameplay or software functionality, although as later discussed such method patents are the subject of increasing criticism and judicial limitation.

Unlike the 20-year term of patents, exclusive IP rights to an invention, discovery, or other confidential and commercially valuable information can be maintained indefinitely as a trade secret. The owner of a trade secret can preclude others from disclosing nonpublic information obtained from the owner. However, unlike a patent holder,

the owner of a trade secret cannot stop independent discovery and use of such information. A patent does not protect ideas, only the functional embodiment or implementation of an idea in a new and useful device or method. A trade secret can be used to protect the idea itself from use by others. The protection accorded trade secrets is a matter of federal and individual state laws, the latter of which often are modeled upon the Uniform Trade Secrets Act.

A copyright protects creative expression in any fixed medium such as books, film, CDs, videotape, records, and computer hard drives. As with patents, copyrights do not protect ideas, only their expression. This limitation applies to so-called *scènes a faire*—stock literary devices like plots, incidents, scenes, and characters. In the field of video games, this concept is captured in the term “genre.” It enables such similar games as *Street Fighter*, *Virtua Fighter*, and *Mortal Kombat* to coexist without copyright infringement. Copyright protects against only actual copying; therefore, another person can claim rights to identical expression so long as it was not copied. Theoretically, two people working without knowledge of each other could paint the same picture, write the same software, or take the same photograph. Each could copyright their creative work. The concept of copyright “expression” does not include individual words, names, or titles. Hence, the title of a video game such as *Halo* cannot be copyrighted. However, it may be trademarked if it serves to identify the source of the game to consumers. The duration of a copyright currently is the life of the author/artist plus seventy years, or a fixed period, as discussed below, for anonymous or corporate authors. It is not necessary to register a copyright, although important enforcement benefits are conferred by doing so. Copyright registration is the statutory responsibility of the United States Library of Congress.

A trademark or mark is any word, symbol or device that serves to identify the source or origin of particular goods or services. INSOMNIAC GAMES, GRAND THEFT AUTO and PLAYSTATION are examples of famous word marks of Insomniac Games, Inc., Take-Two Interactive Software, Inc., and Sony Computer Entertainment Inc., respectively. Sega Corporation’s classic “Sonic the Hedgehog” graphic character design and Nintendo of America Inc.’s equally famous “Mario the Plumber” graphic character design are examples of widely recognized design trademarks. The white and red stylized GAMESTOP lettering is a combined word and design mark of Gamestop, Inc. The nonfunctional trade dress of a product—the product’s “total image”—is also capable of serving as a trademark. An example is the case design of the Microsoft Xbox 360. Unlike a copyright, a trademark can be obtained for a word or title, as long as the word or title signifies the source of the product or service. For example, the words “star wars” and “Harry Potter” cannot be copyrighted as the title of a single book or film, but they can serve as a trademark for a series of books or films and for merchandise related to the book or film that originates from one source. Moreover, the creative content of the *Star Wars* and *Harry Potter* stories, including the text or screenplay and such subcomponents as characters, costumes, dialogue, scenes, and plot, is protectable by copyright. Ownership of a trademark is established by first use.

It is not necessary to register a trademark to secure exclusive rights but, as with a copyright, registration confers significant benefits. The USPTO registers trademarks, as do the individual states. The federal trademark law is known as the Lanham Act. The duration of a trademark potentially is perpetual. It lasts as long as it is in use to identify the source of goods or services. A federally registered trademark is renewable every 10 years as long as the mark continues in use in interstate commerce.

The foregoing IP categories are by no means mutually exclusive. Take, for example, a game controller named the WIGLI with an unusually sculpted design that incorporates a novel motion sensor. WIGLI serves as a trademark identifying the controller creator as the seller. The WIGLI creator also may be able to claim copyright protection in the controller's shape as a sculpture, apply for a design patent to protect the ornamental features of the controller, and apply for a utility patent on the motion sensor invention. Over time, if the public associates the controller's distinctive design with the source of the controller, as the public has come to associate the curved shape of the Coca-Cola glass bottle with cola originating from Coca-Cola Company, then the controller's shape could be claimed separately as a trademark. This IP overlap is well illustrated in the context of video games.

The IP Content of Video Games

The typical video game is protected by an umbrella of patents, copyrights, trademarks, and trade secrets that may be owned by different parties. Because copyright covers creative expression fixed in a tangible medium, it is the most prevalent form of IP protection in video games. Software in the form of game engines and tools, software documentation, artwork, storyline, backgrounds, characters, costumes, weapons, dialogue, text, sound effects, and music are among the forms of copyrightable expression found in games. Copyright ownership originates with the author or creator. This can be the employee who draws the artwork or an independent contractor who scores the music. Under "work-for-hire" principles later discussed, employee contributions normally become the property of the employer by operation of law. Independent contractors generally must assign their rights in a written agreement to the party who commissions the work. Copyrights are subject to transfer by assignment or license. An assignment conveys all rights to the copyrighted IP. A license conveys less than all of such rights; for example, the nonexclusive, nontransferable, perpetual right to sell the copyrighted work throughout North America. Independent developers typically assign rights to those portions of the game that are experienced by a player to the publisher that funds development of the game. They grant an irrevocable and nonexclusive license to the publisher for the software that enables the game to run. The game may be based on a copyright license, such as when a film, book, or comic is made into a video game.

Patents may apply to the technology embodied in the hardware on which the game is played, on the media (diskette, CD, cartridge, hard drive) on which the game is recorded, and on software that enables the game to perform particular functions.

Hardware patents are owned or licensed by the manufacturer, who also may be the publisher, in the case of Sony, Microsoft, and Nintendo, and at times also the developer of the game. Because patents are expensive to acquire and to enforce, they are rarely sought by independent developers.

Video games also provide a fertile environment for trademarks. The publisher and developer of the game, often separate parties, may each trademark their business name as a word mark and may create a design such as fanciful lettering or a graphic as a further source of their identification. The title of the game may be the separate subject of trademark protection. If a particular feature of the game also acts as a designation of the source of the game, it may function as a trademark. As already mentioned, Sega's adoption of Sonic the Hedgehog as its corporate mascot, Nintendo's similar display of Mario the Plumber, and Sony's *de facto* use of Crash Bandicoot as its mascot in connection with the original PlayStation games, have served as widely recognized brands of these companies.

Lastly, confidential aspects of the know-how used to program the game, budgets and financial statements, and the terms of the agreements between the developer and its publisher, its employees, and its independent contractors, may be secured from use by others as trade secrets. Prior to the release of a much anticipated game to the public, the entire contents of the game may be maintained as a trade secret to build interest and thwart simultaneous-release knockoffs.



John Steele

www.johnsteelelaw.com

John Steele is a solo practitioner in Palo Alto (CA), emphasizing legal ethics, professional liability, and risk management. For over 15 years he served as the chief internal ethics lawyer at at AmLaw 100 and an AmLaw 200 firm. He has been a member of the ABA

Center for Professional Responsibility, the State Bar of California's Committee on Professional Responsibility and Conduct (2005-08), and the Association of Professional Responsibility Lawyers, and he has taught legal ethics for 25 semesters as a Visiting Professor and Lecturer at Stanford Law School, UC-Berkeley School of Law (Boalt Hall), Indian University - Bloomington, and Santa Clara University School of Law.

John Steele, Attorney at Law
IP ETHICS 2010

Topics

- Inequitable Conduct
- Conflicts
- Malpractice
- OED matters
- Odds & Ends

1.
**Inequitable
Conduct**

Ethics Rules

Rule 3.1
Rule 8.4
PTO Ethics Rule 10.23
PTO Ethics Rule 10.89
PTO Practice 1.56

Inequitable conduct

**Therasense
(en banc)**

Data graphics

Christian Mammen
Dennis Crouch

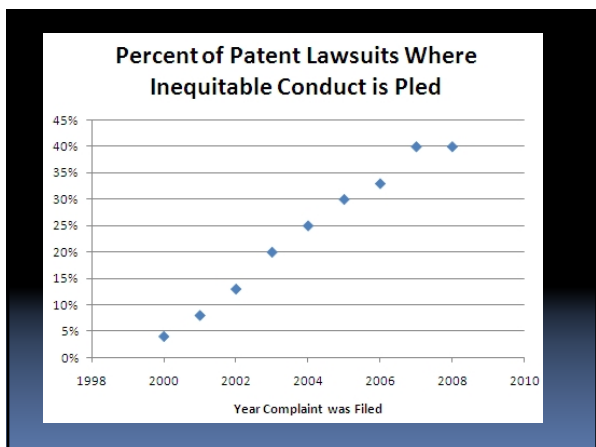
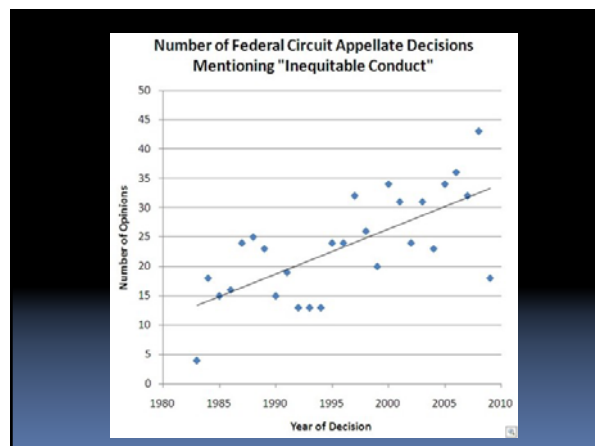
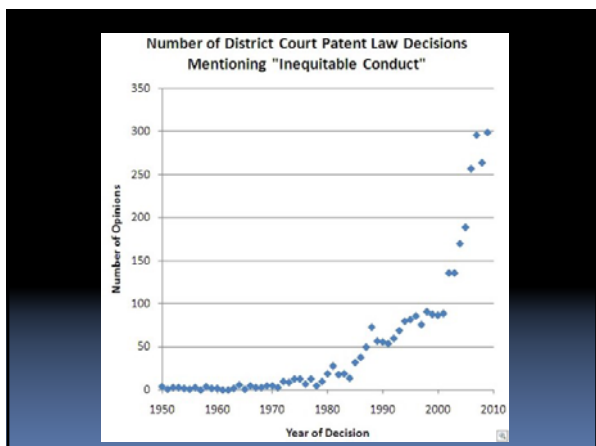

559 F.3d 1317 (Fed. Cir. 2009)

Larson:
 Didn't submit rejection in co-pending case

580 F.3d 1240 (Fed Cir 2009)

In re Bose:
 False Section 8/9 renewal
 Term of art



CAFC (January 25, 2010)

**Therasense:
Inconsistent factual
statements to PTO & EPO**

April 26, 2010

**Therasense:
(decision to hear en
banc)**

2010 U.S. App. LEXIS 8644
(Apr. 27, 2010)

**Avid:
Trade show demo
Who has candor duty?**

**2.
Trial & Litigation
Misconduct**

Ethics Rules

**MR 3.1; 3.3; 3.4; 3.5
FRCP 11
PTO 10.23, 10.89**

(E.D. Tex. July 2009; News)

**O2 Micro
v.
Beyond Innovation**

Too clever questioning

[do you] have a problem with a company [located] on a Carribean island ... to avoid ... taxes?



CV 0-404-JJF-LPS (D. Del. May 4, 2009)

St. Clair v. Palm, Inc.

Fed Cir 2010

i4i Ltd P'ship v. Microsoft

<http://www.ediscoverylaw.com/uploads/file/Qualcomm%20Sanctions%20Order.pdf>

Qualcomm II (disaggregation; e-discovery; supervision; liability for co-counsel)

News; (E.D. Tex May 2010)

Commil USA v. Cisco

Disaggregated Legal Work



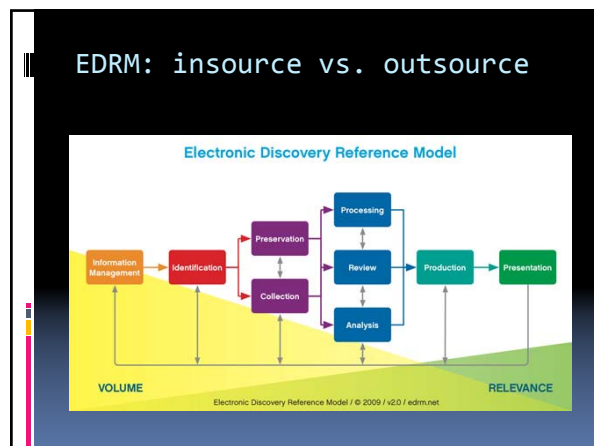
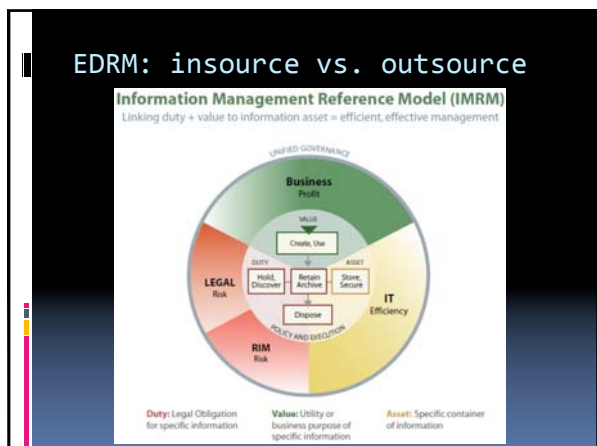

3. Conflicts

Ethics Rules

MR 1.7, 1.9, 1.10
PTO 10.66
CRPC 3-310

3(a) Current Clients

Ethics Rules

MR 1.7
PTO 10.66
CRPC 3-310

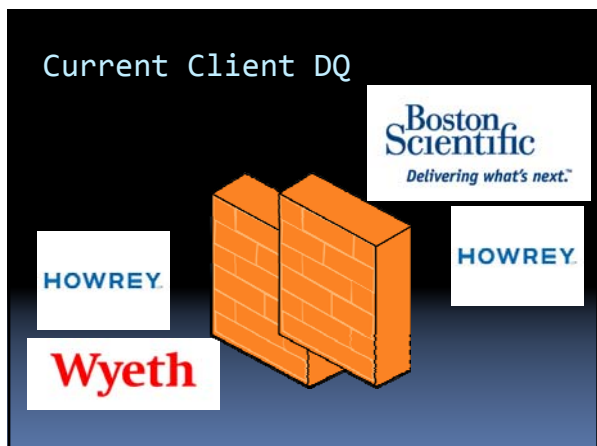

citations

- 647 F. Supp 2d 369 (D. Del. 2009)
- 2010 U.S. Dist. LEXIS 11032 (D.N.J. Feb. 8, 2010)

3(b)
Client Identity

Ethics Rules

MR 1.2
MR 1.7
PTO & California
case law

Client Identity: 2010 U.S. Dist.
LEXIS 48333

E2Interactive
v.
Blackhawk

Client Identity
670 F. Supp. 2d 201 (SDNY 2009)

Merck
v.
Prothera
(DQ granted)

A photograph of a church sign for "FIRST BAPTIST CHURCH" with a white cross. To the right of the cross, it lists "WORSHIP 8:30am 10:30am" and "BIBLE STUDY 8:30am 10:30am". Below the church sign is a white sign with the text "NO MAN CAN SERVE TWO MASTERS LUKE 16:13". A URL "www.says-it.com/churchsigns/" is visible above the bottom sign.

Client Identity; 2009 U.S. Dist. LEXIS 109641 (N.D. Cal. November 9, 2010)

Skyy Spirits
v.
Ruby
(no DQ)



Client Identity: 2009 U.S. Dist. LEXIS 14609 (D.N.J. Feb. 25, 2009)

FMC
v.
Guthery
(no DQ)



3(c)
Former Clients

Ethics Rules

MR 1.9
PTO 10.66
CRPC 3-310(E)

Former Client conflicts

- "Same or substantially related"
- Flexible term of art
- Is all IP the same?



Former Client conflicts

- Openwave ©
- Genentech ©
- Halladay ©



Citations; DQ granted

Openwave, 2010 U.S. Dist. LEXIS 49628
(N.D. Cal., April 22, 2010)
Genentech, 2010 U.S. Dist. LEXIS 35867
(N.D. Cal., March 20, 2010)
Halladay, 2009 U.S. Dist. LEXIS 97040
(C.D. Cal., October 5, 2009)
Apeldyn, 2010 U.S. Dist. LEXIS 22942 (D.
Del., March 12, 2010)

Former Client conflicts

Graham TM
Fabric Select. ©
Revise TM
Soverain ©



citations

Graham, 2009 U.S. Dist. LEXIS 103222 (E.D. Pa.,
November 3, 2009)
Fabric Selection, 2009 U.S. Dist. LEXIS 111329
(C.D. Cal., November 17, 2009)
Revise Clothing, 2010 U.S. Dist. LEXIS 12766
(S.D.N.Y., February 1, 2010)
Soverain Software, 2010 U.S. Dist. LEXIS 26162
(E. D. Tex., March 18, 2010)

3(d)
Experts

Expert Cases

In re Mentor, 2010 U.S. Dist. LEXIS 32606
(M.D. Ga. April 1, 2010)(DQ denied
where expert was formerly opponent's
employee)
Outside the Box, CAFC (2009-1171, -1558;
February 1, 2010)(DQ granted; law firm
partner offered expert declaration; then
the firm commenced representation
adverse to declaration's proponent)

3(e)
Prosecution Bar

Prosecution Bar

In re Deutsche Bank (CAFC; May 27, 2010)

4. Malpractice

Ethics Rules

MR 1.1, 1.3, 1.7-10
PTO 10.77
CRPC 3-110

Alleged mistakes/results

Fraud on client after botched filings (Landmark, 2009 US Dist LEXIS 6672)
Technology too close (Gurvey, 2009 US Dist LEXIS 3483)

Alleged mistakes/results

No proof of market for product; sj granted (Maatuk, 173 Cal App 4th 1191 (2009))
Over optimistic about claim (Larson & Larson, 22 So. 2d 36 (2009))
Enmeshed in co-owner dispute (Max Planck, 661 F. Supp. 2d 125 (2009); Blaustein, 2009 US Dist LEXIS 83484 (Sept. 11, 2009))
Forced client to settle (Copyright & trademark, Cassel, 179 Cal App. 4th 152 (2009))

Alleged mistakes/results

Maintenance fee (Tattle Tale; E.D. Pa., November 3, 2009)
Didn't name defendant's president or look at collectibility (Randall Curtis Wotring, 2009 US Dist LEXIS 63668)
Misadvised client about strength of copyright ownership claims (Katz, 2009 US Dist LEXIS 10721)
Poor drafting of patent (Weather Central, 2009 US Dist LEXIS 9910)

News accounts

\$70 million verdict

Akin Gump

585 F.Supp.2d 995 (N. D. Ill. 2008)

Parus

v.

Banner Witcoff

Accuweb v. Foley Lardner

Accuweb

v.

Foley & Lardner

2008 WL 2908912

Singh

v.

Duane Morris

News accounts

Ecast

v.

Morrison & Foerster

593 F.Supp.2d 1153 (S.D. Cal. 2008)

Vaxiion

v.

Foley & Lardner

No. 1-08-0985 (Ill. App. 1st Dist.
June 18, 2009)

Learning Curve
v.
Seyfarth Shaw

News accounts

Warrior Sports, Inc.
v.
Dickinson Wright

News accounts

Landmark
v.
Morgan Lewis

Client Identity Issues

Mindy's Cosmetics, Inc.
v.
Dakar

2010 U.S. App. LEXIS 13734
(Ninth Circuit; July 6, 2010)

POA; Client Identity

Memorylink Corporation
v.
Motorola, Inc.

2010 U.S. Dist. LEXIS 81877
(N.D. Ill.: August 6, 2010)

Missed Deadlines US & Japan

GENELINK BIOSCIENCES, INC.
v.
COLBY (Duane Morris LLP)
2010 U.S. Dist. LEXIS 66177 (D.N.
J.; July 1, 2010)

Substandard litigation

SIRF TECHNOLOGY INC., Plaintiff,
v.
ORRICK HERRINGTON AND SUTCLIFFE LLP,
Defendant.

2010 U.S. Dist. LEXIS 62404 (N.D. Cal. 2010)
June 22, 2010, Filed

Causation; Patentability

Davis

v.

Brouse McDowell, LPA
596 F.3d 1355 (Fed. Cir. 2010);
2010 U.S. App. LEXIS 4266; 93
U.S.P.Q.2D (BNA) 1917

Technology too close; identical language in app

TETHYS BIOSCIENCE, INC., Plaintiff,
v.
MINTZ, LEVIN, COHN, FERRIS, GLOVSKY
AND POPEO, P.C. and IVOR R. ELRIFI,
Defendants.

2010 U.S. Dist. LEXIS 55010 (N.D. Cal. 2010)
June 4, 2010, Filed

Malicious prosecution; trademark;
Diana, Princess of Wales

FRANKLIN MINT COMPANY

v.

MANATT, PHELPS & PHILLIPS, LLP
184 Cal. App. 4th 313; 109 Cal. Rptr. 3d
143; 2010 Cal. App. LEXIS 606 (May 3,
2010)

Client ID; family business

SAFE FLIGHT INSTRUMENT CORPORATION
v.
RICHARD A. SPORN, ESQ., et al.
SUPREME COURT OF NEW YORK, NEW YORK
COUNTY

2010 NY Slip Op 31397U; 2010 N.Y. Misc. LEXIS
2175 (June 7, 2010)

5.
PTO/OED
Discipline



Dan Burk

Dan L. Burk is Chancellor's Professor of Law at the University of California, Irvine, where he is a founding member of the law faculty. An internationally prominent authority on issues related to high technology, he lectures,

teaches, and writes in the areas of patent, copyright, electronic commerce, and biotechnology law. He is the author of numerous papers on the legal and societal impact of new technologies, including articles on scientific misconduct, on the regulation of biotechnology, and on the intellectual property implications of global computer networks.

Prior to his arrival at UCI, Professor Burk taught at the University of Minnesota Law School. He previously held teaching positions at Seton Hall University and Stanford Law School. He has also taught as a visitor at a variety of prominent institutions, including Cornell Law School, the University of California at Berkeley, the University of Toronto, University of Tilburg, the Munich Intellectual Property Law Center, and the Università Cattolica del Sacro Cuore in Piacenza, Italy.

Professor Burk holds a B.S. in Microbiology (1985) from Brigham Young University, an M.S. in Molecular Biology and Biochemistry (1987) from Northwestern University, a J.D. (1990) from Arizona State University, and a J.S.M. (1994) from Stanford University.

He has served as a legal advisor to a variety of private, governmental, and intergovernmental organizations, including the American Civil Liberties Union Committee on Patent Policy, the OECD Committee on Consumer Protection, and the United States State Department Working Group on Intellectual Property, Interoperability, and Standards.

Tailoring Patent Law

to Promote Innovation

Dan L. Burk
University of California, Irvine

Unitary Patent System

- *Diamond v. Chakrabarty*
 - Patentable subject matter
 - Living organisms
 - “anything under the sun”
- *Harvard College v. Commissioner*
 - Identical statutory language
 - Opposite legislative intent
- Default Rules

Patent Reform

- Remedies
- Post-grant Review
- Inequitable Conduct
- Best Mode Requirement
- Harmonization
- Industry Opposition
- Pharma v. IT

Innovation Profiles

- Research & Development
 - Innovation costs
 - Product life cycles
 - Incremental improvement
- Product Characteristics
 - Unitary inventions
 - Multiple inventions
 - Freedom to operate

Industry Practice

- Entrepreneurs
 - Biotech & health
 - Information technology
 - Venture capital backing
- Strategic Patenting
 - “Patent flood”
 - Stockpiling
 - Enforcement
- Prosecution Practice

Economic Models

- Arrowian Innovation
- Incremental Innovation
- Schumpeterian Innovation
- Prospect Theory
- Patent Thickets
- Anti-Commons

Specialized Statutes

- Semiconductor Chip Protection Act
- 35 USC §103(b)
- Plant Variety Protection Act
- EU Database Directive

Specialized Statutes II

- Statutory Obsolescence
 - Technological change
 - Market change
- Special Interest Legislation
 - Legislative capture
 - Unanticipated outcomes

Non-Specific Statutes

- General Application
- “Policy Levers”
 - Adaptable provisions
 - Case-by-case
 - Fact specific
- Categorical Outcomes
- Anti-Trust Statutes

The PHOSITA

- Obviousness
- Disclosure
- Definiteness and elsewhere
- “Art” Specificity
- Modulates legal standard

Rules & Standards

- Rules
 - Binary
 - Bright-line
 - “Crystals”
- Standards
 - Flexible
 - Fact-specific
 - “Muddy”

Rules & Standards II

- Temporal Imperatives
 - *Ex ante*
 - *Ex post*
 - Information acquisition
- Institutional Imperatives
 - Decision makers

Institutional Competence

- **Legislature**
 - Political capital
 - Public choice
- **Administrative Agencies**
 - Expertise
 - Capture
- **Courts**
 - Independent judiciary

eBay v. Mercexchange

- **Permanent Injunctions**
 - Equitable factors
 - Irreparable injury
 - Balance of hardships
 - Public interest
- **Information Technologies**
 - Non-practicing entities
 - Monetary damages

In re Fisher

- **DNA Patenting**
 - Expressed Sequence Tags
 - Partial DNA sequences
 - Laboratory tools
- **Utility Doctrine**
 - Bare utility
 - Practical utility
 - Gene “function” (gene product)

Judicial Response

- **“Judicial Activism”**
 - Judicial “legislation”?
 - “Kabuki confirmation”
 - Disregarding legislative intent
- **Judicial Responsibility**
 - Implementing statutes
 - Context sensitivity

Thank You

Questions Welcome

Instead of legislation, Congress should let the courts continue to resolve the patent crisis.

Courts and the Patent System

BY DAN L. BURK

University of California, Irvine

AND MARK A. LEMLEY

Stanford Law School

The patent system is in crisis. The consensus in favor of strong patent protection that has existed since the 1982 creation of the Federal Circuit (the appeals court that hears virtually all patent disputes in the United States) has broken down. Patent owners — and the Federal Circuit itself — are beset on all sides by those complaining about the proliferation of bad patents and the abuse of those patents in court. Critics point to example after example: silly patents granted by the Patent and Trademark Office (PTO), lawsuits filed by people who invented something decades ago against companies who do something very different today, patent claims so confusing that no one can be sure what the patent covers, and so on.

But the patent system described above — the one in crisis — is not the only patent system in the United States. There is another system in which claims are clear, patents are subject to significant scrutiny, and strong protection is necessary to allow companies to recover hundreds of millions of dollars in investment. The prototypical industry that operates in this second patent system is the pharmaceutical industry, but other industries, including medical devices and chemistry, look more like this as well.

Talk to lawyers or businesspeople at technology companies about the patent system and you will quickly get a sense of our two different patent systems. In the pharmaceutical industry, there seems to be a strong consensus (at least among inno-

vative rather than generic pharmaceutical companies) that patents are critical to innovation. Their only complaint is that patents aren't strong enough. They don't last long enough to compensate for delays in the drug approval process, and the uncertain or probabilistic nature of patent scope and validity leaves them with uncertain protection for their enormous investment.

Lawyers and executives in the information technology (IT) industries, by contrast, almost invariably see the patent system as a cost rather than a benefit to innovation. Even IT companies with tens of thousands of patents generally use those patents only "defensively," to minimize the amount they must pay other patent owners to permit them to sell their products. Ask most of those companies, and in their candid moments they will tell you that they would be better off without any patent system, or at least with one that was radically changed and that left them alone to innovate.

INNOVATION DIFFERENCES

Any doubts that the patent system is perceived by different industries in fundamentally different ways were dispelled during the past five years of congressional debate over patent reform. Different industries calling for reform couldn't agree on a single principle of reform. The pharmaceutical and biotech industries wanted harmonization on first-to-file, the elimination of the best-mode requirement, and the weakening of rules against inequitable conduct, but those changes were opposed by the IT industry. The IT industry wanted reforms to limit damages and injunctive relief in patent holdup settings and an effective administrative process to oppose patents, but those reforms were opposed by the biomedical industries.

In the last 20 years, legal and economic scholarship has pro-

Dan L. Burk is Chancellor's Professor of Law at the University of California, Irvine. **Mark A. Lemley** is the William H. Neukom Professor of Law at Stanford University and a partner at Durie Tangri LLP.

This article is excerpted from their new book, *The Patent Crisis and How the Courts Can Solve It* (University of Chicago Press, 2009).

vided valuable evidence about the complex process of innovation and how the patent system affects innovation. Rather than resolve the debate over how well the patent system works, however, this evidence has painted a more complex picture. Different industries vary greatly in how they approach innovation, the cost of innovation, and the importance of innovation to continued growth. One size definitely does not fit all. This observation is graphically illustrated by examples from several industries, whose characteristics we sketch here.

First, the cost of research and development varies widely from industry to industry and from innovation to innovation. In the pharmaceutical industry, for example, the research and development, drug design, and testing of a new drug can take a decade or more and cost, on average, hundreds of millions of dollars. Some — probably most — of this cost is a result of the labyrinthine regulatory process and the detailed study that is required to determine that a drug is safe and effective for humans so the Food and Drug Administration will approve it. A major additional part of the cost stems from the uncertainty of the research and development efforts.

Pharmaceutical companies may try hundreds of compounds before identifying a possible drug, and they may not know for years whether they have chosen the right one for testing. Drug companies need some way to get a return on that significant investment.

Another example of an industry where invention requires significant investment is semiconductors. As microprocessors have gotten smaller, their design as well as the facilities and processes used to create them have grown exponentially more complex. Building a new microprocessor requires not only painstaking work on circuit design — work that can cost tens of millions of dollars — but also the design and construction of an entirely new fabrication process in a new facility. The need for both highly skilled labor and a dedicated physical plant makes microprocessor development highly resource-intensive. Ultimately, the design of a new generation of microprocessors takes years of planning and construction and can cost more than \$4 billion.

By contrast, other industries require significantly less investment in research and development. In the software industry,

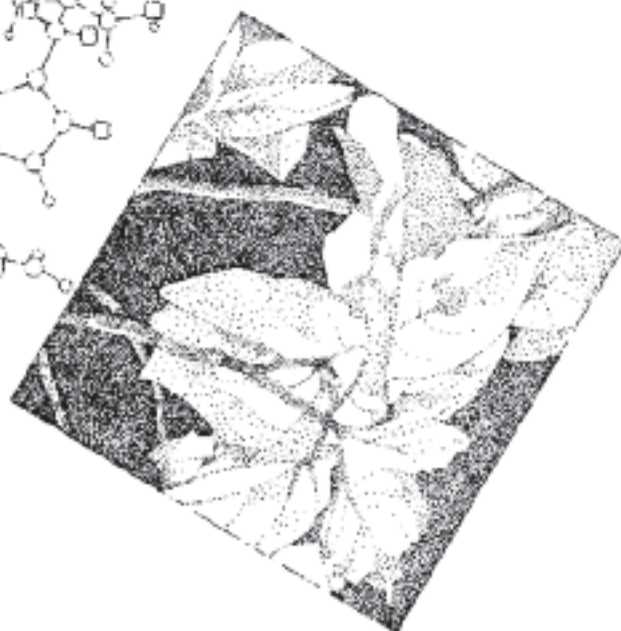
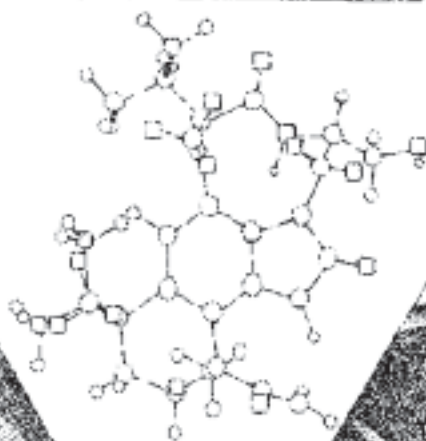
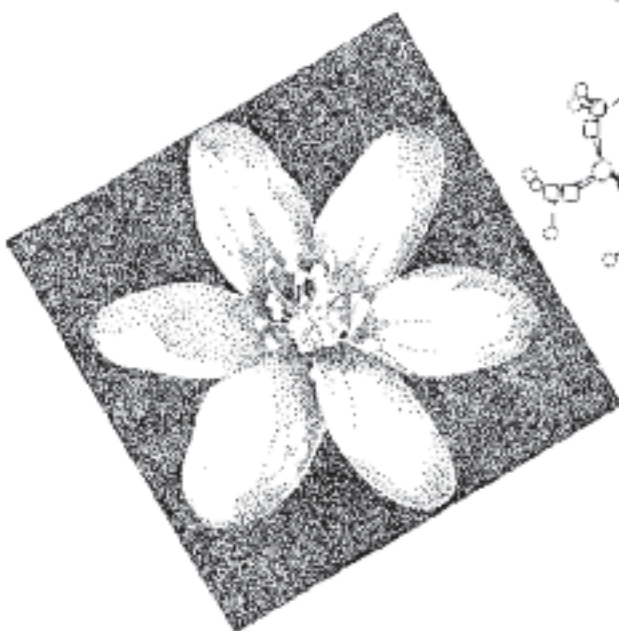

for example, it has long been possible for two programmers working in a garage to develop a commercial software program. The cost of writing code has gone up in recent years, particularly for operating systems. Operating systems tend to be more complex than applications programs because operating systems must be written to run a variety of computer programs and control various hardware devices. But it is still possible in many cases to hire a team of programmers to write a new applications program for less than \$1 million. Although debugging a new program is still a significant undertaking, writing such a program takes considerably less time than developing a new drug or producing a microprocessor.

Further, in software and many other industries, particularly biotechnology and the manufacture of machines and consumer products, much of the innovation process has been automated in the last 15 years. Although computer-assisted design and manufacturing tools do not replace the need for innovative ideas, they make the process of prototyping and testing those ideas much easier and faster. Similarly, powerful bioinformatics databases and the development of mass-production techniques like polymerase chain reaction have revolutionized the biotechnology industry, making the identification of gene sequences and the development of related therapies much cheaper and quicker than they were in preceding decades. The use of automated tools that actually generate sections of code to help design simple programs such as websites has made computer programming simpler. The result of this automation is that industries in which traditional innovation was largely an iterative process of optimizing prototypes today require less research and development expenditure than those that require either live testing or a new manufacturing process.

Economic evidence has also shown industry-specific variation in the corporate nature of innovation. The prototypical innovation contemplated by the patent law is made by an individual inventor working in his garage after hours. But innovation in most industries today is generally collaborative and much of it requires large laboratories. The overwhelming majority of patents today are granted to large corporations, and even those granted to individuals and small corporations are often incubated in large research universities. The role of individual inventors is much greater in some industries, such as mechanics and software, than in others, such as biotechnology and semiconductors. And not surprisingly, corporate innovation tends to cost more than innovation by individuals.

DIFFERENCES IN PATENTING PRACTICE

The systematic variation in research and development expenditures across industries naturally affects the need for patent protection. Industries that must spend more time and money in research and development generally have a greater need for patent protection in order to recoup that investment. That doesn't mean that the patent system has no place for cheaper inventions; patents may still facilitate market transactions in new innovations. But certain industries have a stronger claim than others to need the incentives patents provide.

The effective scope of patents that do issue also varies

tremendously by industry. This variance results from the relationship between a patent and a product. Much conventional wisdom in the patent system is built on the unstated assumption of a one-to-one correspondence in which a single patent covers a single product. For example, we speak of patents covering products: in common parlance, Eli Whitney patented the cotton gin, Thomas Edison patented the light bulb, Alexander Graham Bell patented the telephone, and the Wright brothers patented the airplane. Modern patent law also assumes such a one-for-one correspondence in its decision to measure damages by the profits lost in the sale of infringing products.

However, such a correspondence is the exception rather than the rule in the modern economy. Machines of even moderate complexity are composed of many different pieces, and each of those components can itself be the subject of one or more patents. No inventor could patent a modern car, for instance. Rather, he would be required to patent a particular invention — say, intermittent windshield wipers — that is only one small piece of a much larger product. This correspondence may have been overstated even in the classic inventions mentioned in the last paragraph: the Wright brothers did not in fact patent an aircraft; their patent actually covered the use of a vertical rudder and a fixed wing (the “aeroplane”). Edison's patent was an improvement on an existing light bulb that claimed a particular class of incandescent filaments. Still, the traditional mechanical nature of invention was more susceptible to the one patent–one product correspondence than the more complex modern environment.

The strength of this correspondence varies by industry. In some industries such as chemistry and pharmaceuticals, a single patent normally covers a single product — a new chemical or a new use for that chemical. In industries such as semiconductors, by contrast, new products are so complex that they can incorporate hundreds and even thousands of different inventions — inventions frequently patented by different companies. A patent covering one of those hundreds of components will not effectively protect the product; it is useful, if at all, only as a licensing tool. Further, this difference means that we cannot simply apply the remedy rules from one industry to patents in another; if damages are calculated correctly, patents in the semiconductor industry will tend to generate much lower royalty rates than in the single-patent product industries. Mark Lemley and Carl Shapiro, in a 2007 *Texas Law Review* paper, offer evidence that courts do not fully take these differences into account, but they still find industry-specific variation in royalty rates. Still other industries fall somewhere in between. Products in biotechnology or software may require the integration of several different patents, but not hundreds of them. The correspondence between patents and products obviously affects the significance of patents in protecting research and development.

Industries differ in the importance of continued innovation. Innovation is, in general, socially valuable. In many industries, especially young ones, innovation is critical to welfare. But innovation works very differently in different industries. In some industries, notably pharmaceuticals, inno-

vation tends to be a stand-alone process generating a single finished product. Once a drug is developed and tested, it tends not to be improved. At most, pharmaceutical companies will improve the delivery system or patent obvious chemical variants such as metabolites. By contrast, in computer software, cumulative innovation is extraordinarily important. It is received wisdom among software consumers that you shouldn't buy version 1.0 of any program. The expectation is that the programs will be incrementally improved over time. These differences in innovation have great significance for patent policy because they bear on the importance we should attach to pioneer innovation in various sectors as opposed to continuing improvement.

The relationship between patents and innovation is at least as complex as the profile of technological and economic factors that determine innovation. There is no simple or universal correlation between the availability of patents and the incentive to innovate. Indeed, as the American Enterprise Institute's Bob Hahn has put it, "the most general lesson to be gleaned from the patent literature is that there are few general lessons." This is due in part to the fact that the patent system interacts with industries at several different points in the innovation process. Recent evidence has demonstrated that this complex relationship is industry-specific at each stage of the patent process: deciding to seek protection, obtaining a patent, setting the scope of a patent, deciding to enforce a patent, and determining litigation outcomes.

Rewriting the patent law for each industry would involve substantial administrative costs and uncertainty. Congress would have to write new statutes not just for biotechnology and software, but for numerous different industries with special characteristics. Semiconductors, pharmaceuticals, chemicals, nanotechnology, telecommunications, and other industries would all need separate statutes. Past experience with such specialized statutes is also not encouraging. The history of industry-specific statutes suggests that many fail because they are drafted with then-current technology in mind and are not sufficiently general to accommodate the inevitable changes in technology.

PATENT POLICY LEVERS

The need for industry-specific statutory tailoring implicates the broader question of legal generalization versus particularization, of which the issue of rule-based or standards-based decision making is, perhaps paradoxically, a particular instance. Law necessarily contains general prescriptions for governing behavior, prescriptions that may fit particular instances well or poorly. Where the fit is poor, it may be sensible to equip decision makers with discretion to tailor the general prescription. The patent statute equips courts with precisely such discretion via a series of doctrinal "policy levers" that allow patents to be calibrated to the needs of particular industries.

For example, a number of factual questions in patent law are answered from the perspective of the "person having ordinary skill in the art" (PHOSITA). Much of the case law concerning the PHOSITA arises out of the consideration of the

obviousness standard found in § 103 of the patent statute. Although originally developed as a common law doctrine, the non-obviousness criterion was codified in the 1952 Patent Act as a requirement that the claimed invention taken as a whole not be obvious to one of ordinary skill in the art at the time the invention was made. The PHOSITA is equally central to calibrating the legal standard for patent disclosure. In return for a period of exclusive rights over an invention, the inventor must fully disclose the invention to the public. The first paragraph of § 112 requires that this disclosure enable "any person skilled in the art" to make and use the claimed invention. This same standard controls several other disclosure doctrines as well. First, the definition of enablement affects the patentability requirement of specific utility, as the invention must actually work as described in the specification if the inventor is to enable one of ordinary skill to use it.

As the name suggests, PHOSITA-based analysis is specific to the particular art in which the invention is made. Courts measure most significant patent law doctrines against a benchmark that varies by industry, and within industry by technology. If the court concludes that an art is uncertain and its practitioners are not particularly skilled, it will be inclined to find even relatively modest improvements non-obvious to the PHOSITA. At the same time, the court will be inclined to require greater disclosure to satisfy the requirements of § 112, and correspondingly to narrow the scope of claims permissible from any given disclosure. If the art is predictable and the PHOSITA quite skilled, the reverse is also true. The result is to make the PHOSITA a potentially significant macro policy lever, awarding many narrow patents to some industries and a few broader patents to other industries.

There is overwhelming evidence that the application of the PHOSITA standard varies by industry, leading for example to fewer but broader valid software patents, and more but narrower biotechnology patents. It is less clear that the court is in fact using the PHOSITA explicitly as a policy lever, responding to the characteristics of particular industries, rather than merely trying to predict what those of skill in the art would think.

In 2007, the Supreme Court changed the standard of obviousness in the *KSR* case. Rather than focus on the existence of a written suggestion in the prior art, the Court said, the test for obviousness must focus on the knowledge and abilities of the PHOSITA, including whatever creative or innovative tendencies the ordinary scientist in the field possessed. In one fell swoop, the Court turned obviousness from a search for written suggestions in the prior art, regardless of industry, to a question of what the PHOSITA in a particular field would know or could figure out. In so doing, *KSR* gave courts the power to use obviousness doctrine as a whole as a case-by-case policy lever, one that will lead to more valid patents in industries in which the PHOSITA knows little or is uncreative, and more invalid patents in industries with more sophisticated players.

EMERGING POLICY LEVERS

Patent rights are exclusive rights that fit the classic formulation of a "property rule." Indeed, the patent right to exclude

was regarded by the Federal Circuit as a nearly absolute property rule, and the assumption that a finding of patent infringement will be accompanied by an injunction was almost universal from the mid-1980s until 2006. In fact, however, the patent statute provides only that courts may grant injunctive relief, not that they must.

The legal standard for *preliminary* injunctive relief has vacillated over time. Preliminary injunctions were virtually impossible to obtain before the creation of the Federal Circuit. The Federal Circuit substantially liberalized the standard for granting such injunctions in the 1980s, but then tightened it considerably in the 1990s, to the point where today preliminary injunctions are quite rare. The court has the discretion under the statute to do something similar with permanent injunctive relief. In copyright cases, as opposed to patent cases, the Supreme Court has on several recent occasions encouraged the lower courts not to grant injunctive relief as a matter of course.

On rare occasions before 2006, courts in patent cases refused to grant permanent injunctive relief, for example in cases where courts found a strong public policy interest in continued access to the invention. This suggests that injunctive relief can serve as a policy lever by industry or on a case-by-case basis. Courts could deny injunctive relief in some industries altogether. Some consumer advocates suggest that life-saving drugs ought to fit into this category, for example. Alternatively, courts could deny injunctive relief on a case-by-case basis depending on other characteristics that differ by industry, such as whether the plaintiff actually practices the invention.

We recently witnessed the creation of a policy lever in real time. In its 2006 decision in *eBay v. MercExchange*, the Supreme Court rejected the longstanding rule that patentees who won their cases were automatically entitled to an injunction shutting down the infringing product. Relying on the statutory language and common-law principles of equity from outside patent law, the Court held that the decision whether to enjoin a defendant's product must be made on a case-by-case basis after considering four (really three) factors:

- Will the plaintiff suffer irreparable injury without an injunction, or is there an adequate remedy at law?
- Will the hardship to the defendant from granting an injunction outweigh the hardship to the plaintiff from denying the injunction?
- Where does the public interest lie?

The Court emphasized that those determinations should be on the basis of individual facts, not rigid rules or tests.

Dozens of district courts have applied those standards in the past two years. Despite the case-by-case nature of the inquiry, the district court opinions have established some general rules. Patentees who compete in the market essentially always get injunctions under the four-factor test, because it is extremely difficult to determine what would have happened in a counterfactual world in which the patentee actually had market exclusivity. Hence, damages are unlikely to be adequate as a remedy for the lost market share that infringe-

ment causes. In contrast, patentees that do not participate in the market, but merely seek to license their patent to those who do, can almost never satisfy the four-factor test because by definition what they want is money damages in the form of a reasonable royalty. Further, almost all of the non-practicing entity cases arise in complex technology industries in which the patent covers only a small component of the larger product. In those cases, the balance of the hardships strongly favors the defendant because an injunction will shut down not merely the infringing technology, but a much larger set of non-infringing technologies attached to it. There is only one exception so far to this general rule that practicing entities get injunctions and non-practicing entities don't: an aberrational Texas district court opinion that held that special rules should apply to nonprofit entities.

This developing distinction operates as a policy lever. While practicing and non-practicing entities exist in every industry, the reality is that in some industries such as pharmaceuticals, the patentees are almost all practicing entities, while in the IT industries a high percentage of patent plaintiffs are non-practicing entities, sometimes called "trolls" for the practice of hiding under a bridge and popping up to demand a toll from surprised passersby. A rule that practicing entities generally get injunctions while non-practicing entities generally do not has dramatically different effects in the pharmaceutical and IT industries. Coupled with apportionment of patent damages, a rule that limits injunctions to plaintiffs that really need them has the potential to help solve the problems with abuse of the patent system while preserving a strong property rule entitlement for those who really need it.

INSTITUTIONAL ROLES

The fact that courts proved capable of solving many of the problems on which new legislation has repeatedly foundered suggests that policy levers, not industry-specific legislation, may be the most effective way of dealing with problems in the patent system. Sen. Patrick Leahy (D-Vt.), discussing the most recent efforts at patent law reform, recently remarked that Congress cannot leave reform to the courts because "Congress writes our laws." But even though Congress undoubtedly makes the laws, frequently the best way to make those laws work is to write them so that the details of their application are delegated to the courts.

Skeptics of the judicial approach might rightly observe that litigation is not cost-free, that judicial expertise is bounded, and that appellate courts in particular are not entirely immune from problems of public choice. However, all advantages are comparative and the question is not whether courts are the perfect statutory tailors, but whether we are better off with no tailoring at all. If we're not, then given the risks of industry-specific statutes described above, we must ask if the courts are better situated to engage in tailoring than are legislatures. The likelihood that a unitary, unvarying, and monolithic statute could supply the correct level of incentive to so many diverse industries with divergent incentives is essentially nil. The prospect of the legislature continually revisiting the

circumstances of each industry and passing appropriate new legislation for each situation is equally bleak. In democratically elected legislatures, an enormous commitment of political capital is typically required to draft, promulgate, and reach consensus on new intellectual property legislation, especially if the legislation is to be supported by credible fact-finding and reliable expertise. We can anticipate serious legislative investigation of, and response to, specialized industry needs to be relatively rare and potentially counterproductive when it does occur.

This is not to say that there cannot be a carefully modulated adjunct role for an agency — in this case, the Patent and Trademark Office — to play in statutory upkeep. But the PTO by design sees only one piece of the patent puzzle: the question of whether a patent should issue in the first place. It never sees infringement disputes, or licenses, or has to allocate remedies. As a result, even if we thought the PTO were best suited to setting industry-specific standards for determining patent validity, there is no reason to believe the PTO staff has any comparative advantage in deciding many of the most important questions of patent law. The PTO may be best suited to creating rules that govern practice before the office itself, such as the information applicants must submit or the ability of applicants to use continuation applications. Most particularly, there may be such a role if the agency can be held to what it does best, which is fact-finding, without becoming involved in setting legal standards, which is the strong suit of the courts. But it is a far cry from application of the PTO's fact-finding expertise to the sort of dynamic interpretation of legal rules with which courts have experience, and which we suggest the patent system needs.

“Wait a minute!” some readers might object. “Aren't you arguing for judicial activism?” Not so. If “judicial activism”

means anything beyond a conclusory label suggesting that the speaker disagrees with the court decision, it refers to courts usurping the role of Congress, generally by invoking the Constitution to strike down congressional statutes. We are suggesting something different. Within the framework created by Congress, there remain a large number of issues to be determined, and it is the proper job of the courts to resolve those disputes. That much has been uncontroversial since *Marbury v. Madison* was decided in 1803. The question is how courts are to resolve those issues in the absence of congressional guidance and subject to legislative veto. We think it makes sense for courts in that position to take account of the realities of the modern patent system. And foremost among those realities is that our unitary patent law confronts an amazing diversity of industry needs and experience. For courts to ignore that diversity in setting the rules it necessarily must set strikes us as foolish.

CONCLUSION

Both innovation and patent law unquestionably work differently in different industries. The law can either take account of those differences or seek to ignore them. Ignoring them would require major changes in existing law. It would also leave the law ill-equipped to deal with the fundamentally different ways in which innovation works in different industries. Indeed, given the crisis of confidence the system currently faces, it is not much of an exaggeration to say that the patent system must bend or break: a patent system that is not flexible enough to account for these industry differences is unlikely to survive, let alone accomplish its stated goals. We believe the system has the flexibility to do both, but this will require the courts to recognize and use the policy levers they have been given. R

Readings

- *Against Intellectual Monopoly*, by Michele Boldrin and David K. Levine. Cambridge University Press, 2006.
- “Consulting PHOSITA,” by Rebecca Eisenberg. *Berkeley Technology Law Journal*, Vol. 19 (2004).
- “Engaging Facts and Policy: A Multi-Institutional Approach to Patent System Reform,” by Arti K. Rai. *Columbia Law Review*, Vol. 103 (2003).
- “How Valuable Is Patent Protection? Estimates by Technology Field,” by Mark Schankerman. *RAND Journal of Economics*, Vol. 29 (1998).
- *Innovation and Its Discontents: How Our Broken Patent System Is Endangering Innovation and Progress, and What to Do About It*, by Adam Jaffe and Josh Lerner. Princeton University Press, 2004.
- “On the Complex Economics of Patent Scope,” by Robert P. Merges and Richard R. Nelson. *Columbia Law Review*, Vol. 90 (1990).
- “Optimal Patent Length and Breadth,” by Richard Gilbert and Carl Shapiro. *RAND Journal of Economics*, Vol. 21 (1990).
- *Patent Failure: How Bureaucrats, Judges, and Lawyers Put Innovators at Risk*, by James Bessen and Michael J. Meurer. Princeton University Press, 2008.
- “Patent Holdup and Royalty Stacking,” by Mark A. Lemley and Carl Shapiro. *Texas Law Review*, Vol. 85 (2007).
- “Patents and Innovation: An Empirical Study,” by Edwin Mansfield. *Management Science*, Vol. 32 (1986).
- *Patents in the Knowledge-Based Economy*, edited by Wesley M. Cohen and Steven A. Merrill. National Academies Press, 2003.
- “Research and Development with Asymmetric Firm Sizes,” by Richard J. Rosen. *RAND Journal of Economics*, Vol. 22 (1991).
- “Rethinking Patent Law in the Administrative State,” by Orin S. Kerr. *William and Mary Law Review*, Vol. 42 (2000).
- “Standing on the Shoulders of Giants: Cumulative Research and the Patent Law,” by Suzanne Scotchmer. *Journal of Economic Perspectives*, Vol. 5 (1991).
- “The Determinants of Patenting in the U.S. Semiconductor Industry, 1980–1994,” by Bronwyn H. Hall and Rosemarie Ziedonis. *RAND Journal of Economics*, Vol. 32 (2001).
- “The Growing Complexity of the United States Patent System,” by John R. Allison and Mark A. Lemley. *Boston University Law Review*, Vol. 82 (2002).
- “Who’s Patenting What? An Empirical Exploration of Patent Prosecution,” by John R. Allison and Mark A. Lemley. *Vanderbilt Law Review*, Vol. 53 (2000).



Anne Hiaring Hocking

Partner
Hiaring+ Smith, LLP

Anne Hiaring Hocking has specialized in trademark and copyright law since 1981. She is Adjunct Professor Trademark, Copyright, and International Intellectual Property Law at Golden Gate University in San Francisco, California and Bangkok, Thailand. She has chaired numerous programs on Intellectual Property law topics, and has served as President of the San Francisco Intellectual Property Law

Association and speaker and moderator at numerous International Trademark Law Association programs. She has written for AmJur on copyright and trademark law topics, as well as presented numerous papers. She received her B.A. in German Literature from Reed College in 1973 and her J.D. from the University of California, Hastings College of the Law in 1979. In 2006 she received an LLM in International Law from Golden Gate University. She studied at the Albrecht-Ludwigs Universitaet in Freiburg and the Freie Universitaet in Berlin, Germany. She also worked for the Iran Center for Management Studies in Teheran, Iran before attending law school.

After working at two large law firms, she was the IP rights attorney for Pacific Telesis for five years, where she was responsible for all aspects of domestic and international trademark filing and enforcement, and all copyright and trade secret procedures. She founded her own firm in 1990 and Hiaring+Smith LLP in 2010.

9th Annual Conference on Recent Developments in Intellectual Property Law and Policy

Golden Gate University School of Law
San Francisco
November 5, 2010

Anne Hiaring Hocking
Hiaring + Smith, LLP
San Rafael, California

Five "Hot" Questions

- ⌘ Post-*Bose*, can anyone prove fraud in the TTAB?
- ⌘ How will increasing court acceptance of DJ actions affect trademark practice?
- ⌘ What, if anything, can we learn from recent confusion case wins and losses?
- ⌘ What, if anything, can we learn from recent dilution case wins and losses?
- ⌘ Has the blogger society beefed up the parody defense?

I. Proving Fraud in the USPTO Post-*Bose*

⌘ *Medinol v. Neuro Vasx*,
67 U.S.P.Q.2d 1205
(T.T.A.B. 2003)

⌘ "Knew or should have known standard" created virtually strict liability in application and registration

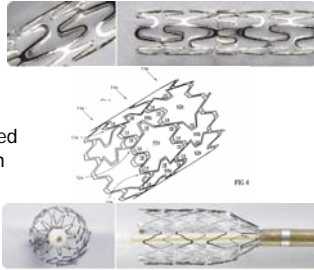

I. (cont.)

- ⌘ *In re Bose Corporation*, 580 F.3d 1204 (Fed. Cir. 2009)
 - ⊗ Overturned *Medinol*
 - ⊗ WAVE and ACOUSTIC WAVE marks registered, but Bose had ceased selling audio tape recorders and players 10 years earlier
 - ⊗ Board found fraud, cancelled Bose's registration of the marks
 - ⊗ Bose appealed cancellation



I. (cont.)



- ⌘ Court of Appeals reaffirmed high standard for proving fraud
- ⌘ Stated that the Board in *Medinol* "erroneously lowered the fraud standard to simple negligence standard" "by equating 'should have known' of the falsity with a subjective intent"

II. Pleading Fraud in a Cancellation Case

- ⌘ No longer sufficient to plead that registrant/applicant "knew or should have known" mark not in use
- ⌘ Must demonstrate registrant/applicant "knowingly ma[d]e[] false, material representations" "**with the intent to deceive**"

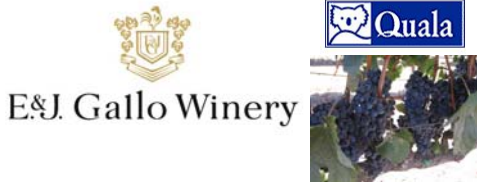

E&J Gallo Winery

E. & J. Gallo Winery v. Quala S.A., Opposition
No. 91186763 (T.T.A.B. December 7, 2009)

Petitioner must provide specific details: who, what, when, how of the supposed fraud



Asian and Western Classics B.V. v. Selkow, 92
U.S.P.Q.2d 1478 (T.T.A.B. 2009)

Must demonstrate fraud "either by its own specific factual knowledge or by specific facts showing that it is likely to establish such a claim"

⌘ *Daimlerchrysler Corp. v. American Motors Corp.*, 94
U.S.P.Q.2d 1086
(T.T.A.B. 2010)

⌘ Fraud claim found
legally sufficient,
supported by specific
statements, evidence



Post-*Bose* Open Questions

1. ⌘ When exactly does a party's "mistake" or "inadvertence" become so reckless as to constitute the intent to deceive element of fraud?
2. ⌘ What role will patent inequitable conduct case law play in shaping the future of trademark fraud cases?

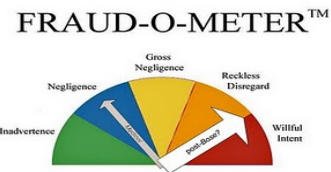

III. Likelihood of Confusion- Recent Lessons

⌘ The Designer Cases: HENSLEY and ABBOUD

Hensley Mfg. Inc. v. Propride, Inc.,
579 F. 3d 603, (6th Cir. 2009)

- ⌘ Would there be confusion between Jim Hensley's marks with Hensley Mfg. Inc., HENSLEY and HENSLEY ARROW, and his new trailer hitch designs with ProPride?
- ⌘ **NO, facts did not support a claim:** defendants no longer used HENSLEY or HENSLEY ARROW marks, and Jim Hensley used his full name, not the mark HENSLEY in marketing for ProPride



JA Apparel Corp. v. Abboud, 568 F. 3d. 390. (2d Cir. 2009) -- **Key Contract Language**

- ⌘ "The names, trademarks, trade names, service marks, logos, insignias, and designations identified on Schedule 1.1(a)(A), and all trademark registrations and applications therefor and the goodwill related thereto (collective the "Trademarks")"
- ⌘ "All rights to use and apply for the registration of the new trade names, trademarks, service marks, logos, insignias and designations containing the words "Joseph Abboud," "designed by Joseph Abboud," "by Joseph Abboud," "JOE," or "JA" ... (collectively, the "New Trademarks")"
- ⌘ "Intellectual Property was defined as 'all of the trademark registrations, service mark registrations and applications and copyright registrations and applications currently used by [Abboud....] in connection with the Trademarks....'"

JA Apparel Corp. v. Abboud, 568 F. 3d. 390. (2d Cir. 2009)



- ⌘ Court ruled that JA did not acquire "all of Abboud's rights to use his name for commercial purposes"
- ⌘ The difference between "name" and "trade name"
- ⌘ Contract referred only to use of ABBOUD as a mark

JA Apparel Corp. v. Abboud, 682 F. Supp. 2d 294 (S.D. N.Y. 2010)



- ⌘ Injunction preventing Abboud from using his name as a mark
- ⌘ Allowed "fair use": Abboud's name must be used descriptively, trademark "jaz" must be displayed in ad, must include disclaimer of affiliation with JA Apparel

III. Likelihood of Confusion: Practice Note

- ⌘ Rights to use the name must be descriptive
 - ☑ *Specific reference* of waiving the seller's right to the commercial use of the personal name prevents ambiguity
 - ☑ Under *Section 1115(b)(4)*

III. Likelihood of Confusion and Dilution—Cases of Interest



Hewlett Packard Development Co. v. Vudu Inc., 92 USPQ 2d 1630

Hewlett Packard opposes registration of the VUDU mark in Class 9 and four other classes
Phonetic equivalents with the same connotation → goods=computer software=likelihood for confusion



III. Likelihood of Confusion: Practice Note

- ⌘ Be careful with your description of goods and services: tailor it to avoid possible oppositions later
- ⌘ The Board can and will look to the literal description of goods in your application
- ⌘ Separate applications in separate classes

Heads up for "Generic" Marks

- ⌘ *In re* **HOTELS.COM**, 573 F. 3d 1300
- ⌘ CAFC upheld refusal to register the mark
 - "hotels" generic
 - ".com" added nothing
 - no secondary meaning shown



Advertise.com Inc. v. AOL Advertising, Inc. FKA August 3, 2010 F 3d. (9th Cir.)



- ⌘ 9th Circuit reversed entry of preliminary injunction entered by District Court
- ⌘ AOL'S ADVERTISING.COM registration not likely to support finding of likelihood of confusion with ADVERTISE.COM because of probably generic nature of mark
- ⌘ Genus="online advertising" or "internet advertising"
- ⌘ Relevant question: What are you?
 - Answer: "an advertising dot com"

III. Practice Note

- ⌘ Procedure oftentimes plays large role in TTAB proceedings, despite certain realities of the commercial marketplace
- ⌘ Alternative: appeal the refusal to a District Court

IV. Clarification on Likelihood of Dilution

⌘ CHARBUCKS

- Starbucks sued Black Bear Micro Roastery for its CHARBUCKS BLEND and MISTER CHARBUCKS blends
- District court dismissed the claim, finding no actual dilution
- Starbucks appealed...

Starbucks Corp. v. Wolfe's Borough Coffee, Inc. 588 F. 3d 97 (2d Cir. 2009)



- ⌘ Not necessary to prove likelihood of confusion to address dilution claims
- ⌘ Starbucks' claims of tarnishment and blurring both dismissed

V. Declaratory Judgment Actions after MedImmune

The Declaratory Judgment Statute

⌘ The Declaratory Judgment Act, 28 U.S.C. § 2201 (a), requires an “actual controversy” between parties to the declaratory judgment action

MedImmune, Inc. v. Genentech, Inc., 549 U.S. 118, 127 (2007)



MedImmune, Inc.



⌘ Addressed whether a patent licensee must be in breach of license agreement to bring a declaratory judgment action

⌘ Supreme Court: no
☑ Article III



Vantage Trailers, Inc. v. Beall Corp., 567 F. 3d 745 (5th Cir. 2009)
-No jurisdiction where the trailer at issue was not yet finalized
-Disputed that Vantage had begun to manufacture a trailer
-Was design sufficiently fixed to allow evaluation of a trademark infringement?

Monster Cable Products, Inc. v. Euroflex Srl, 642 F. Supp 2d 1001 (ND Cal. 2009)

⌘ One of the plaintiff's requests for declaratory relief regarding EFL's three pending applications for trademark registrations dismissed

⌘ Plaintiff has alleged no facts that this is a “real and substantial” dispute

⌘ EFL marks: “MONSTER,” “EUROFLEX,” “ITALY”

⌘ MCP does not anticipate suit from EFL

⌘ These factors support court's finding: “under the circumstances,” there is no substantial controversy

MONSTER



Surefoot LC v. Sure Foot Corp., 531 F. 3d 1236 (10th Cir. 2008)



-Will the concurrent use of the marks cause confusion?

-Sure Foot ND asserts that Surefoot UT's use of “Surefoot” mark causes confusion, therefore infringes on Sure Foot ND's trademark rights

-The “use of SURE-FOOT infringes on Sure Foot's rights... and creates a likelihood of confusion” and “there were several instances of actual confusion” at a trade show (Sept. 2, 1998 letter)

Express Scripts, Inc. v. Intel Corp., ___ F. Supp. ___ (E.D. Mo. 2010)

Intel sent notification letter to filer of an "intent to use" application for the mark INTELLACT. Defendant is in the pharmacy benefit management business
Application for "consulting services regarding healthcare costs . . . pharmaceutical benefit management services . . . Counseling in the nature of drug therapy . . ."
Intel's letter did not know of actual use; ESI entitled to declaratory judgment
Practice Point: Even the most innocuous cease and desist, even before use is known, based on an ITU application, could trigger jurisdiction.



VI. The Parody Defense

What is a Trademark Parody?

⌘ Fourth Circuit:

- ☑ For trademark purposes, "[a] 'parody' is defined as a simple form of entertainment conveyed by juxtaposing the irreverent representation of the trademark with the idealized image created by the mark's owner
- ☑ *People for the Ethical Treatment of Animals v. Doughney ("PETA")*, 263 F.3d 359, 366 (4th Cir. 2001)

Louis Vuitton Malletier v. Haute Diggity Dog, 507 F. 3d 252, 260 (4th Cir. 2007)

- ⌘ Where the famous mark is particularly strong, more likely that a parody will not impair the mark's distinctiveness
- ⌘ Defendant's Chewy Vuitton marks are a successful parody and do not blur the distinctiveness of plaintiff's marks
- ⌘ *Louis Vuitton Malletier v. Haute Diggity Dog*, 507 F. 3d 252, 260 (4th Cir. 2007)



Parody Extension in the Dilution Statute

- ⌘ Federal dilution statute excludes any "fair use, including a nominative or descriptive fair use, or facilitation of such fair use, of a famous mark by another person **other than as a designation of source for the person's own goods or services**, including use in connection with—
 - ☑ Advertising or promotion that permits consumers to compare goods or services; or
 - ☑ **Identifying and parodying, criticizing, or commenting upon the famous mark owner or the goods or services of the famous mark owner**
- ☑ 15 U.S.C. §1125 (c) (3).

A Case Finding No Infringement and/or Dilution

Protectmarriage.com – Yes on 8 v. Courage Campaign, 680 F. Supp. 2d 1225 (E.D. CA 2010)

- ⌘ Organizations for and against gay marriage
- ⌘ Defendant parodied plaintiff's logo depicting both "parents" wearing dresses, suggesting same-sex parents
 - ⌘ Used logo on website tracking a trial related to Prop 8
- ⌘ Defendant's use protected under First Amendment
 - ☑ Use relevant to expressive parody
 - ☑ Not explicitly misleading



PI Issued - Likely Infringement and/or Dilution



Why different from Chewy Vuitton?
Survey, plaintiff sells pet-related items
Anheuser-Busch, Inc. v. Vip Products, LLC, 666 F. Supp. 2d 974 (ED Missouri 2008)

Parody Cases Tried in the Blogger Court



VII. Really Hot Topics Worthy of An Entire Program

⌘ TIFFANY/EBAY and RESCUECOM CORP/GOOGLE

- ☑ Extent to which primary or secondary liability will arise for trademark infringement for on-line sellers and to online-advertisers

Tiffany v. eBay Inc., 600 F. 3d 93 (2d Cir. 2010)

- ⌘ eBay not liable as direct or contributory infringer when third parties sell infringing merchandise
- ⌘ eBay's general knowledge of infringing sales did not impose duty to remedy problem
- ⌘ Actual knowledge standard or no duty to take down: burden shifting to trademark owner



Rescuecom Corp. v. Google 562 F. 3d 123 (2d Cir. 2009)



- ⌘ Challenges search engines' practice of selling proprietary trademarks as 'keywords'
- ⌘ Looks like the practice is sanctioned. Similar results in the EU

Google Cases in the ECJ

- ⌘ Platform liability: Does the site infringe for if customers sell counterfeit or infringing product? Mixed results in the EU cases – on appeal to the ECJ
- ⌘ Search engine liability: Does Google infringe for selling Adwords, or is it a hosting service? Various results in European cases.
- ⌘ Yes, Google's AdWords system is a hosting service
 - ☑ Did find use in commerce, but nominative fair use and no likelihood of confusion



Anne Hiaring Hocking, Esq.
Hiaring + Smith, LLP
San Rafael, California 94903

Phone: 415 457-2040

Fax: 415 457-2822

Email: anne@hiaringsmith.com



Richard L. Kirkpatrick

Partner
Pillsbury Winthrop Shaw Pittman LLP

Mr. Kirkpatrick has focused on trademark and unfair competition law since 1980. His practice covers the full range of trademark protection and practice, including counseling; licensing; due diligence and other opinions on trademark aspects of initial public offerings, asset purchases, secured transactions, taxation and intellectual property holding companies; trademark enforcement and defense; litigations before the U.S. Trademark Trial and Appeal Board and courts; trademark clearance and registration worldwide; and trademark portfolio management. He is the leader of Pillsbury's International Trademark Team.

Mr. Kirkpatrick is the author of the leading treatise: "*Likelihood of Confusion in Trademark Law*," published by Practising Law Institute with semi-annual supplements, also available from Lexis and Kindle. He has also published numerous articles on trademark topics, detailed below. Mr. Kirkpatrick has been twice named by the *Daily Journal Intellectual Property Extra* as one of California's "Top IP Lawyers."

He is also a frequent lecturer at seminars, detailed below, of the Practising Law Institute (PLI), CEB, Intellectual Property Owners' Association (IPO), Thomson & Thomson (T&T), the International Trademark Association (INTA), Insight, San Francisco Intellectual Property Law Association (SFIPLA), Intellectual Property Law Sections of the California, Neva

Education

J.D., University of Maryland School of Law, 1980

B.A., Connecticut College, 1975 *summa cum laude*, Phi Beta Kappa

The Johns Hopkins University



Trademark Law Update: Preliminary Injunctions and Summary Judgments

Richard L. Kirkpatrick

*The 9th Annual Conference on Recent Developments in
Intellectual Property Law and Policy*

Golden Gate University School of Law

November 5, 2010

Pillsbury Winthrop Shaw Pittman LLP

Trademark Preliminary Injunction

Factors

- Likely success on the merits
- Likely irreparable injury
- Balance of harms favors movant
- Public interest (not being confused)

1 | Trademark Law Update:
Preliminary Injunctions and
Summary Judgments





Trademark Preliminary Injunction

General presumption:
likely success on the merits > irreparable harm

2 | Trademark Law Update:
Preliminary Injunctions and
Summary Judgments

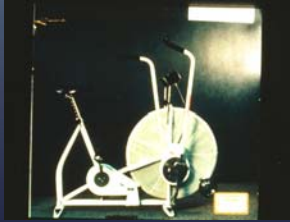

Trademark Preliminary Injunction

3 | Trademark Law Update:
Preliminary Injunctions and
Summary Judgments



Trademark Preliminary Injunction

Presumption Freight Train

- Copying > Presumed secondary meaning
- Copying > Presumed intent to infringe
- Intent to infringe > Presumed infringement
- Infringement > Presumed irreparable injury

=

Preliminary Injunction
see *Schwinn v Ross*, 870 F3d 1176 (7th Cir 1989)

4 | Trademark Law Update:
Preliminary Injunctions and
Summary Judgments



Trademark Preliminary Injunction

New Rule?

Recent Supreme Court cases indicate need for
independent proof of likely irreparable injury

5 | Trademark Law Update:
Preliminary Injunctions and
Summary Judgments



Supreme Court Cases

- eBay v MercExchange, 547 U.S. 388 (2006)(patent infringement; permanent injunction)
- Winter v Natural Res. Def. Council, 555 U.S. ____, 129 S.Ct. 365 (2008)(preliminary injunction; federal environmental law; reversing 9th Circuit)

8 | Trademark Law Update:
Preliminary Injunctions and
Summary Judgments



Lower Courts

- No presumption of irreparable injury; require proof of its likelihood
- N Am Med v Axiom, 522 F3d 303 (5th Cir 2008)(rule applicable to trademark cases)
- Maxim v Quintana, 654 FSupp2d 1024 (N.D. Cal 2009)(trademark infringement; citing *Winter*; plaintiffs "no longer entitled to a presumption of irreparable harm")
- CytoSport v Vital, 617 FSupp2d 1051 (E.D. Cal. 2009)(trademark infringement; citing *Winter*; "plaintiff must demonstrate that irreparable injury is likely") aff'd mem 348 Fed Appx 288 (9th Cir 2009)

7 | Trademark Law Update:
Preliminary Injunctions and
Summary Judgments



Trademark Summary Judgment

"This case is yet another example of the wisdom of the well-established principle that because of the intensely factual nature of trademark disputes, summary judgment is generally disfavored in the trademark arena."

- Fortune v Victoria's Secret, 618 F3d 1025, 1031 (9th Cir 2010)

8 | Trademark Law Update:
Preliminary Injunctions and
Summary Judgments



Trademark Summary Judgment Granted 2008 - 2010

- Venture v. McGills, 540 F.3d 56 (1st Cir. 2008)(confusion likely)
- George v. Imagination, 575 F.3d 383 (4th Cir. 2009)(confusion unlikely)
- Universal v. Collezione, 618 F3d 417 (4th Cir. 2010) (confusion likely)
- Bd. of Supervisors v. Smack, 550 F.3d 465 (5th Cir. 2008)(confusion likely)
- General Conference v. McGill, 617 F3d 402 (6th Cir. 2010) (confusion likely)
- Sensient v. Sensory Effects, 613 F.3d 754 (8th Cir. 2010) (confusion unlikely)
- Utah Lighthouse v Foundation, 527 F3d 1045 (10th Cir. 2008)(confusion unlikely)
- Tana v. Dantanna's, 611 F.3d 767 (11th Cir. 2010) (confusion unlikely)
- Odom's v. FF Acquisition, 600 F.3d 1343 (Fed. Cir. 2010) (confusion unlikely)

9 | Trademark Law Update:
Preliminary Injunctions and
Summary Judgments



Trademark Summary Judgment



both for food flavorings

- Confusion Likely Confusion Unlikely Motion Denied

613 F3d 754

10 | Trademark Law Update:
Preliminary Injunctions and
Summary Judgments



Trademark Summary Judgment



both for restaurants

- Confusion Likely Confusion Unlikely Motion Denied

611 F3d 767

11 | Trademark Law Update:
Preliminary Injunctions and
Summary Judgments



Trademark Summary Judgment



both for conducting religious observances

Confusion Likely
 Confusion Unlikely
 Motion Denied

617 F3d 402

12 | Trademark Law Update: Preliminary Injunctions and Summary Judgments



Trademark Summary Judgment

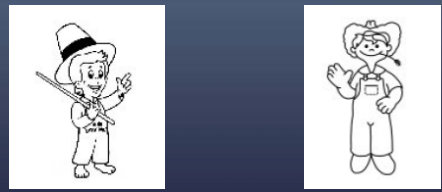

for foods for grocery store services

Confusion Likely
 Confusion Unlikely
 Motion Denied

600 F3d 1343

13 | Trademark Law Update: Preliminary Injunctions and Summary Judgments



Trademark Summary Judgment



both for car sales

Confusion Likely
 Confusion Unlikely
 Motion Denied

605 F3d 931

14 | Trademark Law Update: Preliminary Injunctions and Summary Judgments



Trademark Summary Judgment



Confusion Likely
 Confusion Unlikely
 Motion Denied

618 F3d 1025

15 | Trademark Law Update: Preliminary Injunctions and Summary Judgments



Trademark Summary Judgment



Confusion Likely
 Confusion Unlikely
 Motion Denied

576 F3d 221

16 | Trademark Law Update: Preliminary Injunctions and Summary Judgments



Trademark Summary Judgment



both for games

Confusion Likely
 Confusion Unlikely
 Motion Denied

575 F3d 383

17 | Trademark Law Update: Preliminary Injunctions and Summary Judgments



Trademark Summary Judgment



both for apparel

- Confusion Likely
- Confusion Unlikely
- Motion Denied

550 F3d 465

18 | Trademark Law Update:
Preliminary Injunctions and
Summary Judgments



Trademark Summary Judgment



both for religious services

- Confusion Likely
- Confusion Unlikely
- Motion Denied

527 F3d 1045

19 | Trademark Law Update:
Preliminary Injunctions and
Summary Judgments



Trademark Law Update: Preliminary Injunctions and Summary Judgments

Richard L. Kirkpatrick

*The 9th Annual Conference on Recent Developments in
Intellectual Property Law and Policy*

Golden Gate University School of Law

November 5, 2010

Pillsbury Winthrop Shaw Pittman LLP



GOLDEN GATE UNIVERSITY SCHOOL OF LAW

IP LAW CENTER (IPLC) ADVISORY BOARD

- | | |
|-------------------------|--|
| Peter Fowler | U.S. Patent and Trademark Office
Senior Counsel for Enforcement
U.S. Patent and Trademark Office
Peter.Fowler@USPTO.Gov |
| Barbara Friedman | Friedman Law Group
2600 55th Ave
Oakland, CA 94605
(510) 533-3308
barbara@thefriedmanlawgroup.com |
| Michael Glenn | Glenn Patent Group
3475 Edison Way, Suite L
Menlo Park, CA 94025
(650) 474-8400
Michael@glenn-law.com
http://www.glenn-law.com |
| M. Henry Heines | Townsend and Townsend and Crew, LLP
Two Embarcadero Center, 8th Floor
San Francisco, CA 94111
Telephone: (415) 576-0200
Fax: (415) 576-0300
mhheines@townsend.com |
| William B. Kezer | Townsend and Townsend and Crew, LLP
2175 North California Boulevard
Suite 600
Walnut Creek, CA 94596
Telephone: 925.472.5000
wbkezer@townsend.com |
| Jennifer Liu | Sony Computer Entertainment America, Inc.
919 E. Hillsdale Blvd.
Foster City, CA 94404
Jennifer_Liu@playstation.sony.com |

Jeffrey S. Mann

Morgan Lewis & Bockius LLP
One Market, Spear Street Tower
San Francisco, CA 94105-1126
jmann@morganlewis.com
Direct: 415.442.1119
Fax: 415.442.1001
Mobile: 415.860.0285
<http://www.morganlewis.com/>

Rob McFarlane

Carroll, Burdick & McDonough, LLP
44 Montgomery Street, Suite 400
San Francisco CA 94104
415.989.5900 (telephone)
415.989.0932 (fax)
rmcfarlane@cbmlaw.com

Joseph Anthony Meckes

Squire Sanders & Dempsey LLP
275 Battery St Ste 2600
San Francisco, CA 94111
(415) 954-0200 phone
(415) 391-2493 fax
jmeckes@ssd.com

Robert B. Morrill

Sidley Austin LLP
1801 Page Mill Road, Suite 110
Palo Alto, California 94304
650.565.7010
650.565.7100 Fax
rmorrill@sidley.com

Gregory N. Owen

Owen, Wickersham & Erickson P.C.
455 Market Street, Suite 1910
San Francisco, CA 94105
Gowen@owe.com
415-882-3200
<http://www.owe.com>

Brian Smith

Howrey, LLP
525 Market Street
Suite 3600
San Francisco, CA 94105-2708
SmithBrian@Howrey.com
Direct: 415.848.4936
<http://www.howrey.com>

Neil A. Smith

Ropers Majeski Kohn Bentley PC
201 Spear St Ste 1000
San Francisco, CA 94105
(408) 918-4523 phone
(408) 918-4501 fax
nsmith@rmkb.com

Michael Sutliffe

Haverstock & Owens LLP
162 N. Wolfe Road
Sunnyvale, CA 94086
(408) 530-9700
msutliffe@gmail.com

Hon. James Ware

<http://www.cand.uscourts.gov>
Courtroom Deputy - 408.535.5356

Kenneth Wilson

Carr & Ferrell, LLP
2200 Geng Rd.
Palo Alto, CA 94303
650.812.3404 direct
650.812.3444 fax
kwilson@carrferrell.com