



DePaul University
Via Sapiientiae

College of Science and Health Theses and
Dissertations

College of Science and Health

Fall 11-20-2012

Na⁺/K⁺-ATPase isoform regulation in three-spine stickleback (*Gasterosteus aculeatus*) during salinity acclimation

Shelby Judd

DePaul University, SJUDD224@YAHOO.COM

Follow this and additional works at: https://via.library.depaul.edu/csh_etd

 Part of the [Biology Commons](#)

Recommended Citation

Judd, Shelby, "Na⁺/K⁺-ATPase isoform regulation in three-spine stickleback (*Gasterosteus aculeatus*) during salinity acclimation" (2012). *College of Science and Health Theses and Dissertations*. 34.
https://via.library.depaul.edu/csh_etd/34

This Thesis is brought to you for free and open access by the College of Science and Health at Via Sapiientiae. It has been accepted for inclusion in College of Science and Health Theses and Dissertations by an authorized administrator of Via Sapiientiae. For more information, please contact digitalservices@depaul.edu.

**Na⁺/K⁺-ATPase isoform regulation in three-spine stickleback
(*Gasterosteus aculeatus*) during salinity acclimation**

A Thesis Presented in
Partial Fulfillment of the
Requirements for the Degree of
Master of Science

November 2012

By
Shelby M. Judd

Department of Biological Sciences
College of Science and Health
DePaul University
Chicago, Illinois

Table of Contents

Abstract.....	1
Chapter 1: General Introduction.....	2
Introduction.....	3
Osmoregulation and Ionoregulation.....	4
Physiology of Ionoregulation and Osmoregulation in Teleost Fishes.....	5
Freshwater Teleost Fishes.....	6
Marine Teleost Fishes.....	9
Euryhaline Fishes.....	10
Freshwater to Seawater Migration.....	11
Seawater to Freshwater Migration.....	14
Na ⁺ /K ⁺ -ATPase.....	16
Na ⁺ /K ⁺ -ATPase Subunits.....	17
Na ⁺ /K ⁺ -ATPase α Subunit Isoform Switching.....	18
Threes-spine Stickleback.....	20
Chapter 2: Na ⁺ /K ⁺ -ATPase isoform regulation in three-spine stickleback (<i>Gasterosteus aculeatus</i>) during salinity acclimation.....	25
Abstract.....	26
1. Introduction.....	26
2. Methods.....	30
2.1 Animals.....	30
2.2 Phylogenetic Analysis.....	31
2.3 Salinity Acclimation Experiment.....	32
2.4 Tissue Sampling.....	32
2.5 Plasma Analysis.....	33
2.6 Muscle Water Content.....	33
2.7 Measurement of gill Na ⁺ /K ⁺ -ATPase activity.....	33
2.8 Measurement of gill ion transporter mRNA expression.....	34
2.9 Statistical Analysis.....	36
3. Results.....	36
3.1 Phylogenetic Analysis of Na ⁺ /K ⁺ -ATPase α subunit isoforms.....	36
3.2 Seawater to Freshwater Transfer.....	36
3.2.1 Plasma Chloride and Percent Muscle Water.....	36
3.2.2 Gill Na ⁺ /K ⁺ -ATPase Activity.....	37
3.2.3 Gill Na ⁺ /K ⁺ -ATPase α -subunit isoform mRNA expression.....	37
3.3 Freshwater to Seawater Transfer.....	38
3.3.1 Plasma Chloride and Percent Muscle Water.....	38
3.3.2 Gill Na ⁺ /K ⁺ -ATPase Activity.....	38
3.3.3 Gill Na ⁺ /K ⁺ -ATPase α -subunit isoform mRNA expression.....	38
4. Discussion.....	39
5. Conclusions.....	44
Acknowledgments.....	44
Tables and Figures.....	45
Chapter 3: General Discussion.....	56
Literature Cited.....	60
Appendix 1: Na ⁺ /K ⁺ -ATPase α Subunit Isoform Transcript Sequence Alignments.....	69
Appendix 2: cDNA Similarity Matrix for Na ⁺ /K ⁺ -ATPase α Subunit Isoform Transcripts.....	86

Acknowledgements

This thesis could not have been completed without the help of many individuals. I am eternally in your debt. First and foremost, I would like to thank my thesis advisor, Jason Bystriansky, for his patience, guidance and support throughout this project. I not only learned a great deal about lab work but also what it takes to be a professional researcher. I am forever grateful for the opportunities he gave me to complete my experiment in Vancouver and to present a poster of my research at an international conference. I could not have wished for a better advisor.

Secondly, I would like to thank the faculty members of the Biology department at DePaul University who have contributed to the strengthening of my education and helped me to grow as a graduate student. Specifically, I would like to thank Windsor Aguirre and Margaret Silliker for serving on my thesis committee. Their input was essential for the completion of this project. Margaret has also been an invaluable source of guidance while completing this program as the director of graduate studies.

I am also grateful for all the help I received from researchers and students at the University of British Columbia. Patricia Schulte for all of her advice as well as for generously providing me with a place in her lab and space in an environmental chamber to conduct my experiment. I would also like to extend my gratitude to Callum Kingwell for collecting the fish, Mark Scott for his assistance with primer design and Mauricio Urbina Foneron for completing the final muscle sample weights.

My greatest appreciation goes out to Mattina Alonge. Your help was vital to the completion of this project and I could not have hoped for a better person to sit next to for hours in a freezing room removing bits from fish. I could not have done it without you and I look forward to our life-long friendship. I would also like to thank the other members of my posse, I am so glad to have met you all.

Furthermore, I would like to thank the undergraduate members of the Bystriansky lab. Specifically, I would like to recognize Casey Murphy and Penelope Antonopoulos for their assistance. Your help saved me hours of work and for that I am continually thankful.

Finally, I would like to thank all of my family, there are far too many to name, and my boyfriend, Kevin Tierney, for all of their love and support during my time at DePaul. You were always there for me. To listen to me talk about things that you didn't understand. To give me a hug when things were going well and when they weren't. I love you all. I would also like to express my deepest gratitude to my aunt and uncle, Maria and Ed Mudra. You took me into your home and have supported me in all of my endeavors ever since and for that I am forever grateful.

Mom and dad, I know you'd be proud.

Abstract

Most marine and all freshwater fishes regulate the ionic and osmotic composition of their extracellular fluids different from the outside environment. The gills play a prominent osmoregulatory role in maintaining whole body ion and water balance in fish living in both freshwater and saltwater environments. The ability of the gill to regulate salts is dependent on the action of the Na^+/K^+ -ATPase. When euryhaline fishes, fishes able to tolerate changes in external salinity, experience changes in environmental salinity, they alter their gill physiology and Na^+/K^+ -ATPase activity to handle changing osmotic and ionic stresses. The activity and relative expression of individual Na^+/K^+ -ATPase isoforms is known to change in some euryhaline species during acclimation to changing salinity, however the regulation of this important enzyme is poorly understood. The three-spine stickleback, *Gasterosteus aculeatus*, is a euryhaline fish species that inhabits a wide variety of environments ranging from freshwater to seawater with some freshwater populations being landlocked. The genome of *G. aculeatus* has been sequenced and contains four Na^+/K^+ -ATPase isoforms, of which three are expressed in the gills. This study examined the expression of these three Na^+/K^+ -ATPase isoforms in wild lake and marine populations of stickleback following transfer to either freshwater or seawater. Plasma chloride levels, muscle water content, gill Na^+/K^+ -ATPase activity and gill Na^+/K^+ -ATPase β subunit isoform mRNA expression levels were monitored. Marine and freshwater stickleback were able to regulate both plasma chloride levels and muscle water content, suggesting they can successfully acclimate to changing salinity; which is consistent with other studies. Marine fish transferred to freshwater showed a significant increase in gill Na^+/K^+ -ATPase activity while freshwater fish transferred to seawater did not. No significant change in mRNA expression was seen in either ATP1A3 isoforms following freshwater or seawater acclimation. However, a significant increase in the ATP1A1 isoform was observed when acclimating to seawater and a significant decrease was seen in the ATP1A1 isoform when acclimating to freshwater, suggesting ATP1A1 plays a role in ion secretion in marine habitats. These results confirm that three-spine stickleback independently regulate individual Na^+/K^+ -ATPase β subunit isoforms in their gills and that landlocked populations of the species have retained the ability to acclimate to seawater.

Chapter 1: General Introduction

Introduction

The gills of teleost fish play an important role in the regulation of osmotic and ionic balance in both freshwater and saltwater environments. Gill Na^+/K^+ -ATPase (a.k.a. the sodium pump) is a plasma membrane transporter, which is known to power whole body salt secretion in marine fishes and is involved in salt absorption in freshwater fishes. Despite decades of research on the role and regulation of gill Na^+/K^+ -ATPase in teleost fish ionoregulation, much still needs to be elucidated. The regulation of this vital protein is especially important in euryhaline species of fish that are capable of surviving in environments with fluctuating salinity.

The three-spine stickleback, *Gasterosteus aculeatus*, is a euryhaline, teleost fish that is widely distributed in the northern hemisphere (Bell and Foster, 1994). It can live in marine, brackish and freshwater habitats, with some populations showing an anadromous life-history, meaning they migrate from saltwater to freshwater to reproduce. Much research has been conducted on the behavior, morphology, ecology and evolution and speciation of *G. aculeatus* and it has become a model species in these fields (Bell and Foster, 1994; Östlund-Nilsson et al., 2007). Despite its popularity amongst biologists, much remains to be learned about the physiology of three-spine stickleback, especially when it comes to ionoregulation and water balance. Euryhaline fishes must alter their gill epithelium to handle changing osmotic and ionic stresses that they experience as they migrate between environments with differing salinity. Previous research on anadromous salmonid fishes (salmon, char and trout) has shown that the gills express multiple isoforms, which are proteins that have the same basic function but are slightly different, of the Na^+/K^+ -ATPase α subunit. Two of these isoforms are differentially expressed during acclimation to seawater (Richards et al., 2003; Bystriansky et al., 2006), suggesting they may have different functions in environments with different salinity. Despite this observation, the exact function of these Na^+/K^+ -ATPase isoforms has yet to be determined.

In order to further understand how different Na⁺/K⁺-ATPase α subunit isoforms function, my thesis will investigate what Na⁺/K⁺-ATPase α subunit isoforms are present in the three-spine stickleback, and how their expression may change with changing external salinity. I will take advantage of the fact that the genome of *G. aculeatus* has been fully sequenced (Kingsley and Peichel, 2007), allowing for the identification of which Na⁺/K⁺-ATPase α subunit isoforms may be expressed. To better explain the details of my study and the significance of my observations, our current understanding of the physiology of ion and water balance in fishes will be reviewed.

Osmoregulation and Ionoregulation

The salinity of an animal's environment exerts an ionic and osmotic stress on their cells. Ionic and osmotic stress occurs when there is a sudden change in the concentration of solutes in a solution around cells that results in the movement of water in or out of the cells through osmosis. To deal with this, some animals are termed osmo/ionoregulators as they maintain the osmotic and ionic composition of their extracellular fluids different from the outside world (Moyes and Schulte, 2008). In contrast, osmo/ionoconformers allow their internal environment (extracellular fluid) to be very similar to that of their external environment. Depending on the environment in which they live, animals face different ionic and water balance challenges. The salinity and ionic composition of the marine environment is very stable, allowing all marine invertebrates to be osmo/ionoconformers (Moyes and Schulte, 2008). In contrast, most marine fishes (with the exception of the chondrichthyes, the coelocanth and the hagfish) are osmoregulators. Marine osmoregulators maintain their tissues and extracellular fluids at approximately one-third the osmolality of seawater, making them prone to lose water and gain salts. In contrast, freshwater environments are very dilute as they have a very low salt content. For this reason, all freshwater animals deal with the constant loss of salts and gain of water, and must be osmo/ionoregulators (Moyes and Schulte, 2008). Finally, terrestrial animals live in a relatively dry

environment, and are constantly battling the loss of water due to dehydration. Since they are not immersed in water, they can only gain salts and water through active uptake from their diet, making them osmo/ionoregulators. Overall, each environment presents a unique set of ionic and osmotic challenges to animals. Osmoregulating animals have evolved specialized mechanisms to maintain salt and water homeostasis within their bodies depending on the environment in which they are found (Moyes and Schulte, 2008). Of particular interest, are the teleost fishes. This large group of bony fishes inhabits nearly every aquatic environment on the planet. Many species tolerate the harsh freshwater environment, with many more residing in seawater. A smaller number of teleosts are especially interesting, as they can survive in environments with varying salinity and some can even tolerate both fresh and saltwater environments. To do so, teleost fishes have evolved an impressive array of mechanisms to regulate their internal salts and water.

Physiology of Ionoregulation and Osmoregulation in Teleost Fishes

Teleost fishes inhabit a wide array of environments that vary in their salinity. Freshwater has very low ion concentrations giving it a salinity of $\sim 0.1\%$ (Dobson and Frid, 2009). The major ions in freshwater are bicarbonate ($\sim 1.7 \text{ mmol l}^{-1}$), calcium ($\sim 0.8 \text{ mmol l}^{-1}$), sodium and chloride ($\sim 0.5 \text{ mmol l}^{-1}$ each). Seawater on the other hand has an average salinity of $\sim 35\%$, of which more than 90% of the dissolved ions are made up of chloride ($\sim 548 \text{ mmol l}^{-1}$) and sodium ($\sim 470 \text{ mmol l}^{-1}$). In most regions, the ionic composition of seawater is conserved, while freshwater is slightly more variable, especially in regard to hardness and pH. Most fish species inhabit either freshwater or seawater environments, while some species are found in brackish water or hypersaline lakes. Despite their very broad distribution, most fish species are stenohaline, living in either freshwater or seawater and are unable to tolerate any change in environmental salinity (Evans et al., 2005). In contrast, some fishes are considered euryhaline as they can tolerate aquatic environments that vary in salinity. To better appreciate the challenges

faced by fish moving between environments with different salinities, the mechanisms used to maintain and regulate ionic and osmotic balance by freshwater and marine teleost fishes will be explored in further detail individually.

Freshwater Teleost Fishes

The internal environment of freshwater teleosts is hyperosmotic to freshwater. Because of this difference, freshwater teleosts must prevent the net gain of water and the net loss of salts. To prevent the net gain of water they drink very little (Bath and Eddy, 1979) and produce a very dilute urine (Marshall, 2002; Perry et al., 2003). To prevent the net loss of salts they reabsorb the majority of the salts from their urine and replace any lost salts through their diet and by active uptake by the gills. The gills are primarily responsible for Na^+ , Ca^{2+} and Cl^- uptake from freshwater, making them the predominate osmoregulatory organ in fishes.

The uptake of Na^+ and Cl^- by the gills is achieved through the creation of favorable electrochemical gradients that are produced by the movement of ions in acid-base secretion. The most accepted model of Na^+ and Cl^- uptake by teleost gills was first described by (Avella and Bornancin, 1989) and is carried out predominantly by chloride cells. Pavement cells have since been suggested to also play a role in the accumulation of Cl^- (Marshall, 2002). In this 'current model' (Figure 1a) the uptake of Na^+ and Cl^- is linked to the excretion of H^+ and HCO_3^- and involves the action of both the H^+ -ATPase and Na^+/K^+ -ATPase (Avella and Bornancin, 1989). A V-type H^+ -ATPase on the apical surface of the cell, facing the external environment, pumps H^+ out of the cell creating an electrical gradient. This gradient draws Na^+ into the cell passively from the water through a proposed epithelial Na^+ channel (ENaC). Na^+ is then pumped out of the gill cell into the blood by a Na^+/K^+ -ATPase on the basolateral membrane of the cell, facing the blood plasma. Na^+/K^+ -ATPase activity therefore maintains a very low intracellular Na^+ concentration that is thought to help apical Na^+ uptake from the water into the cell. The uptake of Cl^- is

linked to the secretion of HCO_3^- through an electroneutral $\text{Cl}^-/\text{HCO}_3^-$ exchanger located on the apical surface of the cell. The Cl^- then enters the blood through a yet to be described Cl^- channel/transporter in the basolateral membrane. This model for sodium uptake is in contrast to the 'classic model', initially proposed by Krogh (1938) and further refined by Kerseetter et al. (1970), in which Na^+ uptake involves an electroneutral Na^+/H^+ exchanger (NHE) on the apical membrane, powered by the Na^+/K^+ -ATPase. The NHE transports Na^+ into the cell in exchange for H^+ being transported out of the cell (Perry and Gilmour, 2006) instead of a separate H^+ -ATPase and epithelial Na^+ channel (Figure 1b). Like the mechanism above, the Na^+ is then pumped out of the gill cell into the blood by a Na^+/K^+ -ATPase on the basolateral membrane of the cell. The ability of this model to function in freshwater with very low Na^+ concentrations has been debated on thermodynamic constraints (Parks et al., 2008). It appears as though some fish species utilize the apical H^+ -ATPase and basolateral Na^+/K^+ -ATPase to drive Na^+ uptake via ENaC (current model) while others simply rely on the power of the Na^+/K^+ -ATPase to bring in sodium via the NHE (classic model). Interestingly, the expression of a functional ENaC in the apical membrane of gill chloride cells has yet to be observed (Evans, 2008; Hwang et al., 2011). Clearly, much more research is required to understand the mechanisms of active ion uptake by freshwater fish. Although never investigated in three-spine stickleback, it would appear they utilize the 'classic model' for sodium uptake as there is no obvious ENaC in the genome, while several forms of the NHE are present.

Due to the heterogeneous mixture of cells in the gills of freshwater fish, it has been difficult to identify the exact cells in which these processes take place. At one point, mitochondria-rich chloride cells were generally accepted as the cellular site of Na^+ and Cl^- uptake and pavement cells (PVC) only involved in the uptake of Cl^- (Evans et al., 1999; Marshall, 2002). However, recent studies on rainbow trout gills have identified two types of mitochondria-rich chloride cells based on their ability to bind peanut lectin agglutinin (PNA). These cells are believed to be the cellular sites of Na^+ and Cl^- uptake as well as acid-base secretion (Goss et al., 2001; Galvez et al., 2002; Perry et al., 2003). PNA⁻ cells are

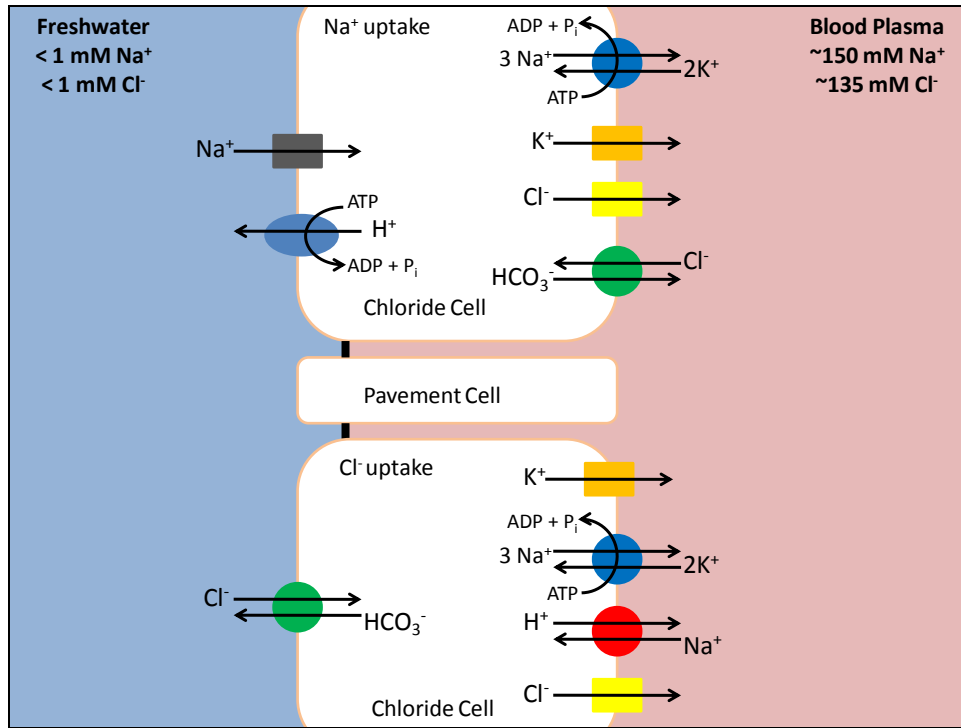

a. Current model adapted from Goss et al. (2001)

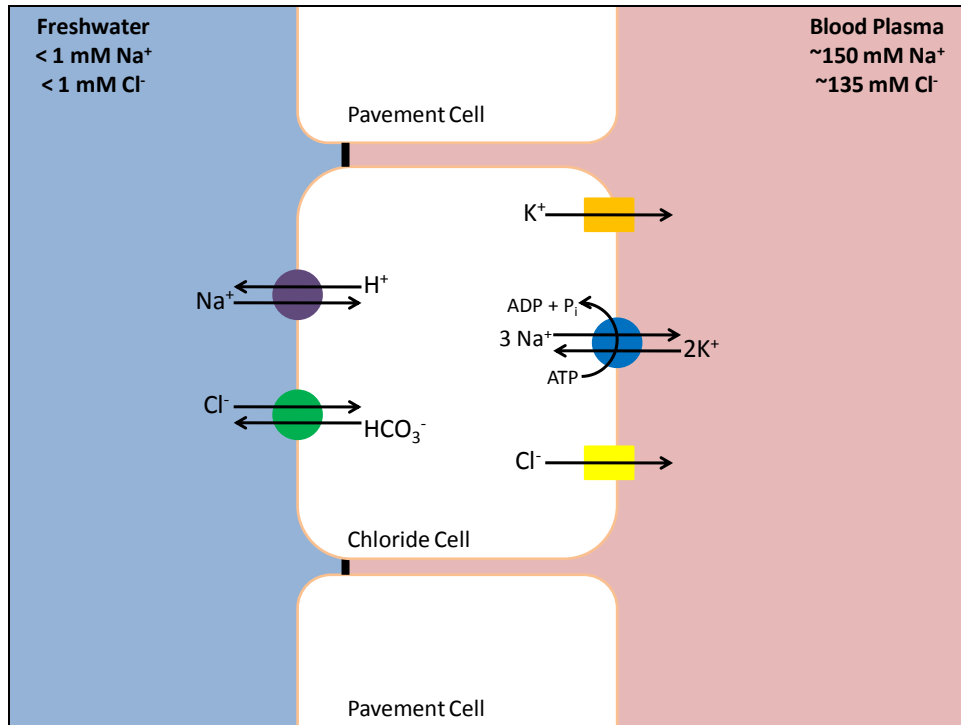

b. Classic model originally proposed by Krogh (1938) and adapted based on Kerseetter et al. (1970)

Figure 1: Ion transport models in freshwater

believed to be primarily involved in Na^+ uptake and acid secretion, while PNA^+ are involved in Cl^- uptake and base secretion. Different types of chloride cells have also been identified in other species including the Atlantic salmon, *Salmo salar*, (Pisam et al., 1988) and guppy, *Lebistes reticulatus*, (Pisam et al., 1987; Pisam et al., 1988).

Marine Teleost Fishes

Marine teleosts maintain their internal body composition hypoosmotic to seawater. In order to maintain their internal environment hypoosmotic to the marine environment, they must limit water loss. To combat this loss of water, marine teleosts drink saltwater (Smith, 1930). Most of the water ingested is absorbed passively along the digestive tract due to the active uptake of Na^+ , Cl^- and most other univalent ions. Marine teleosts also produce more concentrated urine than freshwater fish to conserve water. The excessive amounts of Na^+ and Cl^- absorbed from the ingested seawater are then actively secreted from the blood by the gills.

The model of secretion of excess blood Na^+ and Cl^- in the gills of marine fish involves the activity of two transporters and a selective Cl^- channel (Silva et al., 1977) (Figure 2). Na^+/K^+ -ATPase on the basolateral membrane of chloride cells drives Na^+ out of the cell into the blood in exchange for K^+ . This creates a large inward Na^+ gradient and large outward gradient for K^+ across the plasma membrane. These gradients power the coupled movement of Na^+ and Cl^- into the cell through a basolateral $\text{Na}^+/\text{K}^+/\text{Cl}^-$ cotransporter (NKCC). This cotransporter links the passive movement of one Na^+ ion into the cell down its concentration gradient to the uphill movement of one K^+ ion and two Cl^- ions into the cell. The net result is an increase in intracellular Cl^- levels. Cl^- levels increase to the point where they can then exit the cell passively down their electrochemical gradient through an apical Cl^- channel that is homologous to the cystic fibrosis transmembrane regulator (CFTR). Na^+ passively follows the movement of Cl^- through a paracellular pathway via leaky junctions between neighboring mitochondria-rich chloride cells

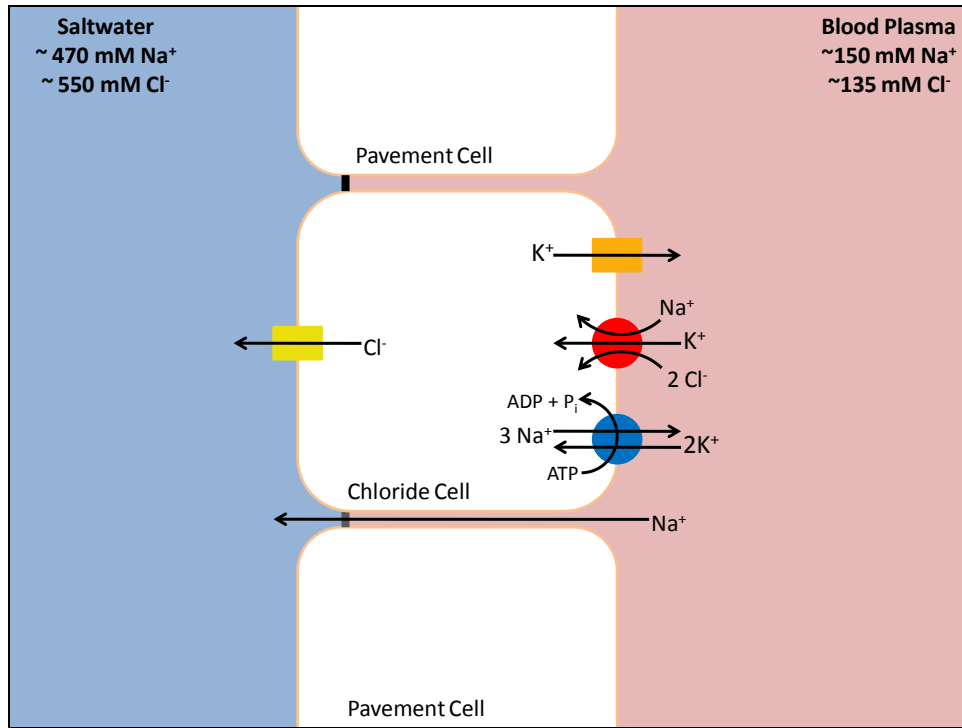

Figure 2: Ion transport model in seawater (adapted from Silva et al., 1977)

and accessory cells. Even though the concentration of both Cl^- and Na^+ in seawater is higher than in the cell or plasma (Wright, 1991), the ions are able to passively flow into the water due to electrical potential difference across the apical membrane in the case of Cl^- (cell negative) and the “leaky” junction in the case of Na^+ (plasma positive).

Euryhaline Fishes

Although most fish are stenohaline, able to live in only freshwater or marine environments, some fishes are termed euryhaline, and able to tolerate changes in external salinity (Evans et al., 2005). The degree of euryhalinity can differ greatly between species, with some able to tolerate large changes in salinity (e.g freshwater to full strength seawater), and others only capable of dealing with smaller fluctuations. Fish may encounter changes in salinity during migration to new environments (e.g. during migration from freshwater to seawater) or if their environment changes on them while they remain in

one place (e.g. during a tidal cycle). In order to deal with changing osmotic and ionic stresses, euryhaline fishes must reorganize their physiology when they encounter environments with different salinities. This involves a host of changes to the osmoregulatory tissues (e.g. gills, intestine and kidney) to allow for either active ion absorption or secretion, depending on salinity of the new environment. For example, the gills of fish migrating from freshwater to seawater would need to be modified to reduce the number and activity of ion transporters and channels important for active ion absorption in freshwater and increase those proteins known to be important for active ion secretion in seawater. A large amount of research has been conducted in this area to understand how certain species (especially salmonid fishes, tilapia and eels) acclimate to changing salinity.

Freshwater to Seawater Migration

Movement from freshwater to seawater requires a multitude of physiological changes to prevent loss of water and to switch from net ion uptake to net ion secretion. The process of acclimation to seawater involves a period of osmoregulatory adjustment that is divided into an initial crisis phase, during which faster physiological changes occur, followed by a stabilization phase, during which slower physiological changes occur, before reaching a new steady state (Gordon, 1959; Bath and Eddy, 1979). Upon entry to seawater, fish begin drinking immediately to offset the osmotic loss of water (Bath and Eddy, 1979). The ingested seawater stimulates the solute-linked transport of water through the active transport of Na^+ , K^+ and Cl^- into the blood stream. A decrease in kidney glomerular filtration rate and urine production also occurs and is accompanied by a change in the water permeability of the kidney tubule, which enhances reabsorption of water from the glomerular filtrate. The changes in the intestine and kidney lead to the procurement of water but result in a large salt load in blood plasma.

Teleosts normally maintain their plasma osmolality within a narrow range of 290 to 340 mosmol kg^{-1} regardless of the salinity they are in (McCormick and Saunders, 1987). Any prolonged

deviation from this range can result in problems. This makes plasma osmolality and ion levels useful indicators of osmoregulatory capacity. Studies on the acclimation of teleost fish to seawater have revealed a similar pattern in plasma ion and osmolality levels (Gordon, 1959; Parry, 1960b; Bath and Eddy, 1979; Madsen et al., 1996). During the initial critical phase, ion (Na^+ and Cl^-) and osmolality levels increase quickly because at this point fish are drinking seawater but have yet to modify their gills to actively secrete ions. During the stabilization phase, ion and osmolality levels decrease and level off at a new steady state due to the increased osmoregulatory capacity of the gills to secrete Na^+ and Cl^- and regulate their levels in blood plasma. This new steady state can either be at the same levels as when the fish was in freshwater or may stabilize at slightly higher levels. Muscle water content can also be used as an indicator of osmoregulatory capacity, which is especially useful with small fish due to the difficulty of obtaining a large enough quantity of plasma. Along with the initial increase in plasma ion and osmolality increases, a decrease in muscle water content is observed during the crisis phase in several teleosts (Parry, 1960b; Madsen and Naamansen, 1989; Madsen, 1990a; Madsen, 1990b; Madsen et al., 1996; Handeland et al., 1998; Sakamoto et al., 2001; Tipsmark et al., 2002). Much like plasma ion and osmolality levels, muscle water content returns to levels at or near freshwater levels during the stabilization phase. The total duration of this osmoregulatory adjustment period can differ between species and can range from hours to days to weeks. The inability to regulate these ions and plasma water can lead to dehydration, which is thought to be the main cause of mortality during seawater acclimation (Jobling, 1995). As discussed earlier the regulation of Na^+ and Cl^- is performed by the gill and appears to require an up-regulation of gill Na^+/K^+ -ATPase activity.

The gill chloride cells, main site of ion uptake and secretion, increase in size and abundance upon exposure to seawater (Eddy, 1982). The morphology of these cells as well as the gill epithelia also changes considerably during seawater exposure. Accessory cells in the gill epithelia adjacent to chloride cells send finger-like projections out to the apex of chloride cells (Laurent and Dunel, 1980) resulting in a

multicellular complex in which cells are connected by numerous and presumably “leaky” junctions (Sardet et al., 1979; Dunel-Erb and Laurent, 1980). The apical membrane of chloride cells is concave and recessed below the surface of surrounding cells forming an apical crypt (Evans et al., 1999). The basolateral membrane of chloride cells contains a tubular system made up of in-foldings of the plasma membrane. During exposure to seawater the in-folding of the tubular system increases thereby increasing the surface area of the basolateral membrane (Philpott, 1980). This presumably allows for the placement of a large number of ion transporters (e.g. Na^+/K^+ -ATPase). The expression of the apical CFTR (Singer et al., 2002; Scott et al., 2004a) and basolateral NKCC (Tipsmark et al., 2002; Scott et al., 2004a) and the expression and activity of the basolateral Na^+/K^+ -ATPase (discussed in detail below) usually increase following exposure to seawater.

An increase in gill Na^+/K^+ -ATPase activity is likely critical for successful seawater acclimation since the Na^+ and K^+ gradients that it creates and maintains are used to power the activity of CFTR and NKCC. Matais and Isaia (1972) confirmed the direct role of the Na^+/K^+ -ATPase in teleost ionoregulation. They observed a reduction in branchial Na^+ efflux from the European eel, *Anguilla anguilla*, within four minutes following the addition of ouabain, a specific Na^+/K^+ -ATPase inhibitor, to the external medium. Ouabain was also found to inhibit Cl^- efflux from the American eel, *Anguilla rostrata*, (Karnaky et al., 1976; Silva et al., 1977). Several studies have demonstrated branchial Na^+ and Cl^- efflux were dependent on external K^+ concentrations (Maetz, 1969; Motais and Isaia, 1972; Evans et al., 1973) providing further support for the importance of the activity of the gill Na^+/K^+ -ATPase. Gill Na^+/K^+ -ATPase activity is also positively correlated with rates of branchial Na^+ efflux (Epstein et al., 1980), while plasma Na^+ concentration is negatively correlated (Bornancin and DeRenzis, 1972). Additionally, the time course for increased branchial Na^+ efflux and rate of increase in gill Na^+/K^+ -ATPase activity has been found to be similar following seawater acclimation (Bornancin and DeRenzis, 1972; Forrest et al., 1973; Evans and

Mallery, 1975; Epstein et al., 1980). From the above observations, it is clear that there is a connection between the excretion of Na^+ and Cl^- from the plasma and gill Na^+/K^+ -ATPase activity.

Most studies have shown an increase in gill Na^+/K^+ -ATPase activity when euryhaline teleosts acclimated to freshwater are transferred to seawater (McCormick and Saunders, 1987). This is true for most species of anadromous salmonids (Folmar and Dickhoff, 1980), on which this migration has been most extensively studied. Many other euryhaline species also increase gill Na^+/K^+ -ATPase activity upon exposure to seawater. For example the killifish, *Fundulus heteroclitus*, (Scott et al., 2004a), flounder, *Plauchthys flesus* (Stagg and Shuttleworth, 1982) and *Paralichthys lethostigma* (Tipsmark et al., 2008), Japanese eel, *Anguilla japonica* (Utida et al., 1971), striped bass, *Morone saxatilis* (Tipsmark et al., 2004), and three-spine stickleback, *Gasterosteus aculeatus* (Schaarschmidt et al., 1999), all increase gill Na^+/K^+ -ATPase activity when transferred to seawater.

Seawater to Freshwater Migration

The movement from seawater to freshwater also requires a variety of physiological changes that work to prevent the gain of excess water and loss of ions to the environment; however, much less is known about these physiological processes compared to those involved in the migration from freshwater to seawater. As fish acclimated to seawater enter freshwater they reduce drinking rates to combat further water accumulation (Bath and Eddy, 1979). They also increase their kidney glomerular filtration rate (Jobling, 1995) allowing them to produce a very hypoosmotic urine to help combat the loss of further ions and to rid their bodies of any excess water. Some ions lost to the environment are replenished through the diet but the majority is actively absorbed by the gill.

Much like when acclimating to seawater, acclimation to freshwater also has an osmoregulatory adjustment period. During the initial exposure to freshwater, plasma ion (Na^+ and Cl^-) and osmolality levels decrease as ions are lost to the environment and the system is overwhelmed by excess water. As

osmoregulatory changes in the gill occur to better handle the uptake of ions, the plasma ion and osmolality levels return toward normal levels and reach a steady state. Initial exposure to freshwater results in an increase in muscle water content for several teleost species that returns to or near previous seawater levels as osmoregulatory process adjust (Parry, 1960b; Lotan, 1973; Jensen et al., 1998; Kelly et al., 1999; Tipsmark et al., 2008). As seen during seawater migrations, the inability to regulate plasma Na^+ and Cl^- levels can be detrimental to freshwater exposed fish.

As mentioned before, chloride cells are the location of active ion uptake in the gill. The morphology of chloride cells and surrounding epithelia also undergo changes during freshwater acclimation. In general the chloride cells in freshwater acclimated fish do not have as extensive of a tubular system as those acclimated to seawater (Pisam, 1981). The apical membrane in freshwater acclimated fish is generally flush with or protruding above the surrounding cells (Evans et al., 2005). However, in some species, such as tilapia, apical crypts are still present (Perry, 1997). Chloride cells also form extensive intercellular junctions with surrounding cells to form relatively impermeable barriers to ions (Sardet et al., 1979; Ernst et al., 1980). Following transfer to freshwater, accessory cells are rarely seen in the gill epithelia (Laurent and Dunel, 1980).

The expression of ion transporters in chloride cells of fish acclimated to freshwater has also been investigated. The expression of CFTR (Scott et al., 2004b; Tipsmark et al., 2004; Scott et al., 2005; Bystriansky and Schulte, 2011) and NKCC (Scott et al., 2004b; Scott et al., 2005; Tipsmark et al., 2008) has been observed to decrease during exposure to freshwater in some species while not being affected in others. There has been much debate about the mechanism of Na^+ uptake in the gill between the two models described above. In support of the classic model, different NHE transporters have been localized in gill epithelia (Ivanis et al., 2008) and an increase in the expression of NHE in the gills has also been observed (Scott et al., 2005). For the current model, increased expression (Tipsmark et al., 2004) and

activity (Bystriansky and Schulte, 2011) of the V-type H⁺-ATPase has been observed in some species while no change has been seen in others (Scott et al., 2004a) following exposure to freshwater. However, no homolog of ENaC or its equivalent has been found in teleost genomes (Evans, 2008; Hwang et al., 2011). Reviews on fish osmoregulation have described the importance of the gill Na⁺/K⁺-ATPase in the active uptake of ions in the current model as 'uncertain' (Perry, 1997) or 'unclear' (Evans et al., 2005). Despite its possibly ambiguous role, an increase in gill Na⁺/K⁺-ATPase activity following acclimation to freshwater has been observed in a variety of species including Arctic char, *Salvelinus alpinus* (Bystriansky et al., 2007b), Atlantic salmon, *Salmo salar* (Bystriansky and Schulte, 2011), flounder, *Platichthys flesus* (Stagg and Shuttleworth, 1982) and *Gillichthys mirabilis* (Doneen, 1981), killifish, *Fundulus heteroclitus* (Scott et al., 2004a; Scott et al., 2004b), milkfish, *Chanos chanos* (Lin et al., 2003), mullet, *Mugil cephalis* (Ciccotti et al., 1994) and *Chelon labrosus* (Gallis et al., 1979), pupfish, *Cyprinodon salinus* (Stuenkel and Hillyard, 1980), sea bass, *Dicentrarchus labrax* (Lasserre, 1971; Jensen et al., 1998), sea bream, *Mylio macrocephalus* (Kelly et al., 1999), sockeye salmon, *Oncorhynchus nerka* (Shrimpton et al., 2005) and striped bass, *Morone saxatilis* (Tipsmark et al., 2004). Due to its central role in both the ion uptake model of freshwater fish and the active ion secretion model of marine fishes, extra focus has been placed on the importance of gill Na⁺/K⁺-ATPase as a key regulator of ion and water balance in fish. Despite this attention, the regulation of the Na⁺/K⁺-ATPase is still poorly understood.

Na⁺/K⁺-ATPase

The Na⁺/K⁺-ATPase is a membrane bound, multi-subunit protein of the P-type ATPase family (Palmgren and Nissen, 2011). Members of the P-type ATPase family use the hydrolysis of ATP to move cations against their electrochemical gradients (Blanco and Mercer, 1998). The Na⁺/K⁺-ATPase cycles through different conformations and uses the hydrolysis of ATP to transport 3 Na⁺ out of the cell and 2 K⁺ into the cell. In doing so, the Na⁺/K⁺-ATPase maintains a low concentration of Na⁺ and a high

concentration of K^+ inside the cell. This creates steep concentration gradients that can be used by other membrane bound proteins to perform essential cellular functions. This function allows the Na^+/K^+ -ATPase to play an important role in the regulation of body fluid and salt balance (Blanco and Mercer, 1998). The subunits that are required for proper Na^+/K^+ -ATPase enzymatic activity are the catalytic α subunit and the regulatory β subunit (Blanco and Mercer, 1998; Mobasheri et al., 2000; Kaplan, 2002). The subunits combine to form a $\alpha\beta$ heterodimer in a 1:1 ratio. In addition, a third γ subunit is sometimes associated with the Na^+/K^+ -ATPase and appears to play a role in regulating overall pump kinetics (Blanco and Mercer, 1998).

Na^+/K^+ -ATPase Subunits

The α subunit of the Na^+/K^+ -ATPase is made up of approximately 1000 amino acids and has a molecular weight of approximately 110 kDa (Kaplan, 2002). It has binding sites for Na^+ , K^+ , ATP and the inhibitor ouabain as well as a phosphorylation site. It is responsible for the catalytic and transport activity of the pump. Both termini are located in the cytoplasm and it has 10 transmembrane domains with five exposed extracellular loops and three main intercellular structures. Four α subunit isoforms have been identified in mammals (Mobasheri et al., 2000). In mammals, the $\alpha1$ isoform is considered the housekeeping isoform due to its abundance and ubiquitous expression. The other isoforms have a more tissue specific expression with $\alpha2$ being primarily expressed in muscles, $\alpha3$ being primarily expressed mainly in the nervous system, and $\alpha4$ only being found in the testis (Mobasheri et al., 2000).

The β subunit is approximately 370 amino acids and is glycosylated, giving it a molecular weight between 40-60 kDa (Kaplan, 2002). The amino terminal is located in the cytoplasm and it passes through the membrane only once with the rest of the protein located in the extracellular space. The extracellular portion has three disulfide bridges that are required for proper function. It is thought to be involved in the proper targeting and insertion of the α subunit into the plasma membrane, and

influences Na^+ and K^+ affinity as well as catalytic activity (Bystriansky and Kaplan, 2007). Four β subunit isoforms have been identified in mammals (Kaplan, 2002). The $\beta 1$ isoform is ubiquitously expressed while the other three have a more tissue specific distribution. $\beta 2$, also named *adhesion molecule of glia* (AMOG) is involved in mediating interactions between neurons and glia (Mobasheri et al., 2000), $\beta 3$ is found in a variety of tissues including the brain, bone, kidney, lung, spleen, liver, intestines, and testis among others (Mobasheri et al., 2000; Blanco, 2005) and βm , or $\beta 4$, is found in muscle tissue (Blanco, 2005).

Different α and β isoforms combine with each other to form an α/β heterodimer. Different subunit isoforms may combine in different tissues and have been shown to exhibit different enzyme kinetics and affinities for cations and ATP (Blanco and Mercer, 1998). These slight differences in enzyme function may be very important in allowing the Na^+/K^+ -ATPase to work most effectively under specific physiological conditions, or in different cell types.

There is also a nonessential γ subunit that has been identified (Blanco and Mercer, 1998). It is between 8-14 kDa. Its amino terminus is located in the extracellular space and it only crosses the plasma membrane once. There is evidence that it can modify the function of the Na^+/K^+ -ATPase (Blanco and Mercer, 1998; Therien and Blostein, 2000) but its exact function is yet to be determined. The evolution of several isoforms of the Na^+/K^+ -ATPase and their tissue specific distribution suggests that each form of the enzyme has a specific cellular function or role to play. The role or function of each isoform is still unclear and requires further investigation to elucidate.

Na^+/K^+ -ATPase α Subunit Isoform Switching

After decades of studies outlining the importance of gill Na^+/K^+ -ATPase activity in the salinity acclimation of euryhaline fish species, an important breakthrough was made by Richards et al. (2003),

which unveiled a new level of complexity in understanding the regulation of the Na^+/K^+ -ATPase. In their study, five isoforms of the Na^+/K^+ -ATPase α subunit were sequenced in rainbow trout tissues. In general $\alpha 1a$ is found primarily in the gill, $\alpha 1b$ is found primarily in the brain, eye, gill and kidney, $\alpha 1c$ is ubiquitous, $\alpha 2$ is found in red and white muscle and $\alpha 3$ has a ubiquitous tissue distribution.

During seawater acclimation of rainbow trout two α isoforms of the gill Na^+/K^+ -ATPase were found to be differentially expressed (Richards et al., 2003; Bystriansky et al., 2006). The $\alpha 1b$ isoform was up regulated during seawater exposure while the $\alpha 1a$ was down regulated. This was later documented in both Atlantic salmon and Arctic char suggesting the original observation was exhibited by different salmonid species (Bystriansky et al. 2006). The opposite expression pattern was also later documented in salmonids during their natural spawning migration from seawater to freshwater (Shrimpton et al., 2005; Bystriansky et al., 2007b) and following exposure to freshwater under laboratory conditions (Bystriansky and Schulte, 2011). Together, these observations suggest that the expression of the $\alpha 1b$ isoform is important for the acclimation to seawater, while $\alpha 1a$ is important in the acclimation to freshwater. The importance of isoform switching was also supported by the observation that landlocked Arctic char that fail to acclimate to seawater do not up regulate gill $\alpha 1b$ isoform expression (Bystriansky et al., 2007a). Since the original set of experiments conducted on salmonid fishes, this reciprocal expression pattern of $\alpha 1$ isoforms has also been observed in tilapia, *Oreochromis mossambicus* (Tipsmark et al., 2011), suggesting that this phenomena may occur in a wide range of euryhaline species.

To further investigate this reciprocal salinity dependent Na^+/K^+ -ATPase isoform regulation, this study examined the salinity acclimation of the three-spine stickleback to both freshwater and seawater. The three-spine stickleback is a euryhaline species known to tolerate a wide range of habitats that differ

greatly in their environmental salinity and has had its genome sequenced making it the perfect model to further examine the regulation of the Na^+/K^+ -ATPase in differing salinities.

Three-spine Stickleback

Three-spine stickleback, *Gasterosteus aculeatus*, are a small (about 5cm from snout to the end of the vertebral column), teleost fish found in coastal seawater, brackish water and a wide array of freshwater habitats throughout boreal and temperate regions of the northern hemisphere (Bell and Foster, 1994). They occur around the margins of the Atlantic and Pacific oceans. On the Atlantic coast of North America they range from southern Greenland south to Chesapeake Bay. Freshwater populations occur throughout this range north of Maine. On the Pacific coast of North America they range from Alaska south to Baja California, Mexico. Populations can be of marine, anadromous, or resident freshwater forms. The marine form generally lives close to the coast but can be found in the open ocean. The freshwater forms can live in a wide variety of habitats including small floodplain pools, lakes of various sizes, rivers and streams.

Due to its adaptation to a variety of habitats, *G. aculeatus* is a phenotypically diverse superspecies (Bell, 2001) that is centered around the marine form that has, based on the fossil record, changed very little over the past 10 million years (Bell, 1994). The widely accepted model of diversification in the *G. aculeatus*-complex is based on the repeated and independent invasion of marine and anadromous ancestors into freshwater habitats following deglaciation (Münzing, 1963; Bell, 1995). The melting of glaciers at the end of the ice age resulted in the formation of new freshwater habitats throughout the Northern hemisphere that were colonized by marine and anadromous ancestors. Many of these newly formed freshwater populations became landlocked, separating them from other stickleback populations creating a variety of diverse stickleback populations. Over the past 10,000 to 15,000 years isolated freshwater populations of stickleback have been diverging from their marine

ancestors and exhibit differences in body size, number of dorsal spines, pattern and number of lateral plates, pelvic fin development and behavior (Östlund-Nilsson et al., 2007).

During their life cycle, three-spine stickleback may be exposed to a variety of environmental conditions including changing salinity. All population types complete a migration during the breeding season and build a benthic nest, a structure built on the bottom of a body of water in which eggs are incubated (Guderley, 1994). Freshwater populations migrate short distances and remain within their environment throughout the reproductive season and are therefore not exposed to changes in salinity. Marine and anadromous populations must migrate either back to the coast or into freshwater to reproduce. Depending on the exact environment chosen to reproduce in, these populations may move from the very stable marine environment to a coastal region such as an estuary with highly fluctuating salinities or a freshwater stream or lake. Anadromous populations experience the greatest changes in salinity during their breeding migration by far.

Research on salinity tolerance and osmoregulatory mechanisms of the three-spine stickleback has mostly focused on the lateral plate number rather than the life history of the fish being studied, with many studies not specifying the life-history of the fish used (Guderley, 1994). Three lateral plate morphs occur in the stickleback: complete, partial and low-plated morphs (Hagen and Gilbertson, 1972). Generally the completely plated morphs have an anadromous or marine life history while the low-plated morphs are found in freshwater, exceptions do exist. Due to the way that the freshwater stickleback has diverged from marine ancestors, populations may vary in their ability to handle different salinities. However, in general all lateral plate morphs are able to tolerate salinity fluctuations fairly well (Guderley, 1994).

The chloride cells of completely plated stickleback have an abundance of mitochondria, highly developed agranular endoplasmic reticulum and functional asymmetry in cell membranes, which are

features typical of ion-transporting cells (Matej, 1980 adapted from Guderley, 1994) and were present in fish adapted to both freshwater and seawater (Matej et al., 1981 adapted from Guderley, 1994).

Mitochondria were in greater abundance in the seawater fish. Upon examining the gills of completely plated stickleback transferred from seawater to freshwater, the gills displayed an increase in apical surface area (Biether, 1970 adapted from Guderley, 1994), a morphological change consistent with enhanced ion uptake.

The osmoregulatory response of laboratory-reared offspring of completely plated stickleback collected from the seashore was compared to offspring from low-plated stickleback collected from inland freshwater ditches (Gutz, 1970 adapted from Guderley, 1994). The offspring of the completely plated morph increased oxygen consumption during transfer from fresh to seawater, presumably due to the cost of tissue modifications and the active secretion of excess ions. The offspring of low-plated morph fish, when transferred from fresh to seawater, exhibited a volume regulatory response during which tissue free amino acid concentrations rose, presumably due to an increase in plasma osmolarity. No increase in oxygen consumption was seen. Regulating volume by changing the concentration of organic solutes, such as free amino acids and small carbohydrates, has the benefit of not perturbing macromolecular structure and function like changes in ion concentration could. Schaarschmidt et al. (1999) found taurine to be the most important organic osmolyte in the acclimation of a freshwater and two brackish water populations of stickleback acclimated to 10‰ before being transferred to either freshwater (0.3‰) at 4°C and 15°C or brackish water (20‰) at 4°C and 15°C. While cellular volume regulation is part of the teleost osmoregulatory repertoire (King and Goldstein, 1983), the response has been reduced through the action of the gills, kidney and intestine to maintain hypotonicity in seawater and hypertonicity in freshwater.

Migratory behavior and salinity tolerance of three-spine sticklebacks varies with the seasons and may be influenced by the breeding season. The breeding season begins in spring and ends in autumn with some variation in populations depending on latitude. Anadromous forms show a preference for freshwater in the spring and seawater in the winter (Lam and Hoar, 1967). The freshwater, low-plated morph can tolerate salinities as high as 45‰ outside of the breeding season but loses this tolerance when reproductively mature (Knoch and Heuts, 1942 adapted from Guderley, 1994). Since they breed in the summer, the environmental changes that come with changing seasons may also help to initiate the migratory behavior and therefore salinity tolerance. Two of these environmental changes may be the photoperiod and temperature. As the days get longer and the temperature increases in late winter early spring, anadromous forms seem to prefer lower salinity levels (Baggerman, 1957 adapted from Guderley, 1994). Anadromous, completely plated morphs collected in early spring that were acclimated to long day length also preferred low salinities (Audet, 1985). As the days begin to get shorter in autumn, they begin to prefer higher salinity levels. However, Baggerman (1957 adapted from Guderley, 1994) found that salinity preference shifted in anadromous forms at the end of the breeding season even though day lengths remained long. The termination of reproduction may shift salinity preference through changes in hormones associated with the reproduction cycle.

Salinity tolerance may vary with developmental stage (Gerking and Lee, 1980). Eggs and fry have a higher surface to volume ratio and may not have as highly developed osmoregulatory capacities as their adult counterparts. In a study by Campeau et al. (1984), anadromous males were allowed to care for their eggs until they hatched at a salinity of 20‰ and at different intervals post hatching the salinity tolerance of the fry were examined. Significantly higher mortalities were seen at 0 and 28‰ in week old fry than at the control salinity (21‰). Clearly the salinity the fry are raised in determined their salinity tolerance initially but by five weeks the fry were euryhaline. Juvenile anadromous three-spine stickleback remain on the breeding grounds longer than adults and don't seem to prefer higher salinity

levels until two months after hatching (Guderley, 1994). Their migration to seawater may be more influenced by photoperiod than adult anadromous stickleback, preferring to remain in freshwater during the long days of summer and then migrating to seawater, as the days grow shorter in autumn.

The genome of the three-spine stickleback was fully sequenced by the summer of 2005 and the first whole genome assembly was released to in February 2006 (Kingsley and Peichel, 2007). Having access to this full genome is a valuable tool we can use to identify which Na^+/K^+ -ATPase subunit isoforms are present in the genome, as well as for creating primers for determining mRNA levels of each individual Na^+/K^+ -ATPase isoform.

The focus of my thesis was to examine the regulation of gill Na^+/K^+ -ATPase in three-spine stickleback during salinity acclimation. At this point there is very little information available on how three-spine stickleback modify their osmoregulatory tissues to acclimate to changing salinity. The aim of this study was to further understand how salinity regulates the expression of Na^+/K^+ -ATPase α subunits by testing the hypothesis that two of the gill Na^+/K^+ -ATPase α subunits in three-spine stickleback would show reciprocal regulation when acclimating to different salinities.

Chapter 2: Na⁺/K⁺-ATPase isoform regulation in three-spine stickleback (*Gasterosteus aculeatus*) during salinity acclimation

Abstract

The three-spine stickleback, *Gasterosteus aculeatus*, is a euryhaline fish species that inhabits a wide variety of environments ranging from freshwater to seawater with some freshwater populations being landlocked. Gill Na⁺/K⁺-ATPase plays an important role in regulating whole body ion and water balance in fish. The relative expression of Individual Na⁺/K⁺-ATPase isoforms is known to change in some euryhaline species during acclimation to changing salinity. The genome of *G. aculeatus* has been sequenced and four Na⁺/K⁺-ATPase isoforms have been identified making them an ideal species to study the mechanisms of regulation of individual isoforms. This study examined the expression of three isoforms of Na⁺/K⁺-ATPase in the gill of wild *G. aculeatus* collected from either freshwater or seawater habitats. Fish were transferred to either seawater or freshwater respectively and gill Na⁺/K⁺-ATPase activity and expression were monitored. Both marine and freshwater stickleback were able to regulate plasma chloride levels and muscle water content, suggesting they can successfully acclimate to changing salinity. This is consistent with other studies. Marine fish transferred to freshwater showed a significant increase in gill Na⁺/K⁺-ATPase activity while freshwater fish transferred to seawater did not. No significant change in mRNA expression was seen in either ATP1A3 isoforms following freshwater or seawater acclimation. However, a significant decrease was seen in the ATP1A1 isoform when acclimating to freshwater and a significant increase in the ATP1A1 isoform when acclimating to seawater, suggesting *G. aculeatus* also displays isoform specific Na⁺/K⁺-ATPase regulation.

1. Introduction

Teleost fishes are either classified as stenohaline, only able to survive in a narrow range of salinities, or euryhaline, able to survive in a wide range of salinities. In order to acclimate to changing osmotic and ionic stresses, euryhaline fishes must reorganize the physiology of their osmoregulatory tissues, including the gills, kidney and intestine to maintain proper ion and water balance. The gills are primarily responsible for the active uptake of ions by freshwater fish and their secretion in marine fish

(reviewed in Evans et al., 2005). When a euryhaline fish encounters a change in salinity, the ion flux of their gills must change accordingly, to suit their new environment.

The gill Na^+/K^+ -ATPase plays an important role in regulating plasma Na^+ and Cl^- levels in both marine and freshwater fishes. It does this by creating and maintaining large Na^+ and K^+ gradients across the basolateral membrane of the gill, which are then used to actively move ions into or out of the fish depending on their environment. In seawater acclimated fish, gill Na^+/K^+ -ATPase is considered the exclusive driving force for the secretion of excess plasma Na^+ and Cl^- (Silva et al., 1977), making the regulation of its activity critical for successful osmoregulation. The role of Na^+/K^+ -ATPase in the uptake of Na^+ and Cl^- by freshwater fish is not as well understood (Evans et al., 2005), but does appear to be central to the workings of two proposed ion uptake models. The current model combines the activity of an apical V-type H^+ -ATPase to generate a favorable electrochemical gradient that drives Na^+ uptake through an apical Na^+ channel into the cell (Avella and Bornancin, 1989). The classic model, originally proposed by Krogh (1938), involves an electroneutral Na^+/H^+ exchanger on the apical membrane that transports Na^+ into the cell in exchange for H^+ (Kersetter et al., 1970; Perry and Gilmour, 2006). In both models the Na^+/K^+ -ATPase then moves the Na^+ across the basolateral membrane out of the cell and into the blood, thereby maintaining a low intracellular Na^+ concentration that improves the gradient for apical Na^+ uptake. The Na^+/K^+ -ATPase is therefore critical to ion balance in teleost fishes, regardless of the environment in which they live. The movement of euryhaline fish between salinities requires the gill to change between an ion secreting tissue and a tissue that actively uptakes ions.

The functional Na^+/K^+ -ATPase is made up of two essential protein subunits, a catalytic α subunit and a glycoprotein β subunit that combine in a 1:1 ratio to create an $\alpha\beta$ heterodimer (Mobasheri et al., 2000). Previous research on seawater acclimation of salmonid fishes (salmon, char and trout) has shown that two Na^+/K^+ -ATPase α subunit isoforms are differentially expressed in the gills (Richards et

al., 2003; Bystriansky et al., 2006). The $\alpha 1b$ isoform is up-regulated during seawater exposure while the $\alpha 1a$ is down regulated. The opposite expression pattern is seen in salmonids exposed to freshwater during their natural spawning migration (Shrimpton et al., 2005; Bystriansky et al., 2007b) and under laboratory conditions (Bystriansky and Schulte, 2011). These observations suggest that the $\alpha 1b$ isoform is important for successful acclimation to seawater, while $\alpha 1a$ is important for acclimation to freshwater. This is further supported by the observation that landlocked Arctic char that fail to acclimate to seawater do not up regulate gill $\alpha 1b$ expression (Bystriansky et al., 2007a). Recently this reciprocal expression pattern of $\alpha 1$ isoforms was also observed in tilapia, *Oreochromis mossambicus* (Tipsmark et al., 2011), suggesting that this phenomena can occur in other fishes as well. In order to better understand the role of different gill Na^+/K^+ -ATPase isoforms in ion regulation of freshwater, marine and euryhaline fish further studies are needed.

The euryhaline three-spine stickleback, *Gasterosteus aculeatus*, is a small, streamlined teleost found in coastal marine, brackish water and a wide array of freshwater habitats throughout boreal and temperate regions of the northern hemisphere (Bell and Foster, 1994). Many freshwater populations have become landlocked, separated from the ocean by natural barriers, making them an interesting species to study the evolution of salinity tolerance. The widely accepted model used to describe the diversification and distribution of the *G. aculeatus*-complex is based on the repeated and independent invasion of marine ancestors into freshwater habitats following deglaciation (Münzing, 1963; Bell, 1995). As different freshwater populations are descendants of marine ancestors that invaded freshwater at different times, landlocked populations may have different osmoregulatory capacities due to a loss of salinity tolerance (Guderley, 1994). Landlocked populations of other euryhaline fish species, including sockeye salmon (Foote et al., 1992), Atlantic salmon (Burton and Idler, 1984; Birt and Green, 1993) and Arctic char (Staurnes et al., 1992; Eliassen et al., 1998; Bystriansky et al., 2007b) have been shown to have a reduced or very limited capacity to tolerate seawater. The reason for this loss of seawater

tolerance is not understood and requires greater study. To understand the mechanisms that limit salinity tolerance, the three-spine stickleback makes an ideal model species to study as their evolution and bio-geographical distribution has been so well studied (Bell and Foster, 1994; Östlund-Nilsson et al., 2007). The genome of the three-spine stickleback has been fully sequenced (Kingsley and Peichel, 2007), providing a useful resource to further understand the physiology of osmoregulation in euryhaline fishes.

Past research on salinity tolerance and osmoregulation in the three-spine stickleback has focused on the lateral plate morph rather than on the life history of the fish, with many studies not specifying the life-history of the fish used (Guderley, 1994). Three lateral plate morphs occur in the stickleback: complete, partial and low-plated (Hagen and Gilbertson, 1972). Generally the completely plated morph was considered marine or anadromous while the low-plated morph was considered to be the freshwater form; however, exceptions do exist. An increase in oxygen consumption was seen in the transfer of complete and partial plated morphs from freshwater to seawater indicating the osmoregulatory changes required are energetically expensive (Gutz, 1970 adapted from Guderley, 1994). The low-plated morph, on the other hand, do not increase their oxygen consumption but use a cell volume regulatory mechanism in which they increase the concentration of free amino acids available, a response that may not be as effective. When stickleback caught from freshwater and brackish water populations, acclimated to 10‰, were transferred to 35‰ seawater an increase in Na^+/K^+ -ATPase activity was observed (Schaarschmidt et al., 1999). These populations also showed high levels of taurine, an organic osmolyte used in cell volume regulation, when acclimating to freshwater and 20‰ brackish water. Salinity tolerance varies seasonally and is controlled by hormones under the influence of day length and temperature associated with the breeding season and or developmental stage (Baggerman, 1957; Campeau et al., 1984; Guderley, 1994). Despite these findings, little research has been done on the gill physiology of ion regulation in the stickleback.

This study examined the role and regulation of gill Na^+/K^+ -ATPase in the acclimation of three-spine stickleback to changing salinity. Wild marine caught fish were acclimated to freshwater for 14 days, over which time the activity and mRNA expression patterns of individual Na^+/K^+ -ATPase α subunit isoforms were monitored. The same parameters were measured in gills of three-spine stickleback collected from a freshwater population following acclimation to full strength (32‰) seawater. We predicted that both populations would be able to acclimate to changing salinity and that Na^+/K^+ -ATPase activity would increase during acclimation to both increasing and decreasing salinity. We also predicted that two of the α subunit isoforms would show a reciprocal expression pattern as seen in other species, with the expression of one isoform increasing upon exposure to seawater and the other upon exposure to freshwater.

2. Methods

2.1 Animals

Three-spine stickleback (*Gasterosteus aculeatus*) were collected from both freshwater and marine habitats in the Sunshine coast region of British Columbia, Canada using unbaited minnow traps. Freshwater three-spine stickleback were collected from Lily Lake, British Columbia, Canada (49°36'45"N, 124°01'20"W) and marine three-spine sticklebacks were collected from Oyster Lagoon, Pender Harbor, British Columbia, Canada (49°32', 124°2'). This freshwater population has been isolated since approximately 11,000 BP when the existing lakes and streams in the area formed after isostatic rebound that occurred after lowlands in the area were covered by seawater as the glacier ice in the area receded (Foster, 1994). Fish were held in large bags supplemented with oxygen, placed in coolers with ice packs and transported back to the University of British Columbia. At the University of British Columbia, fish were held in 75-gallon aquaria, containing either dechlorinated freshwater or artificial seawater (32‰) (Instant Ocean, Madison, WI, USA) matching the salinity of the environment they were collected from. The aquaria were housed in an environmental chamber held at 15°C with a 12:12 photoperiod. Fish

were fed blood worms to satiation daily and held for at least one month under these conditions to allow for acclimation to the lab before the start of experiments. All experimental procedures fully comply with Canadian Council of Animal Care guidelines (protocol no. A07-0288).

2.2 Phylogenetic Analysis

A phylogenetic analysis was completed to see how each of the stickleback isoforms grouped with other known Na⁺/K⁺-ATPase α subunit isoforms as well as to confirm the annotations of the stickleback genome. To perform a phylogenetic analysis, three-spine stickleback Na⁺/K⁺-ATPase α subunit protein sequences were obtained from Ensembl: stickleback ATP1A1 (ENSGACG00000014324); stickleback ATP1A2 (ENSGACG00000017683); stickleback ATP1A3 (1 of 2) (ENSGACG00000009524); stickleback ATP1A3 (2 of 2) (ENSGACG00000001959). For α subunits with multiple transcripts in the genome, all transcripts were used. Protein sequences of other Na⁺/K⁺-ATPase α subunits were obtained from GenBank: chicken α 1 (J03230); chicken α 2 (P24797); chicken α 3 (P24798); eel (Q92030); human α 1 (NP000692); human α 2 (NP000693); human α 3 (NP689509); human α 4 (NP653300); killifish α 1 (AY05702); killifish α 2 (AY057073); mouse α 3 (NP659170); mouse α 4 (Q9WV27); rat α 1 (NP036636); rat α 2 (NM012505); rat α 3 (NP036638); rat α 4 (NP074039); tilapia α 1a (U82549); tilapia α 1b (TMU82549); tilapia α 3 (AF109409); torpedo ray (P05025); trout α 1a (AY31931); trout α 1b (AY319390); trout α 1c (AY319389); trout α 2 (AY319387); trout α 3 (AY319388); whitesucker (X58629); Xenopus α 1 (Q92123); Xenopus α 2 (NM001089643); Xenopus α 3 (NM001086971); zebrafish α 1 (AF286372); zebrafish α 2 (AF286373); zebrafish α 3 (AF286374); zebrafish α 4 (AF308598); zebrafish α 5 (AF308599); zebrafish α 6 (ZY008376); zebrafish α 7 (AY008375); zebrafish α 8 (AY008376); fruitfly (AAF5586). Nomenclature for stickleback α subunit isoforms was annotated in the genome. Nomenclature for α subunit isoforms of the other fish species used were based primarily on tissue distribution or perceived function in comparison with trout α subunit isoforms. Sequences were aligned using

ClustalW and phylogenetic analysis was performed using the neighbor-joining method using MEGA5 software. The support for each node was assessed using 500 bootstrap replicates.

2.3 Salinity Acclimation Experiment

This study consisted of two experiments, one which transferred stickleback of marine origin to either seawater (control) or freshwater (experimental), and one which transferred stickleback collected from a landlocked freshwater environment to either freshwater (control) or seawater (experimental). To start each experiment, fish were transferred directly from their holding tank to either a control aquarium (containing water of the same salinity as the holding tank, 0‰ or 32‰ saltwater) or to an experimental tank containing water of the alternate salinity (0‰ or 32‰ saltwater). A separate control and experimental group was used for sampling after 6 hours, 1, 2, 4, 7 and 14 days. Each experimental or control group consisted of eight fish. A total of 96 stickleback were used for each experiment (8 fish per group x 2 conditions (control vs. experimental) x 6 time points). Stickleback of marine origin had an average weight of 1.8 ± 0.04 grams, and 60.4 ± 0.42 mm fork length. Stickleback of freshwater origin had an average weight of 1.3 ± 0.03 grams, and 54.2 ± 0.43 mm fork length. Mean fish size was not statistically different between sampling groups within the same experiment ($p > 0.05$), however marine fish were significantly larger than freshwater collected individuals ($p < 0.001$). The temperature and salinity of all aquaria were monitored daily. Fish were fed bloodworms to satiation every second day, except on the day before, on, and after transfer as well as the day before or of sampling.

2.4 Tissue Sampling

Six hours, 1, 2, 4, 7 and 14 days following transfer fish were collected from their aquarium and transferred to an aesthetic bath containing MS-222 (100mg/L) buffered with sodium bicarbonate (100mg/L). After approximately two minutes, fish lost equilibrium and stopped responding to external stimuli. Fish were blotted dry and weight and fork length were measured. Following caudal severance blood samples were collected using a heparinized capillary tube and centrifuged for 5 minutes. Plasma

was extracted from the capillary tube and frozen in liquid N₂. Immediately after taking the blood sample, the spinal cord was severed and gill samples were taken and immediately frozen in liquid N₂. A white muscle sample was collected and placed into a pre-weighed aluminum weigh boat for determination of muscle water content.

2.5 Plasma Analysis

Plasma chloride levels were measured using a HBI Digital Chloridometer (Haake Buchler Instruments Inc., Sadlebrook, NJ, USA). For some individuals, the volume of plasma collected was not adequate to perform chloride analysis, therefore sample sizes ranged from 3 to 8 for the seawater to freshwater experiment, and from 4 to 8 for the freshwater to seawater experiment.

2.6 Muscle Water Content

White muscle samples were placed in pre-weighed aluminum weigh boats and re-weighed to determine muscle wet weight. Samples were then placed in a 60°C drying oven to dehydrate and re-weighed every second day until the weights stabilized. This weight was considered the dry weight and was compared to wet weight to calculate the original percent muscle water content.

2.7 Measurement of gill Na⁺/K⁺-ATPase activity

Gill filaments were homogenized on ice in SEID (pH = 7.5, 150 mmolL⁻¹ sucrose, 10 mmolL⁻¹ EDTA, 50 mmolL⁻¹ imidazole, 0.1% sodium deoxycholate) buffer using a ground-glass homogenizer. Homogenates were centrifuged for 1 min (4°C) at 3,000g to remove gill filaments and other insoluble material. The supernatant was used directly in the assay of gill Na⁺/K⁺-ATPase activity, which was determined at 15°C. Na⁺/K⁺-ATPase activity was measured by a method modified from Hu and Kaplan (2000) by monitoring the difference in the amount of inorganic phosphate (P_i) liberated from gill homogenates in the presence and absence of the Na⁺/K⁺-ATPase-specific inhibitor ouabain. A final concentration of 1mmolL⁻¹ ouabain was used and was previously determined to fully inhibit Na⁺/K⁺-

ATPase activity in Atlantic salmon gill tissue (Bystriansky et al., 2006). P_i liberated during ATP hydrolysis was determined by the method of Brotherus et al. (1981). Homogenate protein concentrations were determined using the Bradford method (Bradford, 1976). All Samples were run in duplicate. Gill Na^+/K^+ -ATPase activity was not determined for the 6 hour, 2 day and 7 day control groups. For the seawater to freshwater experiment all groups had a sample size of 8. For the freshwater to seawater experiment all groups had a sample size of 8 except for the seawater 4 days group (n=4) and seawater 14 days group (n=6).

2.8 Measurement of gill Na^+/K^+ -ATPase α subunit isoform mRNA expression

Total RNA was extracted from gill samples using TriZol isolation reagent (Invitrogen, Carlsbad, CA, USA) using the guanidine thiocyanate method (Chomczynski and Sacchi, 1987). Isolated total RNA was quantified spectrophotometrically using a NanoDrop 2000c spectrophotometer (Thermo Fisher Scientific Inc., Waltham, MA, USA). All RNA used was found to be of very high purity. RNA was stored at -80°C . First strand cDNA was synthesized from $5\mu\text{g}$ of total RNA using a high capacity cDNA reverse transcription kit (Applied Biosystems, Foster City, CA, USA). Quantitative RT-PCR (qRT-PCR) was performed on an ABI StepOnePlus Real-Time PCR system (Applied Biosystems). PCR reactions contained $2\mu\text{l}$ of cDNA, 150 pmol of each primer, and Universal SYBR Green Master Mix (Applied Biosystems). In the seawater to freshwater transfer experiment three different endogenous reference genes were tested. Eukaryotic elongation factor 1 alpha and beta-actin were not found to be stably expressed in all control and experimental groups; however, L13A ribosomal binding protein (L13A RBP) was found to be a suitable control gene. L13A RBP primers were developed by Hibbeler et al. (2008) and listed in Table 1, along with all other primers used in this study. In the freshwater to seawater transfer experiment four endogenous reference genes were tested. Eukaryotic elongation Factor 1 alpha, L13A RBP and ubiquitin were not found to be stably expressed in all control and experimental groups, therefore 18s ribosomal RNA was used as a control gene. 18s primers were developed by Katsiadaki et al. (2010). Homologous

genes from other teleost fish were used to find gene sequences in the three-spine stickleback genome. The genome of the three-spine stickleback contains four Na⁺/K⁺-ATPase α subunit isoforms, ATP1A1, ATP1A2, ATP1A3 (1 of 2) and ATP1A3 (2 of 2). The ATP1A1 isoform has four transcripts, which are 85-91% similar (at the cDNA level) with the greatest difference being in the fourth transcript. The ATP1A2 isoform only has one transcript. The ATP1A3 (1 of 2) isoform has four transcripts, which are 92-99% similar. The ATP1A3 (2 of 2) isoform has two transcripts, which are 99% similar. Primers were designed using Primer Express software (version 2.0.0; Applied Biosystems; see Table 1) to determine relative ATP1A1, ATP1A3 (1 of 2) and ATP1A3 (2 of 2) expression. Due to very few sequence differences between transcripts for each gene, primers could not be developed to distinguish individual transcripts. Therefore, general primers were designed to amplify all transcripts for each gene, with the exception of ATP1A1 in which primers were designed to recognize three of the four possible gene transcripts. Since the α 2 isoform is primarily muscle specific, primers for ATP1A2 were not developed. qRT-PCR reaction conditions were conducted as described previously (Bystriansky et al., 2006) and the presence of a single product was confirmed through a melt curve analysis. Negative control reactions for qRT-PCR were performed with original total RNA from several representative samples to determine potential genomic DNA contamination. For all genes monitored, the observed ratio of amplification was found to be at most 1:1400 compared to the same normally reverse transcribed sample, suggesting genomic contamination was negligible. The relative mRNA quantity of each gene for each gill sample was normalized to an endogenous reference (L13A RBP for sticklebacks of marine origin and 18s for sticklebacks of freshwater origin) and expressed relative to the mean value for the sticklebacks acclimated to seawater (control) for day 1 for those of marine origin or for the sticklebacks acclimated to freshwater (control) for day 1 for those of freshwater origin. For the seawater to freshwater experiment, all genes but ATP1A3 (1 of 2) (n=7) had a sample size of 8 per sampling time point. For the freshwater to seawater experiment, all genes had a sample size between 5 and 8 per sampling time

point, due to mortality of fish in the study. ATP1A3 (2 of 2) levels for the 14 days groups were not determined in the freshwater to seawater experiment due to a shortage of cDNA.

2.9 Statistical Analysis

All data are presented as means \pm S.E.M. An analysis of variance (ANOVA) was used to compare control and experimental groups for each parameter measured for each experiment. Post-hoc comparisons were made using Fisher's Least-Significant-Difference test. For all comparisons, $p < 0.05$ was considered significant. Since gill Na^+/K^+ -ATPase activity was not determined for the 6 hour, 2 day and 7 day control groups direct time matched comparisons could not be made. Analysis of gill Na^+/K^+ -ATPase activity revealed that activity did not change over time in the control groups ($p > 0.05$). Therefore, control data was pooled for comparison with individual experimental groups.

3. Results

3.1 Phylogenetic Analysis of Na^+/K^+ -ATPase α subunit isoforms

All stickleback isoforms grouped with other known Na^+/K^+ -ATPase α subunit isoforms as expected based on their annotations in the genome (Figure 1).

3.2 Seawater to Freshwater Transfer

All three-spine stickleback in this experiment survived transfer from seawater to freshwater and maintained a healthy appetite suggesting these fish were in good health throughout the experiment.

3.2.1 Plasma Chloride and Percent Muscle Water

Within six hours following freshwater transfer, three-spine stickleback plasma chloride levels were significantly reduced ($p < 0.001$) compared to control fish (Figure 2). These levels continued to decline reaching a minimum at 2 days after transfer to freshwater before increasing, but remained lower than control levels even after 7 and 14 days exposure. Plasma chloride levels in control fish

fluctuated significantly over the course of the experiment being slightly elevated at 6 hours ($p < 0.010$), 1 ($p < 0.004$) and 14 ($p < 0.021$) days compared with other controls.

Following transfer to freshwater, percent muscle water content was maintained relatively constant in three-spine stickleback except for a small decrease seen 4 days following transfer (Figure 3). Percent muscle water content remained constant in control fish throughout the experiment.

3.2.2 Gill Na^+/K^+ -ATPase Activity

Gill Na^+/K^+ -ATPase activity increased marginally over the first 2 days of freshwater acclimation before declining slightly at 4 days. Levels increased significantly ($p = 0.007$) by approximately 40% following 7 days of freshwater exposure before returning to near control levels by day 14 (Figure 4). Gill Na^+/K^+ -ATPase activity remained constant in control fish.

3.2.3 Gill Na^+/K^+ -ATPase α subunit isoform mRNA expression

ATP1A1

ATP1A1 mRNA levels declined significantly ($p < 0.001$) following freshwater exposure reaching a minimum at 4 days post transfer (36.5% decrease) (Figure 5). Levels in control groups did fluctuate slightly over time; however, these changes were not found to be statistically significant.

ATP1A3 (1 of 2) and ATP1A3 (2 of 2)

ATP1A3 (1 of 2) and ATP1A3 (2 of 2) mRNA levels appeared to be unchanged due to salinity change (Table 2). At 6 hours post transfer, ATP1A3 (1 of 2) levels in control fish were significantly higher ($p < 0.009$) than levels at other time points, but by day 1 these levels stabilized and remained unchanged for the remainder of the experiment.

3.3 Freshwater to Seawater Transfer

Eight fish were transferred to either control (freshwater) or seawater aquaria to be sampled at each of the 6 time points. Three fish from the 4 day and two fish from the 14 day seawater transferred groups died leaving a sample size of 5 and 6 respectively.

3.3.1 Plasma Chloride and Percent Muscle Water

Within 6 hours of seawater exposure, plasma chloride levels increased significantly ($p < 0.001$) compared to control fish (Figure 6). These levels continued to increase reaching a maximum at 1 day (55.4% increase) before returning to control levels by 4 days. Plasma chloride levels remained constant in control fish throughout the experiment.

Following transfer to seawater, muscle water content decreased significantly ($p < 0.001$) within 6 hours reaching a minimum at 1 day (Figure 7). These levels fluctuated slightly but not significantly between 4 and 7 days before returning to control levels by 14 days. Muscle water content in control fish fluctuated significantly over time ($p = 0.19$), being slightly elevated at 6 hours ($p < 0.001$) and slightly decreased at 4 ($p < 0.001$) and 7 ($p < 0.001$) days compared to other controls.

3.3.2 Gill Na^+/K^+ -ATPase Activity

Gill Na^+/K^+ -ATPase activity remained stable in control fish throughout the experiment. Following seawater transfer, activity increases by approximately 28% over time, however this change was not statistically significant (Figure 8).

3.3.3 Gill Na^+/K^+ -ATPase α subunit isoform mRNA expression

ATP1A1

Gill ATP1A1 mRNA levels increased significantly ($p < 0.001$) by approximately 3 fold within 1 day of seawater exposure before decreasing but remaining significantly ($p = 0.013$) elevated at 2 days (Figure

9). ATP1A1 expression returned to control levels by 4 days post transfer. Expression levels remained constant in control fish.

ATP1A3 (1 of 2) and ATP1A3 (2 of 2)

ATP1A3 (1 of 2) and ATP1A3 (2 of 2) mRNA levels appeared to be unchanged due to changes in salinity (Table 2). For ATP1A3 (1 of 2) there were significant increases compared to control levels at day 2 ($p < 0.001$) and 7 ($p = 0.008$) with levels remaining at the control level at day 4. Expression levels remained constant in control fish. Overall there was no obvious trend in the data. For ATP1A3 (2 of 2) the only significant difference was at day 1 ($p = 0.002$). The control levels remained constant.

4. Discussion

This study showed that both marine and freshwater populations of three-spine stickleback were able to successfully acclimate to changing salinity, suggesting they have not lost the full capacity to osmoregulate in either freshwater or seawater. This is consistent with other studies (Campeau et al., 1984; Audet, 1985; Guderley, 1994; Schaarschmidt et al., 1999). Based on mortality rates, plasma chloride levels and the regulation of muscle water content, it appears as though the freshwater to seawater transition may be more challenging. Fish of marine origin transferred to freshwater showed 100% survival over the 14 day experiment. In contrast, seawater exposure of freshwater stickleback resulted in approximately 90% survival rate, with all mortalities occurring within the first 48 hours. This is similar to Schaarschmidt et al. (1999) who reported mortality rates of approximately 5% following acclimation of a freshwater population of *G. aculeatus* from 10‰ to 35‰ seawater. Despite their slightly poorer performance, it appears that landlocked freshwater stickleback have retained much of their capacity to osmoregulate in seawater. The more limited capacity to osmoregulate in increased salinity has been shown in landlocked populations of several salmonids as well. Landlocked Arctic char exposed to seawater experience higher mortality rates compared to anadromous individuals (Staurnes

et al., 1992; Eliassen et al., 1998), a trend which is also seen in landlocked Atlantic salmon (Burton and Idler, 1984; Birt and Green, 1993) and sockeye salmon (Foote et al., 1992).

The seawater acclimation of freshwater stickleback may have also been less successful due to their significantly smaller size compared to the marine fish. In many salmonids, an increase in size has been correlated with an increase in salinity tolerance and may be related to the decrease in exposed surface area to volume as the fish increases in size (Hoar, 1976). Parry (1958, 1960a) showed that in Atlantic salmon of the same age but different sizes, larger individuals have improved survival following exposure to seawater. Other salmonids such as brown trout, *Salmo trutta* (Parry, 1958, 1960a), rainbow trout, *Oncorhynchus mykiss* (Parry, 1958, 1960a; Conte and Wagner, 1965), chinook salmon, *Oncorhynchus tshawytscha* (Wagner et al., 1969), and brook trout, *Salvelinus fontinalis* (McCormick and Naiman, 1984), also exhibit the trend of larger animals having improved survival in seawater. A similar trend has also been observed in tilapia (*Oreochromis aureus*, *O. niloticus* and a *O. mossambicus* hybrid), which show a correlation between larger body size and tolerance to higher salinities (Watanabe et al., 1985).

Overall, the stickleback that survived the salinity acclimation experiments appeared to do well based on the osmoregulatory indicators of plasma chloride and muscle water content levels. Teleost fish acclimating to different salinities go through a period of osmoregulatory adjustment that consists of an initial crisis phase followed by a stabilization phase. During acclimation of euryhaline fish from seawater to freshwater, there is typically a rapid decrease in plasma ion levels, which over time, are regulated back up towards normal levels due to active ion uptake by the gills (Gordon, 1959). In this study, marine three-spine stickleback transferred to freshwater initially showed a rapid decline in plasma chloride levels, which reached a minimum after 2 days before regulating these levels up to a new steady state by 7 days. Freshwater acclimated fish, on the other hand, experience a rapid increase in plasma ion levels

upon exposure to seawater which are regulated back toward original levels due to active ion secretion by the gills (Lotan, 1973). Freshwater stickleback transferred to seawater experienced a rapid increase in plasma chloride levels that reached a maximum after three days but were brought back to control levels by day 4. In this study, stickleback were able to regain ionic homeostasis slightly faster than seen by Schaarschmidt et al. (1999), who reported it takes 7 days for freshwater and brackish water populations to acclimate to 35‰ seawater. Muscle water content has been shown to be inversely related to plasma ion levels (Sakamoto et al., 2001) and is therefore a useful parameter to measure to indicate osmoregulatory capacity in small fish from which it is difficult to obtain large quantities of plasma. The muscle water content of freshwater transferred marine fish initially rose, although not significantly, before decreasing significantly at 4 days before returning to control levels. Similar patterns of muscle water regulation have been seen in other species such as Atlantic salmon, *Salmo salar* (Parry, 1960b; Handeland et al., 1998), brown trout, *Salmo trutta* (Madsen, 1990b; Tipsmark et al., 2002), medaka, *Oryzias latipes* (Sakamoto et al., 2001), rainbow trout, *O. mykiss* (Madsen and Naamansen, 1989; Madsen, 1990a), and whitefish, *Coregonus lavaretus* (Madsen et al., 1996), during acclimation to seawater. The muscle water content of seawater transferred freshwater stickleback decreased significantly during the first 2 days of acclimation before returning to control levels by 14 days. A similar pattern has been observed in other species including Arabian killifish, *Aphanius dispar* (Lotan, 1973), Atlantic salmon, *S. salar* (Parry, 1960b), black seabream, *Mylio macrocephalus* (Kelly et al., 1999), sea bass, *Dicentrarchus labrax* (Jensen et al., 1998), and southern flounder, *Paralichthys lethostigma* (Tipsmark et al., 2008), during acclimation to freshwater. Overall, plasma chloride levels and muscle water content stabilized at or near control levels within the timeframe of our experiment for both transfers, suggesting that marine and freshwater populations have retained the ability to successfully acclimate to changing salinity, consistent with previous studies (Campeau et al., 1984; Audet, 1985; Guderley, 1994; Schaarschmidt et al., 1999).

The regulation of whole body ion and water content is linked to the ability of the gill to either actively uptake or secrete ions, depending on the salinity of the fish's environment. Gill Na^+/K^+ -ATPase activity is central to both of these ion exchange mechanisms. Many euryhaline fish increase their gill Na^+/K^+ -ATPase activity following transfer to either increased or decreased salinity (Lasserre, 1971; McCormick and Saunders, 1987). Lasserre (1971) described this phenomenon as a salinity dependent 'u-shaped' regulation of gill Na^+/K^+ -ATPase activity. Most anadromous salmonid species increase gill Na^+/K^+ -ATPase activity (Folmar and Dickhoff, 1980) during their freshwater to seawater migration. Many other euryhaline species also increase gill Na^+/K^+ -ATPase activity upon exposure to seawater including the killifish, *Fundulus heteroclitus* (Scott et al., 2004a), flounder, *Plauchthys flesus* (Stagg and Shuttleworth, 1982) and *P. lethostigma* (Tipsmark et al., 2008), Japanese eel, *Anguilla japonica* (Utida et al., 1971), striped bass, *Morone saxatilis* (Tipsmark et al., 2004), and three-spine stickleback, *G. aculeatus* (Schaarschmidt et al., 1999). Some of these species as well as others also increase gill Na^+/K^+ -ATPase activity upon entry into freshwater including Arctic char, *Salvelinus alpinus* (Bystriansky et al., 2007b), Atlantic salmon, *S. salar* (Bystriansky and Schulte, 2011), flounder, *P. flesus* (Stagg and Shuttleworth, 1982) and *G. mirabilis* (Doneen, 1981), killifish, *F. heteroclitus* (Scott et al., 2004a; Scott et al., 2004b), milkfish, *Chanos chanos* (Lin et al., 2003), mullet, *Mugil cephalis* (Ciccotti et al., 1994) and *Chelon labrosus* (Gallis et al., 1979), pupfish, *Cyprinodon salinus* (Stuenkel and Hillyard, 1980), sea bass, *D. labrax* (Lasserre, 1971; Jensen et al., 1998), sea bream, *M. macrocephalus* (Kelly et al., 1999), and striped bass, *M. saxatilis* (Tipsmark et al., 2004). Based on the wide variety of euryhaline species that display this 'u-shaped' regulation, it was expected that the stickleback would increase gill Na^+/K^+ -ATPase activity during both salinity transfer experiments. Marine stickleback increased gill Na^+/K^+ -ATPase activity approximately 40% within 7 days of exposure to freshwater. This result is interesting as it supports the idea that the gill Na^+/K^+ -ATPase plays an important role in the active uptake of ions in freshwater environments which has previously been described as 'uncertain' (Perry, 1997) or 'unclear'

(Evans et al., 2005). No significant increase in gill Na^+/K^+ -ATPase activity was observed in freshwater stickleback upon exposure to seawater, though a trend of increasing activity is present. This result was surprising since a previous study that transferred stickleback from 10‰ to 35‰ seawater observed a significant increase in gill Na^+/K^+ -ATPase activity (Schaarschmidt et al., 1999).

The three-spine stickleback genome contains genes for multiple Na^+/K^+ -ATPase α subunit isoforms, ATP1A1, ATP1A2, ATP1A3 (1 of 2) and ATP1A3 (2 of 2). Similar to the expression pattern seen in other fish including rainbow trout (Richards et al., 2003), tilapia (Lee et al., 1998) and *Trematomus spp* (Guynn et al., 2002), we found that stickleback express mRNA for ATP1A1, ATP1A3 (1 of 2) and ATP1A3 (2 of 2) in their gills. The mRNA expression levels of ATP1A3 (1 of 2) and ATP1A3 (2 of 2) in the gills of stickleback did not change in response to either increased or decreased salinity. This is similar to observations by Richards et al. (2003) who report no change in $\alpha 3$ expression in rainbow trout gills during seawater acclimation. Only the stickleback ATP1A1 isoform showed a change in mRNA expression in response to changing salinity. Upon exposure of marine stickleback to freshwater the mRNA levels of ATP1A1 decreased significantly. The opposite pattern was seen in freshwater stickleback exposed to seawater, where mRNA levels of ATP1A1 increased by approximately 3 fold within 1 day. This mRNA expression pattern is similar to that of the $\alpha 1b$ isoform found in salmonid fishes (Richards et al., 2003; Bystriansky et al., 2006; Bystriansky et al., 2007b; Bystriansky and Schulte, 2011) and tilapia (Tipsmark et al., 2011). This suggests that the ATP1A1 isoform may play a prominent role in the secretion of ions in marine habitats. In this study, no α subunit isoform was found in the stickleback to have a similar expression pattern to the $\alpha 1a$ isoform expression seen in salmonid fishes, which increases expression in freshwater and decreases expression in seawater and is thought to play a significant role in ion uptake (Richards et al., 2003). This lack of up-regulation of an α subunit isoform is especially interesting as we see a significant increase in gill Na^+/K^+ -ATPase activity. Previous studies observed that an increase in gill Na^+/K^+ -ATPase activity is generally preceded or accompanied by an

increase in α subunit mRNA expression during salinity transfer. Increases in α subunit mRNA expression were seen in Atlantic salmon (D'Cotta et al., 2000; Singer et al., 2002), brook trout (Madsen et al., 1995; Seidelin et al., 2000) and sea bass (Jensen et al., 1998). However, these studies used probes or primers that were not isoform specific and in most cases designed from sequences of other vertebrate species. At least in the case of the Atlantic salmon, the methods used to identify this general increase in gill Na^+/K^+ -ATPase α subunit mRNA expression were hiding the reciprocal expression of $\alpha 1a$ and $\alpha 1b$ isoforms. The inability to create primers to distinguish between three of the four ATP1A1 transcripts and to recognize the fourth ATP1A1 transcript may be the reason we did not observe an increase in isoform expression similar to that of the $\alpha 1a$ isoform in salmonid fishes.

5. Conclusions

Overall both marine and freshwater three-spine stickleback were able to successfully acclimate to changing salinity based on mortality rates, regulation of plasma chloride levels and regulation of muscle water content, although the freshwater stickleback seem to have a lower capacity to osmoregulate. Acclimation to freshwater by marine stickleback is associated with an increase in gill Na^+/K^+ -ATPase ATP1A1 isoform expression while acclimation to seawater by freshwater stickleback entails an increase in gill Na^+/K^+ -ATPase activity accompanied by a decrease in gill Na^+/K^+ -ATPase ATP1A1 isoform expression. This suggests that the ATP1A1 isoform plays an important role in ion secretion in marine habitats. A stickleback α isoform with an expression pattern similar to the salmonid $\alpha 1a$ has yet to be identified.

Acknowledgments

This research was funded by a DePaul University URC Grant to JSB. We would like to thank Callum Kingwell for collecting the fish. We would also like to thank Mark Scott for help with primer design and Mattina Alonge, Penelope Antonopoulos, Casey Murphy and Mauricio Urbina Foneron for assistance with sampling and lab analysis.

Tables and Figures

Table 1: Quantitative RT-PCR Primer Sequences

Gene	Forward Primer	Reverse Primer
ATP1A1	5'-GCGGCGCCTCCTTTG-3'	5'-GTTACACAGCCCAGCAATTCG-3'
ATP1A3 (1 of 2)	5'-ATGGCTGCAAGGTCGATAACTC-3'	5'-GTCGGGTGACCTGCTCTGA-3'
ATP1A3 (2 of 2)	5'-GGGTCTGCTCGCCACAGT-3'	5'-GCGAGCCATTGCTTAGC-3'
L13A RBP	5'-CACCTTGGTCAACTTGAACAGTG-3'	5'-TCCCTCCGCCCTACGAC-3'
18s rRNA	5'-CGGCTACCACATCCAAGGAA-3'	5'-TCCTGTATTGTTATTTTCGTCACCT-3'

Table 2: mRNA levels of Na⁺/K⁺-ATPase α 3a and α 3b isoforms in the gill of three-spine stickleback acclimated to either seawater (32‰ – controls) and following exposure to freshwater and three-spine stickleback acclimated to freshwater (controls) and following exposure to seawater (32‰) over a total period of 14 days

mRNA	Exposure Time					
	6 Hours	1 Day	2 Days	4 Days	7 Days	14 Days
Seawater to Freshwater Transfer						
Na ⁺ /K ⁺ -ATPase ATP1A3 (1 of 2)						
FW	0.78±0.06*	0.81±0.10*	0.82±0.06	0.72±0.08	0.82±0.09	0.72±0.02
SW	1.31±0.16 ^a	1.00±0.08 ^b	0.94±0.05 ^b	0.85±0.04 ^{b,c}	0.93±0.06 ^b	0.72±0.07 ^c
Na ⁺ /K ⁺ -ATPase ATP1A3 (2 of 2)						
FW	0.70±0.10	0.96±0.14	1.32±0.11	1.12±0.16	1.02±0.15	1.63±0.51
SW	1.32±0.13	1.00±0.11	1.62±0.30	1.54±0.34	1.50±0.16	0.91±0.10
Freshwater to Seawater Transfer						
Na ⁺ /K ⁺ -ATPase ATP1A3 (1 of 2)						
FW	0.58±0.04	1.00±0.21	0.73±0.10	0.84±0.08	0.73±0.10	0.64±0.05
SW	0.77±0.08 ^a	1.28±0.10 ^b	1.35±0.25 ^{*b}	0.85±0.08 ^c	1.23±0.13 ^{*b}	0.87±0.08 ^c
Na ⁺ /K ⁺ -ATPase ATP1A3 (2 of 2)						
FW	0.60±0.06 ^a	1.00±0.22 ^b	0.80±0.10 ^{a,b}	1.04±0.14 ^b	0.95±0.09 ^{a,b}	n.d.
SW	0.55±0.04 ^a	0.50±0.10 ^{*a}	0.99±0.13 ^b	1.23±0.12 ^b	1.21±0.17 ^b	n.d.

mRNA expression is presented relative to the expression of a control gene (LI3A RBP for the seawater to freshwater transfer experiment and 18s rRNA for the freshwater to seawater experiment) and normalized relative to the corresponding 1 day control group. Means ± s.e.m., N=8 for each group in the seawater to freshwater transfer experiment and N=5 to 8 for each group in the freshwater to seawater transfer experiment. n.d., parameter not determined. * indicates a significant difference between paired control and experimental time points. Within transfer groups (FW or SW), different superscripted letters indicate significant differences over time.

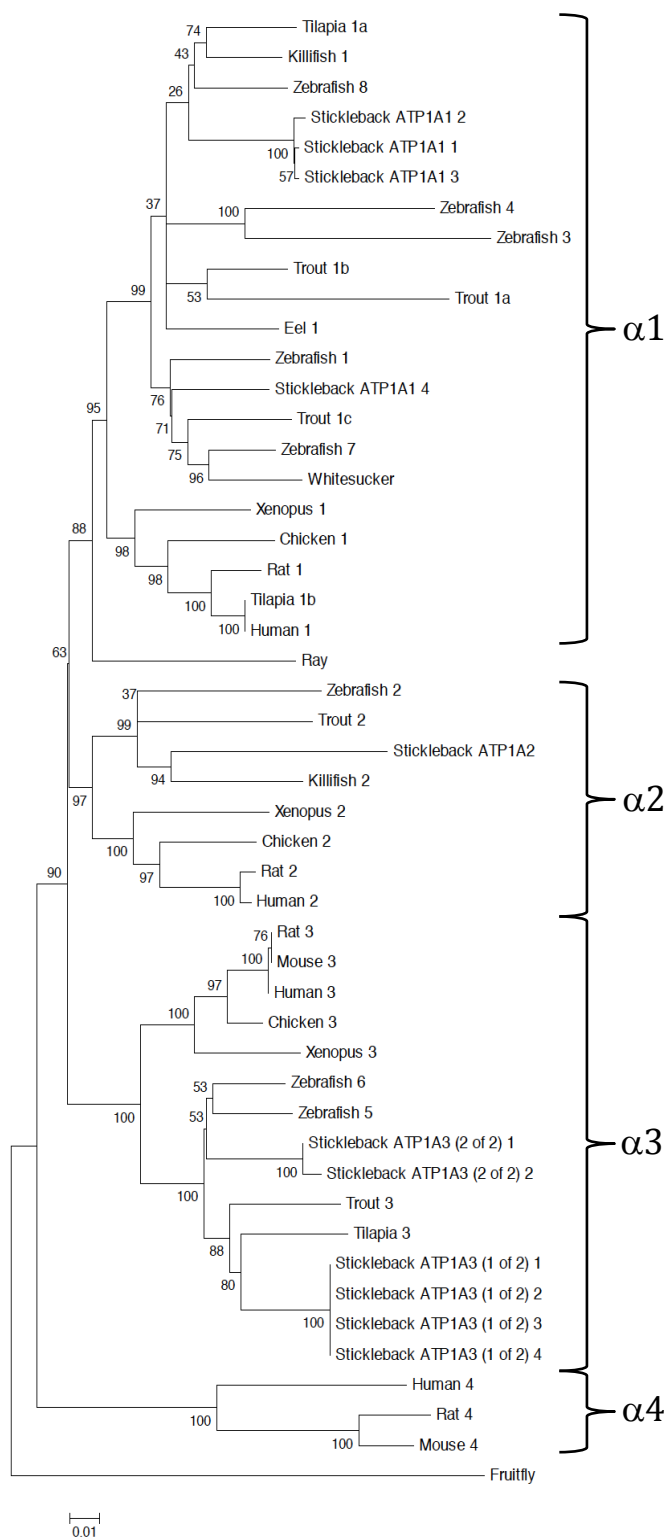

Figure 1: Phylogenetic analysis of Na^+/K^+ -ATPase α subunit isoform protein sequences. Numbers presented at each branch point represent bootstrap values from 500 replicates. Fruittly Na^+/K^+ -ATPase was used as an out-group.

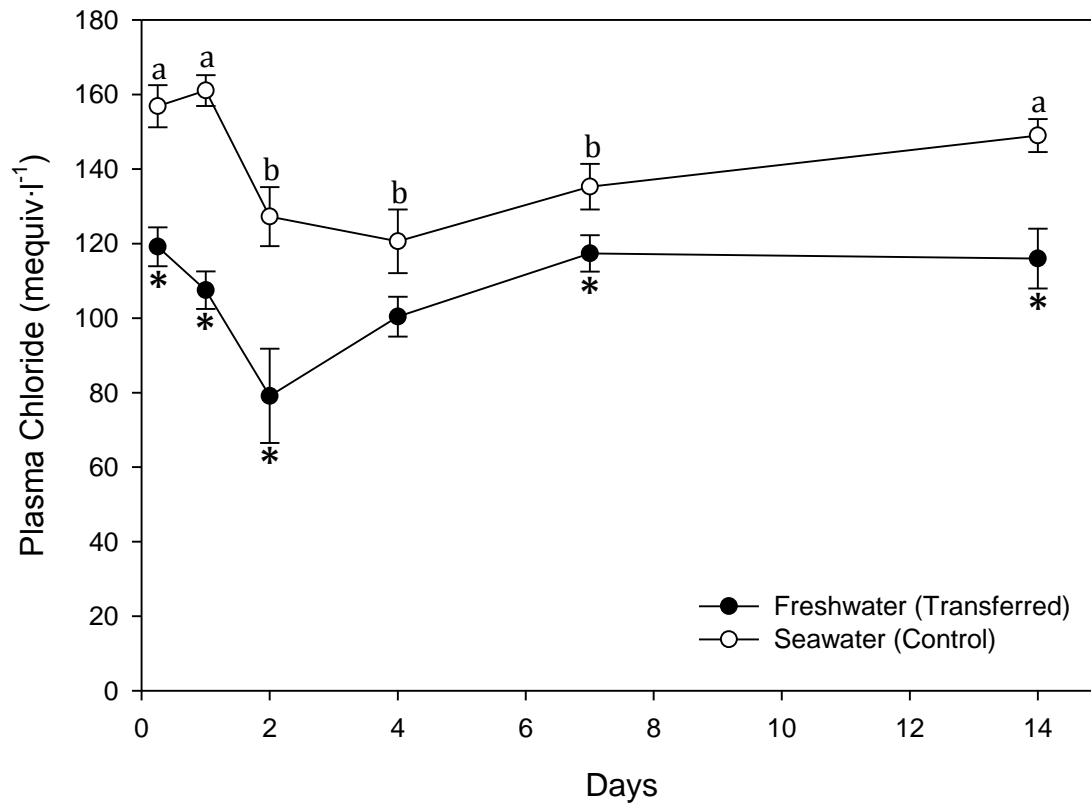

Figure 2: Plasma chloride levels (mequiv·l⁻¹) in marine three-spine stickleback following transfer to seawater (32‰)(control) or freshwater for 14 days. * indicates significantly different from time matched control level. Within control, different superscripted letters indicate significant differences over time.

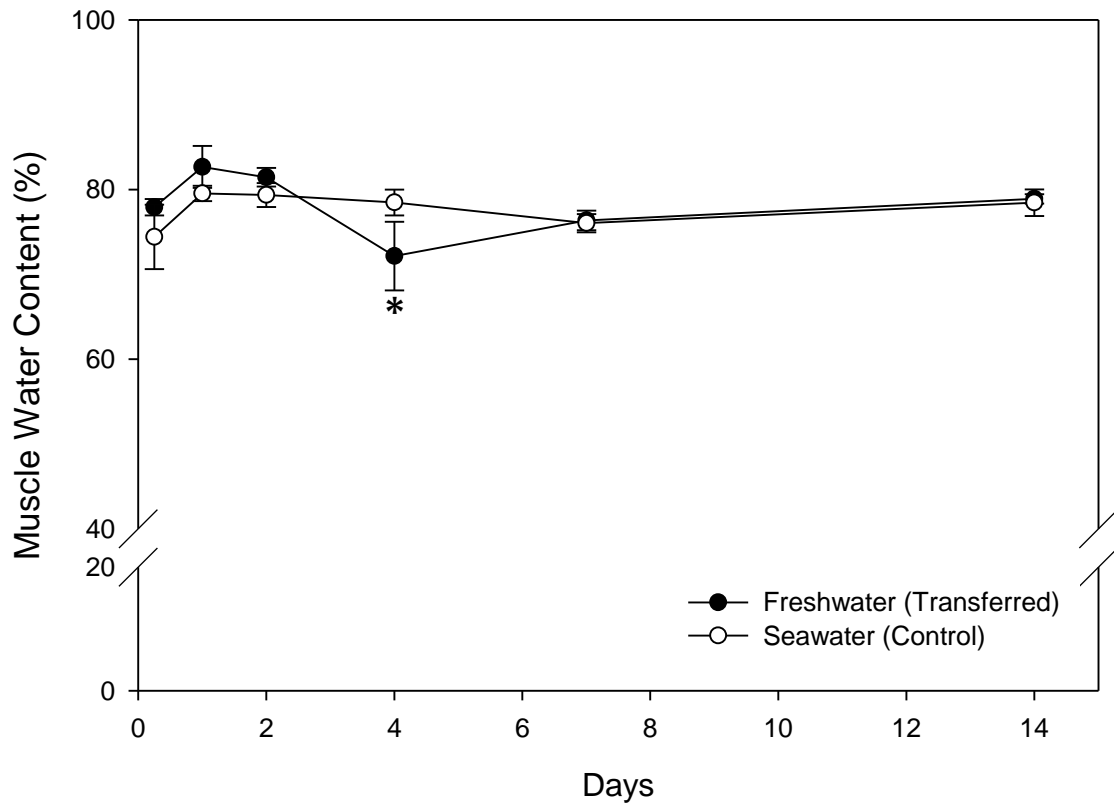

Figure 3: Muscle water content (%) in marine three-spine stickleback following transfer to seawater (32‰) (control) or freshwater for 14 days. * indicates significantly different from time matched control level.

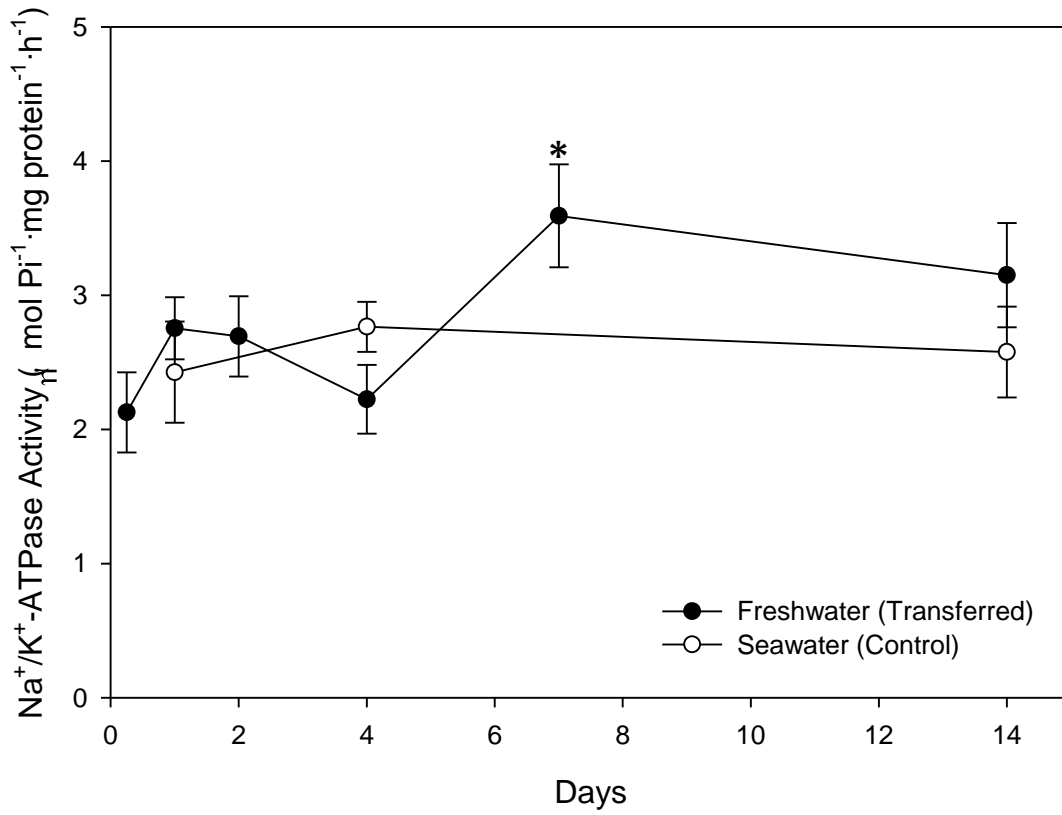

Figure 4: Gill Na⁺/K⁺-ATPase activity in marine three-spine stickleback following transfer to seawater (32‰) (control) or freshwater for 14 days. * indicates significantly different from pooled seawater control fish.

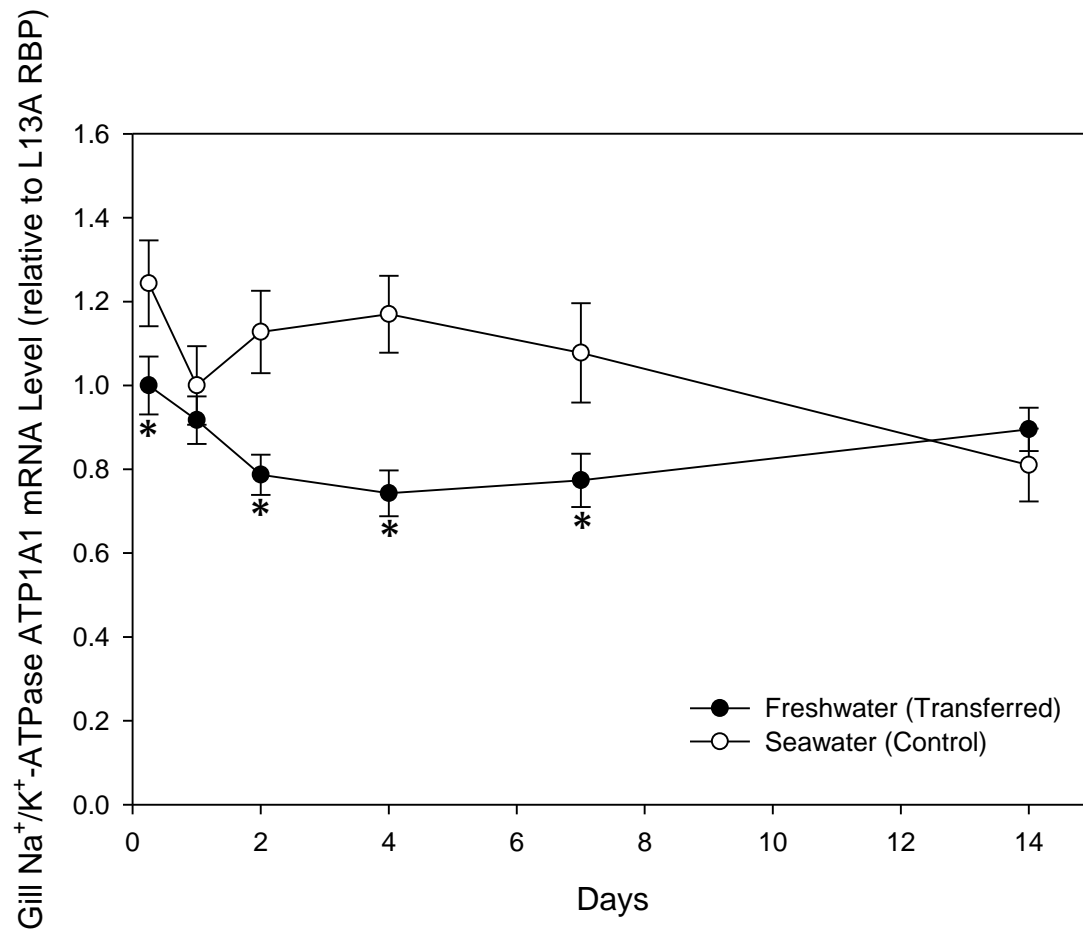

Figure 5: Gill mRNA levels of Na⁺/K⁺-ATPase isoform ATP1A1 in marine three-stickleback following transfer to seawater (32‰) (control) or freshwater for 14 days. * indicates significantly different from time matched control level.

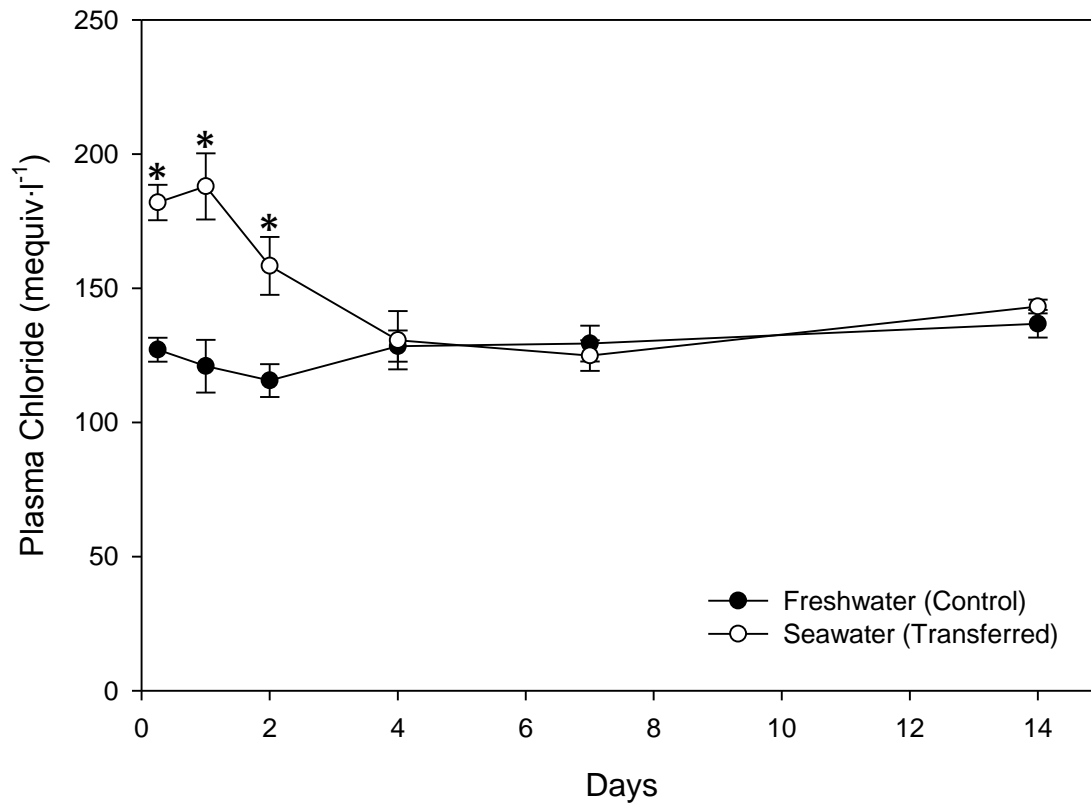

Figure 6: Plasma chloride levels (mequiv·l⁻¹) in freshwater three-spine stickleback following transfer to freshwater (control) or seawater (32‰) for 14 days. * indicates significantly different from time matched control level.

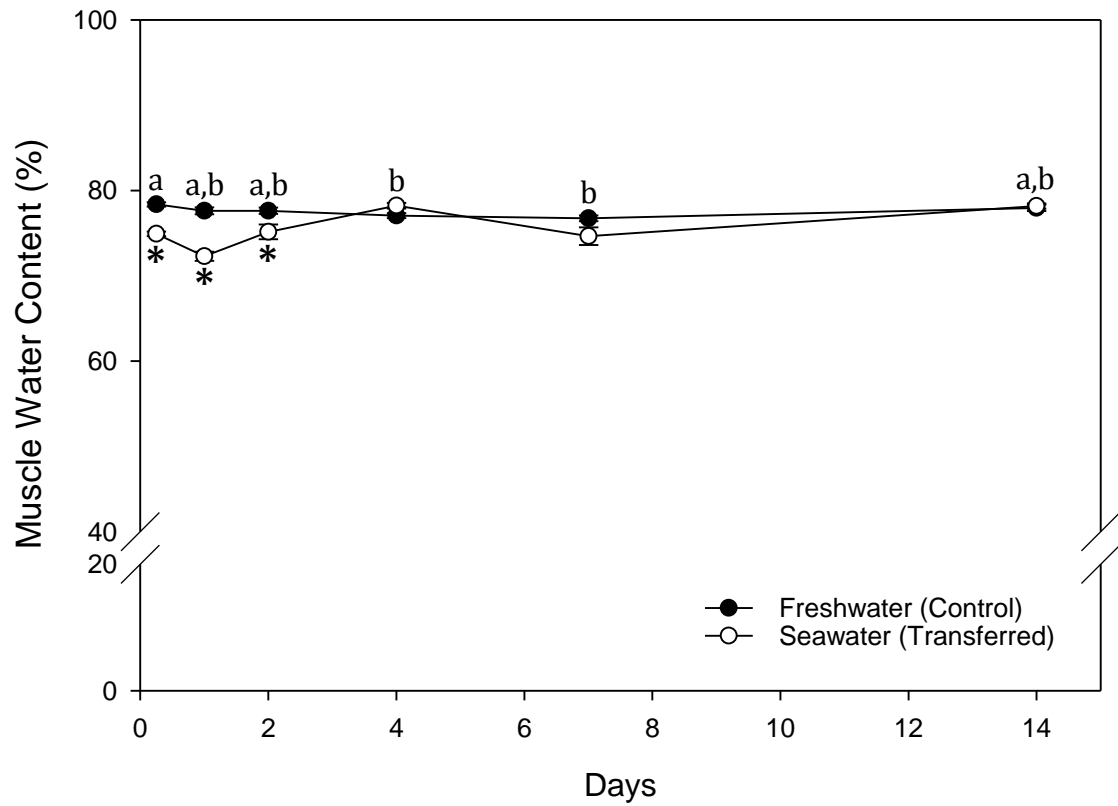

Figure 7: Muscle water content (%) in freshwater three-spine stickleback following transfer to freshwater (control) or seawater (32‰) for 14 days. * indicates significantly different from time matched control level. Within control, different superscripted letters indicate significant differences over time.

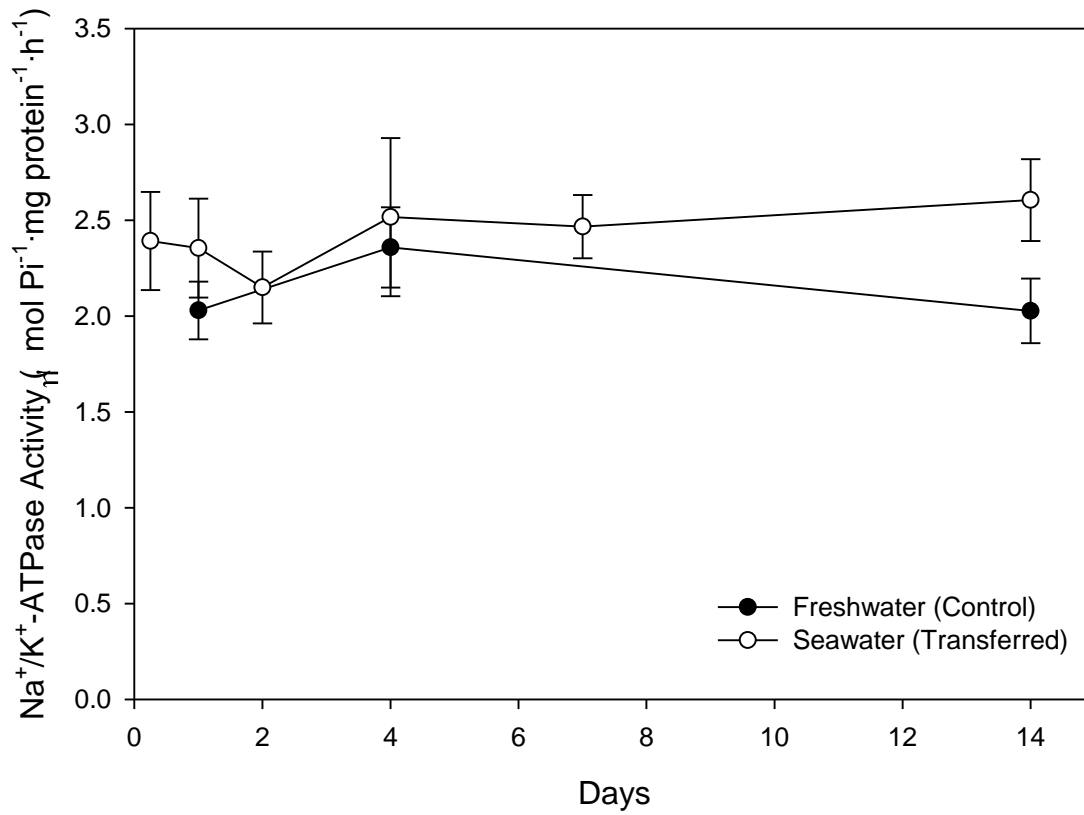

Figure 8: Gill Na⁺/K⁺-ATPase activity in freshwater three-spine stickleback following transfer to freshwater (control) or seawater (32‰) for 14 days. * indicates significantly different from pooled seawater control fish.

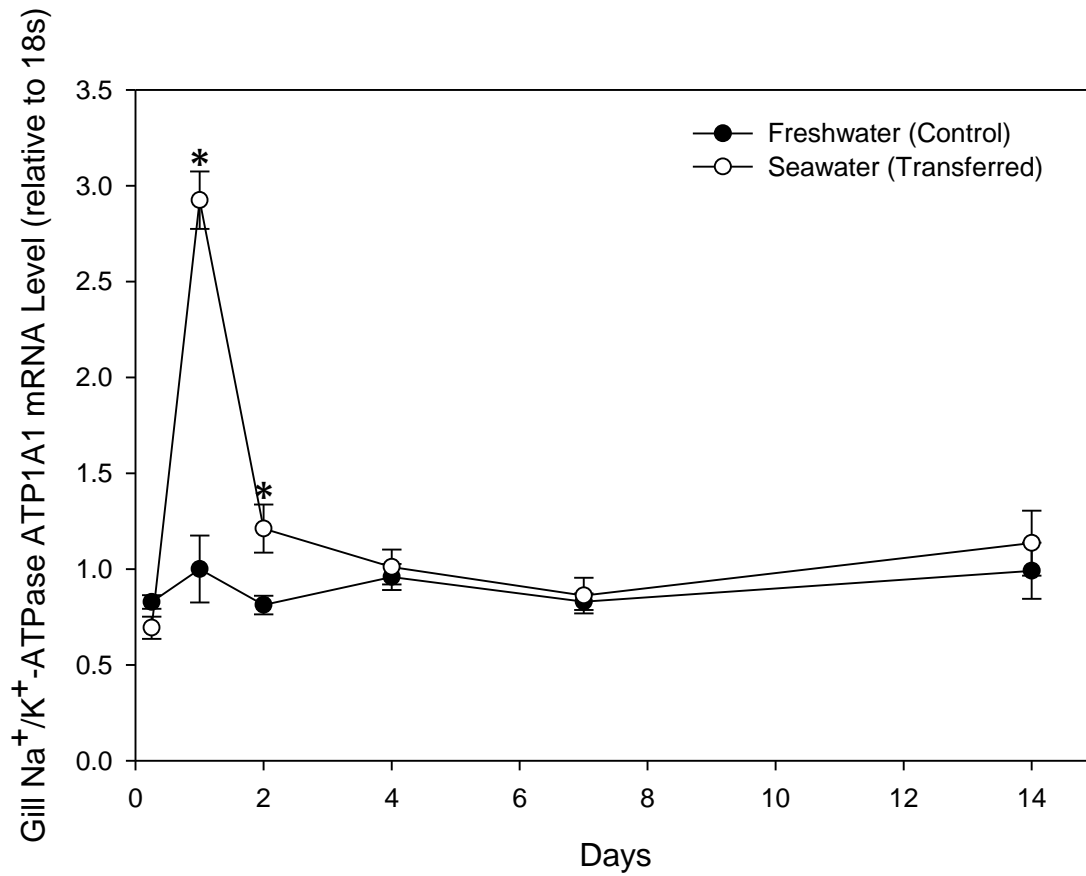

Figure 9: Gill mRNA levels of Na⁺/K⁺-ATPase isoform ATP1A1 in freshwater three-spine stickleback following transfer to freshwater (control) or seawater (32‰) for 14 days. * indicates significantly different from time matched control level.

Chapter 3: General Discussion

A vast amount of research has been done on the three-spine stickleback in regards to behavior, morphology, ecology and evolution as well as speciation and it has become a model species in these fields. This has resulted in thousands of published papers and several books (Wotton, 1984; Bell and Foster, 1994; Östlund-Nilsson et al., 2007). Much of the research on salinity tolerance and osmoregulation in the three-spine stickleback has focused on the lateral plate morph rather than on the life history of the fish or how seasonal changes in salinity tolerance are controlled (Guderley, 1994). Very little of this research has investigated the physiology of the gills during salinity acclimation. To my knowledge this is the first study to explore the independent Na^+/K^+ -ATPase α subunit isoform regulation in the three-spine stickleback during acclimation to different salinities.

Prior to beginning this study, independent regulation of α subunit isoforms in response to changing salinity had only been observed in salmonids (Richards et al., 2003; Shrimpton et al., 2005; Bystriansky et al., 2006; Bystriansky et al., 2007b; Bystriansky and Schulte, 2011). This observation led to the question of whether this phenomenon occurs in other euryhaline teleost species during acclimation to changing salinity. The three-spine stickleback was chosen as the model system in this study to investigate this phenomenon because of their eurhalinity and fully sequenced genome. While completing this study, a similar study was published showing that tilapia also display independent regulation of α subunit isoforms (Tipsmark et al., 2011). The results of this study confirm that this phenomenon also occurs in the three-spine stickleback. Although we were not the first to discover this phenomenon in a non-salmonid species, it is clear that based on this study and the tilapia study that the question of whether independent regulation of α subunit isoforms occurs in other species was worth investigating.

This study also confirmed that the landlocked population of three-spine stickleback used in this study has retained their ability to acclimate to seawater. Freshwater stickleback acclimated to seawater had a survival rate of approximately 90%. In contrast, landlocked salmonids exposed to seawater

experience much higher mortality rates, in many cases greater than 70% mortality, compared to their anadromous counterparts. This trend has been observed in Arctic char (Staurnes et al., 1992; Eliassen et al., 1998), Atlantic salmon (Burton and Idler, 1984; Birt and Green, 1993) and sockeye salmon (Foote et al., 1992). In the case of landlocked Arctic char their reduced osmoregulatory ability to acclimate to seawater may be due to their failure to up-regulate $\alpha 1b$ (Bystriansky et al., 2007a) which is thought to play an important role in ion secretion in marine habitats. The acclimation of freshwater stickleback to seawater did involve the up-regulation of ATP1A1, which has an expression pattern similar to $\alpha 1b$ in salmonids and tilapia when exposed to seawater. Since freshwater stickleback were able to up-regulate the α subunit isoform thought to be important in ion secretion, their reduced survival compared to marine stickleback may have been related more to their significantly smaller size than other factors.

Gill Na^+/K^+ -ATPase activity has been observed to show a 'u-shaped' regulation pattern in which activity increases in response to acclimation to both increased and decreased salinity (Lasserre, 1971). Marine stickleback transferred to freshwater showed a significant increase in gill Na^+/K^+ -ATPase activity. Although not significant, freshwater stickleback transferred to seawater did show a general trend of activity increasing over time (~ 28%). As mentioned earlier this result is surprising as a previous study that transferred stickleback from 10‰ to 35‰ seawater observed an increase in gill Na^+/K^+ -ATPase activity (Schaarschmidt et al., 1999). The increase in activity in this study may have been due to the higher salinity that the stickleback were transferred to. Tilapia, *O. mossambicus*, transferred to various salinities have been found to only drastically increase gill Na^+/K^+ -ATPase activity when in salinities of 35‰ and higher (Kültz et al., 1992). This may explain the lack of increase in gill Na^+/K^+ -ATPase activity in freshwater stickleback transferred to 32‰ seawater in the present study.

This study also confirms the importance of the gill Na^+/K^+ -ATPase in freshwater ionoregulation. Acclimation to freshwater by marine stickleback appears to require a significant increase in gill Na^+/K^+ -ATPase activity. This observation supports the 'classic model' of ionoregulation in freshwater teleosts

and suggests that stickleback may not rely on the apical V-type H⁺-ATPase found in the 'current model' to generate favorable electrochemical gradients to uptake ions as much as other species. This is further supported by the lack of an obvious ENaC in the genome, while several forms of the NHE are present. The three-spine stickleback may be a useful model organism for further examination of the 'classic model'.

This study has provided the first evidence of independent isoform regulation in the three-spine stickleback. It has also show that landlocked freshwater populations have retained their ability to acclimate to seawater as well as provided support for the role of the Na⁺/K⁺-ATPase in ion uptake in freshwater habitats. The three-spine stickleback has been a useful model organism in a variety of other biological disciplines and from the results of this study it is clear that this usefulness can extend into other areas of study including further research into the physiological changes in the gills during salinity acclimation.

Literature Cited

- Audet, C.F., Gerard; Guderley, Helga, 1985. Salinity Preference of Four Sympatric Species of Sticklebacks (Pisces: Gasterosteidae) during Their Reproductive Season. *Copeia* 1985, 209-213.
- Avella, M., Bornancin, M., 1989. A New Analysis of Ammonia and Sodium Transport Through the Gills of the Freshwater Rainbow Trout (*Salmo Gairdneri*). *J Exp Biol* 142, 155-175.
- Baggerman, B., 1957. An experimental study on the timing of breeding and migration in the three-spined stickleback, *Gasterosteus aculeatus* L. *Archives Néerlandaises de Zoologie* 12, 105-318.
- Bath, R.N., Eddy, F.B., 1979. Salt and Water Balance in Rainbow Trout (*Salmo Gairdneri*) Rapidly Transferred From Fresh Water to Sea Water. *J Exp Biol* 83, 193-202.
- Bell, M.A., 1994. Palaeobiology and evolution of the threespine stickleback, in: M.A. Bell, S.A. Foster (Eds.), *The Evolutionary Biology of the Threespine Stickleback*. Oxford University, Oxford, 438.
- Bell, M.A., 1995. Intraspecific Systematics of *Gasterosteus aculeatus* Populations: Implications for Behavioral Ecology. *Behaviour* 132, 1131-1152.
- Bell, M.A., 2001. Lateral plate evolution in the threespine stickleback: getting nowhere fast. *Genetica* 112-113, 445-461.
- Bell, M.A., Foster, S.A., 1994. *The Evolutionary Biology of the Threespine Stickleback*. Oxford University, Oxford, 571.
- Biether, M., 1970. Die Chloridzellen de Stichlings. *Zeitschrift für Zellforschung* 107, 99-108.
- Birt, T.P., Green, J.M., 1993. Acclimation to seawater of dwarf nonanadromous Atlantic salmon, *Salmo salar*. *Can J Zool* 71, 1912-1916.
- Blanco, G., 2005. Na,K-ATPase Subunit Heterogeneity as a Mechanism for Tissue-Specific Ion Regulation. *Seminars in Nephrology* 25, 292-303.
- Blanco, G., Mercer, R.W., 1998. Isozymes of the Na-K-ATPase: heterogeneity in structure, diversity in function. *Am J Physiol* 275, F633-650.
- Bornancin, M., DeRenzi, G., 1972. Evolution of the branchial sodium outflux and its components, especially the Na/K exchange and the Na-K dependent ATPase activity during adaptation to sea water in *Anguilla anguilla*. *Comp Biochem Physiol* 43A, 577-591.
- Bradford, M.M., 1976. A Rapid and Sensitive Method for the Quantitation of Microgram Quantities of Protein Utilizing the Principle of Protein-Dye Binding. *Anal Biochem*, 248-254.
- Brotherus, J.R., Moller, J.V., Jorgensen, P.L., 1981. Soluble and active renal Na, K-ATPase with maximum protein molecular mass 170,000 +/- 9,000 daltons; formation of larger units by secondary aggregation. *Biochem Biophys Res Commun* 100, 146-154.

- Burton, M.P., Idler, D.R., 1984. Can Newfoundland landlocked salmon, *Salmo salar* L., adapt to sea water? *J Fish Biol* 24, 59-64.
- Bystriansky, J.S., Frick, N.T., Richards, J.G., Schulte, P.M., Ballantyne, J.S., 2007a. Failure to up-regulate gill Na⁺,K⁺-ATPase alpha-subunit isoform alpha1b may limit seawater tolerance of land-locked Arctic char (*Salvelinus alpinus*). *Comp Biochem Physiol A Mol Integr Physiol* 148, 332-338.
- Bystriansky, J.S., Frick, N.T., Richards, J.G., Schulte, P.M., Ballantyne, J.S., 2007b. Wild Arctic char (*Salvelinus alpinus*) upregulate gill Na⁺,K⁺-ATPase during freshwater migration. *Physiological and Biochemical Zoology* 80, 270-282.
- Bystriansky, J.S., Kaplan, J.H., 2007. Sodium pump localization in epithelia. *J Bioenerg Biomembr* 39, 373-378.
- Bystriansky, J.S., Richards, J.G., Schulte, P.M., Ballantyne, J.S., 2006. Reciprocal expression of gill Na⁺/K⁺-ATPase alpha-subunit isoforms alpha1a and alpha1b during seawater acclimation of three salmonid fishes that vary in their salinity tolerance. *J Exp Biol* 209, 1848-1858.
- Bystriansky, J.S., Schulte, P.M., 2011. Changes in gill H⁺-ATPase and Na⁺/K⁺-ATPase expression and activity during freshwater acclimation of Atlantic salmon (*Salmo salar*). *J Exp Biol* 214, 2435-2442.
- Campeau, S., Guderley, H., Fitzgerald, G., 1984. Salinity tolerances and preferences of fry of two species of sympatric sticklebacks: possible mechanisms of habitat segregation. *Can J Zool* 62, 1048-1051.
- Chomczynski, P., Sacchi, N., 1987. Single-step method of RNA isolation by acid guanidinium thiocyanate-phenol-chloroform extraction. *Anal Biochem* 162, 156-159.
- Ciccotti, E., Marino, G., Pucci, P., Cataldi, E., Cataudella, S., 1994. Acclimation trial of *Mugil cephalus* juveniles to freshwater: morphological and biochemical aspects. *Environ Biol Fishes* 43, 163-170.
- Conte, F.P., Wagner, H.H., 1965. Development of osmotic and ionic regulation in juvenile steelhead trout *Salmo Gairdneri*. *Comp Biochem Physiol* 14, 603-620.
- D'Cotta, H., Valotaire, C., le Gac, F., Prunet, P., 2000. Synthesis of gill Na⁽⁺⁾-K⁽⁺⁾-ATPase in Atlantic salmon smolts: differences in alpha-mRNA and alpha-protein levels. *Am J Physiol Regul Integr Comp Physiol* 278, R101-110.
- Dobson, M., Frid, C., 2009. *Ecology of Aquatic Systems*, 2nd ed. Oxford University Press, New York, 10-14.
- Doneen, B., 1981. Effects of adaptation to sea water, 170% sea water and to fresh water on activities and subcellular distribution of branchial Na⁺-K⁺-ATPase, low- and high affinity Ca⁺⁺⁺-ATPase, and ouabain-insensitive ATPase in *Gillichthys mirabilis*. *J Comp Physiol* 145, 51-61.
- Dunel-Erb, S., Laurent, P., 1980. Ultrastructure of marine teleost gill epithelia: SEM and TEM study of the chloride cell apical membrane. *J Morphol* 165, 175-186.

- Eddy, F.B., 1982. Osmotic and Ionic Regulation in Captive Fish with Particular Reference to Salmonids. *Comp Biochem Physiol* 73B, 125-141.
- Eliassen, R.A., Johnsen, H.K., Mayer, I., Jobling, M., 1998. Contrasts in osmoregulatory capacity of two Arctic charr, *Salvelinus alpinus* (L.), strains from northern Norway. *Aquaculture* 168, 255-269.
- Epstein, F.H., Silva, M., Kormanik, G.A., 1980. Role of Na-K-ATPase in chloride cell function. *Am J Physiol* 238, R246-R250.
- Ernst, S.A., Dodson, W.C., Karnaky, K.J., Jr., 1980. Structural diversity of occluding junctions in the low-resistance chloride-secreting opercular epithelium of seawater-adapted killifish (*Fundulus heteroclitus*). *J Cell Biol* 87, 488-497.
- Evans, D.H., 2008. Teleost fish osmoregulation: what have we learned since August Krogh, Homer Smith, and Ancel Keys. *Am J Physiol Regul Integr Comp Physiol* 295, R704-713. Epub 2008 Jun 2004.
- Evans, D.H., Mallery, C.H., 1975. Time course of sea water acclimation by euryhaline teleost, *Domitator maculatus*: correlation between potassium stimulation of sodium efflux and NaK activated ATPase activity. *J Comp Physiol* 96, 117-122.
- Evans, D.H., Mallery, C.H., Kravitz, L., 1973. Sodium extrusion by a fish acclimated to sea water: Physiological and biochemical description of a Na for K exchange system. *J Exp Biol* 58, 627-636.
- Evans, D.H., Piermarini, P.M., Choe, K.P., 2005. The multifunctional fish gill: dominant site of gas exchange, osmoregulation, acid-base regulation, and excretion of nitrogenous waste, *Physiol Rev*, United States, 97-177.
- Evans, D.H., Piermarini, P.M., Potts, W.T.W., 1999. Ionic transport in the fish gill epithelium. *J Exp Zool* 283, 641-652.
- Folmar, L.C., Dickhoff, W.W., 1980. The parr-smolt transformation (smoltification) and seawater adaptation in salmonids. A review of selected literature. *Aquaculture* 21, 1-37.
- Foot, C.J., Wood, C.C., Clarke, W.C., Blackburn, J., 1992. Circannual Cycle of Seawater Adaptability in *Oncorhynchus nerka*: Genetic Differences between Sympatric Sockeye Salmon and Kokanee. *Can J Fish Aquat Sci* 49, 99-109.
- Forrest, J.N., Jr., Cohen, A.D., Schon, D.A., Epstein, F.H., 1973. Na transport and Na-K-ATPase in gills during adaptation to seawater: effects of cortisol. *Am J Physiol* 224, 709-713.
- Foster, S.A., 1994. Inference of evolutionary pattern: diversionary displays of three-spine sticklebacks. *Behav Ecol* 5, 114-121.
- Gallis, J.L., Lasserre, P., Belloc, F., 1979. Freshwater adaptation in the euryhaline teleost, *Chelon labrosus*. I. Effects of adaptation, prolactin, cortisol and actinomycin D on plasma osmotic balance and (Na⁺-K⁺)ATPase in gill and kidney. *Gen Comp Endocrinol* 38, 1-10.

- Galvez, F., Reid, S.D., Hawkings, G., Goss, G.G., 2002. Isolation and characterization of mitochondria-rich cell types from the gill of freshwater rainbow trout. *Am J Physiol Regul Integr Comp Physiol* 282, R658-668.
- Gerking, S.H., Lee, R.M., 1980. Reproductive performance of the desert pupfish (*Cyprinodon n. nevadensis*) in relation to salinity. *Environ Biol Fishes* 5, 375-378.
- Gordon, M.S., 1959. Ionic Regulation in the Brown Trout (*Salmo trutta* L.). *J Exp Biol* 36, 227-252.
- Goss, G.G., Adamia, S., Galvez, F., 2001. Peanut lectin binds to a subpopulation of mitochondria-rich cells in the rainbow trout gill epithelium. *Am J Physiol Regul Integr Comp Physiol* 281, R1718-1725.
- Guderley, H.E., 1994. Physiological ecology and evolution of the threespine stickleback, in: M.A. Bell, S.A. Foster (Eds.), *The Evolutionary Biology of the Threespine Stickleback*. Oxford University, Oxford, 85-113.
- Gutz, M., 1970. Experimentelle Untersuchungen zur Salzadaptation verschiedener Rassen des Dreistchligen Stichlings (*Gasterosteus aculeatus* L.). *Internationale Revue der Gesamten Hydrobiologie* 55, 845-894.
- Guynn, S.R., Scofield, M.A., Petzel, D.H., 2002. Identification of mRNA and protein expression of the Na/K-ATPase α 1-, α 2- and α 3-subunit isoforms in Antarctic and New Zealand nototheniid fishes. *J Exp Marine Biol Ecol* 273, 15-32.
- Hagen, D.W., Gilbertson, L.G., 1972. Geographic Variation and Environmental Selection in *Gasterosteus aculeatus* L. in the Pacific Northwest, America. *Evolution* 26, 32-51.
- Handeland, S.O., Berge, Å., Björnsson, B.T., Stefansson, S.O., 1998. Effects of temperature and salinity on osmoregulation and growth of Atlantic salmon (*Salmo salar* L.) smolts in seawater. *Aquaculture* 168, 289-302.
- Hibbeler, S.S., Joern P.; Becker, Sven, 2008. Housekeeping genes for quantitative expression studies in the three-spined stickleback *Gasterosteus aculeatus*. *BMC Mol Biol*, 18.
- Hoar, W.S., 1976. Smolt Transformation: Evolution, Behavior, and Physiology. *J Fish Res Bd Can* 33, 1234-1252.
- Hu, Y.K., Kaplan, J.H., 2000. Site-directed chemical labeling of extracellular loops in a membrane protein. The topology of the Na,K-ATPase alpha-subunit. *J Biol Chem* 275, 19185-19191.
- Hwang, P.P., Lee, T.H., Lin, L.Y., 2011. Ion regulation in fish gills: recent progress in the cellular and molecular mechanisms. *Am J Physiol Regul Integr Comp Physiol* 301, R28-47.
- Ivanis, G., Esbaugh, A.J., Perry, S.F., 2008. Branchial expression and localization of SLC9A2 and SLC9A3 sodium/hydrogen exchangers and their possible role in acid-base regulation in freshwater rainbow trout (*Oncorhynchus mykiss*). *J Exp Biol* 211, 2467-2477.

- Jensen, M.K., Madsen, S.S., Kristiansen, K., 1998. Osmoregulation and salinity effects on the expression and activity of Na⁺,K⁺-ATPase in the gills of European sea bass, *Dicentrarchus labrax* (L.). *J Expl Zool* 282, 290-300.
- Jobling, M., 1995. Osmotic and ionic regulation, *Environ Biol Fishes*. Chapman and Hall, London, 211-249.
- Kaplan, J.H., 2002. Biochemistry of Na,K-ATPase. *Annu Rev Biochem* 71, 511-535.
- Karnaky, K.J., Kinter, L.B., Kinter, W.B., Stirling, C.E., 1976. Teleost chloride cell. II. Autoradiographic localization of gill Na,K-ATPase in killifish *Fundulus heteroclitus* adapted to low and high salinity environments. *J Cell Biol* 70, 157-177.
- Katsiadaki, I., Williams, T.D., Ball, J.S., Bean, T.P., Sanders, M.B., Wu, H., Santos, E.M., Brown, M.M., Baker, P., Ortega, F., Falciani, F., Craft, J.A., Tyler, C.R., Viant, M.R., Chipman, J.K., 2010. Hepatic transcriptomic and metabolomic responses in the Stickleback (*Gasterosteus aculeatus*) exposed to ethinyl-estradiol. *Aquat Toxicol* 97, 174-187. Epub 2009 Jul 2017.
- Kelly, S.P., Chow, I.N.K., Woo, N.Y.S., 1999. Haloplasticity of black seabream (*Mylio macrocephalus*): Hypersaline to freshwater acclimation. *J Exp Zool* 282, 226-241.
- Kersetter, T.H., Kirschner, L.B., Rafuse, D.D., 1970. On the mechanisms of sodium ion transport by the irrigated gills of rainbow trout (*Salmo gairdneri*). *J Gen Physiol* 56, 342-359.
- King, P.A., Goldstein, L., 1983. Organic osmolytes and cell volume regulation in fish. *Mol Physiol* 4, 53-66.
- Kingsley, D.M., Peichel, C.L., 2007. The Molecular Genetics of Evolutionary Change in Sticklebacks, in: P.L. Lutz (Ed.), *Biology of the Three-Spined Stickleback*. CRC Press, Boca Raton, 41-81.
- Knoch, H.J., Heuts, M.J., 1942. Influence de l'hormone thyroïdienne sur la régulation osmotique chez *Gasterosteus aculeatus* L. frome *gymnurus*. *Annales de la Société Royale Zoologique de Belgique* 73, 165-172.
- Krogh, A., 1938. The active absorption of ions in some freshwater animals. *J Comp Physiol A Sens Neural Behav Physiol* 25, 335-350.
- Kültz, D., Bastrop, R., Jürss, K., Siebers, D., 1992. Mitochondria-rich (MR) cells and the activities of the Na⁺K⁺-ATPase and carbonic anhydrase in the gill and opercular epithelium of *Oreochromis mossambicus* adapted to various salinities. *Comp Biochem Physiol B Comp Biochem* 102, 293-301.
- Lam, T.J., Hoar, W.S., 1967. Seasonal effects of prolactin on freshwater osmoregulation of the marine form (*trachurus*) of the stickleback *Gasterosteus aculeatus*. *Can J Zool* 45, 509-516.
- Lasserre, P., 1971. Increase of (Na⁺ plus K⁺)-dependent ATPase activity in gills and kidneys of two euryhaline marine teleosts, *Crenimugil labrosus* (Risso, 1826) and *Dicentrarchus labrax* (Linnaeus, 1758), during adaptation to fresh water. *Life Sci* 10, 113-119.
- Laurent, P., Dunel, S., 1980. Morphology of gill epithelia in fish. *Am J Physiol* 238, R147-159.

- Lee, T.H., Tsai, J.C., Fang, M.J., Yu, M.J., Hwang, P.P., 1998. Isoform expression of Na⁺-K⁺-ATPase alpha-subunit in gills of the teleost *Oreochromis mossambicus*. *Am J Physiol* 275, R926-932.
- Lin, Y.M., Chen, C.N., Lee, T.H., 2003. The expression of gill Na, K-ATPase in milkfish, *Chanos chanos*, acclimated to seawater, brackish water and fresh water. *Comp Biochem Physiol A Mol Integr Physiol* 135, 489-497.
- Lotan, R., 1973. Osmoregulation during Adaptation to Fresh Water in the Euryhaline Teleost *Aphanius dispar* Rüppell (Cyprinodontidae, pisces). *J Comp Physiol A Sens Neural Behav Physiol* 87, 339-349.
- Madsen, S., 1990a. Enhanced hypoosmoregulatory response to growth hormone after cortisol treatment in immature rainbow trout, *Salmo gairdneri*. *Fish Physiol Biochem* 8, 271-279.
- Madsen, S.S., 1990b. The role of cortisol and growth hormone in seawater adaptation and development of hypoosmoregulatory mechanisms in sea trout parr (*Salmo trutta trutta*). *Gen Comp Endocrinol* 79, 1-11.
- Madsen, S.S., Jensen, M.K., Nhr, J., Kristiansen, K., 1995. Expression of Na⁽⁺⁾-K⁽⁺⁾-ATPase in the brown trout, *Salmo trutta*: in vivo modulation by hormones and seawater. *Am J Physiol* 269, R1339-1345.
- Madsen, S.S., Larsen, B.K., Jensen, F.B., 1996. Effects of freshwater to seawater transfer on osmoregulation, acid-base balance and respiration in river migrating whitefish (*Coregonus lavaretus*). *J Comp Physiol B Biochem Syst Environ Physiol* 166, 101-109.
- Madsen, S.S., Naamansen, E.T., 1989. Plasma ionic regulation and gill Na⁺/K⁺-ATPase changes during rapid transfer to sea water of yearling rainbow trout, *Salmo gairdneri*: time course and seasonal variation. *J Fish Biol* 34, 829-840.
- Maetz, J., 1969. Sea water teleosts: Evidence for a sodium-potassium exchange in the branchial sodium-excreting pump. *Science* 166, 613-615.
- Marshall, W.S., 2002. Na⁽⁺⁾, Cl⁽⁻⁾, Ca⁽²⁺⁾ and Zn⁽²⁺⁾ transport by fish gills: retrospective review and prospective synthesis. *J Exp Zool* 293, 264-283.
- Matej, V.E., 1980. The ultrastructure of chloride cells of the gill epithelium in the stickleback, *Gasterosteus aculeatus* L. and crucian carp, *Carassius*. *Tsitologiya* 22, 1387-1391.
- Matej, V.E., Kharazova, A.D., Vinogradov, G.A., 1981. The response of *Gasterosteus aculeatus* L. gill epithelium chloride cells to changes of pH and salinity in the environment. *Tsitologiya* 23, 159-165.
- McCormick, S.D., Naiman, R.J., 1984. Osmoregulation in the brook trout, *Salvelinus fontinalis*-II. Effects of size, age and photoperiod on seawater survival and ionic regulation. *Comp Biochem Physiol A Comp Physiol* 79, 17-28.
- McCormick, S.D., Saunders, R.L., 1987. Preparatory Physiological Adaptations for Marine Life of Salmonids: Osmoregulation, Growth, and Metabolism. *Am Fish Soc Symp* 1, 211-229.

- Mobasheri, A., Avila, J., Cozar-Castellano, I., Brownleader, M.D., Trevan, M., Francis, M.J.O., Lamb, J.F., Martin-Vasallo, P., 2000. Na⁺, K⁺-ATPase isozyme diversity; comparative biochemistry and physiological implications of novel functional interactions. *Biosci Rep* 20, 51-91.
- Motais, R., Isaia, J., 1972. Evidence for an effect of ouabain on the branchial sodium-excreting pump of marine teleosts: Interaction between the inhibitor and external Na and K. *J Exp Biol* 57, 367-373.
- Moyes, C.D., Schulte, P.M., 2008. Ion and Water Balance, Principles of Animal Physiology, second ed. Pearson/Benjamin Cummings, Boston, 470-497.
- Münzing, J., 1963. The Evolution of Variation and Distributional Patterns in European Populations of the Three-Spined Stickleback, *Gasterosteus aculeatus*. *Evolution* 17, 320-332.
- Östlund-Nilsson, S., Mayer, I., Huntingford, F.A., 2007. Biology of the Three-Spined Stickleback, in: P.L. Lutz (Ed.), *Marine Biology*. CRC Press, Boca Raton.
- Palmgren, M.G., Nissen, P., 2011. P-type ATPases. *Annu Rev Biophys* 40, 243-266.
- Parks, S.K., Tresguerres, M., Goss, G.G., 2008. Theoretical considerations underlying Na⁽⁺⁾ uptake mechanisms in freshwater fishes. *Comp Biochem Physiol C Toxicol Pharmacol* 148, 411-418.
- Parry, G., 1958. Size and osmoregulation in salmonid fishes. *Nature* 181, 1218-1219.
- Parry, G., 1960a. The development of salinity tolerance in the salmon, *Salmo salar* (L.) and some related species. *J Exp Biol* 37, 425-434.
- Parry, G., 1960b. Osmotic and Ionic Changes in Blood and Muscle of Migrating Salmonids *J Exp Biol* 38, 411-427.
- Perry, S.F., 1997. The chloride cell: structure and function in the gills of freshwater fishes. *Annu Rev Physiol* 59, 325-347.
- Perry, S.F., Gilmour, K.M., 2006. Acid-base balance and CO₂ excretion in fish: Unanswered questions and emerging models. *Resp Physiol Neurobi* 154, 199-215.
- Perry, S.F., Shahsavarani, A., Georgalis, T., Bayaa, M., Furimsky, M., Thomas, S.L.Y., 2003. Channels, pumps, and exchangers in the gill and kidney of freshwater fishes: Their role in ionic and acid-base regulation. *J Exp Zool* 300A, 53-62.
- Philpott, C.W., 1980. Tubular system membranes of teleost chloride cells: osmotic response and transport sites. *Am J Physiol Regul Integr Comp Physiol* 238, R171-R184.
- Pisam, M., 1981. Membranous systems in the "chloride cell" of teleostean fish gill; their modifications in response to the salinity of the environment. *Anat Rec* 200, 401-414.
- Pisam, M., Caroff, A., Rambourg, A., 1987. Two types of chloride cells in the gill epithelium of a freshwater-adapted euryhaline fish: *Lebistes reticulatus*; their modifications during adaptation to saltwater. *Am J Anat* 179, 40-50.

- Pisam, M., Prunet, P., Boeuf, G., Rambourg, A., 1988. Ultrastructural features of chloride cells in the gill epithelium of the Atlantic salmon, *Salmo salar*, and their modifications during smoltification. *Am J Anat* 183, 235-244.
- Richards, J.G., Semple, J.W., Bystriansky, J.S., Schulte, P.M., 2003. Na⁺/K⁺-ATPase alpha-isoform switching in gills of rainbow trout (*Oncorhynchus mykiss*) during salinity transfer. *J Exp Biol* 206, 4475-4486.
- Sakamoto, T., Kozaka, T., Takahashi, A., Kawauchi, H., Ando, M., 2001. Medaka (*Oryzias latipes*) as a model for hypoosmoregulation of euryhaline fishes. *Aquaculture* 193, 347-354.
- Sardet, C., Pisam, M., Maetz, J., 1979. The surface epithelium of teleostean fish gills. Cellular and junctional adaptations of the chloride cell in relation to salt adaptation. *J Cell Biol* 80, 96-117.
- Schaarschmidt, T., Meyer, E., Juerss, K., 1999. A comparison of transport-related gill enzyme activities and tissue-specific free amino acid concentrations of Baltic Sea (brackish water) and freshwater threespine sticklebacks, *Gasterosteus aculeatus*, after salinity and temperature acclimation. *Mar Biol* 135, 689-697.
- Scott, G.R., Claiborne, J.B., Edwards, S.L., Schulte, P.M., Wood, C.M., 2005. Gene expression after freshwater transfer in gills and opercular epithelia of killifish: insight into divergent mechanisms of ion transport. *J Exp Biol* 208, 2719-2729.
- Scott, G.R., Richards, J.G., Forbush, B., Isenring, P., Schulte, P.M., 2004a. Changes in gene expression in gills of the euryhaline killifish *Fundulus heteroclitus* after abrupt salinity transfer. *Am J Physiol Cell Physiol*, C300-C309.
- Scott, G.R., Rogers, J.T., Richards, J.G., Wood, C.M., Schulte, P.M., 2004b. Intraspecific divergence of ionoregulatory physiology in the euryhaline teleost *Fundulus heteroclitus*: possible mechanisms of freshwater adaptation. *J Exp Biol* 207, 3399-3410.
- Seidelin, M., Madsen, S.S., Blenstrup, H., Tipsmark, C.K., 2000. Time-course changes in the expression of Na⁺, K⁺-ATPase in gills and pyloric caeca of brown trout (*Salmo trutta*) during acclimation to seawater. *Physiol Biochem Zool* 73, 446-453.
- Shrimpton, J.M., Patterson, D.A., Richards, J.G., Cooke, S.J., Schulte, P.M., Hinch, S.G., Farrell, A.P., 2005. Ionoregulatory changes in different populations of maturing sockeye salmon *Oncorhynchus nerka* during ocean and river migration. *J Exp Biol* 208, 4069-4078.
- Silva, P., Solomon, R., Spokes, K., Epstein, F., 1977. Ouabain inhibition of gill Na-K-ATPase: relationship to active chloride transport. *J Exp Zool* 199, 419-426.
- Singer, T.D., Clements, K.M., Semple, J.W., Schulte, P.M., Bystriansky, J.S., Finstad, B., Fleming, I.A., McKinley, R.S., 2002. Seawater tolerance and gene expression in two strains of Atlantic salmon smolts. *Can J Fish Aquatic Sci* 59.
- Stagg, R.M., Shuttleworth, T.J., 1982. Na⁺, K⁺ ATPase, ouabain binding and ouabain-sensitive oxygen consumption in gills from *Platichthys flesus* adapted to seawater and freshwater. *J Comp Physiol* 147, 93-99.

- Staurnes, M., Sigholt, T., Lysfjord, G., Gulseth, O.A., 1992. Difference in the Seawater Tolerance of Anadromous and Landlocked Populations of Arctic Char (*Salvelinus alpinus*). *Can J Fish Aquat Sci* 49, 443-447.
- Stuenkel, E.L., Hillyard, S.D., 1980. Effects of temperature and salinity on gill Na⁺-K⁺ ATPase activity in the pupfish, *Cyprinodon salinus*. *Comp Biochem Physiol* 67A, 179-182.
- Therien, A.G., Blostein, R., 2000. Mechanisms of sodium pump regulation. *Am J Physiol Cell Physiol* 279, C541-566.
- Tipsmark, C.K., Breves, J.P., Seale, A.P., Lerner, D.T., Hirano, T., Grau, E.G., 2011. Switching of Na⁺, K⁺-ATPase isoforms by salinity and prolactin in the gill of a cichlid fish. *J Endocrinol* 209, 237-244.
- Tipsmark, C.K., Luckenbach, J.A., Madsen, S.S., Kiilerich, P., Borski, R.J., 2008. Osmoregulation and expression of ion transport proteins and putative claudins in the gill of southern flounder (*Paralichthys lethostigma*). *Comp Biochem Physiol A Mol Integr Physiol* 150, 265-273. Epub 2008 Mar 2014.
- Tipsmark, C.K., Madsen, S.S., Borski, R.J., 2004. Effect of salinity on expression of branchial ion transporters in striped bass (*Morone saxatilis*). *J Exp Zool* 301A, 979-991.
- Tipsmark, C.K., Madsen, S.S., Seidelin, M., Christensen, A.S., Cutler, C.P., Cramb, G., 2002. Dynamics of Na⁺,K⁺,2Cl⁻ cotransporter and Na⁺,K⁺-ATPase expression in the branchial epithelium of brown trout (*Salmo trutta*) and Atlantic salmon (*Salmo salar*). *J Exp Zool* 293, 106-118.
- Utida, S., Kamiya, M., Shirai, N., 1971. Relationship Between the Activity of Na-K-Activated Adenosinetriphosphatase and the Number of Chloride Cells in Eel Gills with Special Reference to Sea-water Adaptation. *Comp Biochem Physiol* 38A, 443-447.
- Wagner, H.H., Conte, F.P., Fessler, J.L., 1969. Development of osmotic and ionic regulation in two races of chinook salmon *Oncorhynchus tshawytscha*. *Comp Biochem Physiol* 29, 325-341.
- Watanabe, W.O., Kuo, C.-M., Huang, M.-C., 1985. The ontogeny of salinity tolerance in the tilapias *Oreochromis aureus*, *O. niloticus*, and an *O. mossambicus* X *O. niloticus* hybrid, spawned and reared in freshwater. *Aquaculture* 47, 353-367.
- Wotton, R.J., 1984. *A Functional Biology of Sticklebacks*. University of California Press, Berkeley.
- Wright, S.H., 1991. The interface of animal and aqueous environment: strategies and constraints on the maintenance of solute balance, in: P.W. Hochachka, T.P. Mommsen (Eds.), *Biomedical and Molecular Biology of Fishes*. Elsevier, New York.

Appendix 1: Na⁺/K⁺-ATPase α Subunit Isoform Transcript Sequence Alignments

ATP1A1

```

ATP1A1-1      ACTCCGGGCTGAGAGAGAGAGAGAGAGAGAGAGAGAGAGGCGGAGTAGGAAAGTTGCAATTT 60
ATP1A1-3      -----
ATP1A1-2      -----
ATP1A1-4      -----

ATP1A1-1      AAAAAGACAATTGGATTGAGTGTCTCACACTTGCATTGCAACCATGGGGCTGGGAAGAG 120
ATP1A1-3      -----
ATP1A1-2      -----
ATP1A1-4      -----CTGCGTCTCCAGGAAG 16

ATP1A1-1      GGAAAGATGAGTACAAATTGGCACCAACCTCAGA---TGGAGGGAGGAAGAAATCGAAGA 177
ATP1A1-3      ----AGATGAGTACAAATTGGCACCAACCTCAGA---TGGAGGGAGGAAGAAATCGAAGA 53
ATP1A1-2      ----AGATGAGTACAAATTGGCACCAACCTCAGA---TGGAGGGAGGAAGAAATCGAAGA 53
ATP1A1-4      GACGCGAGCAGTATGAGCTGGCTGCGACCTCGGAGCACTGCAGCAAGAAGAAGGCGAAG 76
              **  ****  *   ****  *  *****  **      *  *  *  *****  *****

ATP1A1-1      AAGAAAAAGGGAAGAAGGATATGGAAGAACTGAAGAAAGAAGTTGACCTGGACGATCACA 237
ATP1A1-3      AAGAAAAAGGGAAGAAGGATATGGAAGAACTGAAGAAAGAAGTTGACCTGGACGATCACA 113
ATP1A1-2      AAGAAAAAGGGAAGAAGGATATGGAAGAACTGAAGAAAGAAGTTGACCTGGACGATCACA 113
ATP1A1-4      GGAAGAAGAAGGGAAGAAGGATATGGATGAACTCAAGAAAGAAGTGATATGGATGATCACA 136
              *  *  *  *  *****  *****  *****  *  *  *  *****  *****

ATP1A1-1      AGTTAACCTTGGACGAACTCCACAGAAAAGTATGGGACCGATCTAGTCTCTTTTAAGGGTC 297
ATP1A1-3      AGTTAACCTTGGACGAACTCCACAGAAAAGTATGGGACCGATCTAGCC-----AGGGGTC 167
ATP1A1-2      AGTTAACCTTGGACGAACTCCACAGAAAAGTATGGGACCGAT---GTCCTCTTTTAAGGGTC 170
ATP1A1-4      AACTGACCTCGACGAACTCAATCGCAAGTACGCAACAGACCTCAAC-----AATGGTT 190
              *  *  *  *  *****  *  *  *****  *  *  *  *  *  *  *  *  *  *

ATP1A1-1      TTTCCAACCTCCAGAGCAAAAAGAGATCCTGGCCAGAGACGGGCCAAACGCCCTCACACCTC 357
ATP1A1-3      TTTCCAACCTCCAGAGCAAAAAGAGATCCTGGCCAGAGACGGGCCAAACGCCCTCACACCTC 227
ATP1A1-2      TTTCCAACCTCCAGAGCAAAAAGAGATCCTGGCCAGAGACGGGCCAAACGCCCTCACACCTC 230
ATP1A1-4      TGACTTGGCCCAAGGCTGCTGAGATTCTGATCCGTGATGGGCCCAACGCCCTCACTCCTC 250
              *  *  *  *  *  *  *  *  *****  *  *  *  *  *  *  *  *  *  *  *  *  *

ATP1A1-1      CCCCCACAACGCCTGAATGGGTCAAGTTCGTAAACAGCTGTTTGGTGGTTTCTCCATGC 417
ATP1A1-3      CCCCCACAACGCCTGAATGGGTCAAGTTCGTAAACAGCTGTTTGGTGGTTTCTCCATGC 287
ATP1A1-2      CCCCCACAACGCCTGAATGGGTCAAGTTCGTAAACAGCTGTTTGGTGGTTTCTCCATGC 290
ATP1A1-4      CTCCACCACCCCGAGTGGGTCAAGTTCGTAAACAGATGTTTCGGCGGGTTCCTCCATGC 310
              *  *****  *  *  *  *  *****  *****  *****  *  *  *  *****  *****

ATP1A1-1      TGCTGTGGATTGGCGCCCTCCTCTGCTTCTGGCTTACGGTATCCAGGCGGCTCAGAAG 477
ATP1A1-3      TGCTGTGGATTGGCGCCCTCCTCTGCTTCTGGCTTACGGTATCCAGGCGGCTCAGAAG 347
ATP1A1-2      TGCTGTGGATTGGCGCCCTCCTCTGCTTCTGGCTTACGGTATCCAGGCGGCTCAGAAG 350
ATP1A1-4      TGCTGTGGACCGGCGCCGTCCTCTGTTTCTGGCTTACGGTATCCAGGCTGCAATGGAG 370
              *****  *****  *****  *****  *****  *****  *****  *  *  *

ATP1A1-1      ACGAACCGGCCAACGATAACTTGTACCTGGGCGTCGTGCTTTCTGCGGTCGTATCATCA 537
ATP1A1-3      ACGAACCGGCCAACGATAACTTGTACCTGGGCGTCGTGCTTTCTGCGGTCGTATCATCA 407
ATP1A1-2      ACGAACCGGCCAACGATAACTTGTACCTGGGCGTCGTGCTTTCTGCGGTCGTATCATCA 410
ATP1A1-4      ACGAGCCGGCTAATGACAACCTTGTACCTGGGCGTCGTACTTTCTGCTGTCGTATCATCA 430
              *****  *****  *  *  *****  *****  *****  *****  *****

```

ATP1A1-1 CCGGCTGCTTCTCCTACTACCAAGAGGCCAAGAGCTCCAAGATCATGGACTCCTTCAAGA 597
 ATP1A1-3 CCGGCTGCTTCTCCTACTACCAAGAGGCCAAGAGCTCCAAGATCATGGACTCCTTCAAGA 467
 ATP1A1-2 CCGGCTGCTTCTCCTACTACCAAGAGGCCAAGAGCTCCAAGATCATGGACTCCTTCAAGA 470
 ATP1A1-4 CCGGCTGCTTCTCCTACTACCAAGAGGCCAAGAGCTCCAAGATCATGGACTCCTTCAAGA 490

ATP1A1-1 ACCTGGTGCCACAGCAAGCTCTGGTTGTCCGTGACGGCGAGAAGAAGAGCATCAACGCTG 657
 ATP1A1-3 ACCTGGTGCCACAGCAAGCTCTGGTTGTCCGTGACGGCGAGAAGAAGAGCATCAACGCTG 527
 ATP1A1-2 ACCTGGTGCCACAGCAAGCTCTGGTTGTCCGTGACGGCGAGAAGAAGAGCATCAACGCTG 530
 ATP1A1-4 ACCTGGTCCCACAGCAAGCTCTGGTCGTCCGCGACGGCGAGAAGAAGAACATCAACGCTG 550

ATP1A1-1 AGGAGGTGGTGATTGGGGATTTGGTGGAGGTGAAAGGTGGAGACCGGATCCCTGCGGACC 717
 ATP1A1-3 AGGAGGTGGTGATTGGGGATTTGGTGGAGGTGAAAGGTGGAGACCGGATCCCTGCGGACC 587
 ATP1A1-2 AGGAGGTGGTGATTGGGGATTTGGTGGAGGTGAAAGGTGGAGACCGGATCCCTGCGGACC 590
 ATP1A1-4 AGGAGGTGGTGATTGGGGATTTGGTGGAGGTGAAAGGTGGAGACCGGATCCCGCTGATC 610
 ***** * ** *****

ATP1A1-1 TGCGGATTGTCTCTGCTAGTGGCTGCAAGGTGGACAACCTCCTCTCTGACTGGTGAATCAG 777
 ATP1A1-3 TGCGGATTGTCTCTGCTAGTGGCTGCAAGGTGGACAACCTCCTCTCTGACTGGTGAATCAG 647
 ATP1A1-2 TGCGGATTGTCTCTGCTAGTGGCTGCAAGGTGGACAACCTCCTCTCTGACTGGTGAATCAG 650
 ATP1A1-4 TGAGGATCATCTCTGCCACGGCTGCAAGGTGGACAACCTCCTCTCTGACCGCGAGTCCG 670
 ** **** *****

ATP1A1-1 AGCCTCAGACTCGTACTCCTGACTTCTCCAACGACAACCCGCTGGAGACCAGGAACATTG 837
 ATP1A1-3 AGCCTCAGACTCGTACTCCTGACTTCTCCAACGACAACCCGCTGGAGACCAGGAACATTG 707
 ATP1A1-2 AGCCTCAGACTCGTACTCCTGACTTCTCCAACGACAACCCGCTGGAGACCAGGAACATTG 710
 ATP1A1-4 AGCCTCAGACTCGTACTCCTGACTTCTCCAACGAGAACCCGCTGGAGACCAGGAACATTG 730

ATP1A1-1 CCTTCTTCTCCACCAACTGTGTTGAAGGTACCGCCAGAGGCGTCGTCATCAACACCGGAG 897
 ATP1A1-3 CCTTCTTCTCCACCAACTGTGTTGAAGGTACCGCCAGAGGCGTCGTCATCAACACCGGAG 767
 ATP1A1-2 CCTTCTTCTCCACCAACTGTGTTGAAGGTACCGCCAGAGGCGTCGTCATCAACACCGGAG 770
 ATP1A1-4 CCTTCTTCTCCACCAACTGTGTTGAAGGAACCGCCCGGCGTCGTCATCAGCACC GGCG 790
 ***** * *****

ATP1A1-1 ACCACACCGTCATGGGTCGCATCGCCACCCTGGCGTCCAGTCTGGATGGCGGCAAAACTC 957
 ATP1A1-3 ACCACACCGTCATGGGTCGCATCGCCACCCTGGCGTCCAGTCTGGATGGCGGCAAAACTC 827
 ATP1A1-2 ACCACACCGTCATGGGTCGCATCGCCACCCTGGCGTCCAGTCTGGATGGCGGCAAAACTC 830
 ATP1A1-4 ACCGTACCGTGATGGGTCGCATCGCCACGCTAGCCTCTGGCCTCGAAGTTGGACGCACCC 850
 *** *****

ATP1A1-1 CCATCGCCAAGGAGATCGAGCACTTCATCCACATCATCACAGGCGTGGCCGTCTTCCCTGG 1017
 ATP1A1-3 CCATCGCCAAGGAGATCGAGCACTTCATCCACATCATCACAGGCGTGGCCGTCTTCCCTGG 887
 ATP1A1-2 CCATCGCCAAGGAGATCGAGCACTTCATCCACATCATCACAGGCGTGGCCGTCTTCCCTGG 890
 ATP1A1-4 CCATCTCAATTGAGATCGAGCACTTCATCCACATCATCACAGGCGTGGCCGTCTTCCCTGG 910
 ***** *

ATP1A1-1 GTGTTTCCTTCTTCGTCCCTCGCTCATCCTCGGGTACGGCTGGCTGGAGGCCGTATCT 1077
 ATP1A1-3 GTGTTTCCTTCTTCGTCCCTCGCTCATCCTCGGGTACGGCTGGCTGGAGGCCGTATCT 947
 ATP1A1-2 GTGTTTCCTTCTTCGTCCCTCGCTCATCCTCGGGTACGGCTGGCTGGAGGCCGTATCT 950
 ATP1A1-4 GTGTTTCCTTCTTCGTCCCTCGCTCATCCTCGGGTACAGCTGGCTGGAGGCCGTATCT 970

ATP1A1-1 TCCTCATCGGCATCATCGTGGCCAACGTGCCAGAAGGTCTCCTGGCCACCGTCACCGTGT 1137
 ATP1A1-3 TCCTCATCGGCATCATCGTGGCCAACGTGCCAGAAGGTCTCCTGGCCACCGTCACCGTGT 1007
 ATP1A1-2 TCCTCATCGGCATCATCGTGGCCAACGTGCCAGAAGGTCTCCTGGCCACCGTCACCGTGT 1010
 ATP1A1-4 TCCTCATCGGCATCATCGTGGCCAACGTGCCAGAAGGTCTCCTGGCCACCGTCACCGTGT 1030

ATP1A1-1 GTCTGACCTGACCGCCAAGCGCATGGCCAAGAAGAAGCTGCCTGGTGAAGAAGCTTGAAG 1197
 ATP1A1-3 GTCTGACCTGACCGCCAAGCGCATGGCCAAGAAGAAGCTGCCTGGTGAAGAAGCTTGAAG 1067
 ATP1A1-2 GTCTGACCTGACCGCCAAGCGCATGGCCAAGAAGAAGCTGCCTGGTGAAGAAGCTTGAAG 1070
 ATP1A1-4 GTCTGACCTGACCGCCAAGCGCATGGCCAAGAAGAAGCTGCCTGGTGAAGAAGCTTGAAG 1090

ATP1A1-1 CTGTGGAGACCCTGGGCTCCACCTCCACCATCTGCTCCGACAAGACCGGCACCCTGACCC 1257
 ATP1A1-3 CTGTGGAGACCCTGGGCTCCACCTCCACCATCTGCTCCGACAAGACCGGCACCCTGACCC 1127
 ATP1A1-2 CTGTGGAGACCCTGGGCTCCACCTCCACCATCTGCTCCGACAAGACCGGCACCCTGACCC 1130
 ATP1A1-4 CTGTGGAGACCCTGGGCTCCACCTCCACCATCTGCTCCGACAAGACCGGCACCCTGACCC 1150

ATP1A1-1 AGAACAGGATGACCGTGGCCACATGTGGTTCGACAACCAGATCCACGAGGCCGACACCA 1317
 ATP1A1-3 AGAACAGGATGACCGTGGCCACATGTGGTTCGACAACCAGATCCACGAGGCCGACACCA 1187
 ATP1A1-2 AGAACAGGATGACCGTGGCCACATGTGGTTCGACAACCAGATCCACGAGGCCGACACCA 1190
 ATP1A1-4 AGAACAGGATGACCGTGGCCACATGTGGTTCGACAACCAGATCCACGAGGCCGACACCA 1210

ATP1A1-1 CGGAGAACCAGAGCGGCGCCTCCTTTGACAAGAGCTCTGCCACCTGGAACGCTCTGGCCC 1377
 ATP1A1-3 CGGAGAACCAGAGCGGCGCCTCCTTTGACAAGAGCTCTGCCACCTGGAACGCTCTGGCCC 1247
 ATP1A1-2 CGGAGAACCAGAGCGGCGCCTCCTTTGACAAGAGCTCTGCCACCTGGAACGCTCTGGCCC 1250
 ATP1A1-4 CGGAGAACCAGAGCGGCGCCTCCTTTGACAAGAGCTCTGCCACCTGGGCGGCCCTAGCCC 1270
 ***** * ***** ** ** *

ATP1A1-1 GAATTGCTGGGCTGTGTAACCGCGCCGTCTTCTAGCAGAACAGTCCAACGTTCCCATCC 1437
 ATP1A1-3 GAATTGCTGGGCTGTGTAACCGCGCCGTCTTCTAGCAGAACAGTCCAACGTTCCCATCC 1307
 ATP1A1-2 GAATTGCTGGGCTGTGTAACCGCGCCGTCTTCTAGCAGAACAGTCCAACGTTCCCATCC 1310
 ATP1A1-4 GAGTCGCCGGGCTGTGTAACCGCGCCGTCTTCTAGCAGAACAGTCCAACGTTCCCATCC 1330
 ** * * * ***** ***** * *****

ATP1A1-1 TGAAG-----AGAGACGTAGCCGGCGACGCCCTCAGAAG 1470
 ATP1A1-3 TGAAG-----AGAGACGTAGCCGGCGACGCCCTCAGAAG 1340
 ATP1A1-2 TGAAGTTTTGTCTTTGCTTCCAATCCACAGAGACGTAGCCGGCGACGCCCTCAGAAG 1370
 ATP1A1-4 TGAAG-----AGAGACGTGGCTGGGCGACGCCCTCAGAGT 1363
 ***** ***** ** *****

ATP1A1-1 CCGCCCTGCTCAAGTGTATTGAGCTGTGCTGTGGACCCGTCGGCAACATGAGAGACAAAT 1530
 ATP1A1-3 CCGCCCTGCTCAAGTGTATTGAGCTGTGCTGTGGACCCGTCGGCAACATGAGAGACAAAT 1400
 ATP1A1-2 CCGCCCTGCTCAAGTGTATTGAGCTGTGCTGTGGACCCGTCGGCAACATGAGAGACAAAT 1430
 ATP1A1-4 CGGCTCTGCTGAAATGTATCGAGCTGTGCTGTGGATCAGTGCAGGAGATGAGAAACAAA 1423
 * ** ***** ** ***** ***** * ** * *****

ATP1A1-1 ATGACAAGATTGCCGAAATCCCCTTCAACTCCACCAACAAATATCAGCTCTCCGTCCACA 1590
 ATP1A1-3 ATGACAAGATTGCCGAAATCCCCTTCAACTCCACCAACAAATATCAGCTCTCCGTCCACA 1460
 ATP1A1-2 ATGACAAGATTGCCGAAATCCCCTTCAACTCCACCAACAAATATCAGCTCTCCGTCCACA 1490
 ATP1A1-4 ACTCCAAAATTTAGAGATCCCCTTCAACTCCACCAACAAAGTACCAGCTTTCCATTCCATA 1483
 * *** ** * ** ***** ***** ** ***** ** * * *

ATP1A1-1 AGAACCAGACTCCGGGA---GAGACCAAGCTGCTGCTGGTGTATGAAAGGCGCCCCGAGA 1647
 ATP1A1-3 AGAACCAGACTCCGGGA---GAGACCAAGCTGCTGCTGGTGTATGAAAGGCGCCCCGAGA 1517
 ATP1A1-2 AGAACCAGACTCCGGGA---GAGACCAAGCTGCTGCTGGTGTATGAAAGGCGCCCCGAGA 1547
 ATP1A1-4 AGGATGGCACACCTGAAACGGGGTCCAACCACCTGCTGGTGTATGAAAGGCGCCCCGAGA 1543
 ** * ** *

ATP1A1-1 GGATTCTGGACCGCTGCTCCACCATCATGTTGCAAGGCAAAGAGCAGCCTCTGGACGACG 1707
 ATP1A1-3 GGATTCTGGACCGCTGCTCCACCATCATGTTGCAAGGCAAAGAGCAGCCTCTGGACGACG 1577
 ATP1A1-2 GGATTCTGGACCGCTGCTCCACCATCATGTTGCAAGGCAAAGAGCAGCCTCTGGACGACG 1607
 ATP1A1-4 GGATTCTGGACCGCTGCTCCACCATCATGTTGCAAGGCAAAGAGCAGCCTCTGGACGACG 1603
 ***** ***** ***** *****

ATP1A1-1 AGCTGAAAGACGCCTTCCAGAACGCCTACGTCGAGCTGGGAGGACTTGGAGAGAGAGTGC 1767
 ATP1A1-3 AGCTGAAAGACGCCTTCCAGAACGCCTACGTCGAGCTGGGAGGACTTGGAGAGAGAGTGC 1637
 ATP1A1-2 AGCTGAAAGACGCCTTCCAGAACGCCTACGTCGAGCTGGGAGGACTTGGAGAGAGAGTGC 1667
 ATP1A1-4 AGCTGAAAGACGCCTTCCAGAATGCCTACCTGGAAC TGGGGGTCTGGGAGAGCGAGTGC 1663

 ATP1A1-1 TGGGTTTCTGCCACTTCAACCTGCCTGATGACCAGTTC CAGAGGACTTTGCTTTTGACA 1827
 ATP1A1-3 TGGGTTTCTGCCACTTCAACCTGCCTGATGACCAGTTC CAGAGGACTTTGCTTTTGACA 1697
 ATP1A1-2 TGGGTTTCTGCCACTTCAACCTGCCTGATGACCAGTTC CAGAGGACTTTGCTTTTGACA 1727
 ATP1A1-4 TGGGTTTCTGCCACTTCAGCCTTCCCAGCAGCAGTTC CAGAGGCTTTGCTTTGACA 1723

 ATP1A1-1 CGGAGGAGGTGAACCTTCCCCTGAGAACCTTTGCTTCATCGGCCTCATGTCCATGATCG 1887
 ATP1A1-3 CGGAGGAGGTGAACCTTCCCCTGAGAACCTTTGCTTCATCGGCCTCATGTCCATGATCG 1757
 ATP1A1-2 CGGAGGAGGTGAACCTTCCCCTGAGAACCTTTGCTTCATCGGCCTCATGTCCATGATCG 1787
 ATP1A1-4 CGGAGGAGGTGAACCTTCCCCTGAGAACCTTTGCTTCATCGGCCTCATGTCCATGATCG 1783

 ATP1A1-1 ACCCTCCTCGTGCCGCCGTGCCGATGCCGTCGGCAAATGCAGAAGCGCCGAATCAAGG 1947
 ATP1A1-3 ACCCTCCTCGTGCCGCCGTGCCGATGCCGTCGGCAAATGCAGAAGCGCCGAATCAAGG 1817
 ATP1A1-2 ACCCTCCTCGTGCCGCCGTGCCGATGCCGTCGGCAAATGCAGAAGCGCCGAATCAAGG 1847
 ATP1A1-4 ACCCCCTCGTGCCGCCGTGCCGATGCCGTCGGCAAATGCAGGAGCGCCGAATCAAGG 1843

 ATP1A1-1 TTATCATGGTGACAGGAGACCACCGATCACTGCCAAAGCTATCGCCAAGGGAGTGGGTA 2007
 ATP1A1-3 TTATCATGGTGACAGGAGACCACCGATCACTGCCAAAGCTATCGCCAAGGGAGTGGGTA 1877
 ATP1A1-2 TTATCATGGTGACAGGAGACCACCGATCACTGCCAAAGCTATCGCCAAGGGAGTGGGTA 1907
 ATP1A1-4 TTATCATGGTAACGGGTGATCATCCAATCACAGCCAAGGCCATTGCTAAAGGTGTGGGCA 1903

 ATP1A1-1 TCATCTCTGAAGGCAACGAGACGGTTGAAGACATCGCCGCCCGCCTCAATGTACCAGTGT 2067
 ATP1A1-3 TCATCTCTGAAGGCAACGAGACGGTTGAAGACATCGCCGCCCGCCTCAATGTACCAGTGT 1937
 ATP1A1-2 TCATCTCTGAAGG-----AAA----- 1924
 ATP1A1-4 TCATCTCGAAGGCAACGAGACGGTTGAAGACATCGCCGCCCGTCTCAACATCCCAATCA 1963

 ATP1A1-1 CAGAGGTCAACCCAGGGATGCCAAGGCCTGTGTCTCCACGGTGGTGAGCTGAAGGAAA 2127
 ATP1A1-3 CAGAGGTCAACCCAGGGATGCCAAGGCCTGTGTCTCCACGGTGGTGAGCTGAAGGAAA 1997
 ATP1A1-2 -----AGGGATGCCAAGGCCTGTGTCTCCACGGTGGTGAGCTGAAGGAAA 1970
 ATP1A1-4 ACGAAGTCAACCCAGAGATGCCAAGGCCTGCGTCTCCACGGCGGGGACCTGAAAGATC 2023

 ATP1A1-1 TGACCGCCGAGCTGCTCGACAACGTGCTCCAGCACCACACTGAAATCGTCTTCGCCAGAA 2187
 ATP1A1-3 TGACCGCCGAGCTGCTCGACAACGTGCTCCAGCACCACACTGAAATCGTCTTCGCCAGAA 2057
 ATP1A1-2 TGACCGCCGAGCTGCTCGACAACGTGCTCCAGCACCACACTGAAATCGTCTTCGCCAGAA 2030
 ATP1A1-4 TGGCGCCTGAGCAGCTCGACGACATCCTCAAGTATCACACAGAGATTGTTTTCGCCAGAA 2083

 ATP1A1-1 CCTCCCCGAGCAGAAACTGATCATTGTGGAGGGCTGCCAGAGACAGGGAGCCATTGTGG 2247
 ATP1A1-3 CCTCCCCGAGCAGAAACTGATCATTGTGGAGGGCTGCCAGAGACAGGGAGCCATTGTGG 2117
 ATP1A1-2 CCTCCCCGAGCAGAAACTGATCATTGTGGAGGGCTGCCAGAGACAGGGAGCCATTGTGG 2090
 ATP1A1-4 CCTCCCCAGCAGAAAGCTGATCATCGTGAAGGCTGCCAGAGACAGGGAGCCATTGTGG 2143

 ATP1A1-1 CCGTGACGGGCGACGGCGTGAACGACTCTCCCGCTCTGAAGAAGGCCGACATCGGTGTCTG 2307
 ATP1A1-3 CCGTGACGGGCGACGGCGTGAACGACTCTCCCGCTCTGAAGAAGGCCGACATCGGTGTCTG 2177
 ATP1A1-2 CCGTGACGGGCGACGGCGTGAACGACTCTCCCGCTCTGAAGAAGGCCGACATCGGTGTCTG 2150
 ATP1A1-4 CCGTGACGGGCGACGGCGTGAACGACTCTCCCGCTCTGAAGAAGGCCGACATCGGTGTCTG 2203

ATP1A1-1 CTATGGGCATCGCCGGATCCGACGTCTCCAAGCAGGCCGCGACATGATCCTGCTGGACG 2367
 ATP1A1-3 CTATGGGCATCGCCGGATCCGACGTCTCCAAGCAGGCCGCGACATGATCCTGCTGGACG 2237
 ATP1A1-2 CTATGGGCATCGCCGGATCCGACGTCTCCAAGCAGGCCGCGACATGATCCTGCTGGACG 2210
 ATP1A1-4 CTATGGGCATCGCCGGATCCGACGTCTCCAAGCAGGCCGCGACATGATCCTGCTGGACG 2263

ATP1A1-1 ACAACTTTGCCTCCATCGTGACTGGGGTGAAGAAGGCCGTCTGATCCTTGACAACCTGA 2427
 ATP1A1-3 ACAACTTTGCCTCCATCGTGACTGGGGTGAAGAAGGCCGTCTGATCCTTGACAACCTGA 2297
 ATP1A1-2 ACAACTTTGCCTCCATCGTGACTGGGGTGAAGAAGGCCGTCTGATCCTTGACAACCTGA 2270
 ATP1A1-4 ACAACTTTGCCTCCATCGTGACTGGGGTGAAGAAGGCCGTCTGATCCTTGACAACCTGA 2323

ATP1A1-1 AGAAGTCCATCGCCTACACTCTAACCAGTAACATCCCCGAGATCTCCCCCTTCTCCTCT 2487
 ATP1A1-3 AGAAGTCCATCGCCTACACTCTAACCAGTAACATCCCCGAGATCTCCCCCTTCTCCTCT 2357
 ATP1A1-2 AGAAGTCCATCGCCTACACTCTAACCAGTAACATCCCCGAGATCTCCCCCTTCTCCTCT 2330
 ATP1A1-4 AGAAGTCCATCGCCTACACTCTGACCAGTAACATCCCCGAGATCACCCTTCTCCTCT 2383

ATP1A1-1 TCATCATCGCCAACATCCCCCTGCCCTGGGAACCGTCACCATCCTCTGCATTGACCTGG 2547
 ATP1A1-3 TCATCATCGCCAACATCCCCCTGCCCTGGGAACCGTCACCATCCTCTGCATTGACCTGG 2417
 ATP1A1-2 TCATCATCGCCAACATCCCCCTGCCCTGGGAACCGTCACCATCCTCTGCATTGACCTGG 2390
 ATP1A1-4 TCATCATCGCCAACATCCCCCTGCCCTGGGAACCGTCACCATCCTCTGCATTGACCTGG 2443

ATP1A1-1 GAACCGACATGGTCCCGCCATCTCCCTGGCTTATGAAGAAGCCGAGAGCGACATCATGA 2607
 ATP1A1-3 GAACCGACATGGTCCCGCCATCTCCCTGGCTTATGAAGAAGCCGAGAGCGACATCATGA 2477
 ATP1A1-2 GAACCGACATGGTCCCGCCATCTCCCTGGCTTATGAAGAAGCCGAGAGCGACATCATGA 2450
 ATP1A1-4 GAACAGACATGGTCCCGCCATCTCCCTGGCTTACGAAGCGGCCGAGAGCGACATCATGA 2503
 **** *****

ATP1A1-1 AGCGACAGCCAGAAACCCCAAACAGACAAGCTGGTGAACGAGAGGCTCATCAGCATCG 2667
 ATP1A1-3 AGCGACAGCCAGAAACCCCAAACAGACAAGCTGGTGAACGAGAGGCTCATCAGCATCG 2537
 ATP1A1-2 AGCGACAGCCAGAAACCCCAAACAGACAAGCTGGTGAACGAGAGGCTCATCAGCATCG 2510
 ATP1A1-4 AGCGACAGCCAGAAACCCCAAACAGACAAGCTGGTGAACGAGAGGCTCATCAGCATCG 2563

ATP1A1-1 CCTACGGACAGATCGGAATGATGCAGG--CCACAGC-CGGCTTCTTACATACTTTGTGA 2724
 ATP1A1-3 CCTACGGACAGATCGGAATGATGCAGG--CCACAGC-CGGCTTCTTACATACTTTGTGA 2594
 ATP1A1-2 CCTACGGACAGATCGGAATGATGCAGG--CCACAGC-CGGCTTCTTACATACTTTGTGA 2567
 ATP1A1-4 CCTACGGACAGATCGGGATGACAGAGGAGCTGTGTCTCTGGATTTTCCCCTCTTTGGTAA 2623

ATP1A1-1 TCCTGGCTGAAAACGGTTT-----CCTCCCAATGACCTGCTGGGGATCAGAGTGATGT 2778
 ATP1A1-3 TCCTGGCTGAAAACGGTTT-----CCTCCCAATGACCTGCTGGGGATCAGAGTGATGT 2648
 ATP1A1-2 TCCTGGCTGAAAACGGTTT-----CCTCCCAATGACCTGCTGGGGATCAGAGTGATGT 2621
 ATP1A1-4 TGAAGCCAGGAAAAGTTTGACCACCCCCCCCCCCCCCCCGGAAACC-----TTT 2676
 *

ATP1A1-1 GGGACGACAAAA-----TGG----TGAA----- 2797
 ATP1A1-3 GGGACGACAAAA-----TGG----TGAA----- 2667
 ATP1A1-2 GGGACGACAAAAACTTCTGTGCTGCTTCTCAGACCGTTGGAGGCTAAAAACCTCTTTTC 2681
 ATP1A1-4 AAAAGAACCAGC-----CGGG----TAAA----- 2696
 *

ATP1A1-1 -----
 ATP1A1-3 -----
 ATP1A1-2 AGGGATGTGACACACCGCGGCGTTTGTTTTCTGTGACGGCTCTTTGCTCCGAGAAGAAG 2741
 ATP1A1-4 -----

ATP1A1-1 -----CGACCT-GGAG----- 2807
ATP1A1-3 -----CGACCT-GGAG----- 2677
ATP1A1-2 GACGCGAGCAGTATGAGCTGGCTGCGACCTCGGAGCACTGCACCGAACCAGCTTGTTTTC 2801
ATP1A1-4 -----TTCT-GGATTTTCCCCAA----- 2715
 ** ***

ATP1A1-1 -----
ATP1A1-3 -----
ATP1A1-2 CAGCTTATCCCTCTCCCTTGAGTAAACACACACACACAGATCTCCCAGACCGTTTTTG 2861
ATP1A1-4 -----

ATP1A1-1 -----
ATP1A1-3 -----
ATP1A1-2 GAGCCCGGTCTCTGGTTTCCACCGCGTGGTATGGTACCAGGAATGCAATACACCTTTAA 2921
ATP1A1-4 -----

ATP1A1-1 -----
ATP1A1-3 -----
ATP1A1-2 AAAGGATTTGGATTAATTTGTCTCTCGATCACGTCCTCTCGAGGCAAGCATTGAAGAAT 2981
ATP1A1-4 -----

ATP1A1-1 -----
ATP1A1-3 -----
ATP1A1-2 CTGTCTTGACCGTGAGTCTTTGCAGGTTTCTGCCACTTCAGCCTTCCCAGCACCAGT 3041
ATP1A1-4 -----

ATP1A1-1 -----GACAGCT-----ACGGACAGCAGTGGA----- 2829
ATP1A1-3 -----GACAGCT-----ACGGACAGCAGTGGA----- 2699
ATP1A1-2 TCCCAGACGGCTTTGCTTTCGACACGGATGACAGAGGAGCTGTGTCTCTGGATTTTCCCC 3101
ATP1A1-4 -----GACAGCT-----ACGGGCAGCAGTGGA----- 2737
 *** *** **** *** ***

ATP1A1-1 -----CGTACGAGCGCAGAAAGATCGTAGAGTTCA 2859
ATP1A1-3 -----CGTACGAGCGCAGAAAGATCGTAGAGTTCA 2729
ATP1A1-2 TCTTTGTTGAAAAAAGGACCTTTCCTAAAACCTACGAGCAGAGGAAGATCGTGGAGTTCA 3161
ATP1A1-4 -----CCTACGAGCAGAGGAAGATCGTGGAGTTCA 2767
 * ***** ** ***** *****

ATP1A1-1 CATGCCACACAGCTTTCTTCGTCAGTATCGTGGTCGTCCAGTGGGCCGATCTGATCATCT 2919
ATP1A1-3 CATGCCACACAGCTTTCTTCGTCAGTATCGTGGTCGTCCAGTGGGCCGATCTGATCATCT 2789
ATP1A1-2 CCTGCCACACGGCCTTCTTCGCCAGCATCGTCGTCGTCCAGTGGGCCGACCTCATCATCT 3221
ATP1A1-4 CCTGCCACACGGCCTTCTTCGCCAGCATCGTCGTCGTCCAGTGGGCCGACCTCATCATCT 2827
* ***** ** ***** *** ***** *****

ATP1A1-1 GTAAGACCAGGAGGAACCTCCATCCTGCAACAGGGAATGAAGAACCGTATCCTCATCTTTG 2979
ATP1A1-3 GTAAGACCAGGAGGAACCTCCATCCTGCAACAGGGAATGAAGAACCGTATCCTCATCTTTG 2849
ATP1A1-2 GCAAGACCAGGAGGAACCTGTCTTCCAGCAGGGCATGAAGAACAAGATCCTGATCTTTG 3281
ATP1A1-4 GCAAGACCAGGAGGAACCTGTCTTCCAGCAGGGCATGAAGAACAAGATCCTGATCTTTG 2887
* ***** ***** ** * * ***** ***** *****

ATP1A1-1 GACTGTTTGAGGAGACCGCTCTGGCTGCTTTCCTGTCATACTGTCCGGGCATGGACATTG 3039
ATP1A1-3 GACTGTTTGAGGAGACCGCTCTGGCTGCTTTCCTGTCATACTGTCCGGGCATGGACATTG 2909
ATP1A1-2 GGCTGTTTGAGGAGACCGCCTGGCCGCCTTCTCTCTTACTGCCAGGCATGGACGTGG 3341
ATP1A1-4 GGCTGTTTGAGGAGACCGCCTGGCCGCCTTCTCTCTTACTGCCAGGCATGGACGTGG 2947
* ***** ***** ***** * ***** ** ***** ** ***** * *

ATP1A1-1 CCCTCAGAAATGTACCCCTCTCAAGCCATGCTGGTGGTTCTGTGCCTTCCCCTACTCCCTCC 3099
 ATP1A1-3 CCCTCAGAAATGTACCCCTCTCAAGCCATGCTGGTGGTTCTGTGCCTTCCCCTACTCCCTCC 2969
 ATP1A1-2 CCCTCAGAAATGTACCCCGTCAAGCCCAGCTGGTGGTTCTGCGCCTTCCCCTACTCCCTGC 3401
 ATP1A1-4 CCCTCAGAAATGTACCCGCTCAAGCCCAGCTGGTGGTTCTGCGCCTTCCCCTACTCCCTGC 3007

 ATP1A1-1 TCATCTTCCTGTATGATGAAGGCAGAAGATATATCCTCAGACGCAACCCAGGCGGTTGGG 3159
 ATP1A1-3 TCATCTTCCTGTATGATGAAGGCAGAAGATATATCCTCAGACGCAACCCAGGCGGTTGGG 3029
 ATP1A1-2 TCATCTTTATCTATGATGAAATCCGTAAGCTGATCCTCAGACGCAGCCCGGAGGTTGGG 3461
 ATP1A1-4 TCATCTTTATCTATGATGAAATCCGTAAGCTGATCCTCAGACGCAGCCCGGAGGTTGGG 3067
 ***** * ***** * * * ***** ** ** *****
 ATP1A1-1 TGGAGATGGAGACATACTACTGAGTCGACGCACAGTCAGTGTCCACCGTTGTTTTACTG 3219
 ATP1A1-3 TGGAGATGGAGACATACTACTGAGTCGACGCACAGTCAGTGTCCACCGTTGTTTTACTG 3089
 ATP1A1-2 TGGAGCGGGAGACCTACTATTA----- 3484
 ATP1A1-4 TGGAGCGGGAGACCTACTAT----- 3087
 ***** ***** *****
 ATP1A1-1 CCATGTTACATATTTGTCTAATACGTGAGTCAGACGCCAGAAACACAAAGCATGGACGAA 3279
 ATP1A1-3 CCATGTTACATATTTGTCTAATACGTGAGTCAGACGCCAGAAACACAAAGCATGGACGAA 3149
 ATP1A1-2 -----
 ATP1A1-4 -----
 ATP1A1-1 ATA----- 3282
 ATP1A1-3 ATAAGAATATTTGATGTATATGTAATTCACAATAAAACATTTCCGTACTATTGTACGAG 3209
 ATP1A1-2 -----
 ATP1A1-4 -----
 ATP1A1-1 ----
 ATP1A1-3 TTGT 3213
 ATP1A1-2 ----
 ATP1A1-4 ----

ATP1A3 (1 of 2)

ATP1A3 (1of2)-2 TGCAAGGCTGGAGGAGTACTGCGGCAACCCGCGGAAGGAGATCAAGTCGTGAAAACTAG 60
 ATP1A3 (1of2)-3 -CCGAGAGCAAAGGAAGGAAGCG-CATCCC-TGCGTGATGCTCCGCTCG----AGACC-G 52
 ATP1A3 (1of2)-4 -----
 ATP1A3 (1of2)-1 -----
 ATP1A3 (1of2)-2 CAGCGCTGCCCC-----GTCGCTTCGCCGGTCTTTCTGCGCAAGTATCCGAGAGCAAA-- 113
 ATP1A3 (1of2)-3 CAGCATTTTCAATTTGAAAGACGTCTCACTGG-----AGGGGAAAAGATTGAAGGCTAAACC 107
 ATP1A3 (1of2)-4 -----
 ATP1A3 (1of2)-1 -----
 ATP1A3 (1of2)-2 GGAAGG-----AAGCGCATC--CCTGCG---TGATGCTCCGCTCGAGACCGCAGCATTTTC 163
 ATP1A3 (1of2)-3 GGAAGGTTTGAAGACCGTTAATTTAAGCCCTCCTCCTCCCCCAAAAAG-AACATTTG 166
 ATP1A3 (1of2)-4 -----
 ATP1A3 (1of2)-1 -----
 ATP1A3 (1of2)-2 ATTTGA-----AAGACGTCTCACT-----GGAGGGGAAAAGATTG 198
 ATP1A3 (1of2)-3 GTTAAATCTGTAGTTAACTGCCATGACGTCTTTTTTTAATTTAGGAGAAAAAAACTG 226
 ATP1A3 (1of2)-4 -----
 ATP1A3 (1of2)-1 -----CT-----GCGGCAAAGAGATTT 17

ATP1A3 (1of2)-2 AAGG-----CTAAACCGG-----AAGGCATTTTGCTATAAATCAACGCGAGGGGCTGA 246
ATP1A3 (1of2)-3 AGCATATTCTCTTTATTTTTTTTTTCAAGGCATTTTGCTATAAATCAACGCGAGGGGCTGA 286
ATP1A3 (1of2)-4 -----ATGTTACTGTAT-----GGCCG- 17
ATP1A3 (1of2)-1 G-----CT-----CAC-CTGCT-----CTG- 31
* * ** * *

ATP1A3 (1of2)-2 CACCTCTCAAGCTGTGCATCACCTGAGAGGAGAAGAGTGACTGCGCCAACATGGGGGACA 306
ATP1A3 (1of2)-3 CACCTCTCAAGCTGTGCATCACCTGAGAGGAGAAGAGTGACTGCGCCAACATGGGGGACA 346
ATP1A3 (1of2)-4 -----TTCAGACAGT-TACCGCGT-----TGCCACCACACAGGACA 52
ATP1A3 (1of2)-1 -----TCAA-CAGT-TACCGCGT-----TGCCACCACACAGGACA 64
*** * ** * * * * **** * * *****

ATP1A3 (1of2)-2 AAGATGACCGCTCCCCAAGAAGAAGAAGGGGGCCAAGGACATGGATGACCTGAAGAAAAG 366
ATP1A3 (1of2)-3 AAGATGACCGCTCCCCAAGAAGAAGAAGGGGGCCAAGGACATGGATGACCTGAAGAAAAG 406
ATP1A3 (1of2)-4 AAGATGACCGCTCCCCAAGAAGAAGAAGGGGGCCAAGGACATGGATGACCTGAAGAAAAG 112
ATP1A3 (1of2)-1 AAGATGACCGCTCCCCAAGAAGAAGAAGGGGGCCAAGGACATGGATGACCTGAAGAAAAG 124

ATP1A3 (1of2)-2 AAGTGCCCATACGGAACATAAGATGTCCATAGAAGAAGTATGCAGGAAATACCAGACAG 426
ATP1A3 (1of2)-3 AAGTGCCCATACGGAACATAAGATGTCCATAGAAGAAGTATGCAGGAAATACCAGACAG 466
ATP1A3 (1of2)-4 AAGTGCCCATACGGAACATAAGATGTCCATAGAAGAAGTATGCAGGAAATACCAGACAG 172
ATP1A3 (1of2)-1 AAGTGCCCATACGGAACATAAGATGTCCATAGAAGAAGTATGCAGGAAATACCAGACAG 184

ATP1A3 (1of2)-2 ACATTGTTTCAGGGGTTGACCAATGCCAAGGCAGCAGAGTATCTGATCAGGGATGGTCCCA 486
ATP1A3 (1of2)-3 ACATTGTTTCAGGGGTTGACCAATGCCAAGGCAGCAGAGTATCTGATCAGGGATGGTCCCA 526
ATP1A3 (1of2)-4 ACATTGTTTCAGGGGTTGACCAATGCCAAGGCAGCAGAGTATCTGATCAGGGATGGTCCCA 232
ATP1A3 (1of2)-1 ACATTGTTTCAGGGGTTGACCAATGCCAAGGCAGCAGAGTATCTGATCAGGGATGGTCCCA 244

ATP1A3 (1of2)-2 ATGCTCTCACCCCTCCTCCTACGACCCCGAGTGGGTCAAGTTCGTGCGCCAGCTGTTTG 546
ATP1A3 (1of2)-3 ATGCTCTCACCCCTCCTCCTACGACCCCGAGTGGGTCAAGTTCGTGCGCCAGCTGTTTG 586
ATP1A3 (1of2)-4 ATGCTCTCACCCCTCCTCCTACGACCCCGAGTGGGTCAAGTTCGTGCGCCAGCTGTTTG 292
ATP1A3 (1of2)-1 ATGCTCTCACCCCTCCTCCTACGACCCCGAGTGGGTCAAGTTCGTGCGCCAGCTGTTTG 304

ATP1A3 (1of2)-2 GTGGATTCTCCGTCTGCTGTGGACCGGCGCCATCCTCTGTTTCTGGCGTACGCCATCC 606
ATP1A3 (1of2)-3 GTGGATTCTCCGTCTGCTGTGGACCGGCGCCATCCTCTGTTTCTGGCGTACGCCATCC 646
ATP1A3 (1of2)-4 GTGGATTCTCCGTCTGCTGTGGACCGGCGCCATCCTCTGTTTCTGGCGTACGCCATCC 352
ATP1A3 (1of2)-1 GTGGATTCTCCGTCTGCTGTGGACCGGCGCCATCCTCTGTTTCTGGCGTACGCCATCC 364

ATP1A3 (1of2)-2 AGGCAGCCACTGAGGACGATCCTGCAGGAGACAATTTGTACTTAGGTATTGTGCTCACAG 666
ATP1A3 (1of2)-3 AGGCAGCCACTGAGGACGATCCTGCAGGAGACAATTTGTACTTAGGTATTGTGCTCACAG 706
ATP1A3 (1of2)-4 AGGCAGCCACTGAGGACGATCCTGCAGGAGACAATTTGTACTTAGGTATTGTGCTCACAG 412
ATP1A3 (1of2)-1 AGGCAGCCACTGAGGACGATCCTGCAGGAGACAATTTGTACTTAGGTATTGTGCTCACAG 424

ATP1A3 (1of2)-2 CTGTCGTGGTCATCACTGGATGCTTCTCATACTTTCAAGAGGCCAAGAGCTCCAAAATCA 726
ATP1A3 (1of2)-3 CTGTCGTGGTCATCACTGGATGCTTCTCATACTTTCAAGAGGCCAAGAGCTCCAAAATCA 766
ATP1A3 (1of2)-4 CTGTCGTGGTCATCACTGGATGCTTCTCATACTTTCAAGAGGCCAAGAGCTCCAAAATCA 472
ATP1A3 (1of2)-1 CTGTCGTGGTCATCACTGGATGCTTCTCATACTTTCAAGAGGCCAAGAGCTCCAAAATCA 484

ATP1A3 (1of2)-2 TGGAGTCCTTCAAAAACATGGTGCCTCAGCAAGCGCTGGTGATCCGTGAGGGTGAAAAGG 786
ATP1A3 (1of2)-3 TGGAGTCCTTCAAAAACATGGTGCCTCAGCAAGCGCTGGTGATCCGTGAGGGTGAAAAGG 826
ATP1A3 (1of2)-4 TGGAGTCCTTCAAAAACATGGTGCCTCAGCAAGCGCTGGTGATCCGTGAGGGTGAAAAGG 532
ATP1A3 (1of2)-1 TGGAGTCCTTCAAAAACATGGTGCCTCAGCAAGCGCTGGTGATCCGTGAGGGTGAAAAGG 544

ATP1A3 (1of2)-2 TGCAGATCAATGCTGAAGAAGTAGTGGGTGGAGATCTGGTTGAAGTGAAGGGAGGAGACC 846
 ATP1A3 (1of2)-3 TGCAGATCAATGCTGAAGAAGTAGTGGGTGGAGATCTGGTTGAAGTGAAGGGAGGAGACC 886
 ATP1A3 (1of2)-4 TGCAGATCAATGCTGAAGAAGTAGTGGGTGGAGATCTGGTTGAAGTGAAGGGAGGAGACC 592
 ATP1A3 (1of2)-1 TGCAGATCAATGCTGAAGAAGTAGTGGGTGGAGATCTGGTTGAAGTGAAGGGAGGAGACC 604

ATP1A3 (1of2)-2 GGATCCCTGCTGATATCAGGGTGGTTTCCGCTCATGGCTGCAAGGTCGATAACTCCTCCC 906
 ATP1A3 (1of2)-3 GGATCCCTGCTGATATCAGGGTGGTTTCCGCTCATGGCTGCAAGGTCGATAACTCCTCCC 946
 ATP1A3 (1of2)-4 GGATCCCTGCTGATATCAGGGTGGTTTCCGCTCATGGCTGCAAGGTCGATAACTCCTCCC 652
 ATP1A3 (1of2)-1 GGATCCCTGCTGATATCAGGGTGGTTTCCGCTCATGGCTGCAAGGTCGATAACTCCTCCC 664

ATP1A3 (1of2)-2 TCACAGGCGAGTCCGAACCTCAGAGCAGGTCACCCGACTGTACCCATGACAACCCCTTAG 966
 ATP1A3 (1of2)-3 TCACAGGCGAGTCCGAACCTCAGAGCAGGTCACCCGACTGTACCCATGACAACCCCTTAG 1006
 ATP1A3 (1of2)-4 TCACAGGCGAGTCCGAACCTCAGAGCAGGTCACCCGACTGTACCCATGACAACCCCTTAG 712
 ATP1A3 (1of2)-1 TCACAGGCGAGTCCGAACCTCAGAGCAGGTCACCCGACTGTACCCATGACAACCCCTTAG 724

ATP1A3 (1of2)-2 AAACCCGAAACATTGCTTTCTTCTCCACCAACTGTGTTGAAGGCACAGCGCGCGCATTG 1026
 ATP1A3 (1of2)-3 AAACCCGAAACATTGCTTTCTTCTCCACCAACTGTGTTGAAGGCACAGCGCGCGCATTG 1066
 ATP1A3 (1of2)-4 AAACCCGAAACATTGCTTTCTTCTCCACCAACTGTGTTGAAGGCACAGCGCGCGCATTG 772
 ATP1A3 (1of2)-1 AAACCCGAAACATTGCTTTCTTCTCCACCAACTGTGTTGAAGGCACAGCGCGCGCATTG 784

ATP1A3 (1of2)-2 TTATCTGCACCGGTGACAACACAGTGATGGGTGCGCATCGCCACTCTGACATCTGGCCTGG 1086
 ATP1A3 (1of2)-3 TTATCTGCACCGGTGACAACACAGTGATGGGTGCGCATCGCCACTCTGACATCTGGCCTGG 1126
 ATP1A3 (1of2)-4 TTATCTGCACCGGTGACAACACAGTGATGGGTGCGCATCGCCACTCTGACATCTGGCCTGG 832
 ATP1A3 (1of2)-1 TTATCTGCACCGGTGACAACACAGTGATGGGTGCGCATCGCCACTCTGACATCTGGCCTGG 844

ATP1A3 (1of2)-2 AGACCGGAAAAACCCCATCGCAAAGGAGATCGAGCACTTCATCCACATCATCACAGGTG 1146
 ATP1A3 (1of2)-3 AGACCGGAAAAACCCCATCGCAAAGGAGATCGAGCACTTCATCCACATCATCACAGGTG 1186
 ATP1A3 (1of2)-4 AGACCGGAAAAACCCCATCGCAAAGGAGATCGAGCACTTCATCCACATCATCACAGGTG 892
 ATP1A3 (1of2)-1 AGACCGGAAAAACCCCATCGCAAAGGAGATCGAGCACTTCATCCACATCATCACAGGTG 904

ATP1A3 (1of2)-2 TGGCCGTCTTTCTGGGACTCACCTTTTTTCATCCTGGCCATCGTCTGGGTTACTCCTGGC 1206
 ATP1A3 (1of2)-3 TGGCCGTCTTTCTGGGACTCACCTTTTTTCATCCTGGCCATCGTCTGGGTTACTCCTGGC 1246
 ATP1A3 (1of2)-4 TGGCCGTCTTTCTGGGACTCACCTTTTTTCATCCTGGCCATCGTCTGGGTTACTCCTGGC 952
 ATP1A3 (1of2)-1 TGGCCGTCTTTCTGGGACTCACCTTTTTTCATCCTGGCCATCGTCTGGGTTACTCCTGGC 964

ATP1A3 (1of2)-2 TGGAGGCTGTCATCTTCCTCATCGGCATCATCGTGGCTAACGTGCCTGAAGGGCTGCTGG 1266
 ATP1A3 (1of2)-3 TGGAGGCTGTCATCTTCCTCATCGGCATCATCGTGGCTAACGTGCCTGAAGGGCTGCTGG 1306
 ATP1A3 (1of2)-4 TGGAGGCTGTCATCTTCCTCATCGGCATCATCGTGGCTAACGTGCCTGAAGGGCTGCTGG 1012
 ATP1A3 (1of2)-1 TGGAGGCTGTCATCTTCCTCATCGGCATCATCGTGGCTAACGTGCCTGAAGGGCTGCTGG 1024

ATP1A3 (1of2)-2 CCACAGTCACTGTGTGTCTGACCTTAACTGCCAAGCGTATGGCTAAGAAGAACTGCCTTG 1326
 ATP1A3 (1of2)-3 CCACAGTCACTGTGTGTCTGACCTTAACTGCCAAGCGTATGGCTAAGAAGAACTGCCTTG 1366
 ATP1A3 (1of2)-4 CCACAGTCACTGTGTGTCTGACCTTAACTGCCAAGCGTATGGCTAAGAAGAACTGCCTTG 1072
 ATP1A3 (1of2)-1 CCACAGTCACTGTGTGTCTGACCTTAACTGCCAAGCGTATGGCTAAGAAGAACTGCCTTG 1084

ATP1A3 (1of2)-2 TTAAGAACTTGAAGCTGTGGAACCCTGGGCTCCACCTCCACCATCTGCTCTGACAAAA 1386
 ATP1A3 (1of2)-3 TTAAGAACTTGAAGCTGTGGAACCCTGGGCTCCACCTCCACCATCTGCTCTGACAAAA 1426
 ATP1A3 (1of2)-4 TTAAGAACTTGAAGCTGTGGAACCCTGGGCTCCACCTCCACCATCTGCTCTGACAAAA 1132
 ATP1A3 (1of2)-1 TTAAGAACTTGAAGCTGTGGAACCCTGGGCTCCACCTCCACCATCTGCTCTGACAAAA 1144

ATP1A3 (1of2)-2 CAGGCACCTTGACCCAGAACAGGATGACCGTGGCGCACATGTGGTTTGACAACCAGATCC 1446
ATP1A3 (1of2)-3 CAGGCACCTTGACCCAGAACAGGATGACCGTGGCGCACATGTGGTTTGACAACCAGATCC 1486
ATP1A3 (1of2)-4 CAGGCACCTTGACCCAGAACAGGATGACCGTGGCGCACATGTGGTTTGACAACCAGATCC 1192
ATP1A3 (1of2)-1 CAGGCACCTTGACCCAGAACAGGATGACCGTGGCGCACATGTGGTTTGACAACCAGATCC 1204

ATP1A3 (1of2)-2 ACGAGGCCGACACCACTGAGGACCAGTCTGGTGCCTCTTTTGACAAGAGCTCCATAACGT 1506
ATP1A3 (1of2)-3 ACGAGGCCGACACCACTGAGGACCAGTCTGGTGCCTCTTTTGACAAGAGCTCCATAACGT 1546
ATP1A3 (1of2)-4 ACGAGGCCGACACCACTGAGGACCAGTCTGGTGCCTCTTTTGACAAGAGCTCCATAACGT 1252
ATP1A3 (1of2)-1 ACGAGGCCGACACCACTGAGGACCAGTCTGGTGCCTCTTTTGACAAGAGCTCCATAACGT 1264

ATP1A3 (1of2)-2 GGATTAGCCTGGCCCGCGTCGCTGCCCTGTGCAACCGCGCTCAGTTTAAAGCGGGACAAG 1566
ATP1A3 (1of2)-3 GGATTAGCCTGGCCCGCGTCGCTGCCCTGTGCAACCGCGCTCAGTTTAAAGCGGGACAAG 1606
ATP1A3 (1of2)-4 GGATTAGCCTGGCCCGCGTCGCTGCCCTGTGCAACCGCGCTCAGTTTAAAGCGGGACAAG 1312
ATP1A3 (1of2)-1 GGATTAGCCTGGCCCGCGTCGCTGCCCTGTGCAACCGCGCTCAGTTTAAAGCGGGACAAG 1324

ATP1A3 (1of2)-2 ACCAGCTGCCCATCTTGAAGCGGGACGTGGCCGGTGATGCCTCAGAGTCAGCCCTGCTGA 1626
ATP1A3 (1of2)-3 ACCAGCTGCCCATCTTGAAGCGGGACGTGGCCGGTGATGCCTCAGAGTCAGCCCTGCTGA 1666
ATP1A3 (1of2)-4 ACCAGCTGCCCATCTTGAAGCGGGACGTGGCCGGTGATGCCTCAGAGTCAGCCCTGCTGA 1372
ATP1A3 (1of2)-1 ACCAGCTGCCCATCTTGAAGCGGGACGTGGCCGGTGATGCCTCAGAGTCAGCCCTGCTGA 1384

ATP1A3 (1of2)-2 AGTGTATCGAGCTGTCTGTGGCTCCGTGAGGGCAATGAGGGACAGGAACAAGAAGGTAG 1686
ATP1A3 (1of2)-3 AGTGTATCGAGCTGTCTGTGGCTCCGTGAGGGCAATGAGGGACAGGAACAAGAAGGTAG 1726
ATP1A3 (1of2)-4 AGTGTATCGAGCTGTCTGTGGCTCCGTGAGGGCAATGAGGGACAGGAACAAGAAGGTAG 1432
ATP1A3 (1of2)-1 AGTGTATCGAGCTGTCTGTGGCTCCGTGAGGGCAATGAGGGACAGGAACAAGAAGGTAG 1444

ATP1A3 (1of2)-2 CCGAGATCCCCTTCAACTCCACCAACAAATACCAGCTCTCAGTGCACGAGACAGAGGACC 1746
ATP1A3 (1of2)-3 CCGAGATCCCCTTCAACTCCACCAACAAATACCAGCTCTCAGTGCACGAGACAGAGGACC 1786
ATP1A3 (1of2)-4 CCGAGATCCCCTTCAACTCCACCAACAAATACCAGCTCTCAGTGCACGAGACAGAGGACC 1492
ATP1A3 (1of2)-1 CCGAGATCCCCTTCAACTCCACCAACAAATACCAGCTCTCAGTGCACGAGACAGAGGACC 1504

ATP1A3 (1of2)-2 TCAATGACAACCGCTACCTGCTCGTGATGAAGGGAGCCCCTGAGAGGGTCCTGGAATGTT 1806
ATP1A3 (1of2)-3 TCAATGACAACCGCTACCTGCTCGTGATGAAGGGAGCCCCTGAGAGGGTCCTGGAATGTT 1846
ATP1A3 (1of2)-4 TCAATGACAACCGCTACCTGCTCGTGATGAAGGGAGCCCCTGAGAGGGTCCTGGAATGTT 1552
ATP1A3 (1of2)-1 TCAATGACAACCGCTACCTGCTCGTGATGAAGGGAGCCCCTGAGAGGGTCCTGGAATGTT 1564

ATP1A3 (1of2)-2 GCTCCACCATCCTGGTGCAGGGGAAGGAGCAACCTCTGGATGAGGAATTAAGGAAGCTT 1866
ATP1A3 (1of2)-3 GCTCCACCATCCTGGTGCAGGGGAAGGAGCAACCTCTGGATGAGGAATTAAGGAAGCTT 1906
ATP1A3 (1of2)-4 GCTCCACCATCCTGGTGCAGGGGAAGGAGCAACCTCTGGATGAGGAATTAAGGAAGCTT 1612
ATP1A3 (1of2)-1 GCTCCACCATCCTGGTGCAGGGGAAGGAGCAACCTCTGGATGAGGAATTAAGGAAGCTT 1624

ATP1A3 (1of2)-2 TCCAGAACGCATACATGGAGCTGGGAGGTCTCGGAGAGAGAGTGCTGGGTTTCTGCCACG 1926
ATP1A3 (1of2)-3 TCCAGAACGCATACATGGAGCTGGGAGGTCTCGGAGAGAGAGTGCTGGGTTTCTGCCACG 1966
ATP1A3 (1of2)-4 TCCAGAACGCATACATGGAGCTGGGAGGTCTCGGAGAGAGAGTGCTGGGTTTCTGCCACG 1672
ATP1A3 (1of2)-1 TCCAGAACGCATACATGGAGCTGGGAGGTCTCGGAGAGAGAGTGCTGGGTTTCTGCCACG 1684

ATP1A3 (1of2)-2 TGTTGCTGCCCGAAGACCAATACCCCAAGGGTTTTGCCTTTGACACGGATGATGTCAACT 1986
ATP1A3 (1of2)-3 TGTTGCTGCCCGAAGACCAATACCCCAAGGGTTTTGCCTTTGACACGGATGATGTCAACT 2026
ATP1A3 (1of2)-4 TGTTGCTGCCCGAAGACCAATACCCCAAGGGTTTTGCCTTTGACACGGATGATGTCAACT 1732
ATP1A3 (1of2)-1 TGTTGCTGCCCGAAGACCAATACCCCAAGGGTTTTGCCTTTGACACGGATGATGTCAACT 1744

ATP1A3 (1of2)-2 TCCAGACAAAAGACCTTTGCTTCGTTGGCCTCATGTCCATGATCGACCCTCCTCGTGCTG 2046
 ATP1A3 (1of2)-3 TCCAGACAAAAGACCTTTGCTTCGTTGGCCTCATGTCCATGATCGACCCTCCTCGTGCTG 2086
 ATP1A3 (1of2)-4 TCCAGACAAAAGACCTTTGCTTCGTTGGCCTCATGTCCATGATCGACCCTCCTCGTGCTG 1792
 ATP1A3 (1of2)-1 TCCAGACAAAAGACCTTTGCTTCGTTGGCCTCATGTCCATGATCGACCCTCCTCGTGCTG 1804

ATP1A3 (1of2)-2 CCGTGCCTGATGCTGTTGGCAAATGCCGATCCGCTGGTATCAAGGTCATTATGGTCACTG 2106
 ATP1A3 (1of2)-3 CCGTGCCTGATGCTGTTGGCAAATGCCGATCCGCTGGTATCAAGGTCATTATGGTCACTG 2146
 ATP1A3 (1of2)-4 CCGTGCCTGATGCTGTTGGCAAATGCCGATCCGCTGGTATCAAGGTCATTATGGTCACTG 1852
 ATP1A3 (1of2)-1 CCGTGCCTGATGCTGTTGGCAAATGCCGATCCGCTGGTATCAAGGTCATTATGGTCACTG 1864

ATP1A3 (1of2)-2 GCGATCACCCAATCACAGCCAAGGCAATTGCCAAGGGAGTGGGCATCATCTCAGAGGGCA 2166
 ATP1A3 (1of2)-3 GCGATCACCCAATCACAGCCAAGGCAATTGCCAAGGGAGTGGGCATCATCTCAGAGGGCA 2206
 ATP1A3 (1of2)-4 GCGATCACCCAATCACAGCCAAGGCAATTGCCAAGGGAGTGGGCATCATCTCAGAGGGCA 1912
 ATP1A3 (1of2)-1 GCGATCACCCAATCACAGCCAAGGCAATTGCCAAGGGAGTGGGCATCATCTCAGAGGGCA 1924

ATP1A3 (1of2)-2 ACGAGACAGTGGAGGACATTGCAGCCCGTCTCAACATACCAGTCAGCCAAGTCAACCCCA 2226
 ATP1A3 (1of2)-3 ACGAGACAGTGGAGGACATTGCAGCCCGTCTCAACATACCAGTCAGCCAAGTCAACCCCA 2266
 ATP1A3 (1of2)-4 ACGAGACAGTGGAGGACATTGCAGCCCGTCTCAACATACCAGTCAGCCAAGTCAACCCCA 1972
 ATP1A3 (1of2)-1 ACGAGACAGTGGAGGACATTGCAGCCCGTCTCAACATACCAGTCAGCCAAGTCAACCCCA 1984

ATP1A3 (1of2)-2 GGGATGCCAAGGCCTGTGTGTGCCACGGTACAGATCTAAAGGATCTGTCTCAGGATCAGA 2286
 ATP1A3 (1of2)-3 GGGATGCCAAGGCCTGTGTGTGCCACGGTACAGATCTAAAGGATCTGTCTCAGGATCAGA 2326
 ATP1A3 (1of2)-4 GGGATGCCAAGGCCTGTGTGTGCCACGGTACAGATCTAAAGGATCTGTCTCAGGATCAGA 2032
 ATP1A3 (1of2)-1 GGGATGCCAAGGCCTGTGTGTGCCACGGTACAGATCTAAAGGATCTGTCTCAGGATCAGA 2044

ATP1A3 (1of2)-2 TGGACGACATCCTGAGGAATCACACGGAGATCGTCTTTGCTAGGACCTCCCCACAGCAGA 2346
 ATP1A3 (1of2)-3 TGGACGACATCCTGAGGAATCACACGGAGATCGTCTTTGCTAGGACCTCCCCACAGCAGA 2386
 ATP1A3 (1of2)-4 TGGACGACATCCTGAGGAATCACACGGAGATCGTCTTTGCTAGGACCTCCCCACAGCAGA 2092
 ATP1A3 (1of2)-1 TGGACGACATCCTGAGGAATCACACGGAGATCGTCTTTGCTAGGACCTCCCCACAGCAGA 2104

ATP1A3 (1of2)-2 AGCTCATCATCGTAGAAGGCTGCCAGAGACTGGGTGCCATTGTGGCTGTGACAGGTGATG 2406
 ATP1A3 (1of2)-3 AGCTCATCATCGTAGAAGGCTGCCAGAGACTGGGTGCCATTGTGGCTGTGACAGGTGATG 2446
 ATP1A3 (1of2)-4 AGCTCATCATCGTAGAAGGCTGCCAGAGACTGGGTGCCATTGTGGCTGTGACAGGTGATG 2152
 ATP1A3 (1of2)-1 AGCTCATCATCGTAGAAGGCTGCCAGAGACTGGGTGCCATTGTGGCTGTGACAGGTGATG 2164

ATP1A3 (1of2)-2 GTGTGAATGACTCACCTGCTCTGAAAAAGGCCGACATTGGTGTGCCATGGGAATCTCTG 2466
 ATP1A3 (1of2)-3 GTGTGAATGACTCACCTGCTCTGAAAAAGGCCGACATTGGTGTGCCATGGGAATCTCTG 2506
 ATP1A3 (1of2)-4 GTGTGAATGACTCACCTGCTCTGAAAAAGGCCGACATTGGTGTGCCATGGGAATCTCTG 2212
 ATP1A3 (1of2)-1 GTGTGAATGACTCACCTGCTCTGAAAAAGGCCGACATTGGTGTGCCATGGGAATCTCTG 2224

ATP1A3 (1of2)-2 GCTCCGATGTGTCCAAACAGGCCGAGACATGATCTTGTGGATGACAACCTTTGCCTCTA 2526
 ATP1A3 (1of2)-3 GCTCCGATGTGTCCAAACAGGCCGAGACATGATCTTGTGGATGACAACCTTTGCCTCTA 2566
 ATP1A3 (1of2)-4 GCTCCGATGTGTCCAAACAGGCCGAGACATGATCTTGTGGATGACAACCTTTGCCTCTA 2272
 ATP1A3 (1of2)-1 GCTCCGATGTGTCCAAACAGGCCGAGACATGATCTTGTGGATGACAACCTTTGCCTCTA 2284

ATP1A3 (1of2)-2 TTGTCACAGGAGTTGAAGAAGGCCGTTTGTATCTTTGACAACCTCAAGAAGTCCATTGCCT 2586
 ATP1A3 (1of2)-3 TTGTCACAGGAGTTGAAGAAGGCCGTTTGTATCTTTGACAACCTCAAGAAGTCCATTGCCT 2626
 ATP1A3 (1of2)-4 TTGTCACAGGAGTTGAAGAAGGCCGTTTGTATCTTTGACAACCTCAAGAAGTCCATTGCCT 2332
 ATP1A3 (1of2)-1 TTGTCACAGGAGTTGAAGAAGGCCGTTTGTATCTTTGACAACCTCAAGAAGTCCATTGCCT 2344

ATP1A3 (1of2)-2 ACACCTTGACCAGCAACATCCCAGAGATCACCCCCTTCTGCTGTTTCATCATCGTCAACA 2646
 ATP1A3 (1of2)-3 ACACCTTGACCAGCAACATCCCAGAGATCACCCCCTTCTGCTGTTTCATCATCGTCAACA 2686
 ATP1A3 (1of2)-4 ACACCTTGACCAGCAACATCCCAGAGATCACCCCCTTCTGCTGTTTCATCATCGTCAACA 2392
 ATP1A3 (1of2)-1 ACACCTTGACCAGCAACATCCCAGAGATCACCCCCTTCTGCTGTTTCATCATCGTCAACA 2404

ATP1A3 (1of2)-2 TCCCCCTGCCACTGGGAACCATCACCATCCTCTGCATCGACCTGGGAACCGACATGGTTC 2706
 ATP1A3 (1of2)-3 TCCCCCTGCCACTGGGAACCATCACCATCCTCTGCATCGACCTGGGAACCGACATGGTTC 2746
 ATP1A3 (1of2)-4 TCCCCCTGCCACTGGGAACCATCACCATCCTCTGCATCGACCTGGGAACCGACATGGTTC 2452
 ATP1A3 (1of2)-1 TCCCCCTGCCACTGGGAACCATCACCATCCTCTGCATCGACCTGGGAACCGACATGGTTC 2464

ATP1A3 (1of2)-2 CAGCCATCTCACTGGCCTATGAAGCAGCCGAGAGCGACATCATGAAGCGTCAGCCAGGA 2766
 ATP1A3 (1of2)-3 CAGCCATCTCACTGGCCTATGAAGCAGCCGAGAGCGACATCATGAAGCGTCAGCCAGGA 2806
 ATP1A3 (1of2)-4 CAGCCATCTCACTGGCCTATGAAGCAGCCGAGAGCGACATCATGAAGCGTCAGCCAGGA 2512
 ATP1A3 (1of2)-1 CAGCCATCTCACTGGCCTATGAAGCAGCCGAGAGCGACATCATGAAGCGTCAGCCAGGA 2524

ATP1A3 (1of2)-2 ACCCATT CAGGGACAAGCTGGTGAATGAGAGGCTTATCAGCATTGCCTACGGACAAATCG 2826
 ATP1A3 (1of2)-3 ACCCATT CAGGGACAAGCTGGTGAATGAGAGGCTTATCAGCATTGCCTACGGACAAATCG 2866
 ATP1A3 (1of2)-4 ACCCATT CAGGGACAAGCTGGTGAATGAGAGGCTTATCAGCATTGCCTACGGACAAATCG 2572
 ATP1A3 (1of2)-1 ACCCATT CAGGGACAAGCTGGTGAATGAGAGGCTTATCAGCATTGCCTACGGACAAATCG 2584

ATP1A3 (1of2)-2 GTATGATCCAGGCTCTGGGAGGCTTCTTCGCC TACTTTGTCATCTTGGCTGAAAACGGTT 2886
 ATP1A3 (1of2)-3 GTATGATCCAGGCTCTGGGAGGCTTCTTCGCC TACTTTGTCATCTTGGCTGAAAACGGTT 2926
 ATP1A3 (1of2)-4 GTATGATCCAGGCTCTGGGAGGCTTCTTCGCC TACTTTGTCATCTTGGCTGAAAACGGTT 2632
 ATP1A3 (1of2)-1 GTATGATCCAGGCTCTGGGAGGCTTCTTCGCC TACTTTGTCATCTTGGCTGAAAACGGTT 2644

ATP1A3 (1of2)-2 TCCTGCCAACTACACTAGTCGGCATCAGGCTCAAT TGGGACGACCGCAGTTGTAACGACT 2946
 ATP1A3 (1of2)-3 TCCTGCCAACTACACTAGTCGGCATCAGGCTCAAT TGGGACGACCGCAGTTGTAACGACT 2986
 ATP1A3 (1of2)-4 TCCTGCCAACTACACTAGTCGGCATCAGGCTCAAT TGGGACGACCGCAGTTGTAACGACT 2692
 ATP1A3 (1of2)-1 TCCTGCCAACTACACTAGTCGGCATCAGGCTCAAT TGGGACGACCGCAGTTGTAACGACT 2704

ATP1A3 (1of2)-2 TGG AAGACACCTACGGGCAACAATGGACATATGAGCAGAGGAAGATTGTGGAGTTCACAT 3006
 ATP1A3 (1of2)-3 TGG AAGACACCTACGGGCAACAATGGACATATGAGCAGAGGAAGATTGTGGAGTTCACAT 3046
 ATP1A3 (1of2)-4 TGG AAGACACCTACGGGCAACAATGGACATATGAGCAGAGGAAGATTGTGGAGTTCACAT 2752
 ATP1A3 (1of2)-1 TGG AAGACACCTACGGGCAACAATGGACATATGAGCAGAGGAAGATTGTGGAGTTCACAT 2764

ATP1A3 (1of2)-2 GCCACACAGCCTTCTTTGTG CAGCATTTGTGGTCGTGCAATGGGCTGACGTCATCATCTGCA 3066
 ATP1A3 (1of2)-3 GCCACACAGCCTTCTTTGTG CAGCATTTGTGGTCGTGCAATGGGCTGACGTCATCATCTGCA 3106
 ATP1A3 (1of2)-4 GCCACACAGCCTTCTTTGTG CAGCATTTGTGGTCGTGCAATGGGCTGACGTCATCATCTGCA 2812
 ATP1A3 (1of2)-1 GCCACACAGCCTTCTTTGTG CAGCATTTGTGGTCGTGCAATGGGCTGACGTCATCATCTGCA 2824

ATP1A3 (1of2)-2 AGACCAGGCGTAATTCTGTGTTCCAGCAGGGCATGAGGAACAAGATCTTGATCTTCGGCC 3126
 ATP1A3 (1of2)-3 AGACCAGGCGTAATTCTGTGTTCCAGCAGGGCATGAGGAACAAGATCTTGATCTTCGGCC 3166
 ATP1A3 (1of2)-4 AGACCAGGCGTAATTCTGTGTTCCAGCAGGGCATGAGGAACAAGATCTTGATCTTCGGCC 2872
 ATP1A3 (1of2)-1 AGACCAGGCGTAATTCTGTGTTCCAGCAGGGCATGAGGAACAAGATCTTGATCTTCGGCC 2884

ATP1A3 (1of2)-2 TGTTTGAAGAGACCGCTCTGGCTGCCTTCTGTCTACTGCCAGGCATGGATGTGGCAC 3186
 ATP1A3 (1of2)-3 TGTTTGAAGAGACCGCTCTGGCTGCCTTCTGTCTACTGCCAGGCATGGATGTGGCAC 3226
 ATP1A3 (1of2)-4 TGTTTGAAGAGACCGCTCTGGCTGCCTTCTGTCTACTGCCAGGCATGGATGTGGCAC 2932
 ATP1A3 (1of2)-1 TGTTTGAAGAGACCGCTCTGGCTGCCTTCTGTCTACTGCCAGGCATGGATGTGGCAC 2944

ATP1A3 (1of2)-2 TCAGGATGTATCCACTAAAGCCTAGCTGGTGGTTTTGTGCGTTCCCCTATAGTTTCTTA 3246
 ATP1A3 (1of2)-3 TCAGGATGTATCCACTAAAGCCTAGCTGGTGGTTTTGTGCGTTCCCCTATAGTTTCTTA 3286
 ATP1A3 (1of2)-4 TCAGGATGTATCCACTAAAGCCTAGCTGGTGGTTTTGTGCGTTCCCCTATAGTTTCTTA 2992
 ATP1A3 (1of2)-1 TCAGGATGTATCCACTAAAGCCTAGCTGGTGGTTTTGTGCGTTCCCCTATAGTTTCTTA 3004

ATP1A3 (1of2)-2 TCTTTGTCTATGATGAGGTGCGAAAACCTTCTCATTCGTCGGAACCCCGGAGGTTGGGTGG 3306
 ATP1A3 (1of2)-3 TCTTTGTCTATGATGAGGTGCGAAAACCTTCTCATTCGTCGGAACCCCGGAGGTTGGGTGG 3346
 ATP1A3 (1of2)-4 TCTTTGTCTATGATGAGGTGCGAAAACCTTCTCATTCGTCGGAACCCCGGAGGTTGGGTGG 3052
 ATP1A3 (1of2)-1 TCTTTGTCTATGATGAGGTGCGAAAACCTTCTCATTCGTCGGAACCCCGGAGGTTGGGTGG 3064

ATP1A3 (1of2)-2 AAAGAGAGACATACTATTGA----- 3326
 ATP1A3 (1of2)-3 AAAGAGAGACATACTATTGA----- 3366
 ATP1A3 (1of2)-4 AAAGAGAGACATACTATTGA----- 3072
 ATP1A3 (1of2)-1 AAAGAGAGACATACTATTGATCAATGGAGCATCTTTGCTCAAGCCCCCACATGTTCCAA 3124

ATP1A3 (1of2)-2 -----
 ATP1A3 (1of2)-3 -----
 ATP1A3 (1of2)-4 -----
 ATP1A3 (1of2)-1 TTATTTCTCCCCCTGTCACTCCATCCCTGGCAAGACACCCCTTCCGATGCCCGCCCC 3184

ATP1A3 (1of2)-2 -----
 ATP1A3 (1of2)-3 -----
 ATP1A3 (1of2)-4 -----
 ATP1A3 (1of2)-1 TTAAAAATACAAAACGCTTTAAAGCAATTTTCATCACAACCTGCCCAAAGATTAAAAACA 3244

ATP1A3 (1of2)-2 -----
 ATP1A3 (1of2)-3 -----
 ATP1A3 (1of2)-4 -----
 ATP1A3 (1of2)-1 GCAAAAACACCTTTACAACCTTTCTACATTGACCCGCCCTTTCTCCCATCTCTATGA 3304

ATP1A3 (1of2)-2 -----
 ATP1A3 (1of2)-3 -----
 ATP1A3 (1of2)-4 -----
 ATP1A3 (1of2)-1 TACTCTTTGCATG 3317

ATP1A3 (2 of 2)

ATP1A3 (2of2)-1 ATCGTTTGCGCCTTTCGGGAGAGGAGGCTGGTTCGAAGTGCCACCGACGGCTGCTTACGAA 60
 ATP1A3 (2of2)-2 -----GGTTCGAAGTGCCACCGACGGCTGCTTACGAA 31

ATP1A3 (2of2)-1 TTATAAACATTTTATGCCGAAGAAATAAACCCTTTTCATTTTCATCTCAACGGGGTGCCA 120
 ATP1A3 (2of2)-2 TTATAAACATTTTATGCCGAAGAAATAAACCCTTTTCATTTTCATCTCAACGGG----- 85

ATP1A3 (2of2)-1 AAAGATTTTTTTGCTTTGTCAAATGACCGTATGCCCGTTCCCTCGTTTAGCGCGTAATGT 180
 ATP1A3 (2of2)-2 -----

ATP1A3 (2of2)-1 GGGCTAGTTAATTGATTTGTGTCAAGTACCGTTAGCTGTCAACTGAAGGGAGA 240
 ATP1A3 (2of2)-2 -----

ATP1A3 (2of2)-1 CATTTTTATTTCTCATCACCAGACGGCTGTTTGTGCCCAACAATCCGCCTTAAAGCTTC 300
 ATP1A3 (2of2)-2 -----ACGGCTGTTTGTGCCCAACAATCCGCCTTAAAGCTTC 123

ATP1A3 (2of2)-1 TCTGCTCGAACCCCTCAACGCGGCTCATCGGCTGAGGAGACCCGGCTGACTGCGCCGAAAT 360
ATP1A3 (2of2)-2 TCTGCTCGAACCCCTCAACGCGGCTCATCGGCTGAGGAGACCCGGCTGACTGCGCCGAAAT 183

ATP1A3 (2of2)-1 GGGGTACGGACGGTCGGACAGCTACCGCGTGGCCACCACGCAGGACAAGGATGAGAAGGA 420
ATP1A3 (2of2)-2 GGGGTACGGACGGTCGGACAGCTACCGCGTGGCCACCACGCAGGACAAGGATGAGAAGGA 243

ATP1A3 (2of2)-1 GTCGCCAAGAAGAAGGCCGGCAAGGACATGGATGACCTCAAAAAGGAAGTCCCCATCAC 480
ATP1A3 (2of2)-2 GTCGCCAAGAAGAAGGCCGGCAAGGACATGGATGACCTCAAAAAGGAAGTCCCCATCAC 303

ATP1A3 (2of2)-1 GGAACACAAAATGCTCTGTTGAGGAGGTTTGCCGAAATACAGCACTGATATCGTCCAGGG 540
ATP1A3 (2of2)-2 GGAACACAAAATGCTCTGTTGAGGAGGTTTGCCGAAATACAGCACTGATATCGTCCAGGG 363

ATP1A3 (2of2)-1 TTTGACCAACGCCAAGGCAGCAGGTACCTGATCAGGGACGGCCCAACGCCCTGACCCC 600
ATP1A3 (2of2)-2 TTTGACCAACGCCAAGGCAGCAGGTACCTGATCAGGGACGGCCCAACGCCCTGACCCC 423

ATP1A3 (2of2)-1 GCCCCCCACCACCCAGAGTGGGTCAAGTTTTGTGCGCAGCTGTTCGGCGGCTTCTCCAT 660
ATP1A3 (2of2)-2 GCCCCCCACCACCCAGAGTGGGTCAAGTTTTGTGCGCAGCTGTTCGGCGGCTTCTCCAT 483

ATP1A3 (2of2)-1 CCTGCTGTGGATCGGCGCCATCCTCTGCTTCTGGCTACGCCATCCAGGCGGCCACGGA 720
ATP1A3 (2of2)-2 CCTGCTGTGGATCGGCGCCATCCTCTGCTTCTGGCTACGCCATCCAGGCGGCCACGGA 543

ATP1A3 (2of2)-1 GGACGAGCCCGCTGGCGATAAATTGTATCTGGGCATCGTGCTGTCAGCCGTCGTCATCAT 780
ATP1A3 (2of2)-2 GGACGAGCCCGCTGGCGATAAATTGTATCTGGGCATCGTGCTGTCAGCCGTCGTCATCAT 603

ATP1A3 (2of2)-1 CACCGGTTGCTTCTCCTACTTTTCAGGAGGCGAAGAGCTCCAAGATCATGGAGTCCCTCAA 840
ATP1A3 (2of2)-2 CACCGGTTGCTTCTCCTACTTTTCAGGAGGCGAAGAGCTCCAAGATCATGGAGTCCCTCAA 663

ATP1A3 (2of2)-1 GAACATGGTTCCTCAGCAAGCCCTGGTGATCCGTGAGGGAGAGAAGATGCAGATCAATGC 900
ATP1A3 (2of2)-2 GAACATGGTTCCTCAGCAAGCCCTGGTGATCCGTGAGGGAGAGAAGATGCAGATCAATGC 723

ATP1A3 (2of2)-1 GGAGCAAGTGGTGGCAGGAGACCTGGTGGAGGTGAAAGGAGGAGACAGGATCCCTGCCGA 960
ATP1A3 (2of2)-2 GGAGCAAGTGGTGGCAGGAGACCTGGTGGAGGTGAAAGGAGGAGACAGGATCCCTGCCGA 783

ATP1A3 (2of2)-1 CCTCCGCATCGTCTCCTCCACGGCTGCAAGGTGGACAACCTCATCCCTGACCGGCGAATC 1020
ATP1A3 (2of2)-2 CCTCCGCATCGTCTCCTCCACGGCTGCAAGGTGGACAACCTCATCCCTGACCGGCGAATC 843

ATP1A3 (2of2)-1 AGAGCCCAGACCAGGTACCTGACGGTACCCATGACAACCCCTTGAAACCCGCAACAT 1080
ATP1A3 (2of2)-2 AGAGCCCAGACCAGGTACCTGACGGTACCCATGACAACCCCTTGAAACCCGCAACAT 903

ATP1A3 (2of2)-1 CGCCTTCTTCTCCACCAACTGTGTCGAGGGAACGGCGCGCGGCATCGTGTGTGCACTGG 1140
ATP1A3 (2of2)-2 CGCCTTCTTCTCCACCAACTGTGTCGAGGGAACGGCGCGCGGCATCGTGTGTGCACTGG 963

ATP1A3 (2of2)-1 CGATCGCACGGTGTGGGCCGATCGCCACTCTGACCTCAGGCTGGAGACCGGCAAGAC 1200
ATP1A3 (2of2)-2 CGATCGCACGGTGTGGGCCGATCGCCACTCTGACCTCAGGCTGGAGACCGGCAAGAC 1023

ATP1A3 (2of2)-1 TCCCATTGCCAAGGAGATCGAGCACTTCATCCAGATCATCACAGGCGTGGCCGCTTCTCT 1260
 ATP1A3 (2of2)-2 TCCCATTGCCAAGGAGATCGAGCACTTCATCCAGATCATCACAGGCGTGGCCGCTTCTCT 1083

ATP1A3 (2of2)-1 CGGCATGTCCTTCTTCGTGCTGTCAATCGTCCGTTACTCCTGGCTGGAAGCCGTCAT 1320
 ATP1A3 (2of2)-2 CGGCATGTCCTTCTTCGTGCTGTCAATCGTCCGTTACTCCTGGCTGGAAGCCGTCAT 1143

ATP1A3 (2of2)-1 CTTCTCATTGGCATCATTGTTGCTAATGTGCCGAGGGTCTGCTCGCCACAGTCACCGT 1380
 ATP1A3 (2of2)-2 CTTCTCATTGGCATCATTGTTGCTAATGTGCCGAGGGTCTGCTCGCCACAGTCACCGT 1203

ATP1A3 (2of2)-1 TTGTCTGACACTGACGGCTAAGCGAATGGCTCGCAAGAAGTGCCTGGTGAAGAAGTGGGA 1440
 ATP1A3 (2of2)-2 TTGTCTGACACTGACGGCTAAGCGAATGGCTCGCAAGAAGTGCCTGGTGAAGAAGTGGGA 1263

ATP1A3 (2of2)-1 GGCTGTGGAACACTGGGCTCCACCTCCACCATCTGCTCCGACAAGACGGGCACGCTGAC 1500
 ATP1A3 (2of2)-2 GGCTGTGGAACACTGGGCTCCACCTCCACCATCTGCTCCGACAAGACGGGCACGCTGAC 1323

ATP1A3 (2of2)-1 CCAGAACCGCATGACCGTGGCCACATGTGGTTCGACAACCAGATCCACGAGGCCGACAC 1560
 ATP1A3 (2of2)-2 CCAGAACCGCATGACCGTGGCCACATGTGGTTCGACAACCAGATCCACGAGGCCGACAC 1383

ATP1A3 (2of2)-1 CACCGAGGACCAGTCCGGCTGCTCCTTCGACAAAAGCTCCACCAGTGGGTGTCTTTGGC 1620
 ATP1A3 (2of2)-2 CACCGAGGACCAGTCCGGCTGCTCCTTCGACAAAAGCTCCACCAGTGGGTGTCTTTGGC 1443

ATP1A3 (2of2)-1 CCGCATCGCTGCCCTGTGCAACCGCGCTGTGTTCAAGCCGGCCAGGACGCTTTGCCCAT 1680
 ATP1A3 (2of2)-2 CCGCATCGCTGCCCTGTGCAACCGCGCTGTGTTCAAGCCGGCCAGGACGCTTTGCCCAT 1503

ATP1A3 (2of2)-1 CCTGAAGCGCGATGTGGCCGGCGACGCTCCGAGTCCGCCCTGCTGAAGTGTATCGAGCT 1740
 ATP1A3 (2of2)-2 CCTGAAGCGCGATGTGGCCGGCGACGCTCCGAGTCCGCCCTGCTGAAGTGTATCGAGCT 1563

ATP1A3 (2of2)-1 GTCCCTGTGGCTCCGTCAAAGCCATGAGGGAGAAGAACAAGAAGGTGGCCGAGATCCCCTT 1800
 ATP1A3 (2of2)-2 GTCCCTGTGGCTCCGTCAAAGCCATGAGGGAGAAGAACAAGAAGGTGGCCGAGATCCCCTT 1623

ATP1A3 (2of2)-1 CAACTCCACCAACAAGTACCAGCTCTCCATTTCATGAAAATGACGATGAAAACGACAACCG 1860
 ATP1A3 (2of2)-2 CAACTCCACCAACAAGTACCAGCTCTCCATTTCATGAAAATGACGATGAAAACGACAACCG 1683

ATP1A3 (2of2)-1 CTACCTGCTGGTGTGAAGGGAGCTCCGAGAGGATCCTCGACCAGCTCCACCATCAT 1920
 ATP1A3 (2of2)-2 CTACCTGCTGGTGTGAAGGGAGCTCCGAGAGGATCCTCGACCAGCTCCACCATCAT 1743

ATP1A3 (2of2)-1 GTTGCAAGGCAAGGAGCAGCCATGGACGACGAGATGAAAGAGGCCCTTCCAGAAGTCCCTA 1980
 ATP1A3 (2of2)-2 GTTGCAAGGCAAGGAGCAGCCATGGACGACGAGATGAAAGAGGCCCTTCCAGAAGTCCCTA 1803

ATP1A3 (2of2)-1 CCAGGAACTGGGCGGACTGGGAGAGAGGGTACTGGGTTTCTGCCACGTGTTCTGCCAGA 2040
 ATP1A3 (2of2)-2 CCAGGAACTGGGCGGACTGGGAGAGAGGGTACTGGGTTTCTGCCACGTGTTCTGCCAGA 1863

ATP1A3 (2of2)-1 GGACAAGTACCCCAAGGGCTTCGCCTTCGACACAGACGACGCTCAACTTCGAGACGGACAA 2100
 ATP1A3 (2of2)-2 GGACAAGTACCCCAAGGGCTTCGCCTTCGACACAGACGACGCTCAACTTCGAGACGGACAA 1923

ATP1A3 (2of2)-1 CCTTTGCTTCGTAGGCTCATGTCCATGATCGACCCTCCGCGTGTGCGGTGCTGCGTGCCTGATGC 2160
 ATP1A3 (2of2)-2 CCTTTGCTTCGTAGGCTCATGTCCATGATCGACCCTCCGCGTGTGCGGTGCTGCGTGCCTGATGC 1983

ATP1A3 (2of2)-1 TGTGGGCAAATGCCGCTCTGCAGGCATCAAGGTAATTATGGTGAAGTGGTGACCACCCAAT 2220
 ATP1A3 (2of2)-2 TGTGGGCAAATGCCGCTCTGCAGGCATCAAGGTAATTATGGTGAAGTGGTGACCACCCAAT 2043

ATP1A3 (2of2)-1 CACAGCCAAGGCTATTGCTAAGGGTGTGGGCATCATCTCCGAGGGTAACGAGACAGTGGGA 2280
 ATP1A3 (2of2)-2 CACAGCCAAGGCTATTGCTAAGGGTGTGGGCATCATCTCCGAGGGTAACGAGACAGTGGGA 2103

ATP1A3 (2of2)-1 AGACATTGCTGCACGCCTCAACATCCCCATCAGCCAAGTCAACCCAAGGGACGCCAAGGC 2340
 ATP1A3 (2of2)-2 AGACATTGCTGCACGCCTCAACATCCCCATCAGCCAAGTCAACCCAAGGGACGCCAAGGC 2163

ATP1A3 (2of2)-1 CTGTGTGATCCACGGCACCGACCTGAAAGACCTCGATCAGGGGGCGATGGACGATATTTT 2400
 ATP1A3 (2of2)-2 CTGTGTGATCCACGGCACCGACCTGAAAGACCTCGATCAGGGGGCGATGGACGATATTTT 2223

ATP1A3 (2of2)-1 GAAGAACCACACTGAGATTGTCTTTGCCCGAACCTCCCCGCAGCAGAAGCTCATCATCGT 2460
 ATP1A3 (2of2)-2 GAAGAACCACACTGAGATTGTCTTTGCCCGAACCTCCCCGCAGCAGAAGCTCATCATCGT 2283

ATP1A3 (2of2)-1 AGAAGGCTGCCAGCGGCAGGGCGCCATCGTGGCCGTGACGGGGCAGCGGTGTGAACGACTC 2520
 ATP1A3 (2of2)-2 AGAAGGCTGCCAGCGGCAGGGCGCCATCGTGGCCGTGACGGGGCAGCGGTGTGAACGACTC 2343

ATP1A3 (2of2)-1 ACCCGCCTGAAGAAGGCTGACATCGGCGTCGCCATGGGAATCTCCGGCTCCGACGTGTC 2580
 ATP1A3 (2of2)-2 ACCCGCCTGAAGAAGGCTGACATCGGCGTCGCCATGGGAATCTCCGGCTCCGACGTGTC 2403

ATP1A3 (2of2)-1 CAAACAGGCTGCCGACATGATCCTGTGCTGGACGACAACCTTCGCCTCCATCGTCACAGGA-- 2638
 ATP1A3 (2of2)-2 CAAACAGGCTGCCGACATGATCCTGTGCTGGACGACAACCTTCGCCTCCATCGTCACCTC 2463

ATP1A3 (2of2)-1 ---GTGGAGGAAGGCCGTCTGATCTTCGACAACCTGAAGAAGTCCATCGCGTACACTCT 2694
 ATP1A3 (2of2)-2 CTTTCATCACTACAGGCCGTCTGATCTTCGACAACCTGAAGAAGTCCATCGCGTACACTCT 2523
 * *****

ATP1A3 (2of2)-1 GACCAGCAACATCCCAGAGATCACCCCTTCTGTTCTTCATCCTGGTCAACATCCCCT 2754
 ATP1A3 (2of2)-2 GACCAGCAACATCCCAGAGATCACCCCTTCTGTTCTTCATCCTGGTCAACATCCCCT 2583

ATP1A3 (2of2)-1 GCCTCTGGGCACCATCACCATCCTCTGCATTGACCTGGGAACAGACATGGTACCAGCCAT 2814
 ATP1A3 (2of2)-2 GCCTCTGGGCACCATCACCATCCTCTGCATTGACCTGGGAACAGACATGGTACCAGCCAT 2643

ATP1A3 (2of2)-1 CTCTCTCGCCTACGAAGCGGCAGAGAGCGACATCATGAAGCGGCAGCCAGGAACCCACA 2874
 ATP1A3 (2of2)-2 CTCTCTCGCCTACGAAGCGGCAGAGAGCGACATCATGAAGCGGCAGCCAGGAACCCACA 2703

ATP1A3 (2of2)-1 GAGGGACAAACTGGTCAACGAGAGACTCATCAGTATCGCCTATGGACAGATCGGTATGAT 2934
 ATP1A3 (2of2)-2 GAGGGACAAACTGGTCAACGAGAGACTCATCAGTATCGCCTATGGACAGATCGGTATGAT 2763

ATP1A3 (2of2)-1 CCAAGCTCTCGGCGGGTCTTTGTCATATTTTCGTCATCATGGCTGAAAACGGTTTCTGTC 2994
 ATP1A3 (2of2)-2 CCAAGCTCTCGGCGGGTCTTTGTCATATTTTCGTCATCATGGCTGAAAACGGTTTCTGTC 2823

ATP1A3 (2of2)-1 GTCCGAGCTCGTCCGCATCCGGCTCAACTGGGACGATCGCTCCAACAACGACCTGGAGGA 3054
 ATP1A3 (2of2)-2 GTCCGAGCTCGTCCGCATCCGGCTCAACTGGGACGATCGCTCCAACAACGACCTGGAGGA 2883

ATP1A3 (2of2)-1 CAGCTACGGGCAGCAATGGACCTATGAGCAGCGGAAGATCGTGGAGTTTACCTGCCACAC 3114
 ATP1A3 (2of2)-2 CAGCTACGGGCAGCAATGGACCTATGAGCAGCGGAAGATCGTGGAGTTTACCTGCCACAC 2943

ATP1A3 (2of2)-1 GCGTTCCTTCGTCAGCATCGTGGTGGTGCAGTGGGCAGATGTATCATCTGCAAGACCAG 3174
 ATP1A3 (2of2)-2 GCGTTCCTTCGTCAGCATCGTGGTGGTGCAGTGGGCAGATGTATCATCTGCAAGACCAG 3003

ATP1A3 (2of2)-1 GCGTAACTCTGTGTTCCAGCAGGGCATGAAGAATAAGATTTTGTATCTTTGGGCTGTTTGA 3234
 ATP1A3 (2of2)-2 GCGTAACTCTGTGTTCCAGCAGGGCATGAAGAATAAGATTTTGTATCTTTGGGCTGTTTGA 3063

ATP1A3 (2of2)-1 GGAAACGGCTCTGGCTGCTCTGCTGTCTACTGCCCGGCATGGACGTGGCCCTGCGGAT 3294
 ATP1A3 (2of2)-2 GGAAACGGCTCTGGCTGCTCTGCTGTCTACTGCCCGGCATGGACGTGGCCCTGCGGAT 3123

ATP1A3 (2of2)-1 GTACCCGCTCAAGCCCAGCTGGTGGTTCGTGCGTTCCTGACAGCTTCCTCATCTTTGT 3354
 ATP1A3 (2of2)-2 GTACCCGCTCAAGCCCAGCTGGTGGTTCGTGCGTTCCTGACAGCTTCCTCATCTTTGT 3183

ATP1A3 (2of2)-1 TTACGATGAAATCCGAAACTCATCCTTCGCCGAAACCCCGGAGGCTGGGTGGAAAGAGA 3414
 ATP1A3 (2of2)-2 TTACGATGAAATCCGAAACTCATCCTTCGCCGAAACCCCGGAGGCTGGGTGGAAAGAGA 3243

ATP1A3 (2of2)-1 GACCTACTATTAGATTAGCAAAGCATCATTTCTCTCAATGTGCCCCCTCTCTCTCTCT 3474
 ATP1A3 (2of2)-2 GACCTACTATTAG----- 3256

ATP1A3 (2of2)-1 CCTTCTCTCCCCATCCCTCCTCACCCGTCAACATGCTCTATACAAGAAGATGACGTCCC 3534
 ATP1A3 (2of2)-2 -----

ATP1A3 (2of2)-1 ACCCATCCTCCTCTCAACCCGCATCGCCACAAGAAACACAAAAACCAACAGGACTAATG 3594
 ATP1A3 (2of2)-2 -----

ATP1A3 (2of2)-1 AGACAGGGGAGGGCAGGGGGGTACAACCTCTTCGTCCTGTCTCTGTCCCCCTTTTATT 3654
 ATP1A3 (2of2)-2 -----

ATP1A3 (2of2)-1 TTTTCTATTCAAAGTCTCTACAGCACTTGACCGCCAGTAACACCGTCCGTGCTGCACCGCT 3714
 ATP1A3 (2of2)-2 -----

ATP1A3 (2of2)-1 GTGTGTGGACCGCCATGGAGAAGGAGAAGGTCCGACTGTTCCACGGCCATCTTTGTCCC 3774
 ATP1A3 (2of2)-2 -----

ATP1A3 (2of2)-1 AGCAGAACCACAAAGGGGCAACTCCTGTCTCCACCCTGTCCACACTGGTGTCTCCACTG 3834
 ATP1A3 (2of2)-2 -----

ATP1A3 (2of2)-1 CTGTCTCCAACCTCAGTTTCTGCTTCAAGAAAAGTTCAACAATCATTTGCACCCTCAACT 3894
 ATP1A3 (2of2)-2 -----

ATP1A3 (2of2)-1 GGGTGGAGAAAAAGTCACCCCCCCCATGCGTTTTTTTTCTGCCTGTGTTGTTGTTT 3954
 ATP1A3 (2of2)-2 -----

ATP1A3 (2of2)-1 TCTAAAAGACAACCTGGCTGTTTAGAAAAATAAAAAATAGTTTGTGAAAGTTC 4005
 ATP1A3 (2of2)-2 -----

Appendix 2: cDNA Similarity Matrix for Na⁺/K⁺-ATPase α Subunit Isoform Transcripts

cDNA Similarity										
Isoform Transcript	ATP1A-1	ATP1A-2	ATP1A-3	ATP1A-4	ATP1A3 (1of 2)-1	ATP1A3 (1of 2)-2	ATP1A3 (1of 2)-3	ATP1A3 (1of 2)-4	ATP1A3 (2of2)-1	ATP1A3 (2of2)-2
ATP1A-1	100	89.0	98.0	86.0	76.0	76.0	77.0	79.0	76.0	76.0
ATP1A-2		100	91.0	87.0	72.0	72.0	71.0	78.0	72.0	74.0
ATP1A-3			100	85.0	78.0	76.0	76.0	79.0	78.0	75.0
ATP1A-4				100	78.0	79.0	79.0	78.0	78.0	80.0
ATP1A3 (1of 2)-1					100	92.0	92.0	99.0	82.0	79.0
ATP1A3 (1of 2)-2						100	96.0	99.0	81.0	81.0
ATP1A3 (1of 2)-3							100	99.0	81.0	81.0
ATP1A3 (1of 2)-4								100	84.0	83.0
ATP1A3 (2of2)-1									100	99.0
ATP1A3 (2of2)-1										100