

World Maritime University

The Maritime Commons: Digital Repository of the World Maritime University

World Maritime University Dissertations

Dissertations

1996

The technical and economical aspects of marine engine selection

Gopi Mohan Saha
WMU

Follow this and additional works at: https://commons.wmu.se/all_dissertations

Recommended Citation

Saha, Gopi Mohan, "The technical and economical aspects of marine engine selection" (1996). *World Maritime University Dissertations*. 1052.

https://commons.wmu.se/all_dissertations/1052

This Dissertation is brought to you courtesy of Maritime Commons. Open Access items may be downloaded for non-commercial, fair use academic purposes. No items may be hosted on another server or web site without express written permission from the World Maritime University. For more information, please contact library@wmu.se.

1484

WORLD MARITIME UNIVERSITY
Malmö, Sweden

**THE TECHNICAL AND ECONOMICAL
ASPECTS OF MARINE ENGINE SELECTION**

By

SAHA GOPI MOHAN
People's Republic of Bangladesh

A dissertation submitted to the World Maritime University in partial
fulfilment of the requirements for the award of the degree of

MASTER OF SCIENCE

in

MARITIME EDUCATION AND TRAINING
(Engineering)

Year of graduation
1996

DECLARATION

I certify that all the material in this dissertation that is not my own work has been identified, and that no material is included for which a degree has previously been conferred on me.

The contents of this dissertation reflect my own personal views, and are not necessarily endorsed by the University.



Saha Gopi Mohan

18-9-96

Supervised by:

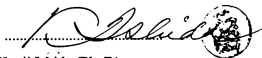

Kenji Ishida (Ph. D)
Course Professor MET (E)
World Maritime University

Assessed by:



Dr Jerzy Listewnik
Associate Professor
Higher Merchant Marine Academy
Szczecin, Poland.
Visiting Professor, World Maritime University

Co-assessed by:



Professor Takashi Nakamura
Maritime Technical College
Ministry of Transport, Japan.

ACKNOWLEDGEMENT

First and foremost, I would like to express my esteem and profound respect to Professor Kenji Ishida, for his support and concrete guidance in the preparation of this dissertation. I am also greatly indebted to Professor Peter Muirhead and Lecturer Mark Swanson for their kindness and openness during the course. My sincere thanks and profound gratitude to Dr. Jerzy Listewnik and MAN B&W Diesel A/S, Denmark, who gave me tremendous support in the writing of this paper.

I am extremely grateful to the Bangladesh Shipping Corporation (BSC) for nominating me to study at WMU and the Sasakawa Peace Foundation of Japan for providing me with a fellowship.

The encouragement and constructive criticisms received from visiting and resident professors and staff of the World Maritime University is greatly acknowledged.

I wish also to thank all the officials of MET institutions and organisations in Japan, Sweden, Norway, Denmark, Germany, Poland, United Kingdom and France who provided me with valuable information and experience during the field studies, I made throughout my study at WMU.

My heartiest thanks to my wife Shikha Rani Saha and sons Mithun and Shantonu for their endless love and support.

Heartfelt thanks are due to my mother for showering me with her endless love.

Finally, I would like to dedicate this paper to my late father, may his soul rest in eternal peace.

ABSTRACT

Title of Dissertation: The Technical and Economical Aspects of Marine Engine Selection

Degree: MSc

This study is based on a description regarding the development of the marine diesel engine; machinery design principles, technical and economical comparisons and finally the selection procedure taking into consideration operational behaviour and environmental aspects. The project can give guidance to shipowners/shipyards for the proper selection of a marine diesel engine and it can also serve as a guide for marine engineers and technicians on board ship.

The dissertation is a study of the selection procedure of marine diesel engine, which is both economically competitive and technically appropriate in terms of reliability, simplicity, durability and environmental aspects.

A brief look is taken at the history of the marine diesel engine and achievements due to the development of marine propulsion plants in the recent years. The thermal efficiency of marine diesel engines has increased to well over 50%, as have reliability and durability been improved. Effort has been made for all the possibilities of utilising the waste heat from the marine diesel engines.

The operational behaviour i.e. the vibration & noise effects and environmental aspects have also been enhanced. Hence, the marine engine selection programme is a comprehensive and complicated task.

The economical comparison among the four alternatives in Chapter 4 shows that, the MAN B&W 5S60MC two stroke slow speed engine, choosing the power take-off (PTO) with turbo-compound system (TCS) is the best choice for the selected Bulk Carrier, because of a high degree of reliability, low capital and maintenance costs, short pay back period and considerable amount of the net present value (NPV).

TABLE OF CONTENTS

Declaration	ii
Acknowledgements	iii
Abstract	iv
Table of Contents	v
List of Tables	viii
List of Figures	ix
List of Abbreviations	xi
1 Introduction	1
2 Development of marine diesel engines	
2.1 The history of marine diesel engines	5
2.2 Ship and machinery arrangements	6
2.2.1 Machinery space with diesel engine	7
2.3 The demand of diesel engines	9
2.4.1 Types of diesel engines	
2.4.2 The main differences between the slow speed and medium speed diesel engines	11
2.5 The development of marine diesel engines in 1990's	12
2.5.1 New development in reliability	13
2.6 Waste heat recovery system	16
2.6.1 Exhaust gas utilisation	16
2.6.2 Utilisation of scavenging air heat energy	19
2.6.3 Jacket cooling water heat energy	21
2.6.4 Summary of heat recovery system	22
2.7 Future development	22
3 Machinery design principles	
3.1 System engineering	24
3.2 Reliability aspects	28
3.3 Simplification	29
3.4 Economical aspects	30
3.4.1 Capital cost	30
3.4.2 Operational costs	31
3.4.3 Compound system	33
3.5 Operating behaviour	34
3.5.1 Vibration and noise	34
3.5.2 Heavy fuel capability	34

3.6	Environment concern	35
3.6.1	Proposed IMO Regulation 15 on Sulphur Oxides	36
4	Economical comparison	
4.1	Capital cost	38
4.2	Operating cost	38
4.3	Economical comparison I	40
4.3.1	Investment and operating cost	40
4.3.2	CMCR & RPM of four different kind of engines based on four alternatives assumed	43
4.3.3	Correction of the rate of interest	44
4.4	Economical comparison II	50
4.5	Economical comparison III; with/without shaft generator	51
4.6	Economical comparison IV	52
4.7	Conclusion of this chapter	53
5	Engine selection process	
5.1	Ship's power requirement	55
5.1.1	Propeller diameter & speed	56
5.2	Engine selection	57
5.3	Fuel saving	58
5.3.1	Optimising point	60
5.3.2	Fuel consumption at an arbitrary load	62
5.4	Engine room optimisation	63
5.4.1	Electricity production units	63
5.4.2	Power take off (PTO)	63
5.4.3	Controllable pitch propeller	64
5.4.4	Optimising the complete propulsion plant	64
5.4.5	Auxiliary units	64
6	Operation behaviours	
6.1	Vibration	67
6.1.1	External unbalanced moments	67
6.1.2	Guide force moments	69
6.1.3	Torsional vibrations	70
6.1.4	Axial vibration	72
6.2	Environmental aspects	72
6.2.1	Exhaust gas noise	73
6.2.2	Airborne noise	74
6.2.3	Structure-borne noise excitation	74
6.3	Exhaust gas emission control	76
7	Summary and Conclusions	78

Bibliography		81
Appendices		
Appendix 1	Several standard PTO systems	84
Appendix 2	Propeller equipment programme	86
Appendix 3	The new combustion chamber and cylinder liner	87
Appendix 4	Capital recovery factors	88

LIST OF TABLES

Table 4.1	Basic ship data	37
Table 4.2	Operating cost	39
Table 4.3.1	Assumed machinery costs	41
Table 4.3.2	Assumed machinery investment	42
Table 4.3.3	Fuel and lubricating oil prices	42
Table 4.3.4	Main Engine Alternatives	43
Table 4.3.5	SFOC of Engines & Fuel cost per year	43
Table 4.3.6	Assumed maintenance and spare parts cost for main engine	44
Table 4.3.7	Series Present Worth Factor	45
Table 4.3.8	Economical comparison I	46
Table 4.3.9	Cost of maintenance and spare parts	49
Table 4.3.10	Cost of lubricating oil consumption	49
Table 4.4.1	Economical comparison with & without TCS	50
Table 4.5.1	Economical comparison, Example III	51
Table 4.6.1	Economical comparison with diesel generator and 1 shaft generator with TCS/PTI and two diesel generator	52
Table 5.1	Conversion factors for adjustment of SFOC	60

LIST OF FIGURES

Figure 2.1	The total output of various engines from 1975 - 88	7
Figure 2.2	Slow-speed diesel machinery arrangement	8
Figure 2.3	Medium-speed diesel machinery arrangement	9
Figure 2.4	Relation between specific fuel consumption and power output	10
Figure 2.5	Piston/ring pack assembly MC vs MC-C	14
Figure 2.6	71.7 % available useful energy	17
Figure 2.7	Single pressure boiler turbo-generator system	19
Figure 2.8	Warm/hot water flow system-scavenge air heat recovery	20
Figure 2.9	Jacket cooling water heat energy recovery	21
Figure 3.1	Engine selection process on the basis of ship particulars	26
Figure 3.2	Speed and power curves calculated from ship particulars	27
Figure 3.3	Engine reliability	29
Figure 3.4	Development of the SFOC for diesel engines and development of the bunker price	32
Figure 3.5	Factors influencing overall fuel costs	32
Figure 3.6	Proposed IMO emission limits	35
Figure 4.1	Economical study of four different M/E alternatives	48
Figure 4.2	SFOC as per engine layout with/without TCS at CSR	49
Figure 5.1	Installed power for bulk carrier, tankers and general cargo ships	55
Figure 5.2	Engine power, propeller diameter and propeller speed for four-bladed propeller	56
Figure 5.3	Engine choice for a 46,800 dwt M. bulk carrier with 12,100 bhp at 100 rpm	58
Figure 5.4	Part load SFOC curves for the available engine versions	59

Figure 5.5	Engine load diagram	61
Figure 5.6	Specific fuel oil consumption at an Arbitrary load	62
Figure 6.1	1st order moment compensator	68
Figure 6.2	Power Related Unbalance (PRU)	70
Figure 6.3	ISO's NR curves and noise levels for a low speed diesel engine	75
Figure 6.4	Schematic layout of SCR system for a low speed diesel engine	76

LIST OF ABBREVIATIONS

BBC	Brown Brovery Corporation
BHP	Brake Horse Power
BSC	Bangladesh Shipping Corporation
CGS	Combined Shaft Generator
CMSR	Contracted Maximum Continuous Rating
CRF	Capital Recovery Factor
CSR	Continuous Service Rating
DG	Diesel Generator
EDR	Effective Discount Rate
HFO	Heavy Fuel Oil
ICS	Integrated Charged System
IMO	International Maritime Organisation
IRR	Internal Rate of Return
LO	Lubricating Oil
MCR	Maximum Continuous Rating
MDO	Marine Diesel Oil
NO _x	Nitrogen Oxides
NPV	Net Present Value
PTI	Power Take In
PTO	Power Take Off
Ro-Ro	Roll on Roll off
RPM	Revolution Per Minute
SFOC	Specific Fuel Oil Consumption
SO _x	Sulphur Oxides
SPWF	Series Present Worth Factor
TBO	Time Between Overhauls
TCS	Turbo Compound System

CHAPTER 1

Introduction

In the past thirty years, the marine diesel engine has become the most efficient propulsion plant for ships, through continuous development and technical innovations. Although it has superior competition for some types of propulsion, it can be used successfully in almost any application, and is generally considered to be the best in a wider range of marine applications than any other engine.

The specific fuel consumption of the diesel engine in most applications is lower than either steam or gas turbine and the fuel is usually at least as cheap per unit of heating value as theirs. Compared to the steam propulsion plant, the diesel also enjoys the advantages of internal combustion, which makes it compact, available in essentially a complete package, and simple to control.

There are various types of engines which are used as marine power propulsion. The shipowners have a choice for selection of engines for their ships to meet at short notice, the requirements as they emerged. The selection of an engine may be made as per type, size, and other technical & environmental requirements of the ship.

Before 1973, attention had been given to higher specific power per cylinder, high power-to-weight ratios and more power per unit cost, and since then the preoccupation has changed with fuel consumption.

The two most important factors in overall marine plant efficiency are fuel consumption and the thermal efficiency. Today's updated engines already achieved both of them but, equally as important is the need to modify existing installations.

Following the 1973-74 oil crises, comprehensive efforts were made by all diesel engines builders to reduce the specific fuel oil consumption of diesel engines.

For the diesel engines remarkable improvements have been achieved in the last fifteen years to reduce the specific fuel oil consumption. About a 25% reduction of fuel consumption has been reached and a total overall efficiency of over 50% has now been accomplished. Much improvement has been done by utilising waste heat for heating and electrical generation. Also by using a more economic way of operating machinery, and a better use of waste heat.

In large, two-stroke slow speed diesel engines the increases in stroke/bore ratio and brake mean effective pressure, the adoption of constant pressure turbocharging and uniflow scavenge, have characterised the period from the mid-seventies to date. It has appeared that by the mid-nineties increased witness advances in microprocessor-base regulation of engine elements such as fuel injector pump mechanisms or exhaust valve drives have taken place. In such arrangements, the various engine actuators will no longer be contained by mechanical linkage to the engine to ensure a secure and repeatable functions.

Nowadays the two-stroke slow speed engine is dominant in the area of propulsion machinery for merchant ships. The statistics of the installed power on board ships above 2000 dwt is approximately 75%. In small sized and specialized ships, the medium speed engines have covered the largest proportion in main propulsion plants.

Finally, the shipowners have to select an optimum marine diesel engine for their ships by considering the vital technical and economical aspects:

1. Capital cost
2. Operating cost:
 - manning (crews)
 - fuel oil consumption
 - lubricating oil consumption
 - maintenance
3. Choice of speed/flexibility

4. Reliability
5. Durability
6. Environment aspects.

Towards this end, an attempt will be made in this study to discuss **“The Technical and Economical Aspects of Marine Engine Selection”**.

This study has been prepared using a descriptive method obtained by reference to books, lecture handouts, periodicals, various reports, publications on marine diesel engines, conference and seminar papers.

Chapter 1 is a general introduction into the subject. It includes the previous and present situation of the marine diesel engine and the necessity of the diesel engine as main propulsion power.

Chapter 2 gives a brief description of the history of the marine diesel engine. The machinery arrangement, the demand of marine diesel engine in comparison with steam turbine and the development of marine diesel engines, especially with particular reference to all possible methods of utilizing waste heat from marine engine.

The machinery concepts for the new type of marine diesel engine has been dealt with in Chapter 3. The main goal, is the overall economy, which includes the following factors:

- reliability
- simplicity
- economy
- operational flexibility
- operational behaviour

The ship's propulsion power selection is a comprehensive and difficult task. Hence, before selection of an engine as a propulsion power for a ship, a technical study is obviously needed as well as an economical comparison. In Chapter 4 the economical comparison has been made by considering four different alternatives on equal terms, such as same propeller diameter, speed and propulsive efficiency.

The selection of a marine engine is dependent upon many factors, such as power/speed matching, propeller diameter and speed, economic ratings (low SFOC), engine room optimisation and degree of automation. In most cases, the shipowners like selecting the marine engines depend on man-power, experience, and short term targets. Therefore, in Chapter 5 the engine selection process has been discussed.

The operation behaviours of marine diesel engines include vibration, noise and the environmental aspects. The noise and exhaust gas emission control, especially new Regulation on limits of harmful exhaust gas emission should also be considered in engine selection. These important aspects will be included in Chapter 6.

Chapter 7 concludes the technical and economical aspects of marine engine selection that have been mentioned in the previous chapters.

CHAPTER 2

Development of Diesel Engines

2. 1. The History of Marine Diesel Engines

The history of the marine diesel engines is very young when compared with the history of shipbuilding. The diesel engine was developed in 1900, after Dr. Rudolf Diesel formulated his original engine cycle concept, as set out in his 1892 paper "Theory and construction of a rational heat engine", he envisaged a prime mover of unprecedented efficiency. For this he saw the need for high cycle temperatures, achieved by very high firing pressures, a thermo-dynamic relationship which is equally valid today.

There were very serious difficulties to be overcome with the diesel engines, development proceeded slowly, and it was not until 1903, when the first diesel engine (horizontal opposed-piston) of a 25 bhp, 210 mm bore and 300 mm stroke, was built by Dyckhoff for the French canal barge, "Petite Pierre" (Brown D: 1985)

The first Sulzer marine diesel engine was a 40 bhp two-cylinder four stroke unit of 260 mm bore and 450 mm stroke installed in the Lake Geneva cargo vessel "Venoge". Once this had been achieved, however rapid progress was made, and in a few years many firms in continental Europe were actively building diesels with as much as 500 HP per cylinder (Brown D: 1985).

The first B&W Diesel Engine was built in 1904. Then the first submarine diesels to enter service were four 300 bhp MAN four-cylinder four-stroke engines, of 330 mm bore by 360 mm stroke, delivered in 1907 for the two French submarines

“Circe” and “Calypso”. The diesel engine was invented while the steam turbine was quickly advancing. The steam reciprocating engine was in decline.

The diesel engine was able to enter the marine field at that time due to its higher efficiency, low fuel consumption, and the smaller space occupied due to the absence of a boiler. In 1912 the world’s first ocean-going diesel motor ship “Selandia” was launched by “Burmeister and Wain”. After that the marine diesel engines were greatly developed for use in the German submarines. The challenges to the coal-fired low pressure reciprocating steam engine came from the steam turbine and the diesel engine about the same time at the turn of the century. World war I retracted developments, however, and maintained the supremacy of coal for a little while longer. After the war oil found preference either as diesel engine fuel or for raising steam. It also reduced crew requirements and fuel storage was an easier task. After the Second World War the experience and confidence gained with diesel engines caused the demand of the marine diesel engine to increase rapidly.

The development of diesel engines continued, and till now. Fig. 2. 1 shows the total output of various engines from 1975 - 88.

2. 2 Ship and machinery arrangements

The various factors of marine machines all relate to its operation in a safe, reliable, efficient and economic manner. The main propulsion machinery installation will influence the machinery layout. This will determine the operational and maintenance requirements of the ship and the significance of engine selection.

Basically, ship’s propulsion means that a certain power needs to be transmitted from a piece of machinery, via a propelling device, to the water. With marine diesel engine this can be done in several ways, e. g. one engine direct-coupled to a propeller, one engine coupled via a gear to a propeller or multi-engine plant coupled via gears to one or more propellers. In this study only the first two will be discussed.

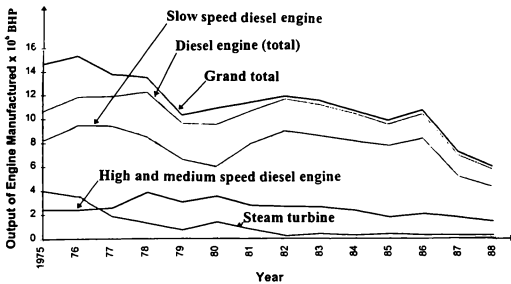

Fig. 2. 1 The total output of various engines from 1975 – 88.

Source: J. Listewnik (1995) and Al-Batati (1990)

2. 2. 1 Machinery space with diesel engine

Three principal types of machinery installation are to be found at sea today. Their individual merits change with technological advances and improvements and economic factors such as the change in oil prices. It is intended therefore only to describe the layouts from an engineering point of view: the direct-coupled slow-speed diesel engines, medium-speed diesels with a gearbox, and the steam turbine with a gearbox drive to the propeller.

Generally the machinery installation is of a compact and complicated nature. The main two items are the main engine and the boiler.

The more usual plan and elevation drawings of a typical slow and medium-speed diesel installation are shown in Figs. 2. 2 & 2. 3 respectively. An auxiliary boiler and an exhaust gas heat exchanger would be located in the uptake region leading to the funnel.

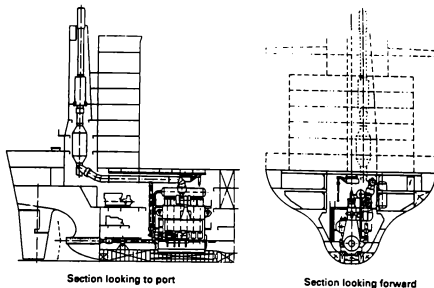

Fig. 2. 2 Slow-speed diesel machinery arrangement

Source: D. A Taylor (1990)

Analysis of ship and machinery arrangements

The goal of shipping is transportation of cargo from one place to another safely. From this point of view of propulsion, the utmost requirements for engines are efficiency, operational preparedness, safety, reliability and systemisation.

From the architectural side, in most ship design configuration an intensive effort is made to minimise the machinery required for the machinery space is considered to be deducted from that which can be used for other purposes (e.g. carrying cargo), and a maximum effort is accordingly made to restrain the dimension of the machinery space. Minimum space requirements are almost impossible to generalise satisfactory for different types of power plants. There is no substitute for making at least a preliminary ship arrangement layout to determine the effect of the power plant on the overall machinery space configuration.

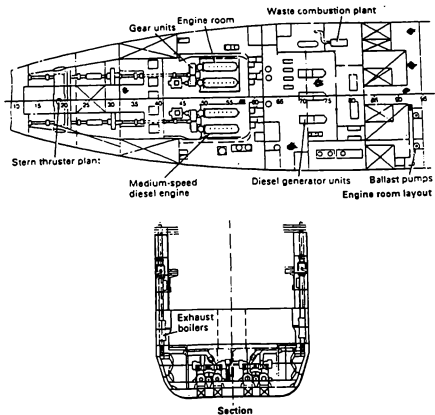

Fig. 2. 3 Medium-speed diesel machinery arrangement

Source: D A Taylor (1990)

2. 3 The demand of diesel engines.

A target has been made by all diesel engine-makers to catch-up with the modern requirements (e.g. Reliability, simplicity, cost-effectiveness, comfort, environment etc.) of marine engines for the new generation of ship, also a Statistics have shown that most of the engine-makers have been making a series of technological improvements, and the diesel engine demand is kept high level. In the Fig. 2.1 it can be seen that diesel engines have already covered all the merchant ships demand, except ships which are still driven by steam turbines.

The relation between specific fuel consumption and power output is shown in

Fig. 2. 4, where it is observed that the specific fuel consumption in the case of marine diesel engine of medium and low speed are lower than a steam turbine of 16000 HP to 35000 HP. Also there is a tendency towards the reduction of engine output by reducing a vessel's speed for fuel saving reasons.

The demand for diesel engine is more than that of steam turbine due to the following advantages

- The higher thermal efficiency (above 50%) and lower specific fuel consumption.
- The lower specific weight of marine diesel engine plant than that of the steam turbine plant, (specially at the lower range).
- The low capital cost.
- The low operating cost.

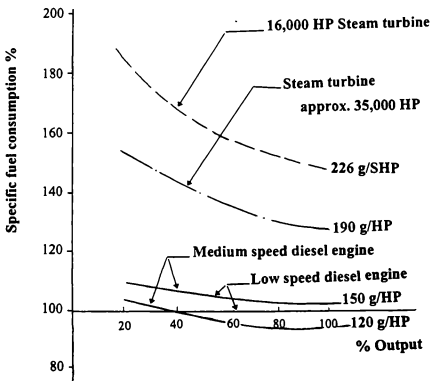

Fig. 2. 4 Relation between specific fuel consumption and power output

2. 4. 1 Types of diesel engines

i) The descriptive divisions

Diesel engines are divided into various types for descriptive purposes. The descriptive divisions include,

- (a) Cycle: Two-stroke & four-stroke engines.
- (b) Cooling: Air or liquid cooled engines.
- (c) Cylinder arrangement: In-line, v, w, or x.
- (d) Air supply: Naturally, aspirated, scavenged, or supercharged.
- (e) Starting means: High-pressure, hydraulic or electric motor.
- (f) Direction of rotation: Reversing or non-reversing.
- (g) Speed of rotation: High, medium and low speed engines.

ii) Engine speed classification

Engines are referred to as being high, medium or low speed. There is no clear line of demarcation between the classifications, but according to 'Harrington Roy L. (ed.) (1980) and Morton, Thomas Dunn (1978), they can be categorised as per following:

Engine	Shaft speed, rpm	power/output
1. Low speed	60 - 300	2000- 93,000 bhp
2. Medium speed	400 - 900	200 -47,500 bhp
3. High speed	1000 - 4000	up to 6,000 bhp

Considering the power transfer mode, output of engine, weight fuel consumption, cost involvement and maintenance considerations such as availability of spare parts low and medium speed diesel engines are used in marine power propulsion.

It was noted that the more usual prime mover are the slow-speed diesel engines directly coupled to the propeller shaft for bulk carrier, big tankers and other large size ships. But in some cases, considering the low capital cost, engine weight and overall dimension, easy maintenance, two or more medium speed diesel engines are coupled through clutch and couplings to a reduction gearbox to drive propellers.

Medium speed engines are mainly employed in specialised ships, i.e. for those ships in which a low headroom is required, in which a multi-engine propulsion system is needed to achieve a high degree of operational flexibility and redundancy, or in which a low machinery weight is of importance.

Such ships include: - Ferries, Cruise ships, Ro - Ro vessels, Ice - going ships, Trawlers etc.

2. 4. 2 The main differences between the slow-speed and medium-speed diesel engines

The major difference between slow-speed and medium speed engines is that the slow speed engines are directly connected to the propeller shaft, where the speed is very low and is suitable to the required revolution of the propeller. In the case of medium-speed engines where the speed is higher than that of the required revolution for the propeller, a reduction gear 3 to 4 reduction ratio is provided between the propeller shaft and engine. As a result the gear losses occur in that case.

The slow-speed engines are simple in construction. They are mainly of the cross-head engines in-line, while the medium-speed engines are of trunk piston, in-line or v-type.

Presently, medium-speed diesel engines can burn the same heavy fuel as that used for slow-speed marine diesel engines. The specific fuel consumption of slow speed engine is less than that of the medium-speed engines.

Lubricating oil consumption of slow-speed engines is lower than that of the medium-speed engines.

Slow-speed engines have long life time, which means longer economical life than medium speed engines.

2. 5 The Development of Marine Diesel Engines in the 1990's.

The demand of two-stroke slow-speed marine diesel engines has increased remarkably in the last decade. Therefore, development of such engines must be focused on product refinement and adaptation, both with a view to comply with altered operating conditions and production facilities and to meet requirements raised by changing trade patterns.

The development of marine diesel engines is progressing every day. Most of all the engine-makers have the goal of the refinement of diesel engines technology to meet the contemporary and future requirements of ship operators.

The two large market holders of marine diesel engine makers MAN B&W with their MC-engines and New Sulzer Diesel, with their RTA engine series taking development programme in every year. This section focuses on the MAN B&W engine programme.

2. 5. 1 New development in reliability

These two engine manufacturers have modified the following four major components for gaining higher reliability and heat efficiency.

1) Piston

The developed MC-pistons are of oil cooled piston crown, which is made of heat-resistant chrome-molybdenum steel, rigidly bolted to the piston rod to allow distortion-free transmission of the firing pressure.

The piston has four ring grooves which are hard chrome plated on both the upper and lower surfaces of the grooves.

A cast iron piston skirt is bolted to the underside of the piston crown. It is shown in Fig. 2. 5

The significant difference between the new and old type of pistons are:

- Locking method for screws and nuts modified
- Piston skirt modified for mounting with flange screws
- Bronze band in piston skirt introduced for improving running in condition.

With the modification of the above the new type piston has following advantages:

- Increasing firing pressures
- It is oil cooled - the advantage of eliminating any accident from corrosion and mixing of cooling media.
- The utter simplicity of piston crown gives low production costs.
- Low failure rate

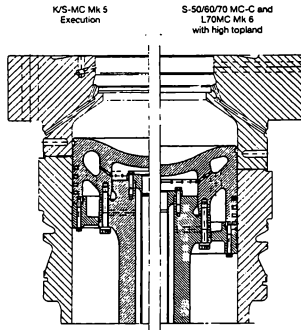

Fig. 2. 5 Piston / ring pack assembly MC vs MC-C

Source: MAN B&W Catalogue (1996)

2) The new combustion chamber and cylinder liner

The most noticeable improvements introduced in conjunction with the present ratings are centred around the combustion chamber. The new combustion chamber configuration, features a sturdier cylinder liner with a bore cooled upper part and with increased thickness. The liner has been made shorter and the cylinder cover correspondingly deeper, which means that more of the combustion space is now surrounded by heat resistant steel which is better able to absorb the higher heat flux associated with the present ratings. (See Appendix 3).

3) Exhaust valve & valve housing

Nimonic exhaust valves are used in MC engines. To ensure extended service life of the exhaust valve, Nimonic valve spindles and hardened steel bottom pieces are standard on the large bore engines. The exhaust valve housing is made with an increased wall thickness so as to raise the surface temperature and thus reduce the risk of cold corrosion. In addition, the damped closing of the exhaust valve has been introduced to ensure softer landing of the spindle on the seat, thus preventing valve knocking, and ensuring a longer life time of the seats.

4) Fuel pump

The fuel pumps for the larger engines incorporate variable injection timing for optimising the fuel economy at part load, the start of the fuel injection being controlled by altering the pump barrel position by means of a toothed rack and a servo unit. Individual adjustment can be made on each cylinder and, furthermore, collective adjustment of the maximum pressure level of the engine can be carried out to compensate for varying fuel qualities, wear, etc.

Both adjustments can be carried out while the engine is running. The fuel oil pump is furnished with a puncture valve, which prevents fuel injection during normal stopping and shutdown.

2. 6 Waste heat recovery system

2. 6. 1 Exhaust gas utilisation

The exhaust gas heat energy is the most attractive heat energy source to be utilised for auxiliary use due to the amount and the relative high temperature level.

The normal mode of conversion of the exhaust gas heat energy to useful energy is by means of a steam plant in which the waste heat energy is used to vaporise water in a boiler.

In practice, when heat energy is taken from gas or any other fluid, the temperature falls from an initial value T_H at the heat exchanger inlet to a final value T_L at the outlet. The heat energy transferred per unit mass of gas will be

$$Q_T = C_p (T_H - T_L) \text{ ----- (1)}$$

Where C_p is a heat transfer coefficient of gas

The total work obtainable with an ideal cycle with a surrounding temperature of T_O is $Q_{MAX} = C_p (T_H - T_H - T_O \ln T_H / T_L)$ ----- (2)

Dividing equation (2) by equation (1), the maximum possible thermal efficiency of the heat energy recovery becomes,

$$\eta_r = 1 - T_O / T_H - T_L \ln T_H / T_L \text{ ----- (3)}$$

Thus, a high degree of utilisation of the exhaust gas heat energy requires an exhaust gas outlet temperature as low as possible.

Every attempt has taken to utilise energy in waste heat and recovery from exhaust gas and coolant is established practice. Sufficient heat energy potential is normally available in exhaust gas at full engine power to supply total electrical and heating services for the ship. The amount of heat actually recovered from the exhaust gases

depends upon various factors such as steam pressure, temperature and evaporative rate required; exhaust gas inlet temperature, mass flow of gas, condition of heating surfaces, etc. Waste heat boilers can recover up to 56% of the losses to atmosphere in exhaust gases. From jacket water temperature and scavenge air are used for heating water and heat recovery 3.1% and 4.6% respectively. It is shown in Fig. 2. 6.

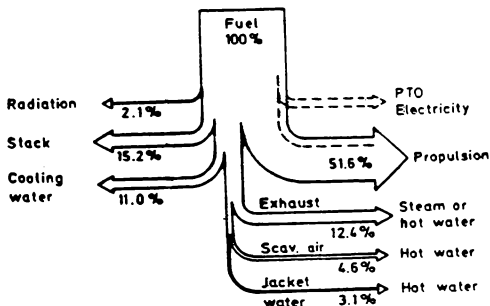

Fig. 2. 6 71.7% Available useful energy

Source: J. Listewnik (1995)

(1) Boiler and turbo-generator system

The main type of exhaust gas boilers and steam/condensate systems may be divided into two categories, one for low and one for high degree of heat utilisation. A low utilisation system based on the exhaust gas heat will normally only supply saturated steam for heating services, where a high utilisation system also incorporates the production of superheated steam for a turbo-generator.

In both cases the obtainable steam production depends on the following parameters:

- Exhaust temperature before exhaust gas boiler
- Lower limit of exhaust temperature
- Exhaust gas amount
- Steam pressure
- Exhaust gas boiler system.

When the exhaust gas boiler steam production is used to drive a turbo-generator, the additional factors will influence the electric power production,

- Superheated steam temperature
- Condenser pressure
- Turbine efficiency

If the heating service requirements, are smaller than what can be produced by utilising the available exhaust gas temperature, then electric energy production may be a viable alternative.

Due to simplicity and low cost, the single pressure system is most common in high utilisation boiler turbo-generator systems. An example of such a system is shown in Fig 2. 7. The system is fitted with a regenerative feed water heat exchanger. The economiser is integrated with the evaporator and hence the circulation amount of about four times the feed water flow, circulates through the economiser and evaporator. The large circulation through the economiser increases the heat transfer.

(2) Turbo compound system

Over the recent years the efficiency of turbochargers has increased. These high efficiency turbochargers available today makes it possible to extract more energy from the exhaust gases than needed for an ample air supply to the engines. This have introduced solutions with a turbo-compound system where the extra power is introduced to the engine shaft by Brown Brovery Corporation (BBC)

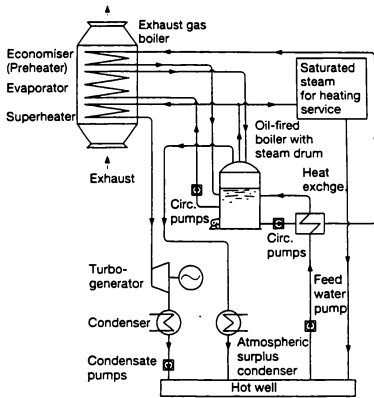

Fig. 2. 7 Single pressure boiler turbo-generator system

Source: Engja, Hallvard (1989)

2. 6. 2 Utilisation of scavenging air heat energy

Due to relative the high temperature of the scavenging air heat energy makes it an attractive heat source. The temperature drops rapidly at part load on the engine and thus available heat energy.

One requirement which must be met in order to utilise the temperature level is that the air cooler has two or more sections, so that parts of the heat energy can be

utilised at a high temperature level in addition to other sections which can bring the scavenging air temperature down to an acceptable level. Heat energy recovery will then only be possible in the first section of the air cooler. The systems alternatives are shown in Fig. 2. 8, are in use,

- Scavenging air high temperature section is connected to jacket cooling water system.
- Scavenging air high temperature section is connected to a separate recovery-circulation system.

The first system alternative is mostly used for medium speed engines. This is partly due to generally higher cooling water temperatures for these engines compared to slow-speed engines, and that scavenging air heat energy is a smaller proportion of the total heat loss.

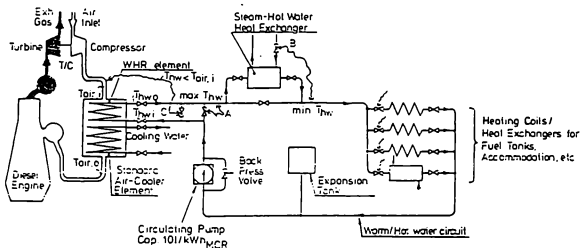

Fig. 2. 8 Warm/hot water flow system - scavenge air heat recovery

Source: Engja, Hallvard (1989)

System with separate recovery-circulation is mostly used for slow-speed engines. The relative low cooling water temperature used for these engines makes a combined waste heat energy utilisation less attractive due to smaller energy recovery, and will require a large heat transfer area.

2. 6. 3 Jacket cooling water heat energy

As shown in Fig. 2. 6 the jacket cooling water heat energy 3.1% of the heat energy supplied to the engine which amounts to 6-7% of the engine power. The common utilisation of this heat energy is through a separate waste heat circulation system in order to avoid contamination of the cooling water. Fig. 2. 9 shows an example of a system for jacket cooling water utilisation.

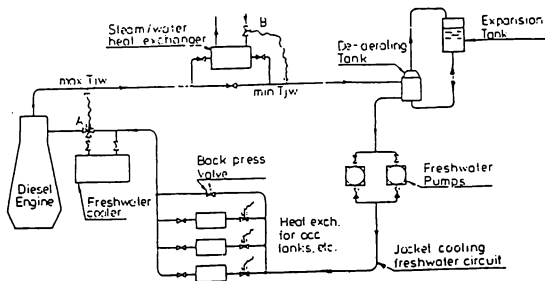

Fig. 2. 9 Jacket cooling water heat energy recovery

Source: Engja, Hallvard (1989)

2. 6. 4 Summary of heat recovery system

About half of the energy supplied to the main engines in ships is what has been named waste heat. Competitive pressure on shipping and the increasing fuel crisis created an increasing need to utilise this waste energy for useful purposes. In the last few years many sophisticated solutions have been proposed to maximise utilization.

The choice of a power recovery system depends on many factors. Dominating all is the life-cycle cost of the entire machinery installation. When all factors are considered it is not always the complicated system that is sophisticated. Money is the deciding factor

2. 7 Future development

Because of the outspoken desire in the market for further improved and securing more reliability of marine diesel, all engine manufacturers have adopted a long term programme with the aim of developing the necessary systems and components so as to produce a future engine generation with greater flexibility in terms of operating modes, and with the highest degree of reliability.

To meet the reliability target, a condition monitoring system will be used to evaluate the general engine condition so as to maintain engine performance and keep its operating parameters within the prescribed limits.

Another intention to further develop systems for detecting severe faults such as piston ring blow-by, cylinder liner scuffing, abnormal combustion, etc.

To meet the operational flexibility target, electronically controlled systems for operating the fuel injection and exhaust valve systems may be applied, possibly also including control of the turbocharger system. The control system will contain data or optimum operation in a number of different modes, such as "Fuel Economy Mode", "Emission Control Mode", & "Reversing/Crash Stop Mode".

Both the exhaust valve system and the fuel injection system could be operated without a conventional camshaft, but controlled by means of a hydraulic/electronic system. Whereas the need for controlling the exhaust valve operation is limited to control of the timing for opening and closing the valve, the control system will be simpler than for the fuel injection system, where several parameters can be varied.

The cylinder lubrication system is controllable from the condition evaluation system so that the lubricating oil amount can be controlled in accordance with the engine bed, with increased lubrication in connection with load changes, and with increased lubricating oil doses in the event of scuffing and blow-by indications. Such systems are already available for existing engines.

The turbocharging system may incorporate control of the scavange air pressure when using a turbocharger with variable turbine nozzle geometry, control of by-pass valves, turbocompound system valves and turbocharger cut-off valves.

The operating modes may be selected from the bridge control system or by the system's own control system. The former case applies to the Fuel Economy Modes and the Emission Controlled Modes. The engine protection mode, in contrast, will be selected by the condition monitoring and evaluation system independent of the actual operating modes, when this is not considered to endanger the ship's safety.

The world is constantly changing, thus creating new challenges to the development of diesel engines, the marine diesel engines, developed in the days when the battle for promoting the reliability and reducing SFOC rated, have evolved into a highly reliable and very fuel-efficient engine with low spares consumption.

In view of the increasing costs of obtaining even lower SFOC for the engine itself, and the current modest level of fuel oil prices, future development will continue, besides concentrating on means to optimise total economy. Further items such as operational behaviour and environmental aspects will be discussed in subsequent chapters.

CHAPTER 3

Machinery Design Principles

The machinery design should be made by follow certain principles to meet the requirements in operations. It is clear that overall economical efficiency is the key point in machinery design, operation, maintenance, and comparisons.

Overall economical efficiency means:

- Reliability at sea, with durability and low maintenance.
- Low capital cost
- Low manning level
- High fuel economy.

Therefore, overall economical efficiency will be the main consideration for future propulsion plants.

3. 1. System Engineering

For a system engineer, whether working for a shipowner, a shiyard or an engine-maker, a good engine programme to propose for selection of an engine with a scope of offering a number of engine alternatives for easy installation and overall energy conservation.

There are several possibilities amongst the existing systems and engines, together with the inherent flexibility of the individual units in an engine programme provide the means for finding ideal solutions to virtually any conceivable specification requirement.

It is well known from statistical data that a two-stroke direct-coupled engine selection to a propulsion plant is the first choice and that such a selection is in fact, also the final choice except in such special cases where all two-stroke possibilities have been exhausted.

The first estimate on a suggested propulsion system will often have to be given on the basis of very preliminary physical data of a ship. The preliminary data for a certain ship and an outline of the engine selection process can be seen in Fig. 3. 1.

Fig. 3. 2. shows a calculated speed / power curve with corresponding propeller speed. When these characteristics are entered in the engine programme, a number of engine alternatives will be appeared. Estimations of ship's load profile, electricity and heating requirements will offer a further study to select the most economical engine / propulsion plant for the ship. Such system engineering analysis comprising of an economical analysis of the capital cost and the operating costs of a number of alternative engines electricity producing equipment has been introduced.

This is also the case for vibration aspects, which is an essential item analysed in the course of a project. An analysis of auxiliary equipment for the engine is also carried out.

In the course of analysis and preparatory system engineering for the entire engine room it is better to look into an evaluation of engines with and without turbo-compound system and with and without main engine driving generators.

As a result of such an analysis, many engines currently have been equipped with Power Take Off (PTO)/ Power Take In (PTI) systems. It is also not worthy that such systems as the Integrated Charged System (ICS), which allows an auxiliary engine to run under idling conditions using heavy fuel.

The system allows a practically 100% utilisation of a turbo-generators, without having a power turbine on the auxiliary engine thereby maintaining the full simplicity of the main engine, and still benefiting from the economies of turbo-compound system.

System engineering will be further developed and provides an increasingly important additional feature of the engine programme

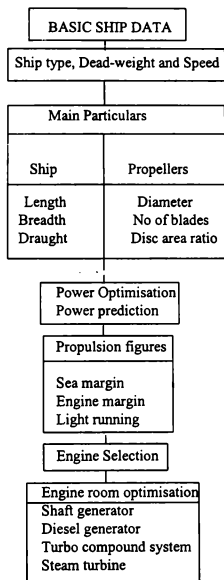
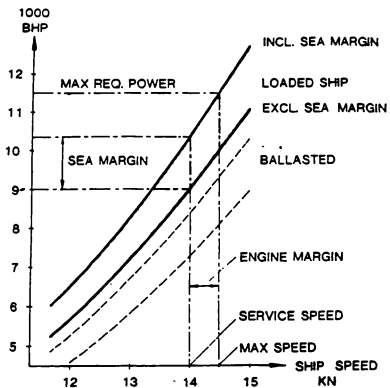

Fig. 3. 1 Engine selection process on the basis of ship particulars.

Source: Engine selection guide MAN B&W 3rd edition 1993.



Source: J. Listewnik (1995)

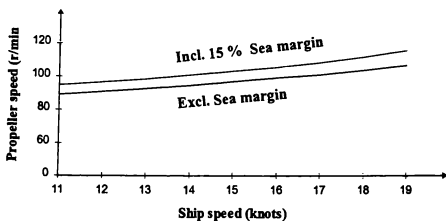

Fig. 3. 2 Speed and power curves calculated from ship particulars

3. 2 Reliability Aspects

In the selection of the most suitable type of machinery, reliability in service is one of the most important factors and should be given proper emphasis. The design effort devoted to this consideration has been receiving increasing emphasis during recent years. This has been attributed to the increasing complexity of the modern equipment and the increased reliability requirements, which are associated with the trend toward reduced manning. Breakdown in the propelling machinery may mean the loss of ship availability, which is very serious matter for the owners and operators. Considerations other than reliability, such as fuel economy, weight/space, and first cost, which may seem to be important in the early stages of design, later become surprisingly insignificant when compared with irritating and costly service interruptions which can result from inadequate reliability.

Evaluating the service and design margin is difficult; the type of fuels and the pressures, temperatures, and pressure ratios used in the design have a significant effect on the plant reliability. However realistic trade-off studies require that either the degree of conservatism be consistent between various candidate power plants or an allowance be made for the differences.

Influencing Factors

The reliability of a propulsion power plant is influenced by various factors; the most important factors are:

- Basic engine design.
- Working parameters
- Quality of manufacturing
- Quality of assembling
- Quality of maintenance
- Quality of operation

- Monitoring

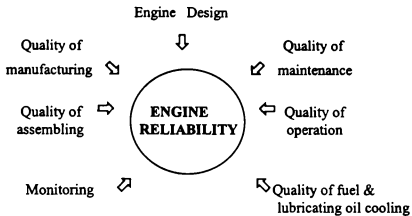

Fig. 3.3 Engine Reliability

Related standards and requirements about the reliability are:

- Extending the time between overhauls (TBO) up to 15,000 hours for the main components e. g. piston, exhaust valves.
- Keeping low wear rate, for example the liner & ring wear to 0.06mm /1000 hour and 0.4mm / 1000 hours respectively, and at the lowest possible lubricating oil consumption.
- Minimising the amount of intermediate maintenance for fuel nozzles and other components needing routine maintenance.
- Developing software and hardware certain for an efficient condition monitoring system.

3.3 Simplification

‘Simplicity is a quality. When quality ends genius gone’ - Prof. J. Listewnik (1995).

To the operators simplicity means that practically no damage is fatal. The internally accumulated energy that needs to be absorbed in a particular part of the

engine in case of a mechanical mishap is moderate due to the low speed, and the risk of consequential damage is therefore limited. In a design principle of the slow speed engine, a damaged engine can practically operate, for which reason low speed diesel engine installations are designed as single- engine installation with no "take-home" power. Therefore, a simple slow speed engine is invariably been chosen, where great reliability must be ensured under any circumstances.

3. 4 Economical Aspects

3. 4. 1 Capital cost

The most important task with respect to engine manufacturing today is the competitive commercial environment asking for still further reductions in manufacturing costs per unit power.

The engines of any manufacturer which are built by their licensees are in accordance with licensor's drawings and standards. In few cases, some local standards may be applied to facilitate production; however all spare parts are interchangeable with main manufacturer's designed parts.

Each large and small component is continuously surveyed before fitting so as to make it possible to adjust to present and new facilities, for production cost contract. By using production experience as well as service feed-back from previous engine designs in the design process, the number of production hours has been reduced by approximately 20% compared to previous engines (MAN B&W).

This is because, the number of components used for certain engine sections has been remarkably reduced, thereby achieving a reduction of production cost as well as assembling cost.

In addition to the engine manufacturing cost, the engine related installation costs, such as auxiliary power requirements, the cost of the fuel and lubricating oil

treatment plant, and cooling equipments are also taken into consideration. This means the cost of the whole propulsion plant.

3. 4. 2 Operational Costs

The operational cost comprises of the following:

- Manning (crew)
- Fuel oil consumption rate of engines.
- Lubricating oil consumption rate of engines.
- Maintenance cost (spare parts)

1. Fuel consumption rates of engines

Due to high fuel prices in the past (1980- 1985) engine development has been expanding with respect to finding ways of reducing the fuel consumption rates engines. Up to now the specific fuel consumption rate has been decreased by about 50% in last 20 years (shown in Fig. 3. 4).

At present fuel prices are comparatively low and they can without doubt be expected to remain so in the near future, fuel costs still take a share of 40% to 60% of the ship's running costs. So it can be said that high economic efficiency means first and foremost low fuel consumption rates. Therefore, Specific Fuel Oil Consumption (SFOC) is still the key point for engine manufacturers to pursue.

Fuel costs are related with following factors (shown in Fig. 3. 5).

- Power / speed selection
- Engine optimisation overload range;
- Recoverable waste heat;
- Auxiliary power need.

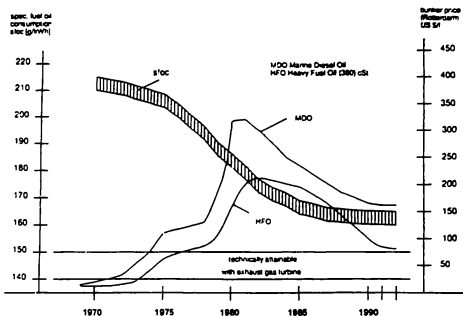

Fig. 3. 4 Development of the SFOC for Diesel Engines and Development of the Bunker Price

Source: 16 th Annual International Marine Propulsion Conference, 10-11 March, 1994.

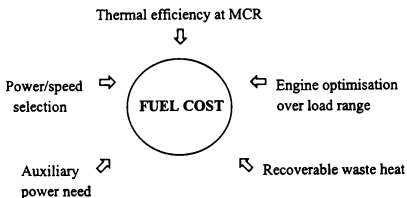

Fig. 3. 5 Factors influencing overall fuel costs

2) Lubricating oil consumption

Another important factor influencing the overall economic efficiency of a propulsion plant is the lubricating oil (LO) consumption rate. Usually the prices of LO is 8 times higher than Fuel Oil (FO)

Utilising modern techniques of engine design and advantage of lubricator, it significantly reduction in LO consumption rates have been achieved.

The Medium speed engines are of very low LO consumption rates, more over can have a corresponding contaminating effect on the system oil, which in some cases can make replacement of the oil charge.

3) Spare parts

Other important factor of operational cost is the price of spare parts. Nowadays considering longer service period by metallurgical technology development spare parts consumption costs are also reduced.

4) Manning

In the recent years the shipowners are meeting tough competition . This causes in an increasing desire to cut costs to improve a competitive position. A possible solution is only to reduce the crew number.

The trend towards a further reduction in manning levels will continue. Henceforth the reliability of engine must be further improved and the simplification of propulsion plants.

3. 4. 3 Compound system

Other than lowering specific fuel consumption on the diesel engine the propulsion system as a whole is now included in economic efficiency considerations.

Effective utilisation of waste heat from diesel engine plants offer an optimum measure of energy saving, such as exhaust gas boiler and economiser.

The turbo compound system has reduced specific fuel oil consumption by 5-7g/kWh. without making the propulsion system more complicated.

3.5 Operating behaviour

3.5.1 Vibration & noise

The two most important issues with respect to operating behaviour of a ship are vibration and noise.

The introduction of super-longstroke crosshead engines with a few cylinders, high combustion pressures and huge rotating and reciprocating masses made vibration a problem for ship designers.

Presently, in many passenger vessels direct resiliently mounted engines are being installed in order to keep disturbing engine vibrations away from the body of the ship, thus making life more comfortable for passengers and crews as regards the noise and vibration levels in the vessel.

3.5.2 Heavy fuel capability

It is well known that today's marine diesel engines are capable to burn low quality fuel oil, but engine builders must be well prepared for further deterioration in fuel quality. The selection will may cope with fuels that are more difficult to burn.

The bore-cooled piston with welded high temperature protection layer of Inconel-625 and the particular exhaust valve design combines to give the engines of recent years a unique capability for sufficient time between overhauls when burning low quality fuel oils

3.6 Environment concern

In the maritime field environment problems will come into focus more, and demands for the reduction in pollutant emissions will increase, especially for traffic on the coast and in port. This may lead for engines being developed with better combustion with catalysts of flue gas cleaning.

The health aspect will be taken into consideration in the design of fuel systems for an engine and will have an influence on marine engine selection

As proposed by IMO Regulation 14 on Nitrogen Oxides (NO_x), diesel engines with a power output of more than 100 kW which are installed on ships constructed on or after 1 January '98 need to comply with the emission of nitrogen oxides (calculated as the total weighted emission of NO_2) from the engine is within the following limits: (shown in Fig. 3.6).

- i) 17 g/kWh when rated engine speed (N) less than 130 rpm
- ii) $45 \times n^{-0.2}$ g/kWh when "N" is 130 or more but less than 2000 rpm
- iii) 9.84 g/kWh when "N" is 2000 rpm or more.

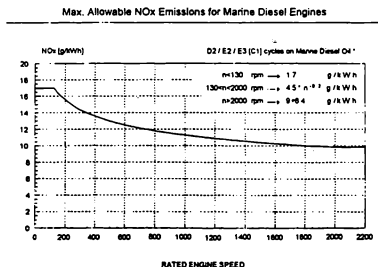

Fig. 3.6 Proposed IMO emission limits

Source: IMO, MEPC 38/9/10, (April, 1996)

3. 6. 1 Proposed IMO Regulation 15 on Sulphur Oxides (SO_x)

General Requirements

The sulphur content of any fuel oil used on board ships shall not exceed (5.0% m/m)

Special Requirement:

While ships are within special areas, at least one of the following conditions shall be fulfilled.

(a) The sulphur content of fuel oil used on board ships in a special area shall not exceed (1.5% m/m).

(b) An exhaust gas cleaning system approved by the Administration in accordance with the guideline developed by the organisation, shall be applied to reduce the total emission of sulphur oxides from ships, including both auxiliary and main propulsion engines, to (6.0 g SO_x / kWh) or less calculated as totalled weight emission of sulphur dioxide.

(c) Any other technological method that is verifiable and enforceable to limit SO_x emissions to a level equivalent to that described in paragraph (b) shall be applied. These methods shall be approved by the Administration.

CHAPTER 4

Economical Comparison

In these days the selection of a ship's propulsion power is a comprehensive and difficult task. Hence whenever a shipowner/shipyard decides to select a propulsion power for a ship it obviously needs to make a technical study as well as an economical comparison. This economical comparison should be made by taking different propulsion alternatives and on equal terms, such as propeller diameter, speed and propulsive efficiency.

Therefore, the comparison will be made on the basis of a standard ship a M. Bulk Carrier of 46,800 dwt and it would be assumed that the basic ship data are the same irrespective of the propulsion system chosen. The basic ship data is shown in table 4.1

Table 4.1 Basic Ship Data

M. Bulk Carrier	Parameters
Length	190.0 m
Breadth	31.54 m
Draught	11.65 m
Block Coefficient	0.8
Ship Speed	15.25 knots

Source: Lloyd's Register of Shipping, 1996

The comparison has been concentrated mainly on the basis of capital cost and the operating cost. The following factors have been taken into consideration for economical comparison.

- a) Capital cost
 - Propulsion power related capital investment
- b) Operating cost
 - Fuel oil
 - Lubricating oil
 - Spare parts
 - Maintenance cost

4. 1 Capital Cost

The capital investment for the power propulsion plant being dependent on place, time and engine builders/suppliers. The real differences in the capital costs of the engines are hidden in the ship price. Nevertheless, no economical study can neglect the capital and operating costs. Hence either the shipowner or the shipyard must carry out an economical study. Some elements of operating expenses must also be evaluated in relation to differences in capital investments.

Generally speaking when a choice is given between medium speed and low speed main engines, the traditional thinking of the shipowner will favour low speed engines in spite of lower initial cost of medium speed engines. That is why a technical and economical comparison between the alternatives should be carried out. Emphasis on costs and difference of revenue should be kept in mind.

4. 2 Operating Cost

A typical breakdown of operating cost is shown in table 4. 2.

Table 4.2 Operating Cost

1	Crew expenses	25%
2	Fuel & lubricating oil expenses	42%
3	Maintenance cost	15%
4	Fees/dues	15%
5	Other charges	3%
Total		100%

Source: C. R. Cushing (1996) and Butman (1996)

From the above table it is observed that the main power propulsion plant selection primarily affects the fuel/lubricating oil expenses and maintenance costs, i.e. 57% of the operating cost.

Crew Expenses

At the present time the degree of ship board automation and their nations of origin influence on crew expenses. However as the man-hours used for overhauling are to some degree of quantifiable, they are taken into account with the maintenance expenses.

Maintenance expenses

By experience it has been seen that the maintenance expenses for a medium speed engine are higher than for the equivalent low speed engine.

Marine propulsion power plants, whatever types they are, have to fulfil the following conditions:

-Number of crew and man-hours needed for operation and maintenance of the power plant should be minimum.

Generally it is considered that the overhauling of the engine components is expensive due to the greater number of cylinders in the case of a medium speed engines are installed as propulsion power.

Lubricating Oil Consumption

Presently the medium speed and low speed engines have almost the same specific lubricating oil consumption.

Fuel Oil Consumption

Now-a-days the medium speed diesel engines are capable of burning the heavy fuel oil but with some particular difficulties in maintenance and lubricating consumption. Most of the medium speed engines use heavy fuel oil with lower viscosity, whereas the low speed engines usually use heavy fuel oil with higher viscosity's. Now the medium and low speed engines have almost the same specific fuel oil consumption (SFOC).

4.3 Economical Comparison I

The economical comparison has been made here on the basis of economical aspect, of four different types of engines. Three of them are two stroke slow speed engines and the 4th one is a four-stroke medium speed engine.

4.3.1 Investment and Operating Cost

With regard to investment and operating costs, the following items are assumed;

1. Contracted maximum continuous rating (CMCR) for all the engines is equal to 10,000 kW.

2. Machinery prices are based on an average cost/kW and not on quoted prices by manufacturers and the prices are for comparison only.
3. The continuous service rating (CSR) is fixed at 80% of maximum continuous rating (MCR).
4. The ship is a M. Bulk Carrier.
5. When the prices are used for an economic comparison, all assumption have to be made on an equal term basis. Therefore, prices are based on those for engines manufactured in European countries at the beginning of 1990's.
6. Maintenance costs are average maintenance costs per kW power in European countries.
7. Fuel oil and lubricating oil prices are based on the prices of May 1996.
8. The intention of this study is to explain the economic comparison.
9. Sailing days of the ship is 250 days in a year.
10. The interest rates 8% (see Table 4. 3. 7)
11. The inflation rates 3% (see Table 4. 3. 7)
12. Required life time 15 years.

The following Tables 4.3.1 to 4.3.3 are the basic cost data for economical comparison.

Table 4. 3. 1 Assumed Machinery Costs

Type of Machinery	US\$/kW
Two stroke low speed engine	355
Four stroke medium speed engine	265
Diesel generator (MDO)	205
Diesel generator (HFO)	280
Shaft generator with CGS	355

Source: Average price of different engine makers e.g. MAN B&W Diesel A/S, Alpha Diesel, Denmark and SEMT Peilstick, France.

Table 4. 3. 2 Assumed Machinery Investment

Machinery type	Power kW	Assumed investment US\$**
5S60MC MAN B&W	10,200	3,621,000
5RTA 62U New Sulzer Diesel	11,000	3,905,000
6L60MC MAN B&W	11,520	4,089,600
8PC-40 SEMT Pielstick	10,600	2,809,000
Shaft generator with CGS	500	264,000
TCS/PTI	—	150,000
PTO/PTI	—	415,000
Diesel generator (MDO)	500	102,500
Diesel generator (HFO)	500	138,000
Coupling/clutch and reduction gear etc.	—	230,000

** The prices are assumed from the manufacturers recommendations.

Table 4. 3. 3 Fuel and lub. oil prices

Fuel/Lub. oil type	Cost US\$/Tonne
Heavy fuel oil 380 CST 50°C	108
Heavy fuel oil 180 CST 50°C	112
Marine diesel oil	190
Lub. oil	1010

Source: The Llyod's List May 1996

4. 3. 2 CMCR & RPM of four different kind of engines based on four alternatives assumed:

Table 4. 3. 4 Main Engine Alternatives

Engines type	MCR kW	CMCR kW	MCR- RPM	CMCR- RPM	CMCR (%)	RPM (%)
5S60MC	10,200	10,000	105	100	98%	95%
5RTA 62U	11,000	10,000	113	100	91%	88.5%
6L60MC	11,520	10,000	123	100	87%	81%
8PC-40	10,600	10,000	375	100	94%	100%

As per engines layout SFOC & fuel cost per year are shown in Table 4. 3. 5 Fuel cost calculation has been made taking correction factor 1.05 for the difference in lower calorific value between MDO and HFO.

Medium speed engine used heavy fuel oil of low viscosity i.e. 180 CST. 250 sailing days assumed in a year.

Table 4. 3. 5 SFOC of Engines & Fuel Cost per year

Engines type	CMCR kW	SFOC g/kWh.	Fuel Cost US\$/year
5S60MC MAN B&W	10,000	170.0	1,156,680*
5RTA 62U Sulzer Diesel	10,000	159.0	1,087,836
6L60MC MAN B&W	10,000	171.0	1,163,484
8PC-40 SEMT Pielstick	10,000	172.7	1,218,571

* Method of calculation:

$$10,000 \times (170/10^6) \times 24 \times 250 \times 1.05 \times 10^8 = \text{US\$}1,156,680.$$

Table 4. 3. 6 Assumed Maintenance and Spare parts costs for M/E alternatives

Type of Machinery	Specified MCR Power kW	Specific Maint. Cost US\$/year	Total Maint. Cost US\$/year
5S60MC	10,200	9.12	93,024
5RTA 62U	11,000	9.12	100,320
6L60MC	11,520	9.12	105,062
8PC-40	10,600	11.05	117,130

4. 3. 3 Correction of the rate of interest

For an economical study of different alternatives of marine diesel engines the following calculation for correction of interest rate is should be carried out for 15 years. The calculation done here as per method of I. L. Buxton (1987), which is most relevant for the economical evaluation of maritime industry.

Rate of inflation (e) = 3.0%

Rate of interest (i) = 8.0%

Required life time (n) = 15 years

The effective discount rate (EDR) = (r) can be calculated by using the equation,

$$(1+r) = \frac{1+i}{1+e} = \frac{1+0.08}{1+0.03} = 1.0485$$

Then, $(1+r) = 1.0485 \therefore r = 1.0485 - 1 = 0.0485$ or 4.85%

The Series Present Worth Factor (SPWF) is obtained by using the following formula,

$$SPWF = \frac{(1+r)^n - 1}{r(1+r)^n} = \frac{(1+0.0485)^{15} - 1}{0.0485(1+0.0485)^{15}} = 10.48$$

The Series Present Worth Factors (SPWF) at different inflation rates and different rates of interest are shown in Table 4. 3. 7.

Table 4. 3. 7 Series Present Worth Factor (SPWF)

Inflation	2 %			3 %			5 %		
	5 %	8 %	10 %	5 %	8 %	10 %	5 %	8 %	10 %
EDR (r)	0.029	0.059	0.078	0.019	0.048	0.068	0	0.029	0.047
SPWF	11.99	9.79	8.64	12.91	10.48	9.22	0	12.06	10.55

The Capital Recovery Factor (CRF), the ratio between uniform savings per year and the difference of capital investment is calculated by the following process:

$$\text{CRF} = \frac{\text{Savings per year}}{\text{Difference of capital investment}}$$

$$\text{Simple pay back period} = \frac{1}{\text{CRF}}$$

Payback Period:

Payback period is the number of years, which takes the net revenue to accumulate to the level where it equals the investment. The payback period can be found by using the calculated CRF and a given rate of discount $r = 4.85\%$ as per table 7 of I. L. Buxton (1987). (See Appendix 4)

Net Present Value (NPV):

$$\text{NPV} = (\text{SPWF} \times \text{Savings per year}) - (\text{difference of investment})$$

Internal Rate of Return (IRR):

Internal rate of return can be found by using calculated CRF and the given required life time ($n = 15$ years as per table 7 of I. L. Buxton (1987).

These calculations of four alternative engines are shown in Table 4. 3. 8.

Table 4. 3. 8 Economical Comparison I

Alternatives Engines type	A 5RTA 62U	B 5S60MC	C 6L60MC	D 8PC-40
CMCR kW	10,000	10,000	10,000	10,000
CMCR/MCR %	91 %	98 %	87 %	94 %
SFOC g/kWh	159	170	171	172.7
Fuel cost US\$/year	1,087,836	1,156,680	1,163,484	1,218,571
Fuel cost savings US\$/year	68,844	—	- 6,804	- 61,891
Maintenance cost US\$/year	100,320	93,024	105,062	117,130
Maint. cost saving US\$/year	-7,296	—	-12,038	-24,106
Total saving US\$/year	61,548	—	-18,842	-85,997
M/E investment difference	284,000	—	468,600	-812,000
Reduction gear etc.	—	—	—	230,000
Total investment difference	284,000	—	468,600	- 582,000
Capital recovery factor	0.2167	—	N/A	0.144476
Payback Period	5.75 years	—	N/A	8.5 years
Net present value (NPV)	361,023	—	- 271,136	89,248
Internal rate of return (IRR)	20 %	—	N/A	N/A

The basic alternative 'B' propulsion is a MAN B&W 5S60MC low speed engine developing 10,200 kW at 105 RPM. Alternatives 'A' & 'C' are both two stroke low speed engines. Alternative 'D' is a four-stroke medium speed engine. It has been assumed that all the alternatives have the same propeller diameter, speed and propulsive efficiency.

For the economical comparison the points of interest here are the number of engine units and the initial capital investment.

From the Table 4. 3. 8 it has been observed that alternatives 'A' and 'B' have the same number of units i.e. 5 cylinders. But the initial capital investment of alternative

'A' is higher than alternative 'B' and 'D' by US\$284,000 and US\$866,000 respectively. But alternative 'A' gives savings in fuel consumption amounting to US\$68,844 per year and has a positive net present value (NPV), which is preferable for a shipowner but higher maintenance cost and payback period is 5.75 years which is unfavourable for shipowner.

The initial capital investment of alternative 'B' is lower than alternative 'A' and 'C' by US\$284,000 and US\$468,600 respectively. But higher than alternative 'D' by US\$582,000. The economical study is shown graphically in Fig. 4. 1.

Alternative 'C' has a higher capital investment cost, fuel consumption cost and more number of units i.e. higher maintenance cost and a negative net present value (NPV).

The alternative 'D' has lowest capital investment cost. On the other hand it has the highest number of units i.e. higher maintenance cost.

From an economical point of view alternative 'D' is the better choice due to the lowest investment cost US\$582,000, which is cheaper than the basic alternative 'B'

When taking into consideration the significant factors, influencing main engine selection. The alternatives 'B' is the 1st choice and 'A' is the 2nd choice, (because alternative 'A' has a 5.75 years payback period and higher maintenance cost) due to the following advantages:

- Low capital cost of alternative 'B' in comparison with alternatives 'A' & 'C'
- Lower number of cylinders, and lowest maintenance cost in comparison with all other alternatives.
- Directly coupled to the propeller. Hence there is no reduction gear loss.
- Simplicity on maintenance and overhauling
- More reliable than alternative 'D' due to low RPM.

Further comparison will be made on the basis of 1st choice i.e. the basic alternative 'B'.

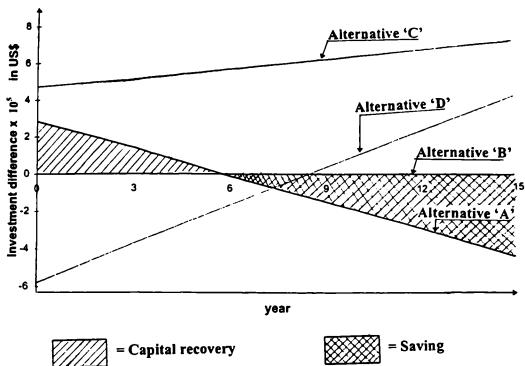

Fig. 4.1 Economical study of four different M/E alternatives

To obtain the minimum fuel consumption, the engine 5S60MC has to be run at 80 % of the MCR. The continuous service rating (CSR) will be then:

$$\text{CSR} = 0.80 \times 10200 = 8160 \text{ kW.}$$

By using the engine layout with Turbo Charger System and without Turbo Charger System in Fig. 4. 2 the specific fuel oil consumptions (SFOC) at CSR B&W Project guide 1993 are:

$$\text{SFOC without TCS} = 170 \text{ g/kWh}$$

$$\text{SFOC with TCS} = 165 \text{ g/ kWh}$$

$$\text{Fuel cost US\$/ year without TCS} = \text{US\$}943,851$$

$$\text{Fuel cost US\$/year with TCS} = \text{US\$}91,691$$

$$\text{Power delivery by turbo charger compound system} = \frac{5\text{g/kWh}}{170} \times 8160 = 240 \text{ kW.}$$

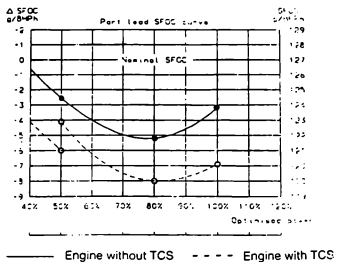

Fig. 4. 2 SFOC as per engine layout with /without TCS at CSR

Source: MAN B&W Catalogue (1994)

Table 4. 3. 9 Cost of Maintenance and spare parts

Diesel generator, PTO & TCS/PTI

Type of Machinery	Cost US\$	Cost US\$ /year
Diesel generator (MDO)	1.34 / h	8040
Diesel generator (HFO)	2.5 / h	15000
Shaft generator (PTO)	2.25 / kW	1125
TCS/PTI (240kW)	10.0 /kW	2400

Table 4. 3. 10 Cost of Lubricating Oil Consumption

Type of Machinery	Spec. lub. oil cons.	Cost US\$/year
Diesel generator (MDO or HFO)	3.0 g/kWh	9090
Shaft generator	0.5 g/kWh	1515
TCS/PTI (240 kW)	0.5 g/kWh	727.2
PTO/PTI (740 kW)	1.0 g/kWh	4484.44

4.4 Economical Comparison II

System Alternative 'E' is the basic 5S60MC without TCS/PTI. Alternative 'F' is 5S60MC with TCS/PTI

Table 4.4.1 Economical Comparison with & without TCS

Alternatives	E	F
Type of machinery	5S60MC without TCS/PTI	5S60MC with TCS/PTI
CSR kW	8160	8160
CSR/MCR %	80	80
SFOC g/kWh	170	165
Fuel cost US\$/year	936,448	908,905
Fuel cost saving US\$/year	—	27,543
TCS/PTI cost US\$	—	150,000
TCS/PTI Lub. oil cons. cost US\$	—	- 727
TCS/PTI Maintenance	—	- 2400
Total saving US\$/year	—	24,415
Total investment US\$	—	150,000
Difference Investment	—	150,000
Capital Recovery Factor (CRF)	—	0.163
Payback Period	—	7.5 years
Net Present Value (NPV)	—	105,869
Internal Rate Return (IRR)	—	14 %

From the Table 4.4.1 it has been calculated that the alternative 'B' has a payback period of 7.5 years, which is unfavourable period for the shipowners. But from the economic point of view the TCS/PTI is better due to the positive value of NPV US\$ 103432.

4.5 Economical Comparison III; with / without Shaft generator

Alternative 'G' is the basic: 3 diesel generator sets using heavy fuel oil of 180 CST.

Alternative 'H' : 1 Shaft generator PTO 500 kW and two diesel generators.

Fuel cost calculation US\$/ year:

Fuel cost for PTO = US\$57,834

Fuel cost for diesel generator = US\$74,088

Table: 4. 5. 1 Economical Comparison, Example III

Alternative	G	H
Type of Machinery	1 DG using HFO	1 PTO
Power/set kW	500	500
SFOC g/kWh	210	170
Fuel cost US\$/year	74,088	56,133
Saving fuel cost US\$/year	—	16,254
Saving in L.O. cons. US\$/year	—	7,575
Saving in maintenance cost US\$/year	—	13,875
Total saving US\$/year	—	37,704
Difference Investment	—	126,000
Capital Recovery Factor (CRF)	—	0.2992
Payback Period	—	3.75 years
Net Present Value (NPV)	—	269,138
Internal Rate of Return (IRR)	—	< 30%

From the above Table it is has been observed that, alternative 'H' has a payout period of 3.75 years, which is a favourable period for a shipowner. Also it has a positive net present value US\$269,138 i.e. it is economically better.

4.6 Economical Comparison IV

Alternative 'J' is the basic with 3 diesel generator sets using MDO

Alternative 'K' is 1 Shaft generator with TCS/PTI and two diesel generator

Fuel cost calculation:

F.O. cost for PTO = US\$56133/year

F.O. cost for diesel generator = US\$116,850/year

F.O. cost saving by TCS = US\$27,543/year

Table 4.6.1 Economical Comparison with Diesel generator & 1 Shaft generator with TCS/PTI and two diesel generators

Alternatives	J	K
Type of machinery	1 DG using MDO	1 PTO/PTI
Power/set kW	500 kW	500 kW
SFOC g/kWh	205	165
Fuel cost US\$/year	116,850	56,133
Saving in fuel cost US\$/year	—	60,717
Saving in TCS US\$/year	—	27,543
Saving in L.O. cons. US\$/year	—	4606
Savings in Maintenance cost US\$/year	—	6915
Total savings	—	99780
Difference Investment	—	312,500
Capital Recovery Factor	—	0.3193
Payback Period	—	3.5 years
Net Present Value	—	733,194
Internal Rate of Return	—	> 30 %

From the Table 4. 6. 1 it is seen that alternative 'K' PTO/PTI has a Payback Period of 3.5 years and a positive net present value more than 0.7 million.

4. 7 Conclusion of this chapter:

By comparing all the alternatives, it may be concluded that, choosing the power take-off with turbo-compound system is the better choice from an economic point of view due to:

- The payback period is only 3.5 years, which is a favourable period for the shipowner, (in the Example IV).
- The net present value (NPV), more than 0.7 million, which is a considerable amount for the shipowner compared with the payback period.
- The internal rate of return (IRR), is $>30\%$, which is about four times higher than the assumed rate of interest ($i = 8\%$).

CHAPTER 5

Engine Selection Process

The selection of the main engine for shipboard use is a comprehensive and difficult task. The selection can not be based on one single factor. There are many possible engine designs, which are capable of meeting most performance requirements, and numerous factors must be considered such as fuel consumption, cost, availability of competitive engines, weight and maintenance considerations such as availability of spare parts, necessity for special tools and the number, type and frequency of the maintenance required. Therefore, the factors that should be considered are operational flexibility, SFOC, obtainable power, possible shaft generator application and propulsion efficiency.

The first and possibly the most important consideration leading to the selection of a diesel engine is to obtain the speed-power curves for all important modes of operation such as fully and lightly loaded; clean hull and calm weather, fouled hull and heavy weather; with and without power take-off loads.

In this study the engine selection process is based on the MAN B&W MC-engine series, in order to select the optimum marine engine. Therefore detailed information on a particular engine is being obtained from project guide.

The current development programme of MAN B&W MC engines comprises engines with all relevant combinations of speed and power for ship propulsion, power range from 1000 bhp to 93000 bhp and speed from 60 r/min to 250 r/min.

The main criteria for an engine selection process have been shown in Fig. 3. 1. Here it would be concentrated on a simple method which can be used, to estimate the

ship's main particulars, the power/speed combination, and then to choose the main engine that fulfils the ship's requirements.

5.1 Ship's Power Requirement

At the initial stage of the process, the shipowner or shipyard generally stipulate the ship type, ship size and the design speed of the ship. From these limited data, the estimation of the power/speed requirement can be an approximation.

On the basis of the main particulars of the ship i.e. length, breadth, draught, block coefficient dead-weight and speed the power requirement can be ascertained by the power-speed curve as shown in Fig. 5. 1.

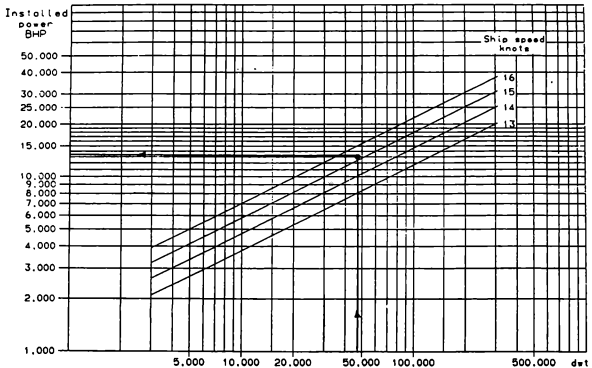

Fig. 5.1 Installed power for bulk carrier, tankers and general cargo ships

Source: MAN B&W Catalogue (1992)

5. 1. 1 Propeller Diameter & Speed

When power requirement has been found, the optimum propeller speed can be found using the optimum propeller diameter.

Using the diagram in Fig. 5. 2 the optimum propeller diameter and speed can be found.

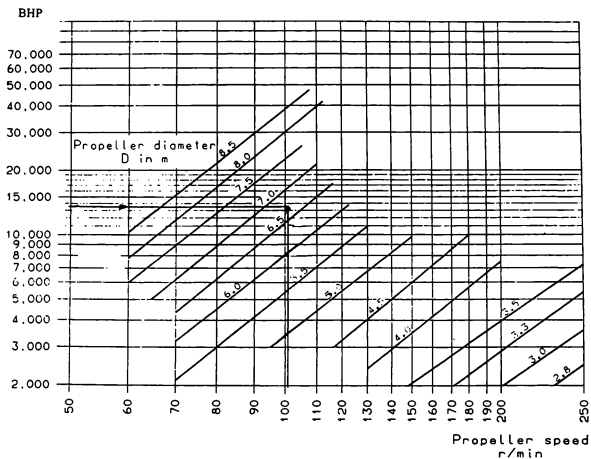

Fig. 5. 2 Engine power, propeller diameter and propeller speed for four-bladed propellers

Source: MAN B&W Catalogue (1993)

5.2 Engine Selection

Once the optimum power/speed combination is established, an engine can be selected which will develop the required horse power at the appropriate rate. It is assumed that the ship under consideration is one which is expected to operate the majority of its time at less than full load.

The main engine selection procedure is to start by finding the relevant engine types and sizes in a certain engine speed range, for example between 100 and 140 r/min.

In Fig. 5.3 the curves I, II, III are called α -curves (as per MAN B&W), and can be used to compare different engine alternatives at varying propeller speeds. It has been seen that, whenever increasing the propeller speed by choosing a smaller diameter i. e. by moving the propeller curve to the right - will decrease the propeller efficiency. However, such a speed increase may make it possible to choose a smaller cylinder diameter and a less expensive engine. The final choice may then depend on a number of factors, such as maximum permissible propeller diameter, the engine room layout, operating costs and vibration aspects.

The increase in power requirement with increasing propeller speed can be illustrated by the so-called α -curves. This curve is often called the "equal ship speed curve," and the correlation can be described as follows:

$$P = P_{ref} \times (n/n_{ref})^\alpha$$

n_{ref} : reference propeller speed

n : selected propeller speed

P_{ref} : power at reference propeller speed (n_{ref})

P : necessary power at propeller speed n

For general cargo, bulk carriers and tanker, the following data may be applied:

$\alpha = 0.15$ for a ship of up to 10,000 dwt

$\alpha = 0.20$ for a ship from 10,000 to 30,000 dwt

$\alpha = 0.25$ for a ship of more than 30,000 dwt

The α -curve can be used to compare different engine alternatives at varying propeller speeds.

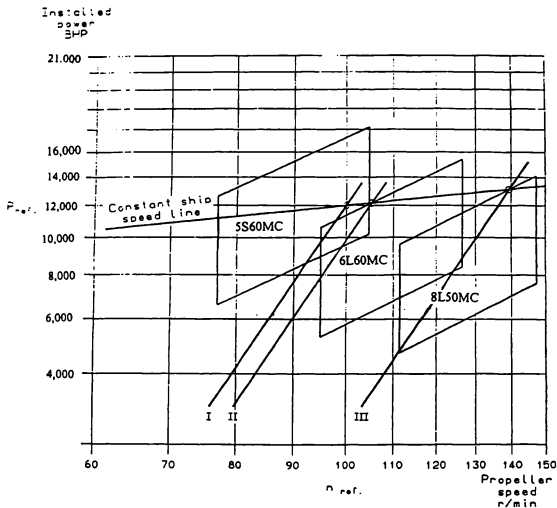

Fig. 5.3 Engine choice for a 46,800 dwt M. Bulk Carrier with 12,100 bhp at 100 rpm

Source: MAN B&W Catalogue (1992)

5.3 Fuel Saving

Fuel cost is an important parameter of the daily operative costs. Hence the possibilities of utilising high efficiency turbochargers for reducing the SFOC have

therefore been kept as the basic version, having the conventional turbochargers as an option.

Higher efficiency turbochargers have been introduced, and the fuel saving potential in using the excess efficiency in a turbo compound system (TCS) is well experienced.

It has already been verified that an increase of the thermal efficiency corresponding to a 2 g/BHP reduction of the SFOC at all loads can be obtained by applying high efficiency turbochargers and optimising the fuel injection system.

The large-bore low speed engines are therefore now available in three categories with respect to the SFOC, is shown in Fig. 5. 4

- With conventional turbochargers
- With high efficiency turbochargers
- With high efficiency turbochargers and TCS.

- (A) With conventional turbocharger
- (B) With high efficiency turbocharger
- (C) With TCS

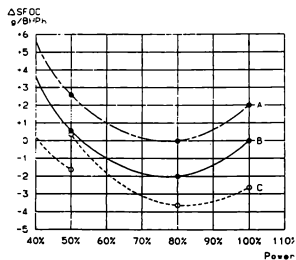

Fig. 5. 4 Part load SFOC curves for the available engine versions

Source: MAN B&W Catalogue (1994)

For the turbocompound system, the power produced by the power turbine is fed back to the crankshaft through a reduction gear thereby allowing a decrease in the power produced by the engine itself and thus a reduction of the specific fuel oil consumption referred to the total power output of the main engine.

The SFOC curves in Fig. 5. 4 are based on the reference ambient conditions stated in ISO 3046/1-1986:

1,000 mbar ambient air pressure

25^o C ambient air temperature

25^o C scavange air coolant temperature

and is related to a fuel oil with a lower calorific value of 42,707 kJ/kg. (10,200 kcal/kg)

For lower calorific values and for ambient conditions that are different from the ISO reference conditions, the SFOC will be adjusted according to the conversion factors in the below table provided that the maximum combustion pressure (P_{max}) is adjusted to the nominal value.

Table 5.1 Conversion factors for adjustment of SFOC

Parameter	Condition change	SFOC
Scav. air coolant temp.	Per 10 ^o C rise	+ 0.60%
Blower inlet temperature	Per 10 ^o C rise	+ 0.20%
Blower inlet pressure	Per 10 mbar rise	- 0.02%
Fuel oil lower calorific value	rise 1% (42,707 kJ/kg)	- 1.00%

5. 3. 1 Optimising Point

The optimising point is the rating at which the turbocharger is matched, and at which the engine timing and compression ratio are adjusted.

As per the power optimising method applied by MAN B&W the optimising point is placed on propeller curve (line1) in Fig. 5. 5 and the optimised power can be from 85 to 100% of specified maximum continuous rating (MCR) power, when turbocharger and engine timing are taken into consideration. In the case of optimised power between 95.3% and 100% of MCR's power, overload running will be possible.

The optimising point should be placed inside the engine layout diagram. Only in special cases, the optimised point can be placed outside the layout diagram, but only by exceeding constant speed line and of course, only provided that the optimising point is located inside the layout diagram and provided that the MCR power is not higher than the nominal maximum continuous rating power.

Fig. 5. 5 shows the point 'A' is a 100% speed and power reference point of the load diagram, and is defined as the point on the propeller curve (line) through the optimising point 'O' having the specified MCR power. Point M is normally equal to point A but point M may in special cases, for example if a shaft generator is installed, can be placed to the right of point A on line 7.

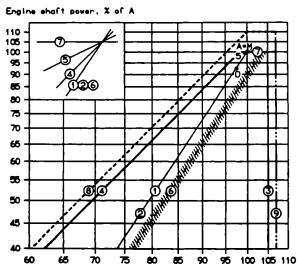

Fig. 5. 5 Engine load diagram

Source: MAN B&W Catalogue (1996)

5.3.2 Fuel Consumption at an Arbitrary Load

When the engine has been optimised in point O in Fig. 5.6 the SFOC in an arbitrary point S_1 , S_2 , or S_3 can be estimated based on the SFOC in the points '1' and '2'.

Then the SFOC for point S_1 can be calculated as an interpolation between the SFOC in points "1" and for point S_3 as an extrapolation.

The SFOC curve through points S_2 , to the left of point 1, is symmetrical about point 1 i.e. at speeds lower than that of point 1, the SFOC will also increase.

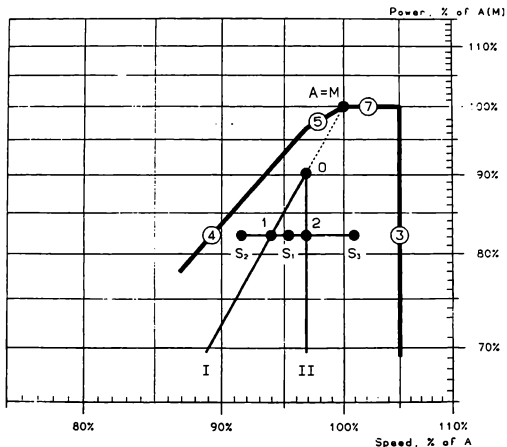

Fig. 5.6 Specific fuel oil consumption at an Arbitrary Load

Source: MAN B&W Catalogue (1995)

5. 4 Engine Room Optimisation

The engine room packages have evolved from all renowned engine builders and are of well designed. The packages could include all or some of the following units:

- Main engine
- Diesel generating sets
- Controllable pitch propeller
- Power Take Off (PTO)
- Remote control system
- Other auxiliary machinery/equipment

5. 4. 1 Electricity Production Units

The electricity is produced on board ship by using the following types of machinery, either running alone or in parallel.

- Diesel generating sets
- Steam driven turbogenerators
- Main engine driven generators
- Emergency diesel generating sets

The selection of above units should be based on an economic evaluation of capital cost, operating costs, and the demand of man-hours for maintenance.

5. 4. 2 Power Take Off (PTO)

Usually a generator driven by a gear box fitted on the front of the main engine coupled to a power take off (PTO), can produce electricity based on the main engine's low SFOC and using of low quality fuel oil. A space saving method is to place the generator adjacent to the engine e.g. integral power PTO system. (See Appendix I).

5. 4. 3 Controllable Pitch Propeller

Controllable pitch propeller equipments are now handling the engines output from 340 bhp to more than 20,000 bhp, and for propellers up to 7 m in diameter. (See Appendix 2).

5. 4. 4 Optimising the Complete Propulsion Plant

The design of the propeller, giving regard to the main variables such as diameter, speed, area ratio etc., is determined by the requirements for maximum efficiency and minimum vibrations and noise levels.

In the case of two-stroke direct drive engines having a flexible layout diagram, the chosen diameter should be as large as the hull can accommodate, allowing the propeller speed to be selected according to optimum efficiency. The optimum propeller speed corresponding to the chosen diameter can be found from Fig. 5. 2.

5. 4. 5 Auxiliary Units

The trend has been towards modularisation of many shipboard installations, as it has been proved that the preparation of individual auxiliary machinery installations often has often been particularly time-consuming for the shipyard.

Therefore, on the basis of experience in combining selected optimum components for auxiliary machinery, almost all engine-makers have designed units for:

- Fuel oil supply unit, which consists of two F.O. supply pumps, two F.O. circulating pumps, two steam preheaters, automatic full flow filter, alarm sensors and control box.
- Crankshaft lubricating oil unit, which consists of magnetic filter, drain tank, two circulating pumps, duplex full flow filter, CJS fine filter with pump in by-pass, alarm sensors and control box.

- Stuffing box drain oil filtration and Piston rod unit, e. g. One drain tank, circulating tank with steam heating coil, circulating pump, CJC fine filter, and pertaining alarm sensors.
- Other auxiliary equipment, such as pumps, coolers, filters for fuel and lubricating oil system; pumps and coolers for cooling water; starting air receiver and compressors; exhaust gas silencer etc.

Operation Behaviours

In the case of a new installation of propulsion power for a ship, attention should be given into the operation behaviours of the engine, which include the vibration characteristics, environmental aspects and exhaust gas emission. The outline measures that can also be taken to counteract any adverse influences arising in the ship.

In the last two decades, there have been drastic changes in the traditions of the shipping and shipbuilding industries. From the statistics it is clear that, the number of 4 and 5-cylinder engines has increased over the years at the expenses of 7 and 8-cylinder engines.

From the technical point of view, two-stroke low speed diesel engines with a low number of cylinders have become very popular for the propulsion of ocean-going ships, mainly on account of their low installation and operating costs.

The concern about vibration and noise on board ships most often stems from a wish to provide comfortable conditions. However, if not adequately dealt with vibrations can reach levels, which threaten the safe operation of mechanical and electronic components and even the stability of major parts of the ship's steel structures.

6.1 Vibration

The vibration characteristics of marine diesels, especially two-stroke low speed engines, which may influence the hull of the ship can be split up into four categories. (1) External unbalanced moments; (2) Guide force moments; (3) Axial vibration in the shaft system; and (4) Torsional vibration in the shaft system. The influence of the excitation sources can be minimised, if necessary measures are considered from the early stage.

6.1.1 External Unbalanced Moments

Piston, piston rod, and crosshead reciprocate, hence accelerate continuously in the vertical direction; the connecting rod reciprocates at its upper end, and rotates at its lower end. The resulting inertia forces create unbalanced external moments.

Among these moments, only the 1st order and 2nd order need to be considered and only for the engines with a low number of cylinders.

The natural frequency of the hull depends on the hull's rigidity and distribution of masses, whereas the vibration level at resonance depends mainly on the magnitude of the external moment and the engine's position in relation to the vibration nodes of the ship.

1. Moments (1st Order)

The 1st order moments occur both in the horizontal and vertical direction of the engine bedplate. These moments usually may vary both in magnitude and phase the z-axis (Longitudinal axis), often having a maximum in the middle part of the engine. For the engines with five cylinders or more, effect of this moment is insignificant to the ship. Resonance with a moment(1st order) may occur for hull vibrations with two or three nodes. Normally, four-cylinder large-bore engines are fitted with

adequate counterweights on the crankshaft, as shown in Fig. 6. 1. These counterweights can reduce the vertical moment to an insignificant value.

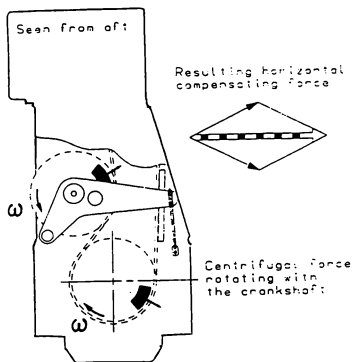

Fig. 6.1 1st order moment compensator

Source: MAN B&W Catalogue (1993)

2. Moment (2nd Order)

The vertical force produced by gas-pressure on the piston crown is, of course, transmitted to the crankshaft by the piston rod, crosshead, and connected rod. Because this last component transmits a force at a cyclically varying angle to the vertical, it produces a horizontal component of force on crosshead bearings and crankshaft bearings. This force produces cylinder-to-cylinder moments in the manner of the inertia forces. The result may be a transverse bending vibration of the

engine. Resonance with 2nd order moment may occur at hull vibrations with more than three nodes.

Precautions need only to be considered for engines with six or less number of cylinders. This moment can be minimised by fitting moment compensators.

3. Power Related Unbalance

If there is a possibility of risk from excitement of 1st order external moment, the concept Power Related Unbalance (PRU) can be used as a guidance to evaluate it.

$$\text{PRU} = \frac{\text{External moment}}{\text{Engine power}} \quad \text{Nm /kW}$$

By using the PRU - value, it is possible to give an estimate of the risk of hull vibration for a given engine. It is shown in Fig. 6. 2. A general study by a manufacturer predicts that an engine with PRU value more than 120 Nm/kW is likely to be fitted with a compensator to eliminate probable adverse consequences of vibrations. As is evident in the figure 6. 2, large bore low speed engines with configuration of up to six units have PRU value more than 120 Nm/kW, hence they are fitted with compensators.

6. 1. 2 Guide Force Moments

The guide force components together with their reactions at the crankshaft bearings produce the following two types of moments:

- 1) Moments about the longitudinal axis
- 2) Moment about a vertical axis

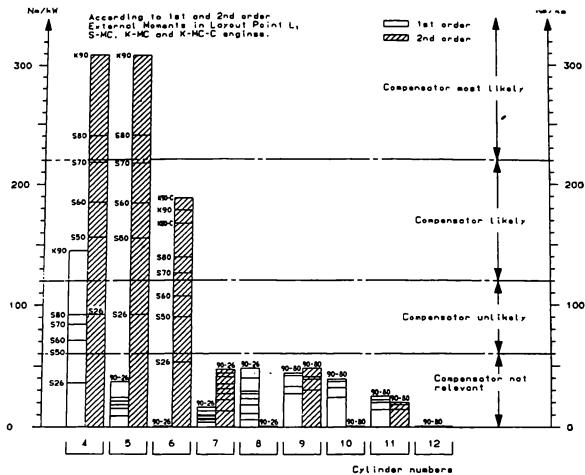

Fig. 6.2 Power Related Unbalance (PRU)

Source: MAN B&W Catalogue (1993)

1. The Moments about the Longitudinal Axis

These moments are equal to the corresponding harmonic components of the engine output torque and tend to rock the engine athwartship. Forward and aft ends of the engine top are vibrating in phase as under these conditions the guide force components of all cylinders are in phase.

From experience it is revealed that mainly the 4 and 5-cylinder engine may suffer from vibration problem excited by this kind of moment.

2. Moments about a Vertical Axis

These moments occur at all minor orders. These moments, which will twist the cylinder sections with respect to each other producing a vibratory mode, are strongly dependent upon cylinder number and firing order.

From experience it is revealed that the 8 and 10-cylinder engines may suffer from vibration problems due to vertical axis moments.

If this form of engine vibration (Longitudinal or vertical axis moment) becomes excessive, it is suggested as a criterion that for a large two-stroke engines running at about 100 to 120 RPM, the amplitude at the engine ends should not significantly exceed ± 0.5 mm. For a 4-stroke medium speed engine these amplitudes should not exceed ± 0.1 mm.

6. 1. 3 Torsional Vibrations

These vibration stresses arise from the crankshaft twisting and untwisting, winding up rhythmically first in one direction and then in other, due to vibration of the whole shafting system. The vibration stress in a shaft depends also on the number of cylinders, cycles of operation of the engines, arrangement of the crankarms, and magnitude of individual torsional forces. In general, torsional vibration stress will decrease as the order number increases. The torsional vibration conditions may require the for following installations.

- Plants with controllable pitch propeller
- Plants with unusual shafting layout and for special requirements
- Plants with 8, 10, 11 or 12 cylinders engines

Engines with 6 or less cylinder numbers require special attention. Due to heavy excitation, the natural frequency of the system with on-node vibration should be

situated away from the normal operating speed range, to avoid its effect. This can be minimised either by changing the masses or the stiffness of the system, so as to give a much higher, or much lower, natural frequency, called undercritical or overcritical running, respectively.

6.1.4 Axial Vibration

The axial vibration arises from the crankshaft being alternately compressed and stretched along its axis in a concertina-like manner. This form of vibration is not so commonly encountered as torsional vibration.

Generally, only zero-node axial vibrations are of interest. Thus the effects of the additional bending stresses in the crankshaft and possible vibrations of the ship's structure due to the reaction force in the thrust bearing are to be considered.

Normally, an axial damper is used to the engines when necessary, to minimise the effects of the axial vibrations.

6.2 Environmental Aspects

Nowadays, more emphasis is being given to environmental issues. Noise is an undesirable sound. Excessive noise is considered as a form of pollution that, in the long run, may cause permanently reduced hearing. As a consequence, authorities now demand that noise levels are kept below certain specified limits. The greater demand for noise limitations in the maritime area has of course, prompted wide interest. Consequently, greater demands are now made on the engine designer/manufacturers to provide more detailed and precise information regarding the various types of noise emission from the engine.

The sensitivity of the human ear is closely related to frequency (Hz = vibrations per second). Sensitivity is low at low frequencies, for which reason it is often necessary to take measurements at different frequency ranges. Normally, these

measurements are made in the so - called Octave bands frequencies, which are named according to their geometrical average frequencies 31.5, 63, 125, 250 etc. Up to 16,000 Hz, are determined by ISO.

On the basis of theoretical calculations and actual measurements it was introduced computerised application system to provide data regarding the sound levels of the following engine-related noise emissions, which are typical for two-stroke low speed engines.

1. Exhaust gas noise
2. Airborne noise
3. Structure - borne noise excitation.

6. 2. 1 Exhaust Gas Noise

The exhaust stack is perhaps the strongest source of engine noise, and must be provided with a muffler within the exhaust line. Often the waste-heat heat exchanger is sufficient for this duty. Two-stroke slow speed engines are normally equipped with a large gas-receiver located between the cylinder's gas outlets and the turbocharger.

Due to its proper location, this gas-receiver also functions as a kind of exhaust gas silencer, particularly dampening the low frequency gas pulsation's that are inherent to the exhaust gas from the cylinders.

The noise level is based on an actual distance of 15 metres from the top of the funnel to the bridge wing. The curve sheet (Fig. 6. 3) shows that the noise level in the octave band frequencies among 125 and 1,000 Hz is decisive for the total noise level of NR81 and that the A- weighted sound level corresponds to 85 dB(A). To meet the maximum permissible noise level of 65 dB(A) on the bridge wing, a relatively volumes 25 dB(A) exhaust gas silencer of the absorption type will, normally, be adequate, as this dampens the dominating frequency ranges.

6. 2. 2 Airborne Noise

Within the machinery space, the turbocharger is the strongest source of airborne noise, with the noise being radiated from the turbocharger surfaces, from the surfaces of adjoining intake and exhaust ducting, and from the air intake opening. To combat this, engine builders insulate the surfaces, and fit sound baffles around intake openings. The engine's average noise levels is measured in accordance with International Council on Combustion Engines (CIMAC's) recommendations for measurements of the overall noise for reciprocating engines.

The calculated average sound level corresponds to the average value of sound intensity measured at different points around the engine. Measuring points are located at two or three metres height levels around the engine, and at a distance of approximately 1 metre from the engine's surface.

6. 2. 3 Structure-borne Noise Excitation

The vibration energy, transferred between the contact surfaces of the engine bedplate and the ships are largely amplitude-dependent, for which reason the level of velocity can normally, be employed as a unit of measurement. An example of sources that can generate vibrational energy is the pulses caused by the engine's combustion process and the reciprocating movement of the pistons.

Similar to the sound pressure level, the level of velocity is best expressed in dB:

Velocity level (dB),

$$L_v = 20 \times \text{Log}_{10} (v/v_o); \quad \text{re}_{v_o} = 5 \times 10^{-8} \text{ m/s}.$$

The reference velocity value (re_{v_o}) used corresponds to the intensity and sound pressure reference value. (This value is often used 10^{-9} m/s).

The velocity level of a two-stroke engine is, on average, approximately 15-20 dB lower than that of a medium speed four-stroke engine that, therefore, may sometimes have special vibration isolators built-in between the engine feet and the tank top of

the ship. The achieved structure-borne sound insulation is of some 15-20 dB, which means that the final result corresponds to the level of two-stroke engines mounted on cast iron or epoxy chocks.

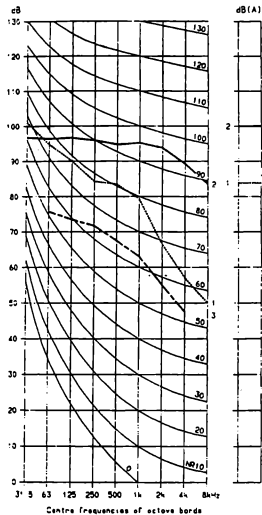

1. Exhaust gas - distance 15 m (re 2×10^{-5} Pa)
2. Airborne - average (re 2×10^{-5} Pa)
3. Structure-borne - engine foot, vertical (re 5×10^{-8} m/s)

Fig. 6. 3 ISO's NR curves and noise levels for a low speed diesel engine

Source: MAN B&W Catalogue (1995)

6.3 Exhaust Gas Emission Control

Environmental considerations will become an increasingly important factor in the future when planning marine propulsion and electrical power generating systems. New environmental legislation will impose limits to harmful exhaust gas emissions. Such requirements may differ from area to area.

Sulphur Oxide (SO_x) and Nitrogen Oxides (NO_x) are the gases from marine diesel engines that might primarily be affected in the future through various regulations. The Marine Environment Protection Committee (MEPC) of the International Maritime Organisation (IMO) has set a target to reduce SO_x emissions by 50% and NO_x emissions by 30% by the year 2000. A maximum fuel bunker sulphur content of 1.5% has been proposed.

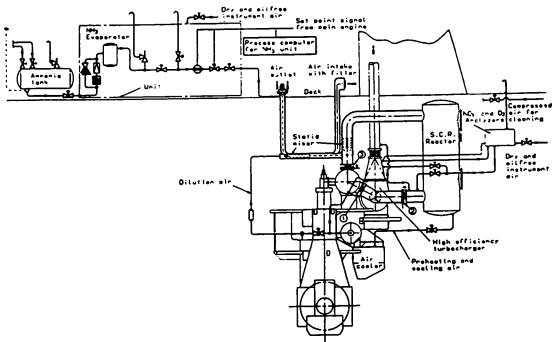

Fig. 6.4 Schematic layout of SCR system for a low speed diesel engine

Source: MAN B&W Catalogue (1993)

Two-stroke low speed diesel engine normally has a very clean combustion, meeting the soot and particle emission limits but, as a consequence of its high thermal efficiency, the emission of NO_x is comparatively high, SO_x emission can be controlled either by lowering the sulphur content in the fuel oil, or by employing exhaust gas desulphurization techniques.

NO_x control will, dependent on the possible limits, require some additional equipment. Although water emulsification of fuel oil will reduce NO_x by up to 30%, a simple new equipment to control the emission of NO_x by means of a technique using selective catalytic reduction (SCR) by ammonia as shown in Fig. 6.4. Such equipment makes it possible to comply with virtually potential legislative NO_x emission limits.

CHAPTER 7

Summary and Conclusions

In the past twenty years the diesel engine has captured a large market share in the propulsion power of merchant ships. It can be said with a degree of certainty, that the diesel engine will continue to remain the first choice as propulsion for the merchant fleet in the foreseeable future.

Hundreds of developments of low and medium speed diesel engines have been made by the engine makers to improve the thermal efficiency and reduce the specific fuel oil consumption (SFOC). Much improvement has been done by utilising waste heat for heating and electrical generation.

It has already been achieved, and further development will continue for optimising the total economy, also focusing on achieving even better reliability.

The selection of marine diesel engine is a system engineering. Although the criteria in simplification, capital cost, operating cost and propeller speed etc. must be given the priorities, the other factors also have a substantial influence on overall economy.

From the technical study and economical comparison of the slow and medium speed engines in Chapter 4, the slow speed engine compared with medium speed diesel engine is more economical in terms of fuel economy and maintenance expenses, although the medium speed engines are of lower capital cost.

For ships with sufficient space for engine room, the low speed engine provides the simplest possible propulsion arrangement without gearing arrangements and less cylinder numbers, than medium speed engine delivering same power.

The main advantages of low speed diesel engines are reliability, simplicity and durability. That is why, whenever technically and economically possible, a low speed engine is, and will always be, the first choice for a ship.

The medium speed diesel engine, on the other hand, has clear advantages for applications such as multi-engine propulsion system with operational flexibility, and where low-head room is required.

The main criterion such as reliability, durability and safety at sea have been improved greatly in medium speed engines, since the major components have been modified and the time between overhaul (TBO) has been lengthened.

The economical comparison between the four different alternatives in Chapter 4 shows that, the MAN B&W 5S60MC two stroke slow speed engine is the most suitable engine for the selected Bulk Carrier, because of high degree of reliability, low capital cost and low maintenance cost. On the other hand SULZER 5RTA 62U slow speed engine has an advantage of fuel economy over the engine MAN B&W 5S60MC. Fig. 4. 1 shows the initial capital investment of alternative 'B' is lower than alternative 'A' and 'C', but higher than alternative 'D'. Alternative 'C' has a higher capital investment, fuel consumption cost and more number of units i.e. higher maintenance cost. The alternative 'D' requires the lowest capital investment but has highest number of units i.e. higher maintenance cost.

Besides the consideration of the economic aspects, the other selection factors, such as speed power curve, required engine power, propeller revolutions etc. are also important.

Environmental consideration are gaining importance in the future. The two stroke low speed engine normally has very clean combustion meeting the soot and particle emission limits but, as a consequence of its high thermal efficiency, the emission of NO_x is comparatively high. The emission of NO_x is controlled by means of a technique using Selective Catalytic Reduction (SCR) by ammonia.

The two stroke slow speed diesel engine is the most well established marine propulsion engine and the development in terms of output power has been vigorous.

So, the selection of slow speed diesel engine for marine propulsion power is the best choice.

Bibliography

Brown, David T (1985). *A History of the Sulzer low-speed marine diesel engine*. Winterthur, Switzerland: Sulzer Brothers Ltd.

Buxton, I L (1987). *Engineering Economics and Ship Design*, third edition. Tyne and Wear: British Maritime Technology Limited.

Engja, Hallvard (1989). 'Waste heat energy recovery ' WEGEMT, vol. 8, page 1-17

Harrington , Roy L (ed.) (1980). *Marine Engineering*, third edition. New York, The Society of Naval Architects and Marine Engineers.

IMO (1995). *Prevention of air pollution from ship: Draft Protocol of 1997 to ammend the international convention for the prevention of pollution from ships, 1973 as modified by the Protocol of 1978 relating thereto*. (MEPC 38/9) London: IMO November, 1995.

IMO (1996). *Prevention of air pollution from ships: Draft Protocol of 1997 to amend the international convention for the prevention of pollution from ships, 1973 as modified by the Protocol of 1978 relating thereto*. (MEPC 38/9/10) London: IMO April, 1996.

Institute of Marine Engineers (1990). *IMAS 90-Marine Technology and the Environment*, London, May, 1990: London: Marine Management Holdings.

Ishida Kenji (1996). *Ships Machinery and Propulsion System. Lecture notes*. Malmö, Sweden: World Maritime University.

Knak, Christen (1990). *Diesel Motor Ship's Engine and machinery*. London: Marine Management (Holdings) Limited for the Institute of Marine Engineers.

Leach, R M and Milton, J H (1980). *Marine Steam Boilers*, London: Butterworths & Co. (Publishers) Ltd.

Lebech, Mogens (1959). *B&W Museum*, Copenhagen: O. C. Olsen & Co. A/S.

Listewnik, Jerzy (1995). *Marine Diesel Engines*. Lecture notes. Malmö, Sweden: World Maritime University.

MAN B&W Publications (1995). *Environmental Aspects of Two-Stroke Low speed, Crosshead, Uniflow Diesel Engines*, Copenhagen: MAN B&W A/S.

MAN B&W Publication (1994). *Exhaust Gas Data and Waste Heat Recovery System*, Copenhagen: MAN B&W A/S.

Morton, Thomas Dunn (1978). *Motor Engineering Knowledge for Marine Engineers*, (Reed's Marine Engineering Series, vol.12) London: Thomas Reed Publications Limited.

Motor Ship (1994). *16th Annual International Marine propulsion conference* 10-11 March 1994, London, UK. London: Reed Business Publishers.

Taylor, D A (1990). *Introduction to Marine Engineering*, 2nd edition. London: Butherworth & Co (Publishers) Limited.

Thomas D Morton (1979). *Reed's Steam Engineering Knowledge for Marine Engineers*, Volume 9. London: Thomas Reed Publications Ltd.

Vertec Marine Technology Consultants (1985). *Vibration Control in Shipping*.
Hovic, Norway: A. S. Vertec.

Wilbur, C T, D A Wight (1984). *Pounder's Marine Diesel Engine*, 6th edition.
London: Butterworth & Co (Publishers) Ltd.

Several Standard PTO Systems

	Alternative generator positioning		Design	Seating	Total efficiency
PTO/RCF	1a	1b	BW I/RCF	At engine (vertical generator)	88 - 91
	2a	2b	BW II/RCF	On tank top	88 - 91
	3a	3b	BW III/RCF	At engine	88 - 91
	4a	4b	BW IV/RCF	On tank top	88 - 91
PTO/CFE	5a	5b	BW I/CFE	At engine (vertical generator)	81 - 85
	6a	6b	BW II/CFE	On tank top	81 - 85
	7a	7b	BW III/CFE	At engine	81 - 85
	8a	8b	BW IV/CFE	On tank top	81 - 85
	9a	9b	DMG/CFE	At engine	84 - 88
	10a	10b	SMG/CFE	On tank top	84 - 88
PTO/GCR	11		BW I/GCR	At engine (vertical generator)	92
	12		BW II/GCR	On tank top	92
	13		BW III/GCR	At engine	92
	14		BW IV/GCR	On tank top	92

BW III/RCF (3b) and BW III/GCR (13) and BW II/GCR (12) are standard solutions

Fig. 5.7 Types of PTO

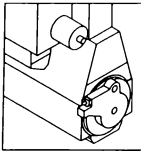

Turbo compound system:

TCS/PTI

BW L60/R/TCS 450

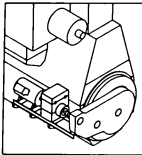
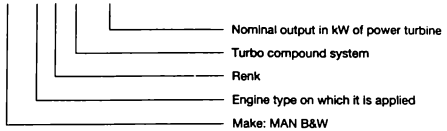

Power take off:

PTO

BW III L60/RCF 1100-60

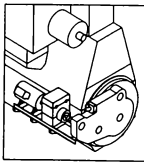
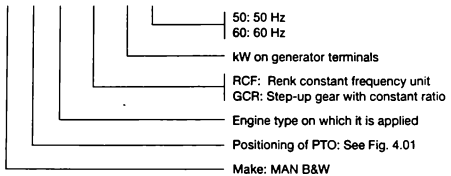

Power take off/power take-in:

PTO/PTI

BW III L60/RCF 700-60/TCS 450

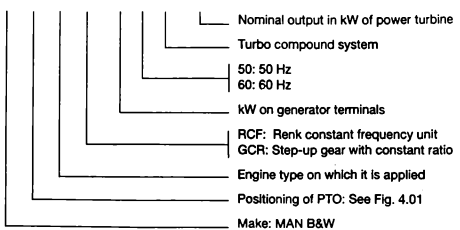

Fig. 5. 8 Designation of TCS/PTI, PTO and PTO/PTI

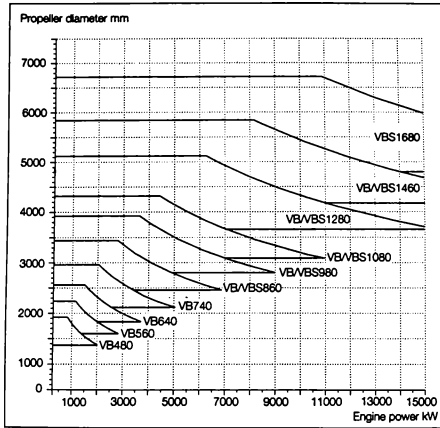

Fig. 9 Propeller equipment programme

The new combustion chamber and cylinder liner

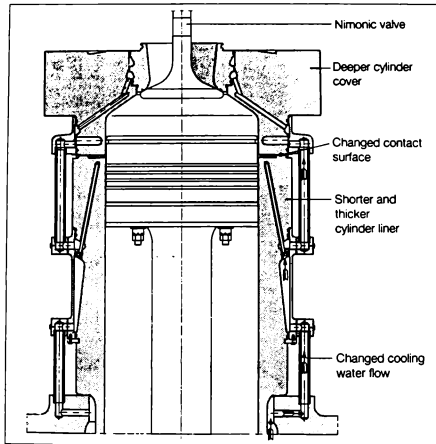

Fig. 2. 10 *The new combustion chamber design*

TABLE 7: CAPITAL RECOVERY FACTOR

YEAR	DISCOUNT RATE P. C.									
	1	2	3	4	5	6	7	8	9	10
1	1.010000	1.020000	1.030000	1.040000	1.050000	1.060000	1.070000	1.080000	1.090000	1.100000
2	0.907512	0.913050	0.922611	0.930196	0.937805	0.945437	0.953092	0.960769	0.968469	0.976190
3	0.846022	0.847555	0.853530	0.860399	0.867269	0.874140	0.881052	0.888004	0.895005	0.902115
4	0.795281	0.792624	0.799027	0.805490	0.812012	0.818594	0.825235	0.831931	0.838689	0.845471
5	0.760400	0.752158	0.748355	0.744427	0.740475	0.736509	0.732529	0.728535	0.724527	0.720517
6	0.732348	0.728526	0.724598	0.720674	0.716751	0.712830	0.708910	0.704991	0.701073	0.707160
7	0.710428	0.704518	0.700569	0.696610	0.692651	0.688692	0.684733	0.680774	0.676815	0.702845
8	0.130690	0.136510	0.142356	0.148228	0.154122	0.160036	0.165968	0.171918	0.177887	0.183874
9	0.116740	0.122513	0.128434	0.134493	0.140590	0.146722	0.152886	0.159080	0.165304	0.171561
10	0.105582	0.111327	0.117121	0.122911	0.128705	0.134503	0.140304	0.146108	0.151915	0.157726
11	0.096454	0.102178	0.108077	0.114149	0.120293	0.126509	0.132795	0.139151	0.145476	0.151871
12	0.088649	0.094560	0.100462	0.106352	0.112231	0.118107	0.123980	0.129850	0.135717	0.141581
13	0.082413	0.088318	0.094200	0.100064	0.105916	0.111756	0.117583	0.123407	0.129227	0.135044
14	0.077901	0.082802	0.087696	0.092582	0.097461	0.102332	0.107195	0.112050	0.116906	0.121763
15	0.074124	0.077825	0.081517	0.085199	0.088871	0.092534	0.096187	0.099831	0.103465	0.107099
16	0.071943	0.073650	0.075411	0.077216	0.079064	0.080955	0.082889	0.084865	0.086882	0.088940
17	0.069258	0.069970	0.070733	0.071549	0.072419	0.073343	0.074311	0.075324	0.076381	0.077483
18	0.066982	0.066702	0.067209	0.067892	0.068654	0.069495	0.070416	0.071417	0.072498	0.073659
19	0.065052	0.063782	0.062814	0.062139	0.061745	0.061521	0.061467	0.061573	0.061839	0.062265
20	0.065413	0.061157	0.067216	0.073582	0.080243	0.087185	0.094393	0.101852	0.109544	0.117460
21	0.053031	0.058785	0.064872	0.071280	0.077996	0.085005	0.092289	0.099832	0.107641	0.115824
22	0.050864	0.056631	0.062747	0.069199	0.075971	0.083044	0.090406	0.098032	0.105903	0.114105
23	0.048886	0.054668	0.060814	0.067309	0.074137	0.081278	0.088714	0.096442	0.104462	0.112772
24	0.047073	0.052871	0.059047	0.065519	0.072371	0.079619	0.087189	0.095178	0.103503	0.112180
25	0.045407	0.051220	0.057428	0.064012	0.070952	0.078227	0.085811	0.093719	0.101968	0.110548
30	0.038748	0.044450	0.051019	0.057830	0.065051	0.072649	0.080586	0.088827	0.097336	0.106179

YEAR	DISCOUNT RATE P. C.									
	11	12	13	14	15	16	18	20	25	30
1	1.110000	1.120000	1.130000	1.140000	1.150000	1.160000	1.180000	1.200000	1.250000	1.300000
2	0.583734	0.591998	0.599484	0.607399	0.615716	0.624432	0.633558	0.643094	0.653050	0.663427
3	0.409213	0.416349	0.423532	0.430761	0.437977	0.445180	0.452368	0.459542	0.467705	0.475857
4	0.322328	0.329234	0.336194	0.343205	0.350265	0.357375	0.364535	0.371745	0.378989	0.446129
5	0.270730	0.277410	0.284151	0.291204	0.298316	0.305409	0.312477	0.319530	0.327184	0.335822
6	0.236377	0.243226	0.250153	0.257157	0.264237	0.271390	0.278616	0.285914	0.293284	0.300724
7	0.212125	0.219118	0.226141	0.233192	0.240269	0.247371	0.254498	0.261650	0.268826	0.276026
8	0.194321	0.201303	0.208307	0.215330	0.222380	0.229454	0.236554	0.243680	0.250831	0.258006
9	0.180602	0.187679	0.194689	0.202116	0.209574	0.217062	0.224580	0.232129	0.239708	0.247317
10	0.169601	0.176684	0.183690	0.190714	0.197752	0.204804	0.211870	0.218951	0.226046	0.233155
11	0.161121	0.168615	0.176441	0.183999	0.191289	0.198311	0.205064	0.211748	0.218362	0.224906
12	0.154027	0.161437	0.168896	0.176699	0.184841	0.192311	0.199104	0.206228	0.212682	0.219466
13	0.148131	0.155677	0.163250	0.171164	0.179110	0.187184	0.195386	0.203716	0.212174	0.220860
14	0.143228	0.150771	0.158467	0.166400	0.174668	0.183269	0.192198	0.199454	0.207036	0.214944
15	0.139065	0.146824	0.154742	0.162909	0.171317	0.179964	0.188841	0.197948	0.207284	0.216849
16	0.135517	0.143390	0.151426	0.159615	0.167948	0.176424	0.185141	0.194098	0.203294	0.212729
17	0.132471	0.140457	0.148600	0.156905	0.165367	0.173985	0.182758	0.191686	0.200869	0.210305
18	0.129843	0.137937	0.146201	0.154621	0.163188	0.171885	0.180703	0.189639	0.198683	0.207932
19	0.127562	0.135763	0.144134	0.152663	0.161354	0.170197	0.179191	0.188335	0.197629	0.207074
20	0.125574	0.133879	0.142354	0.150986	0.159761	0.168676	0.177720	0.205337	0.215191	0.225271
21	0.123838	0.132240	0.140814	0.149555	0.158417	0.167416	0.176544	0.185799	0.195181	0.204691
22	0.122313	0.130811	0.139479	0.148309	0.157296	0.166433	0.175720	0.185158	0.194746	0.204484
23	0.120971	0.129580	0.138319	0.147211	0.156258	0.165463	0.174827	0.184349	0.194029	0.203867
24	0.119787	0.128463	0.137308	0.146303	0.155450	0.164753	0.174214	0.183832	0.193607	0.203544
25	0.118740	0.127500	0.136428	0.145519	0.154769	0.164173	0.173731	0.183444	0.193311	0.203342
30	0.115023	0.124144	0.133411	0.142803	0.152300	0.161886	0.171564	0.181334	0.191196	0.201151

Part II - Making Engineering Economy Calculations