

World Maritime University

The Maritime Commons: Digital Repository of the World Maritime University

World Maritime University Dissertations

Dissertations

1990

Intelligent training techniques through computer based systems

J. K. M. Nair
WMU

Follow this and additional works at: https://commons.wmu.se/all_dissertations

Recommended Citation

Nair, J. K. M., "Intelligent training techniques through computer based systems" (1990). *World Maritime University Dissertations*. 1017.

https://commons.wmu.se/all_dissertations/1017

This Dissertation is brought to you courtesy of Maritime Commons. Open Access items may be downloaded for non-commercial, fair use academic purposes. No items may be hosted on another server or web site without express written permission from the World Maritime University. For more information, please contact library@wmu.se.

WORLD MARITIME UNIVERSITY
Malmö, Sweden.

INTELLIGENT TRAINING TECHNIQUES
through
COMPUTER BASED SYSTEMS

by

J. K. M. Nair,
India.

A paper submitted to the faculty of the World Maritime University in partial satisfaction of the requirements for the award of a

MASTER OF SCIENCE DEGREE
in
MARITIME EDUCATION AND TRAINING
(MARINE ENGINEERING)

The contents of this paper reflect my personal views and are not necessarily endorsed by the university.

Signature:

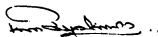

Date:

17.08.1990

Supervised and assessed by:

Charles E. Mathieu,
Professor,



Maritime Education and Training,
World Maritime University.

Co-assessed by:

Dr. L. R. Chary,

General Manager (Computers & Communication)

Shipping Corporation of India Ltd.,

Bombay, India.

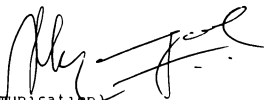

ॐ

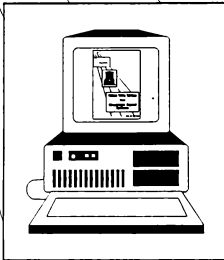
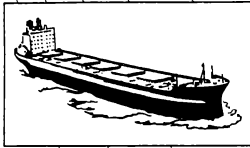

Intelligent Training Techniques
through
**Computer Based
Systems**

J. K. M. Nair, India



ज्ञानेन तु तदज्ञानं
येषां नाशितमात्मनः।
तेषामादित्यवज्ज्ञानं
प्रकाशयति ततपरम्॥

*“jñanena tu tad ajñanam yesam nasitam atmanah
tesam aditya-vaj jñanam prakasayati tat param”*

When one is enlightened with knowledge by which nescience is destroyed, then his knowledge reveals everything as the sun lights up everything in the daytime.

- Bhagawad Gita 5.16

Author's Note:

This dissertation is produced as part of the requirement for the M.Sc degree in Maritime Education and Training (Engineering) of the World Maritime University, Malmo, Sweden. No part of this work may be reproduced; copied, abstracted or used in any manner without permission of the author.

The views, opinions and conclusions drawn are those of the author and do not necessarily be endorsed by any agency or organisation.

CONTENTS

	Page
Acknowledgements	iii
Preface	v
Glossary of Terms	vii
List of Illustrations	x
Abstract	xii
Chapter 1. Introduction	1
Chapter 2. Indian Shipping- An Overview	7
2.1 India, the nation.	
2.2 Maritime Industry of India	
2.3 Projections towards 2000 AD	
Chapter 3. The Shipping Corporation of India ltd.	16
3.1 Objectives of SCI	
3.2 SCI fleet	
3.3 SCI's vision of the future	
Chapter 4. Maritime Training Institute of SCI	23
4.1 Existing programmes	
4.2 Proposed programmes	
Chapter 5. Population Analysis	26
5.1 Discussion of Objectives	
5.2 Who is he?	
5.3 Assessment of SCI population	
5.4 Influencing factors	

Chapter 6.	Computers in Shipping	51
	6.1 Computers in ship design & ship building	
	6.2 Computers on board ships	
	6.3 Systems in a shipping co. office	
	6.4 Communication & information channels	
	6.5 Computer application to offshore	
	6.6 Computers in SCI	
Chapter 7.	Computers in education	85
	7.1 Historical background	
	7.2 Computers in human information processing	
	7.3 Teaching with computers	
	7.4 Advantages of computerized education	
	7.5 Tips for computer course design	
Chapter 8.	Towards Modern Systems	107
	8.1 Simulation systems	
	8.2 Knowledge based systems	
	8.3 Expert systems	
	8.4 Few words about Fuzzv Logics	
Chapter 9.	Specific need for SCI & MTI	121
	9.1 Present system at MTI	
	9.2 Requirements at MTI	
	9.3 Suggestions & proposals	
Chapter 10.	Conclusion	133
Bibliography		137

Acknowledgements

No thesis of this nature can be produced without help and encouragement from others. There are many who helped me directly and indirectly and aided me in getting this work completed successfully. I thank them all, for their active support.

In writing this thesis, I was privileged in many ways. First of all I came to learn about my own weaknesses and strengths. Secondly I came to learn and work with computers more. And, thirdly I came across good many excellent publications and papers, which I had to study to get what I wanted. It has been a challenging work.

Now, I wish to express my sincere thanks to:

My colleagues at SCI and MTI for helping me with all the information.

Dr. L. R. Chary, GM(C&C) for guiding me through my thesis and for his valuable suggestions and comments as a co-assessor to the thesis.

SCI management for sponsoring me to undergo the two year course at the World Maritime University, Malmo.

WMU and SIDA for making the two year stay at Malmo fruitful.

Friends, colleagues and staff, especially from the WMU library for their immense help and suggestions.

Professors and lecturers, who gave us valuable knowledge.

Prof. C. E. Mathieu and Lecturer Russell for their guidance and directions.

Capt. M. X. Corera for all his encouragement and guidance.

I acknowledge and thank all those who gave permission to quote from their work.

Thanks

And finally, I dedicate this thesis to my beloved family who had to put up with the hardships of prolonged separation. It was their moral support and encouragement which made these two years possible.

J.K.M.Nair,
SCI, Bombay.
sept 1990.

Preface

In this modern world, computer literacy is essential for progress. The shipping industry is no exception. The Shipping corporation of India, (SCI) has gone ahead with massive computerization. Computers are being fitted on board ships and in shore offices. This results in an urgent need for training the personnel in computers.

This thesis is an attempt to study the usage of computers in shipping and how they can be used in maritime education. Training in this field differs mainly on the aspects of achieving operational efficiency and on the effect of active interaction of the participants. Although this thesis principally keeps in view the requirements of SCI, it could be modified for application to any other organization.

The object of this thesis is to emphasize the need of computer based education systems. Though it can serve a course designer as a guide and tell him how to go about it, it was not my idea to focus only on an actual course curriculum or time tabling. They can be tailor made to suit each category of personnel. My aim was to put a bit more technology towards SCI and maritime training, which I am sure will be well received by the SCI management.

It may seem that I have tried to bite a little too much. In trying to keep general, I felt that the reader could easily go to specific areas with the guidance given here. Relevant books and references are given in the bibliography for his assistance.

This thesis is also an interesting product of modern technologies. I have used computers extensively for text processing, graphics and for drawing and flow charting purposes. It has really helped me in keeping up with the large volume of references, listing and also in editing

and further rearranging as was required from time to time. Added to this, I can now carry these hundred odd pages in 2 floppy disks to India; just like a big genie locked in a bottle, to be released to its final size later.

As you go through this thesis, you will probably notice more pictures and illustrations. These were used because a picture could give more information than a thousand words and illustrate ideas more clearly. Of course, the fear of increasing the pages had always restrained me to keep written material to the minimum. I have used terms like student, trainee, participant and learner to name the target or receiver in a teaching and learning process, and terms like trainer, teacher and faculty for the one who delivers knowledge.

Finally, I don't want you to jump to any conclusion that this thesis is a magic pill for developing a computer course. There is much more to read and understand. All I have tried to do is to take you through a path for reaching the goal; just like a guide in a conducted tour. Like him, I have explained the salient points. More detailed descriptions and methods are available in numerous books, periodicals and technical papers. Some of these, I have quoted in my references.

If you feel that there is a better way or that there is some thing which could be added, I would happily welcome all your valuable suggestions.

J. K. M. Nair.
India.

LIST OF ABBREVIATIONS and GLOSSARY of TERMS

ARPA	- Automatic Radar Plotting Aid
B & T	- Bulkcarrier & Tanker Department
CAD	- Computer Aided Design
CAI	- Computer Aided Instruction
CAM	- Computer Aided Manufacturing
CAL	- Computer Assisted Learning
CAT	- Computer Assisted Training
CBE	- Computer Based Education
CBI	- Computer Based Instruction
CBLA	- Computer Based Learning Aids
CEL	- Computer Enhanced Learning
CIV	- Computer Interactive Video
CMi	- Computer Managed Instruction
CPS	- Coastal and passenger Services
DOT	- Department of Transport
ES	- Expert System
GMDSS	- Global Maritime Distress & Safety System
ICAI	- Intelligent CAI
ICD	- Internal Container Depot
IMO	- International Maritime Organisation
KB	- Knowledge Base
K S A	- Knowledge, Skill, Ability (or Attitude)
MIS	- Management Information System
MOT	- Ministry of Transport
MTI	- Maritime Training Institute
OBO	- Oil Bulk Ore carrier
P&A	- Personnel and Administration Dept
RT	- Radio Telephony
SATCOM	- Satellite Communication
SATNAV	- Satellite Navigation
SCI	- Shipping Corporation of India
VDU	- Visual Display Unit
VHF	- Very High Frequency (communication equipment)
VLCC	- Very Large Crude Carrier

Algorithm - A step by step procedure that describes how a specific task is to be performed or how a problem is to be solved.

Artificial Intelligence - Area of computer science that involves inferential thinking and problem solving.

Authoring System - Programs useful for writing or authoring specific software.

BASIC - Beginners All Purpose Symbolic Instruction Code, a computer programming language.

Bayesian - Subjectivist (refer works of de Finnetti & Lindley and annex 8.7)

Bhagavat Gita - The most important part of the world's best epic " The Mahabharata" from India. Here Lord Krishna narrates the good and bad of duty, performance and knowledge.

Cobol - Common Business Oriented Language.

Cognitive - Connective to intellectual means. See annex 5.5

Compiler - A program that translates a high level language into machine code.

Courseware - Software intended for instruction purposes like a disk, slides, printed handouts etc.

Database - A storage or collection of data or information for easy access and cross reference.

Domain - Specified area or a specified set of values.

Expert System - A computer program which incorporates knowledge of several human experts.

Fortran - Formula Translation, a computer language.

Fuzzy Logic - A logic which is not clearly defined.

GIGO - Garbage In, Garbage Out.

Hardware - All the tangible parts of a computer system, electronic and mechanical.

Heuristic - An incomplete method for problem solving for which no deterministic solution strategies are known. They are mainly rule of the thumb methods.

Inference Engine - A unit which processes and analyses the data.

Interface - The electronic component or software that makes

it possible for the computer to communicate with its peripherals and outside world.

Main Frame - A computer that is much bigger and more powerful

Mechatronics - is a term describing the integration of mechanical and electronic engineering

Media/Medium - A method or aid used for training

Modem - A device that enables information from a computer to be sent to or received from another device (eg. telephone).

Net-working - Linking computers and peripherals so that users can share information and resources.

PASCAL - A high level language developed by Niklaus K Wirth and named after Blaise Pascal.

PILOT - Programmed Inquiry, Learning or Teaching, a computer program for teachers.

Prolog - Programming in Logic

Program - A set of sequential instructions written in a programming language telling the computer to do a job.

Response - The reaction from the receiver or a medium.

Software - The programs, routines, or instructions that allow the computer to perform tasks.

Stimulus - A point which starts up or stimulates learning and/or teaching process.

Target - The expected participants to be covered by a course.

LIST OF ILLUSTRATIONS

Sr no.	<u>Annexures</u>
1.	2.1 Age profile of Indian ship's
2.	2.2 Projections of trade in Indian ports
3.	3.1 SCI organisation chart
4.	5.1 Target population- shore personnel
5.	5.2 Structure of ship staff
6.	5.3 Entry level shore cadre
7.	5.4 Entry level ship staff
8.	5.5 Domain of cognitive skills
9.	5.6 Target strength of SCI
10.	6.1 Ship design & ship bldg flow
11.	6.2 CAD process
12.	6.3 Ship management functions
13.	6.4 Shipping company operations
14.	6.5 Management information systems in shipping
15.	6.6 Division-wise computer applications in SCI
16.	7.1 History of computers in education
17.	7.2 Computerised training systems
18.	7.3 Human information processing model
19.	7.4 Socratic method of tutoring
20.	7.5 Typical CMI structure
21.	7.6 Example of computer network
22.	7.7 Q-A model of CAI
23.	8.1 A simulation engineering model
24.	8.2 Simulation ladder
25.	8.3 Simulation model in shipping
26.	8.4 Interactive K. B. tutoring
27.	8.5 Elements of an Expert System
28.	8.6 Heuristic structure of ES
29.	8.7 Idiot's Bayes
30.	9.1 Educational computing resources

Figures

- 31. 1.1 Ship types over years
- 32. 6.1 Buxton's design spiral
- 33. 6.2 Shipboard computer system
- 34. 6.3 Computer aided ship loading procedure
- 35. 6.4 Telematic network
- 36. 6.5 Ship-shore communication system

Graphs

- 37. 2.1 Growth of Indian shipping
- 38. 3.1 Growth of SCI
- 39. 3.2 Shipwise growth in SCI
- 40. 5.1 Wastage & recruitment projections- Engr.
officers
- 41. 5.2 Wastage & recruitment projections-Deck officers
- 42. 5.3 Wastage & recruitment projections- non
promotional officers
- 43. 5.4 Wastage & recruitment projections- petty
officers

INTELLIGENT TRAINING TECHNIQUES
THROUGH
COMPUTER BASED SYSTEMS

Abstract.

Computers have gained inevitable access to the marine industry. Modern ships and shore offices are fitted with computers in order to improve efficiency and enhance safety. Tomorrow could be a day of more automation, more computerization and sophistication in shipping.

But what about the man, who man these hightech ships? What about the man who manages these ships in the highly competitive market? He must also be hitech. Hence there is a need for training the people in order to match them with the new systems. In computers we have an excellent tool for training them. Further, simulation techniques and Expert Systems would assist them towards much lower uncertainties and higher performance abilities.

This thesis is a systematic approach to the need of computer based education in the maritime industry and specific to the Shipping Corporation of India ltd. This thesis projects the need for computerization, computer literacy and the need for creating a new breed of mariners.

The chapters are divided in such a way that each particular field is studied separately. Starting with the study of SCI organization, the thesis goes to the computerized education systems, simulator techniques and use of the expert systems. While doing so, it passes through the analysis of target population and the field of computer application in shipping.

INTRODUCTION

The demand for transportation by sea is more onerous than for any other mode of transportation. The ships are subjected to wide variations of loading, weather and other environmental effects. International events prominently control the demand and supply of ships. Political activities in the world alter the shipping scenario so much that the element of unpredictability is very high. The ship and the sailor who mans and manages the ship definitely deserve better compliments from all sides.

The historical advance in ship technology is interesting to see. In the beginning, powered by sails and controlled by pure human skills, the ship could transport goods, from one port to another. Then the era of steam power dawned around the 1850s, resulting in division of tasks between the so called Engineering and Deck officers. Yet another major development was the introduction of diesel engines by Rudolf Diesel in 1898. Then the communication revolution around 1900s brought about major changes to the shipping industry.

As vessels grew in size, and as diversification into different types of vessels came into vogue, ship design and ship operation became more and more sophisticated. Developments in science and technology propelled the systems in shipping to take quantum jumps. Fig 1.1 depicts the diversification of ship types over the years.

After initial hesitation, computers have gained inevitable access to the marine industry. With the inherent qualities of high speed and accuracy, these machines started

displacing men from most of their functions. Modern ships are fitted with computers which are linked to the shore offices for better co-ordination and control. The ships have thus become HITECH.

All these developments throw up a number of questions: What about the men who man these hightech vessels? What about those who manage these ships in the highly competitive world market? How good are their technical skills and their capabilities? Definitely these men must be able to cope with the technological developments, and this is possible only by training them. There is a need for updating their knowledge so as to keep abreast of the new technology.

In computers, we have a powerful tool for training them. Complementary to it are systems of simulation and the use of Expert Systems. These systems, if effectively used in modifying the training techniques, could bring about a reduction in uncertainties and an increase in performance capabilities.

With these in mind, we examine the various possibilities of training techniques and the ways to develop them more efficiently. Even though there is an increased tendency to cut out MAN by including more and more intelligent machines, it may become impossible to totally eliminate him. Man will therefore continue to remain in the scene but would require training and updation in order to work in such altered situations. What would be the situation tomorrow and how it would affect us would be interesting to watch. As we go along, the involvement of the human factor also needs to be considered.

There is a wide spectrum of people on board as well as

ashore who are to be trained in these modern techniques. This training needs to be developed at various levels of expertise, namely operator level, consultation level, manager level and even in the programming level. Knowledge based systems allow us to achieve this at a faster pace.

The Indian shipping scene is no different from those of other countries worldwide. Most of the major shipping companies are operating with ships equipped with highly sophisticated equipment. Shipping Corporation of India (SCI), a Government of India Enterprise from its inception in 1961, grew rapidly to become the biggest shipping company in India. It now owns and operates a diversified fleet of more than 128 ships including hitech scientific research vessels. The SCI caters to different needs of the Indian maritime industry. The growth was too fast for the manpower development to keep pace with, as is the situation worldwide. This resulted in extremely heavy demand in training requirements and a need to provide the required manpower quickly. Most of the institutions concentrated their efforts in pre-sea training in the normal way, with the sole objective of turning out trained men in quantities. Little or no importance was given to the quality of training. This was mainly due to:

- a. Pressure from the industry to fill up vacancies caused by the migration of Indian officers to foreign fleets.
- b. Shortage of time to cope with the commercial needs.
- c. The existing qualifications required by the national law stagnating at the old level to a certain extent.
- d. Lack of modern training equipment tailored to one's

requirement.

- e. Unduely long time required to procure suitable training equipment.
- f. The financial constraints, especially due to the recession in shipping.

Shipping Corporation of India is at present, also affected by a massive manpower shortage. The ships are manned with a minimum number of officers as per the legal requirements. In addition to this, the officers have to serve for longer periods on board the vessels, due to non-availability of suitable relievers. This could result in physical and psychological pressures on the ship staff, which in turn, could affect the ship operation; maintenance and safety adversely, in the following ways:

- 1.0 lack of proper surveillance,
- 2.0 negligence to operations,
- 3.0 personnel conflicts and
- 4.0 reduced overall performance.

A better equipped ship could be operated with low manpower. Norway's project of an 11 man crew has so far proved to be satisfactory though the initial capital outlay is high.

These factors call for better trained crew who could look after the ship's operation more efficiently with the help of computers. The computers can also be programmed as self regulating systems. Training in computers has become extremely essential for a shipping organization. But there is no single institution which could provide such training. A better way would be to develop in-house facilities.

Shipping Corporation of India, a pioneer in every way, established a full fledged training institute in 1978, with the existing training department taking over the training needs of not only SCI, but also the nation. The Institution which is fully operational at present, also trains maritime personnel from other countries, also in various fields.

The SCI started computerisation in a modest way with a 2nd generation computer mainly for automating the accounting procedures. Later SCI went for a 4th generation computer with extensive networking facility. The IBM mainframe computer which has been installed recently is now fully operational. It is capable of supporting communication protocols with shipboard computer local area networks through satellites. When fully implemented, the system will integrate all the shore offices of SCI world wide and also the ships in the fleet.

In addition to the other training needs in computers, the introduction of this computer also required quicker training of all concerned. Since ships computers are linked to the mainframe computers in the office, the ship's officers also need to be trained in computers.

The task being massive, it was thought that an early start in this regard would be highly beneficial. A pilot project was initiated using hired PCs. This effort has since grown and is anticipated to culminate in a Knowledge Based Tutor System. The use of computer based simulator and Expert Systems is also being planned.

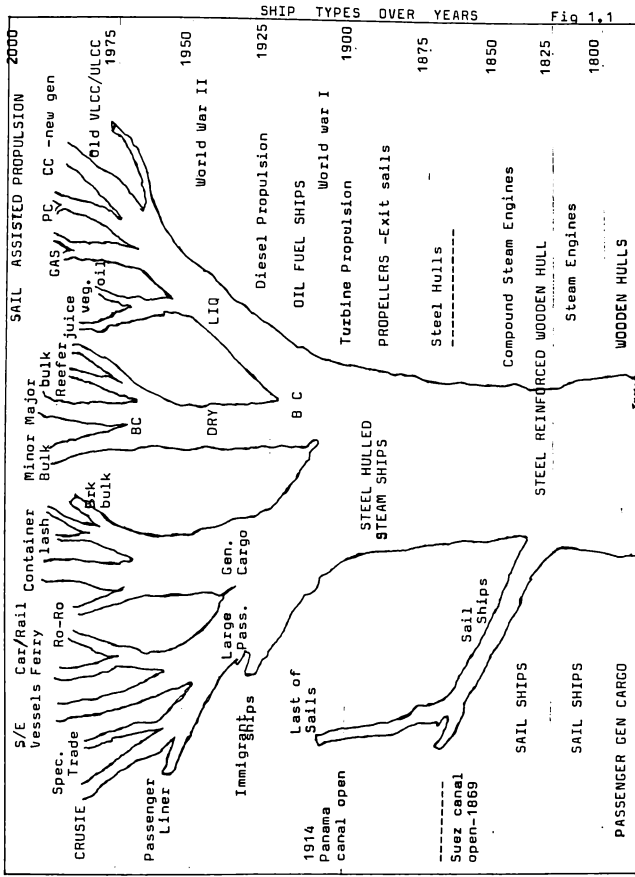

Fig 1.1

SHIP TYPES OVER YEARS

INDIAN SHIPPING - an overview.

India is the second largest country in the world, and has two thirds of the boarder about 6500 km open to the sea. From times immemorial Indian history is connected with its maritime activities. The resources available in India had attracted many nations to link up through trade and transport with India. Though geographically well placed, yet this has its bad points as the country has been invaded by foreign powers repeatedly.

Modern facilities are now available in Indian ports which guarantees faster, safer and efficient cargo movements. Further modernisation by way of upgradation of existing facilities and development of newer ports like Nhava-Seva of Bombay, is on.

The Indian ship building industry being unable to cope with the national needs has compelled India to procure ships from foreign shipyards. It is felt that a large potential is still lying unutilised.

2.1 INDIA, the Nation

India is a country of ancient history and civilization, varied cultures, languages, habits, religion and people. It is renowned for its spiritual and material wealth. History has records of Indian excellence in literature, sculpture, medicine, and science. The valuable "ZERO" was India's contribution to mathematics. Indian Vedas and Upanishads spelled out philosophy in marvellous words. India is a country that must be seen to fully appreciate

its splendour of the Himalayas, beauty of the Taj Mahal, Sculptures of Khajuraho, Ellora and Mahabalipuram, valleys of Kashmir and lush green country side of Kerala.

"Dazzling in its architectural splendour, heart-rendering in its poverty, a mix of modern technology and traditional crafts unchanged for centuries - - - , India today is a land of overwhelming contrasts", is how DNV's managing director Mr. Keith Evans describes India.

Modern India has become self sufficient, in meeting its own need. India now produces and even exports transport vehicles, heavy duty equipment, computers and softwares, garments, tea, spices and many other commodities.

Statistically India has:

Area	= 3,287,590 Sq KM
Population	= 824.91 Million (1986-1989)
GNP	= 260 USDollers
Energy consumption	= 237 kg per person (coal equivalent)
Overall literacy	= 48 %
Gross Domestic Product	= 186,000 Million USD
GDP growth rate	= 5.66 % per year

2.2 THE MARITIME INDUSTRY OF INDIA

India with two thirds of its boarder being coastel waters, has high potential of being a top maritime nation. About 5700 Kilometers of the coast are studded with numerous

ports and are bound by the Arabian Sea, the Indian Ocean and the Bay of Bengal. Indian maritime history began in the earlier years of 3000 B.C. With the enthusiasm and enterprise shown by the people, India remained the mistress of the eastern seas.

In the year 1919, the first Indian ship s.s Loyalty of Scienda Steam Ship Navigation Co sailed from India to UK. During the 18th century, the shipping activities were kept suppressed due to the British rule in India. After independence in 1947, it was a period of foundation laying. During the year 1961 to 1984 Indian shipping tonnage grew up from 1 Million GRT to 6.4 Million GRT.. Shipping Corporation of India contributing a major part.

The major ports of India are Bombay, Calcutta, Madras, Cochin, Visakhapatanam, Haldia, Goa, Tutucorin and Paradip. More than 160 small ports serve the country's coastal trade. The major ports handle exports of the order of 30 million tons and import of 42 million tons. The percentage wise cargo handling is given below:

Imports

Crude oil	28 %
Machinery	11 %
Steel	8 %
Chemicals	7 %

Exports

Crude oil	13 %
Food items, tea	21 %
Iron ore	4 %
Diamonds	10 %
Textiles, fibres	12 %

There are a number of shipping companies in India, both private owned and state owned. The Shipping Corporation of India enjoys the status as the biggest of them, with

a diversified fleet of 130 vessels, over 5 million DWT and earning and saving substantial foreign exchange for the country. Some of the other companies are Great Eastern Shipping Co., Essar Shipping co., South India Shipping Corporation, India Steam Ship Co. and L & T Shipping. The Scindia Steam Navigation Co had the reputation of being the oldest and ten years ago had a fleet of 46 ships, with 875,000 dwt. But the severe economic problems pushed Scindia in 1988 to the verge of bankruptcy. Presently, with the support of the Govt of India, it is limping back to normalcy. The growth of the Shipping companies over the past 30 years is shown in graph 2.1.

The total Indian fleet position in 1988-89 is given below.

Bulk carriers	98 nos
Oil cum bulk carriers	8
Cellular container	1
Dry cargo vessels	101
Miscellaneous	34
Offshore vessels	60
Passenger	7
Tankers	63
Ro-ro ship	1

The total strength is 373 vessels. It is interesting to note that the frequent replacement of old ships, mainly by the SCI, had kept the average age of the Indian fleet very low. The statistics are given in the Annex 2.1.

On the Ship building side there are 4 major ship building yards, 2 on the west coast and 2 on the east coast.

a) Mazagon Dock Ltd, Bombay - Naval ship production

- b) Cochin Shipyard ltd, Cochin - Commercial vessels of Panamax class bulk carriers and others
- c) Hindustan shipyard ltd, Vizag - Commercial vessels
- d) Garden Reach Ship Repair - Naval Ships and commercial vessels

Repair facilities are also available at these yards though not sufficient to cope with the demand.

2.3 PROJECTIONS TOWARDS 2000 AD

A number of areas are identified in order to strengthen the shipping industry for the future. While trying to provide adequate tonnage for the overseas trade, the industry aims to improve its coastal tonnage and trade. Diversification to offshore activities, specialised areas and passenger ships is one of the major projects for the future.

The cargo movement in Indian ports is expected to be increased by around 150% within the next 10 years. The projections of the trade is shown at Annex 2.2. While studying this projection, it may be noted that this regression model is based on the analysis of a number of interactive and fluctuating situations and assumes the oil : GDP elasticity coefficient as 5% to 6% from low to high situations. High value cargo is shrinking in size due to technological innovations and this phenomenon on one side may increase earnings, while on the other side reduce the amount of cargo by tonnage. India's large

reserve of natural gas and other resources is also not considered in the model.

Over the years India has built up a large pool of trained manpower. One of the effects of the excellent training imparted by India to its officers and crew has been the massive outflow of manpower to foreign flag vessels. However the future plans are to introduce gradual reduction of manning levels in newly acquired ships so as to approach International levels. This requires upgradation and enhancement of training facilities for the on float personnel as well as the managerial personnel employed in the shipping sector, in order to exploit the benefits of technology and to improve on the safety of operations.

The planning committee has suggested about 150 crores rupees financial outlay of training for the future.

1. Expansion of Shore based Academy	3.5 Crores
2. Expansion of DMET	3.0
3. Updation with Simulators	50.0
4. Computers & teaching aids	10.0
5. Updation of LBS college	8.5
6. Institute for higher education	15.0
7. Infrastructure	4.4
8. Pre-sea training for crew	19.0
9. Software and teaching material	36.6

GROWTH of INDIAN SHIPPING COMPANIES

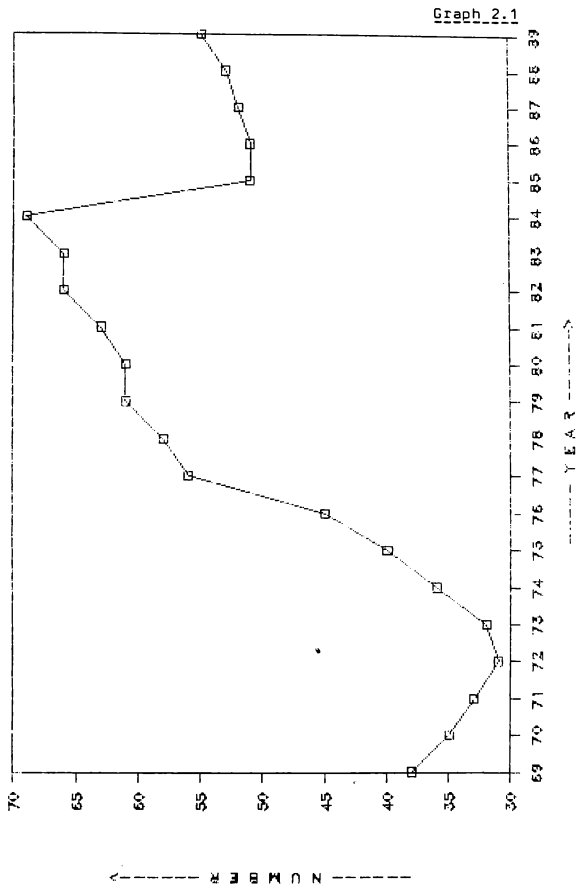

AGE PROFILE OF INDIAN FLEET

Years		Overseas	Coastal	Total
< 5	Number	45	57	102
	GRT-lakh ton	12.36	1.74	14.1
5 to 10	Number	57	60	117
	GRT-lakh ton	9.5	1.20	10.82
10 to 15	Number	75	95	170
	GRT-lakh tons	20.54	0.79	21.10
15 to 20	Number	46	50	96
	GRT-lakh tons	5.44	0.89	7.15
> 20	Number	16	28	44
	GRT-lakh tons	1.90	0.18	2.1
TOTAL	Number	235	139	374
	GRT-lakh tons	50.86	4.62	55

*source . DG shipping Indian tonnage statistics 88-89

PROJECTED CARGO MOVEMENTS in INDIAN PORTS by 2000 AD

Overseas Trade (in Million tons)		85-86	2000	
			Low	High
General cargo	Export	4.4	8.0	8.0
	Import	9.3	11.0	11.0
	Total	13.7	19.0	19.0
Crude oil & products	Export	0.0	0.0	0.0
	Import	19.0	30.7	42.6
	Total	19.0	30.7	42.6
Bulk cargo	Export	28.8	35.1	35.1
	Import	5.7	10.1	10.5
	Total	34.5	45.2	45.6
Total overseas	Export	33.2	43.1	43.1
	Import	38.0	52.2	64.1
	Total	71.2	95.3	107.2

*Source - Indian shipping towards 2000 AD- Planning report

SHIPPING CORPORATION OF INDIA

The Government owned Shipping Corporation of India ltd- (SCI), was established in the year 1961 to serve the country's trade requirements. This was the result of merging 2 public sector shipping companies which were existing at that time. They were the Eastern Shipping Corporation established in 1950 and the Western Shipping Corporation established in 1956. AT the time of inception the fleet strength of SCI was 19 ships aggregating 1.9 lakh dwt and predominating in liner shipping only. On the day of amalgamation, SCI had an authorised capital of Rs. 35 crores and paid up capital of Rs. 23.45 crores.

In June 1966, SCI was appointed by the Government of India to manage the affairs of Jayanthi Shipping Co. ltd. and its 16 vessels. On 17th Oct 1971, shares of Jayanthi Shipping Co. were transferred to SCI and she became a subsidiary of SCI. For the purpose of proper coordination Jayanthi was amalgamated with SCI on 1st Jan 1973. Thus the SCI fleet grew to 93 ships aggregating 11.96 lakh grt. (ie. 18.42 lakh dwt).

On 30th June 1986, yet another Government of India Undertaking, namely the Mogul Lines ltd. with its fleet of 12 ships aggregating 1.51 lakh grt merged with SCI.

The structure of SCI was then reorganised. Three functional divisions were set up called "Profit Centres" looking after the three major services, namely,

1. Liner Services
2. Bulk Carrier and Tanker Services
3. Coastal and Passenger Services.

Each of these was placed under the control of a Joint Managing Director. Three service centres namely Finance, Technical Services and Personnel and Administration were supporting the corporate needs of the organisation. The organisation chart is shown at Annex 3.1.

SCI operates from its head office at Bombay. Regional offices are established at Calcutta and Madras. Branch offices are situated at New Delhi, London, Mombassa and Port Blair. Further, SCI representatives are operating at Cochin, Rameswaram, Haldia, Singapore, Tokyo, New York, Dakha and Port Said. In all the other ports SCI operates through agents.

3.1 OBJECTIVES of SCI

The macro objectives as defined by the policy matters and adopted by SCI are as follows;

- assign an expanding role to Public Sector and envisage its future growth.
- provide infrastructure for economic development and promotion of self reliance.
- serve as part of national security.
- maintain essential foreign trade and promote exports.
- acquire, own and operate ships on commercial basis.
- provide and assist India's international trade in general cargo and bulk commodities like oil/ore.
- generate surpluses from commercial shipping services to a comparable level to other countries.
- maximise and earn foreign exchange.
- develop assistance to public sector enterprises and to the Government of India in the field of

- shipping from time to time.
- operate non-commercial shipping services at the direction of Government of India.

There are a number of micro objectives such as leading a prominent position, to modernise and diversify, to develop ship management expertise etc. One of the micro objectives is to "develop capabilities and to sustain perpetually sound, technical and technological knowledge through proper training of personnel and by giving them suitable exposure" and "rapid development of maritime man power".

3.2 SCI FLEET

Presently SCI owns and operates more than 55% of Indian tonnage. SCI is considered as the bellwether of Indian shipping fortunes with its close to 5 million tonnes and is still growing at a fast rate.

SCI owned & operated ships: Total 130 grt 29,60,000
dwt 49,19,700 -

Overseas Cargo	47	Bulk carrier	25
Combination carrier	3	VLCC	2
Crude oil tankers	19	Product tankers	12
Passenger cargo	8	Timber carrier	1
Off shore vessels	10	Storage vessels	3

Out of the above 30 are container vessels. There are 9 vessels on order. In addition to the above, SCI mans and manages 23 specialised vessels of total grt 54,373 tons. Eight of these are passenger and cargo services vessels. Specialised vessels total 15 and include light house vessels, research vessels, oil exploration vessels, geological survey vessels etc.

The growth of SCI fleet is shown in graph 3.1.

Services include state required social services and other non-profitable obligatory services. SCI is one of the very few companies, which could survive the recession and grow at the same time. The reason for this may be attributed to the good vision of the management and diversification. The average age of the SCI fleet is very low due to the sound decision of management to replace old vessels with new during the recession period.

The shipwise growth of SCI is given in graph 3.2.

3.3 SCI's VISION of THE FUTURE.

SCI has always set its target high to serve the nation. To achieve this, the future plans thought of are to diversify on the one side and on the other side to achieve technical excellence through sound manpower development. As a part of the growth programme, SCI plans to concentrate in many areas. Some of these are given below;

- diversification into specialised areas like internal container depot (ICD), managing these depots, containerisation etc.
- acquiring special ships like acid carriers, LPG and LNG carriers, Chemical carriers, etc.
- strengthen offshore fleet with multi support vessels.
- provide management and consultancy services .
- strengthening of the training needs of all employees.
- computerisation and training in computers.

THE SHIPPING CORPORATION OF INDIA LTD ORGANISATION CHART

ANNEX 3.1

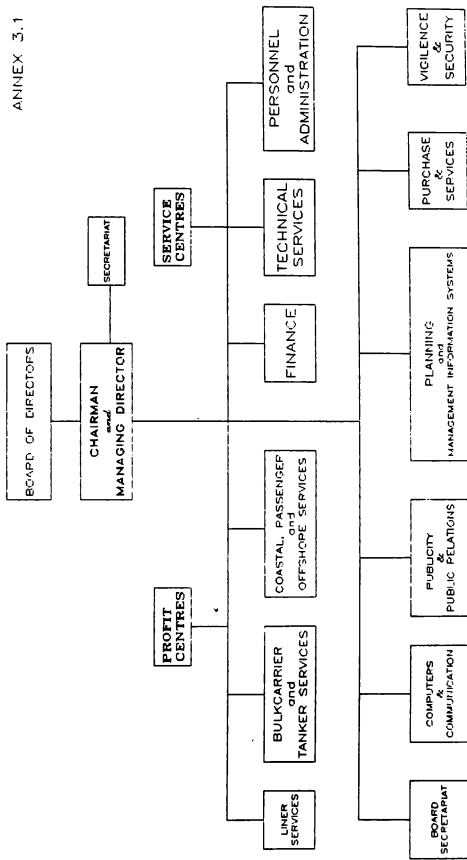

GROWTH OF SCI FLEET

(excluding OBO/OSV/OTHER MANAGED VSUS)

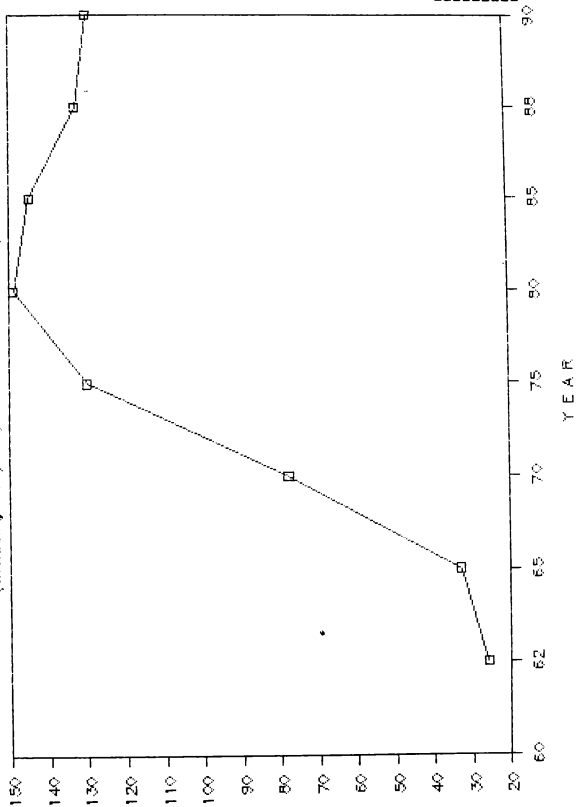

NUMBER OF SHIPS

SHIPWISE GROWTH of SCI FLEET

Graph 3.2

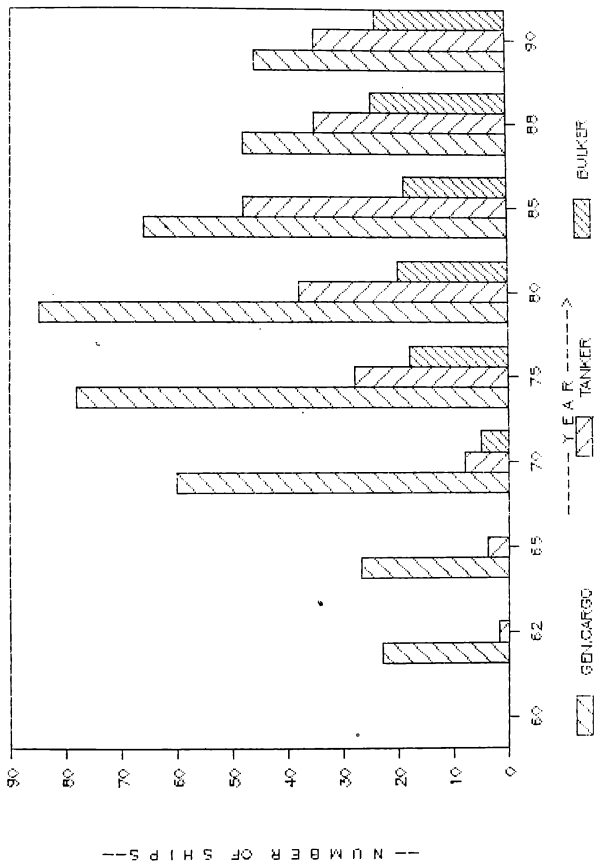

**MARITIME TRAINING INSTITUTE
of SCI.**

The Shipping Corporation of India established its training department in 1973 with the main objective of training shipboard personnel in ships automation and control systems. The first category of officers to get trained was the engineers. Gradually a course on Mid-term training for the cadets who were to appear for the 2nd Mates' examination, was introduced along with the Radar Observer's course. As years rolled by, the need for a full fledged training establishment was felt. The project for a training establishment was soon conceived and implemented by setting up the Maritime Training Institute (MTI) at Powai, Bombay. No other shipping company in the world is known to have set up a training institution of such a magnitude and dimension as the SCI.

Situated in the picturesque surroundings of a holiday spot and spread over 45 acres of land, the MTI has its own Planatorium, Auditorium, Academic Block, Administrative block and Hostels for officers, petty officers and crew and cadets. Its fire fighting complex contains a ship-shape mock up model where actual fires are fought by trainees under expert supervision. The campus includes living apartments for MTI faculty, officers and staff.

Administratively, MTI functions under the Personnel and Administration division of the SCI, and the day to day operations are carried out under the supervision of a full time Director.

The MTI has already achieved the distinction of being a branch of the World Maritime University, Malmo, Sweden. A number of international seminars have already been conducted at the MTI. A number of IMO seminars and model courses are also conducted at the MTI. Recently, the TRAINMAR/UNCTAD project has also shown interest in making MTI a centre for its activities and soon agreements to this effect will be signed.

4.1. Existing Programmes.

The main programmes which are conducted at the MTI can be broadly classified into 5 categories:

- a) Basic training at the induction level.
- b) Updating skills and knowledge in view of technological changes.
- c) All mandatory courses as per the STCW convention 1978.
- d) Developments of managerial skills.
- e) Improving human relations and communications.

Some of the courses are meant only for SCI personnel at all levels including fleet personnel and shore staff. Other courses are open to all. SCI has already trained a number of officers from other shipping companies, from Port Trusts, Nautical Colleges, Shipyards, Oil Companies, Classification Societies, Government Maritime Administration officers and surveyors.

The MTI has also developed tailor made courses for other

institutions like the "Tanker Terminal Operation and Management" course developed for the Indian Institute of Port Management, Calcutta and "Tanker safety operations" for the Indian Oil Corporation.

The Current Programmes are as follows:

1. Navigation Cadet Officers' training course.
2. Engineering Cadet Officers' training course.
3. Basic Tanker Safety course for Petty Officers.
4. Basic Tanker Safety course for crew.
5. Basic Tanker Safety course for junior officers.
6. Specialised Tanker Safety course for senior officers.
7. Marine Control Engineering course for Engineers.
8. Chief Officer's Orientation course.
9. Second Engineer Officer's Orientation course.
10. Basic Fire Fighting course.
11. Advanced Fire Fighting course.
12. Basic Survival at Sea course.
13. Mid-term course for cadets.
14. Radar Observer's course.
15. Assistant Pumpman's course.
16. Assistant catering officer's course.
17. Shipboard Management course.
18. Management Development course.
19. Finance for Non-finance Officers course.
20. General Shipping Management course for staff.
21. General Shipping Management course for officers.
22. Cost Control in Shipping Management course.
23. Containerised Shipping Management course.
24. Computer Appreciation course.
25. Marine Hydraulic course.

Besides the above courses, there are a number of courses

conducted as per the needs. e.g. MAN Engine Course, Hagglund Hydraulic Crane course, BLM Crane course, SAAB Marine Tank Gauging course etc.,

A large number of officers and staff are also sent to attend courses outside MTI for general subjects. The seminars and IMO courses which are conducted frequently at the MTI are not included in the above list.

Presently some of the courses like welding are conducted through outside agencies at their premises until the facilities are developed at MTI.

Depending on the demand for the courses, and availability of suitable participants, the courses are sometimes re-scheduled.

4.2 Proposed Programmes.

In addition to the existing programmes a number of additional programmes are proposed for the consideration of the SCI management, for the future.

1. Computer courses for shore personnel *
2. Computer courses for ships' staff*
3. Simulator courses for ships' staff*
4. Course in Human Relations for shore personnel
5. Course in Human Relations for ships' staff
6. Post Graduate courses in Nautical science/ maritime affairs etc.
7. Doctoral programmes in various faculties.
8. Degree courses in Maritime law, Maritime safety, Maritime Administration, Shipping Management.
9. Management courses and other special courses like

Training for Trainers, Course development, Public speaking, memory workshops etc

10. Chemical Tanker course.
11. Gas carrier course
12. Dangerous cargo course.
13. Courses in CAI & CMI.*

The courses mentioned above with * mark are discussed as part of this thesis in the following chapters.

Some of the courses like Computer Managed Instructions (CMI) and Computer Assisted Instructions (CAI) would also form a part of faculty development programmes, though these could also be catered to others. In addition the following points may be considered for the development of the faculty.

- a. to nominate and send one of the faculty members each year for training at the WMU, Malmo.
- b. to nominate the faculty for relevant national and international seminars and conferences.
- c. to encourage the faculty to write and present technical papers.
- d. to conduct courses like public speaking, personality development, lecturing techniques etc.

While considering the above proposals it may also be noted that considerable interest must be taken to improve the physical facilities like the library, research facilities, course material production room, workshops, simulators and laboratories.

POPULATION ANALYSIS

Modern ships and the new systems of integrated controls are not creations of a single day. It has taken considerable time to conceive the ideas, design them, test them, modify them and later put them into operation. The problem then was manpower development, which was not developed at the same pace till the systems came into operation.

Hence if we are planning to update manpower by proper training and education, it is not only important to train them for today but also for tomorrow. This would avoid the crisis which seems to frequent the shipping industry.

Training for tomorrow's ships would definitely require training personnel in computers. But the planning of training courses should be done intelligently. Only then can we achieve the objectives. Along with the objectives, aims and planning of the courses, a study of the most important element in the system must also be carried out. That is to study the 'participants'.

Before we go into that study, let us set our objectives clearly and see how we can do it. Then we can go into the examination of the background of expected participants to the proposed and existing courses in computers, ie, the study of the target population.

5.1 A discussion of the objectives.

Designing a course is not just collection of documents of what to teach, what things are required for teaching, what

is to be prepared or just making a course curriculum. He who designs the course must set his objectives and aims properly and orderly, as the first task.

Objectives are defined in many ways. Blishen (1969) defines it as, "Objectives tell the participants, what the minimum level of acceptance for his or her eventual performance is to be, and under what conditions it will be achieved. To be meaningful, any statements of objectives must specify observable, preferably measurable, changes in the learners behaviour at the end of the course".

Some points mentioned by Dawes (1972) are worth looking into at this juncture; that the students must be able to:

- identify the resources.
- use the resources wisely.
- choose between, conserve, exploit or economise on the resources.

Further to his comments, we may add the following;

- recognise need, result and responses of actions.
- perform the tasks within the time limits.
- show positive attitudes.
- improve the existing capabilities.
- learn while performing the tasks to add to his previous levels of performance.
- and set the aims in a specific order.

Aims are the starting points. They are ideal; an aspiration, a direction in which to go. They are visionary in character, and therefore, in a very real sense, unreal.

-Davies(1976)

Objectives and aims could create confusion, since there is

no specific barrier in between. Some times we could use the metaphors developed by theoreticians. For example Davies classifies "aim" as starting point and direction and "objectives" as the milestones achieved and to be achieved.

Even after setting the objectives clearly, we must remember that these are only "ours". The student still has the choices on what he could learn, how much he could learn, and how much he could and would use later. This puts more importance in studying the background of the students before designing the course.

Motivational techniques put more stress on a direct interacting type of training. CAI- CBI are on top of that list. It makes the student to be the 'performer' rather than remaining as one in the 'audience'.

After knowing objectives and setting the priorities correctly, the course designer is now in a good position to study the target to which he is aiming the course. Some of the basic questions he must ask himself and find answers to are listed below.

- Who are the beneficiaries of the course?
- How much do they already know?
- How much more do they require to be taught?
- What method is to be selected?
- How much is the time available for information transfer?
- What are the resources available to him?
- Is the technical expertise available elsewhere?
- What would be the course group composition?
- Where and when can he conduct the course?
- and What are the main objective of the course?

Most of the above questions would pertain to the target population at which he is aiming the course.

Effective methods of course development would have to start with the analysis of the **Knowledge, Skills and Abilities** of the trainee. Educationalists call this in many ways such as **KAS, KSA or ASK**. These three form the triangle of target assessment. The classification as per Prien is given below.

Knowledge is the foundation upon which abilities and skills are built. Knowledge refers to an organised body of information usually of a factual or procedural nature, which, if applied makes adequate job performance possible, (though possession of knowledge does not guarantee that it will be used properly).

Skill refers to the capacity to perform job operations with ease and precision; mainly referring to the psychomotor type of activities.

Ability refers to the cognitive capabilities for doing the job skillfully.

Some of the academicians call these Knowledge, Skill and Ability. I would rather call these **Knowledge, Skill and Attitude or Aptitude**, since the ability could be included in the skill. If a man is skillful, he has to be able to perform the task to the prescribed standards.

When we are discussing the KSA of the target it should not be forgotten that they are equally important in the case of course developers as well as the course delivery team.

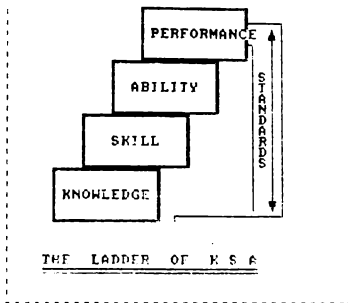

5.2 Who is he?

The target population includes two major classes of employees in SCI, the present employees and the new recruits. Further they could be divided into fleet personnel and shore personnel.

In this thesis, only those who are directly involved in computer applications and thus are going to be trained in computers are discussed. Others, for example the ship's crew may not require any training in computers at this time. For information purposes, we could add a short lecture in some of the crew training courses.

The present employees could be graded according to their level of understanding of the subject. But when it comes to the new entrants even people with similar qualifications, but from different universities may know different things. So we have to know 'where they begin not to know' and their preferred ways of learning.

This is part of the objective setting area, and now we can examine K.A.S aspects of our participant. The success of the programme would depend on this. In shipping it is very easy to get a single course group in which the participants are widely differing in age, background, experience, languages and in motivational or interest aspects. This makes the job a bit more difficult and at the same time more challenging.

"First and perhaps the bluntest approach is to restrict the entrance of unsuitable students to the course by refusing to enrol those deemed to have insufficient qualifications", says Allen H. Miller (1987), but then what is the measure of qualifications? As was mentioned earlier, is it only the certificates or the experience or any thing else?

In shipping, restricting the entrance is not very easy. One reason is the difficulty of assessing the participant prior to the entry to the course. For example, in the case of a Master or Chief Engineer, we have to assume that he knows or rather is supposed to know, most of the things about practical ship operation. There again, wide gaps do exist. One may be extremely good while another with the same stripes on his shoulders could be on a much lower level. The present data base is inadequate for proper prediction of the participants' KASs.

A diagnostic test at the entry level could be a solution. But in shipping it is very difficult to refuse the participant and reject him, since the company has already called him from his home town and paid heavily for his flight and stay arrangements. However, there is a great advantage in these diagnostic pre-tests that it gives the faculty a fair idea of which areas to concentrate on and which areas to skip. This could further be beneficial in the quantum transfer of information, though it may need on-the-spot adjustments with the delivery of the course.

Some of the main characteristics needed for population analysis are;

- age profile,
- basic qualification,
- present level of responsibilities,
- previous records of performance,
- intellectual factors,
- physical conditions like health, eye sight etc.,
- barriers of communication, if any, like language,
- personality factors.

Once the study of the participant is completed, the next area can be analysed. That is to answer the question of what you want the trainee to achieve as a result of this training. We had discussed the objectives in general. These objectives or the domains of achievement in an instructional system can be summarised into the following three categories.

1. The cognitive domain- knowledge and mental skills
2. The social domain- status, feelings, aptitudes, etc.,
3. The psychomotor domain- physical skills

As far as the shore staff is concerned the main domains are the first two. For the ship staff, they must achieve all three domains. This could be done through different courses. To a certain extent all three domains do interact with each other, though in some case the priorities are listed differently.

Whether it is training or a normal work situation or while transferring any information, the cognitive ability is of higher value. Anastasi (1968) describes the cognitive ability as "mental ability that reflects cumulative influence of non-specific life experiences". It is distinguished from achievement, which refers to the customs of specific learning experiences as opposed to the potential.

H.S. Osborn, in his paper "Design of selection and training systems," has nicely summed up the branches of cognitive ability as given in the Annex 5.5.

Depending on the cognitive skills of personal and depending on which domain is to be developed, the courses can be planned in any one of the three levels.

1. Surface level courses- giving an abstract knowledge.
2. Medium absorbant level courses- where some of the 7 marks are answered.
3. Deep level courses- where no 7 marks are left unanswered.

A knowledge of the above categories would assist the course designer in achieving the desired results. The delivery team could modify the teaching methods so as to suit each of the individuals.

5.3 Assessment of SCI population

SCI population can be broadly divided into "Ship staff" and "Shore staff". Before specific courses are planned each of the group will have to be examined.

The target population of SCI shore staff is shown in attached Annex 5.1 and of SCI fleet personal in Annex 5.2

Each of them have totally different K, S and As, and the instructional strategies would need modifications to suit the group. In order to design the course content properly a study into their background is a must.

5.3.1 Background study of the shore staff.

Annex 5.3 shows the entry level requirement of the shore personnel.

The staff level joins either with some basic education at school level or with some experience with the work.

Coming to the level of Junior Officers the entry is after graduation or even after taking a degree in Business Administration or Chartered accountancy. Some of the Junior engineers or deck officers who have not reached the level of Chief Engineer or Master may also join as JOs.

At the manager level, especially in the technical side, the entry is from the ship staff. After 3 to 4 years experience in the rank of Master or Chief Engineer they may be selected to the manager level in the office.

5.3.2 Background study of the Ship's Staff

The typical entry level structure on board ships is shown in annex 5.4.

Most of the deck officers start their career as a cadet after their basic schooling and intermediate, ie, 10 + 2 years before joining the T.S. Rajendra (the training ship). After completion of 2 years at the training ship, they join the ship as cadets for 3 years. After this period they could appear for the examination. On passing the examination they can join back as a fourth officer. Then the growth depends on completion of the necessary sea time for the examinations and on the decision of the management. Further they could rise to the rank of master.

The Engineer officers start their career after the 10 + 2 basic education, by joining the T:S: Rajendra as an engineer cadet or by joining the Directorate of Marine Engineering Training (DMET). After 4 years of training they join as fifth engineer on board. Yet another way of entry is to undergo four years to five years training at any reputed marine workshop or ship yard. Then the growth is similar to the deck officers ie, completion of the sea time, passing the appropriate examinations and getting promoted to a level of a chief engineer on board.

During 1970s SCI had taken a wise decision to induct engineering graduates of the mechanical or electrical discipline as trainee marine engineers. After a formal training of 10 to 12 months in a shipyard or a marine workshop or a port trust they are posted on board as a fifth engineer. Later even the DMET had opted for this programme.

Recently SCI has taken one more step ahead by inducting graduates as nautical cadet officers. After a rigorous training of 4 months they could join the vessel as cadets.

Once they reach the rank of chief engineer or master and serve on board the ships for a minimum of 3 years, the management may promote them to the shore cadre as Manager.

Electrical officers in SCI are mainly selected from naval officers, who have had at least 15 years of experience in any of the related areas. They could also come as direct entry if they have 10 year basic experience after a diploma in electrical trade or 4 years trade apprentice-ship in electrical engineering. Some of the wireman with sufficient experience and who have proved worthy may also get promoted to the level of electrical officers.

Now let us come to the controversial side of radio officers. The radio side begins with basic schooling of 10 years and receiving a Radio Officer's certificate from a recognised institution. This course is normally of 2 to 3 years. He then joins as a Trainee Radio Officer and gets his confirmation as Jr. Radio Officer within 6 to 12 months.

In the olden days the entire long distance communication system depended on this individual and his capabilities of correctly identifying the Tl-Ta-Tl-Tis and sending them efficiently. Then shortly the VHF and RTI came in. But now the good old system of communication through Morse code is being replaced with modern satellite systems. Entry of Digital Selective Calling, GMDSS (Global Maritime Distress and Safety System) and SATCOMs are posing a grave danger to the existence of the radio officers. Many companies are

thinking of what to do with this category. Some companies are planning to train the existing radio officers in the field of electronic maintenance and computers.

In SCI, the ships acquired after 1983 are all fitted with SATCOM and SATNAV systems. There is a steady process implemented to replace old systems with modern systems in other vessels. This would definitely necessitate reorientation of the radio officer towards an electronic maintenance officer by proper training so he could then look after the computerised systems to certain extent.

Another opening to the ship job is as an Immigration Clerk. After graduation and with 2 to 3 years experience in clerical work, he could join as an immigration clerk. Knowledge of typing and accountancy would be added assets. Within two years he could be promoted to the level of the purser on board. These categories fall under potential target to computer courses because of their job of book keeping, salary, victualling, and other secretarial work.

Catering officers join the ship as Asst Catering officers after the intermediate and 2 year diploma course in 'Catering technology and Hotel management', and with 2 to 3 years experience. In some cases the general steward or the pantry man with 3 to 4 years experience also can be promoted as the chief steward. The job of the chief steward is the same as that of the catering officer. He has to keep the records of victualling and maintain a good inventory control. His job could be tough on board a passenger ship and knowledge of computers in information upkeep would be advantageous for him.

While analysing the annexes 5.3 and 5.4 with respect to the

entry level situations, one may note that there is nowhere in the line a specific input on computer education. A few personnel may have taken up computer subjects purely on personal interest and may know something about the computer and its applications, but not sufficient to ensure safe operation of the computer and computerised systems. Hence it is imperative that suitable courses are designed to train them in the relevant areas.

5.3.4 Population Census

The population mass in SCI alone is quite a large one, though these courses can be catered for the outside candidates also. As on 1.1.90 the SCI strength is given in Annex 5.6. The categories not considered presently as a potential target are not shown in the annex.

5.4 Influencing Factors

A number of external factors influence the population target. Some of these factors are given below.

1. Acquisition of new ships
2. Diversification of activities.
3. Industry wastage.
4. Internal promotions.
5. Entry of new computerised systems.

SCI plans to keep their fleet young and healthy by timely investments in new ships and scrapping the aged ones. Some of the vessels are scrapped before completion of the expected life span of 20 years due to techno-economic reasons. Within the next five years SCI plans to scrap about 11 liner vessels, 5 bulk carriers, 4 of its

combination carriers, the 2 VLCCs, 7 of the Crude carriers, 7 of the product carriers and 4 of the passenger/cargo ships. The scrapping programme will be in a phased manner with newer ships entering at the same time.

Further to the replacement programme, tonnage expansion also would be under taken. All new vessels are expected to have more sophisticated computerised systems and would therefore require highly trained staff to operate.

SCI's future plans are mentioned in Chapter 2. Just to recapitulate; few of the plans are the ICD management, ship management, offshore operations and fleet management. In this field also use of computerised systems will be at an increase, needing a higher amount of training.

SCI faces a high rate of wastage of personnel. A large percentage leaves for better financial gains by taking up job with foreign companies. Hence recruitments and training has to be kept at the same pace in order to avoid crisis of manpower at all situations. The projected manpower wastage and recruitment pattern for the next five years is shown in graph 5.1. This again does not include the high drain of man power during the high demand periods. In addition to the wastage, the internal promotions would necessitate training of the personnel in the new ranks.

As far as computerisation is concerned, it is a very crucial time for SCI. The rate at which computerisation is going on is very fast. In order to utilise the full capabilities of the computers all data and information has to be fed in as fast as possible. The data entry must be correctly done. Checking and rechecking must be done to ensure that nothing is omitted or done wrongly. If not,

the results would be disastrous and the 'GIGO' effect would take over.

These external influences need to be smoothed out. Then only we could get the efficient output from these modern machines. The only way to achieve is to train the people and make them understand the good side as well as the bad side of computers. They must appreciate the capabilities and the limitation of computers before they could work with them confidently.

Now as a word of caution, it is not advisable to give the computer operations to some one who thinks that he could do it without any training. It is like a new toy now, and a fascinating one too. The tendency would be to press a few buttons and see what happens. The result would be erasing of important data or the adding of unwanted data. It would be advisable to train them, even if they know something about computers.

-----o-----

SHORE PERSONNEL CHART

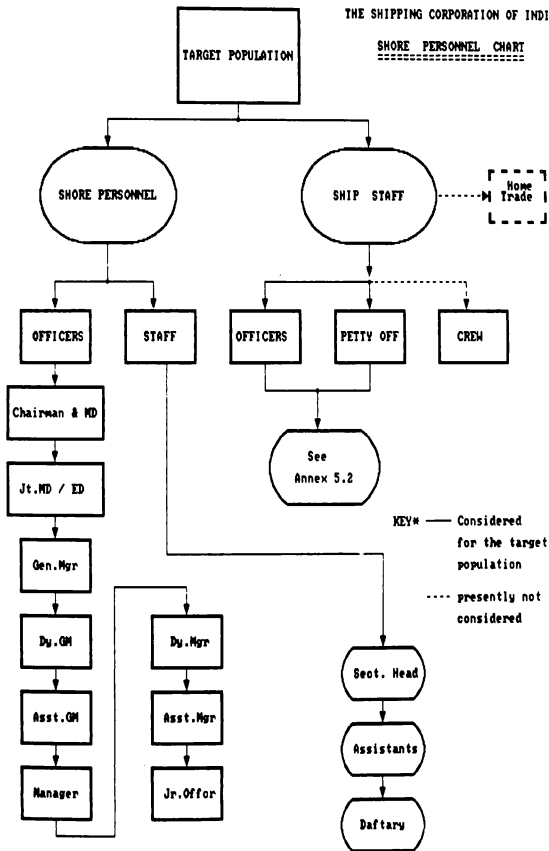

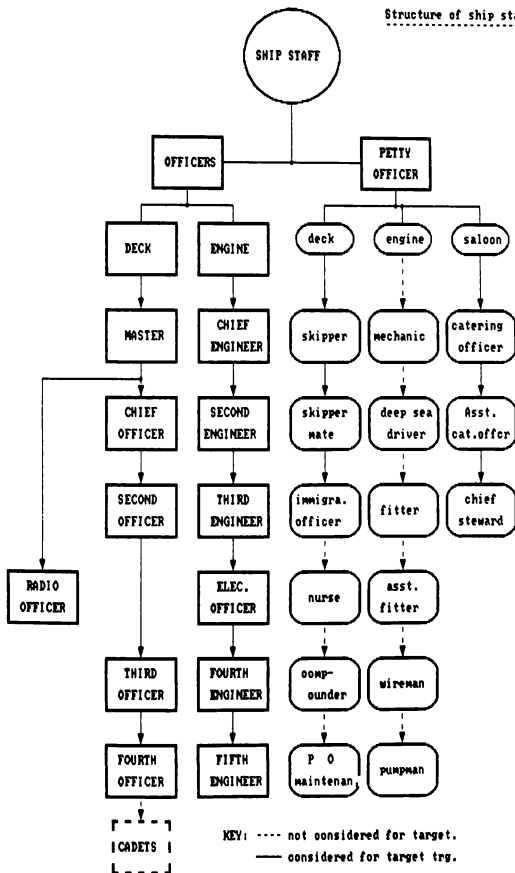

THE SHIPPING CORPORATION OF INDIA LTD

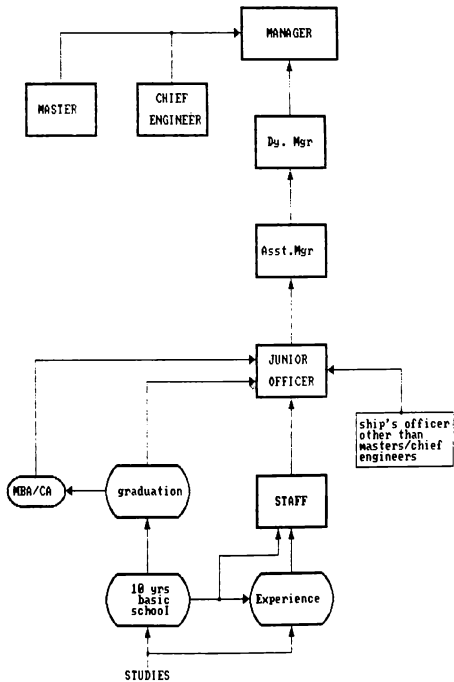
ENTRY LEVEL AT SHORE CADRE

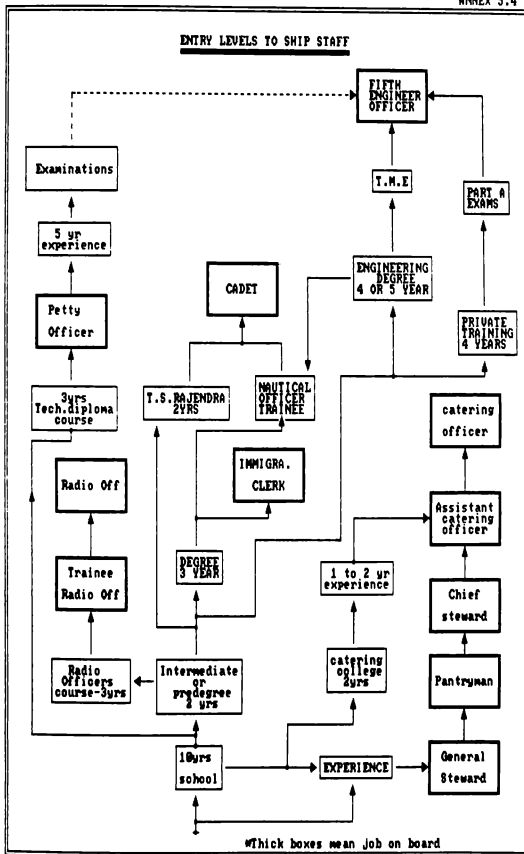

DOMAIN OF COGNITIVE SKILLS

- a. **General Mental Ability.** The ability to understand verb and numerical concepts, underlying principles, and the ability to reason or solve problems requiring the perception and understanding of relationships among abstract patterns or symbols. Tests classified as general mental ability contain a combination of any verbal, quantitative, and either reasoning or spatial ability item types.
 - b. **Verbal Ability.** The ability to comprehend and use language effectively and correctly. Cognitive tests containing reading comprehension, vocabulary, grammar, spelling word fluency, sentence completion, and/or any combination of these tests.
 - c. **Quantitative Ability.** The ability to understand numerical relationships and concepts and to perform routine arithmetic operations quickly and accurately.
 - d. **Reasoning Ability.** The ability to think logically and clearly in factual, symbolic, or figural term, the ability to understand and apply the underlying principle or to draw correct conclusions or make good decisions from stated conditions or information.
 - e. **Perpetual Speed.** The ability to perceive pertinent detail quickly and accurately in verbal, numerical, pictorial, or graphic material; all measures of this ability are speeded.
 - f. **Memory.** The ability to learn, recall, and reproduce or apply visually or orally presented information or associations among verbal, numerical, or figural stimuli.
 - g. **Spatial/Mechanical Ability.** The ability accurately to perceive or to visualize and manipulate mentally spatial patterns and relationships or the orientation and movement of objects in space and ability to understand and apply simple physical and mechanical principles.
 - h. **General Clerical Ability.** The ability to perform tasks of a general clerical nature which require a basic facility with verbal or numerical material and the ability quickly to perceive detail such material.
-

Target strength in SCI

Shore Personnel:	Chairman & Mang. Director	- 1	
	Joint Mang. Director	- 2	
	Executive Directors	- 3	
	Officer on Sp. Duty	- 1	
	General Managers	- 20	
	Div. Gen. Managers	- 84	
	Asst. Gen. Managers	- 90	
	Masters	- 150	
	Div. Managers	- 707	
	Head. Managers	- 106	
	Junior Officers	- 373	
	Staff	-	
Fleet Personnel:			
	Masters	- 247	Chief Engineers - 23
	Chief Officers	- 190	Second Engineers - 78
	Second Officers	- 214	Third Engineers - 16
	Third Officers	- 14 (HT)	Fourth Engineers - 54
	Fourth Officers	- 1 (HT)	Fifth Engineers - 41
	Radio Officers	- 197	
	Purser/Imm. Clerk	- 199	Machinician - 218
	P.O. Maintenance	- 171	Ass. Machinician - 152
	Cat. Officer/Cn. Steward	- 212	Wireman - 181

WASTAGE & RECRUITMENT PROJECTIONS
[ENGINEER OFFICERS]

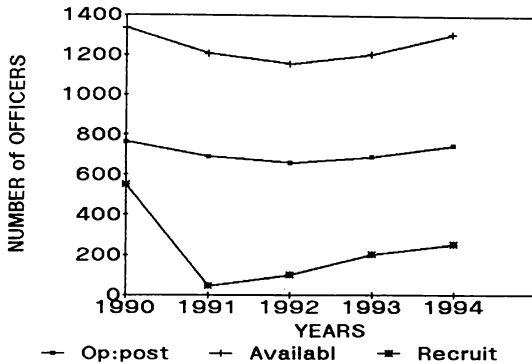

WASTAGE & RECRUITMENT PROJECTIONS
[DECK OFFICERS]

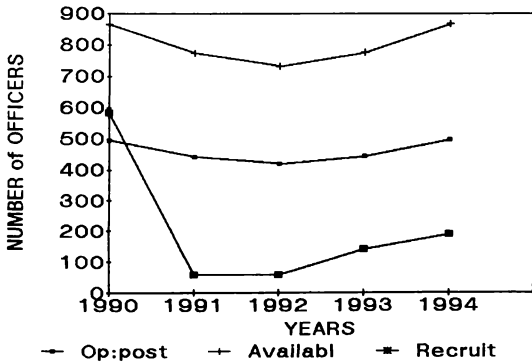

**WASTAGE & RECRUITMENT PROJECTIONS
[NON-PROMOTIONAL OFFICERS]**

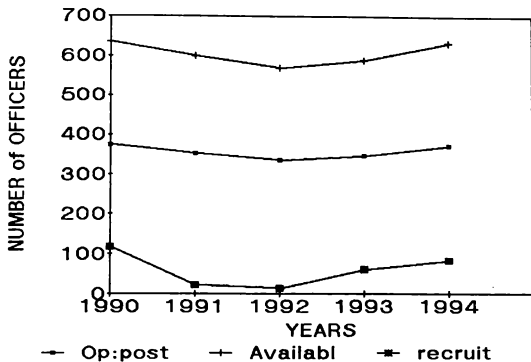

**WASTAGE & RECRUITMENT PROJECTIONS
[PETTY OFFICERS]**

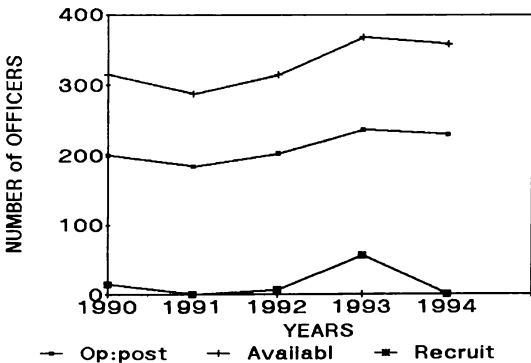

COMPUTERS IN SHIPPING

Computers are versatile machines capable of storing, manipulating, and sorting data at incredible speeds. The history of computers dates to the era of 400 BCs, the Pythagorean age. Invention of the ABACUS around 500 BCs and then logarithms by John Napier in the 16th century were just the beginning. The next stage was the slide rule, again by Napier. The 'Analytical Machine' was invented by Babbage in 1833, thereby putting a firm stone in the historical foundation of mechanical calculators.

During the next century the mechanical calculators became the forebearers of today's computers. All this computer revolution was taking place at a fast pace. But it took some time for the shipping world to overcome the inherent lethargy and welcome the computers into its fold. Now the trend is towards quick computerization of all shipping activities.

Five major factors made the entry of computers and its high growth in shipping possible.

1. Prices of computers are no more alarming, and many consider installing computers to be a sound investment decision.
2. Equipped with computers, the ship owners and ship operators are in a better position to feel the pulse of the ever competitive market field of shipping.
3. Data management and communication are fast, accurate

and effective through computers.

4. The computers and the programmes are becoming more and more user friendly. They are designed in modular fashion incorporating ergonomic controls both for shipboard and shore based office use.
5. The computers have become higher in capacity but are growing smaller in size. Installing a computer system no longer requires such a large space.

In this chapter, we will look into the various fields of shipping where computers are used. A knowledge of this will enable us to prepare the training needs in a much better way. The information in this chapter could also be used as part of the course material itself.

A large number of complimentary systems are in use at various connected fields of shipping like agent's offices, ship chandlers, machinery manufactures, suppliers, ports, national maritime administration offices, classification societies, maritime training establishments, and international organizations like IMO, WHO, UNCTAD, etc.. This, however will not be discussed in this thesis in an effort to limit the scope of the paper.

6.0 Use of computers in shipping

Thus, with its unparalleled advantages, computers are now everywhere in the modern shipping industry. Basically the areas of use can be divided into 5 major categories.

1. Ship design and ship building.
2. Shipboard operations.

3. Shipping company operations.
4. Communication and information channel systems.
5. Offshore operations.

More importance is given to items 2, 3 and 4 in this paper since it is aimed towards a shipping company and not towards a ship yard or a design firm. However, a brief description of the others is included for information.

6.1 Computers in Ship Design & Ship Building

Ship design is an extremely complicated proposition. From the planning stage to the readiness of a design, from keel laying to ship launching and from trials and tests to final owner acceptance, all the processes involve a tremendous amount of work by a large number of professionals. A typical flow chart of the design and construction of a ship is given in Annex. 6.1.

Within the design itself, there are a number of steps involved. This is depicted as the design spiral shown in Fig. 6.1. It involves a large amount of calculations, using mathematical expressions and the use of graphical solutions. Then at every stage, new information is added to go around the spiral a number of times till the entire data are incorporated. This is time consuming and tedious. Mr. D.J. Archer and G. Marshal of BMT, UK opined that the design spiral "models the way in which decisions are made, but not necessarily the way in which we design things. From experience and observation, practical design seems to be characterised by an ill-formulated array of activities superimposed on a general sense of direction". Computers have been a real boon to the designers and builders in this respect, with their capability to

formulate arrays in the sense of direction actually needed without the time loss.

Computer aided design modules help the designer to design the ship, model it, conduct finite element analysis, modify and test it, all before even making an actual model or a prototype. Such a computer design system is shown in the Annex. 6.2.

The next stage is production of final drawings and transferring these drawings through plotter techniques. Numerically controlled machines are then used to manufacture these patterns and body structures. Modern ship building would be a difficult task without the computers and the CAD and CAM techniques.

HODES is a CAD system for conceptual design of ships. This was developed by MARIN, Netherlands. This programme incorporates the design spiral by Buxton, (in Engineering Economics and Ship Design, BSRA report- Aug 1971).

MULDIF is another programme, based on the three dimensional sink theory. This programme was developed by Marintek, Norway and is designed to calculate the hydrodynamic properties of floating bodies.

Nautilus by New Wave Systems is a pc based programme of similar nature.

Most of these programmes have the capability to allow modular replacement to account for technological changes. Future developments in shipping CAD/CAM will include utilisation of very rapidly developing microcomputer

hardware, particularly in the area of transputers. Software developers are trying to refine the systems for handling the design of spaces within ship forms and in developing better engineering system design modules.

6.2 Computers onboard ships

The major ship board application of computers are divided into four areas.

1. Navigational controls.
2. Engine room applications.
3. Cargo control area.
4. Ship administration and record keeping.

They can be used as isolated systems or as an integrated system. In isolated systems they are used for single functions which are then transferred to output files. These files may then be used as input in another area. In integrated systems they work in isolation, but can be interlinked as required. They can also be hooked on to shore computers through satellites. (see Fig 6.2)

Bridge systems are used for safe navigation, while the engine room system optimizes the machinery operations and safety. 'Cargo masters' monitor the cargo operations and vessels' structural safety. The 'administrator' computer looks after the general administration on board ships. Most of these systems are designed "user friendly" for ease of operation. However, they do need a fair amount of knowledge of computers in order to operate them safely and efficiently.

1. Bridge systems.

The bridge system monitors the routes, weather conditions and predicts a safe, navigable path. They are provided with man/machine interfaces capable of fast operator actions and recall facilities from the memory. Graphics are projected on Visual Display Units (VDU) to give visual representation. Further graphic additions are done through a number of input devices. Some of the bridge computer functions are listed below.

1. Automatic position fixing.
2. Integration of ARPA with automatic chart tables.
3. Course planning and monitoring.
4. Auto piloting and weather routing.
5. Creation of electronic charts.
6. Passage economics.
7. Cargo planning calculations.
8. Ship's stresses calculation.
9. Data logging.

2. Engine room applications

Engineering operations from normal routine watch keeping to the complex combustion control of the main diesel engine are monitored and controlled by computerized systems, in new ships. A number of systems are available in the market which can be used directly in various functional areas. Some of the major areas in the engine room where computers are used are given below.

1. Alarm monitoring and control.
2. Temperature & pressure monitor and control.

3. Diesel engine operation and automatic control.
4. Machinery surveillance.
5. Engine performance analysis.
6. Safety network systems- fire alarms, bilge alarms etc.
7. Electrical power balancing.
8. Fuel management systems.
9. Inventory control & spare part management.
10. Plant preventive maintenance.
11. Data logging and transmission.
12. Communications.
13. Boiler and other power plant controls.
14. Emergency operations.

3. Cargo Monitoring and Control

Modern cargo operations are entirely executed by the computers. This ensures safe conditions throughout the cargo operation. The facilities depend upon the system selected, type of vessel, and type of cargo carried. A typical system would include some of the basic functions as given below.

- Cargo calculations
- Cargo loading and discharging rates
- Cargo distributions (segregations and separations)
- Stress calculations
- Stability controls
- Continuous monitoring
- Logging and documentation

The aim is to give the ship's master all the relevant data regarding loading and the stability conditions of his vessel, within the existing short loading times, to enable him assume his legal responsibilities properly and assist

him when it comes to his moral responsibilities towards his crew, passengers, maritime industry and the public in general. One such system used on Ro-Ro vessels is depicted in fig.6.3.

4. Integrated Ship Electronics

The first step for integrating navigational data, radar display and automatic chart table was taken in 1971 by Decca Radar and Navigator. This brought together all main information required for navigation through a computer called MANAV. It was fitted and proved satisfactory on ESSO MERSEY, but was not a requirement at that time. Later in 1982, the integration systems came up, bringing navigation, engine operations, cargo operation and onboard administration functions together. The system included position recording and monitoring, hazard avoidance and course planning with access to engine data.

This type of integration provided a number of advantages to the operator. All instrument display and control functions relating to an operational area were provided in a single console with one video display or a number of small displays so that the data available to the system is combined and accessed in a manner so as to assist decision making. It also allowed dispensation of many discrete instruments, thereby optimizing the man-machine interaction.

5. Total Ship Systems

The integrated system discussed above normally operates by bringing back and forth the data collected individually from bridge system, the engine room system and the cargo

system.

This interlinking of discrete systems had an effect of individualized controls, with a capability for interaction with the other phases. Take the case of the bridge system. It consists of partial control of the engine from the remote location, and control of navigation and management of various communication systems from the bridge. For example, bridge controls are mainly the steering unit and telegraph control which are assisted by the magnetic compass, radars, ARPA, gyro, echo-sounder, radio trans-receivers and satellite systems. All of them remain independent. All of this equipment is normally used for a single function, ie, navigation. But they are fitted haphazardly on the bridge.

The present thinking is to fully integrate this equipment and to have a total control room; something similar to that of a flight deck. Projects are underway to find possibilities to assimilate all operational functions and achieve an effective control strategy and improve safety. The watch keeper would be able to get a consolidated set of information on which he can take his decisions. His decisions also could be checked out by the computer before implementing. In brief the "Total Ship" system would be an active system rather than a mere information channel and could act on the command signals to activate one or more of the sub-divisions.

Use of Expert Systems and Fuzzy Logic systems would even enable the computer to take direct actions which can be approved by the operator. The machinery and equipment could then be activated by the computer inter-active controls in order to give optimum output.

6. Intelligent Ships

Many countries like Japan, Norway and Germany are presently engaged in "Intelligent Ship Projects". The concept is to design a highly reliable ship, capable of performing maneuvering and other operations automatically. High degree of instrumentation is used for feeding the data such as meteorological observations, sea and wind conditions, engine & hull conditions and ship routing. They are fed into an artificial "intelligent centre", where the analysis is done for decision support menus. Expert systems are linked up to the network as part of the project. A typical configuration of the systems being developed by Japan is expected to have the following functions.

A. Integrated operation control system.

- Integrated on board control.
- Data communications.
- Land support systems.

B. Automatic Navigation Systems.

- Collision avoidance.
- Grounding prevention.
- Navigation generalisation in harbour area.
- Self guidance in harbour area.
- Route setting in coastal region.
- Collision avoidance in coast & harbour.

C. Automatic Berthing

- Berthing and unberthing control.
- Ship's own position recognition.
- Communication to tugs/land/berth.
- Mooring controls.

- D. Engine Controls and Monitoring.
 - Combustion control.
 - System surveillance and diagnostic systems.
 - Mechatronics. /12/
- E. Optimal Route Planning.
 - Automatic route planning and weather routing
 - Economy passage
- F. Sea and Weather Monitoring
 - Wave observation
 - Weather forecasting
- G. Cargo Handling Systems
 - Automatic loading and unloading
 - Stress control
 - List/trim corrections
- H. Automatic Anchoring
- I. Hull Monitoring
 - Hull condition monitoring
 - Propulsion analysis
 - Attitude control
 - Trend analysis

6.3 Shipping Management Information Systems (MIS)

The most important use of the computer in shipping is for information processing. Information is the back bone of any shipping activity. The decision making process, specially in a highly volatile market conditions, is very difficult if sufficient information is not available or if the information available is not correct or it is too voluminous. Unless the information is properly collected and stored in an orderly manner, the manager or the ship operator will find difficulty in taking correct decisions.

Not only should the information from external sources be studied, but also information from within the organisation and all its functional areas should be studied as an integrated data. A broad spectrum of the shipping management functions are shown in the Annex 6.3. All these functions are brought together before conclusions are drawn and actions are taken. It is a massive task by itself. If we look at each of these basic functions, there are a number of internal elements within. These internal elements may have to be handled individually. For example the technical ship operations would include the following;

- crewing.
- maintenance and repair
- surveys and classification
- insurance
- provisions and stores
- spares and inventory
- performance of ship movements
- bunker supply and economics
- breakdowns, accidents and investigations
- layups and drydocking
- cargo operations analysis.

A complete list of these sub-operations is shown in Annex 6.4. This list is not an exclusive one. But a look at these various operations would give us an idea of how complex the system could be. Computers are used to a large extent to integrate the information from various sources and to store in the data bases. These data bases can be retrieved at any time for further appending or for providing information to the management.

After seeing the various operations of the shipping company let us now look into the different fields where the computers are used or can be used effectively.

A. Corporate Planning: Decisions on policy matters are made at the corporate level which therefore require that relevant data is available at very short notice. This can be achieved through computers, in the following fields.

1. Project planning.
2. Vessel and tonnage optimization.
3. Investment analysis and planning.
4. Financial planning and budgeting.
5. Fleet planning.
6. Research and development systems.

B. Vessel Operations: The day to day operations of ships as well as the long term plans are efficiently handled by computers placed within the operations department. It gives them a chance to optimise operating parameters with judicial analysis of previous data with respect to the existing conditions and constraints. Computers can be used in the following areas of ship operation management effectively.

1. Plant preventive maintenance.
2. Data from conditioning monitoring.
3. Spare parts and Stores inventory.
4. Performance monitoring and analysis.
5. Stress analysis and cargo planning.
6. Damage stability and analysis.
7. Weather routing advices to the ship.
8. Ship manning and crew training.
9. Bunker management and energy balancing.

10. Dry dock and repair specifications.
11. Standardising routines and formats.
12. Trend analysis.
13. Survey history and records.
14. Crew payment, and other accounts.
15. Casualty reports and investigations.

C. Commercial operations: This is a field where a large chunk of probability analysis and chance taking lies. Most of the time the decisions are based on the "gut feeling" of the commercial managers. Now these gut feelings can be supported and checked by the use of excellent data bases created by computers. Some of the areas of commercial operations where computers are used effectively are;

1. Sale and purchase of ships.
2. Ship broking.
3. Ship chartering.
4. Insurance claims monitoring.
5. Market survey.
6. Cargo booking and ship positioning.
7. Passenger booking and scheduling.
8. Container operations, tracking, etc., and
9. Customer contacts and data bases.

D. Intermodal Operations: This is another area in a shipping company where computers are already tried and have proved to be successful. A number of variable parameters like ships capabilities against cargo carrying requirements can be analysed. The outputs are used for further modifications in the vessels parameters by retrofits or for modifying the charter party. Some of these operations are;

1. Vessel routes and schedules,
2. Mileage monitoring,
3. tachograph analysis, and
4. route tariff and market monitoring.

E. Data communications: Communication is an essential link in any business, and in shipping it is one of the most essential linkage. It is the communication system that allows the ship operator to keep track of the market, of his ships, its performance and of various other sub-systems. Use of computers here is mainly centered around:

1. Document transmission,
2. Ship/shore communication,
3. Shore based communication, and
4. The satellite communication.

A number of data systems are also connected up with public trade information, political international moves and market reports. This information is used by computers to report on commodity flow analysis, market analysis, vessel deployment analysis, market trend potentials etc.

F. General Administration. The overall management and administration can also be assisted by computers. The information and work that are commonly handled by computers are given below.

1. Records of personnel.
2. Salary payments.
3. Electronic mail.
4. Word processing.
5. Document publishing and stationary.
6. Other secretarial functions.

6.3.1 Discussion of a particular use.

To appreciate the use of the computer as a management information tool, let us now look briefly into how it is used in a chartering department to fix a charter and analyse the results. Annex 6.5 is a typical Management Information System specific to a charter department.

A computer is used for cost model analysis and finding out the optimum charter rate. The central computer has a number of inputs like the ship's capabilities, its voyage particulars, a database input with market conditions and a basic cost model. These inputs are analysed against the charter party offers. Once the analysis is done and compared with cost models, the fixture is made by the commercial department. This can further be put into a regression model to plan the voyage. Once the voyage starts, at every stage of the actual voyage, results are compared with the regression model to get the variance. This allows the commercial operator to correct any possible error before major damage is done. At the end, result of the voyage is analysed and the output is stored as "experience inputs" into the data base. This cycle goes on and on, with the data being stored at every stage.

6.4. Communication and information channels.

When we discussed the use of computers in a shipping company, we saw the flow of internal information. But the main information need is from external sources. The possibility of combination of computer science, television technology and communication engineering through telephone

systems or radio signals has resulted in a different use of computers; that is for connecting external data bases to internal data bases.

The external data bases are linked to the shipping companies and to the ships either in a single channel or a dual channel communication flow network system. A number of such networks are already operating and are available to the shipping industry. The single channel system allows you to receive data continuously or at pre-determined intervals. These data are of general information nature like weather forecasts, port delays, currency exchange rates etc.. The two way channels are established where one can route the data to and fro. The Telematics network system is one such model (Fig. 6.4).

Dealing with such systems could be expensive, if proper care is not taken. It is quite tempting to transmit masses of unnecessary data which may conceal the prime information some where in a corner. It would significantly increase the volume of data and its cost in sending. Added to this would be the difficulty of identifying what is important and what is not, from the large volume. Hence some important matters must be told to the operators and users regarding the proper use of such systems, which can most effectively be done through proper training. Some of the points to be kept in mind are given below.

- quality of data
- freedom from error.
- transmission time costs.
- accessibility to marine zones.
- routing possibilities ashore.
- overall cost with respect to quality and

quality of data.

6.4.1 Systems in Operation.

The modern maritime communication is done through satellite systems. With the establishment of IMSARSAT, the International Maritime Satellite Organisation in 1976, the ship/shore communication has become fast and cost effective. These systems have the advantage of instantaneous high quality service at any time with very low disturbance from the charged atmosphere. An Added advantage is the improved safety and distress service facilities. The operation of these systems are controlled and co-ordinated by a number of computers installed at the Coast Earth Stations (CES) and the Ship Earth Stations (SES). A typical system is shown in Fig. 6.5.

A number of remote information services are available commercially. Videotex in UK is an interactive information service available to the shipping industry. "Teletext" is also similar to Vidiotex but is a non-interactive service which is usually available on TV broadcasts as part of a normal transmission signal as "Pages" of information. CEEFAX from BBC and ORACLE from Independent TV channels are also good examples of teletext facilities.

Viewdata is a general term for an interactive information service and is available to shipping circles. They provide information like:

- a. Market information- vessels details, new building programmes, shipping movements, fixture reporting, open tonnage and cargo flows.

- b. Business information- stocks, financial reports and company performances.
- c. Industry information- abstracts and references from newspapers, magazines and conference reports.
- d. Communications- alternative forms of communication.
- e. Ship-based systems- on line information for ships officers and passengers.

Marconi Software systems have developed a "shipwide information distribution and collection system" called SIDACS. It provides fast and accurate acquisition, distribution and display of data that is crucial to the efficient functioning of the ship. The system combines real time data acquisition with a dynamic text and graphic display on intellegent monitors. The information system is constructed in a modular fashion to suit the general requirement for ship management information, or a specific need such as engine monitoring or navigation information. Menu driven instructions assist editing both text and graphic pages and simple keypad operations take the user to the required information display. The maker claims that it is a simple and safe system for shipboard operations.

6.5 Computer Application to Offshore.

The main areas of computer application in the offshore field are as follows.

1. Computer assisted offshore design.
2. Computer graphic engineering design.
3. Analysis of offshore structures.
4. Motion and stability study.
5. Simulation systems.

5. Simulation systems.

6. Data processing and communications.

The offshore operations are very much similar to the operations of a shipping company. Hence the computer applications are also similar. In areas like the dynamic positioning of vessels and other special purpose vessels, computers are used to assist in manoeuvring the ships.

CAD and graphic engineering are mainly used in the offshore structure design. These structures are then analysed and tested through computer assisted testing programs prior to installation. There are programs to study the behavior of motion and stability under different wave and sea conditions.

CADKEY-3 is a system using the three dimensional model geometry for the design of offshore structures. Data created in CADKEY can be transferred to yet another programme called IMAGES through an image translator in the form of sequential files. Then the effect of wave direction, wave height, wave period, current profile and force coefficient are studied and analysed.

The simulation domain considers 2 types of programmes. One simulates the motions of floating structures and offshore operations, while the other simulates the manoeuvring behavior of advanced high speed vessels.

6.6 Computers in SCI.

Keeping pace with the technological developments, SCI started its computer phase in 1972 by acquiring an IBM 1401. At that time SCI was the only shipping company in

India to have a computer. Over the years more and more areas were identified and computerized which resulted in an increase in the work load on IBM 1401. This was solved by hiring commercial computer time from various firms.

Since communication and computerisation was identified as one of the thrust areas, a separate department, by the name "Computers and Communication Department", was formed in 1987.

Further a new computer controlled electronic telephone exchange was installed at the head office, with facilities of voice and data transfer. An automatic message switching station was set up for the telex and teleprinter centre at Bombay.

During Sept 1989, a fourth generation IBM main frame 4381-P-12 was installed and was made operational in Dec '89. It has a main memory of 16 MB and a peripheral memory of 10 Gigabytes - providing storage capacity equivalent to 3 million typed pages. Starting with an initial support to 60 terminals, it has capacity for expansion when needed.

SCI also plans to acquire a number of minis and PCs which can be networked with the main frame. These PCs will be installed at various operating points with direct access by the operations managers.

In SCI, computer applications have been planned for execution in a phased manner. The areas computerized as on Jan'90 is shown in Annex.6.6. Phase one and two would follow in the near future. Other plans include computerization of the Calcutta, Madras and other offices.

The entry of main frame computer would bring extensive changes in information flow and working of SCI. A fully integrated MIS is also operational, assisting in performance analysis and as an information data bank.

During 1984-89, twenty eight of SCI ships have been fitted with SATCOM and more ships are being fitted out every year. SCI is also considering using computers on board extensively. Some of these areas are Engine diagnosis, Electronic charts, and administration. SCI is also considering fitting micro computers on board ships, which can then be linked upto the main frame via the satellite link for ship/shore data transfer.

It is expected that during the next few years, SCI would have massive computerization both in its fleet as well as in its shore operations. This would need gearing up for the manpower development in these high technology areas.

-----o-----

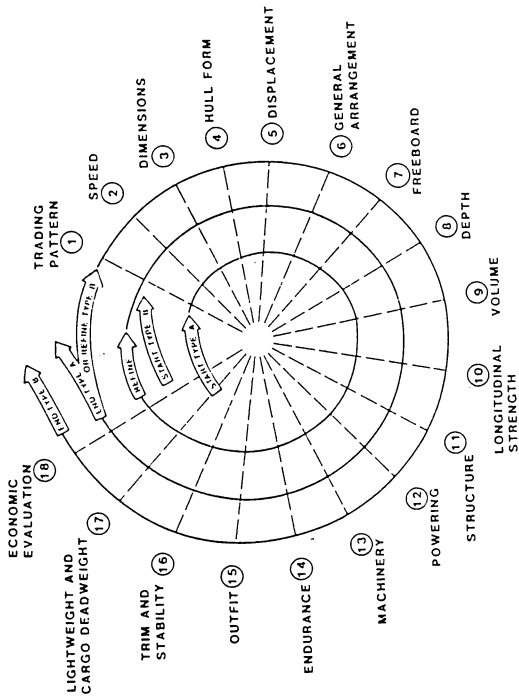
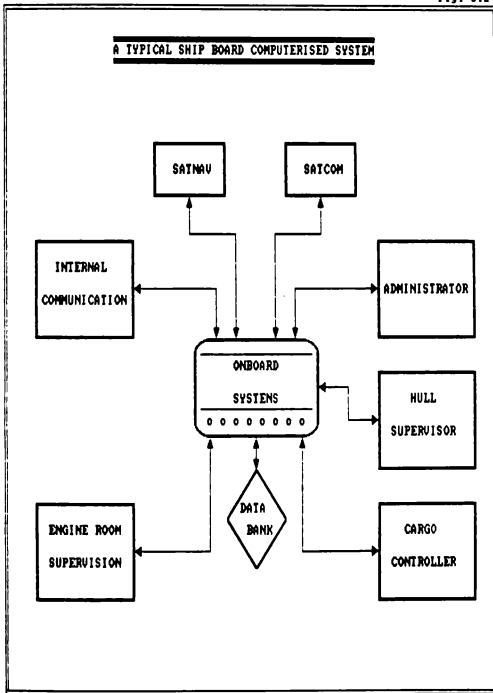

Fig. 18 pp. 11

Design spiral according to Buxton

Fig. 6.2



FUNCTIONAL MODEL OF TELEMATIC NETWORK

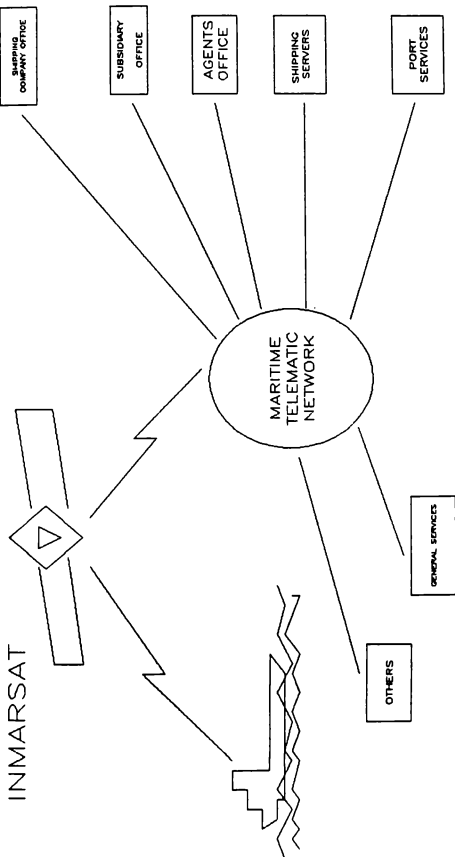
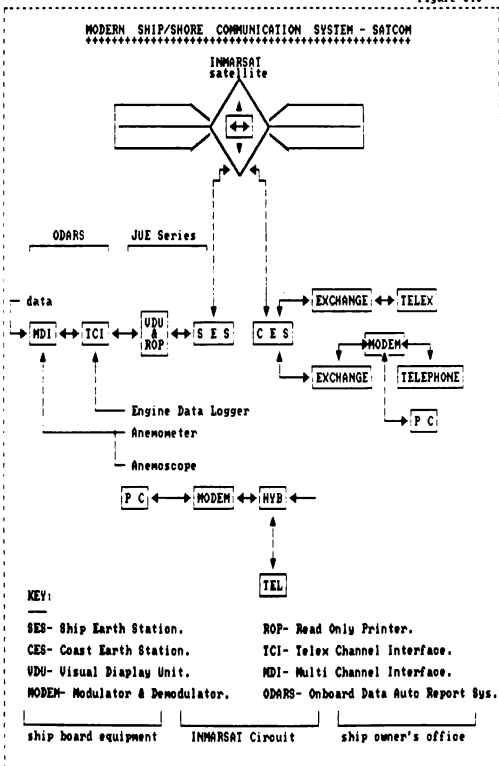
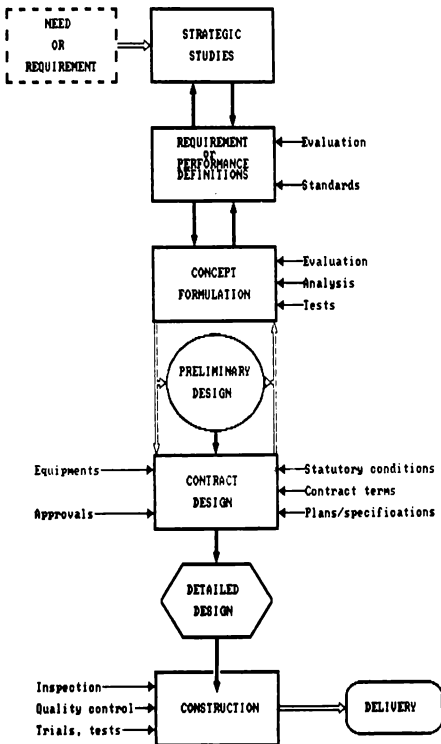

Fig. 6.4

Figure 6.5



Flow chart of Ship Design and Ship Building Process



COMPUTER ASSISTED SHIP DESIGN PROCESS

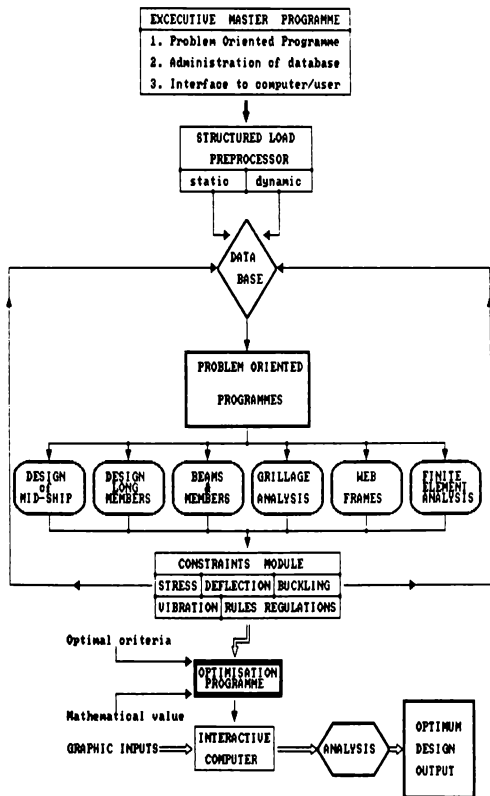

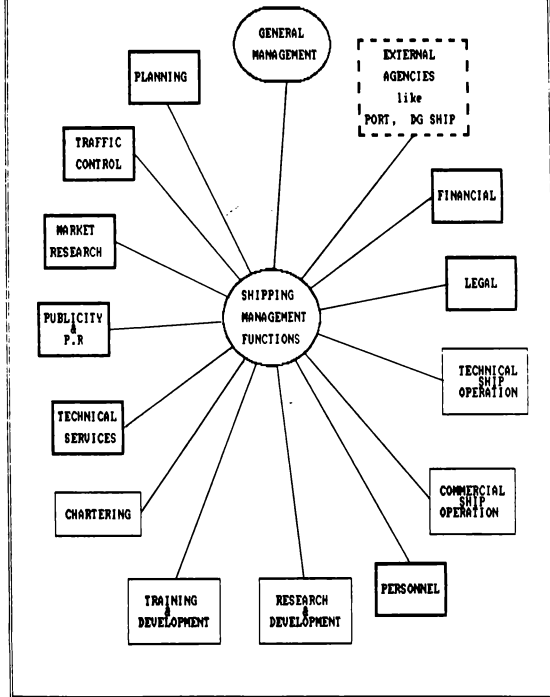
A TYPICAL SHIPPING MANAGEMENT FUNCTIONAL DIAGRAM

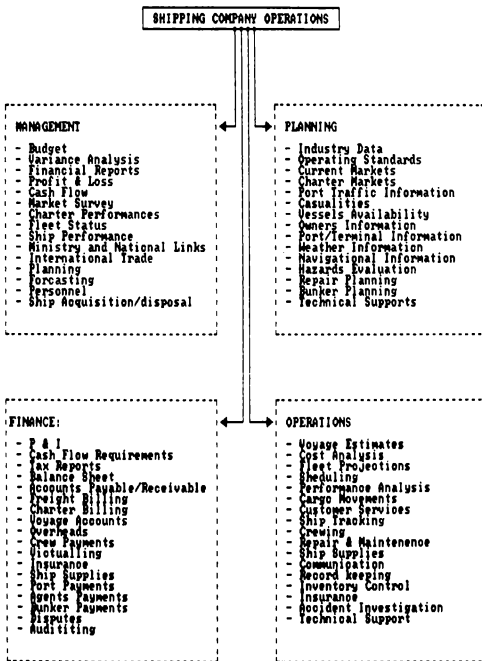

A TYPICAL MIS FOR THE COMMERCIAL DEPARTMENT OF A SHIPPING CO.

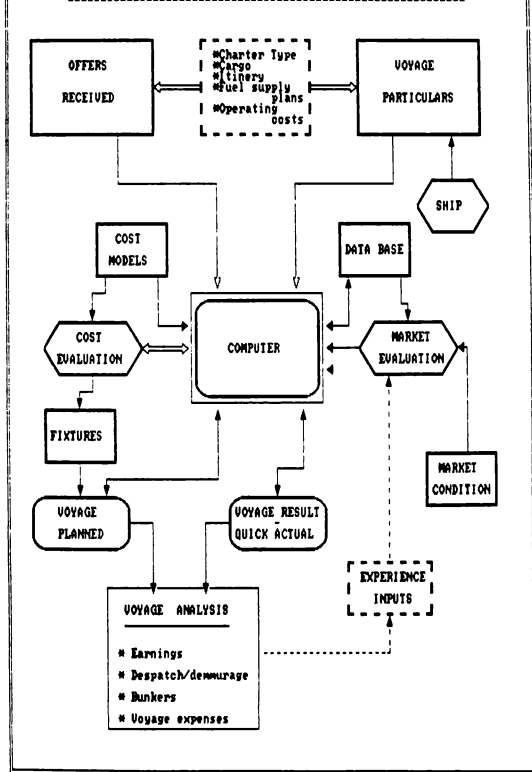

Division Wise Application of Computers

B & T division	LINERS division	CPS division	TECH-SERU division	FAO division	FINANCE division	PURCHASE dept.
PHASE 2 contd. -						
cost break breakdown analysis cost control inventory control management	management information system decision support system inventory control management	cost control inventory control management	material management inventory control	inventory control management		
PHASE 3 - TO BE IMPLEMENTED AFTER PHASE 2						
classification analysis inventory control management	cost management information system decision support system	cost management information system decision support system evaluation	accounting application software development management information system	cost management information system decision support system	accounts payable receivable	godown stock system inventory analysis management analysis inventory control management cost control management analysis

COMPUTERS in EDUCATION

The shipping industry is entering an era of apparently improved conditions. Greater amount of sophistication has found its way towards this industry. As can be seen from the previous chapter, computers have become an essential part of the modern shipping industry.

Against this background, maritime training is facing new challenges in providing highly trained manpower. In computers we have an excellent tool for training purposes; either in direct training or in in-direct training methods. Computers can also be used for the production of teaching aids and for the production of learning aids.

In this chapter we will see how computers are used in education and in an educational institution. Discussions are mainly centered around the question of "how computers can be used in modern training". Intentionally, the area of hardware selection, physical facilities and other subsidiary requirements are kept out of the discussions, due to the limited scope of this paper.

7.1 Historical Background

Though there were instances where computers were tried out in education, it was around 1940 a structured education pattern with the help of computers really emerged. This was followed by the Programmed Instructional systems called PI systems. Then, in and around the 1950's, universities started using computers for their administrative purposes.

COMPUTERS in EDUCATION

The shipping industry is entering an era of apparently improved conditions. Greater amount of sophistication has found its way towards this industry. As can be seen from the previous chapter, computers have become an essential part of the modern shipping industry.

Against this background, maritime training is facing new challenges in providing highly trained manpower. In computers we have an excellent tool for training purposes; either in direct training or in in-direct training methods. Computers can also be used for the production of teaching aids and for the production of learning aids.

In this chapter we will see how computers are used in education and in an educational institution. Discussions are mainly centered around the question of "how computers can be used in modern training". Intentionally, the area of hardware selection, physical facilities and other subsidiary requirements are kept out of the discussions, due to the limited scope of this paper.

7.1 Historical Background

Though there were instances where computers were tried out in education, it was around 1940 a structured education pattern with the help of computers really emerged. This was followed by the Programmed Instructional systems called PI systems. Then, in and around the 1950's, universities started using computers for their administrative purposes.

Interestingly, one of the first computers, the Whirlwind, was designed primarily for instructional purposes. It was programmed to simulate combat conditions for training fighter pilots. PLATO was a system developed in 1960 by the University of Illinois for instructional purpose. By 1972, the Time Shared Interactive Computer Controlled Instructional TV systems (TICCIT) became popular in USA.

Early efforts of using computer in education did not receive much recognition because of the prohibitively higher costs involved and because of the ignorance of the potentiality of computers. But they made significant contributions to subsequent development in educational research. As the cost started reducing and as the capabilities of computers became evident, their usage started increasing. Between 1980 and '84, USA had a ten fold increase in number of computers used in schools. Other factors which influenced this increase are the wide spread application of computers itself and the availability of user-friendly programs.

Some of the milestones in the history of educational computers is shown in Annex 7.1.

In the discussions on educational computation, one is likely to come across various acronyms. Hence before proceeding further, let us have a look at these acronyms. They are shown in the Annex 7.2. The glossary of terms also may be referred.

7.2 Computers in Human Information Processing

The human information processing is an extremely complex

system. A number of environmental variables control the effectiveness of the process. The method used for the process plays an important role in the amount of information that is passed over from one human to another. This can be more complex when it comes to structured type of information processing as in teaching and learning processes. A model of the human information process is attached as Annex. 7.3. The teacher must know the area which he is aiming at. Is it a short term memory band or is it for long term remembrance? The resources must be selected properly and modified towards the specific need. Great care is required in order to generate the correct responses which would trigger the sensory organs to react the exact way and start perceiving the information input. It is thus the job of the trainer to see that he has the correct stimuli with him.

Different methods and media of instruction offers different stimulus. Each of them would create different responses on the learner. The types of stimuli are divided into five major divisions /17/.

1. Human interaction (verbal and non-verbal)
2. Realia (real things and events)
3. Pictorial representation (still and moving)
4. Written symbols (words, figures)
5. Recorded sound (speech, music, 'natural' noises)

Computerized training methods can bring four of these five systems together. The only one excluded is the human interaction systems. There are efforts going on to embody the human interaction into the computer systems through techniques of Artificial Intelligence.

Experience and experiments have shown that computers can be used as a valuable resource by the teacher as well as by the student. It can be programmed to create the necessary stimuli to accelerate the learning process and connect them up effectively.

The main functions of a learning process are defined as below./16/

1. Motivating the student towards learning.
2. Recalling his earlier knowledge.
3. Providing necessary stimuli.
4. Activating his responses.
5. Giving proper feedback, and
6. Encouraging appropriate practice.

As these new ideas and technology started invading classrooms, educationists began to see many advantages of using computers. These machines were teaching not only through words and conventional diagrams, but also through coloured animations and sound. This provides a challenging scenario to the students, making them more than willing and enhancing the learning process.

The use of computers in training establishments can be classified into 5 different sets as given below.

1. Computer Aided Instruction (CAI).
2. Computer Assisted Learning (CAL).
3. Computer Literacy.
4. Computers for Administrative Use.
5. Computers in Research and Development Systems.

7.2.1 Computer Aided Instruction (CAI)

The CAI system uses the computer as one of the job aids in teaching. There are a number of CAI programs commercially available. In the beginning they were simple programs with limited interactive capabilities. Today, intelligent programs are available with capabilities of teaching, testing, record keeping functions and which can be integrated with speech and touch controls. Based on Stimulus-response models, it provides the stimulus to the student and then depending on his response, it decides the next step. Annex 7.4 depicts the typical structure of a CAI programme.

CAI programs have several advantages over the traditional methods. Listed below are some of these.

1. They provide instant feedback to the students.
2. They provide a record of students progress and update them regularly and automatically.
3. They have infinite patience to repeat the same text any number of times.
4. They present the subject exactly the same way with out omitting any part or adding any unwanted material.
5. They are readily available at any time.
6. A number of software programmes are available on various subjects.
7. Updating of data is possible.

Research and studies have shown significant improvement on student's achievements through the CAI methods. However there is a group of people which opines that this makes the students forget team work and social needs. Hence CAI may

not be a useful method for teaching management subjects except for individualized simulation or game systems. But now a days systems are being built up with networking, which can interact with any number of participants.

7.2.2 Computer Assisted Learning (CAL)

Another name for this CAL is computer managed learning (CMI). It is designed to support the teaching process and invariably incorporates various aspects of CAI, except that the range of CMI is much larger.

Instead of teaching students directly or through CAI, here the computer directs them to the desired path. It tells the student to read a particular book, see a video, attend a session and then come back to the computer to check the score. Students can proceed at their own pace to complete the sessions. The timing will be marked against their score along with the contents evaluation.

Some systems consist of a fixed sequence teaching module. The next module is approachable only if the first module is successfully completed. A typical system is shown in Annex 7.5. The student can select the first module, and the computer presents the text and diagrams for study. Then it goes to a question and answer section to find out how much the learner has learnt. If satisfactory, then it presents the next module and so on.

These systems use large databases to perform various functions of managing the instruction and monitoring the learning progress. The diagnostic module can even prescribe extra lessons in order to overcome the inadequacies of the learner. It measures the effectiveness

of lessons and thus of the teacher indirectly, thereby giving good feedback to the teachers. This allows teachers and the administrators to modify the system if called for.

7.2.3 Computer Literacy.

Before we start using the computer either for teaching or learning, or for any other use, we must know what it is and how it is used. This is referred to as computer literacy. It is essential in view of the user, the programmer and the man who is going to maintain the hardware. Basically it is to learn the capabilities of the computer and how to communicate with it efficiently. In short, computer literacy deals with the following.

1. What is a computer?
2. How does it work?
3. What are its capabilities?
4. What is hardware, software, memory etc?
5. How to communicate with it?
6. How to programme it to do a specific job?
7. How to maintain it?
8. How to safeguard the data and the programmes?

7.2.4 Computers in administration.

In this field computers are used for various purposes as in a shipping office which was discussed in the earlier section. Some of the specific areas are given below.

1. Records of staff and students.
2. Progress reports of students.
3. Budgeting and Expenses.
4. Payroll of staff.
5. Record of courses.

6. Electronic mail.
7. Library management.
8. Inventory control.
9. Planning and execution of schedules.
10. Word processing.
11. Desk top publishing for course material.

Net-working facilities have opened up more possibilities of using the micro computers by connecting them to remote information centers. Telephone lines are normally used as transmission lines for data transfer from one station to the other. A typical example is depicted in Annex 7.6. This is a system in use at the United States Merchant Marine Academy (USMMA), where their computers are connected to the computers at Dartmouth University on a time sharing basis. This allows information flow between the two institutions thereby reducing the duplication of books and other information resources.

7.2.5 Research and Development uses.

Micro computers are extensively used in the field of research and development. They mainly have the capability of processing large volume of data which is essential for research and professional developmental areas.

In the development field, computers are used for modelling and testing of new systems and theories. This allows the research team to try out new systems before implementing. Simulation techniques are used in this field to a large extent. Modification of the systems is a matter of pressing a few keys on the keyboard and is highly cost effective.

A number of programs are available for both the designer and developer. Some of them are with capabilities of flow charting, logic circuit building, solid modelling, model testing, mathematical computation and simulation.

Guidance and special services are arranged through computer systems. For example, the MIT's (Massachusetts Institute of Technology) Athena project supported by IBM, allows the student to plug in his computer to the vast data source they have and then he starts selecting and studying a particular subject or area of specific interest to him.

7.3 Teaching with computers.

We have seen that computer education can be "teaching about computers" or "teaching with computers".

When it comes to teaching with computers all the factors can be identified as seven major styles.

1. Tutorial Instructions.
2. Drill Sessions.
3. Simulations.
4. Games and tests.
5. Problem Solving Techniques.
6. Intelligent-computer-assisted Instructions (ICAI).
7. Interactive Video.

Tutorial instructions can be fed as a special programme and students can interact by way of questions, answers, and information. They could also review and suggest better systems, which then acts as a feed back system.

Drill is a method to develop a standard proficiency in

carrying out specific works. By continuous question and answer sessions the student learns to work fast till he could complete the task in the predetermined time. This improves effectiveness and efficiency.

Simulation systems create a situation close to reality and allow the student to react. Diagnosis is then given to improve the reaction mode and timing.

Games and testing could be employed after class hours, to identify level of understanding of the students and then to plan for further training.

Problem solving improves analytical and motor skills of the student. It could be scientific, mathematical or even a natural problem. This works as a good motivator in improving his intellectual skills.

ICAI works in two ways- one with controlled progress while judging the student capabilities and the other by way of Expert Systems and Knowledge Engineering. They are developed only in the areas where the amount of knowledge available is small, but essential. And, marine environment appears ripe for this and needs assistance from Experts.

Interactive Video controls the video or the film projector or other such audio-visual equipment by computer in order to enhance or supplement the learning situation.

With the help of these programmes, pre-evaluation and selection of candidates for a specific course is very easily done. A Q-A module is placed at the beginning of the session, before the actual text is presented, as shown in Annex 7.7. This acts as an evaluator.

Basically all these computer based training systems could be tailored to three basic characteristic approaches.

1. A prescriptive approach- where the students are told what to do, how to do and when to do.
2. A student approach- where it allows him to experiment and find out what to do and why it is done.
3. A cybernetic approach- which guides him through each step in an orderly manner, giving information, giving feedback, and trying to optimize his learning experience.



7.4 Advantages of computerized education

"It is often said that all learning is individualized. After all -the learner learns- and nobody can do it for him". (Romiszowski-1984)

The teacher can only help to develop the right environments, and give certain information. Learning may depend primarily upon the teacher student relationship where individualized complete attention is focussed on the transfer of knowledge. The efficiency would depend on the skill of the tutor, motivation of learner, time and mode of teaching, and various other factors.

Computerized systems have many advantages over these conventional systems, since it is a highly motivational system. The flashing screen attracts the trainee and creates a receptive attitude and gives information as to what training it is. A well formulated CAI program gives out messages to keep the trainee in touch with the subject matter all the time. But remember, long, complicated and

sarcastic messages may annoy him.

Checking at the entry level to find out the student capabilities, can save time and monotony which may be present for a student who knows more. This further allows him to go to the required level of study rather than going through what he already knows.

CAI systems are effectively used as supplement to classroom sessions where the student can be put through repetitive drills and practices till he attains proficiency. Skill development is one of the primary aims in this.

A re-orientation of skills could be very easily conducted through the programmes called -'brush-up'. In application engineering this is very beneficial. For example, a chief engineer joining a new ship could go through such a brush-up self study programme where the new ship system is presented to him. With his already existing knowledge of engines and machinery systems he can master the new system easily. This will give him familiarity of the ship before joining. The same could be done with navigators.

The computer interacts with the student's styles, manners, difficulties and brings him up steadily to the goal point. In addition there is a continuous record of what is learnt, how much is learnt, and how much time is taken. This can be used for perfecting the performances.

These systems move at the students pace, and no time is lost for others. If needed the student can go through the sessions in his free time.

Advantages of audio, visual, and touch senses are utilized

to the maximum and pave the path to knowledge- "Guide de la vie".

It pays individual attention, without disturbing others.
It also keeps a record of progress which can be checked at any instance. The feedback helps the trainee to know where he stands at any time.

The student is actively involved. It makes learning more interesting and easy.

The performance shaping factor is high in computer training systems since it makes the student the "master performer" rather than just remaining as one in the audience.

Above narrated are some of the advantages of CBI systems. Individual systems do offer much more than what is mentioned above, like in simulation systems and in knowledge based systems. These systems are briefly discussed in the next chapter.

7.5 Tips of Computer Course Design.

At the conclusion of this chapter, let me give some useful hints for designing a proper course in computer.

Educational technology is the soft science of transferring information from one to another so that the receiver retains the information for a longer period. The basic tenets of education are to achieve:

1. Output in measurable terms.
2. Task analysis to specify the areas to be taught to achieve the output.
3. Systematic development of the material.

4. Initial testing.
5. Revision and pilot conduction.
6. Evaluation.

The objectives are to be instructionally sound, visually stimulating, comfortable to the users, and with maximum interaction possibilities. They must be capable of tying up with other programmes and with other media like slides, films, etc.

Proper directions must be included on how to start and how to proceed by way of on the screen instructions and help screens. This would give proper guidance to the learner and he will not feel lost in the computer jargon.

The design must stimulate the previous knowledge and encourage the student to study further. A pretest and results would evaluate the student at the entry level giving him messages like " Not ready for lesson 2", "Ready-Go Ahead", "Very Good- You may skip next lessons and go straight to the fourth" and so on. This has a high motivational value.

The design must be flexible in order to allow for freedom of thinking and creativity. It is therefore advisable to give open loop systems. The trainee must always be kept under control with proper guide lines and information.

The information presentation calls for great care. Use of texts mixed with graphics, sound effects and photographs would get immediate attention of the trainee. Too long sessions would be very critical and would depend on the student response. Time of presentation, mode of presentation, and information content all are part of

response creating elements. The lay out must be smooth for reading without putting too many lines in one screen. Scrolling of the screen will adversely affect the trainee. Capitals and highlighting will help him.

The text must have consistency and relevance. It must be presented in an orderly manner and with interactive graphics to maintain the interest of the student. You can even create a spirit of competition with other students or with the computer. It all depends on the creativity of the designer.

7.5.1 Skill Requirements.

Production of the CAI courseware requires a number of different skills including;

- knowledge of subject matter,
- knowledge of course design,
- knowledge of training & education technology,
- computer programming through a general knowledge or a special authoring language,
- graphic design capabilities,
- creativeness and vision,
- co-ordination.

You may not be able to find all these qualities in one person. However you can have a team of experts in a group and produce good coursewares.

The use of authoring systems helps the teacher to do the job of CAI courseware design even if his knowledge of computer programming is poor. A number of authoring tools are available commercially. Some of them are PILOT, TUTOR, ENBASIC, AUTHOR, CAI PLUS, PASS, PHOENIX, WISE and PHASE II.

- 1888 Pueblo Plan, laboratory scheme to pace students with his own coverage of course.
- 1922 Parkhursts Dalton Lab. Plan of self instruction.
- 1940 Begining of Programmed Instructions- PI systems.
- 1950 Computers used as administrative tool in universities.
- 1960 PLATO project of University of Illinois for CBI(Computer Based Instruction).
*PLATO stands for Programmed Logic for Automated Teaching Operations.
- 1960 "Course Writer" by IBM, a programming language for instructional material.
Free choice system at UK.
- 1960 Introduction of Complex adaptive teaching machines.
- 1963 Washburnes Winnetka plan of self instruction.
- 1963 Keller plan named after Frei Keller. A conversational programme, with highly simulated patterns.
- 1967 Leicestershire plan. an approach to integrated study.
- 1970s Computers for military instructional purposes.
- 1970 PLATO IV, a large time shared instructional system through telephone lines controlled by computers, capable of linking to 600 students.
- 1972 Development of Time Shared Interactive Computer Controlled Instructional TV. (TICCIT) by MITRE corporation and Brigham Young University.
- 1972 Formation of Minnesota Educational Computer Consortium- MECC.
- 1974 Artificial Intellegence and Expert Systems.
- 1974 LCI- Learner Controlled Instructions.
- 1975 US Navy computer managed instructional system.

Annex 7.2

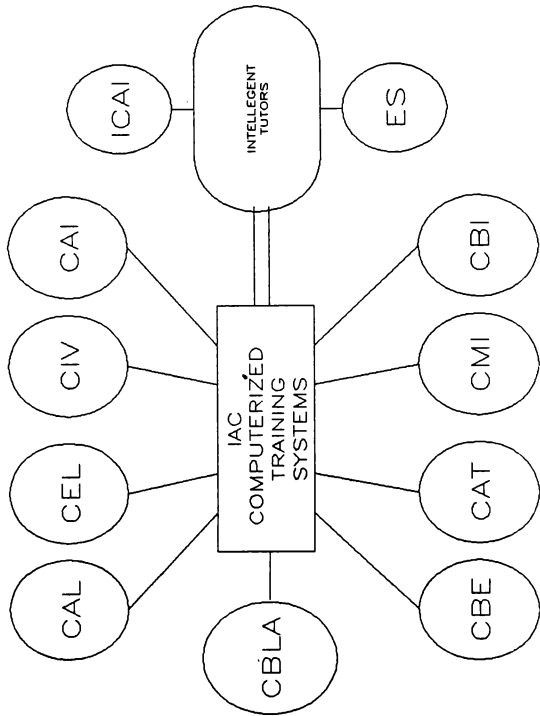

See Chapter 7
for fullforms
of these

MODEL OF HUMAN INFORMATION PROCESSING

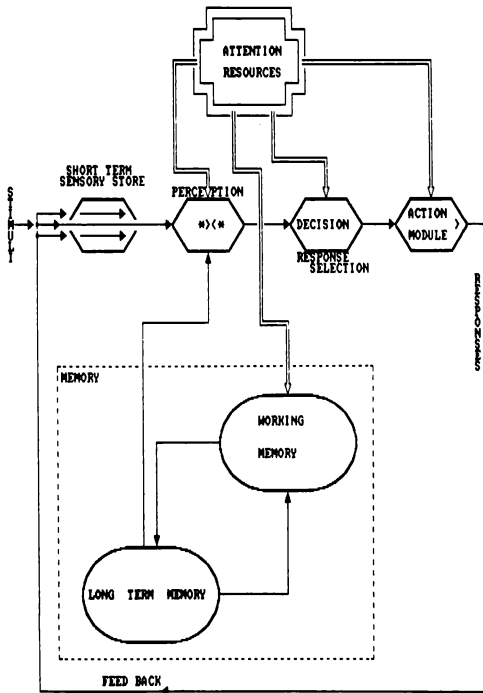

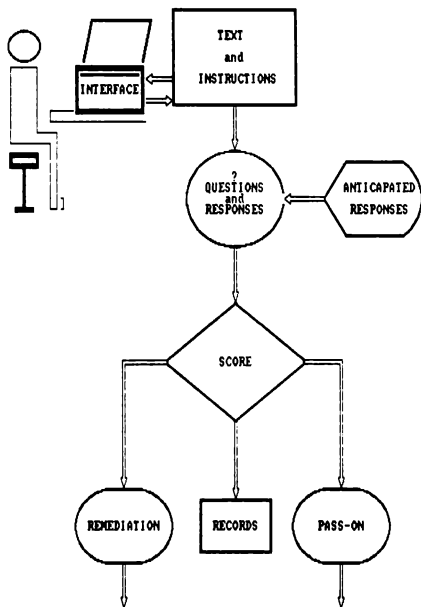

A TYPICAL C.M.I. STRUCTURE

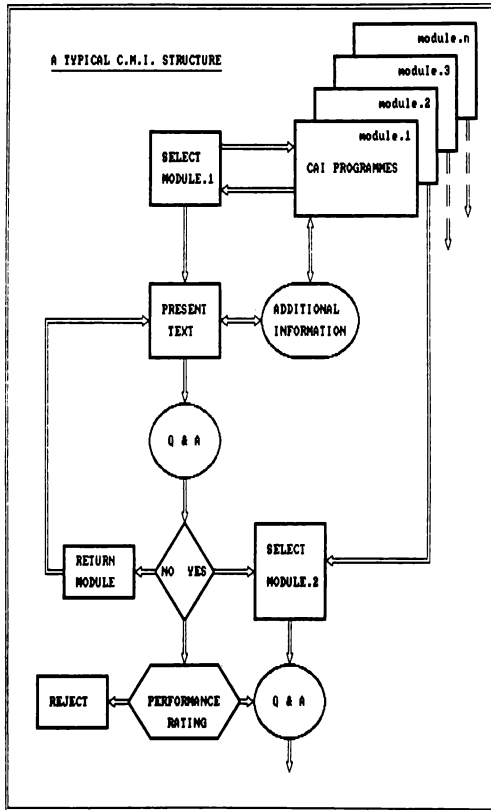

Dartmouth - U.S.M.M.A. Computer Network

Annex 7.6

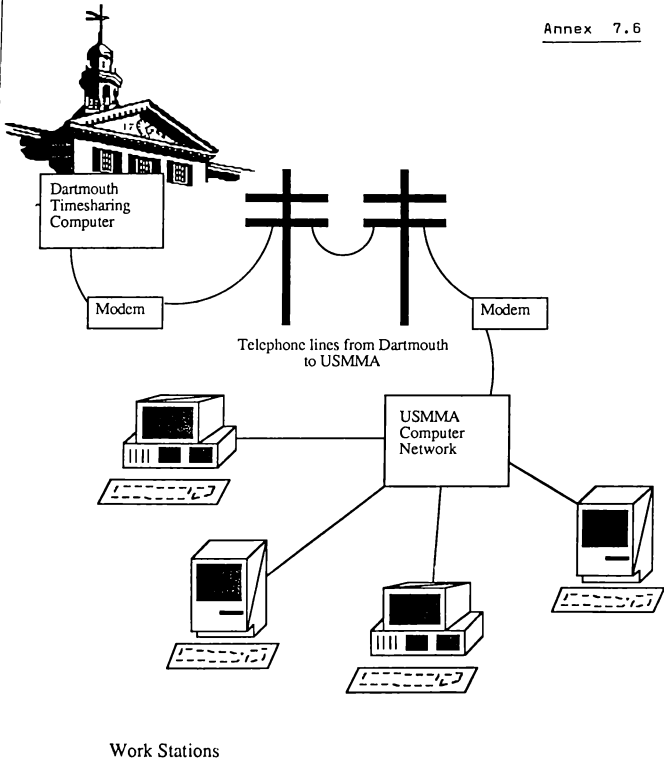

A PRE-EVALUATION AND Q-A MODEL OF CAI

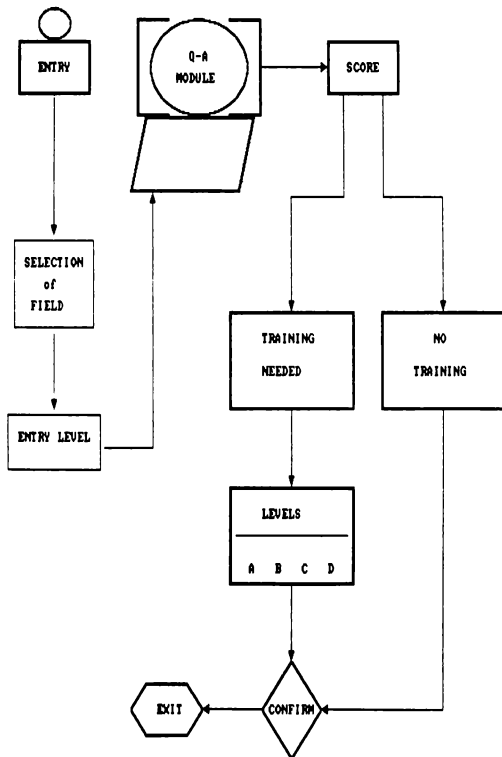

TOWARDS MODERN SYSTEMS

This chapter provides a brief glimpse into the wonder world of modern computer applications to the maritime operational and educational fields.

Present day maritime training focuses its attention on the use of simulators and knowledge based systems. This emerging technology can be studied in 4 sections.

1. Simulators and simulator training in maritime field.
2. Knowledge Based Tutoring systems.
3. Expert Systems in maritime industry.
4. Fuzzy Logic Systems of the future.

8.1 Simulator systems.

" To the management scientist, simulation is a mathematical model that describes the behavior of a system over time. A management scientist uses the simulation model to conduct experiments. By observing the behavior of the model during the experiment, the analyst is able to make inferences about the possible behavior of the real world system"

- Watson & Blackstone

To us, the mariners, simulation is creating a situation close to real life, for the purpose of training and/or analysis of reactions, response behavior and response time. These simulation systems are descriptive models of a specific situation or system which we may come across on board a ship or in a shipping office. This simulation model is created after verification of a number of

variables and it is these variables, shown in Annex 8.1, which will decide the quality of the model.

Simulation Engineering is not a new theory. Even in the good old days, some of the basics we learnt were through simple simulation techniques. We learnt that 5 crows and 4 parrots total to 9 birds, through our fingers representing them. Well, basically that is a simulation model. The difference now is the introduction of scientifically modulated patterns of complex nature mathematically modelled into a computer programme.

The simulation concept is based on actual situations or on the available data of a situation. The simulation ladder is shown in Annex 8.2. The first step is the reality or facts, which are blended with the theories to model the simulation. This stage of development is extremely important for the success of the model. Only a few people understand every aspect of a situation. Theories are therefore developed to focus attention on each and every one of their elements, before the models are conceived. In shipping the models can be made from any situation-technical, commercial, operational or safety. One such model useful for a shipping executive is shown in Annex 8.3. This model is used for simulating voyage plans for making operational plans and decisions. Once this model is available, one can alter any input data and find out the effect on ones decisions.

8.1.1 Training Model of Simulation.

In a training model, the computer or an instructor can feed the data which then interact with the student's input. The interaction takes place in the following way /33/.

1. Trainee requests a particular field he needs to study, or the instructor places the field which the trainee must study.
2. Computer presents the information and flashes questions.
3. Trainee studies information and answers the questions, either by adding text or by giving input to the systems operation. (e.g. starting a pump or turning the steering to the required angle).
 - 3.1. He may ask for clarification if the question is not understood.
 - 3.2. An instructor may intercept at any time for text/graphic presentation or for fault mixing and judging.
4. Computer accepts, analyses and provides feedback.
5. Computer maintains the record of performance.

8.1.2 Maritime Simulators.

A number of simulators are already in use at various Nautical and Marine academies. Some of the types are listed below.

1. Diesel Engine Simulator.
2. Boiler Combustion Simulator.
3. Navigation Simulator.
4. Cargo Simulator.
5. Liquid Cargo Handling Simulator.
6. Bridge Simulator.
7. Hydrographic Simulator.
8. Dynamic Positioning Simulator.

Most of the manufacturers make simulators as per the need of the customers. There is no field wherein a simulator

cannot be made. The main limiting factor is the cost.

8.1.3 Advantages of the Simulators.

Major advantages of the simulator are as listed below.

1. Experience, otherwise dear, can be obtained.
2. Situations, impossible, can be created.
3. Responses, otherwise unknown, can be studied and perfected.
4. Response time can be gauged and improved.
5. Repeated interaction ensures better achievements.
6. Untiring patience and individual attention is possible.
7. Teaching through animated figures make understanding easy.
8. Simulator is available at any time.
9. Penalty of failures are not catastrophic.

This list is not exhaustive. With every advancement in technology, these systems are offering more and more advantages.

8.2. Knowledge Based Tutoring Systems.

In any situation of information processing the most important element is the information itself. Knowledge Based Systems (KB systems), offer an excellent data base filled with information. Even simulators are now being interlinked with such KB systems which enlarge the simulator capacity.

Basically the KB tutoring starts from the OAV (Object-Attribute-Value) technique. The trainee's memory is triggered by the stimuli of the object's condition.

Further knowledge is taken from the computer itself for analysis and decision making. See annex 8.4. The interactive KB tutoring model then takes over. Recall time is an important factor in decision making and the computer comes in handy here. It flashes the attributed values in a split second. This is then passed on to the command-execution center to the front stage where the trainee can access the information. This cycle repeats till the trainee completes his learning session.

In its later stage the KB systems were modified and merged with Intelligent KB systems called Expert Systems.

8.3 Expert Systems - (ES).

Expert systems are the first fruit of artificial intelligence research. Combined with KB systems, they offer us capabilities beyond compare. Though still in infant stages, Expert Systems could be used in the marine field to solve a variety of existing problems. ES has the potential which can combine human-machine interaction and the KB techniques and give flexible and adaptable solutions.

Basic elements of an ES are shown in Annex 8.5.

The ES embodies organized human knowledge concerning a specific area which can be easily accessed by the user through an interface. The relationship between man and the system is usually developed as an ergonomic model. The software is developed to create a static and dynamic condition of the particular situation. Discrete models and continuous models are added to give enhanced use of the system. Depending on the position it may show explicit,

dynamic, continuous conditions or implicit, static, discrete conditions /32/.

Once the ES is developed, it is ready for human interaction. In tutoring systems the Knowledge Base domain has a case library. The rule interpreter communicates with the trainee or user to know the dynamic knowledge of the situation, where he needs the expert advice. This is processed in the KB region with respect to the tutor rules. The structure of the Expert System is shown in Annex. 8.6.

As shipping trends are towards low manning vessels, expertise is going to be rare on board. Here, ES would come in very handy. The handful of people on board can have the backing of a number of experts through ES. Once setup, the ES has the capability of self learning that will identify new relationships not defined previously. This will add new knowledge to the inference engine for future use.

The main advantages of the Expert System, for ship's use may be summarized as below.

1. An expert is available at any time, any where at sea.
2. This expert can remodel new formulations.
3. It flashes decisions very fast.
4. It gives alternate suggestions.
5. It has high reasoning power.
6. It gives smart, clean and logical outputs.

Some of the areas where the Expert System is already used on board ships are given below.

1. Engine surveillance.

2. Collision avoidance.
3. Radar Interpreting.
4. Condition monitoring.
5. Weather forecasting.
6. Simulation.
7. Traffic control.
8. Automatic engine controls
9. Load sensitive power control systems.

8.4 A few words about Fuzzy Logics.

However good the ES may be, it still contains an element of 'uncertainty'. This may be due to various reasons like;

- a. shortage of human experts while collecting data,
- b. inadequacies in KB,
- c. qualitative lack of knowledge,
- d. unreliability of data available,
- e. ignorance of problem and incomplete fault trees,
- f. stochastic relationships between proposals,
- g. and/or presence of "Idiot's Bayes". (See Annex 8.7)

Expert engineers have suggested a variety of qualitative and quantitative techniques for handling this uncertainty, such as the theory of "Endorsements", "Fuzzy Logics" and "Belief Functions".

Once the ES procedures go beyond the probabilistic limits of law, rule and proved theories, the logic becomes more and more vague. The fuzzy logic systems argues that a subjectivists Bayesian view of uncertainty (Cohen L.J) if applied within certain limits can provide many features demanded by the Expert System. Thus the ES can take up a more dynamic role.

Paul Cohen (1985) was taking an approach of "understanding -oriented" rather than "performance - oriented" in developing a plausible model of human reasoning about these uncertain conditions. His theory of "endorsements" was of a non-numeric approach towards fuzzy logics. /10/

Fuzzy logics are developed as solutions to uncertainties such as " I am almost sure", "Beyond reasonable doubt ...", "I have a feeling this is true....", "Both are true". etc. These cases of vagueness are frequent in maritime industry. Hence there is a fair chance that Fuzzy Logic systems will enter the maritime world soon and therefore we have to be ready for them.

-----o-----

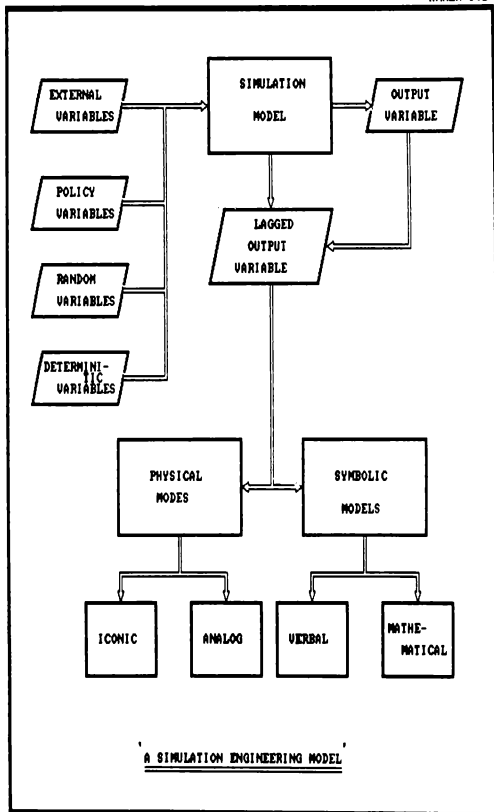

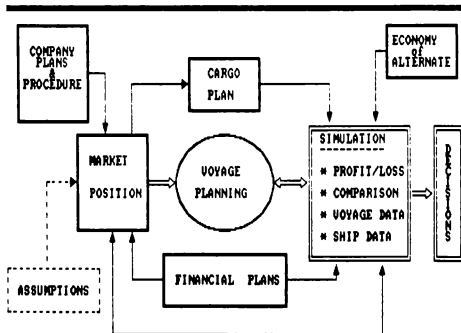
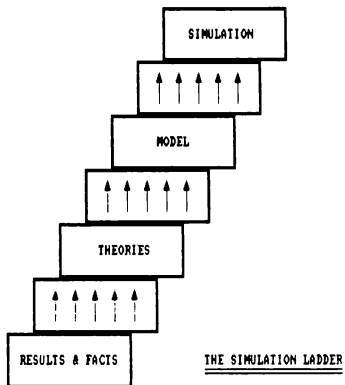

Annex 8.

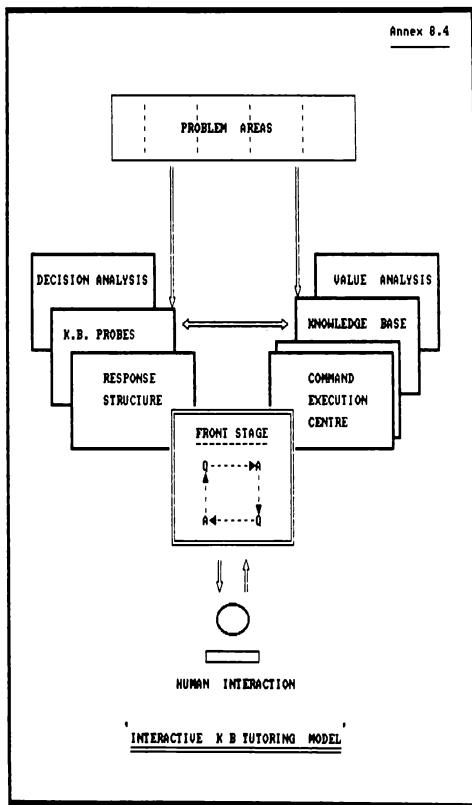

Annex 8.5

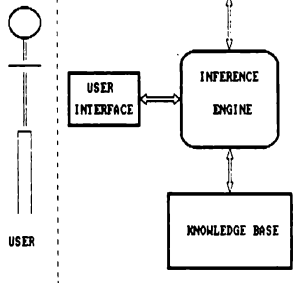

ELEMENTS OF AN EXPERT SYSTEM

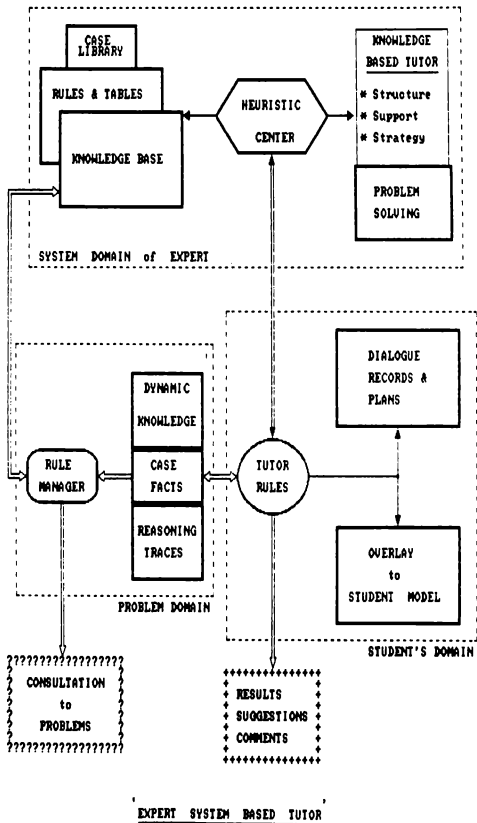

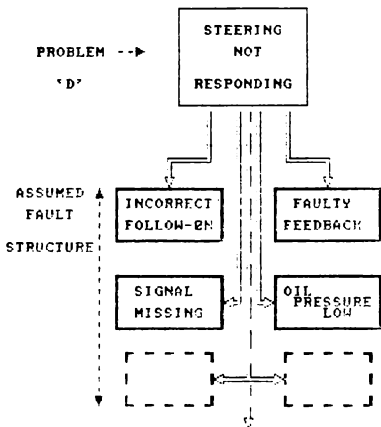
IDIOT'S BAYES

The calculation of posterior odds of problem $D = d_1, d_2, d_3, \dots, d_n$ given to the realized symptoms $S = s_1, s_2, s_3, \dots, s_n$ is simply,

$$\frac{p(d_1/S)}{p(d_n/S)} \quad \text{and this}$$

technique is occasionally called Idiot's Bayes. This final probabilities $p(d_i/s)$ often tend to be too extreme due to ignored system correlations.

Ref: Cohen, L.J, Bayesianism & Baconianism in evolution of medical diagnosis.

SPECIFIC NEEDS of SCI and MTI

The Shipping Corporation of India has grown rapidly in the last fifteen years, towards diversification and expansion of the fleet. Due to a number of reasons the manpower development didn't keep pace with this growth. This was identified and the Maritime Training Institute was set up. Training activities were then boosted up. But the manpower problem was persisting, because of the high exodus of trained personnel. At the same time there were changes in the technology itself. Hence, there was a two fold need to improve the training schemes and update the existing ones; one to bring up the people to the higher level of sophistication and the second to fill the void created by the outflow of personnel.

This responsibility of training the Indian maritime personnel was entrusted to MTI. The combined effect was to increase the training load tremendously. We needed an efficient method to cope with these high training requirements. Further, the entry of computers into shipping resulted in additional need for training the personnel. To find an equitable solution to these problems introduction of computers for training purposes appears to be a must.

This means that MTI now has to improve the existing setup and make arrangements for modern training methods by using the computer based systems, and the faculty must be made conversant with these modern systems.

9.1 Present Training methods

The system of imparting training at present is the good old method of "chalk and talk". Use of overhead and 16mm slides are normally left to the discretion of the faculty.

The syllabus exists and lecture contents are prescribed. Still it can be seen, as in many teacher oriented systems that teaching is what the teacher knows, rather than what it is supposed to be. This goes on without evaluation of the actual need of the course or the organization or for that matter the need of the participant. In certain mandatory courses, we can insist that the lecturer speak on the most important points without fail. But this also does not guarantee that he is going to speak on these points as is needed. When it comes to a developmental type of course, the problem may be totally different.

It was also noticed that in the existing system, with some of the faculty, there is a tendency for repeating what another faculty has already taught. The result is the need of extra time for completing the lecture.

On the practical side, the so called "hands-on" is done at MTI in courses like survival at sea, fire fighting and marine automation course. Here the participants perform the deeds to the satisfaction(?) of the trainer.

Thus, the evaluation is also not a fool proof method. In other courses evaluation is done by a test or a simple questionnaire. This, in most cases does not give the correct measure of the system and its effectiveness; not does it provide effective feedback for course improvement.

The class lectures are oriented towards the general

average understanding of the group. Individual attention in many cases is impossible due to:

- difficulty in identifying ones level of absorption
- time constraints to finish the portion and
- the passive atmosphere.

Computer systems can overcome these difficulties since the evaluation can be done simultaneously with the teaching progress in a more dynamic atmosphere. In the case of the lecture oriented systems, the lecturer can make the sessions more lively with better audio-visual aids made by using computers. CAI and CBI methods normally catch the students attention and keeps the interest on the subject.

Yet another point to be seen in the case of MTI is the teacher to student ratio, which is very small. Computer based systems are advantageous in such cases. The present number of teaching staff available at MTI is only 19 compared to the student population of over 5000.

Further, the faculty at MTI is involved not only in teaching, but also in administrative work connected with the courses. They also have to spend time in non-technical type of work such as arranging the class room, getting the course material ready, etc.

"How often must it happen that we disregard a potentially valuable medium or method because we were unaware it was available to us? All too often we choose from among the media that we were taught by ourselves or that we have used successfully in the past. Ideally, we should be regularly examining reports of how media new to us have been used."

- Derek Rowntree (1981)

This is true at MTI or for that matter at many other institutions. It takes time and effort to change and try out newer and better methods. Since the entry of computers, we have a powerful medium available to us which can be used in training and thus improve the productivity.

9.2 Requirements at MTI

In order to use these wonder machines effectively, some of the areas of application as given below have been identified. Each of these areas are discussed further in brief below.

1. Computers in MTI administration.
2. Setting up simulator training facilities.
3. Developing and conducting courses on
 - a. Teaching about computers.
 - b. Teaching with computers.
 - c. Computer applications in shipping.
 - d. Computer application in general.
 - e. Programming languages.
 - f. Maintenance and care.
4. Using computers for production of courseware.
5. Developing educational programs, self teaching systems and expert systems for ship's use.
6. Updating existing courses using computers.
7. Initiating computer training for seafarers.

Use of computers for administrative purposes was described in an earlier chapter.

The need of modern maritime education is to develop human resources capable of handling all aspects of ship operation. A mariner now must possess skills of navigation, ship-handling, communication, management,

languages, life saving, knowledge of electronics and technical subjects. Simulators are already tested out and proved worthy in these fields. SCI is already planning to procure a number of simulators and setting up the training facilities. This project should be speeded up in order to take advantage of the new technology.

Complimentary to ship staff, the shore staff must be knowledgeable in ship operations, port operations, international regulations, market conditions and many other things. We have already seen how computers can be used in these areas. Hence different types of courses will have to be developed in order to train different class of people. The class of people was discussed earlier as target population.

Some typical examples of courses in computers are discussed below.

A general course on computers, what it is and how it is used, can be catered to all. How much information is to be given in these courses will depend on the knowledge level of participants. The secretaries and typists need a course on word processing while it would be beneficial to teach the accounts staff in spread sheets. Data base programs are ideal for librarians, operators of data centers, MIS department, personal departments etc. Faculty of MTI must undergo a course on how to use computers in education and courseware production.

In order to appreciate the advantages of these courses let us now look into the benefits of a word processing program which are given below.

1. It makes typing easier and typists are more willing to

- use computers than even the electronic typewriter.
2. It is easier to browse through the text.
 3. They have a large vocabulary in the computer memory for ready use at any time.
 4. Writing speed is high once the user is familiar.
 5. It gives neat output.
 6. Less time and effort to correct or to alter or manipulate the text.
 7. Any number of copies can be made at any time without retyping the whole matter again.
 8. During review and corrections, no new errors are introduced as in the case of manual typing.

Some courses on programming language would be an added advantage. Many a seafarer or an assistant in a company is known to have produced simple but effective programs with languages like BASIC or PASCAL, thus creating expertise within.

Computers can be used for making audio visual teaching aids, course materiel production and even for producing slides and films. This would need setting up of a courseware production room fitted with drafting facilities, computer connected camera systems and a desk top publishing unit.

Existing courses can be given a face lift by using computers. For example, in our cost control in shipping we teach the participants how to find out the quantity of fuel to be bunkered at a particular port. This is a complex problem which depends on a number of variables like bunkers left on board, capacity, consumption, availability at a port, bunker supply cost, bunker cost, delays, re-routing and other voyage criteria. It involves a series of calculations before the answer is arrived at.

A simple program made for computing these, is valuable not only in the training situation, but also in the actual bunker procurement situation. Likewise, simple programs in areas of ship operation and management can be made at MTI and can be given to the line officers, while the same can be used for training also.

So far, there are no steps taken to train the ship staff in computers, though a number of computers are operational on board ships. Hence these courses must be developed as fast as possible.

Gains as far as the participants are concerned are listed below.

1. Communication skills- written and spoken- are sharpened which makes them more receptive.
2. They can transfer experiences to simulation models and simulation models to experiences. This makes them see the similarity and contrasts when comparing the ideas, objects, processes or situation related to shipping.
3. They can locate, match, evaluate and categorize information to critical and non- critical areas.
4. They can interpret, criticize, and analyse graphical and statistical information which is essential in shipping.
5. They can synthesis information and seek to improve organizational and problem solving skills.
6. They can search and obtain expert advice where an expert may not be available.
7. Time consuming routines and rigorous calculations can be simplified.

9.3 Suggestions and Proposals

Most of the pervasive educational and operational problems in the shipping industry can be solved by using computers. The participants would be more than willing to improve their skills, abilities and knowledge with a CAI/CBI program than with the conventional system. To implement this, some suggestions and proposals are given below.

- A. Enhance present existing facilities at MTI. Existing computer lab must be fitted out with 10 PCs, out of which 2 must be PC-AT and the rest PC-XTs. Two DOT matrix printers and a color printer along with other related equipment for training purposes are needed.
- B. Install a PC for administrative use.
- C. Equip the library with related books and periodicals.
- D. A data base also to be developed at MTI. This data base at a later stage can be linked up with data bases at nearby educational institutions like NITIE, IIT and Bombay University. This will automatically enhance the research facilities in MTI.
- E. Procure some educational software programs. See list attached (Annex 9.1).

To implement these things in a systematic and orderly way it is suggested to form a computer science section at MTI under a separate Dean. The supporting team must be comprised of an engineering faculty, a navigation faculty and a computer programmer, one artist cum draftsman, a lab technician and secretarial assistance.

This will ensure effective utilization of resources. This section can work as a "think tank" of MTI and develop creative programs. With the assistance of the computer programmer, we can make a number of software programs which would be useful to the ship operator. One such area is a self learning computer session program for the ship staff. Before they join any ship, they are to undergo this program instead of (or over and above) the existing system of 'briefing'. This would make them more familiar with the ship they are going to join and also with the typical problems on board. Similarly, the need of preparing proper repair specification can be taught by computers. A typical specification can be generated by the computer and the disk can be sent to the ship wherein the ship staff fills in the blanks or adds items as required. The complicated list of surveys, classification requirements, IMO regulations also can be put into an expert advisor and sent on board. Technical diagnostic systems can also be made through expert systems for ready use on board ships.

In addition to the above, it is suggested that computer science be included as part of the course curriculum for any entry level officer on board ships. In the USA, they give 3 to 4 credits out of the 18 credits of every semester for computer education in their Marine Engineering course, Nautical Officer course, Naval Architecture course and even in the Ship Administrator course. This is an essential requirement for any one before he obtains his licence for a sea career.

In countries like France, Norway, UK and Germany, all the courses including Maritime law and Shipping Management have 16 to 20 credits out of 72 credits in the 4 years.

Computer Science is also a must for all MOT/DOT examinations and in India also it must be included so that our maritime personnel stand at par with their counterpart in other nations.

It is also suggested to develop a data base within SCI and MTI on the following areas.

- i. Ship particulars
- ii. Ship casualties and investigation.
- iii. IMO rules and regulations and frequent updates.
- iv. Classification requirements.
- v. Technical information.

These data bases, probably on the main frame, must have search and scan functions for easy data retrieval.

And finally, computers and automation are rapidly changing fields. No one expects the scene to remain static. Our aim should be to know what it is today and then get ready for tomorrow. To conquer the new tomorrows, we have to be dynamic in learning the new technology as it emerges.

A state of art situation is presented in these chapters. Upgrading the training systems and the use of modern equipment will help us to produce competent ship operators and ship managers. Possibilities are tremendous. All that is required is imagination, willingness to do some thing good, creativeness and of course, the support of the management.

---o---

List of Resources to Educational Computing

1. Association for Education Data systems (AEDS)
1201, 16th street, N.W, Washington DC 20036.
2. National Council of Teachers of Mathematics
1906, Association Drive, Reston, VA 22091 USA.
3. Byte, c/o Macgraw Hill Publications
4. Dept of Computer & Information Science,
University of Oregon, Eugene, OR 97403, USA
5. EDCOMP Incorporatin, P O Box 535, Cupertino, CA 95015.
6. Educational Computing, Ockfield House, Ferrymount Road
Haywards Health, Sussex RH 16 3DH England.
7. IBM corporation
8. Tata Consultancy Services, Bombay, India
9. Videotel Marine International Ltd., Ramillies House,
1/2, Ramillies St., London W1V 1DF.
10. Poseidon Simulator Systems ltd, UK.
11. Sea Information Systems c/o Videotel, UK.
12. "Examiner", Media Computer Enterprises ltd., 880, Sibley
Highway, Suite 102, Mendota Heights, MN 55118, USA.
13. CATS-Computer Assited Teaching Systems,
Intercollegial Consortium for Software Development,
PO Box 2000, St-Anne-de-Bellevue, Quebec, Canada H9X 3L9.
14. CELCAT from, Corbett Engg ltd., 1 Ashfield Road,
Kenilworth, Warwickshire, CV8 2BE UK
15. NOR control Simulation A/S, P O Box 1024,
N-3191, Horten, Norway.
16. Radio-Holland BV, Jan Rebelstraat 20, 1069, CC Amsterdam.
17. MARIN, Haggstøeg-2,
P O Box 28, 6700 AA Wagenwigen, Netherlands.
18. Bharat Electronics ltd, Simulator Division,
Jalahalli, Bangalore, India.
19. SEAFUEL, Shell SEatex, MRT/3, Shell Center, London SE 7NA
20. Massachusetts Institute of Technology, Massachusetts USA

21. Experttech Ltd., Experttech House,
172, Bath Road, Slough, Berks, SL1 3XE.
22. Intelligent Environments, 20 Crown Passage,
St. James, London SW 14 6PP
23. Texas Instruments, Manton Lane, Bedford, MK 41 7PA.
24. ISI, 11- Oakdene Road, Redhill, Surrey RH1 6BT.
25. System Designers, Pembroke House,
Pembroke Broadway, Camberly, Surrey.
26. ICL, Wenlock Way, West Gorton, Manchester M12 5DR
27. AIL, Intellegent House, Merton Road,
Watford, Herts, WD1 7BY.
28. Intellincorp, Runnymede Malthouse,
Runnymede Road, Egham, Surrey TW20 9BO
29. Inference Corp. c/o, Ferranti, Ty Coch Way,
Cwmbran, Gwent, NP 44 7XX
30. Goldhill Inc. c/o AIL, Herts
31. Presentation Products, Pacific Magazine Group Inc.
513, Wilshire Blvd, Suit 344, Santamonica CA90401.
32. Mitsubishi Electronics, Tokyo, Japan.
33. Matrix Instruments Inc., One Ramland Road,
Orangeburg, NY 10962. USA
34. University Associates Inc., 8517. Production Av.,
San Diego, CA 92121-2280.
35. Management Graphics, 1401 East 79th Street,
Minneapolis MN 55425
36. Casio Electronics, Japan.
37. Sharp Electronic Corp. Japan.
38. CACI Products Co., 3344, North Torrey Pines Court,
La Jolla, California 92037.
39. Radio Shack, Educational Div. 1400, Tandy Center,
Fortworth TX 76102
40. Phonix Performance Systems, Stillwater, MN, USA
41. Aldus Corpn. 411 First Av. Seattle WA 98104.

CONCLUSION

With all the benefits of CAI, I am not suggesting to remove the tutor or lecturer entirely from the educational system. It is not only the technology or knowledge that is learnt from a teacher but also a number of social and environmental impacts. Jackson, in his book "The teacher and the Machine", says, "the teacher is in constant attendance, he is available not only to call attention to errors and to affirm correct responses, but also to beam with pleasure and to frown with disappointment." He continues that only human's care about humans, machines never do.

While the computer is good for massive information processing, it is devoid of the human touch. This humanist way is supported strongly by Gagne in many of his books and articles. The course designer must remember this while designing CAI and CBI programs.

Heuristic approaches of conversational programs and mimic graphics can be used to a certain extent to give a little human touch to computer instructions. On the other hand if you look at the teacher oriented systems, you find that many teachers use operation oriented or route learning oriented methods, mainly because they learnt it that way. Some times this is because they don't have the skills necessary to use interactive dynamic methods. This is the greatest justification for a well conceived and developed computer instructional program.

It may also be noticed that the present society demands highest mass education. There is a demand for highly trained

and qualified teachers. But such high caliber people are always in short supply, especially in the maritime education field. There are a good many people who are capable of being good lecturers, but they tend to move towards other operations especially because of the career prospects, financially and status wise. There is very little motivation and encouragement given to the people who select maritime education as their career. More often it is considered that training is a waste of money. But in reality it must be considered as a good investment. Hence there is an urgent need for improving the attitude towards maritime education and training.

It is equally essential to have highly motivated people in training in order to ensure quality of output. The teachers must be carefully selected and trained to deliver the goods. They should also be exposed to new technologies and systems. Training and re-training of the trainers is more important than the normal training. They must also be trained in the use of computers.

"People perform adequately only if their task is suited to the capabilities, limitations, attitudes and needs inherent to human nature" and only if they are provided with the right tools and right atmosphere. There should be a gain designed into the system. Only then can the performance reach higher standards.

Computers as an educational tool.

Alfred Bork, from University of California, a leader in the area of computers in education, once wrote in "Creative Computing", a popular magazine, "computer is the most powerful new learning device since the invention of printing

press and books. Computer has potential to solve most of our current educational problems. Within twenty years computers will be the major delivery system for education at all levels and in practically all subject areas."

But why is it taking time for the computers to enter into maritime education? Basically the reasons are;

1. Difficulties involved in expecting any real change to occur in the established teaching and existing learning procedures.
2. An inappropriate and unproductive view of the computer as an educational tool itself.
3. Teachers prefer their styles and the system remains in the established teaching/learning styles.
4. Resistance to accept new things.
5. Familiarity of old routines. Teachers tend to become complacent, comfortable in the independence of their class rooms and perhaps over confident about the effectiveness of their routines. It is difficult for many to leave the model of teaching which they know best and consider to be reasonably efficient and effective.
6. Question of 'who will bell the cat' and the fear of most teachers being labeled as students as far as computers are considered.

The best way to make the change would be to make people understand and feel the need rather than impose the change. It is a good way not to use the "employability" argument.

With respect to training, it must begin with "where teacher is at" before "where students are at". That is to say that the teachers must be trained first.

It takes time, effort and discrimination from the higher ups in any organization to implement these new technologies. But the time and effort spent initially will pay off very soon and in many ways.

Shipping corporation of India being one of the leading shipping firms in the world has the need to keep abreast of the latest. Education and training has been a prime policy of the management. To improve the existing systems, we would need computers in every field and personnel well trained in computers. Some of the suggestions and proposals for this are included in the previous chapter and it is felt that SCI management will definitely consider them for implementation in the future.

THIS IS NOT THE END

* * THE VOYAGE TOWARDS EXCELLENCE HAS JUST BEGUN * *

BIBLIOGRAPHY

1. Allan H. Miller - Course design for University Lecturers (ISBN -1-85091-277-7)
2. Alessi S.M. & Trollip S.R (1985) - Computer based instruction
3. Anastasi A. (1968) - Psychological testing 3rd edition.
4. D.H.Archer & G.Marshall- BMT. UK - "Preliminary ship design -A rational approach using micro computers", CADMO conference 1988.
5. Betty Collins - Computers, Curriculum & whole class instructions - issues and ideas
6. Blisshen.E - Blond's Encyclopedia of Education
7. Bruner J.S. (1960) - The process of education
8. Dr. D.Carcaillet - "Real size simulation on board ships: interest - limits", Sapanaut issue volume 18 no 1, 1990
9. D.M.Cleal & N.Heaton - Knowledge based systems- Implication for human-computer interfaces (ISBN-0-470-21082-6)
10. Cohen P.R. (1985) - Heuristic Reasoning about uncertainty - An AI approach
11. Colin Godfrey - "Computer Application for shipping" BIMCO Bulletin 2/90 March/April
12. Daniel Hunt. V - Mechatronics, Japan's Newest Threat. Published by Chapman & Hall (ISBN 0-412-01441-6)
13. David H.Jonassen (Editor) - Instructional designs for micro-computer courseware
14. Davies I.K. - Objectives of Curriculum Design
15. Daves.K - Behavioural Objects in science teaching
16. Derek Rowntree (1974) - Educational Technology in curriculum development (ISBN
17. Derek Rowntree (1981) - Developing courses for students (ISBN -0-06-318343-9)
18. Capt. U. Fuchs. FRG - "The project 'Ship of the Future' Paper presented NorShipping '85 conference.

19. Gagne.R.M. - Essentials of learning and teaching
20. Gavriel Salvendy (Edited) - Handbook of Human Factors.
(ISBN -0471-06015-9)
21. Gunther Zade - "The importance of modern technology"
-L'Automazione Navale issue 1989
22. Hugh Watson & John Blackstone Jr. - Computer Simulation
23. R.F.Hansford (Racal Marine Systems) - "Integrated Ship
Electronic Systems", presented at Europort confer.'85
24. G.F.Hudson, R.A.Johnson & D.P.Laurence - Integrated Ship
Management & Instrumentation
25. P.B.Joshy & Dr. K.B.C.Saxena - New type of computer
software for voyage estimating, Assian Shipping-Feb '89
26. John Niman - A teachers companion to micro computers
(ISBN -0-669-06267-8)
27. D.T. Jones (USCG) - "Human Error", Marine Safety Council
proceedings April 1982
28. P.S.Katsoulakos & C.P.W. Hornsby & R.Zanconato -
DEEDS -The diesel engine expert diagnosis system
Maritime Communications & Control conference Oct. 1988
29. Morris L.Bigge - Learning Theories for teachers
(ISBN 0-06-040673-9)
30. Mike Edelhart & Douglas Garn - The Complete Computer
Compendium (ISBN -0-201-10437-7)
31. T.K.S.Murthy, J.C.Dern & G.J.Goodrich (Editors) -Marine
and Offshore Computer Applications (ISBN -1-85312-019-7)
32. J.K.M.Nair - "Electronic Seafaring and Expert Systems"
paper presented at I.Mar.E National convention Sept 1988
33. J.K.M.Nair - "Simulation Engineering an Expert tool for
training," paper presented at the national convention
of Marine Engineers Dec 1987 and published in the
transactions
34. Oakes.J.Schneider.M - Computers in Classroom
35. H. S. Osborn - Design of selection & training systems
36. Per Larsen, (DNV) - "Integration : the philosophy"
Ocean Voice issue July 1989

37. Prien.E.P. (1977) - Function of job analysis in context validation in personal psychology.
38. A.J.Romiszowski - Producing Instructional Systems (ISBN -085038-224-6)
39. N.J.Rushky (Edited) - Computer based learning.
40. Sholom. M. Weiss & Cassimer A. Kulikowski - Practical guide to Building Expert Systems (ISBN -0-412-26450-1)
41. Stephan. M. Alessi & Stanley R. Trollip. Computer based instruction - Method and Development.
42. Tocci.S (1981) - Micro-computer biology interface-science teacher
43. Tony Droar (Edited) - Computer controlled interactive video, (ISBN 0-291-39722-0)
44. Tony Earl - Art and craft of Course Design
45. Tinker R. (1984) - "What is computer literacy-Hands on". Newsletter of the Technical Education Research Center
46. Wilbert J.Mc Keachie - Teaching Tips (ISBN 669-06752-0)
47. William A.Gale (edited) - Artificial Intelligence & Statistics.
48. William J. Clancey - Knowledge Based Tutoring - The GUIDON program (ISBN -0262-03123-X)
49. Computer Basics- Understanding computer series by LIFE & TIME magazine (ISBN -7054-09104)
50. Corporate Plan of SCI in time perspective of 2000 AD.
51. "Development of an Intelligent Ship", - Schiff & Hafen/Kommandobrake issue Heft/1989
52. "Expertise at your finger tips" Engineering issue Jan 1989.
53. "Ghost in the machine" - Ocean Voice issue July 1988
54. Indian Shipping in perspective of 2000 AD - a report of planning group on shipping, Govt of India Sept 1987.
55. International Trade Union Training Hand Book
56. Regional report of India - DNV Bulletin April 1989.