

World Maritime University

The Maritime Commons: Digital Repository of the World Maritime University

World Maritime University Dissertations

Dissertations

1990

Training course for marine officers on diesel engine room simulator at the Maritime Academy...

Charles Louho Gbayoro
WMU

Follow this and additional works at: https://commons.wmu.se/all_dissertations

Recommended Citation

Louho Gbayoro, Charles, "Training course for marine officers on diesel engine room simulator at the Maritime Academy..." (1990). *World Maritime University Dissertations*. 1016.
https://commons.wmu.se/all_dissertations/1016

This Dissertation is brought to you courtesy of Maritime Commons. Open Access items may be downloaded for non-commercial, fair use academic purposes. No items may be hosted on another server or web site without express written permission from the World Maritime University. For more information, please contact library@wmu.se.

WORLD MARITIME UNIVERSITY
MALMÖ, SWEDEN

TRAINING COURSE FOR MARINE OFFICERS ON DIESEL ENGINE ROOM
SIMULATOR AT THE MARITIME ACADEMY OF
MARITIME SCIENCE AND TECHNOLOGY
ABIDJAN, COTE D'IVOIRE

BY

CHARLES LOUHO GBAYORO
COTE D'IVOIRE

A paper submitted to the faculty of the World Maritime University in
partial fulfillment of the requirements for the award of a :

MASTER OF SCIENCE DEGREE
in
MARITIME EDUCATION AND TRAINING
(MARINE ENGINEERING)

The contents of this paper reflect my personal views and are not
necessarily endorsed by the University.

Signature: 

Date: 30 October 1990

Supervised and assessed by:
Charles E. Mathieu
Professor, World Maritime University



Co-assessed by:

Jerzy Listewnik
Associate Professor Maritime University, Szczecin, Poland
Visiting Professor, World Maritime University

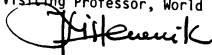

Louho Gbayoro Charles

SIMULATION TRAINING COURSE

AT THE REGIONAL ACADEMY

OF MARITIME SCIENCE

AND TECHNOLOGY, ABIDJAN

COTE D'IVOIRE

CONTENTS

CHAPTER.....	PAGE
1. ABSTRACT.....	iv
2. ACKNOWLEDGEMENT.....	v
3. PREFACE.....	vi
4. INTRODUCTION.....	1
CHAPTER 1 : THE EXISTING EDUCATION AND TRAINING SYSTEM FOR MARINE ENGINEERS IN COTE D'IVOIRE.	
1.1 - Background.	2
1.2 - Present Facilities and Practical Training.	7
1.3 - The International Convention on STCW 1978.	19
CHAPTER 2 : DIESEL ENGINE SIMULATOR TRAINING COURSE FOR MARINE ENGINEERS AT ABIDJAN ACADEMY.	
2.1 - Introduction	31
2.2 - Purpose	33
2.3 - Simulator Process by Computer Techniques	44
2.4 - Description of the Engine Room Simulator	50
2.4.1 The Control Room	50
2.4.2 Instructor Room Console	53
2.4.3 The Distributed Processing Computer System	54
2.4.4 Sound Generator	54
2.4.5 Printers	54
2.4.6 A Central Processing Unit Panel	55

2.4.7 Power Source Panel	55
2.4.8 The Engine Room Graphic Panel	55
2.5 - IMO's Work on Marine Simulators	59

CHAPTER 3 : TRAINING COURSE PROGRAM FOR MARINE ENGINEERS
AT OTHER MARITIME INSTITUTIONS.

3.1 - I.M.O's ROLE AND MODELS OF TRAINING	63
3.2 - Maritime Education And Training In The F.R.G.	65
3.3 - The Polish Training Model	69
3.3.1 Proficiency and Updating Courses In Poland	71
3.3.2 Academic Staff Qualification	72
3.3.3 The Outlook For Training Systems Of The East European Countries.	73
3.3.4 Conclusions	75
3.4 - Maritime Education And Training In The U.K.	77
3.5 - Maritime Education And Training In The U.S.A	80
4 : PROPOSAL FOR ENHANCING THE USE OF EXISTING FACILITIES.	87
4.1 - The Transfer of Shipping Technology to Developing Nations.	87
4.2 - The International Framework.	90
4.3 - The Impact of the STCW 1978 Convention.	91
4.4 - Proposals For Enhancing The Use Of Existing Facilities	93
4.4.1 Objectives	95
4.4.2 Simulator Training Course.	97
4.4.3 Instructors.	99
4.4.4 Execution of Training.	99

4.4.5 Implementation and Evaluation of Simulator Training Course.	107
4.4.6 Importance of Providing Specialized Maritime Short Courses as an Aid to Improving Standards.	108
CHAPTER 5 : CONCLUSIONS AND RECOMMENDATIONS.	111
5.1 - Conclusions.	111
5.2 - Recommendations.	114
APPENDIXES:	
Appendix -A- FRG.	116-124
Appendix -B- USA.	125-129
BIBLIOGRAPHY.	130-131

ABSTRACT

Due to the introduction of ships designed for specialized commodity transport, the rapid increase in application of advanced technologies, the compliance with new or amended international legislation on marine safety and environmental protection and the revision of shipboard organization as a result of manning reduction, there is a persistent need for facilities to adapt the level of knowledge of individual crew members in order to fit the functional requirements and to perform the tasks assigned to them safely and efficiently.

This paper discusses the use of a diesel engine room simulator as a training aid for the education and training of marine engineers at the Maritime Academy, Abidjan, Cote d'Ivoire. This facility can be a useful means of bridging the growing discrepancy between the knowledge and skills acquired through earlier education, training and experience and the knowledge, skills and possible experience required to fit specific new requirements, providing information material tailored to the actual onboard situation is made available, thus opening the way to what is called permanent education.

To help the interested reader fully understand the best use of such a facility, I have highlighted some advantages of using simulators and recommended an improvement of the courses conducted through the Academy to follow technological changes with regard to national and international requirements.

ACKNOWLEDGEMENT

In the preparation of this study, the author owes his sincere gratitude to all those individuals who provided the information which made this study possible.

The author is very grateful for the endless efforts of Mr. Jerzy Listewnik and Mr. Randall R. Fiebrandt who guided the preparation of this study from the start to the final stage.

Special thanks go to Mr. Bouriel, IMO/UNDP Representative at the Maritime Academy in Abidjan, who played a very important role in coordinating the administration of the author's sponsorship at World Maritime University. In particular the author thanks Mr. SOGODOGO, Director General at the Maritime Academy who kept a smooth coordination between the author and his family in Cote d'Ivoire throughout the period of study.

The author deeply appreciates the sponsorship of his studies at the University by the UNDP.

Finally, the author thanks his children for putting up with being away from their parents during these two years and his wife for her support in writing this paper.

PREFACE

It is a requirement of the degree of Master of Science (M.Sc.) in Maritime Education and Training (Engineering) that the students enrolled for the two year course in this field, prepare a thesis on some aspect of their country's needs in the Maritime field. I have chosen to critically examine the use of a diesel engine room simulator as a training aid for education of marine engineers at Abidjan Academy, Cote d' Ivoire. This facility can be used in the training of those marine engineers who are operating the ships.

Based on my own experience gained through field trips during these two years at the World Maritime University, I would like to express my views and give my opinions and suggestions on the subject. In trying to examine the subject, I decided that the writing sequence of the content of my thesis will be the answers to the following questions: Who needs to be trained? What for? And how? The main aspect of each question are explained in the following chapters.

CHAPTER 1 deals with maritime education and training in Cote d' Ivoire. Consequently, when utilizing a diesel engine room simulator, the entry qualifications of the trainees have to be taken into consideration. The training system and the means used to ensure proper maritime training are described. There are three main practical training aids for marine engineers. Two of them, laboratory workshops and training vessels, are mentioned, while the third is the diesel engine room

simulator, as described in detail in the next chapter. World shipping is increasingly having to operate within a voluntary framework of international codes, conventions and other instruments developed through the United Nations and its specialized agencies. However, the convention which has the greatest relevance to maritime training is the STCW 1978 Convention of the International Maritime Organization. A brief review of this Convention, with more details as to training of marine engineers, is also provided.

CHAPTER 2 discusses the diesel engine room simulator. Maritime training institutions all over the world use such simulators, and they have discovered many special merits in them. consequently, this chapter points out the main advantages of using this simulator in training, illustrated with examples. The use of mathematical models in marine simulation has given an added dimension to further development in diesel engine simulators. This chapter also gives a general insight into the process of simulation of diesel plants by computer techniques. The description emphasized in this chapter is the third question of those mentioned earlier. The most popular diesel engine room simulators are described.

CHAPTER 3 deals with the simulator training course. Programs are implemented in order to achieve the objectives of the training. Further details are pointed out regarding the execution of the simulator training course. The tasks, responsibilities and qualifications of the instructors are discussed. In general, the main elements affecting the simulator training course

effectiveness are mentioned.

CHAPTER 4 contains proposals for further improvements.

CHAPTER 5 ends with suggestions made as an academic exercise, trying to apply principles learned to the real world situation. It is not claimed that the suggestions and recommendations provide a perfect solution. However, they could serve as valuable guidelines in the years ahead, particularly in the event that a decision is taken to install a simulator.

INTRODUCTION

In January 31, 1986, an engine room simulator was put into operation at the Maritime Academy of Abidjan, Cote d'Ivoire, for the training of marine engineers.

The simulator was developed by IHI (Ishikawajima Harima Heavy Industries Co. Ltd., Japan), Engineering Department, Marine Consulting Division International.

The main reason for its development was to obtain a facility that could be used in the training of marine engineers in the safe and economic operation of diesel engine machinery.

So far a large number of courses have been conducted in which many graduates participated.

This paper discusses the simulator and the training programme. The effectiveness of simulator training being carried out now is briefly described. An emphasis has been put on a few M.E.T.(E) systems adopted in some developed countries.

The final section of this paper provides the reader with proposed solutions for the improvement of the Marine Engineer Education and Training course with regard to technological changes and international requirements.

THE EXISTING EDUCATION AND TRAINING SYSTEM FOR
MARINE ENGINEERS IN COTE D'IVOIRE

1.1 - Background

Cote d'Ivoire is a maritime country located in South West Africa between:

- Ghana in the East.
- Liberia and the Republic of Guinea in the West.
- Burkina-fasso and the Republic of Mali in the North.
- and finally the Atlantic Ocean in the South.

It has a population of approximately 10 Million.

This geographical position of Cote d'Ivoire makes the country a powerful "maritime" nation. Vessels from all over the world enter the port of Abidjan. The country depends on maritime transport for most of its economic activities.

As a matter of fact, 90% of the country's external trade is carried by sea. This, therefore, shows the extreme necessity for this country to establish a very highly developed port infrastructure of its own, and a national merchant fleet adjusted to a diverse variety of traffic which corresponds to its external trade.

Enormous efforts have been made by Cote d'Ivoire to have a very developed port infrastructure comprising two national

Africa

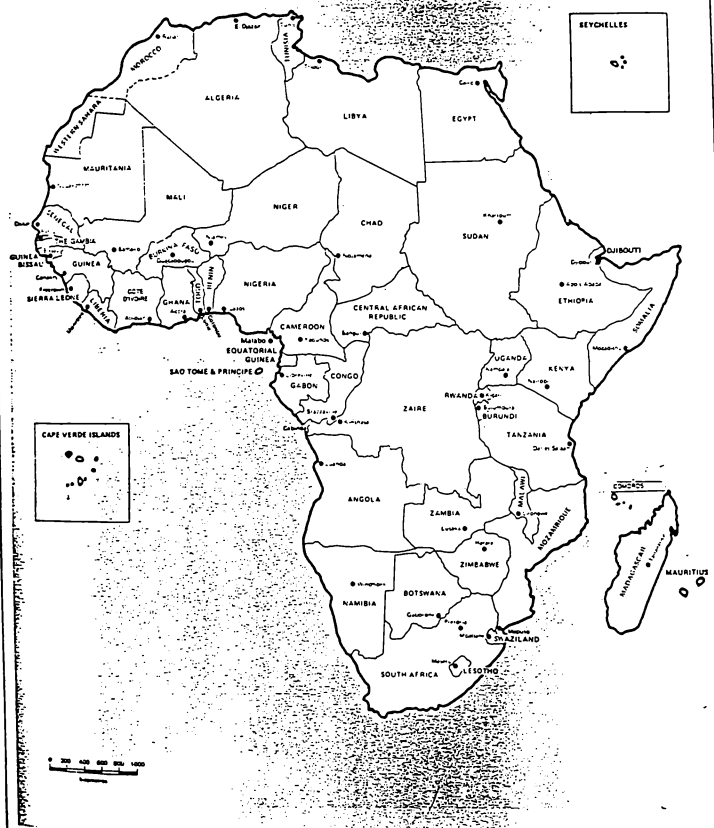

ports: SAN-PEDRO and ABIDJAN.

The number of ships calling on these ports has increased tremendously in these two decades. This is mainly due to the increased use of the port of Abidjan by land-locked countries (Mali, Burkina-Fasso and Niger). They use the Abidjan port for their imports and exports. (See Figure 1).

Due to the increase of shipping activities in the country, an urgent programme of development was set up by the Government, which involved the national fleet with an appropriate Maritime Administration under the auspices of the Ministry of Transports (now under the Ministry of Defense). Cote d' Ivoire established its own National Shipping Company namely, "SITRAM" (Societe de Transports Maritimes) to be able to gain self-reliance vis-a-vis its principal foreign partners. The country exports mainly coffee, cocoa, bananas, etc. This caused the country to purchase specific vessels for this kind of trade.

But the manning of all the ships was carried out mostly by foreign officers with the exception of the ratings who were chosen among Ivoirians with little or no sea experience. The need for training Nationals as seafarers was imperative and a few selected candidates were sent to well reputed maritime institutions abroad.

The rapid expansion of the National Fleet forced the Government into a decision to establish a National Maritime Training Institution.

Maritime training in Cote d' Ivoire originated in 1957 with the establishment of a maritime training center under the auspices of the Maritime and Lagoon Fisheries Service.

On 31st July, 1970, under Convention N.12/LE/FONDS/CA/70, signed by the Governments of the Republic of Cote d' Ivoire, the Republic of Togo and the People's Republic of Benin, the school was regionalized and the regional center: " Centre de l' Enseignement et de l' Apprentissage Maritime " (CREAM) was set up.

To meet the demand for training foreign-going officers and senior engineer officers, the " Ecole Superieure de Navigation " was set up within CREAM in 1974.

With the development of trading by the emergent fleets of the African countries, existing training facilities were inadequate for the increasing need for qualified staff. The Government of Cote d' Ivoire issued Act N. 75-941 of 26th December, 1975, establishing the regionally-oriented Academy of Maritime Science and Technology in Abijan, Cote d' Ivoire.

The International Maritime Organization (IMO) and the United Nations Conference on Trade and Commerce on Trade and Development (UNCTAD) carried out the project at the request of the United Nations Development Program (UNDP). The Academy opened on 5th October, 1987.

The aim of the Academy is to train nationals as deck and engineer officers, radio officers, port officials and maritime administrators to meet the needs of the Ivoirian Merchant Fleet.

Shipping is an international activity which is under constant pressure to develop new types of ships to meet changing trade patterns and to update existing designs so that they can take advantage of advanced technology in

communication systems, navigation, machinery systems, etc. All these parameters increase the demand for skilled marine engineers in order to achieve safety, reliability and economy, which are key words in the running of any ship and any engine room today. It is against this background that training must be developed. Therefore the updating of an educational programme should consist of removing topics of decreasing importance as well as adding topics of increasing importance. Also the introduction of short courses related to specific needs in shipping can be programmed over special periods to avoid overloading the student if spread over a whole academic year. The special short courses would be very appropriate for those marine officers with long sea going experience but who are not familiar with the newly introduced technology. A new approach for the training of future marine engineers should meet the needs of shipping companies to stay competitive internationally. In particular, the engineer should learn in a modern and fast, as well as efficient way, to master the following operational skills:

- ship automation
- control engineering
- trouble-shooting diagnostics
- power plant optimization
- fuel economy, energy saving and maintenance planning to lower operational costs.

1.2 - Present Facilities and Practical training

"Training is one of those subjects that is never really understood. Some companies are quite proud of their policies and quite rightly so, whereas others consider it a necessary evil that costs them too much. There is also the human side, where a period undergoing instruction or attending a course is almost as good as holiday."(1)

"Training is imparting so much knowledge to a student that he is well equipped for the task of which he has to fulfill and moreover has such basic knowledge, that he can follow the development in maritime industry."(2)

1.2.1 General Education System

The education system of Cote d'Ivoire comprises a set of common educational institutions which are connected with one another in respect to their function and content. Primary education is common, free and compulsory. It is the lowest level, commencing at the age of six and consisting of six years of schooling.

(1) Training, Shipping World & Shipbuilding, p.402, Novembre 1989.

(2) Captain P. van Driest, Principal Hoger Zeeraartschool Amsterdam, Seminar on the marine education and training in Europe and new IMCO requirements.

Secondary education covers seven years, of which four are common and three years may be spent in one of the following branches: science, mathematics, math-technical, literature. On completion of their secondary education, students take a regional examination and successful students obtain a baccalaureat in their respective branches.

The baccalaureat provides the possibility to pursue higher education which includes universities, technological institutes and other higher specialized establishments. Periods of study are generally between two and six years, depending on the field of study and the nature of specialization.

1.2.2 Marine Officers

Training System

Maritime study for merchant marine officers is provided without cost to the trainees. Training schemes are entirely financed by the Government, and tuition, board and lodging are provided for students, who are also given a monthly allowance. The training courses include theoretical instruction related to the shipboard skills required by officers, general educational subjects and practical exercises and lessons.

Maritime studies for marine officers are offered at the "E.S.N" (Ecole Supérieure de Navigation) and the "C.E.A.M" (College d'Apprentissage Maritime), schools which are part of the Academy.

TRAINING SCHEME OF CAPTAIN AND ENGINE OFFICERS:1st grade

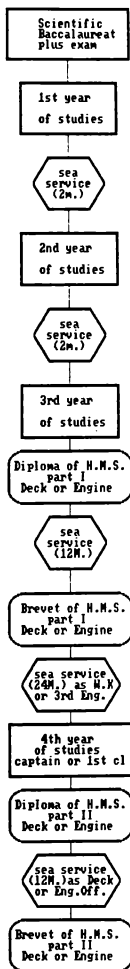

"E.S.N" School

E.S.N. is for the training of Captains and Engineer Officers (see Figure 2). The duration of training is six years. Four years are devoted to theoretical and practical studies at the Academy and two years to sea training on board merchant ships as apprentice officers. This cycle is the upper level and there are two ways to enter it:

- A - to have a baccalaureat (scientific, mathematics, technical or mathematics-technical).
 - the student must be less than 25 years old and pass medical and physical fitness examinations.
 - to pass an entrance examination which is given each year in the following subjects: Mathematics, Physics. English and Engineering Drawing are optional subjects.
- B - to have attended the "C.E.A.M" school and be admitted to enter the "E.S.N" school after examination.

The Diploma of Lieutenant, Deck or Engine Second Grade (apprentice) is awarded after a common examination at the end of the third year at the Academy. The Diploma of Apprentice Officer, Deck or Engine (Diploma of Lieutenant 1st Grade) is awarded after an examination at the end of the fourth year at the Academy. The Brevet of Officer (Brevet of Lieutenant Officer, 1st Grade) is awarded after 24 months at sea. It permits the holder to be an officer in charge of an engineering watch, in accordance with rules II/4 and III/4 of STCW 1978. The Diploma of Captain or Engineer Officer 1st Grade, is awarded after an examination at the end of the fourth year at the "E.N.S".

It allows the holder, after a certain time at sea as an officer in charge of a navigational watch, to become Chief Mate (Rules II/2) or a Second Engineer to become a Chief Engineer (Rules III/2).

The brevet of Master or Engineer Officer 1st Grade allows the holder having at least 60 months' sea service to carry out the function of Master or Chief Engineer on board ships of any tonnage and power (rules II/2 and III/2 of STCW 1978). It should be noted that the certificates of competency awarded to officers are of two types: firstly, the "Diploma", awarded for theoretical and practical training indicating the level of knowledge acquired during the studies at the "E.S.N."; secondly, the Certificate attesting that trainees have acquired experience on board merchant ships. This will assure the competent authorities that they possess the necessary qualifications and experience to exercise their functions on board ships.

The Normal Cycle

The normal cycle may be called training level two. It is for the training of Captain and Engineer Officers, Second Grade. The duration of training is 8 years, of which 4 years of theoretical and practical courses are undertaken at "E.S.N." and 48 months is at sea on board merchant ships as apprentice officers. For entrance into the 1st year course the student must satisfy the entrance conditions for the "E.S.N.", except that there is no entrance examination. The training at the normal level is in accordance with regulations II/4, III/4 and III/2 of STCW 1978. The Captain and Engineer Officers Third Grade of the "C.E.A.M." school can be admitted to the second year course of the normal cycle after an entrance

TRAINING OF RADIO OFFICERS



TRAINING SCHEME OF OFFICERS AT C.E.A.M.

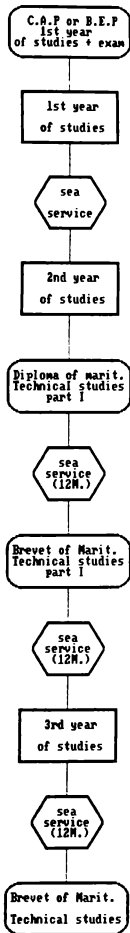

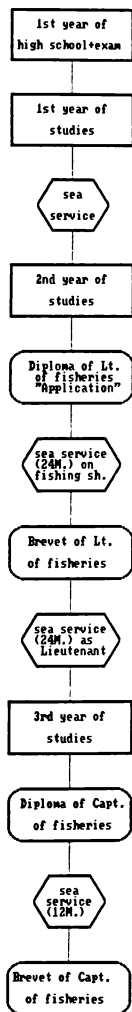

examination.

The C.E.A.M. School

The school of C.E.A.M. is for the training of marine personnel for fishing ships. In addition, this school's objective is to help students to become Captain and Engineer Officers, Third Grade. To enter this school, applicants must have the level of the 1st year of secondary school and take an examination. After a two year course at the school, the students take an examination and the successful students obtain the Diploma of "Patron de Peche", Captain or Engineer Officer, Third Grade. See Figure 4. Within 60 months of sea service the deck officer obtains the Brevet of "Patron de Peche" or Engineer Officer, Third Grade, after a total sea service of 48 months.

During the training at the Academy, special attention is paid to the instruction of students through courses and practical exercises in fire fighting, first aid and personal survival. The students are always called upon to keep the principle of safety in their minds as a priority. During the fourth year of the course at the Academy, students have to prepare a thesis on a maritime subject which is taken into consideration during the academic year. The academy receives students from the participating countries in the region, i.e.: Togo, Benin, Niger, Senegal, Congo, Cameron, Zaire, Gabon, etc.

The training of marine engineer officers is carried out at the Maritime Academy. It is the only establishment for the training of marine officers for the merchant marine. It was established in 1987, regrouping the old schools for the merchant marine. It is built on its present site on an area of 30 hectares in the city of Abidjan, the biggest city and port of Cote d'Ivoire.

The principal buildings of the Academy include: academic laboratories and workshops, academic buildings, offices for the faculty and administrative staff, large dormitories with a capacity of 268 beds, a mess hall and galley, and sport facilities. It serves as a boarding school and has a capacity of 165 students (year 1987).

Practical Training Aids for Marine Engineers

Training aids are any physical devices or tools used by the instructor as an added means of communication to facilitate the learning of the trainees. They are used in conjunction with instruction when explaining practical exercises in certain skills. Training aids are an aid to instruction, learning and direct experience, but not a substitute. Spoken or written words are the expression of thought and we use our senses of imagination to form a mental picture of the notion that the words seem to impact. Training aids assist in the process of communication by adding realism and substance to ideas, descriptions and explanations given in words during

courses. This is done through sight, the means by which a great part of all the things we learn come to us. Training aids put sight to us in learning, and they also give the trainee the opportunity to perform practical operations with his own hands. The result is an easier understanding and fuller retention of the subject matter by the trainee, a saving in teaching time, greater interest and morale of the trainee and faster development of practical skills. For these reasons, nobody concerned with the training of seafarers and marine engineers can really afford to neglect to employ or to use appropriate maritime aids to the fullest extent possible.

The practical training in professional courses for marine engineers at the Maritime Academy and at sea forms a very important and an integral part of the training aids: (a) laboratories and workshops and (b) training vessels.

(a) Laboratories and Workshops

Laboratories are used to implement and expand on the classroom instruction and to develop the categories and grades of marine engineers. Laboratory work is one of the most important phases of training for practical marine engineers, who must have an intimate knowledge of how to operate, test, maintain and repair a wide variety of machinery and equipment. The Academy has at the disposal of the students the following laboratories for marine engineers: electronics, electro-technology, electricity, automation, refrigeration plant, diesel engine, water, oil and fuel analysis, etc. The workshops comprise welding, fitting, forging and operations. The instruction in the workshops as a training aid is intended to qualify trainees to perform emergency repairs or basic shipboard

maintenance. Generally, the training in workshops is carried out during the first two years at the Academy.

(b) Training Vessels

The use of training vessels offers certain advantages in the practical instruction of marine engineers. Ship construction details, the various machinery and equipment fitted on board, piping, electrical and other systems, and layout are more readily studied and understood on board ship. Trainees can also be instructed in such tasks as machinery operation, maintenance and repair. The Academy has at its disposal two training ships: "Golf de Guinee", whose gross register tonnage is 228 tons, and whose machinery develops 800 horse-power; and "Alidate" of nearly the same characteristics as the "Golf de Guinee" and the first ship belonging to the Academy and the old school since 1975.

Each of them can embark 30 to 40 students for one day trips. One part of the sea training is carried out on board trading ships. This is carried out through the collaboration of the Ministry of Defense (marine).

Figure 6: Evolution of the Number of Students at the Academy

<u>Year</u>	<u>Number of students</u>	<u>Number of foreign students</u>
1987-1988	169	45
1988-1989	120	--
1989-1990	95	--

1.3 - The International Convention on Standards of Training, Certification and Watchkeeping for Seafarers, 1978 (STCW 1978)

Maritime training and examination/certification of seafarers are two vital and inseparable links in a chain which determines the standards of safety and efficiency of the operation of ships. It should be kept in mind that proper maritime training is the fundamental requirement and most important element in ensuring the safe and efficient operation of ships.

The convention, which has great relevance to seafarers, is the International Convention on Standards of Training, Certification and Watchkeeping for Seafarers, 1978, of the international Maritime Organization. This Convention is the first attempt to establish global minimum professional standards for seafarers. The whole aim of the STCW 1978 Convention is to ensure that merchant ships operate safely and efficiently with maximum protection of the environment against pollution.

The STCW 1978 Convention was adopted by the member states of the International Maritime Organization (IMO) at an International conference held in London in 1978. The Convention prescribed minimum standards which contracting parties are obliged to meet or exceed. The Convention would come into force one year from the date on which 25 countries, the combined merchant fleets of which

constitute not less than fifty percent of the world's merchant shipping (of vessels of 100 gross register tons or more) have acceded to it. This target was reached on 27th April 1983 and the STCW 1978 Convention entered into force on 28th April 1984. The Convention provides for the first time, on an international scale, minimum standards for seafarers in terms of the levels of theoretical and practical knowledge linked to professional experience and understanding required for the certification of professional competence of seafarers. The effect of the Convention's entry into force will therefore be to raise standards in the world. One especially important feature of the convention is that it will apply to ships of non-party states when visiting ports of states which are parties to the Convention.

The technical provisions of the Convention are contained in an annex which is divided into six chapters dealing with the following subjects:

- (i) General Provisions
- (ii) Deck Department
- (iii) Engine Department
- (iv) Radio Department
- (v) Special Requirements for Tankers
- (vi) Proficiency in Survival

(i) General Provisions

This chapter deals with control procedures, certification and power of the port States.

(ii) Deck Department

This chapter establishes the basic principles to be

observed in keeping a navigational watch, watch arrangements, fitness for duties and responsibilities, the duties of the lookout, navigation with pilot on board and protection of the marine environment. It covers Masters and Chief Mates of ships of 200 gross tons to 1600 gross tons and of ships of 1600 gross tons and above, Masters and Officers in charge of navigational watches on ships below 200 gross tons and ratings. The structure relating to deck officer certification is illustrated in Figure 7.

(iii) Engine Department

This chapter sets up the basic principles to be observed in engineering watches, general operation, watch requirements, fitness for duties, and protection of the environment. The requirements for deck officers vary according to the tonnage of the ships. However, for engineer officers, the determining factor is the propulsion power of the engine. The regulations cover mandatory minimum requirements for certification of Chief Engineer and Second Engineer Officers of ships powered by main propulsion machinery of 3000 kW or more and ships of 750 kW to 3000 kW. There are also requirements for engineer officers in periodically unmanned engine rooms. The mandatory requirements for the Engine Department are contained in six regulations and appendices to them.

Regulation III/1 Basic principles to be observed in keeping an engineering watch.

Regulation III/2 Mandatory minimum requirements for Certification of Chief and Second Engineer Officers of ships powered by main propulsion machinery of 3000 kW or more.

Regulation III/3 Mandatory minimum requirements for

DECK OFFICER TRAINING AND CERTIFICATION,
AS REQUIRED BY IMO STCW 1978 CONVENTION

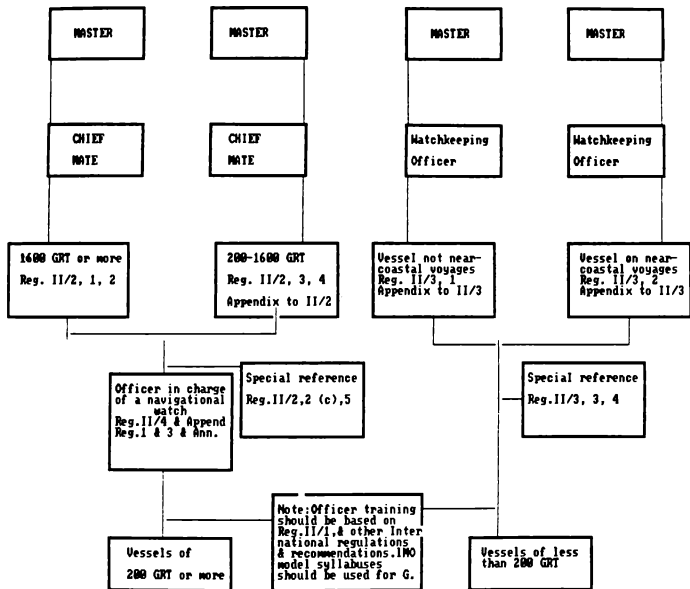

- Regulation III/3 Mandatory minimum requirements for Certification of Chief and Second Engineer Officers of ships powered by main propulsion machinery between 750 kW and 3000 kW.
- Regulation III/4 Mandatory minimum requirements for Certification of Engineer Officers in charge of a watch in a traditionally manned engine room or designated duty Engineer Officers in a periodically unmanned engine room where the propulsion power is 750 kW or more.
- Regulation III/5 Mandatory minimum requirements to ensure the continued proficiency and updating of knowledge for Engineer Officers.
- Regulation III/6 Mandatory minimum requirements for ratings forming part of an engine room watch.

The structure relating to the engineer officer's certification is illustrated in Figure 8. A detailed diagramme for marine engineer officers is shown in Figure 9.

(iv) Radio Department

This chapter is concerned with the radio department. The mandatory provisions relating to this department appear in the Radio Regulations and the SOLAS Convention.

(v) Special Requirements for Tankers

The chapter illustrates the importance of this type of ship. Attention is paid to both safety and pollution aspects.

MARINE ENGINEER OFFICER TRAINING AND CERTIFICATION AS REQUIRED BY IMO STCW 1978 CONVENTION

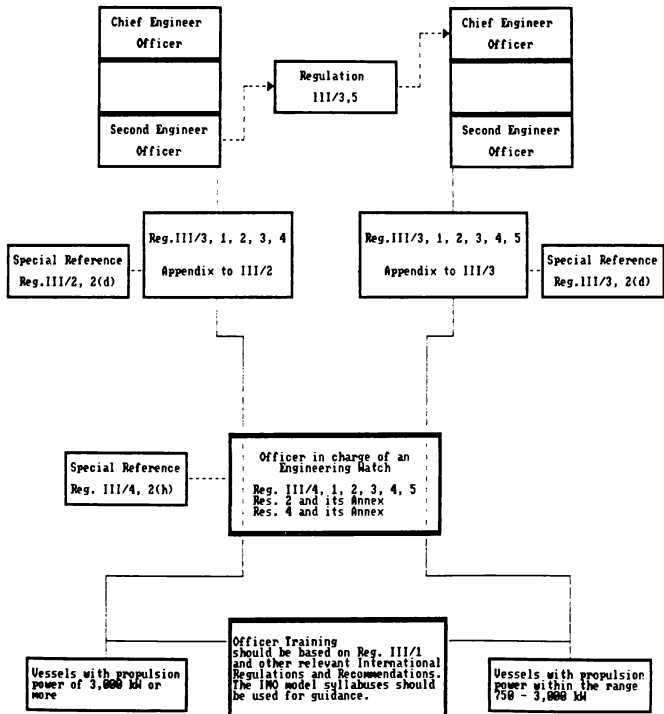

**MARINE ENGINEER OFFICER
TRAINING AND CERTIFICATION
IN TERMS OF
THE IMO STCW 1978 CONVENTION**

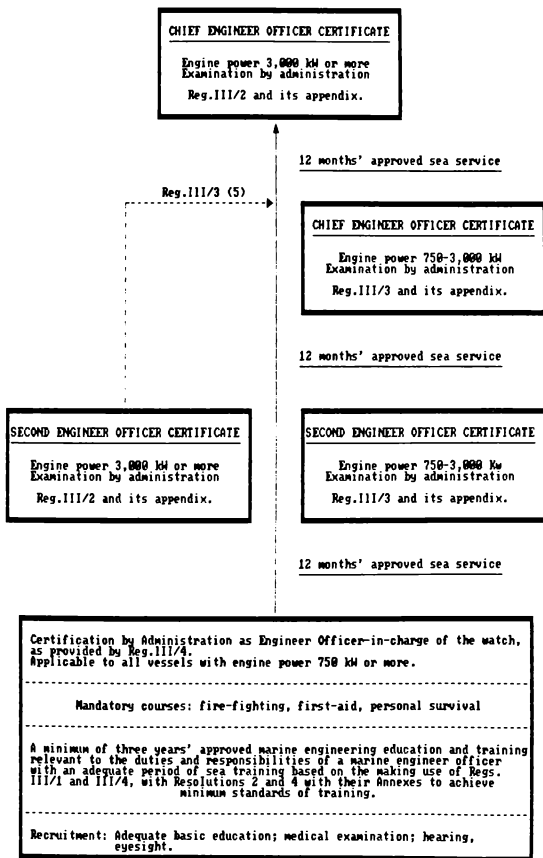

FIGURE 3

This chapter establishes requirements governing the issuance of certificates and proficiency in Survival Crafts. There are also a number of Resolutions adopted by IMO since 1978 relating to training of seafarers.

IMO's Assistance in Cote d' Ivoire

The Cote d'Ivoire Ministry of Defence gives the highest priority to the training of national seafarers. The Academy, which is under the supervision of this Ministry, works in close collaboration with the IMO. In order that the Academy fulfills its objectives at the professional level and in order to improve the standards of education and training of seafarers to meet the requirements of STCW 1978, the Cote d' Ivoire Government requested IMO to provide project assistance. The objectives of the project are:

- to reinforce maritime education
- to train the training staff with the assistance of a number of expatriate personnel, to develop a mid-term strategy for Maritime Training. The foregoing was envisaged to contribute in the application of the STCW Convention. A program drawn up by IMO, the United Nations Development Programme (UNDP) and the Government was approved in 1978. It called for an adviser, experts, consultants, equipment and also a training component.

Figure 10: The various subjects which are included in the curricula are illustrated in Figure 10.

First Year

Theoretical Courses	Hours/Week
Mathematics	4.5
Electrical Engineering	1.5
Thermodynamics	4.0
English	2.0
Workshop Technology	3.0
Engineering Drawing	3.0
Celestial Navigation	1.5
Navigation	4.0
Laws	1.0
Rules of the Road, Port Signals	1.0

Practical

Electrical Engineering	1.0
Fuel Technology, Lubricants, Combustibles	0.5
Workshop Machines	1.5
Signals	0.5
Practical Navigation	0.5

Seamanship

Knots	1.0
Boat Handling	1.0

Second Year

Theoretical Courses	Hours/Week
Mechanics and Strength of Materials	2.5
Electrical Engineering	2.0
Electronics	1.5
Fluid Mechanics	4.0
English	2.0
Ship Construction	3/4
Plan Drawing	3.0
Radio Electronics	1.5
Navigation, Charts	4.0
Maritime Legislation	3/4
Practicals	
Machinery	1.5
Electrical Engineering	1.5
Electronics	0.5
Navigation	1.0
Physical Education and Sports: One afternoon a week.	

Third Year

Theoretical Courses

Electrical Engineering	1.5
Electronics	1.5
Machinery	5.0
English	2.5
Automation	2.0
Hygiene	0.5
Radio Electronics	1.5
Theory of Navigation	3/4
Navigation, Charts	2.5
Maneuvering	3/4
Commercial Law	1.0
Ship's Operation	0.5
Meteorology	1.0
Rules of the Road, Buoyancy, Port Signal	0.5

Practicals

Machinery	1.0
Steam Turbine	3.0
Electrical Engineering	3.0
Electronics	1.0
Automation	1.0
Navigation	1.0

Physical Education and Sports: One afternoon a week

Fourth Year

Theoretical Courses	Hours/Week
Electrical Engineering	1.5
Machinery	1.5
English	1.5
Reports	1.5
Safety, Accident damage	3/4
Automation	2.5
Maritime Commerce	1.0
Hygiene	0.5
Electronics	2.5
Theory of Navigation	1.5
Navigation	1.5
Practice of Formalities	1.0
Ship Handling	3/4
Ship Operation	1.0
Practical Study of Boarding Regulations	1.5
Legislation and Accounting	1.5

Practicals

Electrical Engineering	1.5
Automation	1.5
Electronics	3.0

Physical Education and Sports: One afternoon a week.

**Diesel Engine Simulator Training Course For
Marine Engineers At ABIDJAN Academy**

"You do things right because you have experience: you have experience because you do things wrong."

(Chinese Proverb)

2.1 - Introduction

In 1986 an engine room simulator was put into operation at the Maritime Academy in ABIDJAN. The main reason for this was to obtain a facility that could be used in the training of ship engineers in the safe and economic operation of maritime transportation.

The engine room simulator is described in this paper. To ensure clear communication, the term simulator must be defined.

A simulator is a machine that attempts to reproduce or represent the exact or nearly exact phenomena likely to occur in the real world. The "real world" may need to be represented for a number of purposes.

Engineering simulators represent and manipulate real-world phenomena so that conclusions may be reached about man-made products inter alia ships. Simulators are good for both trainee and expert practice.

There are a variety of simulators that have been designed

for specific training purposes, including skills development, decision making and problem solving. Before examining these specific efforts, here are the reasons for simulation.

During the last decade, simulators for training have become an accepted teaching aid in nautical circles. The most widely used types of marine simulators nowadays are the ship's bridge and engine room simulators for training deck and engineer officers. The gradually improved marine training simulators have become true-to-life. The invention, design and creation of suitable forms and types of these simulators occupy a considerable amount of ingenuity of professional engineers, technologists and scientists throughout the world. More recently computers have enabled machine responses to be modelled in the most sophisticated manner.

Today the simulator honeymoon is over. Ship simulators for training are no longer a novelty; they have become essential aids in maritime training and like any other training aid, they should be used to maximum advantage. The use of ship's simulators for training can be summarized as having two objectives: safe and efficient ship operation. What does safe and efficient ship operation mean? It means a further reduction of a ship's complement, an integration of functions on board, a more reliable automatic control and monitoring system on board, and more efficient sailing with respect to fuel economy. It can also mean a stronger demand for safety at sea.

In response to the rapid development of more complex and sophisticated marine power plants, many maritime training institutions have recently built and installed engine room

simulators for training marine engineers. A question arises as to what shall be called an engine room simulator. A common, general definition of an engine room simulator is a complete engine room system where all the machinery has been reproduced through the application of a computer programme to present specific engine room components as they would be onboard modern ships. The system is designed in such a way that all operational actions taken by the trainee produce fair operational functions of a typical main propulsion plant. The simulated engine room system covers both the main propulsion plant and the auxiliary components throughout the engine room. The Engine room simulators are divided into three versions:

- i steam plant simulators,
- ii medium-speed diesel plant simulators,
- iii slow-speed diesel plant simulators.

This chapter deals with an engine room simulator with a slow speed diesel plant that is called a "diesel engine room simulator".

2.2 - Purpose

The purpose of using a diesel engine room simulator is to provide an educational and training aid that will give a fairly realistic reproduction of the behaviour of a typical propulsion diesel plant and auxiliary equipment as found on board modern ships. This facility will permit marine engineers to gain significant training in the skills of efficiently operating and troubleshooting a modern automated propulsion system. This aid can be used also in the training of ship engineers in the safe and economic operation of diesel engine machinery. And it is

useful for training junior engineers in basic engine room operation, training senior engineers in emergency operation and trouble-shooting and training senior and chief engineers in optimal plant operations, fuel economy and energy saving.

Simulators and associated training aids, either in the form of equipment or documentation, are able to generate an environment where a group of trainees may be trained in both operational and corrective procedures on equipment related to realistic ship systems, where the maximum penalty for incorrect actions is limited to the embarrassment of the trainee. Knowing he has "made a mistake" is usually sufficient to ensure a better understanding of the correct procedures should the fault occur again.

Summarizing, it can be said that simulators provide 7 main advantages over other forms of training in the area of:

- i lowered training costs
- ii time saving in achieving operational experience
- iii more effective training
- iv repeatability conditions
- v availability
- vi safer training
- vii evaluation

- i lowered training costs

A training simulator provides the means by which different training situations, operational scenarios, fault or emergency conditions, may be programmed for training purposes, without involving the costs associated with putting a ship to sea, and without involving any

operational units or personnel.

ii time saving in achieving operational experience

It takes years for a marine engineer to experience a sufficiently great number of various malfunctions and failures in the machinery installed to really become an experienced and safe operator. The engine room "diesel plant" simulator overcomes this by providing considerably fewer practice hours for approximately the same experience. The dynamic real-time simulator may compress years of experience into a few weeks. Thus the simulator saves time.

iii repeatability conditions

Due to the ability of a training simulator to repeat exercises or situations without error, student performance may be assessed objectively to ascertain errors in technique. Also, successive students can be subjected to the same situations.

iv availability

Training programmes can be prepared for differing courses and different curriculum with the knowledge that, unlike a ship's operational equipment, the training simulator will be available in one location normally adjacent to lecturing facilities.

Training programmes can also be re-arranged to suit the trainees' requirements whilst the course is in progress and additional courses can be programmed in at short notice.

Whether the training is more effective can perhaps be questioned, mainly because factors such as attitude training and factual training are so important on board a vessel. On the other hand, skill training is almost certainly more effective on the diesel engine room simulator than on board ship, because the conditions are completely under control. The trainee certainly will both remember and believe in his theoretical knowledge better when he tests and proves it during training on the simulator. The training on the diesel engine room simulator is further more effective since it develops the students' ability and methods of decision-making.

Some examples of exercises on the simulator which are effective training possibilities are as follows:

i) It is possible to analyse the combustion and injection information of each cylinder on the indicator diagram. The diagram is printed by a six-channel recorder. The recent use of the Diesel Engine Tuning System (DETS) for the control of the combustion and injection makes the exercise and analysis of such a system on the simulator more effective. Figure 11 illustrates an example of the possibility to analyse the combustion and injection pressure of one cylinder.

ii) Wear of the piston rings and bearings on a marine diesel engine is very slow and is only apparent over a long period. The recent use of the Piston Condition Monitoring System (PCMS) provides the opportunity to see the wear condition on different positions of the piston

INDICATOR DIAGRAM

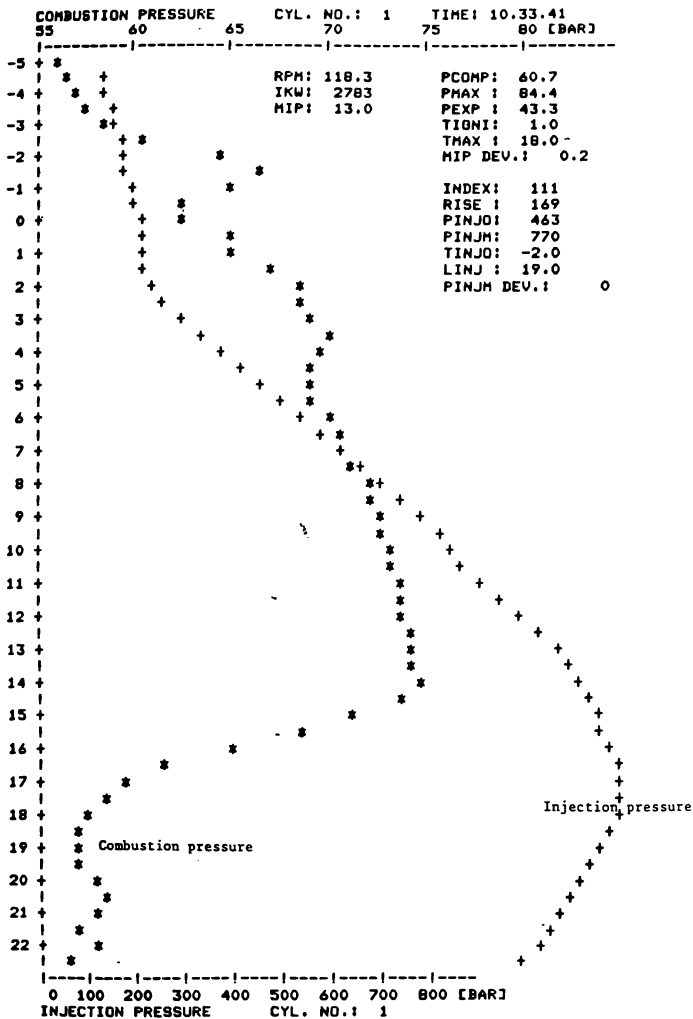

FIGURE 11

rings. On the simulator serious wear can be demonstrated and analysed. As an example, Figure 12a shows the normal piston ring condition. Figure 12b shows piston ring wear condition after a certain time; Figure 12c demonstrates the piston wear condition after a certain period of time.

VI Safer Training

Finally, and perhaps most important of all, the diesel engine simulator is the safest method of training. Training to enable personnel to meet dangerous situations is best carried out under safe conditions where there is no risk of damage. For instance, the training for emergency stoppage of the main propulsion plant, emergency running, scavenging air box fire, piston seizure, crankcase explosion, engine room fire, lost propeller, heavy hull fouling, electric power supply blackout, and so on, can all be practised safely. Additionally, several other instances which may occur in the engine room machinery and remote control room, can be exercised on the simulator whereas they cannot safely be carried out on board a vessel without jeopardizing the interest of the shipowner or the safety of the ship, her crew and in some cases also the environment. Examples of some exercise situations carried out under safe conditions are:

a) Analysing the effect on the main engine when the propeller is lost can be drilled in safe condition. The propeller is lost, the main engine overspeeds. The regulator adjusts the fuel lever and the engine speed returns to normal and the ship speed decreases gradually due to the ship's inertia (Figure 13).

b) Analysing the effects of various parameters on the

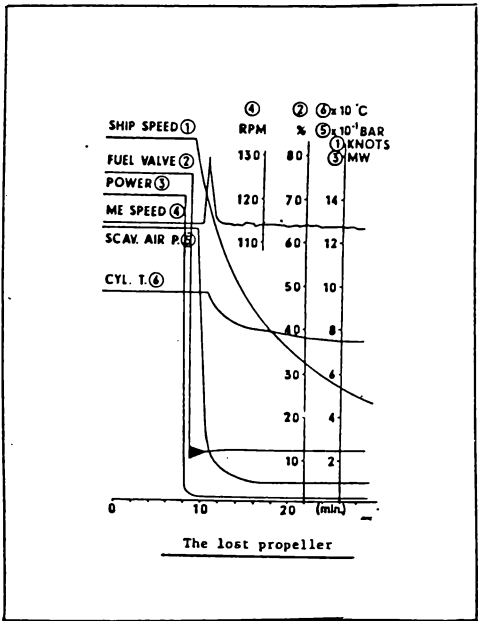

FIGURE 13

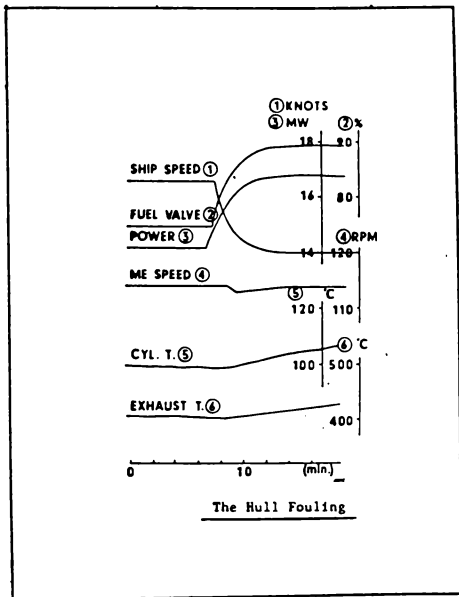

FIGURE 14

characteristics of the engine when the hull of the vessel is fouled. These parameters are:

Parameter name		Normal	Heavily fouled
Main engine speed	RPM	114	114
Cylinder temperature	Dgr C	99.7	108
Exhaust temperature	Dgr C	394	426
Fuel lever		0.752	0.901
Main engine shaft power	MW	13.320	15.967
Fuel oil flow	T/H	2.723	3.262
Ship speed	knots	16.645	14.144
Fuel oil inlet pressure	Bar	4.982	4.207
Mean indicated pressure	Bar	10.6	12.6
Main engine efficiency		0.8955	0.9027

Figure 14 illustrates the dynamic characteristics of the main engine. The main engine speed is normally controlled by the regulator. But the fuel lever is shifted further, the ship speed still decreases, the exhaust temperature rises, the temperature of cylinder liner increases. The main engine is therefore develops more power. The main indicated pressure then increases.

c) The simulator can also simulate the functioning of the variable pitch propeller according to the variation of pitch, main engine speed, fuel lever, power, ship speed, propeller torque and thrust. All these parameters change correspondingly as illustrated in the table on Figure 15a. The characteristics of the propeller pitch can be plotted as shown in Figure 15b.

FIGURE 15A
The characteristics of varying pitch propeller

Pitch	Engine Speed RPM	Shaft Power MW	Torque	Thrust	Ship Speed KNOTS	Fuel Valve opening
100Z	110	16.595	1.137	0.992	18.0	3.36
90Z	114	16.246	1.079	1.003	17.3	3.31
80Z	114	13.354	0.887	0.885	16.8	2.70
70Z	114	9.975	0.664	0.734	16.0	2.17
60Z	111	6.506	0.444	0.553	14.6	1.55
50Z	99	7.860	0.221	0.331	11.5	0.889
40Z	86.9	0.900	0.080	0.156	8.4	0.428
30Z	75.1	0.126	0.014	0.040	5.7	0.206
20Z	69.7	-0.003	0	-0.034	4.0	0.188
0Z	50.8	0.398	0.059	-0.047	2.0	0.211
-20Z	70.1	0.272	0.028	-0.123	-1.2	0.275
-40Z	89.2	1.995	0.169	-0.313	-6.5	0.782
-60Z	112	9.975	0.673	-0.834	-11.1	2.21
-80Z	113	17.031	1.137	-1.132	-13.0	3.47
-100Z	97.3	14.759	1.149	-0.992	-12.3	3.0

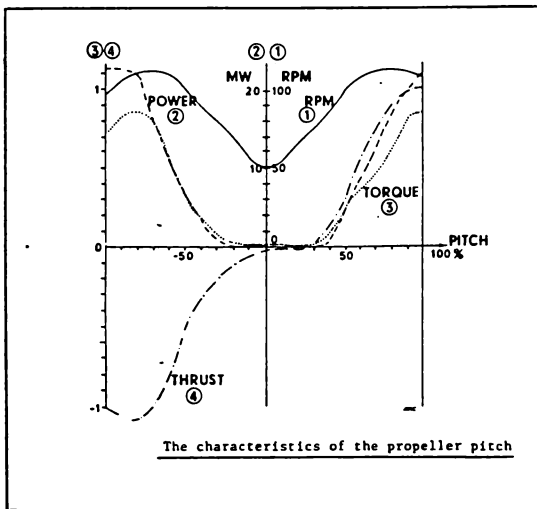

FIGURE 15B

VII evaluation

In addition to training, experienced personnel can use a simulator to formulate and test various emergency procedures or operational tactics.

2.3 Simulator process by computer techniques.

"Diesel Plant Simulators" for training, have been developed, built and installed in many institutions all over the world in the last two decades. All have in common what we call a mathematical simulation model programmed on a computer describing an engine room's characteristics.

Using the marine engine simulator during my field trips as a teaching aid, I have discovered many special merits of the simulator: the economy of simulator training, the possibility of repeated training of the students, improving their ability to analyse and remove faults, the shortening of the damage process, and the possibility of special studies.

The diesel engine room simulator in ABIDJAN ACADEMY is controlled by a computer system in which have been installed mathematical models of a marine power plant and in which adequate devices for adjustment and display have been set up to simulate various operating conditions of ship power plants.

Digital computers have replaced the analogue computers, thus, giving a new dimension to the development of the engine room simulation process by computer techniques. This has permitted the building up of good and efficient

models with a certain flexibility. The simulation models, which are interconnected in many different ways and can be adjusted to specific plant requirements, are of three different types:

- a) basic models
- b) system models
- c) plant models

a) basic models

A basic model may represent, for instance, a valve, a pump, a filter, an actuator, a sensor, a controller, a cooler, a heater, a tube, a tank, etc. Each basic model is set up as a mathematical function describing a law of physics, and has input variables, mathematical functions and output variables. The mathematical function contains also certain constant factors. The mathematical functions are computed at regular intervals, the output values varying with the variation of input (time-dependent), the simulation models therefore being dynamic.

b) system models

The system models consist of various numbers of basic models. An output variable from one basic model, e.g. a valve, is an input variable to another basic model, e.g. a pump; the output of the pump may be an input of a filter, and so on with various basic models concerned. All of these basic models are linked together to form a system model which represents a specific major part or function of the plant. The following samples are some of the

system models that can be constructed:

- fresh water system
- lubrication oil system for main engine
- sea water system
- fuel oil system
- fuel oil storage tank system
- electric power supply system
- compressed air system
- boiler combustion system
- piston cooling system
- ship propulsion system
- injection valve cooling system
- main engine bearing cooling system.

Figures 16 and 17 are models of a lubrication oil system and a fresh water system.

c) plant models

The plant model represents the total engine room configuration and it is built up by various system models. For example, a model drawing with a slow speed engine plant is illustrated in Figure 18. Following analysis of all engine room machinery and systems, they are represented by a mathematical model, and a programme is thus obtained for the computer to simulate the engine room operations. Dynamic models of all components are accurately depicted. The connection and integration of all component models form a complete engine room process which is controlled by the computer system. Mathematical models of the propulsion plant with associated auxiliary systems are loaded into the computer's memory through a floppy disc. The computer with simulation models is

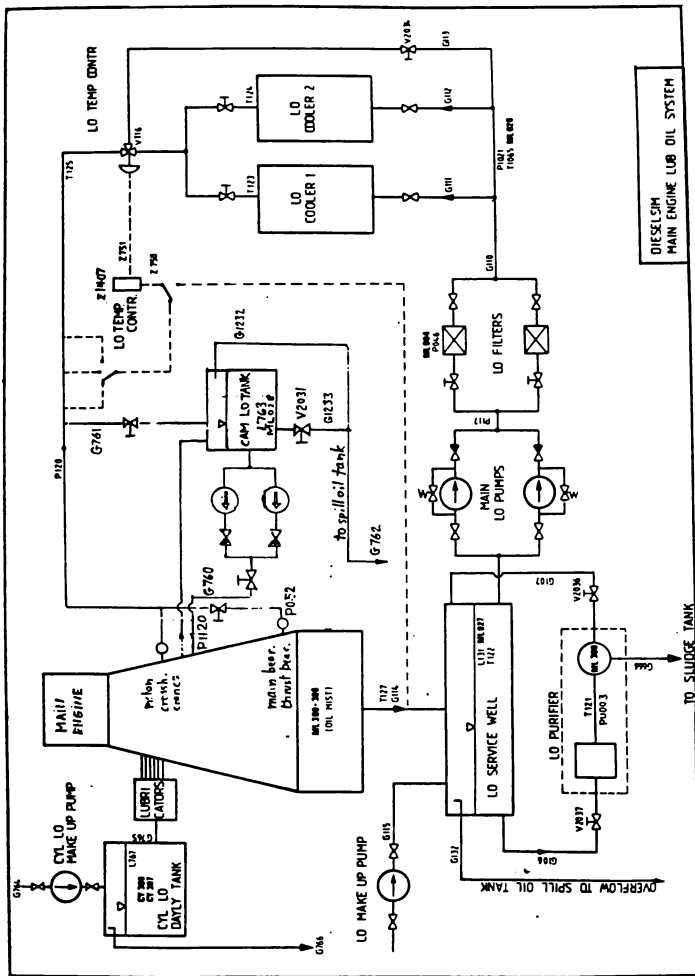

DIESELSIM
MAIN ENGINE LUB OIL SYSTEM

TO SLUDGE TANK

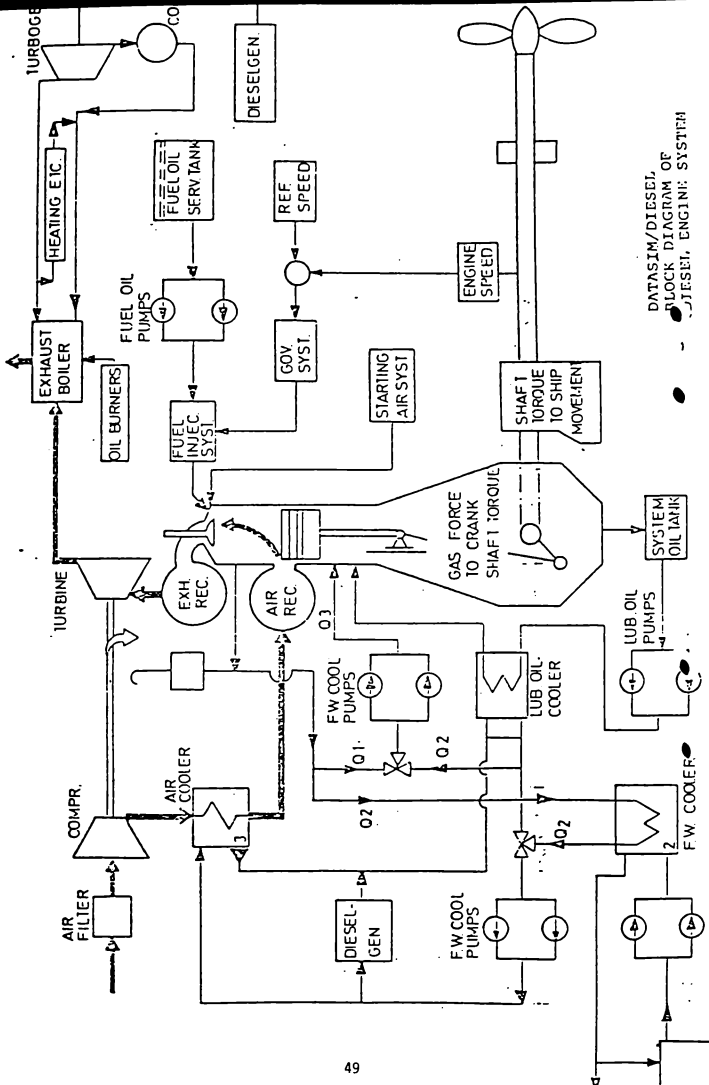

DATASIM/DIESEL,
BLOCK DIAGRAM OF
DIESEL, ENGINE SYSTEM

connected to the instructor's station and the room control equipment. The programmed diesel engine room model responds accurately to the input from the engine control room. The software of the computer consists of various programmes necessary to operate the whole engine room, presented through mathematical models. Flexibility is achieved by using a general purpose computer with memory directly accessible from the floppy disc. Extension or alteration of the simulating programmes may be done by just reading in a new floppy disc.

2.4 Description of the Engine Simulator:

The Engine Simulator consists of:

- the control room
- the "Bridge"/Instructor's room
- the engine room

Figure 19 gives a schematic simplified flow simulator layout.

2.4.1 The Control Room

The control room is a facsimile of an engine control room as usually found on board modern ships. The training is performed in an environment similar to the actual ship's control station environment. The engine control console consists of the following console sections:

- a) main engine maneuvering console section
- b) auxiliary boiler control section
- c) logger and alarm system console section
- d) generator switchboard and group starter panel

console section

e) super economical shaft generator.

Some of the items of equipment are briefly described.

a) Main Engine Maneuvring Console Section

The main engine maneuvering section includes:

a remote main engine maneuvering device, a sub engine telegraph, main engine control position changeover switches, a remote control switch for main engine starting air, automatic control switches for main engine scavenging, air pressure control, remote control switches for main engine fuel oil changeover, instruments for remote monitoring of main engine running conditions and a telephone set for communication with the wheelhouse.

The remote main engine maneuvering device consists of a speed setting lever (F.O. handle), a reversing lever (also serves as an engine telegraph response lever), a start push button and auxiliary controls such as emergency stop switch and emergency override switch.

b) Auxiliary Boiler Control Section

This console section has an automatic combustion controller and auxiliary controls for the boiler, a feed water controller, exhaust gas economizer, superheater steam valve changeover switches and soot blower switch, and truments and indicator lights for remote monitoring of the auxiliary boiler.

c) Logger and Alarm System Console Section

This console section is fitted with an automatic alarm system, a watch free system. The logger equipment prints out the data stored in the automatic alarm system on demand at any time.

d) Generator Switchboard and Group Starter Panel Console section

In actual ships, switchboards and group starter panels are not part of the engine room console, but separately installed independent units. In this simulator, they are included as part of the engine control console for training purposes.

e) Super Economical Shaft Generator (SSG)

The SSG is equipped with the simulator and a mimic panel for the SSG control is provided in the engine control console.

2.4.2 Instructor Room Console

The instructor room console has a wheel house maneuvering panel for remote control of the main engine, and also a start switch for start-stop control of the simulator, an initial start condition setting panel for simulation start conditioning, and an abnormal condition setting panel for simulation condition changing.

2.4.3 The Distributed Processing Computer System

The distributed processing computer system is the heart of the simulator and consists of a digital computer. Two computers are installed in a control processing unit panel, one computer in the engine control console, and the other computer in the instructor's console. These computers are interconnected by an optical fiber system for data transfer.

2.4.4 Sound Generator

A sound generator is installed in the central processing unit panel. It is electronically controlled and three speakers are used to reproduce specific sounds which represent the sounds generated by the main engine, turbo-generator, diesel generator and air compressors.

2.4.5 Printers

Four printers are used in the simulator:

--the engine Log Printer to print out the variable data such as pressures, temperatures, levels and speeds, etc..which are stored in the automatic alarm system at preset interval or on demand at any time.

--the Alarm Printer to automatically print out the alarm-state monitored variable data whenever the automatic alarm system detects an abnormal condition.

--the Hard Copy Printer, a color printer, copies the information as displayed on the cathode ray tube display of the automatic alarm system.

--the Event Printer to print out the training event data in the order of occurrence of events, such as starting and stopping of the main engine, generators, and auxiliary boiler and serious misoperations by the trainee during the training course.

2.4.6 A Central Processing Unit Panel

Has two computers and a sound generator with its own computer.

2.4.7 Power Source Panel

Electrical power for the simulator is supplied from a large storage battery which can supply D.C. power to the simulator for some duration.

2.4.8 The Engine Room Graphic Panel

On board modern ships, the engine room equipment is located all over the engine room. To stimulate this situation, different local engine room control panels are supplied.

For the Diesel Engine Plant, the local panel for each of the following engine room systems/components are provided:

Main Engine and Turbo Generator Group

This panel comprises:

- main Engine, including air coolers and turbochargers
- L.O. pumps

- crosshead L.O. pumps
- jacket C.F.W. pumps
- piston C.F.W. pumps
- fuel valve C.F.W. pumps
- main and auxiliary C.S.W. pumps
- F.O. booster pumps
- vacuum pumps
- condensate pumps
- and heat exchangers, tanks and piping systems
necessary for normal functioning of these pieces
of equipment.

Auxiliary Boiler Group

This panel comprises:

- auxiliary boiler
- exhaust gas economizer
- boiler fuel oil burning pumps
- waste oil burning pumps
- boiler feed water pumps
- boiler circulating pumps
- forced draft fans
- and heat exchangers, tanks and piping systems.

Generator Group

This panel comprises:

- diesel generators
- main and auxiliary air compressors, sea water
service pumps, and the heat exchangers, tanks
and piping systems.

Fuel Oil Group

This panel comprises:

- main and auxiliary fuel oil pumps
- heavy fuel oil purifier
- diesel fuel oil purifier
- heavy fuel oil tank
- diesel fuel oil tank and the piping systems for equipment inter-connection.

Bilge Treatment Group

This panel comprises:

- fire and general service pump
- fire pump and ballast pump
- bilge pump
- bilge oil separator pump
- sludge pump
- bilge oil separator and the tanks and piping systems.

Machinery Directly Operated on the Graphic Panel

The following machinery components are directly operated on the graphic panel :

- starting of the main engine (emergency)
- main engine turning gear
- main engine aux. blower
- starting of the diesel generators
- air compressors

- pumps
- D.F.O./H.F.O. blender and blended oil mixer
- purifiers
- bilge separator
- distilling plant.

The valves arranged on the graphic panel are as follows:

- ordinary valves, including drain traps
- safety valves
- motor and solenoid operated valves
- various regulating valves such as temperature, pressure and level regulating valves, not operable on the graphic panel but by supplying the control air.

The open-closed status of the valves on the graphic panel is stored as the valve status data in the computer system and actually affects the functioning of the other equipment in the simulation as they would do in a real ship.

In short, more components and systems may be added according to the engine room simulator required. Equipment for resetting trip and for simulating repair of malfunctioning components are also available on the local panels. The trainees are normally confined to the control room, but visit the engine room, for example, to check the state of controlled component, reset malfunctions and practice the normal operation of control valves.

Several pushbuttons of the main engine represent one type of fault. Additionally, the panel has provision for adjustment of the fuel rack position for each cylinder.

Loudspeakers are also available in the engine room in order to reproduce the engine sounds.

There are also other diesel engine room simulators using a more advanced simulation technology. In this type all panels and consoles may be replaced by a colour graphic processor and colour graphic screen housed in the student's and the teacher's terminals. The colour graphic screen displays system diagrams of the simulated diesel engine room. It is also the engine room panel. The student's terminal consists of a colour data video display, a keyboard and a printer for logging actions taken by the student and by the teacher, as well as for normal alarm printout. The student terminal is part of the alarm and the remote machinery operation system. The student is able to call a mimic diagram to the colour display for each of the simulated sub-systems. In the mimic diagrams the trainee is able to observe the conditions of the simulated systems. Several of the simulated machinery components displayed can be operated from the student's keyboard, for example opening and closing a valve in the fresh water system. The same keyboard is used to acknowledge the alarms coming up. From the student's keyboard, it is also possible to make simulated overhauls of malfunctions introduced from the teacher's keyboard.

2.5 IMO's Work on Marine Simulator

With the present advanced marine technology and sophistication of ship automation, it was clear that contacts between researchers, designers, manufacturers and users of marine simulators are of great importance. So in September 1978 the International Maritime Organization

established the International Marine Simulators Forum (IMSF). The aim of the IMSF is:

- to provide an effective medium for the interchange of views and experience in simulator development;

- to improve the state of art of simulators;

- to study the manufacture and utilization of marine simulators for training and examination of seamen and to improve their application for training and research;

- to advance the development and to promote the use of marine simulators in order to improve maritime safety and productivity worldwide.

The work of the IMSF has successfully been supported by the International Conferences on marine simulation held in 1978 at Southampton, England, in 1981 in New York, U.S.A, and in 1984 in Rotterdam, The Netherlands.

Training Programmes For Marine Engineers At Other Maritime Institutions.

Introduction.

Technology in shipping has undergone a revolution in the past decades, causing the need for establishing new models of training in different countries.

Many developing countries have been compelled to improve the level of maritime schools and establish universities or maritime academies. This has been done also in some developed countries.

New models of navigation have been introduced which enable the ship's personnel to give more attention to controlling procedure and decision-making, which increases safety standards by reducing human error. This trend has resulted in the introduction of a new approach of training methods for personnel in many training institutions with the aim of meeting the new safety requirements.

On the basis of what has been said, there is a need for changing in the policy of training models in different countries including developed countries. Ship officers must be trained to be able to meet all demands relating to developments that can arise in international shipping.

In others words, ship officers must be able to perform different tasks, namely:

1. To apply all international regulations on board ships.
2. To take a right decision in dangerous situations at sea.
3. To be capable of operating the ship with the highest cost effectiveness.
4. To evaluate the ship's performance in case of a dangerous situation and make her safe.
5. To use effectively modern, technical systems for the optimisation of the ship's operation processes
6. And to use the internal and external information flow to operate the ship safely and effectively.

3.1 IMO'S ROLE AND MODELS OF TRAINING.

The effectiveness of training processes are based on four fundamental elements, namely:

1. level of candidates and syllabus.
2. level of teaching staff.
3. methods of training.
4. teaching aids and equipment used.

The relationship between the model of training, its effective manning system and the kind of ship's and operational system is shown in Figure 20.

There is a significant IMO role in raising the standards of training of seafarers in the world by establishing various maritime Conventions.

It has been proved that the principal key to the improvement of maritime and environmental safety lies in enhancing the education and training of all personnel involved in international shipping. Today IMO has established 35 major Conventions of which 27 are already in force. The most important is the International Convention on Standards of Training accepted by 73% of World merchant shipping tonnage.

The E.E. countries have already accepted and ratified the STCW 78 Convention and its results have been implemented by various institutions in their syllabuses.

The effective enforcement of convention requirements requires the active involvement of well trained and

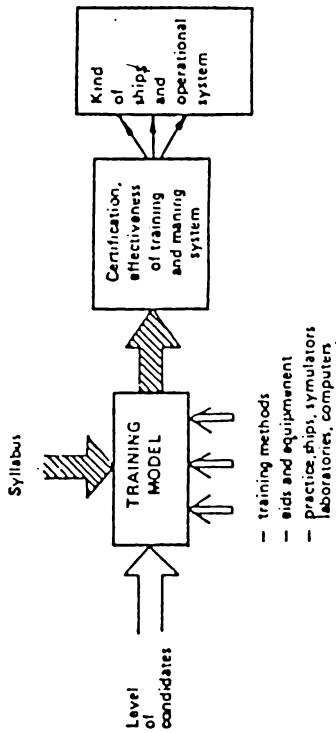

FIGURE 20 - THE TRAINING MODEL SCHEME

experienced ship personnel. They can be regarded as the fundamental models of training cadets and sea-going officers in the world training institutions.

The first model is based on a high level of theory where practical aspects are supported by training vessels and simulators are also used.

In the second model, the theoretical level is not very high, the period of sea training on an operational basis is maintained, and simulators and computers are used.

The third model is based on minimum requirements of the STCW-78 Convention. A short period on board ship and some time devoted to simulator training is maintained. Some selected models of training in developed countries will be presented to compare the above mentioned to the world's fundamental models.

3.2 Maritime Education and Training (M.E.T.) IN THE Federal Republic of Germany.

Since 1970 most independent MET schools in FRG have been amalgamated with other colleges of Higher Education to form large polytechnics and so become departments within the polytechnics.

The MET schools offer the main professional courses leading to different certificates of competency for the deck department issued by the Federal Ministry of Transport, as well as a number of short courses for seafarers, shore-based personnel from the shipping industry and port authorities. As maritime departments of polytechnics award the degree of Maritime studies to their

full time students.

The objective of the professional courses offered by any maritime school in the FRG is to prepare candidates aiming at certificates of competency for deck and engine departments for their future profession aboard ship or ashore in the shipping and transport or other related industries and bodies.

These courses educate and train the students to be able to apply the principles taught and the insights gained to any task with which they may be faced in their career. The certificates issued by the Federal Ministry of Transport are:

Licences for Deck Officers and Masters	Licences eng./ship Electrical technicians
1. Deck Officer/Master near continental trade (limited 1000 GRT)	1. Ship's electrical technician or state examined technician
2. Deck Officer/Master foreign going trade	2. Engineer Officer continental trade up to 600 kw propulsion power.
3. Deck Officer/Master foreign going trade (unlimited tonnage)	3. Chief Engineer up to 3000 kw
	4. Chief Engineer Officer up to 8000 kw

5. Chief Engineer Officer
unlimited
propulsion power.
(all trading areas)

The licences for ship's electrical technician and engineer officer (nautical) are not part of the three different schemes. The admission for professional training aiming at three different licences corresponds to three levels of general education. The general education starts at the age of six. Three different levels can be achieved: the lowest level after nine years of schooling plus a general certificate of education; the medium level after ten years; and the highest level after 12-13 years.

It has become possible during the last few years for officers holding a medium licence to be upgraded to deep sea master or chief engineer (unlimited tonnage) by additional general and professional studies.

Some maritime schools are authorised by the Federal Ministry of Transport to set and hold examinations and the Federal Ministry of Transport issues the appropriate certificate after the candidate has been declared successful in an examination. After the required sea service, aboard a ship, presently nine months, appropriate to the class of his certificate, the holder may exchange his watchkeeping certificate for the corresponding Master's/Chief Engineer certificate without any further studies or examinations.

Students aiming at the highest class of certificate follow

the polytechnic course: a three year full time degree course at first degree level at the end of which they are awarded the polytechnic degree in nautical science or engineering and obtain the highest certificate of competency from the Federal Ministry of Transport. Thus, they are not only qualified to serve as deck or engine officers but also to enter marine oriented industries, administrations and other activities. The degree is aimed at the technology and business methods of the marine field.

Hence, students seeking employment in the management of shipping or other related industries, rather than serving as ship's officers, can follow the degree course after industrial training instead of doing the sea service necessary for the certificates of competency.

According to the tonnage of vessels, navigation areas etc, the qualifications and certifications of officers are shown in Appendix A.

Simulator Training Course.

A simulator-based training course is designed to enhance the potential engineer's decision-making skills as they apply to engine room watchkeeping situations. Practical demonstrations are made. Emphasis is also placed on the development of correct engine room procedures.

3.3 The Polish Training Model

The Merchant Marine Academies in are specialized technical universities educating and training future officers for merchant ships and specialists in the maritime industry. The Academies also offer postgraduate officer training and specialized courses.

All graduates obtain a Msc degree of a given specialization. Employees of shipyards and harbours can take evening courses in ship equipment repairs and seaport management. Intramural studies include five specializations:

1. Marine Transportation (Navigation),
2. Operation and Maintenance of Marine Power Plant,
3. Marine Catering,
4. Marine Electrical Engineering, and
5. Marine Electronics.

The duration of studies is 10 terms (5 years), including the practical training period. About 450 graduates of all specializations are granted diplomas each year in two Polish Academies. The curriculum includes three groups of subjects:

1. General Subjects--45% of all studies
2. Vocational Subjects--25% of all studies
3. Specialization oriented Subjects--30% of all studies.

Studies at all faculties lead to a Master of Science degree based on satisfactory evaluation of the Master's

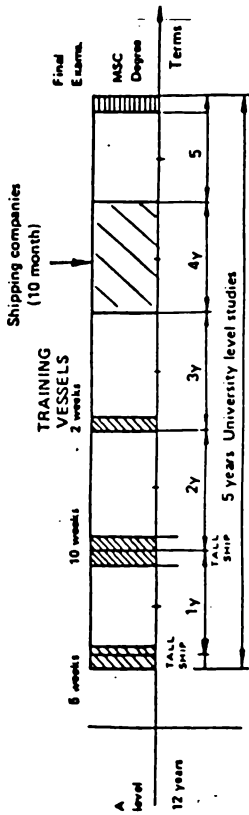

THE POLISH MODEL OF TRAINING

FIGURE 21

Thesis and passing the final examination. After having completed the required sea going experience, graduates obtain the Junior Deck officer's duties on merchant fishing vessels (see Fig.21)

3.3.1 Proficiencies and Updating courses in Poland.

Officers are trained in the Training Centre. As a separate administrative structure of the Merchant Marine, academies in Poland conduct and organize:

- __courses for certificates of competency examinations,
- __specialized courses designed to improve knowledge of the technical and technological developments in the marine industry,
- __proficiency and updating courses for senior officers of various specializations.

Training courses are based on academic programmes which comply with all requirements of international conventions, resolutions and IMO recommendations. There are four forms of courses: intramural, full time, long, and short term courses. The lecturing staff for these courses are attached to the Marine Academy. The average weekly teaching load amounts to 36 hours.

Simulator Training Course.

A similar training course to all of the courses described above is also given.

3.3.2 Academic Staff Qualification

In view of the close interrelationship between the science and application of modern technology in East European shipping, officer training must concentrate more on the operation processes of the automated and more complex ship systems.

The realization of theoretical and practical training of future ship officers is dependent on highly qualified teaching personnel. Maritime Education in East European academies is of a long standing tradition. This experience made possible the elaboration of new methods of qualification for academic staff.

According to governmental regulations, all academic staff are obliged to hold a scientific degree, foreign sea-going certificates and adequate professional and didactical experience. This is difficult, but it is the most cost effective way for developing professional staff in the Maritime Academies in the East European countries.

The carrier of an academic teacher with professor degree and Master Certificate connected with some sea-going experience as master or Chief Engineer takes about 20 years after graduation from the Maritime Academy.

3.3.3 THE OUTLOOK FOR TRAINING SYSTEMS OF THE EAST

----- EUROPEAN COUNTRIES. -----

Far-reaching function integration of a ship's crew is connected with the significant reduction of crew number and cannot be foreseen on board of the E.E. shipping ships. Generally in shipping, one solution for reducing operating costs is to develop a new manning system which will reduce the number of personnel on board the ship.

Some forecasts of reduced crew numbers are connected with introducing new less fuel-consuming technology, automation and higher reliability of ship systems. It has become obvious that the future seafarer will likely be a person of multi purpose capabilities.

Today the most popular and generally maintained manning system of the E.European shipping companies is the mono-valent system. There are three reasons why this system of manning is maintained:

- the technical aspect,
- the employment aspect,
- the economic aspect.

In our view, the technical standards of ship systems are not yet perfect enough to allow the introduction of a full-time unmanned engine room on all types and sizes of ships. There are ships with A-16 class of automatics operated in common use.

There are different ways of operating a modern ship:

1. fully self-maintained and managed ship,
2. no-maintained and managed ship,
3. essentially self-maintained and managed ship.

The first and third ways of operating are very popular in E. European shipping companies, so there is no possibility to reduce the crew to the very bare minimum.

Another reason for this is the fact that the personnel costs there in the shipping companies are considerably lower in comparison with other European countries.

These are the reasons why the bivalent system has not yet been introduced on board many merchant ships.

I would like to conclude as follows:

The new ships have come into operation with considerable changes resulting from the introduction of modern microtechnology.

The navigation bridge layout is designed for one-man operation due to the recent IMO consideration of the navigation watch as the sole lookout.

The mooring operation is designated to be operated by a minimum number of crew.

Life-saving and fire-fighting appliances are of a high standard to enable operation by reduced manpower. The engine room is controlled and monitored from the ship's operation room and is unmanned for some period daily. The models of maritime education and training are monovalent and are expected to be maintained for some years into the 90's with some changes. Maritime Academies

are maintaining the monovalent model of training due to the following reasons:

--Graduates are preparing for manning of the national ships only (except Poland),

---Due to tight schedules of operation, ship crews spend more man-hours on maintenance and cargo handling, thus reducing stevedore work loads and dockyard repair costs.

---The reliability of ship systems is not high; therefore, the number of crew must be sufficient to operate a ship when automatic control devices break down,

---The personnel costs of ship operation in E.European shipping companies are still low,

---The E.European maritime transport system works at such a vantage point that technical and economical problems have merged into safety and social questions.

3.3.4 CONCLUSIONS

1. The Academies convey the latest international results of research in the fields of navigation, engine operation, cargo handling and transport technology including social, economic and legal aspects.

2. Special emphasis has been given in the syllabi on safety and the environmental protection problems.

3. To reach this aim it is necessary to increase the information exchange flow between the IMO and the world's

training institutions. This can facilitate the delivering of lectures on the latest international achievements and results of basic and applied research,

4. Major objectives must be drawn on students education and their level of training by systematic qualification upgrading of the teaching staff including their sea going experience.

5. In fact, every academy has its own flexible and dynamic concept or plan of upgrading staff qualification. The qualifications generally required are a scientific degree from a maritime academy and sea-going experience together with relevant certificates. This is one of the longest and most cost-effective ways but necessary to keep good qualified personnel in the academies.

6. There is a need for periodically correcting and updating the syllabi in every faculty due to the dynamic development of marine technology in the international shipping.

7. In a maritime training institution there must be a close connection between theoretical and practical training based on methods.

8. The level of qualification of the academic staff plays the main role in promoting standards at the students' level.

3.4 MET IN THE UNITED KINGDOM:

In the U.K., the established service scheme was introduced in 1974 to replace the reserve pool (which had been established by an essential work order during the Second World War) and to combat the casual nature of sea-going employment which had been the case before the war. The whole purpose of this scheme is to provide some security of employment and to provide a single source of supply of seamen. This source is jointly controlled by the employers and employees (various seafarers' unions). The scheme is administered and financed by the employers' commission, which plays a major role in the recruitment and training of most ratings, and also in seeking deck and engineer cadets for appointment to shipping companies. The whole recruitment policy is co-ordinated by the Merchant Navy Training Board.

Looking at entry standards, the most common entry requirement throughout the world is the completion of secondary school education; other requirements often vary depending on the choice of the course.

Range of Courses:

Main stream courses provide the education and training required by Deck and Engineer Officers to meet the needs of the shipping industry and to satisfy the certification requirements of the U.K. Department of Transport. BTEC courses lead to the award of National Diplomas and Higher National Diplomas in Nautical Science and in Engineering. Degree schemes are at an advanced stage of preparation and a significant number of maritime research projects are

being undertaken.

A wide variety of short courses in specialist areas is provided. These include the carriage of hazardous cargoes, safety, survival, firefighting, navigation and passage planning, shipboard management, on board training in engineering plant management, control engineering, welding and rating skills enhancement.

Marine Engineer Student Courses

Complex problems arising in the high technology of the modern automated merchant vessel, oil tanker, high speed container ship or sophisticated liquified gas carrier require accurate assessment, prompt decisions and effective corrective measures. The training involved in such a career is therefore detailed and requires dedication.

A career in marine engineering is not confined to service at sea; it offers employment not only in the many shore-based industries which provide the construction, maintenance and support services for the merchant fleet, but also in the engineering industries in general. The offshore industry in the North Sea has absorbed many marine engineers into their managerial structure. The training for the marine engineer is well diversified to cover the range of job opportunities.

An important part of the work of the engineering department involves specialized courses, among which are the Maritime Simulation Courses.

Maritime Simulation Courses:

These courses are run in the Maritime Simulation Centre which is operated by professional deck and engineer officers of the College lecturing staff. The Centre is equipped with two nocturnal ship simulators (electronically linked to provide an interactive simulation capability) and two radar simulators. Medium and slow speed diesel simulators complete the range of existing simulator facilities.

A manned ship model facility for shiphandling training complements the ship simulators all of which are backed up by well-equipped lecture and seminar rooms.

The combination of ship simulators and manned model training provides a unique facility for the training and upgrading of pilots. The Centre is at the forefront of advanced maritime simulator training and is now developing a strong applied research programme.

Courses

Bridge Watchkeeping Preparatory (2 weeks)

Bridge Organization & Teamwork (2 weeks)

Emergency Procedures (3 1/2 days)

Manned Model Shiphandling (5 days)

Automatic Radar Plotting Aids (ARPA) (2 1/2 days)

Navigation Control (2 weeks)

Vessel Traffic Service (5 days)

Radio Surveyors Radar (5 days)

Radar Refresher or Familiarisation (to suit a particular client)

Panned Operation for Marine Engineer Officers (5 days)

In addition to the above courses, a range of diesel engine simulator based training programmes can be designed for cadets and ratings through to senior engineer officer requirements- from basic watchkeeping duties to emergency situations and efficiency/fuel conservation concepts.

3.5 MET in The U.S.A.

Maritime Education and Training in the U.S.A. goes back as far as 1874 when a two-year "scholarship" curriculum was conceived by Stephen B. Luce (later Admiral of the Navy). Just after World War II, a four-year course was instituted to train young men as deck and engine officers.

The aim of the Academies is to train young men and young women as officers in the American Merchant Marine to operate commercial ships and also serve in such other capacities as ship designers (naval architects), maritime lawyers, port engineers, shipping company executives, naval officers, Coast Guard officers and oceanographers.

A four-year course leads to the Bachelor of Science degree and a US Coast Guard Licence as a Third Mate or Third Assistant Engineer or both. In addition, the students are enrolled as midshipmen in the US Navy Reserve and, if eligible, are commissioned upon graduates as Ensigns in the US Navy Reserves.

At the Federal Merchant Marine Academy in King's Point, New York, the training is based on four major programmes:

- Marine Transportation for the preparation of deck officers;
- Marine Engineering and Marine Engineering Systems

for the preparation of Engineering Officers. Marine Engineering Systems programme , in addition to leading to a Third Assistant Engineers' Licence, is accredited by the Accrediting Board for Engineering and Technology. This curriculum includes greater depth in mathematics and a significant engineering design component as compared to the Marine Engineering curriculum.

All midshipmen must also take Naval Science courses prescribed by the department of the Navy. The academic year at the Academy is divided into four academic quarters which span about eleven months,generally from the last week of July to the end of June.

All four classmen follow a common programme of study for the first two quarters of their freshman year (first year). During this period, in addition to basic courses in mathematics, science and the humanities, every shipman takes introductory courses in nautical science and marine engineering. The new shipman is thus given an opportunity to determine intelligently an area of spcial interest before choosing a major field of concentration.

As part of the professional training, each midshipman participates in a cooperative educational programme consisting of two quarters of the sophomore year (second class) and two quarters of the junior year (third class) at sea (approximately five months for each sailing period) aboard commercially operated merchant ships.

The shipboard training programme provides all shipmen with the opportunity to use a ship as a sea-going laboratory. Midshipmen are given a study guide called a "sea project" and, in addition to performing shipboard duties are

required to complete written assignments which are submitted to the Academy for evaluation and grading.

The assignments are carefully designed to ensure that, while aboard ship, midshipmen apply the knowledge and skills learned in the academy classrooms and acquire a firm foundation for advanced study upon their return to the academy. Aboard ship, marine transportation students are assigned to the deck department, and engineering students to the engineering department where they spend half of their time at sea.

Between periods of shipboard training during the sophomore and junior years, each midshipman returns to the Academy and continues academic work in his or her chosen field. Every midshipman is required to complete a specific number of elective courses.

To meet the elective requirements, midshipmen may choose an elective course for which they have the prerequisites, or they may complete a prescribed sequence of courses leading to a concentration in a specific academic discipline.

The four-year programme of study at the Academy is shown in Appendix 2.

For the grading of written assignments, laboratory work and examinations, a letter grading system with corresponding quality points is used.

Quality point values per quarter credit hour are assigned in accordance with the following table:

Letter scale	Quality point value
A	4.00
B+	3.50
B	3.00
C+	2.50
C	2.00
D+	1.50
D	1.00
F	0.00

To be eligible for graduation, a midshipman must, as a minimum, satisfactorily accomplish or complete the following:

- Pass all required courses
- Earn the minimum number of credit hours prescribed for his/her curriculum
- Earn a cumulative Quality Point Average of at least 2.0
- Pass the appropriate US Coast Guard Licence examination
- Apply for and accept, if offered, a commission in the US Naval Reserve
- Complete satisfactorily an appropriate intership programme.

The choice of the required course of study depends on the student's ability to take more majors. However, a minimum 3.00 quality point average with strong math/science grades during the first quarter of plebe year is usually required for consideration.

Admission Requirements:

All candidates must meet certain requirements of citizenship, age and moral character, but the Academy

considers qualified candidates without regard to race, color, sex or national or ethnic origin.

To be eligible for admission, a candidate must be an American citizen, at least 17 years of age and not older than 25 and of good moral character.

Candidates must meet the physical, security, and character requirements for appointment as midshipman, US Naval Reserve. Applicants must have satisfactorily completed a high school education at an accredited secondary school or the equivalent and have earned at least 15 units of credits. Included in the credits must be at least three units of English, three units of mathematics (algebra, geometry and trigonometry) and one unit of either laboratory physics or chemistry.

Foreign students who wish to enrol at the Academy are subjected to the same entry requirements as the US citizens but the nominating authority -- instead of a member of congress--it should be the representative of the maritime administration or a diplomatic representative of the United States in the candidates' own country of residence who will be designated as the candidate's sponsor.

An indoctrination programme is conducted during the first two weeks after arrival of the new class. It is an extremely intensive programme, both physically and mentally. The aim of the indoctrination programme is to provide a basic orientation, to instill motivation, and to develop a sense of achievement and pride in the plebe candidates.

Licensing of Maritime Personnel:

Candidates for the higher grades of Licence such as second Mate or second Engineer up to Master/Chief Engineer, are requested to sit for an examination in order to demonstrate their proficiency and qualifying experience. The licencing is carried out by the US Coast Guard Marine Inspection.

During the year, several periods of examination are programmed and tests last from four to five days. Prior to sitting for a licence examination, applicants must meet certain requirements.

Applicants must be at least 21 years of age with the exception of third mates who must be at least 19 years of age. A minimum qualifying sea experience is required for each grade of licence.

The basic requirement is one year of sea service as second mate or second engineer to qualify for chief mate or first engineer and one year sea service as chief mate or first engineer to qualify for master or chief engineer. All applicants must be citizens of the United States. A licence application may be obtained by a written request.

All statements of sea service must be supported by documentary evidence, issued by responsible persons, i.e. officers in charge of related organizations.

Upon acceptance and approval of his application for a licence, the candidate will be sent for a physical checkup.

Simulator Training Course.

Simulator training courses are given at State University of New York, Maritime College, Ford Schyler and US Merchant Marine Academy, Kings Point, N.Y.. The course contents and the training systems are similar to those described in the previous chapters.

CHAPTER 4

PROPOSAL FOR ENHANCING THE USE OF EXISTING FACILITIES

4.1 The Transfer of Shipping Technology to Developing Nations.

Education plays a great role in the development of any nation. Only an educated people can command the skills necessary for sustainable economic growth and a better quality of life.(1)

Recognizing this, the Government of Cote D'Ivoire has placed heavy emphasis on expanding educational opportunities from Primary School through University since its independence in 1960. The number of students enrolled in National Institutions at all levels has more than quintupled. Today in Cote d'Ivoire we can find many institutions of higher education such as INSET (Institut National Superieur d'Enseignement Technique), a kind of Polytechnic institute which comprises five schools and other schools such as Ecole Internationale d'electricite, Ecole Internationale de Statistiques and Ecole Superieure d'Agronomie.

In recent years, the Maritime Academy of Abidjan (Academie des Sciences et Techniques de la Mer) has also been added in order to respond to maritime demands.

Indeed, many developing countries which, at one time depended heavily, if not completely, on the established shipping companies of the developed maritime nations for their import/export trade, have, over the past decade, become shipowning and operating states. This has been

possible through bilateral or other arrangements, such as joint venture schemes, with established lines trading into or across regions.

In the initial stages of their entry into the shipping field, these developing nations made use of expatriate maritime expertise for ship management and crewing. At the same time, modest training programmes were set up, making use of facilities in the developed maritime countries to satisfy their quite modest needs.

With an accelerating acquisition of tonnage, the developing countries have reached the stage where it is economically feasible to establish their own national maritime training centres. Over the past few years, this trend has increased quite a lot, leading to developing countries, in particular, Cote d'Ivoire, crewing their own flag vessels with their own nationals who have been trained in their own National Maritime Centres.

This transformation of the developing countries into states which own and operate ships is not confined to one or two areas or regions but is taking place on a world-wide scale in Latin America, the Caribbean, the Middle East, Africa, Asia and the Pacific. This will, without any doubt, create more competition in world trade.

In spite of their efforts, it has been observed that in most of the developing countries, the facilities available for development are not used as efficiently as required.

(1) Education in Sub-Saharan Africa: a World Bank Policy Study Report (January 1988).

This situation clearly requires a special attention. To help the interested reader fully understand these problems, I have stressed the importance of using a simulator as a training aid.(2)

In order to streamline the national and regional maritime education and training especially for marine engineers, I find it necessary that the Maritime Academy be the "focus of knowledge and training in maritime affairs". The Academy therefore should broaden the variety of courses under the supervision of the Ministry of Education to serve and safeguard the national and regional maritime interests.

Having the necessary educational facilities, Abidjan Maritime Academy should assume the responsibility to conduct useful maritime education and training courses on subjects of not only marine affairs but also on the applications of the simulator as listed broadly in the following areas:

- professional training;
- undergraduate training;
- development of existing facilities and practices;
- extension of the simulator to accomodate new fields of studies;
- research into new facilities.

(2) Reports of July 13, 1990 on: Project Developments in Developing countries (European French Broadcasting: case of Cote d'Ivoire: sugar complex of North).

4.2 The International Framework.

International Shipping is constrained to operate within a voluntary framework of international codes, conventions, and other instruments, developed through the United Nations and its specialized agencies, in particular, the International Labour Organization (ILO), the United Nations Conference on Trade and Development (UNCTAD), the United Conference on the Law of the Sea; and the International Maritime Organization (IMO).

The main ideas underlying the development of this framework have been: social, economical and other factors in the employment of of seafarers (ILO), cargo sharing and other provisions in the operation of shipping (UNCTAD), equitable sharing of the world's undersea resources (Conference on the Law of the Sea) and safer ships and cleaner oceans (IMO).

It is understood that such an international framework having been set up by the participating nations forming the specialized agencies of the UN, it is theoretically possible for a country to operate outside of this framework.

But many countries around the world participate in these agencies and, with the introduction and further development of practices such as port state control, unilateral action by any country is impossible.

Over the past few years, the UNCTAD Liner Code, with its sharing philosophy, has had an influence on world tonnage. This will probably change the world shipping structure in the years ahead.

IMO has been a world-wide forum for all nations who have an interest in shipping and the sea over the past 25 years. The number of participating states has risen today, IMO's influence having increased through its consideration, adoption and implementation of many measures for improving the safety of international shipping and the preventing and controlling of pollution from ships.

So far, IMO has promoted 31 International Conventions or other treaty instruments, codes and recommendations of various kinds, all related to merchant ships with regard to construction, equipment and operation.

Among these Conventions, three are considered as being the most important and having the biggest impact on merchant ships: SOLAS 74/78, MARPOL 73/78 and STCW 1978. But the Convention which is relevant to this paper is the STCW 1978 or "The International Convention on Standards of Training, Certification and Watchkeeping of Seafarers, 1978".

This convention came into force in April 1984 and provided, for the first time, on an international scale, minimum standards for seafarers in terms of the levels of theoretical and practical knowledge, linked to professional experience and understanding required for the certification of professional competence of Seafarers.

4.3 The Impact of the STCW 1978 Convention.

The STCW 1978 Convention was held in London in 1978 and

adopted by the countries forming the International Maritime Organization (IMO) at that time. Most of them were developed countries which had already established maritime infrastructures, with education and training programmes for their seafarers which could meet the majority of the Convention requirements.

It took time between the adoption of STCW and its coming into force, a period allowing some countries to make adjustments to their maritime and training programmes.

The developing countries were not prepared to overcome the many problems they had in meeting the requirements of this international convention.

The main problem of many developing countries was to have an appropriate National Maritime Administration responsible for the control of:

---- ship registration, surveys, pollution control;

---- a system for the examination and certification of seafarers;

---- the levels of education, training and experience required by the issuing of certificates of competency.

Nevertheless, the countries recognized, through assistance either from the IMO Technical Assistance Programme or from direct contributions, the importance of the Convention as a set of objectives through which economic strategy could be developed in an organized and structured manner. This had a benefit to developing countries in terms of

technical skills acquisition in the long run.

IMO has worked hard to develop its Technical Assistance Programme which today covers many maritime areas such as, maritime legislation, radio communications, shipbuilding and ship repairs, and, of prime importance, maritime training.

The most ambitious and exciting of all IMO's Technical Assistance projects is the World Maritime University at Malmo, Sweden, which opened in 1983. It's objective is to provide high level training facilities for personnel from developing countries who have already reached a relatively high standard in their own countries but would benefit from further intensive training.

The courses provided are: maritime safety administration, maritime education, technical management in shipping, and maritime administration. The majority of the courses are of two (2) years' duration and, in most cases, will lead to the award of a Master's Degree.

4.4 Proposals for enhancing the use of existing facilities.

The proposed programme to enhance the use of existing facilities for the marine engineering studies in the Regional Academy in Abidjan, Cote D'Ivoire is based on :

----My own experience as a marine engineer officer (1st class) and on experience gained while following the two year course at World Maritime University. This included field trips to many maritime institutions throughout the world, among which the Polytechnics Institute of Flensburg

(F.R.G), the Maritime Academy in Szczecin (Poland), the College of Maritime Studies in Southampton (U.K), the United State Maritime Academy in Kings Point, N.Y.(U.S.A), the State University Maritime College in Bronx, New York (U.S.A) and the U.S Coast Guard Academy in New London, Connecticut (U.S.A).

I also think that a flexible programme such as those of the above institutions, could allow one to have the option to continue seafaring as a career or enter a shore based industry as a career, thus avoiding probable unemployment problems.

As an example, in Canada, the majority of graduates from the "Institut de marine de Rimouski", Quebec, after sailing as Chief Engineer for a reasonable time, can find shoreside jobs easily. This is not the case of those from developing countries who, to their dismay, find difficulty in having their credentials recognized by concerned authorities.

In view of the preceding arguments, my proposed programme will permit:

---- the fulfillment of the wishes of marine engineers in general and an equivalence between other kinds of engineering schools through requisite credentials which are recognized by competent National Authorities such as engineering universities, for example, the "Ecole Nationale Supérieure d'Enseignement Technique"(INSET).

---- marine engineers to have the possibility to enter the national engineering education system more easily and establish themselves ashore without any hindrance.

---- to continue further studies in some other disciplines as a career if they wish.

This programme also takes into account the modern technological impact on the present day merchant ship. Due to the ratification of the STCW Convention 1978 by the Government of Cote D'Ivoire, certain mandatory courses have been introduced in order to comply with the international requirements.

4.4.1 Objectives.

The main objectives of the simulator training courses are:

---- to give the trainee better understanding of a modern diesel propulsion plant, especially when malfunctions occur.

---- to refresh the marine engineer's knowledge of diesel propulsion plant principles.

---- to improve his professional skills in the safe and efficient operations of complex propulsion machinery.

---- to increase the junior engineer's confidence in handling remote controlled machinery through "hands on" operations such as demonstrating and testing the effect of varying parameters, and component deterioration on plant behaviour: cylinder pressures (P_i , P_{max} , P_{comp}), rpm, air filter pressure drop, air temperature, oil temperature for turbo charger, efficiency of air cooler, short circuit, frequency, voltage, load in diesel generators, sea water temperature, lubricating oil pressure, etc.

---- to provide an opportunity for the trainee to handle extensive failures which are either dangerous, difficult or exceedingly costly to conduct on board ship.

---- to practice routine operations (such as daily work as an engineer on duty) and non routine operations.

---- to familiarize the trainee with new unmanned diesel engine room which include alarm systems, remote controls of propulsion plant, alarm logging, condition monitoring, remote control of all pumps and automation systems.

---- to improve operating practice with respect to saving energy and optimizing fuel economy. For example, some of these studies include:

- . the calculation of heat balance, heat recovery and their influence on fuel oil economy;

- . the differentiation between external and internal causes of deterioration in performance;

- . the effect of wrong fuel oil injection timing, poor fuel oil quality, viscosity, nozzle wear, combustion performance;

- . optimizing studies on main engine load and variable pitch performance;

- . the influence of external conditions such as weather, sea state, air and sea temperature on fuel oil economy.

- . the effects of deterioration (fouling and wear) in

various components such as pumps, coolers, hull, piston rings, actuators, valves.

The operational feature of the engine room simulator is of particular value as it trains engineers in procedures to arrive at improved fuel economy, a subject of ever increasing importance these days.

4.4.2 Simulator Training Course.

"Tell me and I shall forget
Show me and I shall remember
Let me do it and I shall understand".

(Chinese Proverb)

The training is designed to improve the professional skills in the safe handling of a complex diesel propulsion plant. During a training course, classroom and "hands on" instructions are given.

"Hands on" instruction on the simulator gives the engineer the opportunity to put into practice his theoretical understanding of the system.

The quick diagnosis of malfunctions and their correction before developing into damage to the installation is particularly stressed. The effect of changing parameters on plant behaviour is also demonstrated.

All courses are conducted under the guidance and supervision of instructors who themselves are experienced Chief Engineers.

For reasons of course effectiveness the number of course

participants has been set at five (5), although it is possible to accommodate a greater number of trainees.

Several courses are proposed:

---- a course to suit the specific needs of the experienced senior engineer. Stress is placed on economic plant operations.

---- a course adapted to the requirements of the less experienced junior engineer. The greater part of the course is devoted to safe plant operation and trouble shooting.

---- a course to assist diesel engineers when converting to steam turbine operation.

---- apart from a contribution to the training of nautical personnel for dual licensing, engine room simulator training may also assist Masters, Mates and Pilots in gaining more insight into engine room operations and its effects on vessel maneuvering capability.

The programme for any training course is set up in consultation with the shipping companies of the participating countries of the regional project. This will ensure that the course meets the needs of those companies, that is, of course, to the extent permitted by the simulation equipment.

Finally, although the training simulator represents a specific plant, the training courses stress procedures in how to cope with situations that may occur in any diesel propulsion plant. Hence the training can be transferred

to any diesel installation operated from a control room.

4.4.3 Instructors.

Two instructors conduct the training course. The first instructor teaches the fundamental theory of diesel plant operation, while the second instructor deals with control engineering and the practical and operational aspects of diesel propulsion, one at a time.

Both have to cooperate during all sessions and be capable of exchanging tasks should the need arise. They are constantly present because the course is very intense. They should have a similar professional background and hold at least the rank of Chief Engineer. An instructor can best transmit information if he has similar experience himself.

4.4.4 Execution of the Training.

The number of the trainees is kept to five (5). But a shipping company is free to send more trainees if considered necessary. During "hands-on" instructions, the trainees are split into groups. One group carries out an exercise, the other group acts as critical observer. The groups alternate. In conducting the exercise, the engineers function as chief engineer, assistant engineer and reporter. These functions rotate. Table 1 gives an example of a time schedule for experienced trainees.

However, there is sufficient flexibility built into the programme and in the simulator potential to adapt the training to the needs of the individual trainee. This is necessary because of differences in knowledge and/or

experience levels.

During the training course, procedures described in the operating manual of the actual installation are followed. By doing so, the engineers realize the importance of following manufacturers' or other companys'instructions.

CURRICULUM FOR SIMULATOR TRAINING COURSE.

Target Groups:

G 1: chief engineer

G 2: second engineer

G 3: third engineer

B 1: cadets with seagoing experience

B 2: cadets without seagoing experience

C 1: instructor with simulator⁺ experience

C 2: instructor without simulator experience

Overall objectives:

The participants shall learn to optimize ship operations following defined safety and economy requirements through confrontation with realistic situations and developments.

TABLE-1: SIMULATOR TRAINING COURSE FOR
CHIEF AND SECOND ENGINEER OFFICERS

DAYS	TIME	SUBJECTS
Monday	09.00-10.15	Introduction: 1. introduction to simulator course. 2. explanation of training manual. 3. familiarization with simulated ship: working principles.
	10.15-12.15	Orientation exercise: normal operation and control procedures: alarm system and communication system used.
	14.30-16.00	Orientation exercises (continued):
	16.15-17.00	Exercises: discussions.
Tuesday	09.00-10.30	Automatic versus manual operation 1. main engine condition monitoring: warming up, cooling down, starting, reversing, load changing. 2. starting and stopping of diesel generators and turbo generator parallel, running of generators, generator changeover, blackout and recovery.
	10.30-12.00	Automatic vs manual operation (cont) 1. auxiliary boiler and exhaust: gas economizer remote control manual and automatic on-off control. 2. pumps, compressors, oil purifiers and distilling plant start-stop and open-shut control of valves associated with them.
	14.30-16.00	Automatic vs manual operation (cont)
	16.15-17.30	Automatic vs manual operation (cont)

TABLE-1: SIMULATOR TRAINING COURSE FOR
CHIEF AND SECOND ENGINEER OFFICERS (continued).

DAYS	TIME	SUBJECTS
Wednesday	09.00-10.30	<p>Energy balance and performance monitoring:</p> <ol style="list-style-type: none"> 1. discussion on sources of plant losses, heat balance and method of fuel saving. 2. restoration to normal conditions.
	10.00-12.00	<p>Exercises:</p> <p>abnormal condition setting including tripping, reduced capacity, fouling and low level of the main engine, generators, auxiliary boiler, pumps, heat exchanges, tanks, etc...</p>
	14.00-17.00	<p>Exercises (continued) into groups:</p> <ol style="list-style-type: none"> 1. demonstration of effects of process parameters affecting plant performance. 2. slowdown operation. 3. study of various problems associated with prolonged reduced power operation. 4. appropriate sea state mode failure. 5. indicator diagrams setting. 6. piston rings monitoring. 7. metal temperature monitoring of cylinder liners and head covers.
Thursday	09.00-10.30	<p>Continuation of exercises:</p> <p>study of various problems associated with: cylinder fault detection, engine condition analysis and trend prediction of engine wear.</p>
	10.30-12.00	<p>Control theory and exercises:</p> <ol style="list-style-type: none"> 1. discussion on control theory. 2. description and demonstration of control loop tuning methods.
	14.00-17.00	<p>Exercises:</p> <p>comparison between automatic and manual operation of critical plant parameters.</p>
Friday	09.00-10.30	<p>Sea state mode exercises:</p> <p>various fault condition exercises such as emergency running.</p>
	10.30-12.30	<p>Continuation of exercises.</p>
	14.00-17.00	<p>Free form and course evaluation.</p>

Group objectives:

G 1/chief engineers:

The experienced chief engineer, well familiar with all routine tasks, shall develop a strategy to avoid errors, involve their officers in the decision finding process and cope with emergency situations.

G 2/second engineers:

The participants shall become familiar with all operational tasks normally carried out with the chief engineer, assist the chief engineer in difficult situations and be able to take over the chief engineer's position should the need arise.

The proposed programme is for chief engineers as well as second engineers sent by shipping companies. The general programme with exercise modules is in Table 1.

The second programme is for watchofficers of group G 3 (3rd officers) and for cadets in their 4th year at the Academy.

Overall Objectives:

The participants shall understand and learn what information is needed for the decision finding process. They shall be able to select and evaluate relevant information, then decide and communicate within the man-ship environment. All watch officer routine tasks must be carried out responsibly.

TABLE-2: SIMULATOR TRAINING COURSE FOR
WATCHKEEPERS (3rd Engineers) AND STUDENTS

DAYS	TIME	SUBJECTS
Monday	8.30-10.30	Ship systems I: 1. study of design principles. 2. characteristics and classification of marine diesel engines.
	10.30-12.15	Ship systems I: (continued) 1. construction specification according to International Safety Regulations. 2. engineering regulations.
	14.00-16.00	Ship systems I: (continued) correct procedures for operation and maintenance of auxiliary and main engine diesels.
	16.15-17.30	Ship systems I: (continued) fuels and combustion; diesel operation using simulator, miscellaneous systems.
Tuesday	08.30-10.30	Ship systems II: basic principles, construction and description of ship main propulsion engine and their support components.
	10.45-12.30	Ship systems II: (continued) brief description of steam reciprocating engines, a detailed treatment of steam turbines and electric drive systems together with the auxiliary components which comprise a complete plant.
	14.00-17.00	Summary: 1. Ship systems I 2. Ship systems II 3. Open discussion.

TABLE-2: SIMULATOR TRAINING COURSE FOR
WATCHKEEPERS (3rd Engineers) AND STUDENTS

DAYS	TIME	SUBJECTS
Wednesday	09.00-10.30	Maneuvering mode exercises: watchkeeping, monitoring and logging systems, automation systems of pumps, purifiers, compressors.
	10.45-12.45	Automatic versus manual operation systems: 1. auxiliary boiler and exhaust gas economizer, manual and automatic on-off control. 2. pumps, compressors, oil purifiers and distilling plant start-stop and open-shut control of valves associated with them.
	14.30-16.00	Exercises: comparison between automatic and manual operation of critical plant parameters.
Thursday	08.30-10.00	Introduction. 1. introduction to simulator course 2. explanation of training manual 3. familiarization with simulated ship: working principles.
	10.15-12.15	Introduction (continued).
	14.15-16.45	Orientation exercises: normal operation and control procedures: alarm system and communication system used.
Friday	08.30-10.00	Orientation exercises (continued): engine room plant; ship mode operation; mode changing such as from dead ship, port service, main engine warming up, stand-by, run up, normal navigation to port entry.
	10.15-12.15	Orientation exercises (continued)
	14.30-16.00	Exercises: discussions. evaluation of training course.

G3/watch-officers

All routine tasks must be carried out responsibly. Risky emergency situations, which can arise very quickly, must be managed without assistance.

B1/cadets with seagoing experience(students)

The participants must be able to stand an engine room watch under normal conditions. They must be able to define situations and developments when competent assistance is needed and establish this assistance by early and proper information. Generally, they assist officers on watch.

The proposed programme stresses the fundamental theory of diesel plant operation. Table (2) gives the time schedule.

Groups C1-C2

Simulator instructors with and without simulator experience.

Duration: 1 or 2 weeks, 8 hours per day.

Contents: according to entrance qualifications and experience, hardware to be operated and trainees' experience.

4.4.5 Implementation and Evaluation of Simulator

Training Course:

For the effectiveness of the training course as stated earlier in this chapter:

---- the number of the trainees or cadets should be a minimum of 5 for example. This will allow each trainee to achieve the objectives, as he/she has to stand several watches as the watchkeeping officer. The effectiveness of the course would be greatly reduced if several trainees shared a watch.

---- the trainees should be experienced officers, watchkeepers or cadets of junior year level. The intention at this stage is that the course will come at the end of the cadets' qualifying sea service, and act as a means of consolidating his/her experience and skills.

However, cadets (students) without sea experience may also be trained. At this stage before they stand watches, they may have the opportunity to avoid "bad habits".

---- The students' roles should rotate through the exercises.

---- Two instructors should be appointed and also rotate.

---- It should be ~~bone~~ in mind that the course will be adopted nationally and regionally. The structure therefore, should be flexible enough to cater to the varying capabilities of all the simulator operators.

At the end of the training course, an evaluation should be

made and a certificate given to each trainee. This evaluation will give a feedback to the administration of the Academy for future improvement and development.

4.4.6 Importance of Providing Specialized Maritime Short Courses as an Aid to Improving Standards.

In addition to the present short courses being run at the Academy such as:

- . tanker safety course
- . chemical tanker safety course
- . fire fighting
- . LPG/LNG tanker safety course.

it would be important to conduct the following courses not only for the purpose of helping the trainees master the principles in the simulator training course but also to comply with the national Educational Engineering Board Curriculum:

---- SHIP AUTOMATION:

- . Aim: to improve professional knowledge of marine engineer and electrical engineer officers in ship automation.
- . Scope of studies: computer programming; digital and analog technique, micro processor; selected specialist problems of particular groups of trainees-

ship control systems and equipment; thrusters; ship stabilization systems, navigation and collision avoidance systems; automation of the main engine and auxiliaries; marine plant automation monitoring and measurement systems; reefer automation. Practice onboard ship and manufacturing plants.

---- MICRO-COMPUTER SHIP AUTOMATION SYSTEMS:

- . Aim: to train and improve professional knowledge of shore-based engineering and technical staff of shipping companies in micro-computer ship automation systems.
- . Scope of studies: principles of operation and programming of ship micro computer systems; maintenance, use and diagnostics of micro computer systems.

Other courses include General Cargo Storage for dockers in computer programming systems.

These courses should be run during special periods not affecting the continuous curriculum programme for students in full-time education. However, these courses may be run at the of shipping companies or maritime organizations and should be held by qualified and competent instructors or visiting guests.

Certificates of Proficiency should be issued to participants. Courses should comply with the requirements of the STCW 1978.

5.1 - CONCLUSION:

The introduction of new technologies which permit effective remote operation of shipborne machinery and the economic limitations which have resulted in unmanned machinery space (UMS) require that engineering officers of today's merchant marine be able to control and monitor ship's machinery in the environment of a Centralized Control Room.

Marine engineers must not only understand the fundamental workings of the machinery but must also be familiar with remote automation and monitoring systems.

When the engineer knows these systems, he can easily interpret instrumentation, react to warnings, understand procedural requirements, carry out emergency actions, and ensure that neither the ship, cargo, machinery or life are subject to hazards.

A diesel engine room simulator and associated training aids, in the form of equipment or documentation, constitute a form of "hands-on" training which is very useful and ensure that the trainee is fully conversant with the system. The engineer can recognize and correct quickly any emergency condition as and when it arises with confidence.

Another benefit gained from the use of a diesel engine room simulator is that this means generates an environment where a group of trainees may be trained in both operational and corrective procedures on equipment related

to realistic ship systems, where the maximum penalty for incorrect actions is limited to the embarrassment of the trainee knowing he/she has "got it wrong". This is sufficient to ensure a better understanding of the correct procedures should the same fault occur again.

I have mentioned earlier in the "Diesel Engine Room Simulator" section, some benefits that the use of a diesel engine room simulator can provide many benefits such as :

--A- The safety consideration, which is not negligible. A simulator training course permits the learner to be slowly introduced to the essential task characteristics, without any danger to himself, his fellow trainees or the expensive equipment. Simulator training also permits the trainee to practice emergency techniques before being exposed to hazardous situations in real settings.

--B- Cost savings: quite probably, the behavior of a beginning trainee handling a multimillion dollar passenger ship might convince passengers to make donations to simulator training programme. Some of training programmes I have attended during my field trips, namely:

1. the College of Maritime studies in Southampton in U.K
2. the State University College for Maritime studies in New York City.
3. the Polytechnics Institute of Flensburg, F.R.G.

use the simulator training course to train marine and offshore engineers. In this respect, the intention of this paper is to encourage the programme now being offered

at the "Regional Academy of Sciences and Techniques" of Abidjan and to incite the concerned authorities of the administration of the Academy to extend this training programme to the particular needs of the participating countries in the regional programme.

The Academy of Abidjan is properly equipped to impart the necessary education and training of marine engineers. Its facilities can be used to train marine and offshore personnel such as:

---- marine pilots for the ports of Congo, Zaire, Benin, Togo, Cote d'Ivoire, Senegal, Guinee Conakry and for some inland waters such as the Niger, used extensively for inland commercial transports.

---- seagoing officers as now is the case.

---- training of marine officers engaged in offshore activities such as the drydock "CARENA" or heavy industries and platforms in Abidjan.

---- training of tugboat personnel.

Tailored training system characteristics have been identified as necessary for the different groups of mariners to achieve maximal cost-effective training. But a well-planned programme can provide a positive and valuable contribution to marine engineers' training. With a revision of objectives, a better distribution of time allocation, improvements to the hardware systems and the training techniques and instructional skills, the training system could be even more beneficial and cost-effective.

Another factor of great importance is the role of the instructor in the training system.

The built-in flexibility, such as the use of a sound generator to make the training environment as real as the engine room environment, gives the training programme a valuable contribution to the trainees. Nevertheless, a diesel room simulation training programme cannot completely be a substitute for the training on board ships. They must be complementary.

5.2 - RECOMMENDATIONS:

In using simulators for training of maritime personnel, the following recommendations can be made:

1. Simulators are a very powerful and cost-effective tool for the training of maritime personnel. Whether the students are marine engineers, ship masters, pilots, officers, coaster personnel or tug masters, their skills can be improved through simulator training.
2. To establish the objectives and contents of a training programme for a specific group, close cooperation between shipping companies and the administration of the Academy is necessary. Detailed discussions with the client will usually result in a balanced programme.
3. Training courses should be supported by lectures on special subjects. These lectures will enforce the simulator training exercises.
4. Training exercises should be executed according to the

briefing-exercise-debriefing principle.

To streamline the National Education and Training of Marine Engineers, it is necessary that the Academy must be the source of knowledge on marine engineering training and education.

The Academy, therefore, should start to offer a variety of courses under the supervision of the Ministry of Defense and in collaboration with the Ministry of Education to serve and safeguard the national and regional maritime interests.

The courses should have particular relevance to the maritime industry and also cover all the disciplines of marine engineer education and training.

In the same context, it should be emphasized that there must be some sort of collaboration between the Abidjan Academy and other universities in the world which conduct marine engineering education and training. In this regard, some suitable affiliation with the World Maritime University, Malmo, Sweden, the centre of international maritime education and training in maritime affairs, to serve national and regional maritime interest, is highly recommended.

APPENDIX A

MARITIME TRAINING COURSES IN THE FEDERAL REPUBLIC OF GERMANY

GENERAL TRAINING SCHEME
FOR ENGINEER LICENCES AND SHIP'S ELECTRICAL TECHNICIANS

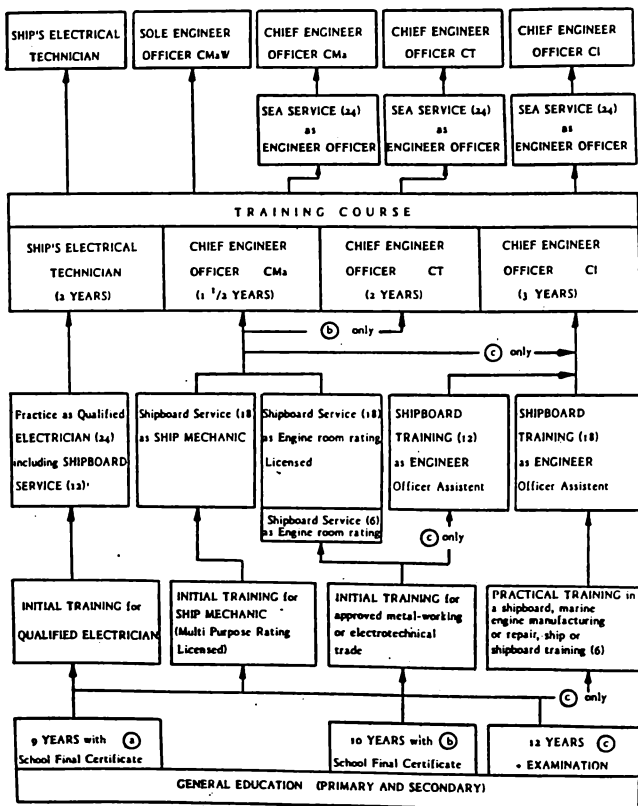

Remarks

Analogical Scheme for Nautical and Fishery Licences

MARITIME TRAINING COURSES IN THE FEDERAL REPUBLIC OF GERMANY

Course Title	MASTER AG
Certificate/Degree Obtained	DECK OFFICER AGW/ Polytechnic Degree in Nautical Science
Qualification	foreign going trade (unlimited tonnage)
Course Duration	3 years
Max. No. of Students/Participants	no restriction
Starting Date/Frequency	twice a year; details on demand
Foreign Students/Participants	admitted
Course Language	German
Fees	none

Minimum Entry Requirements:

- 1) School final certificate (with examination) after 12 years of primary and secondary education.
- 2.1) Successful initial training for ship mechanic¹⁾ or able-bodied seaman and 18 months shipboard service as ship mechanic, respectively able-bodied seaman, or (instead of 18 months shipboard service) 12 months training as nautical officer assistant,
- or
- 2.2) 9 months shipboard training as nautical officer apprentice and 15 months shipboard training as nautical officer assistant.

COURSE CONTENTS:
Fundamental segment:
(1st section of studies)

- mathematics, physics, chemistry
- informatics (EDP)
- basic economics, basic law
- psychology/sociology
- shipbuilding, marine engineering
- communications
- medical training

Advanced segment:
(2nd section of studies)

- navigation, maritime law, seamanship/ship technology (including simulator training: radar + shiphandling)
- meteorology/oceanography
- maritime economics and shipping management
- automation
- personnel management
- nautical English
- passage planning and shipmaster's business

Remarks

- 1) "SHIP MECHANIC" - qualified rating for deck and engine room service (MPC)
- 2) The training regulations for initial training of ABLE-BODIED SEAMEN were cancelled, effective on July 31, 1986.

APPENDIX A

MARITIME TRAINING COURSES IN THE FEDERAL REPUBLIC OF GERMANY

Course Title	MASTER AM
Certificate/Degree Obtained	DECK OFFICER AMW/ State-examined Mariner
Qualification	foreign going trade (limited to 4000 grt)
Course Duration	2 years
Max. No. of Students/Participants	no restriction
Starting Date/Frequency	once or twice a year; details on demand
Foreign Students/Participants	admitted
Course Language	German
Fees	none

Minimum Entry Requirements:

- 1) School final certificate after 10 years of primary and secondary education.
- 2) Successful initial training for ship mechanic¹⁾ or able-bodied seaman²⁾ and 18 months shipboard service as ship mechanic respectively able-bodied seaman.

COURSE CONTENTS:

- mathematics, physics, chemistry
 - politics and shipping management
 - German language
 - English language
 - personnel and work management
 - navigation
 - seamanship
 - maritime law
 - meteorology/oceanography
 - marine engineering
 - communications
 - medical training
- including simulator training
(radar + shiphandling)

Remarks

- 1) "SHIP MECHANIC" - qualified rating for deck and engine room service (NPC)
- 2) The training regulations for initial training of ABLE-BODIED SEAMEN were cancelled, effective on July 31, 1986.

APPENDIX A

MARITIME TRAINING COURSES IN THE FEDERAL REPUBLIC OF GERMANY

Course Title	MASTER AK
Certificate/Degree Obtained	DECK OFFICER AKW
Qualification	near continental trade (limited to 1000 grt)
Course Duration	1 1/2 years
Max. No. of Students/Participants	no restrictions
Starting Date/Frequency	once or twice a year; details on demand
Foreign Students/Participants	admitted
Course Language	German
Fees	none

Minimum Entry Requirements:

- 1) School final certificate after 9 years of primary and secondary education.
- 2) Successful initial training for ship mechanic¹⁾ or able-bodied seaman²⁾ and 18 months shipboard service as ship mechanic respectively able-bodied seaman.

COURSE CONTENTS:

- mathematics, physics, chemistry
- politics and shipping management
- German language
- English language
- personnel and work management
- navigation
- seamanship including simulator training (radar + shiphandling)
- maritime law
- meteorology
- marine engineering
- communications
- medical training

- Remarks
- 1) "SHIP MECHANIC" - qualified rating for deck and engine room service (MPC)
 - 2) The training regulations for initial training of ABLE-BODIED SEAMEN were cancelled, effective on July 31, 1986.

APPENDIX A

MARITIME TRAINING COURSES IN THE FEDERAL REPUBLIC OF GERMANY	
Course Title	CHIEF ENGINEER OFFICER CI
Certificate/Degree Obtained	ENGINEER OFFICER CIW Polytechnic Degree in Marine engineering
Qualification	unlimited propulsion power (all trading areas)
Course Duration	3 years
Max. No. of Students/Participants	no restrictions
Starting Date/Frequency	once or twice a year, details on demand
Foreign Students/Participants	admitted
Course Language	German
Fees	none
Minimum Entry Requirements:	<p>1) School final certificate (with examination) after 12 years of primary and secondary education.</p> <p>2.1) Successful initial training for ship mechanic¹⁾ or another recognized metal working or electrical trainee occupation according to ship mechanic and 18 months shipboard service as ship mechanic respectively engine room rating licensed²⁾ or (instead of 18 months shipboard service) 12 months shipboard training as engineer officer assistant or</p> <p>2.2) 6 months basic training for a metal working occupation and 18 month shipboard training as engineer officer assistant.</p>
COURSE CONTENTS:	
Fundamental segment: (1st section of studies)	
- mathematics, physics, chemistry	- operating materials
- informatics (EDP)	- thermodynamics
- basic economics, basic law	- electrical engineering
- personnel and work management	- electronics
- technical English	- measurement engineering
- mechanics	- basic monitoring and control engineering
- material technology	- basic nuclear engineering
	- technical drawing
Advanced segment: (2nd section of studies)	
- engineering components	- electrical machinery and plants
- shipbuilding	- applied control engineering
- diesel engineering	- ship's auxiliaries and plants
- steam engineering	- maritime economics and shipping management
- machinery dynamics	
Remarks	<p>1) "SHIP MECHANIC" = qualified for deck and engine room service (NPC).</p> <p>2) "ENGINE ROOM RATING LICENSED" = qualified for engine room service after successful initial training for one of those metal working or electrical trainee occupations and 6 month qualifying shipboard service as engine room rating.</p>

MARITIME TRAINING COURSES IN THE FEDERAL REPUBLIC OF GERMANY	
Course Title	CHIEF ENGINEER OFFICER CM ₂
Certificate/Degree Obtained	ENGINEER OFFICER CM ₂ W
Qualification	up to 3000 kW propulsion power (all trading areas)
Course Duration	1 1/2 years
Max. No. of Students/Participants	no restrictions
Starting Date/Frequency	once or twice a year, details on demand
Foreign Students/Participants	admitted
Course Language	German
Fees	none
Minimum Entry Requirements:	<p>1) School final certificate after 9 years of primary and secondary education.</p> <p>2) Successful initial training for ship mechanic¹⁾ or another recognized metal working or electrical trainee occupation according to ship mechanic and 18 months shipboard service as ship mechanic respectively engine room rating licensed²⁾.</p>
COURSE CONTENTS:	<ul style="list-style-type: none"> - politics and shipping management - German language - mathematics - physics - thermodynamics - electrical engineering - mechanics - personnel and plant management - technical English - operating materials - diesel engineering - steam engineering - plant engineering - ship's automation - shipbuilding
Remarks	<p>1) "SHIP MECHANIC" = qualified for deck and engine room service (MPC).</p> <p>2) "ENGINE ROOM RATING LICENSED" = qualified for engine room service after successful initial training for one of those metal working or electrical trainee occupations and 6 month qualifying shipboard service as engine room rating.</p>

APPENDIX A

MARITIME TRAINING COURSES IN THE FEDERAL REPUBLIC OF GERMANY		
Course Title	ENGINEER OFFICER CNaut	Only for holders of a German Master's or Deck officer's Certificate
Certificate/Degree Obtained	ENGINEER OFFICER CNaut	
Qualification	up to 600 kW propulsion power with machinery approved for unattended operation, continental trade	
Course Duration	160 hours	
Max. No. of Students/Participants	no restrictions	
Starting Date/Frequency	details on demand	
Foreign Students/Participants	admitted	
Course Language	German	
Fees	none	
Minimum Entry Requirements:	1) 9 years of primary and secondary school education. 2) Holding a German Master's or Deck Officer's Certificate of Competency.	
COURSE CONTENTS: <ul style="list-style-type: none"> - plant management - operating materials - measurement and control engineering - electrical engineering - diesel engineering 		
Remarks		

MARITIME TRAINING COURSES IN THE FEDERAL REPUBLIC OF GERMANY

Course Title	CHIEF ENGINEER OFFICER CT
Certificate/Degree Obtained	ENGINEER OFFICER CTW State-examined Technician
Qualification	up to 8000 kW propulsion power (all trading areas)
Course Duration	2 years
Max. No. of Students/Participants	no restrictions
Starting Date/Frequency	once or twice a year, details on demand
Foreign Students/Participants	admitted
Course Language	German
Fees	none

- Minimum Entry Requirements:
- 1) School certificate after 10 years of primary and secondary education.
 - 2) Successful initial training for ship mechanic¹⁾ or another recognized trainee occupation according to ship mechanic and 18 month shipboard service as ship mechanic respectively engine room rating licensed²⁾.

COURSE CONTENTS:

- politics and shipping management
- German language
- English language
- mathematics
- physics
- thermodynamics
- electrical engineering
- mechanics
- engineering components
- operating materials
- material technology
- personnel and plant management
- diesel engineering
- steam engineering
- electrical machinery
- plant engineering
- ship's automation
- shipbuilding

- Remarks
- 1) "SHIP MECHANIC" = qualified for deck and engine room service (MPC).
 - 2) "ENGINE ROOM RATING LICENSED" = qualified for engine room service after successful initial training for one of those metal working or electrical trainee occupations and 6 month qualifying shipboard service as engine room rating.

MARITIME TRAINING COURSES IN THE FEDERAL REPUBLIC OF GERMANY	
Course Title	SHIP'S ELECTRICAL TECHNICIAN
Certificate/Degree Obtained	State-examined Technician
Qualification	unlimited
Course Duration	2 years
Max. No. of Students/Participants	no restrictions
Starting Date/Frequency	once a year, details on demand
Foreign Students/Participants	admitted
Course Language	German
Fees	none
Minimum Entry Requirements:	<ol style="list-style-type: none"> 1) School final certificate after 9 years of primary and secondary education. 2) Successful initial training for a recognized electrical trainee occupation and at least two years practical experience in an occupation in this field including at least one year shipboard service.
COURSE CONTENTS:	<ul style="list-style-type: none"> - German language - English language - political and economic sciences - mathematics - physics - chemistry and material technology - technical drawing - data processing - basic electrical engineering - measurement engineering - business management - ship's automation - ship's electrical machinery and plants - ship's auxiliaries - communication and navigation equipment engineering - basic electronics - electronic engineering
Remarks	

U. S. Merchant Marine Academy

ACADEMIC PROGRAMS

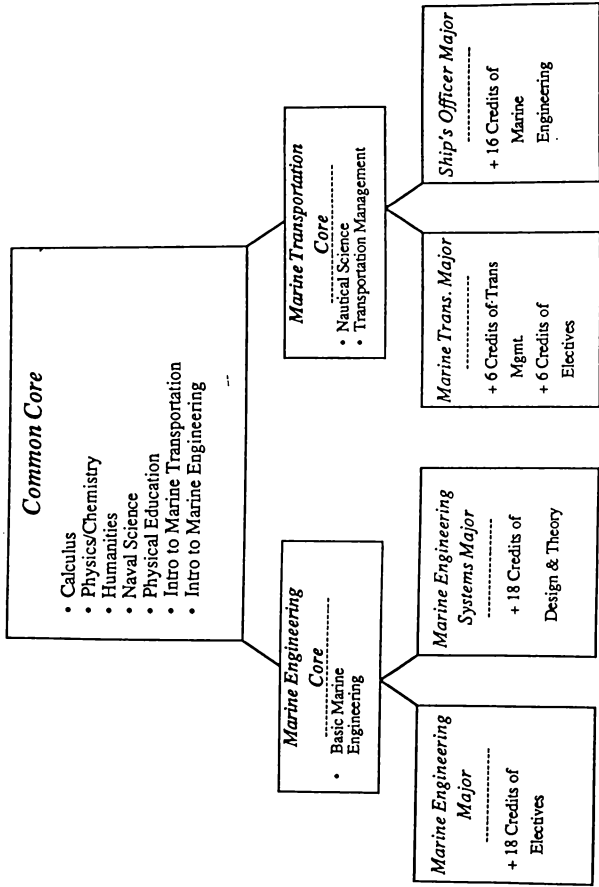

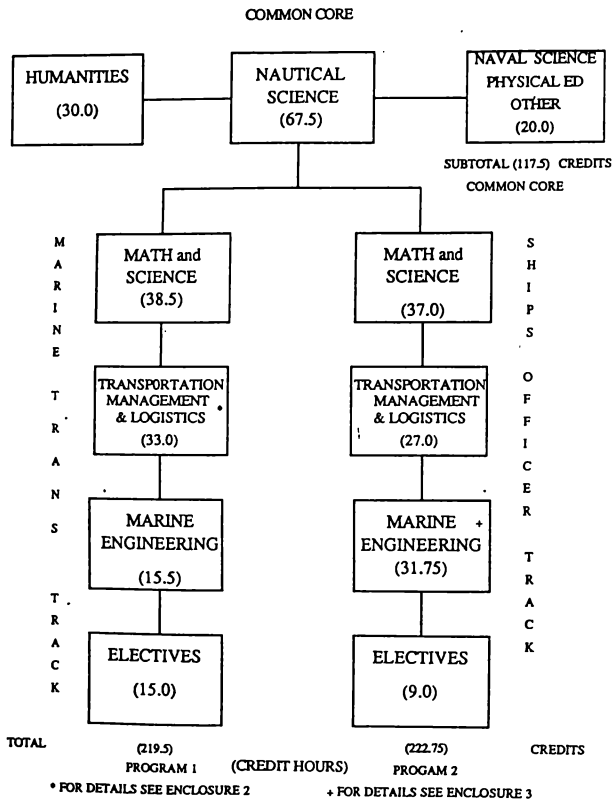
MARINE TRANSPORTATION PROGRAM

4th CLASS	C L * C R		C L * C R		C L * C R		C L * C R		
	18-B - 1975	18-C - 1976	18-D - 1977	18-E - 1978	18-F - 1979	18-G - 1980	18-H - 1981	18-I - 1982	
D110 MARINE SAFETY 1	2	1.0	E10A ENGR GRAPHICS 2	3	2	1.0	E10D ENGR GRAPHICS 3	2	1.0
D127 NAUTICAL SCIENCE 1	4	2	E10B ENGR GRAPHICS 1	3	3	1.0	E10E ENGR GRAPHICS 2	3	2
E102 ENGR GRAPHICS 1	3	1.0	E107 INTRO/MARINE SHOP 1	2	1.0	E108 INTRO/MARINE SHOP 2	2	1.0	
H101 ENGLISH 1	3	3.0	E110 INTRIC COMPUTER USAGE	1	1.0	E109 CALCUUS/GEOMETRY 3	4	4.0	
H102 ENGLISH 2	4	4.0	E112 ENGLISH 2	3	3.0	M143 GEN CHEMISTRY 1	3	2	
H121 PHYSICS 1	3	2	M103 CALCUUS/GEOMETRY 2	4	4.0	H101 FUND/NAVAL SCIENCE	3	3.0	
P101 PHY FIT AND SWIMMING	2	1.0	M122 PHYSICS 2	3	2	M103 SHIPS MEDICINE/CPR	2	1.0	
			P102 SELF DEFENSE	2	1.0				
1st Quarter									
18-B - 1975 2nd Quarter									
18-C - 1976 3rd Quarter									
18-D - 1977 4th Quarter									
18-E - 1978 5th Quarter									
18-F - 1979 6th Quarter									
18-G - 1980 7th Quarter									
18-H - 1981 8th Quarter									
18-I - 1982 9th Quarter									
18-J - 1983 10th Quarter									
18-K - 1984 11th Quarter									
18-L - 1985 12th Quarter									
18-M - 1986 13th Quarter									
18-N - 1987 14th Quarter									
18-O - 1988 15th Quarter									
18-P - 1989 16th Quarter									
18-Q - 1990 17th Quarter									
18-R - 1991 18th Quarter									
18-S - 1992 19th Quarter									
18-T - 1993 20th Quarter									
18-U - 1994 21st Quarter									
18-V - 1995 22nd Quarter									
18-W - 1996 23rd Quarter									
18-X - 1997 24th Quarter									
18-Y - 1998 25th Quarter									
18-Z - 1999 26th Quarter									
19-0 - 2000 27th Quarter									
19-1 - 2001 28th Quarter									
19-2 - 2002 29th Quarter									
19-3 - 2003 30th Quarter									
19-4 - 2004 31st Quarter									
19-5 - 2005 32nd Quarter									
19-6 - 2006 33rd Quarter									
19-7 - 2007 34th Quarter									
19-8 - 2008 35th Quarter									
19-9 - 2009 36th Quarter									
19-A - 2010 37th Quarter									
19-B - 2011 38th Quarter									
19-C - 2012 39th Quarter									
19-D - 2013 40th Quarter									
19-E - 2014 41st Quarter									
19-F - 2015 42nd Quarter									
19-G - 2016 43rd Quarter									
19-H - 2017 44th Quarter									
19-I - 2018 45th Quarter									
19-J - 2019 46th Quarter									
19-K - 2020 47th Quarter									
19-L - 2021 48th Quarter									
19-M - 2022 49th Quarter									
19-N - 2023 50th Quarter									
19-O - 2024 51st Quarter									
19-P - 2025 52nd Quarter									
19-Q - 2026 53rd Quarter									
19-R - 2027 54th Quarter									
19-S - 2028 55th Quarter									
19-T - 2029 56th Quarter									
19-U - 2030 57th Quarter									
19-V - 2031 58th Quarter									
19-W - 2032 59th Quarter									
19-X - 2033 60th Quarter									
19-Y - 2034 61st Quarter									
19-Z - 2035 62nd Quarter									
20-0 - 2036 63rd Quarter									
20-1 - 2037 64th Quarter									
20-2 - 2038 65th Quarter									
20-3 - 2039 66th Quarter									
20-4 - 2040 67th Quarter									
20-5 - 2041 68th Quarter									
20-6 - 2042 69th Quarter									
20-7 - 2043 70th Quarter									
20-8 - 2044 71st Quarter									
20-9 - 2045 72nd Quarter									
20-A - 2046 73rd Quarter									
20-B - 2047 74th Quarter									
20-C - 2048 75th Quarter									
20-D - 2049 76th Quarter									
20-E - 2050 77th Quarter									
20-F - 2051 78th Quarter									
20-G - 2052 79th Quarter									
20-H - 2053 80th Quarter									
20-I - 2054 81st Quarter									
20-J - 2055 82nd Quarter									
20-K - 2056 83rd Quarter									
20-L - 2057 84th Quarter									
20-M - 2058 85th Quarter									
20-N - 2059 86th Quarter									
20-O - 2060 87th Quarter									
20-P - 2061 88th Quarter									
20-Q - 2062 89th Quarter									
20-R - 2063 90th Quarter									
20-S - 2064 91st Quarter									
20-T - 2065 92nd Quarter									
20-U - 2066 93rd Quarter									
20-V - 2067 94th Quarter									
20-W - 2068 95th Quarter									
20-X - 2069 96th Quarter									
20-Y - 2070 97th Quarter									
20-Z - 2071 98th Quarter									
21-0 - 2072 99th Quarter									
21-1 - 2073 100th Quarter									

KEY: C-Conference/Lecture (Contact Hour); L-Lab (Contact Hours); *Lab every other week; CB-Credit Hours.
 *Lab every fourth week

Marine Engineering and Marine Engineering Systems Curricula

Third Class (Sophomore Year)

Introduction to Linear Differential Equations
 Physics III, IV
 Safety of Life at Sea I
 Introduction to Computer Engineering
 Introduction to Materials Engineering
 Engineering Mechanics I, II
 Thermodynamics I
 Economics I, II
 Naval Weapon Systems

Second Class (Junior Year)

Strength of Materials
 Principles of Naval Architecture
 Fluid Mechanics I
 Thermodynamics II, III
 Electric Circuits I, II
 History I
 Managerial Process
 Naval Operations I
 Physical Education
 Elective or

For Marine Engineering Systems:
 Differential Equations I

First Class (Senior Year)

For Marine Engineering:
 Marine Refrigeration
 Alternating-Current Machinery

Electronics I
 Marine Engineering I, II, III
 Internal Combustion Engines I, II
 History II, III
 Marine Transportation
 Naval Operations II
 Physical Education
 Option:
 Humanities Sequence or Comparative Culture Sequence
 Electives

For Marine Engineering Systems:

Fundamentals of Engineering Design
 Machine Design I
 Basic Ship Design
 Marine Refrigeration
 Alternating-Current Machinery
 Electronics I
 Marine Engineering I, II, III
 Internal Combustion Engines, I, II
 Thermal Systems Analysis
 Automatic Control Systems I
 Elective
 Marine Transportation
 Naval Operations II
 Physical Education
 History II, III
 Option:
 Humanities Sequence or Comparative Culture Sequence

Dual License Curriculum

Third Class (Sophomore Year)

Metal Joining Processes I
 Introduction to Computer Engineering
 Engineering Mechanics I, II
 Thermodynamics I
 Business/Maritime Law
 Economics I, II
 Introduction to Linear Differential Eq
 Physics III, IV
 Naval Weapons Systems

Second Class (Junior Year)

Marine Electronics I
 Marine Materials Handling II
 Seamanship I
 Meteorology

Navigation I

Strength of Materials
 Principles of Naval Architecture
 Fluid Mechanics I
 Thermodynamics II, III
 Electric Circuits I, II
 Physical Education

First Class (Senior Year)

Alternating-Current Machinery
 Marine Refrigeration
 Marine Engineering I, II, III
 Internal Combustion Engines I, II
 History I, II, III
 Humanities IV
 Marine Transportation
 Managerial Process
 Marine Insurance
 Marine Materials Handling III
 Marine Safety II, III
 Communications
 Seamanship II
 Navigation II
 Marine Electronics III, IV
 Naval Operations I, II
 Physical Education

**Marine Transportation majors only*

***Marine Engineering and Marine Engineering*

****Marine Engineering, Marine Engineering Sys*

*****Dual License majors*

******Dual License majors only*

**The curriculum is subject to change.*

Four-Year Program of Study

First Year (Fourth Class) Curriculum

First Quarter

Calculus and Analytic Geometry I
 Chemistry I
 English I
 Engineering Graphics I
 Marine Safety I
 Nautical Science I
 Physical Education

Second Quarter

Calculus and Analytic Geometry II
 Chemistry II
 English II
 Engineering Graphics II
 Marine Engineering I
 Engineering Shop I
 Physical Education

Third Quarter

Calculus and Analytic Geometry III
 Physics I
 Nautical Science II*
 Engineering Graphics III***
 Marine Engineering II***
 Engineering Shop II***
 Naval Science Fundamentals
 Physical Education
 Marine Transportation I*

Fourth Quarter

Calculus and Analytic Geometry IV
 Physics II
 Nautical Science III*
 Safety of Life at Sea I
 Nautical Science IV****
 Engineering Graphics IV**
 Electrical Engineering ***
 Metal Cutting Processes I***
 Metal Joining Processes I**
 English III
 Physical Education

Marine Transportation Curriculum

Third Class (Sophomore Year)

Physics III, IV
 Safety of Life at Sea I
 Engineering Science
 Statistics
 Introduction to Computer Engineering
 History I
 Economics I, II
 Meteorology
 Managerial Process
 Naval Weapons Systems
 Physical Education

Second Class (Junior Year)

Marine Materials Handling I, II
 Marine Electronics I
 Seamanship I
 Navigation I
 Accounting for Management
 History II, III
 Business/Maritime Law
 Naval Operations I
 Physical Education
 Elective

First Class (Senior Year)

Bridge Simulator Training
 Advanced Cargo Stowage and Ship Stability
 Marine Safety II, III
 Seamanship II
 Navigation II
 Marine Electronics III, IV
 Principles of Naval Architecture
 Marine Transportation II
 Marine Insurance
 Naval Operations II
 Maritime Labor Relations
 License Seminar
 Physical Education
 Option:

 Humanities Sequence or Comparative Culture
 Sequence or Foreign Language Sequence
 Electives

BIBLIOGRAPHY

- Maritime Training Forum Europe '89, Amsterdam, June 1989.
- Education & Regional Development, General Report Vol.1 Organization for Economic, Co-operation and Development, Paris 1979.
- Documents of Academy of Maritime Science and Technology, Abidjan, COTE D'IVOIRE.
- International Convention on Standards of Training, Certification and Watchkeeping for Seafarers, 1978, of the International Maritime Organization.
- IMO's Technical Assistance Programme.
- First International Conference on Marine Simulation, 1978. MARSIM 78. The College of Nautical Studies, Southampton. 5-8 September 1978.
- Proceedings of the Second International Conference on Marine Simulation, June 1-5 , 1981. Kings Point, N.Y, U.S.A.
- Conference on: Education and Training for Seafarers. What policy for the 1990's. 9-10 February 1984. Institute of Marine Engineers, London.

- Education in Sub-Saharan Africa, a World Bank Policy Study. Second printing, June 1988. The World Bank, Washington, D.C.

- Proceedings of the Third International Conference on Maritime Simulation 1984. MARSIM 84. Rotterdam, the Netherlands, 19-22 June 1984.

- Southampton Institute of Higher Education, the College of Maritime Studies. Prospectus, 1990.

- The Maritime Training System at Technical Schools and Polytechnics of the F.R.G., Bremen, 1986. (a booklet of the Bremen Institute).

- The United States Merchant Marine Academy Bulletin. Kings Point, New York, 1990.

- Maritime Education and Training in France, the State Ministry of the Sea, Paris 1987, (a booklet).

- State University of New York, Maritime College. Prospectus 1989-1990.

- International Conference on Simulators 26-30 September, 1983. The University of Sussex, Brighton, U.K.