

ANDREWS UNIVERSITY
HESHBON EXPEDITION
THE FIFTH CAMPAIGN AT TELL HESBÂN (1976)
A Preliminary Report

ROGER S. BORAAS
Upsala College
East Orange, New Jersey

LAWRENCE T. GERATY
Andrews University
Berrien Springs, Michigan

Tell Heshbân, a site some 25 road kilometers southwest of Amman that has been traditionally identified with Biblical Heshbon and the Greco-Roman Esbus, was excavated in a fifth and presumably final campaign from June 15 to August 11, 1976.¹ Heshbon's history as derived from the literary sources,² and the results of the previous four campaigns of 1968, 1971, 1973, and 1974, have already been covered in previous preliminary reports.³

¹ Brief reports of the 1976 season by L. T. Geraty appeared in *ASOR Newsletter* No. 8 (Jan., 1977): 1-15, and *ADAJ* 21 (1976): 41-53. One submitted to *RB* has not yet been published.

² W. Vyhmeister, *AUSS* 6 (1968): 158-177.

³ For the 1968 season, see R. S. Boraas and S. H. Horn, *et al.*, *Heshbon 1968* (*AUSS* 7 [1969]: 97-239), *AUM*, Vol. 2, 1969; Horn, *ADAJ* 12-13 (1967-68): 51-52; Horn, *ASOR Newsletter* No. 3 (1968-69): 1-5; Horn, *BA* 32 (1969): 26-41; Horn, *RB* 76 (1969): 395-398; E. N. Lugenbeal and J. A. Sauer, "Seventh-Sixth Century B.C. Pottery from Area B at Heshbon," *AUSS* 10 (1972): 21-69; A. Terian, "Coins from the 1968 Excavations at Heshbon," *AUSS* 9 (1971): 147-160.

For the 1971 season, see R. S. Boraas and S. H. Horn, *et al.*, *Heshbon 1971* (*AUSS* 11 [1973]: 1-144), *AUM*, Vol. 6, 1973; Horn, *ADAJ* 17 (1972): 15-22; Horn, *ASOR Newsletter* No. 4 (1971-72): 1-4; Horn, *RB* 79 (1972): 422-426; R. G. Bullard, "Geological Study of the Heshbon Area," *AUSS* 10 (1972): 129-141; J. A. Sauer, *Heshbon Pottery 1971* (*AUM*, Vol. 7, 1973); A. Terian, "Coins from the 1971 Excavations at Heshbon," *AUSS* 12 (1974): 35-46.

For the 1973 season, see R. S. Boraas and S. H. Horn, *et al.*, *Heshbon 1973* (*AUSS* 13 [1975]: 101-247), *AUM*, Vol. 8, 1975; Boraas, *PEQ* 106 (1974): 5-6; Horn, *ADAJ* 19 (1974): 151-156; Horn, *ASOR Newsletter* No. 2 (1973-74): 1-4; Horn, *RB* 82 (1975): 100-105; F. M. Cross, "Ammonite Ostraca from Heshbon: Heshbon Ostraca IV-VIII," *AUSS* 13 (1975): 1-20; B. Van Elderen, "A Greek Ostracon from Heshbon: Heshbon Ostracon IX," *AUSS* 13 (1975): 21-22; A. Terian, "Coins from the 1973 and 1974 Excavations at Heshbon," *AUSS* 14 (1976): 133-136.

For the 1974 season, see R. S. Boraas and L. T. Geraty, *et al.*, *Heshbon*

This article is intended as an introduction to a full preliminary report in which field supervisors not only give for their respective Area the results of the 1976 season in relation to tentative site-wide strata (designated by Roman numerals) but also incorporate their interpretation of all previously-excavated relevant loci from their respective Area for the preceding four seasons. Thus, in large measure, this last preliminary report can serve as the expedition's final report until those volumes appear.⁴

Sponsorship

Again in 1976 the major sponsor of the expedition in terms of personnel, direction, and financial support, was Andrews University,⁵ in close cooperation with the American Schools of Oriental Research's American Center of Oriental Research (ACOR) in Amman and the Department of Antiquities of Jordan. ACOR, through its Director, James A. Sauer, put its personnel, tools, and excavation equipment at the disposal of the expedition,⁶ and the Department of Antiquities, through its Director-General, Yacoub Oweis, and his associate, Yousef Alami, issued the excavation and survey permit, loaned personnel and certain pieces of equipment and provided assistance and courtesies in numerous

1974 (AUSS 14 [1976]: 1-216), AUM, Vol. 9, 1976; Geraty, ADAJ 20 (1975): 47-56; Geraty, ASOR Newsletter No. 5 (Nov., 1974): 1-8; Geraty, RB 82 (1975): 576-586; Ø. S. LaBianca, "Pertinence and Procedures for Knowing Bones," ASOR Newsletter No. 1 (July, 1975): 1-6.

⁴ The authors wish to acknowledge Julia Neuffer's extensive editorial help with many of the contributions that make up this preliminary report. While the preliminary report is diachronic by Area, the final report (whose preparation is underway) will of course have the advantage of being diachronic site-wide, by archaeological strata and historical periods.

⁵ It is a pleasure for the Director to publicly acknowledge the consistent encouragement and tangible support of Andrews University through the good offices of Presidents Richard Hammill and J. G. Smoot, Vice President V. E. Garber, Seminary Deans S. H. Horn and T. H. Blincoe, College Dean D. L. Ford, and Controller/Treasurer K. E. Hill.

⁶ During July 23-27, the expedition welcomed and benefited from the visit of three key ASOR officials: Philip J. King, soon to become President; Edward F. Campbell, Jr., Second Vice-president (for Archaeological Standards and Evaluation); and Melvin K. Lyons, Medical Director.

ways. Other dignitaries to whom the expedition owes a special debt of gratitude include H.R.H. Crown Prince Hassan and H.R.H. Crown Princess Tharwat, Prince Raad Zeid Hussein and Princess Majda Raad, Minister of Tourism and Antiquities Ghaleb Z. Barakat, U.S. Ambassador Thomas R. Pickering, Meteorological Department Director-General Ghazi el-Rifai, the Nabulsi family, and Elizabeth Aimé.

Other institutional sponsors who provided both personnel and generous financial support included Calvin Theological Seminary (Grand Rapids, Michigan), Covenant Theological Seminary (St. Louis, Missouri), Winebrenner Theological Seminary (Findlay, Ohio), Earthwatch (a national effort conceived by the Center for Field Research in Belmont, Massachusetts, to mobilize citizens of all ages in basic field research expeditions), the Kyle-Kelso Archaeological Fund (Holland, Michigan), and the Friends of Archaeology (Riverside, California). Worthington Foods Division of Miles Laboratories, Inc., donated the staff's textured protein requirements for the season.⁷

Major individual sponsorship came from Dr. and Mr. Charles L. Anderson, Mrs. Ruth Kaune Baucom, Eleanor and William Berecz, Jr., Wilber A. Bishop, Sr., Dr. and Mrs. Bernard Brandstater, Dr. and Mrs. Bruce Branson, Dr. Irvin N. Kuhn, Dr. and Mrs. John Wm. Schnepper, Walter E. Sooy, and John H. Weidner. Numerous private donors provided lesser support.

The expedition tenders its special thanks to all the above institutions and individuals for their generous support which made the fifth season of excavations at Tell Heshbân possible.

Organization

For the first time, the expedition's headquarters was located nearer Heshbân, in Madaba, at the Elementary Girl's School of the United Nations Relief and Works Agency for Palestine

⁷ SAS and Alia Airlines provided complimentary transportation, thanks to the efforts of Nabil Razzouk, Kenneth Fenski, and Iyyad Khalidi.

Refugees.⁸ The facilities there served admirably to house the 100-member staff and were adequate for makeshift bone and geology laboratories, a drafting room, a darkroom, and rooms for the processing of pottery, glass, and small finds. The only recurring problem was lack of adequate water, but the staff learned to take this in stride. The daily program was similar to that already described for the 1968 campaign.

The fulltime resident staff consisted of 13 Jordanians (mostly from the Department of Antiquities and the University of Jordan) and 83 foreigners (mostly professors and graduate students) from the United States, Canada, Australia, Norway, West Germany, Finland, Switzerland, Peru, and Taiwan. Another 11 volunteers were present at various times during the season.

The staff was composed of three groups. The Advisory Group was headed by Siegfried H. Horn of Andrews University who initiated the excavations in 1968 and directed them through the first three seasons, and James A. Sauer, ACOR Director, who gave unselfishly of his time and energy both before and after the excavation season. Other members of this group who aided immeasurably in the smooth running of the organization included the official representative from the Department of Antiquities, Mahmoud Rusan (who outdid himself in service to the expedition and its members in countless ways), Omar Yunis, Arif Abul-Ghannim, and Foreman Muhammad Murshed Khadija who was directly responsible for the oversight of about 140 local workmen, including Khamis, a "Jericho technical man."

Continuity in the 1976 Excavation Group was evidenced by the fact that 31 of these individuals (more than a third of those who worked fulltime) had already served on the Heshbon team

⁸ Arrangements for use of the facilities were made through the courtesy of John W. Tanner, Director of UNRWA Affairs, Jordan, and his associates, in cooperation with James A. Sauer, ACOR Director. A special word of thanks for services rendered at that time goes to Jordanian Army Col. Nurdin Sadiq, Madaba Area Governor M. O. Jariry, Madaba District Inspector of Antiquities Mahmoud Rusan, and Mr. and Mrs. Issa Hazboun of the Madaba Government Rest House.

during a previous season.⁹ Continuing in key oversight responsibility were Lawrence T. Geraty of Andrews University, Director; Roger S. Boraas of Upsala College, Chief Stratigrapher and Coordinator of Specialists; and James A. Sauer of ACOR, Chief Ceramic Typologist. In the following listing, each excavation group member is mentioned in connection with his or her primary assignment, though in certain cases there were shifts which took place during the season (these are noted in parenthesis). Fulltime Earthwatch volunteers are starred (*).

Area A on the summit of the acropolis was again supervised by Bastiaan Van Elderen of Calvin Theological Seminary. Of the nine Squares previously opened, only Squares 6, 8, and 9 were worked in 1976, and Squares 10 and 11 were begun. Square supervisors were Kim Baker, Douglas Clark, Julia Neuffer, Mahmoud Rusan (Area G), Oscar Schultz, Jr., and Margit Süring (Pottery Registration).

Area B and Square D.4 on a level shelf to the southwest of the acropolis summit was supervised by Larry G. Herr of Harvard University in consultation with James A. Sauer (Area B Supervisor since 1971) who continued to work on his pottery report in camp. Of the eight Squares (including D.4) previously opened, only Squares 2, 4, 7, and D.4 were continued in 1976. Square supervisors were Donald Casebolt, Ronald Geraty, Kenneth Knutsen (Area G), Larry Mitchel (Area G), Peter Soderman (Area F), *Marilyn Stickle (Area F), and Bjornar Storfjell (Area F).

Area C on the *tell's* western slope was expanded eastward to connect up with Area A, so for the first time its supervision was divided up. Continuing as supervisor of the western sector of Area C (Squares 1, 2, 3, 5, and 7) was W. Harold Mare of Covenant Theological Seminary. Of these five previously-opened Squares, only Squares 1, 5, and 7 were worked in 1976. Square

⁹ Another 18 individuals had worked at other sites, so all together more than half the group had excavation experience before the thorough week's pre-dig orientation at Tell Heshbón.

supervisors were *Esther Benton (Bone Lab), Jelmer Groenewold, Jennifer Groot, Myra Mare, Nabil Qadi, Douglas Robertson, Saleh Sari, and Timothy Schultz (Area G).

Area C's eastern sector (Squares 4, 6, 8, 9, and 10) was for the first time supervised by S. Thomas Parker of the University of California at Los Angeles. Of these five Squares, only 4, 6, and 8 were previously opened. Squares 6 and 8 were continued and Squares 9 and 10 were excavated for the first time in 1976. Square supervisors were Miriam Boraas, John Coughenour, Patricia Crawford, Carol Moerman, Michael Toplyn, William Urbrock, Nathaniel Yen, Omar Yunis, and Mary Witt.

Area D, connecting Areas A and B, was again supervised by Larry G. Herr. Of the previously-opened five (excluding D.4) Squares, work was continued in only Squares 2 and 3. Square supervisors were Kerry Brandstater (Area G), Vincent Clark (Area C, eastern sector), and John Lawlor (Area G).

Area F.24-41—all new tombs and caves,¹⁰ on the east side of the Wadi el-Majarr to the west and southwest of the *tell*, and Area K.1, 2—new tombs on the east side of the Wadi el-Marbat due east of the *tell*, were supervised for the first time by John J. Davis of Grace Theological Seminary. His assistants were Sheila Geraty (Area G), Scott Longacre, *Frank Lounsberry, Patricia Schmidt, and Marilyn Tanis.

Area G was the collective designation for several scattered soundings in the vicinity of the *tell*. Squares G.1-10 were excavated in 1973 and 1974. Square G.4, a cave-cistern complex near the village south of the acropolis, was continued in 1976; probed for the first time were G.13 and 15 nearby—all supervised by Donald H. Wimmer of Seton Hall University. Robin M. Brown of the University of Michigan supervised G.11, 16, 17, and 18—all test trenches on the north and east slopes of the *tell* except for G.18 which was in the village to the south. B. Michael Blaine of Glendale, California, supervised sounding G.12 on the saddle

¹⁰ Area E.1-6 and Area F.1-23 were excavated between 1971-1974.

southwest of the acropolis, and John I. Lawlor of Baptist Bible College (Clark's Summit, Pennsylvania) supervised G.14, the remains of a Byzantine church due north of the acropolis. The initial Area G Square supervisors were *Raymond Bankes (Area F), Murray Moerman, and Sheri Paauw.

Remie and Mary Fenske were parttime volunteers from Amman who willingly fitted into various Areas as needed.

The regional archaeological survey continued under Robert D. Ibach, Jr., of Grace Theological Seminary, extending its coverage to the triangular region between the Amman-Na'ur Road and the Amman-Madaba Road. His assistants were Arif Abul-Ghannim and *Carl Wheat.

Surveying and architectural drafting were again in the charge of Bert DeVries of Calvin College; his assistants were Merling Alomía, Henry Kuhlman, David Piper, Daniel Salzmann, and Anita Van Elderen.

Paul H. Denton of Andrews University again supervised all photography; his assistants were Kaye Barton, Loren Calvert, Anna Eaton, Andrew Kramer, Scott Rolston, and Mitchell Tyner.

The zooarchaeology and ethnography team was again headed by Øystein S. LaBianca. His assistants were Pamela Butterworth, Mary Ann Casebolt, Adelma Downing, Theresa Fuentes, Samir Ghishan, Asta S. LaBianca, and Patricia Tyner. During portions of the season the team was joined by the following Earthwatch volunteers: Sissy May (June 20-July 9), Helen Shafer and Paul Vance (July 11-30). During a post season (August 8-27) "bone lab" headquartered at the Seventh-day Adventist Secondary School on Jebel Amman, Earthwatch volunteers Elizabeth Horner, Lori LaValley, Julia Middleton, and Merryanna Swartz assisted the LaBiancas, C.9 "test square" supervisors Crawford and Toplyn, and the following consultant specialists: Paul W. Perkins of the Institute for Informatics Research and Computer Design, and Joachim Boessneck and Angela von den Driesch of the Institut für Palaeoanatomie, Domestikationsforschung, und

Geschichte der Tiermedizin der Universität München.

Other specialists included Physical Anthropologists James H. Stirling of Loma Linda University, who was responsible for the human skeletal remains from the cemeteries, Robert M. Little of Berrien Springs, Michigan, who took care of the human skeletal remains from the *tell*, and Geologist P. Edgar Hare of the Carnegie Geophysical Institute whose assistant was Robin Cox.

Siegfried H. Horn again served also as object registrar assisted by Abraham Terian of Andrews University who promptly identified all coin finds. Hester Thomsen of Greater New York Academy was once again in charge of all pottery washing, drying, sorting, and registering; Diane Groenewold (Area A) assisted her.

The Support Group for the staff was headed by Robert A. Coughenour of Western Theological Seminary who served as director of education (coordinating orientation, lectures, and tours) in addition to his assignment in Area A. Ronald D. Geraty, camp physician, and Mary Ann Casebolt, camp nurse, demonstrated their importance to the team by the fact that despite the large staff and difficult conditions, there were no hospitalizations or serious illnesses or accidents during the two-month expedition. Lorrie Knutsen served as camp receptionist-secretary-storekeeper. Muhammad Adawi, ACOR's major-domo, was once again chief cook; his assistants were Ishaq Adawi, Issa Muhammad, Walid Hussein, and Azme Ahmad, with the parttime assistance of Will Kidwell on the *tell*. Joyce Rochat of Andrews University was a guest of the expedition while she interviewed Siegfried Horn for his biography.

*Aims*¹¹

The overall aim in the final season of the expedition's current work at Tell Heshbân was to complete the stratigraphic inquiry

¹¹ The aims were governed by the continuing strategy of cutting along the edges of a "quarter pie" slice of the main *tell*. Completion of this strategy required opening new Squares so as to link Areas C and A along the east-west axis, and the completion of excavation to bedrock in all Squares along the main axes. The excavation and recording methods were extensions of

in the series of Squares laid along the western portion of the east-west axis and along the southern portion of the north-south axis. The intent was to complete a stratigraphic cut from the west perimeter to the center of the acropolis and south to the edge of the *tell* proper. The purpose was to sample the stratigraphy in detail by means of a continuous section running from the center of the acropolis to two edges of the *tell*, each portion serving to check and correct the reading of the other. By such a bi-focal stratigraphic sample it was hoped to derive a reasonably certain sequence of occupation history for the main site.

Three remaining problems of architectural diagnosis also affected the aims of the season. Recognized in 1973 as requiring two additional seasons' work for proper analysis, the three items governed specific excavation plans. To locate the west edge of the Byzantine church on the acropolis had become more problematic with the decision of the Department of Antiquities to preserve the Islamic bath built above the ruined church at its western edges.¹² The procedure still available to us was the removal of the west balk of Squares A.5 and 6 in the hope that sufficient clues might be apparent in such limited space. To clarify the nature of the "defense" building on the west perimeter it was decided to expand the work in C.5 to the main axis balk (the south balk of C.5) though we knew it meant digging through several meters of Byzantine and Mamlūk dump before the build-

those employed in previous seasons (see *Heshbon 1968*, pp. 110-117) and specified in the manual of instruction prepared for the staff. In this report the Area is designated by a capital letter, the Square by an Arabic numeral preceded by a period, and the Locus by an Arabic numeral preceded by a colon. A.8 refers to Area A, Square 8, whereas D.4:23 would designate Area D, Square 4, Locus 23.

¹² The period divisions adopted for the expedition follow the pattern reported in Sauer, *Heshbon Pottery 1971*, pp. 1-7. This is adapted in the tentative stratigraphic chart for the correlation of site-wide work given below. All contributors were instructed to employ the tentative site-wide periodization in preparing reports for this issue, but participation has suffered some variation. The site-wide periodization employs Roman numerals for Stratum designations with names used for broader historical period identifications, as indicated in *Heshbon 1968*, pp. 114-115.

ing remains would be reached. The third problem was to try to settle the question whether the large installation on the south shelf was indeed a reservoir as designed, and to get any additional data helpful for a precise dating of its construction, use and abandonment.

While all these aims were focused on the main *tell* stratigraphy and architecture, the fact that this was to be the last season spurred several additional efforts in new as well as continuing directions of work.

Continuing work was done in the search for burials, specifically those of the Iron Age settlements. Evidence from Mt. Nebo affected the decision to pay special attention to various cave installations on all sides of the terrain surrounding the *tell*. Additional work was done by the regional survey crew to fill in zones of sparse coverage remaining from previous seasons, and to experiment with a grid-sampling approach to a major site, Jalūl. Additional work was undertaken to continue the froth-flotation sampling from three Squares on different portions of the site, to examine a sequence from ground-surface to bedrock in each case, and to allow comparative studies of such data from various portions of the site. Expansion of analyses was attempted in the study of animal bone material under the option of arrangements to bring a portable field terminal for the computerization of the data. Pollen and soil samples for geological analysis were extended and a geological map of the site was to be developed in some detail. Extensive exploration of the occupation history of subterranean features was continued in a cave complex (G.4) on the southwest arm of the *tell* base. The architect-survey staff worked to extend and complete the contour map development.

Among new efforts this season was an attempt at testing precisely the difference in results of data-retrieval by using our conventional methods in one half of a Square (C.9) while applying uniformly a medium screen sifting of all earth removed

from the other half of the Square. Ethnographic studies were extended through the cooperation of various local households and families of the present village population. In a series of Squares excavated as soundings on the north, east, and south sides of the *tell*, the effort was aimed to cross-check the accuracy of our reading of the stratigraphy on the main *tell* and to test the accuracy and adequacy of our site-wide stratigraphic analysis. It was hoped to provide evidence if auxiliary settlements were made in different periods than those evident on the central *tell*. For this purpose, Squares G.11 and 14 were opened on the north shelf and at the base of the *tell* on the north side respectively. Squares G.16 and 17 were opened near the base of the *tell* on the east, and Squares G.12, 13, 15, and 18 were dug on the south and southwest of the *tell*. By special arrangements with the Royal Weather Service, a set of weather observation and recording instruments was installed on the northeast corner of the acropolis to allow a one-month sequence of readings to allow comparisons with the local readings at regular government observation stations. Finally, the completion of the stratigraphic cut from the west perimeter to the acropolis, mentioned above, involved opening a new sub-segment of Area C comprising three Squares (C.8, 9, and 10) and an extension westward of Area A (A.11).

*Accomplishments*¹³

As for the overall aim of completing excavation to bedrock in the main stratigraphic cut on the site, the accomplishment was nearly complete. In only one Square (C.10) along the entire sequence abutting the main east-west and north-south axes did we not reach bedrock by the last day of the season. It can also be reported that the two segments of this stratigraphic sampling

¹³ Since the publication plan for the final preliminary report called for writers to account for the entire sequence of loci excavated in their assigned Areas and to interpret the results through the site-wide periodization chart given below, this introductory summary of accomplishments makes no pretense to deal comprehensively with all new material. The summary will focus on matters most directly relating to the stated aims of the season's work.

indicated a consistent pattern of occupation history from Iron I_A through Mamlūk times. It can further be reported that the data from all the soundings around the perimeter of the *tell* show the same pattern of occupation history. No new periods were evident, but several new architectural features were encountered in these soundings. Primary in this regard was evidence of two additional Byzantine period churches. G.17, on the northeast perimeter of the base of the *tell*, was initiated on the basis of a local land-owner's report that mosaic material had appeared during his house construction. The small sounding did expose a mosaic medallion of the sort found in an aisle of a church floor of the Byzantine period. Indications were sufficiently substantial to draw preliminary plans for further excavation by the Department of Antiquities. The placement of sounding G.14 on the north perimeter of the base of the *tell* was governed by ground surface indications of architectural fragments, some apparently *in situ*, suggesting some building using classical design features. Excavation indicated an eastern apsidal feature with at least two stages of mosaic floor development, supported by surrounding architectural clues indicating a third Byzantine period church as likely. Currently plans are underway for further exploration of that feature by an American archaeological team.

As for the three major architectural problems remaining from the previous seasons' works, success was somewhat mixed. Most clearly settled was the matter of the "reservoir" on the south shelf of the site. Excavation in Area B showed a clear sealed join of the cement layered floor first encountered in B.1 to the layered plastered side exposed in B.2 and 4. Tracking the east wall of the installation to both its northeast and southeast corners and the observation of the directions and angles of the tip-lines in the fill after it was abandoned allowed the conclusion that its shape was probably square. Its capacity, estimated on the dimensions exposed, was probably ca. 1,200,000 liters. As such it is the largest such installation from the Iron II period thus far found on the

east bank of the Jordan. The mode of its destruction was probably weakness due to nearby caves or the trauma of earthquake. Collapse was most evident adjacent to a cave very close to the southeast corner.

Concerning the west perimeter "defense" building, the successful removal of large dump accumulations still covering the installation in the south half of Square C.5 indicated an Early Roman tower with internal modifications built during the Byzantine occupation. Most problematic for its defensive function was the location of the small doorway and aisle leading down to the west from the west exterior of the building. It suggests a building convertible from peacetime use for guard duty or toll collection to defense use in wartime. Presumably the west doorway might have been blocked rather quickly if wartime conditions had threatened. The substantial nature of the walls and the founding of the building on bedrock support the theory of a defensive use as the intent of the structure. Additional exploration of the Iron II "defense" wall in C.7 brought to view a Roman and Byzantine modification of the structure to allow use of underground cave facilities, probably for domestic use.

The search for the west edge of the Byzantine basilica on the acropolis was limited to the removal of the west balks of Squares A.5 and 6. That balk removal did expose a west wall for the nave of the later of the two main phases of the building, but the remains of the Islamic bath prevented clear exposure of any entrance facilities or the pursuit of the location of the western edge of the earliest phase of the building in this operation.

In other efforts, the location of Iron Age burials still eluded us. The exploration did locate and excavate several additional tombs of the Roman and Byzantine periods, some utilization of caves for both living and burial quarters, but no clear Iron Age burial evidence was found. With the exception of a zone in which military security limited the access of our team, the 10 km.-radius regional survey was completed. The location and recording of 30 additional occupation sites bring this archeological survey to

a responsible degree of completion. The results of the experimental grid-survey treatment of a major site were also gratifying. The combination of froth-flotation sampling and regular soil sampling has now put at the disposal of the palynologists and seed analysts a complete sequence of the seed and pollen patterns in the ancient deposits from ground surface to bedrock. We anticipate additional analyses of shell and some micro-organism deposits from the same sample range. Given use of the three Squares, the overlapping and complementary nature of the stratigraphic sequence should allow comparative studies for every period in the occupation history of the site. It may serve in the future as a data base for comparative studies with other sites excavated in the country.

The expanded sampling of animal bone material was conducted in the field, and there were intense analytical studies of the previously gathered animal bone collection. However, difficulties prevented the arrival of the field computer terminal, so such analyses were recorded for subsequent processing. The recording of observations of the geology staff allowed the production of a detailed geological map of the site and its immediate environs. The weather station observations were similarly made for future analysis, and the report was submitted to the Royal Weather Service. The contour map extension and completion by the architect-survey staff was finished in addition to the routine production of floor-plans, elevations and sections of architecture exposed in the excavations.

The effort to test the relative results in different procedures of data retrieval from waste soil met with mixed results. The material was largely restricted to the Mamlūk period, so the question of adequate representation of the variety of materials involved must be held open. The primary benefit in the experimental retrieval technique applied seemed to be the quantity of small bone material recovered. Larger amounts of bird, fish, and small mammal bone evidence were recovered.

The collections of modern flora, ornithological observations,

and the ethnographic observations will supplement the comparative data for subsequent ecological analyses. In view of these expanded special efforts and results one ought not to understate the routine accomplishments of the ceramic analysis, numismatic studies, human skeletal classification and pathology identifications, or small find studies done in the field. These continued to add large quantities of information to previously processed materials. Especially impressive were a small carved plaque of "Prometheus Bound," an Umayyad coin with the figure of the caliph represented, a gold cameo earring, and ceramic refinements in several subdivisions of the various periods.

Of some gratification was the location of dump or erosion layers from the earliest period of occupation, Iron I_A, in new portions of Area C.1 and 5, as well as in D.4. While it was disappointing not to have more intact occupation remains recoverable, especially architectural fragments or buildings, these additional materials confirmed more fully the previous observation that the main *tell* was first occupied in that period.

Finally, it was an accomplishment of the architect-survey team that a general plan for the proposed tourist development of the site was produced. Suggestions for preservation and reconstruction of architecture and other features were supplemented by development of a tour route which would allow the visitor the fullest exposure to the various period evidences available. Suggested accommodations for traversing the site as well as for a local museum facility were described and accepted by the Department of Antiquities.

Tentative Periodization¹⁴

<i>Stratum</i>	<i>Period</i>	<i>Approximate Dates</i>
I	Late Ottoman/Modern	A.D. ca. 1870-

¹⁴ It became apparent as early as 1973 that the most helpful sector of the excavation to provide the skeleton of an overall stratigraphic sequence for the site would be Area B on the south shelf of the *tell*. It further became evident that the most helpful supplemental sector to Area B for the development of

Post II Gap	Ottoman	A.D. ca. 1456-1870
II	Late Mamlūk	A.D. ca. 1400-1456
III	Early Mamlūk	A.D. ca. 1260-1400
IV	Ayyūbid	A.D. ca. 1200-1260
V _A		A.D. ca. 969-1200 ¹⁵
V _B	'Abbāsīd	A.D. ca. 750-969
VI	Umayyad	A.D. ca. 661-750
VII	Late Byzantine-Pre-Umayyad	A.D. ca. 614-661
VIII	Early Byzantine IV- Late Byzantine III	A.D. ca. 450-614
IX	Early Byzantine III- Early Byzantine IV	A.D. ca. 400-450
X	Early Byzantine II	A.D. ca. 365-400
XI	Early Byzantine II	A.D. ca. 365 (earthquake)
XII	Early Byzantine I	A.D. ca. 350-365
XIII	Early Byzantine I	A.D. ca. 340-350
XIV	Early Byzantine I	A.D. ca. 324-340
XV	Late Roman II-IV	A.D. ca. 193-324
XVI	Late Roman I	A.D. ca. 135-193
XVII	Early Roman IV	A.D. ca. 70-135
XVIII	Early Roman II-III	ca. 31 B.C. - A.D. 70
XIX	Early Roman I	ca. 63-31 B.C.
XX	Late Hellenistic	ca. 198-63 B.C.
XXI	Early Hellenistic	ca. 250-198 B.C.
Post XXII Gap	Late Persian	ca. 500-250 B.C.
XXII	Iron II-Persian	ca. 850-500 B.C.
XXIII	Iron I _B -II _A	ca. 1100-850 B.C.
XXIV	Iron I _A	ca. 1200-1100 B.C.

Concluding Comment

It is apparent, we trust, that the effort at preliminary judgment such a sequence would be the contiguous Area D which extended up the south slope to the acropolis and its interior. From these observations, it was requested of the respective Area Supervisors, James Sauer and Larry Herr, that they work out a tentative framework of Strata and periods to test whether the remaining material from other Areas might fit or require modification of such a framework. This they did in mid-season, 1976, with the result that conversations became possible with the remaining staff to detect problems or necessary changes. Out of these conversations and subsequent discussions by the end of the season, the framework here provided was refined. It should be very clear that both the Strata sequence and the periodizations assigned are yet tentative and may well be subject to revision in the final publication. They are our best considered judgment at this stage of the studies.

¹⁵ Precise assignment to a period must await further analysis. Material in this category was previously published as 'Abbāsīd (Pit in B.5 as found in *Heshbon 1973*), but studies currently under way may require revising that judgment.

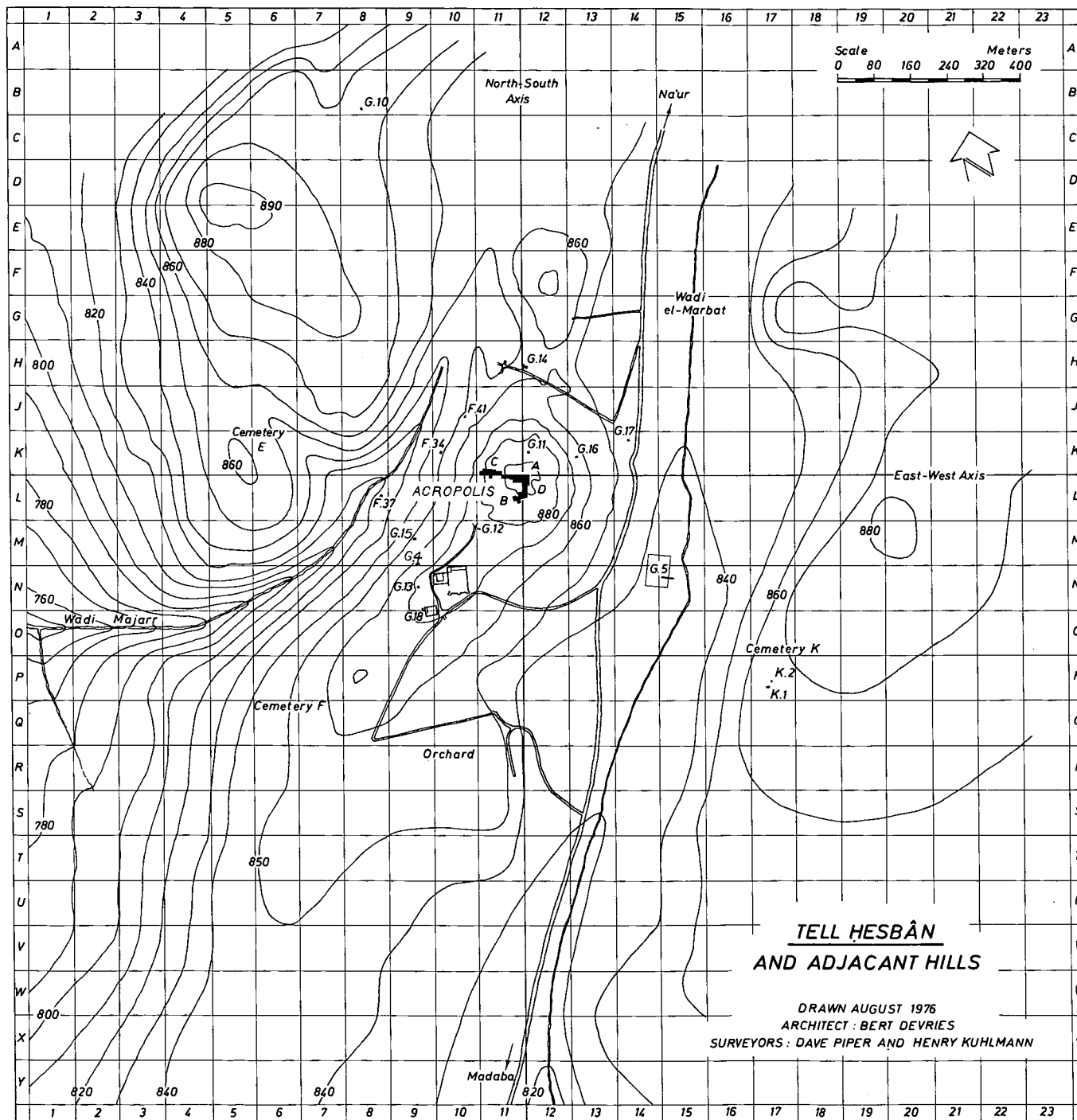

Fig. 1. Contour map of Tell Hesbân including Areas A-D on the acropolis, Cemeteries E and F to the west (the latter including caves as well as tombs), Cemetery K to the southeast, and Area G, soundings scattered around the flanks of the mound (only G.4, 11-18 having been excavated in 1976).

ments of such a site-wide synthesis has benefited from the contributions of many of the staff. As future work is assumed on the site, it is to be hoped that several of the tantalizing aspects of the occupation history which remain, either by the necessities imposed on this series of expeditions by external circumstances such as wars, or the fallible judgments made by the participants, will be illumined and resolved. It is to be wished that similar cooperation and good will as has attended these efforts in the past decade might enhance any such future labor. It is a debt we happily acknowledge to our village workers, government officials, and sponsors as this phase of operations is brought to a close.

AREA A*

BASTIAAN VAN ELDEREN

Calvin Theological Seminary
Grand Rapids, Michigan

The fifth season of excavation in Area A completed a stratigraphic section along the east-west axis joining Area A and Area C. Previously a similar section along the north-south axis had joined Area A and Area D. Work in Area A in 1976 concentrated on the western part of the acropolis in order to ascertain the stratigraphy and architectural remains of the Islamic bath, the west end of the Byzantine basilica, the Roman building, and pre-Roman installations. Two new Squares (A.10 and 11) were opened and further work (excavating to bedrock) was done in Squares 6 (west balk), 8, and 9. By the end of this season a complete occupational history of Area A had been recovered. The following description will delineate the various strata identified in Area A during the five seasons, with special emphasis on the Squares opened in 1976.

Since Squares 8 and 9 both contained extensive evidence from the Mamlūk period—portions of the bath complex (Square 8) and hallways and rooms (Square 9)—it was felt that excavating Square 10 west and south of these Squares would provide some materials to integrate the various architectural features. The main feature found in Square 10 was a large paved courtyard which linked the architecture of the two surrounding Squares. Since this pavement was intact, it was not possible to excavate deeper because the Department of Antiquities desired to preserve and restore the Islamic remains in this sector.

* *Editor's Note:* This brief report does not conform to the general format for Area reports primarily in that description and interpretation are mixed.

Square 11 was excavated directly west of Square 9 for two principal reasons. First, its north balk was on the east-west axis and therefore the Square became a link joining Areas A and C in completing the stratigraphic section along the east-west axis. Furthermore, the Square cut the western edge of the acropolis where it was presumed the defense wall of the acropolis would be located. Such a wall, partly visible before excavating, was fully exposed and its construction identified as Hellenistic. Surfaces and other features were identified with the various phases of the wall.

Strata II-III: Mamlūk (ca. A.D. 1260-1456)

The previous four seasons had yielded clear evidence of Mamlūk occupation of the acropolis. It is now possible to reconstruct the general architectural layout of the summit in this period. Buildings were constructed on the south, west, and north sides of the acropolis. This U-shaped complex formed a large open courtyard in the middle, which appeared to have been open on the east side. A drainage system in this courtyard, evident in the water channels in Squares 2 and 4 (A.2:4, 5, 6, 9, 10; A.4:4) drew off the rain water into a large cistern (A.2:11) located between the pillar bases 2 and 3 in the north row of the basilica of an earlier stratum.¹ Although no surface of this courtyard was intact, it lay almost directly above the mosaic floor of the last phase of the basilica.

The most intricate architecture of the Mamlūk period was the bath complex, first identified in 1973² and further excavated in 1974.³ In 1973 two water tanks, bathing room, and hallway were uncovered along with the furnace chamber for the heating of the bathing room and the larger water tank. In 1974 in Square 8 the lounging room and entrance hallway with the main entrance were

¹ *AUSS* 7 (1969): 146-148, 152.

² *AUSS* 13 (1975): 117-122.

³ *AUSS* 14 (1976): 18-20.

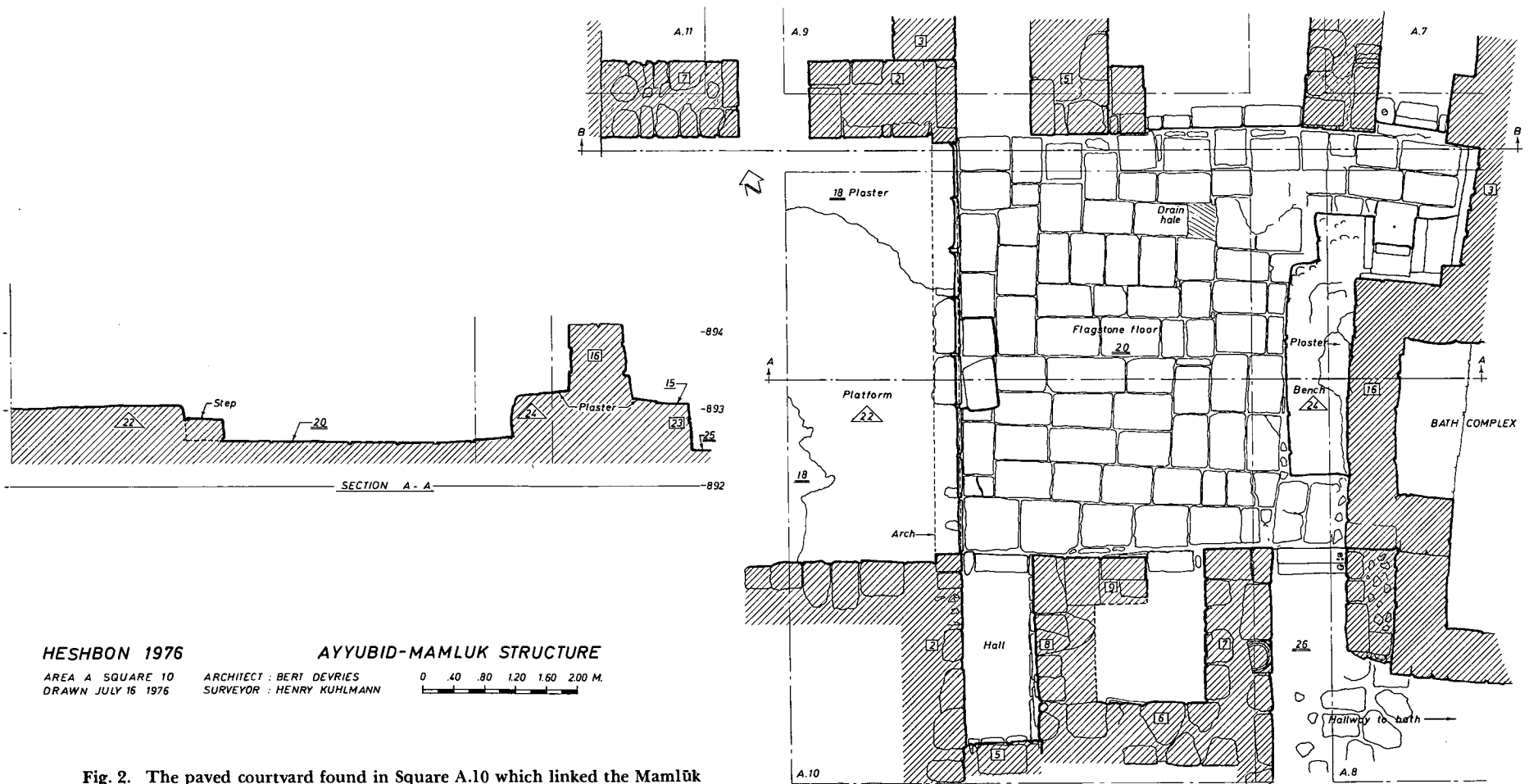
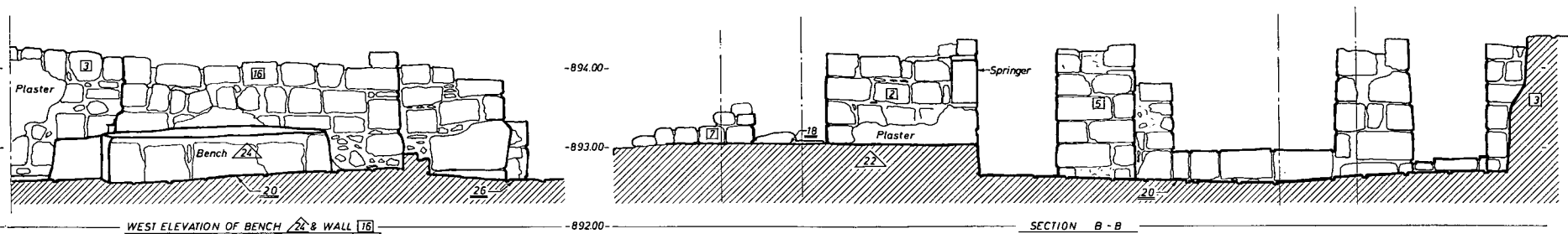

Fig. 2. The paved courtyard found in Square A.10 which linked the Mamlük Strata II-III architecture of the surrounding Squares (cf. pp. 19, 22).

HESHBON 1976

AYYUBID-MAMLUK STRUCTURE

AREA A SQUARE 10
DRAWN JULY 16 1976

ARCHITECT : BERT DEVRIES
SURVEYOR : HENRY KUHLMANN

0 40 80 120 160 200 M.

uncovered. Sizeable portions of the plaster on various walls of the complex were still preserved; the tile floor of the bathing room was intact for the most part; and the pavement stones in the hallways were still in position. Directly north of the heating chamber was a room which served as the furnace room. In 1971 in Square 6 directly east of the main entrance to the bath complex, a room contemporaneous with the complex was identified.⁴ The architecture consisted of walls and a platform made of large architectural members: bases, column sections, architraves. This room served as a porch or vestibule of the bath complex.

The west wall of the bath complex was a solid wall with no openings, windows, or doorways. This feature (with the entrance on the east side) sealed off the bath from both the drafts and the dust occasioned by the west winds that blow almost daily across the acropolis. Likewise, the afternoon sun was kept out—just as the buildings on the west side of the acropolis provided shade and protection from dust and wind for the large open court.

Excavation in Square 9 in 1974 exposed a north-south hallway with related rooms contemporaneous with the bath complex.⁵ The western wall of this set of Mamlūk rooms was the outer perimeter wall of the acropolis exposed in Square 11 in 1976. The upper two courses of this perimeter wall (A.11:23) were dated in the Mamlūk period and were built upon the remains of the Hellenistic perimeter wall (A.11:49). A vaulted room, partially excavated in Square 9 in 1974, continued into Square 11. Although the vaulted roof was no longer intact (as partially in Square 9), evidence of the springer stones and collapsed arches (A.11:21) was found. The dirt fill in the room contained numerous Mamlūk sherds.

Another room in Square 11, located in the southeast part and formed by Walls A.11:7 (continuation of A.9:2), A.11:23, and A.11:3 (continuation of A.9:33), was the west portion of the room

⁴ *AUSS* 11 (1973): 19-20.

⁵ *AUSS* 14 (1976): 20-21.

identified in the southwest part of Square 9 in 1974. The latest sherds in the debris and dirt fill (A.11:2) in the room dated it to the Mamlūk period. Below this a plaster floor (A.11:8) was found also dating from the Mamlūk period. Later, with the removal of the north balk in Square 10, the doorway into this room was uncovered.

Extensive Mamlūk evidence was uncovered in Square 10. The ground surface contained scattered building stones from the superstructure, and the latest sherds dated from the Mamlūk period. In the southwest corner a 2.40 x 3.00 m. room was identified. This was not completely excavated but clearly was dated to the Mamlūk period on the basis of its association with other architectural features in the Square. East of this room a hallway containing a number of surfaces (A.10:11, 12, 13, 17) and a small room (Walls A.10:6, 7, 8, 9) were uncovered. These also dated in the Mamlūk period. The main feature uncovered in Square 10 was the intact pavement (A.10:20) in the northeast sector of the Square measuring 5.00 m. (east-west) by 5.30 m. (north-south). On its west side was a platform (A.10:22), .40 m. above the pavement on which some traces of plaster (A.10:18) were preserved. Another similar installation (A.10:24) on the east side of the pavement was found. This was built against the west wall (A.8:16) of the bath complex and stood about .60 m. above the pavement. The latest sherds in all the debris above the pavement and platforms dated from the Mamlūk period (see Pl. II:A).

The presence of the springer stones (A.10:27) of an arch in the walls on the north and south side of the west platform indicated that there was an arch or vaulted roof over the platform. The removal of the north balk of Square 10 (necessary to expose the entire Platform A.10:24) uncovered a hallway along the east side of the southeast room.

Squares 10 and 11 contributed significantly to the understanding of the Mamlūk occupation of the acropolis. The bath complex, although completely sealed off from the Mamlūk remains

in Squares 9 and 10, was an integral part of the total Mamlūk occupation of the site. On the north and south sides of the small paved courtyard in Square 10 were rooms, possibly domestic quarters, lying between the bath complex and the west perimeter wall. These rooms on the north side in Square 9 were connected by two hallways. A similar arrangement appeared on the south side, although that was not as extensively excavated. When these architectural features on the west end of the acropolis were related to Mamlūk remains on the south side of the acropolis identified in Area D, one half of the U-shaped Mamlūk building complex on the acropolis was recognized. The Mamlūk occupation of the acropolis was not only extensive but also impressive.

Stratum IV: Ayyūbid (ca. A.D. 1200-1260)

It was possible to identify distinct Ayyūbid occupation in certain layers excavated in 1976. In Square 8 it was possible to probe below the level of the Mamlūk bath complex between the south balk and the entrance hallway of the bath. It was in the upper part of a soil layer (A.8:14) that Ayyūbid sherds were the latest and predominant evidence. In the southeast room in Square 11 below the Mamlūk level, Surfaces A.11:9, 10, 22, 26, and 27 were all dated to the Ayyūbid period. In the vaulted room in the northeast part of Square 11 a *ṭabun* (A.11:31) and its use surface (A.11:32) were clearly dated to the Ayyūbid period.

These evidences of Ayyūbid occupation in Squares 8 and 11 were discovered because the Mamlūk occupation level could be removed since it did not involve significant architecture to be preserved. However, since Ayyūbid occupation has been detected in these two Squares at some distance apart, it may be concluded that the Ayyūbid occupation on the western part of the acropolis was relatively extensive.

Stratum V: 'Abbāsīd (ca. A.D. 750-969)

The 'Abbāsīd evidence was found in the same sectors as the

Ayyūbid evidence in Squares 8 and 11. In Square 8 this evidence was found successively in Soil Layer A.8:14, Surface A.8:30, Surface A.8:32, Surface A.8:33, Cobble Layer A.8:34, and Surface A.8:35. In Square 11 'Abbāsīd material was identified in Surface A.11:34 and Soil Layer A.11:41 in the southeast room. As with the Ayyūbid evidence, these were the only places where such penetration below the Mamlūk remains was possible. Similarly, the scattered evidence suggested extensive 'Abbāsīd occupation of the western part of the acropolis.

Stratum VI: Umayyad (ca. A.D. 661-750)

The major evidence for Umayyad occupation of the acropolis was the large *ṭabun* in Square 7 (A.7:73), uncovered in 1973 and fully excavated in 1974.⁶ The size of this installation certainly suggested a major occupation of the site at the time. In Square 8 along the south balk, Surface A.8:36 was dated in the Umayyad period. Between it and the *ṭabun* (A.7:73) lay the bath complex. Hence, again the extent of the Umayyad occupation can only be measured by these scattered evidences.

Strata VII-VIII: Late Byzantine (ca. A.D. 450-661)

The major Byzantine structure uncovered in Area A was the Christian basilica whose east, north, and south walls were identified. The major section of the east wall was semicircular and enclosed the apse of the church. Two courses of this wall were preserved above the foundation level. On both sides of the apse were small chambers whose precise features had been extensively disrupted by later building operations.

The eastern half of the north wall was the header-stretcher type and the western half was the reuse of an earlier Roman wall made of tightly-fitted and well dressed stones. The south wall was well constructed. An arch was constructed in its eastern part where it passed over a large cistern. By this means the strain on

⁶ AUSS 13 (1975): 123-124; 14 (1976): 22-23.

the cavity was reduced. The western half of this wall lay outside the excavated part of Area A.

The western wall of the basilica could not be positively identified. Above the western part of the church the Islamic building complex with the bath (described above) was constructed in Squares A.7, 8, 9, 10, and 11. Since the Jordanian Department of Antiquities desired to preserve this Islamic architecture, it was not possible to excavate extensively below it. A few small probes revealed some traces of the basilica, but these were inconclusive to locate the western exterior wall of the basilica.

Numerous sections of the basilica pillars were in evidence—some lying on the surface, others uncovered in the course of excavating, and others found reused in later buildings. Likewise, numerous pillar bases were found—some in situ and some dislocated or reused. Portions of four bases in the north row were visible on the surface and found to be in situ. Two bases in situ in the south row were uncovered in Squares 4 and 6. These bases were resting on stylobate walls.

Traces of the mosaic floor of the basilica were found in various places along with numerous loose tesserae—indicating that the entire floor area was a mosaic pavement. The presence of a mosaic floor superimposed on an earlier floor in Square 6 and in the south aisle in Squares 3 and 4, and of the mosaic and lower surface in the apse (Square 3) establishes two phases for the basilica. A sizable portion of the upper apse mosaic (A.3:3) was uncovered in 1968.⁷ Its similarity to other dated mosaics in the Madaba area suggests a mid-sixth-century date for this phase (Stratum VIII). Other traces of this upper mosaic in the basilica proper were found in the nave in Square 4;⁸ in the south aisle, in Squares 3 and 4;⁹ in Locus A.6:47;¹⁰ and in the north aisle

⁷ *AUSS* 7 (1969): 148-149.

⁸ *AUSS* 7 (1969): 152-153.

⁹ *AUSS* 13 (1975): 128-130.

¹⁰ *AUSS* 13 (1975): 124-126.

(south of Walls A.7:12 and A.9:33), in A.7:76 and 9:99. This consisted of white tesserae, perhaps indicating a utilitarian rather than decorative function in the western part of the church.

In 1973 evidence of an anteroom north of the basilica from this later phase was found in Squares 5 and 7.¹¹ The exact size of the room could not be ascertained because of reuse in Umayyad times when the central part of the mosaic was removed for the installation of the *ṭabun* (see above).

Extensive traces of the mosaic floor in the south sacristy were uncovered in 1968 and 1971. It appears that the doorway from the south aisle into the room was blocked during the latter part of the second phase of the church.¹² From these scattered traces of mosaic floors in all parts of the basilica it is evident that this sixth-century building was beautifully decorated.

The earlier phase of the church is evidenced by the extensive *huwwar* surface (A.3:7) in the apse¹³ and by the lower mosaic in Square 6 (A.6:48).¹⁴ Further work on this was done in 1976 with the removal of the badly eroded balk between Squares 6 and 8. This work substantiated the judgment in 1973 from the design of the mosaic with its border, that the west wall of the earlier basilica was located here. This indicates that the earlier basilica was shorter than the later one. Similarly, no trace of an earlier mosaic was found in the western end of the north aisle in Squares 7 and 9, nor under the mosaic of the anteroom in Squares 5 and 7.

The date of this earlier phase of the church, as suggested by the typology of the mosaic and the potsherds, is late fifth to early sixth century. This would correlate with the evidence of similarly dated churches in Madaba, Mt. Nebo, and environs.

Strata XV-XVI: Late Roman (ca. A.D. 135-324)

The occupation of the acropolis was extensive during the

¹¹ *AUSS* 13 (1975): 122-124; 14 (1976): 24.

¹² *AUSS* 13 (1975): 130.

¹³ *AUSS* 7 (1969): 149.

¹⁴ *AUSS* 13 (1975): 126.

Roman period, although the remains are not extensive since the large basilica covered the major part of the Area and also reused some of the earlier architecture. The latest Roman evidence was found in the cave complex in Square 1 (Loci A.1:44 and A.1:67).¹⁵ However, the major Roman occupation can be dated to the transition period from Early Roman to Late Roman on the basis of work in Square 11 in the 1976 season. This could be correlated with data in Square 9 and in Square 6 providing evidence of a major structure on the acropolis in that period.

Strata XVI-XVII: Early Roman IV to Late Roman I
(ca. A.D. 70-193)

Earlier seasons had indicated that the basilica reused a well-constructed Roman wall for its north wall. This east-west wall began in Square 7 (Locus A.7:47), continued in Square 9 (A.9:33), and ended in Square 11 (A.11:3) against the perimeter wall on the edge of the acropolis. Another wall parallel to and north of this wall was Wall A.7:57 = 9:88 = 11:48. These walls could be dated precisely on the basis of foundation Trenches A.9:89 and 108 for Wall A.9:88, and A.9:110 for Wall A.9:33.

The massive size and impressive masonry of these parallel walls suggest some major structure. This is further indicated by similarly constructed platforms running north-south in Square 6 (A.6:65) which may have been the foundations for pillar bases. A north-south wall (A.6:69) parallel to these platforms but located west of them may have been the east wall of the main structure. Unfortunately, this lies below the bath complex and could only be partially exposed.

The perimeter wall along the western edge of the acropolis was reinforced with a sloping stone layer (A.11:15). A drainage channel (A.11:16) was identified in this layer. In the rooms formed by the massive parallel walls a dirt fill (A.11:42) and a surface (A.11:44) were identified and dated to the Early Roman period by the sherds. The storage complex uncovered in 1974 in

¹⁵ AUSS 11 (1973): 29-30.

BASTIAAN VAN ELDEREN

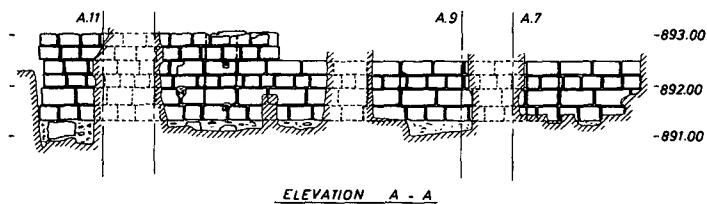
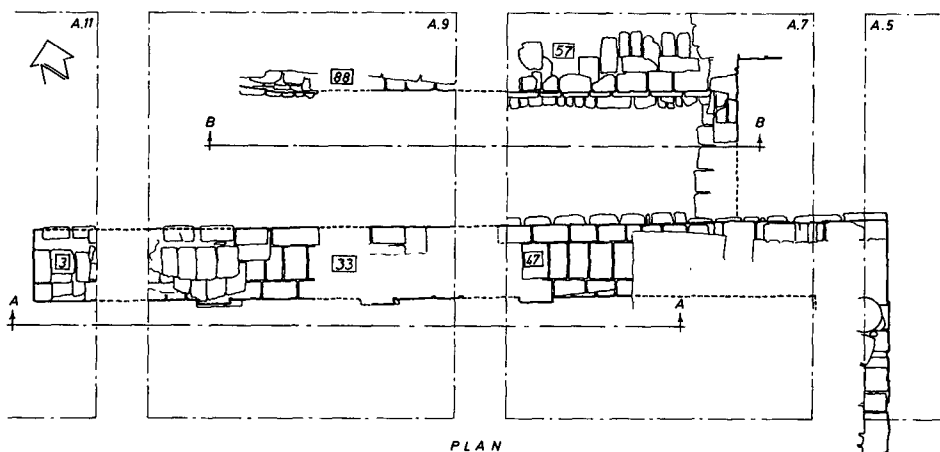
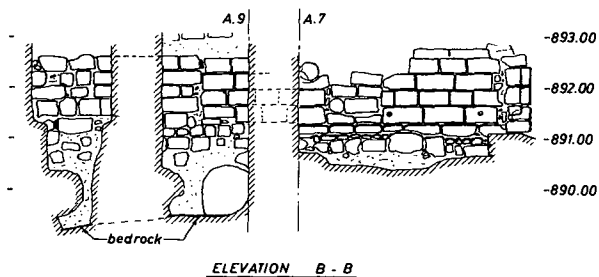

HESHBON 1976

AREA A SQUARES 5-9, 11

DRAWN AUGUST 1976 BY BERT DEVRIES, DANIEL SALZMANN & MERLING ALOMIA

ROMAN STRUCTURE

0 80 160 240 320 400M.

Fig. 3. The foundation of a major Roman Strata XVI-XVII building on the acropolis (cf. p. 27).

Square 5, lying north and east of these Roman walls, also dates in the same period.¹⁶

It is evident that much of the Roman occupation of the acropolis was cleared away for the Byzantine architecture. Nevertheless, those Roman features remaining certainly point to a major Roman building on the acropolis—perhaps a government building or temple.

Stratum XX: Late Hellenistic (ca. 198-63 B.C.)

The Hellenistic evidence on the acropolis was found in Square 11 in 1976. The lower part of the north-south perimeter Wall A.11:49 along the west side clearly dated to the Late Hellenistic period. Bonded to it was a Late Hellenistic wall running east-west. The Roman Wall A.11:3 was built on this Wall A.11:50. Associated with both of these Hellenistic walls were clearly identified Surfaces A.11:45, 47, and 54. Mixed in and between these surfaces were many large stones—suggesting intervening destructions. The last Hellenistic Surface (A.11:54) was on bed-rock (see Pl. II:B).

The Hellenistic evidence in conjunction with the western perimeter wall correlates very well with similar evidence regarding the southern perimeter wall uncovered in Area D. Whatever Hellenistic architecture there was on the acropolis was completely destroyed in the subsequent Roman and Byzantine constructions.

Summary

The acropolis in Area A was a natural location for major buildings. The five seasons of work here have confirmed their presence. In Mamlūk times a central court was surrounded on the north and south with buildings (the north side was not excavated but the accumulation of debris certainly suggests such a construction). On the west side was the bath complex and other rooms with a paved open courtyard. During the Byzantine period

¹⁶ *AUSS* 14 (1976): 27-28.

an impressive basilica graced the acropolis. In the Roman period there was a major building with imposing walls and possible pillars. The perimeter wall identified on the south and west sides pointed to a fortified acropolis in the Hellenistic period whose buildings have disappeared.

This is the extent of the history of the acropolis that can be recovered. Some Iron Age sherds suggest it may have been occupied in earlier periods, and, of course, Hellenistic and Iron Age occupations are known from elsewhere on the *tell*. However, the Roman architects apparently removed all of this earlier evidence as they built their structures on the bedrock.

AREA B AND SQUARE D.4

JAMES A. SAUER

American Center of Oriental Research
Amman, Jordan

Four Squares (B.2, B.4, B.7, D.4), all of which had been started in earlier seasons,¹ were worked in Area B in 1976.² Squares B.2 and B.4 were completed after only 2.5 weeks of work, while Squares B.7 and D.4 required 6 and 7 weeks respectively. Because a cave complex beneath bedrock was uncovered in the southwest corner of B.4, excavation in that Square extended somewhat beyond the 7.00 x 7.00 m. limits of the Square. The balk between Squares B.2 and B.7 was removed to expose the northeast corner of the Iron II/Persian Stratum XXII reservoir, but the other Area B balks were left intact. The main dump for Area B was again located to the south of Square D.4, but Squares B.1, B.2, and B.3 were also partially backfilled with dump materials.

Strata II-IV: Ayyūbid/Mamlūk (ca. A.D. 1200-1456)

*Description (Stratification):*³ Ayyūbid/Mamlūk remains of Strata II-IV (Area B strata 2-3) were attested in 1976 only in the southwest corner of Square B.4, beneath bedrock to the south of the Square proper.

¹ For the results of the 1968, 1971, 1973, and 1974 seasons in Area B, see D. M. Beegle, "Heshbon 1968: Area B," *AUSS* 7 (1969): 118-126; E. N. Lugenbeal and J. A. Sauer, "Seventh-Sixth Century B.C. Pottery from Area B at Heshbon," *AUSS* 10 (1972): 21-69; J. A. Sauer, "Heshbon 1971: Area B," *AUSS* 11 (1973): 35-71; J. A. Sauer, "Heshbon 1973: Area B and Square D.4," *AUSS* 13 (1975): 133-167; J. A. Sauer, "Heshbon 1974: Area B and Square D.4," *AUSS* 14 (1976): 29-62. The present report again assumes complete familiarity with the above reports.

² During the 1976 season, Larry G. Herr supervised the fieldwork in Area B.

³ Pre-excavation cleanup in Area B consisted of Loci B.2:127, B.4:276, B.7:18A, and D.4:84. These loci produced the following bones:

Sheep/Goat	61	Dog	6	U.D.	13
Cattle	1	Cat	3	Scrap	35
Large Mammal	7	Chicken	3		

One registered artifact, iron slag (Object 2227), came from cleanup Locus B.7:18A. Locus D.4:84 also produced two registered artifacts, a bronze half-ring (Object 2203) and an iron nail (Object 2210).

Opening up to the south beneath Bedrock Blocks B.4:192, 195 (the partially collapsed ceiling bedrock of Cave B.4:171, of Early Roman Stratum XVIII) was Cave B.4:283. Temporary Balk B.4:281, composed of Early Roman rubble along the south and west sides of Cave B.4:171, separated Cave B.4:171 from Cave B.4:283. Cave B.4:283 was medium-sized (ca. 2.00 m. wide east-west; ca. 2.50 m. north-south), with rubble to the east, the back side of intersected vertical Bedrock B.4:277 to the north, and Wall B.4:283B to the west. To the southwest, low Passageway B.4:285 led to numerous connected underground caves, cisterns, and arched rooms, ca. 50.00-100.00 m. in total area (explored but not excavated). Cave B.4:283 was ca. 2.00 m. high between its ceiling Bedrock B.4:284 (= B.4:192, 195 of Cave B.4:171) and its floor Bedrock B.4:283H, and it was only partially filled with debris. The uppermost soil layer in the cave was Ayyübid/Mamlük Layer B.4:283A(1), a thin layer which covered over thicker Layer B.4:283A(2) of Early Roman Stratum XVIII.

Description (Bones): The bones from Ayyübid/Mamlük Layer B.4:283A(1) and from Early Roman Layer B.4:283A(2), recorded together, were as follows:⁴

Sheep/Goat	163	Large Mammal	51	U.D.	94
Cattle	30	Pig	5	Scrap	151
Donkey	6	Chicken	22		

Description (Artifacts): The latest pottery which came from Locus B.4:283A(1) was Ayyübid/Mamlük, including two complete or near-complete glazed bowls which were resting on the layer. These bowls were among the registered artifacts from Locus B.4:283A(1):

B.4:283A(1)	2296	Glazed Bowl	B.4:283A(1)	2284	Glass Jar Frag.
B.4:283A(1)	2297	Glazed Bowl			

Interpretation: Cave B.4:283 would originally have been connected to the B.4:171, 247, 74 cave complex in B.4, which was constructed or at least in use during the Early Roman and Late Hellenistic periods (see below). During the Early Roman earthquake of 31 B.C. the B.4:195 bedrock ceiling of Cave B.4:171 collapsed, and Rubble B.4:281 probably blocked off the abandoned B.4:171 cave from the intact B.4:283 cave to the south.

During the Ayyübid/Mamlük period, Cave B.4:283 would again have been used, approached from the underground complex to the south through Passageway B.4:285. Cave B.4:283, Passageway B.4:285, and the underground complex to the south could then be compared to Vaulted Room D.4:24, Cave D.4:68, Tunnel D.4:70, and Cave D.4:80 to the south of D.4.⁵ The B.4

⁴ It is likely that most of these bones came from the thicker Early Roman B.4:283A(2) layer.

⁵ Sauer, "Heshbon 1974: Area B and Square D.4," pp. 31-37.

and D.4 underground complexes were both last used during the Ayyūbid/Mamlūk period, and they were both probably constructed or in use during the Early Roman and Late Hellenistic periods. It would seem likely that the two might even connect underground. If so, Cave B.4:283 would be part of a major underground complex, apparently domestic in function, and the latest use of the cave (Layer B.4:283A [1]) could tentatively be assigned (with Vaulted Room D.4:24) to Early Mamlūk Stratum III (ca. A.D. 1260-1400). See Pl. IV:B.

Strata IX-XIV: Early Byzantine (ca. A.D. 324-410ff.?)

Description (Stratification): Additional remains of Early Byzantine Strata X-XIV (Area B strata 5-9) were attested in Square B.7 in 1976.

In northern B.7, two Early Byzantine pits (B.7:12 = 21 and B.7:38) cut through Early Byzantine-Late Roman Strata XII-XV (Area B strata 7-10), robbing out two major portions of Late Roman Stairway B.7:20. In northeastern B.7, Pit B.7:12 = 21, beneath Ayyūbid/Mamlūk Pit B.7:4, and in northwestern B.7, Pit B.7:38, beneath Ayyūbid/Mamlūk Pit B.7:10, both apparently cut through soil Layer B.7:19B of Early Byzantine Stratum XII. The two pits definitely cut through Early Byzantine plaster and soil Layers B.7:22, 23 of Stratum XIII, and B.7:24, 25 of Stratum XIV. They also cut through Late Roman plaster and soil Layers B.7:26, 27 of Stratum XV, and robbed out large portions of Late Roman Stairway B.7:20 of Stratum XV down to foundation materials (B.7:35). Both pits contained large amounts of plaster rubble, and they were flat on top beneath Ayyūbid/Mamlūk Pits B.7:4, 10.

In southern B.7, the B.7:17 = 18B rock tumble layer of Early Byzantine Stratum XI lay beneath the B.7:5, 14 plaster and soil layers of Early Byzantine Stratum X. The layer contained numerous medium and large sized (ca. 0.25-0.75 m.) rocks, and it was cut off along the north by the B.7:4 and B.7:10 Ayyūbid/Mamlūk pits. The layer sloped down to the west and south, and it rested on top of plaster Layer B.7:19A of Early Byzantine Stratum XII.

Beneath the B.7:17 = 18B rock tumble layer of Early Byzantine Stratum XI was the B.7:19 thin plaster (B.7:19A) and thick soil (B.7:19B) layer of Early Byzantine Stratum XII. B.7:19A and upper B.7:19B were cut off to the north by the B.7:4 and B.7:10 Ayyūbid/Mamlūk pits. Lower B.7:19B sealed against the highest preserved step (Step 6) of Stairway B.7:20 in the middle of the Square, but in the northeast and northwest corners of the Square it was cut off by Early Byzantine Pits B.7:12 = 21 and B.7:38. B.7:19 sloped down to the west and south, and it rested on top of plaster Layer B.7:22 of Early Byzantine Stratum XIII.

Beneath the B.7:19 plaster and soil layer of Early Byzantine Stratum XII were the B.7:22 plaster layer and the B.7:23 soil layer of Early Byzantine Stratum XIII. Layers B.7:22, 23 sealed against Step 4 of Stairway B.7:20 in the middle of the Square, but they were cut off in the northeast and north-

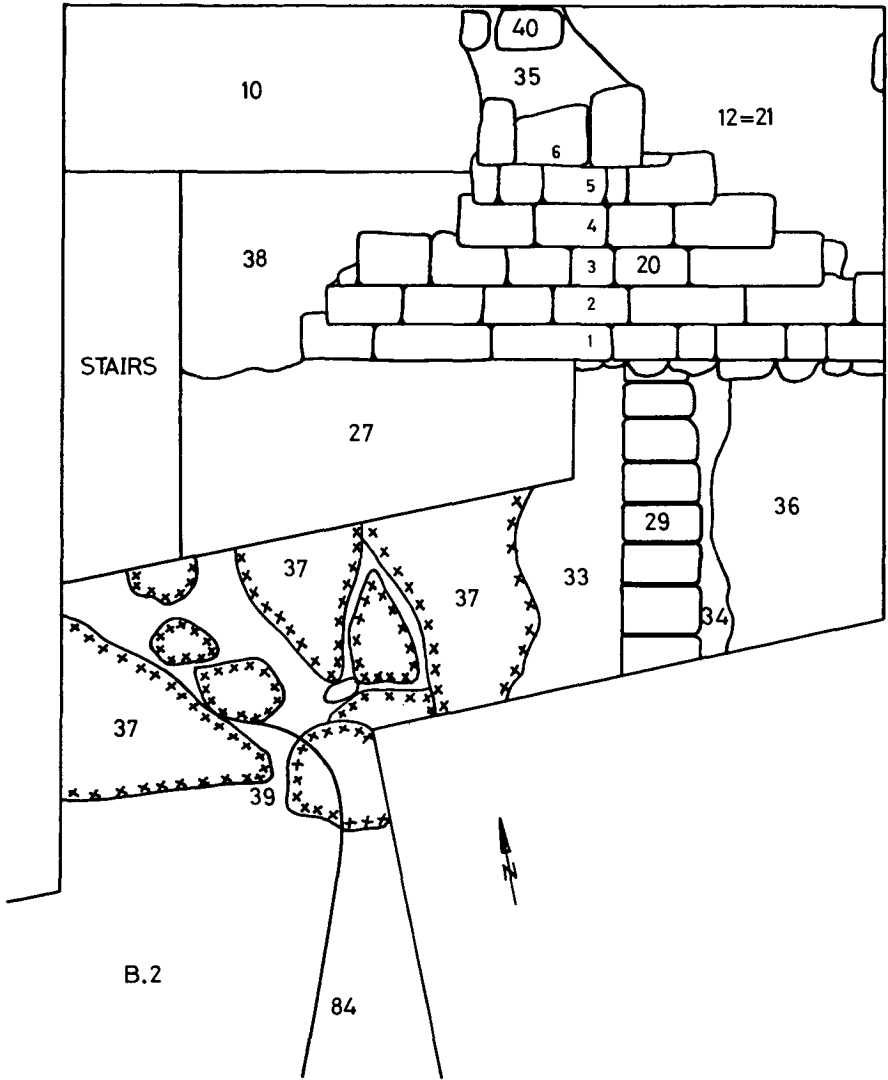

AREA SUPERVISORS

L. G. HERR, J. A. SAUER

SQUARE SUPERVISORS

R. GERATY, K. KNUTSEN

DRAFTSMAN

A. R. YOUSIF

Fig. 4. Composite plan of Square B.7, with balk removed between B.7 and B.2.

west corners of the Square by Early Byzantine Pits B.7:12 = 21 and B.7:38. Layers B.7:22, 23 sloped down gradually to the west and south, and they rested on top of plaster Layer B.7:24 of Early Byzantine Stratum XIV.

Beneath the B.7:23 soil layer of Early Byzantine Stratum XIII were the B.7:24 plaster layer and the B.7:25 soil layer of Early Byzantine Stratum XIV. Layers B.7:24, 25 sealed against Step 3 of Stairway B.7:20 in the middle of the Square, but they were cut off in the northeast and northwest corners of the Square by Early Byzantine Pits B.7:12 = 21 and B.7:38. Layers B.7:24, 25 sloped down very gradually to the west and south, and they rested on top of plaster Layer B.7:26 of Late Roman Stratum XV.

Description (Bones): Early Byzantine Pits B.7:12 = 21 and B.7:38 produced the following bones in 1976:

Sheep/Goat	16	Large Mammal	7	U.D.	20
Cattle	2	Chicken	2	Scrap	3
Donkey	2	Fish	1		

No bones came from the B.7:17 = 18B rock tumble layer of Early Byzantine Stratum XI, but the following bones came from the plaster and soil layers of Early Byzantine Strata XII-XIV:

Sheep/Goat	233	Camel	4	Chicken	7
Cattle	22	Large Mammal	108	Wild Bird	5
Horse	3	Pig	20	U.D.	43
Donkey	11	Cat	6	Scrap	577

Description (Artifacts): The latest pottery from the above loci was Early Byzantine. A 4th century A.D. coin (Object 2468) came from Locus B.7:19 of Early Byzantine Stratum XII. In addition, the following registered artifacts came from the Early Byzantine loci:

B.7:18B	2239	Iron Nail	B.7:19	2313	Sherd
B.7:19	2241	Bone Needle	B.7:19	2322	Millstone
B.7:19	2242	Bone Inlay	B.7:19	2392	Ivory Inlay
B.7:19	2244	Loomweight	B.7:19	2394	Knife, Rivets
B.7:19	2265	Iron Nail	B.7:21	2321	Iron Slag
B.7:19	2280	Pottery Disk	B.7:22	2634	Slingstone
B.7:19	2295	Ivory Sculpture	B.7:24	2410	Pestle Frag.

Interpretation: The Strata XII-XIV (Area B strata 7-9) plaster and soil layers could still be interpreted as roadway resurfacings, which now definitely ran up to the preserved portion of Late Roman Stairway B.7:20. The 4th c. A.D. coin from Stratum XII would agree with the ca. mid-4th-A.D. 365 date which was suggested in 1971 for that stratum.⁶

The Stratum XI rock tumble could also still be associated with the A.D. 365 earthquake.

Probably following the Stratum XI earthquake, in preparation

⁶ Sauer, "Heshbon 1971: Area B," pp. 59-60.

for Stratum X, Early Byzantine Pits B.7:12 = 21 and B.7:38 would have been dug to rob out many of the squared stones from Late Roman Stairway B.7:20. These stones would then probably have been used to build another stairway (cf. Early Byzantine Stairway D.2:34),⁷ at a higher level, perhaps on top of the flattened B.7:12 = 21 and B.7:38 pit fills themselves. Ayyūbid/Mamlūk Pits B.7:4, 10 cut down to these flattened fills, cutting at an angle through the B.7:5, 14 plaster and soil layers of Stratum X, the B.7:17 = 18B rock tumble layer of Stratum XI, and the B.7:19A plaster and upper B.7:19B soil layers of Stratum XII. The B.7:4, 10 Ayyūbid/Mamlūk pits could thus have robbed out the higher, Early Byzantine stairway, which could originally have rested on B.7:12 = 21 and B.7:38.

Strata XV-XVI: Late Roman (ca. A.D. 135-324)

Description (Stratification): Additional remains of Late Roman Strata XV-XVI (Area B strata 10-11) were attested in Area B (B.7, D.4) in 1976.

In central B.7, the wide B.7:20 stairway of Late Roman Stratum XV, built of finely squared rectangular stones, consisted of six preserved steps (each ca. 0.24 m. high and ca. 0.37 m. deep) which ran up from the middle of the Square towards the north balk. The stairway was a continuation in B.7 of Stairway D.3:39, and from the B.7 east balk the first two steps (Steps 1, 2) extended ca. 5.60 m. into the Square. In the northeast corner of B.7, the upper four preserved steps (Steps 3-6) of the stairway were robbed out by Early Byzantine Pit B.7:12 = 21; and in the northwest portion of B.7, all six steps were robbed out by Early Byzantine Pit B.7:38. In north-central B.7, however, beneath Ayyūbid/Mamlūk Pits B.7:4, 10, the possible foundation stones (B.7:40) for a seventh step were preserved above and to the north of Step 6. Step 6 itself was covered over by the B.7:17 = 18B rock tumble of Early Byzantine Stratum XI, and Steps 6-3 were sealed against by the plaster and soil layers of Early Byzantine Strata XII-XIV. The B.7:26, 27 plaster and soil layers of Late Roman Stratum XV sealed against Steps 2-1. Stairway B.7:20 was founded on Late Roman rock and rubble Layer B.7:35, above the B.7:28 thin plaster layers of Late Roman Stratum XVI.

Beneath the B.7:24, 25 plaster and soil layers of Early Byzantine Stratum XIV, the nearly level B.7:26, 27 plaster and soil layers of Late Roman Stratum XV sealed against Steps 2-1 of Stairway B.7:20, except in the northwest where Steps 2-1 had been robbed out by Early Byzantine Pit B.7:38.

Beneath the B.7:26, 27 plaster and soil layers of Late Roman Stratum XV, and also beneath the B.7:35 rock and rubble foundation for Stairway B.7:20 (unexcavated), was the fairly level B.7:28 Late Roman plaster layer of Stratum

⁷ Herr, "Heshbon 1976: Area D," p. 121.

XVI. Layer B.7:28 consisted of four thin plaster layers, which formed the uppermost portion of a ca. 0.50 m. thick composite plaster layer. Beneath the thin B.7:28 plaster layers of Late Roman Stratum XVI were the thin B.7:30 plaster layers of Early Roman Stratum XVII.

In southwestern D.4, beneath the D.4:38 = 69 soil layer of Late Roman Stratum XV, was heavy boulder Wall D.4:88, which ran east-west through the middle of the Square. Along its north face its D.4:90 foundation trench cut through the D.4:85, 92, 96 thin plaster layers of Late Roman Stratum XVI, as well as the D.4:98 plaster layer of Early Roman Stratum XVII. To the south, Wall D.4:88 was sealed against by Late Roman rock tumble Layer D.4:94,⁸ which covered over north-south Wall D.4:86 = 103, 100 of Early Roman Stratum XVII. Beneath rock tumble Layer D.4:94 was rubble Layer D.4:99 = 105 = 106, which also sealed against Wall D.4:88, as well as against Wall D.4:86 = 103, 100 of Early Roman Stratum XVII. To the west, Wall D.4:88 butted up against north-south Wall D.4:86 = 103, but to the east it was cut off by the D.4:17, 10 foundation trenches of the D.4:2, 13 Ayyūbid/Mamlūk structure. Wall D.4:88 was one course high, and it was founded on Cobble D.4:110, which rested on top of earlier bedrock-founded Wall D.4:112.

In northern D.4, beneath the D.4:38 = 69 soil layer of Late Roman Stratum XV, were the D.4:85, 92, 96 thin patchy plaster layers of Late Roman Stratum XVI. To the south, these Stratum XVI layers were cut off by the D.4:90 foundation trench of Wall D.4:88, and to the southeast they were again cut by the D.4:17, 10 foundation trenches of the D.4:2, 13 Ayyūbid/Mamlūk structure. To the east, Layers D.4:85, 92, 96 sealed against the D.4:45 = 109 stepped sill of Wall D.4:32B.⁹ To the north, they sealed against Bedrock D.4:93 and Wall D.4:97 = 114 = 127, a large boulder wall in the north balk which filled the space between Bedrock D.4:93 and Wall D.4:32B. In the northwest corner of the Square, the Stratum XVI layers sealed against the two squared stones of Wall D.4:83, which rested on top of Wall D.4:86 = 103 of Early Roman Stratum XVII. Along the west balk, the layers ran over north-south Wall D.4:86 = 103. Layers D.4:85, 92, 96 of Late Roman Stratum XVI were uneven but fairly level throughout northern D.4, and they covered over the D.4:98, 108, 101 plaster and soil layers of Early Roman Stratum XVII.

Description (Bones): The Late Roman loci of Stratum XV produced the following bones in 1976:

Sheep/Goat	359	Large Mammal	32	Fish	100+ ¹⁰
Cattle	23	Pig	24	U.D.	175
Horse	1	Dog	3	Scrap	547
Camel	1	Chicken	18		

⁸ Locus D.4:89 was access-stairway removal above Locus D.4:94 which produced Early Byzantine pottery, a button fragment (Object 2301), and the following bones: Sheep/Goat 4; Large Mammal 4; Dog 1; Chicken 2; Scrap 18. Locus D.4:102 was a temporary balk along the west balk, above Wall D.4:100, 86 = 103, which probably equaled Locus D.4:94. It produced Late Roman pottery as well as the following bones: Sheep/Goat 6; Large Mammal 3; Chicken 1; U.D. 4; Scrap 17.

⁹ Locus D.4:91 was a possible foundation trench for Wall D.4:32A, which cut into Layer D.4:85 but not into Layers D.4:92, 96.

¹⁰ The 100+ fish bones all came from Locus D.4:69.

From Loci D.4:88, 90, 94, 99 = 105 = 106, 110 came the following bones:

Sheep/Goat	118	Pig	4	Fish	1
Cattle	9	Dog	4	U.D.	47
Donkey	2	Small Mammal	1	Scrap	277
Large Mammal	12	Chicken	14		

The Late Roman loci of Stratum XVI produced the following bones:

Sheep/Goat	44	Large Mammal	3	Scrap	135
Cattle	2	Chicken	5		
Pig	2	U.D.	18		

Description (Artifacts): The latest pottery from the loci of Stratum XV was Late Roman III-IV, and from the loci of Stratum XVI, Late Roman I-II. Loci D.4:88, 90, 94, 99 = 105 = 106, 110 produced mixed Late Roman and Early Roman pottery.

Five coins came from the above loci, as follows:

B.7:35	2669	Nabataean	D.4:99	2470	3rd c. A.D.
D.4:69	2317	Nabataean	D.4:99	2479	A.D. 146-161
D.4:92	2480	103-76 B.C.			

In addition, the above loci produced the following registered artifacts:

B.7:27	2502	Frit Bead	D.4:99	2508	Loomweight
B.7:27	2548	Iron Pieces	D.4:99	2509	Loomweight
B.7:35	2649	Bone Frag.	D.4:99	2510	Loomweight
D.4:85	2370	Weight Frag.	D.4:99	2443	Mortar
D.4:85	2371	Iron Hook	D.4:99	2444	Grinder
D.4:94	2351	Glass Button	D.4:106	2503	Bead
D.4:99	2507	Loomweight			

Interpretation: Stairway B.7:20 of Late Roman Stratum XV was the westward extension of Stairway D.3:39, and together they had a preserved length of ca. 11.80 m. Because Stairway B.7:20 was robbed out to the west by Early Byzantine Pit B.7:38, it is not possible to determine the original length of the stairway. Six steps of the monumental stairway were preserved in B.7, but there was evidence in Area D that the stairway once ran up the slope much farther,¹¹ probably to service a Roman temple on the acropolis (see Pl. V:A).

The plaster and soil layers of Late Roman Stratum XV in B.7 and D.4 would have belonged to the first wide roadway that was in use with the B.7:20 stairway. That roadway would have run

¹¹ Geraty, "Heshbon 1973: Area D," pp. 196-199.

over to Wall D.4:32A on the east, and it would have covered over the earlier Stratum XVI remains, including associated Wall D.4:83.

Beneath Stratum 10 in D.4, Wall D.4:88 and associated Loci D.4:90, 94, 99 = 105 = 106, 110, which cut down into Late Roman Stratum XVI and Early Roman Stratum XVII, could perhaps represent the disturbed foundational remains of Stratum XVI or Stratum XVII architecture which would have been partially robbed out or leveled in preparation for the Stratum XV roadway.

The thin plaster layers of Late Roman Stratum XVI in B.7 and D.4 would represent portions of the wide Area B roadway which preceded the construction of Stairway B.7:20. It was not determined how far north of B.7 the layers ran. To the east of B.7, it would seem likely that the Stratum XVI layers ran over to north-south Wall D.3:47A,¹² which would seem to equal Wall D.4:83 in the northwest corner of D.4. In D.4, the Stratum XVI plaster layers sealed against Wall D.4:83, covered over the D.4:86 = 103 wall of Early Roman Stratum XVII, and sealed against the D.4:45 = 109 stepped sill of Wall D.4:32B. Since Wall D.4:83 would seem to have been, like Wall D.4:32B, the north side of a doorway or open entryway, it could have been to this entryway that the Stratum XVI plaster layers ran on the east.

With the possible exception of the two coins from Locus D.4:99, the five coins which came from the Late Roman loci did not contribute significant new evidence for dating Strata XV-XVI.

Strata XVII-XIX: Early Roman (ca. 63 B.C. - A.D. 135)

Description (Stratification): Additional remains of Early Roman Stratum XVII (Area B stratum 12) and Stratum XVIII/XIX (Area B stratum 13, post-earthquake, pre-earthquake) were attested in Area B (B.4, B.7, D.4) in 1976.

In southern B.7, south of unremoved Late Roman Stairway B.7:20, the Early Roman remains of Stratum XVII lay beneath the B.7:28 thin plaster layers of Late Roman Stratum XVI. Plaster Layer B.7:30 of Early Roman Stratum XVII consisted of two thin, level plaster layers which covered over Paving B.7:29 and associated plaster Layers B.7:31, 32, also of Early Roman

¹² *Ibid.*, p. 199.

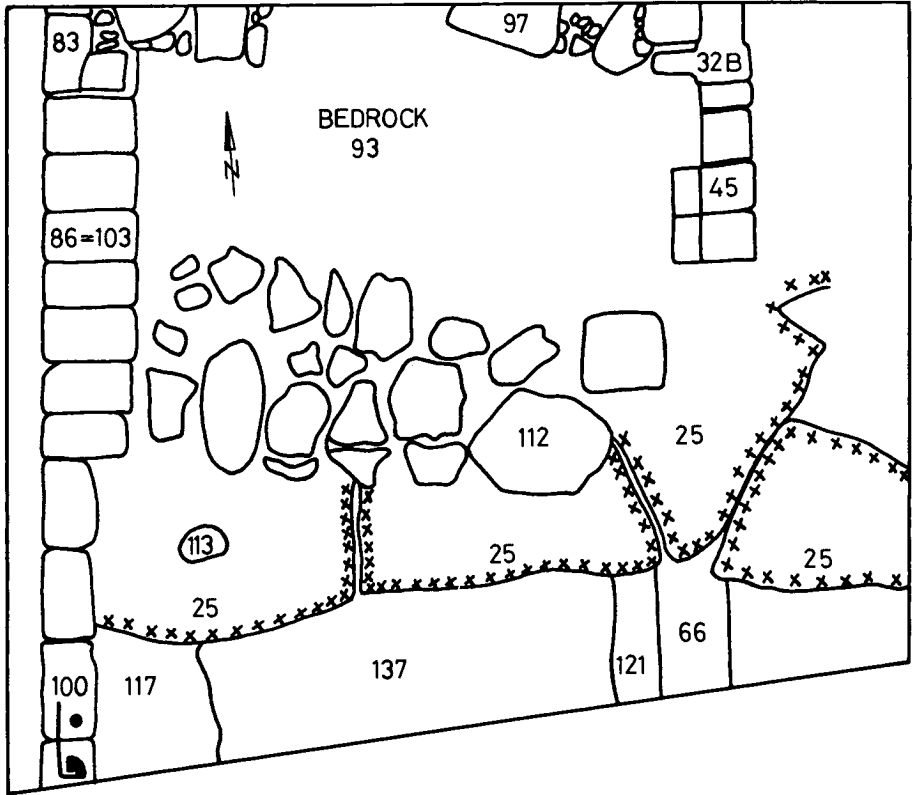

AREA SUPERVISORS

L. G. HERR, J. A. SAUER

SQUARE SUPERVISORS

D. CASEBOLT, L. MITCHEL

DRAFTSMAN

A.R. YOUSIF

Fig. 5. Composite plan of Square D.4.

Stratum XVII. Paving B.7:29, consisting of eight rectangular-cut (ca. 0.38 x 0.80 x 0.28 m.) level stones, ran north-south into the Square from the south balk, parallel to and ca. 1.75 m. from the east balk. Early Roman plaster Layer B.7:31 sealed against Paving B.7:29 on the east, and plaster Layer B.7:32 sealed against it on the west. Beneath plaster Layers B.7:31 and B.7:32 respectively were Early Roman soil Layers B.7:36 (unexcavated) and B.7:33, which were apparently cut in B.7 along Paving B.7:29 by Early Roman foundation Trench B.7:34. Beneath soil Layer B.7:33 of Early Roman Stratum XVII was Bedrock B.7:37, broken up into large blocks. In the excavated south balk (between B.7 and B.2), soil Layer B.7:33 covered over the B.7:39A soil layer of Hellenistic Stratum XXI, which filled the B.7:39 bedrock-cut corner of the Iron II/Persian Stratum XXII reservoir.

In northern D.4, beneath the D.4:85, 92, 96 thin patchy plaster layers of Late Roman Stratum XVI, lay the D.4:98 thin plaster layer and D.4:108, 101 soil layer of Early Roman Stratum XVII. To the south, the D.4:98 plaster layer was cut through by the D.4:90 foundation trench of Wall D.4:88, 110, but the D.4:108, 101 soil layer sealed against and partially covered over bedrock-founded, boulder Wall D.4:112. To the southeast, Stratum XVII Layers D.4:98, 108, 101 were cut off by the D.4:17, 10 foundation trenches of the D.4:2, 13 Ayyūbid/Mamlūk structure. To the east, Layers D.4:98, 108, 101 sealed against the lower portion of the D.4:45 = 109 stepped sill of Wall D.4:32B.¹³ To the north, they sealed against and covered over Bedrock D.4:93, including the entrance to Cave D.4:116 = 118 (which contained soil Layer D.4:118A). To the west, Layers D.4:98, 108, 101 sealed against north-south Wall D.4:86 = 103. Plaster Layer D.4:87, exposed at the west balk but not excavated, sealed against the other side of Wall D.4:86 = 103 from the west (B.3).

Wall D.4:86 = 103, 100 of Early Roman Stratum XVII ran north-south along the west balk of D.4, beneath Wall D.4:83 and the D.4:85, 92, 96 plaster layers of Late Roman Stratum XVI in the north, and beneath the D.4:94 Late Roman rock tumble layer in the south. The wall was constructed of ca. 0.45 x 0.75 m. rectangular stones, and it was two courses high. The upper course consisted of seven headers in the north and four stretchers in the south, and the two southernmost stretchers formed Sill D.4:100, which had a doorway socket with dragmarks from an eastward-opening door. The lower course was constructed entirely of stretchers, which rested on an unexcavated rubble foundation above bedrock. To its east, in central D.4, Wall D.4:86 = 103 was butted up against by bedrock-founded boulder Wall D.4:112, beneath Wall D.4:88, 110.

In southwestern D.4, to the south of Wall D.4:112, soil Layer D.4:107 of Early Roman Stratum XVII, beneath the D.4:99 = 105 = 106 Late Roman rubble foundation above bedrock. To its east, in central D.4, Wall D.4:86 = 103, 100, as well as against boulder Wall D.4:112. To the east, soil Layer D.4:107 was cut off by the D.4:17, 10 foundation trenches of the D.4:2, 13

¹³ Locus D.4:95 and Locus D.4:104 were makeup layers beneath step D.4:51, on the east side of Wall D.4:32B.

Ayyūbid/Mamlūk structure. Layer D.4:107 covered over Bedrock D.4:25,¹⁴ including bedrock-cut oval (ca. 0.40 x 0.45 m.) Installation D.4:113, which was ca. 0.40 m. deep. Layer D.4:107 also covered over and ran up against the ca. 2.25 m. deep D.4:117 rock-filled pit of Early Roman Stratum XVII, which lay beneath Wall D.4:100 and which cut down into the D.4:115 ff. Iron I soil layers of Stratum XXIV. Also beneath Layer D.4:107 of Stratum XVII were the D.4:120, 122, 123 remains of Early Roman Stratum XVIII/XIX, and the D.4:115 ff. soil layers of Iron I Stratum XXIV.

Beneath the substantial remains of Early Roman Stratum XVII in D.4, only tattered and sometimes unsure remains of Early Roman Stratum XVIII were preserved. In northern D.4, the entrance to Cave D.4:116 = 118 (ca. 1.75 m. wide and ca. 0.60 m. high beneath Bedrock D.4:93) lay beneath the D.4:98, 108, 101 plaster and soil layers of Early Roman Stratum XVII. In central D.4, boulder Wall D.4:112, unexcavated above Bedrock D.4:93, 25, was probably constructed during Stratum XVII, but it could possibly have existed already during Stratum XVIII. In southern D.4, beneath the D.4:107 soil layer of Early Roman Stratum XVII, the D.4:113 oval bedrock-cut installation could have belonged to Stratum XVIII. Also beneath Layer D.4:107 in southern D.4 were Loci D.4:120, 122, 123, which ran into the Square from the south balk to Bedrock D.4:25. Loci D.4:120, 122 constituted a possible rubble and boulder wall, two or three courses high, and beneath them was thin plaster Layer D.4:123, which sloped down to the north into an unexcavated cave beneath Bedrock D.4:25. Loci D.4:120, 122, 123 of Early Roman Stratum XVIII cut down into the D.4:115 ff. soil layers of Iron I Stratum XXIV, but to the east they were cut off by the D.4:17 foundation trench for Ayyūbid/Mamlūk Wall D.4:2.

In the southwestern corner of B.4, Early Roman Rubble B.4:281 of post-earthquake Stratum XVIII blocked off Cave B.4:171 from Cave B.4:283, located to the south outside the Square proper (see above, Ayyūbid/Mamlūk). Inside Cave B.4:283, beneath the thin B.4:283A(1) soil layer of Ayyūbid/Mamlūk Strata II-IV, were Early Roman soil Layers B.4:283A(2), 283C, 283F, 283G of post-earthquake Stratum XVIII, which rested on floor Bedrock B.4:283H. Beneath Layer B.4:283C in the center of the cave were partially excavated Layers B.4:283D, 283E, which could possibly belong to pre-earthquake Stratum XVIII. Unexcavated beneath Layers B.4:283D, 283E, 283F was the ca. 1.20 m. circular opening to Cistern B.4:283I, which was cut into floor Bedrock B.4:283H.

Also in southwestern B.4, but inside the Square, Early Roman Pit B.4:264 = 270 of pre-earthquake Stratum XVIII, partially excavated in 1974, cut down in front of Cave B.4:171 along vertical Plaster B.4:282 = 190 and vertical Bedrock B.4:277 = 191 = 195 = 192 of the Iron II/Persian Stratum XXII reservoir. Early Roman Pit B.4:264 = 270 cut down into the sloping soil layers of Hellenistic Stratum XXI, Layers B.4:272, 273, 274, 280 to the north, and Layers B.4:278, 279 to the south.

Description (Bones): The Early Roman loci of Stratum XVII produced the following bones in 1976:

¹⁴Locus D.4:111 was a thin soil layer on one part of Bedrock D.4:25, beneath D.4:107, which apparently produced a small quantity of Iron I sherds.

Sheep/Goat	274	Large Mammal	45	Fish	1
Cattle	34	Pig	5	U.D.	128
Donkey	2	Chicken	20	Scrap	428

From the Early Roman loci of Stratum XVIII came the following bones:¹⁵

Sheep/Goat	149	Large Mammal	22	Chicken	19
Cattle	12	Pig	4	U.D.	109
Donkey	1	Dog	3	Scrap	140
Camel	2	Rodent	1		

Description (Artifacts): The latest pottery from the loci of Stratum XVII was Early Roman III-IV. From the loci of post-earthquake Stratum XVIII came Early Roman II-III pottery, and from the loci of pre-earthquake Stratum XVIII, Early Roman I pottery. An undated Maccabean coin (Object 2662) and an undated Nabataean coin (Object 2663) came from Loci D.4:101 and D.4:107 respectively, of Early Roman Stratum XVII. In addition, the Early Roman loci produced the following registered artifacts in 1976:

B.4:283A(2)	2311	Bronze Pin	D.4:107	2569	Millstone
B.4:283C	2389	Iron Rivet	D.4:107	2570	Millstone
D.4:107	2541	Loomweight	D.4:108	2486	Bead
D.4:107	2542	Loomweight	D.4:118A	2583	Loomweight
D.4:107	2558	Loomweight	D.4:118A	2598	Hook
D.4:107	2559	Loomweight	D.4:120	2621	Loomweight
D.4:107	2564	Iron Hook			

Interpretation: The Early Roman remains of Stratum XVII in B.7 and D.4 would have belonged to the first major roadway complex in Area B. Paving B.7:29 was the northward extension of Paving B.4:72 = B.3:31, but it was not determined (beneath unremoved Late Roman Stairway B.7:20) how far north Paving B.7:29 continued. Paving B.4:72 = B.3:31 = B.7:29 would have run parallel to Wall D.4:86 = 103, 100 (= D.3:47B),¹⁶ which was two courses high. The plaster layers of Stratum XVII (including B.7:30, 31, 32; D.4:87) would probably have sealed against the west face of Wall D.4:86 = 103, 100 (= D.3:47B), and thus that long wall would probably have marked the eastern boundary of the Stratum XVII roadway. Sill D.4:100 would probably indicate that there was an entryway through Wall D.4:86 = 103. In north-eastern D.4, Sill D.4:45 = 109 would probably indicate that there

¹⁵ The bones from Locus B.4:283A(2) have been cited above with the bones from Ayyūbid/Mamlūk Locus B.4:283A(1). See n. 4.

¹⁶ Geraty, "Heshbon 1973: Area D," p. 201.

was another entryway to the east, and the D.4:98 thin plaster layer would probably have been the use surface between those two entryways. In southern D.4, however, the D.4:94 and D.4:99 = 105 = 106 Late Roman remains would have disturbed the use surface of Early Roman Stratum XVII associated with Sill D.4:100 (see Pl. V:A, B).

During the construction of the Stratum XVII roadway, Area B would have been leveled, and in the process, many of the preceding strata (Strata XVIII-XXIV) would have been damaged, including Early Roman Stratum XVIII/XIX. In B.7, no Stratum XVIII/XIX remains were preserved beneath the Stratum XVII roadway. In D.4, only minimal Stratum XVIII/XIX remains were attested, including the unexcavated cave beneath Bedrock D.4:25, which had a possible water channel running down to it (D.4:120, 122, 123). In B.4, where extensive Stratum XVIII/XIX remains were preserved, Cave B.4:283 would originally have been part of the B.4:74, 247, 171 cave complex, and this underground complex would also have extended a great distance to the south of Cave B.4:283 (see above, *Ayyūbid/Mamlūk*). The entire complex could originally have been cut in the Late Hellenistic period, and been cleaned out for reuse during the Early Roman period (pre-earthquake Stratum XVIII/XIX). Cave B.4:283 would have been in use during pre-earthquake Stratum XVIII/XIX, but unlike nearby Cave B.4:171, it would have been supported by Wall B.4:283B, and it would thus have survived the 31 B.C. earthquake to be partially filled up with post-earthquake Early Roman remains (like Cave B.4:74).

The two coins from D.4:101 and D.4:109 were not useful for refining further the dates of Early Roman Strata XVII-XVIII/XIX.

Strata XX, XXI: Late Hellenistic (ca. 198-63 B.C.)

Description (Stratification): Additional remains of Late Hellenistic Stratum XX (Area B stratum 14/15) were attested in D.4 in 1976. In B.2, B.4, and B.7, additional remains of Stratum XXI (Area B stratum 16) were also attested.

In southeastern D.4, beneath the D.4:17 foundation trench for Wall

D.4:2 and Arch D.4:57 of Ayyūbid/Mamlūk Strata II-IV, was the D.4:119, 121, 136 foundation trench for Wall D.4:66 (the west wall of vaulted Room D.4:24), of Late Hellenistic Stratum XX. Running from the south balk to Bedrock D.4:25, the D.4:119, 121, 136 foundation trench of Late Hellenistic Stratum XX cut down into the D.4:132, 134 ff. soil layers of Iron I Stratum XXIV.

The westward-sloping soil and rock tumble layers of Hellenistic Stratum XXI were attested in B.2 (B.2:128, 129, 130, 131, 132, 133, 134, 135, 136), in B.4 (B.4:278, 279, 280), and in the excavated balk between B.2 and B.7 (B.7:39A). In B.2, the Stratum XXI layers, beneath those excavated in 1974, rested on the B.2:137 clay layer of Iron II/Persian Stratum XXII (Area B stratum 17), and they sealed up against the B.2:113 plaster on vertical Bedrock B.2:114B (the eastern side of the Iron II/Persian reservoir of Stratum XXII [Area B stratum 18]). In B.4, Layers B.4:278, 279 to the south and Layer B.4:280 to the north (exposed but not excavated) were cut through by the B.4:264 = 270 pit of Early Roman Stratum XVIII/XIX, and they sealed against the B.4:282 = 190 plaster on vertical Bedrock B.4:277 = 191 = 195 = 192 (the eastern side of the Iron II/Persian reservoir of Stratum XXII [Area B stratum 18]). In the B.7 balk, beneath the B.7:33 soil layer of Early Roman Stratum XVII, the B.7:39A soil layer of Hellenistic Stratum XXI filled curving Bedrock B.7:39 (the northeast corner of the Iron II/Persian reservoir of Stratum XXII [Area B stratum 18]).

Description (Bones): Loci D.4:119, 136 of Late Hellenistic Stratum XX produced the following bones in 1976:

Sheep/Goat	19	Large Mammal	1	U.D.	13
Cattle	1	Chicken	2	Scrap	41

The bones from Stratum XXI have been cited as Iron II/Persian bone evidence (see below).

Description (Artifacts): The latest pottery from the loci of Stratum XX was Late Hellenistic. The Stratum XXI layers produced essentially pure Iron II/Persian pottery, with a few Iron I sherds, but several additional Hellenistic sherds came from the layers in 1976. The following registered artifacts came from the Late Hellenistic loci of Stratum XX:

D.4:119 2606	Loomweight	D.4:119 2611	Slingstone
D.4:119 2610	Slingstone	D.4:121 2625	Slingstone

The artifacts from Stratum XXI have been cited as Iron II/Persian evidence (see below).

Interpretation: The D.4:119, 121, 136 foundation trench for Wall D.4:66 would probably indicate that vaulted Room D.4:24 (without Arch D.4:57?) was constructed originally during Late Hellenistic Stratum XX. To the south, Cave D.4:68, Tunnel D.4:70, and Cave D.4:80 could also perhaps be attributed to Late Hellenistic Stratum XX, and they probably connected underground with Cave B.4:283 and the associated B.4:74, 247, 171

cave complex in B.4. Pool B.4:265 inside Cave B.4:247 was definitely in use during Late Hellenistic Stratum XX, and the other caves could have been cleaned out for reuse during the Early Roman occupation of pre-earthquake Stratum XVII/XIX. The unexcavated cave beneath Bedrock D.4:25 could also belong to Late Hellenistic Stratum XX, like the cave in B.3 which contained the circular B.3:47, 59, 64 Late Hellenistic "cisterns." Unexcavated circular "Cistern" B.4:283I inside Cave B.4:283 could either be compared to Late Hellenistic "Cisterns" B.3:47, 59, 64, or to "Cistern" B.4:188 in Cave B.4:74, which produced only Early Roman pottery. It should finally be noted that unexcavated Wall D.4:112 could conceivably belong to Late Hellenistic Stratum XX, like similar Wall B.1:17 = B.2:62, which ran up to and stopped at Bedrock B.2:114.

The few Hellenistic sherds in the Stratum XXI soil and rock tumble layers would indicate that the layers should still be interpreted as a massive fill, produced during the Hellenistic period when the Iron II/Persian remains on the acropolis were scraped off and dumped into the abandoned reservoir of Iron II/Persian Stratum XXII (Area B strata 17, 18). The fact that few Iron I sherds were attested in the Stratum XXI layers would suggest that the Iron I remains had been similarly scraped off at some earlier time, at least prior to the Iron II/Persian occupation at the site.

Stratum XXII: Iron II/Persian (ca. 800?-500 B.C.)

Description (Stratification): Additional remains of Iron II/Persian Stratum XXII (Area B strata 17, 18) were attested in Area B (B.2, B.4, B.7) in 1976.

In B.2, beneath the B.2:136 rock tumble layer of Hellenistic Stratum XXI was the ca. 0.20-0.40 m. thick, moist, gray clay Layer B.2:137 of Iron II/Persian Stratum XXII (Area B stratum 17). Clay Layer B.2:137 sealed against vertical Plaster B.2:113 and covered over horizontal "cement" Layer B.2:138 (the eastern side and floor of the Iron II/Persian reservoir of Stratum XXII [Area B stratum 18]).

In B.2, vertical Plaster B.2:113 on Bedrock B.2:114B of Iron II/Persian Stratum XXII (Area B stratum 18) was sealed against by the soil and rock tumble layers of Hellenistic Stratum XXI, and by the B.2:137 clay layer of Iron II/Persian Stratum XXII (Area B stratum 17). The "vertical" plaster sloped down gradually and evenly to the west, ca. 1.25 m. horizontally in ca.

5.75 m. of vertical drop. Beneath clay Layer B.2:137, Plaster B.2:113 met horizontal "cement" Layer B.2:138 of Iron II/Persian Stratum XXII (Area B stratum 18), which sloped down ca. 0.25 m. from the joint with Plaster B.2:113 to the west balk (at ca. 879.25 m.).

In the excavated balk between B.2 and B.7, beneath the B.7:33 soil layer of Early Roman Stratum XVII, and filled with the partially excavated B.7:39A soil layer of Hellenistic Stratum XXI, was westward-curving, vertical Bedrock B.7:39. Bedrock B.7:39, partially exposed, was the continuation of header-stretcher Wall B.2:84 and vertical Bedrock B.2:114B of Iron II/Persian Stratum XXII (Area B stratum 18). The excavated portion of Bedrock B.7:39 was not plastered, but some plaster seemed to be present just below the point where excavation ceased.

In southwestern B.4, cut down along by Pit B.4:264 = 270 of Early Roman Stratum XVIII/XIX, cut into from behind by Cave B.4:283 of Early Roman Stratum XVIII/XIX, and sealed against by the B.4:278, 279, 280 soil layers of Hellenistic Stratum XXI, was Plaster B.4:282 on vertical Bedrock B.4:277. Plaster B.4:282 and Bedrock B.4:277 were continuations of Plaster B.4:190 and vertical Bedrock B.4:191, 195, 192 of Iron II/Persian Stratum XXII (Area B stratum 18), and at the south balk they cornered fairly sharply to run west (beyond the Square).

Description (Bones): The Iron II/Persian clay Layer B.2:137 of Stratum XXII (Area B stratum 17) produced the following bones in 1976:

Sheep/Goat	21	Large Mammal	7	Scrap	12
Cattle	1	U.D.	4		

No bones came from the Iron II/Persian loci of Stratum XXII (Area B stratum 18), but the following bones came from the soil and rock tumble layers of Stratum XXI (see above, *Late Hellenistic*):

Sheep/Goat	578	Pig	1	Chicken	7
Cattle	80	Dog	7	U.D.	95
Donkey	12	Rodent	1	Scrap	169
Large Mammal	54	Turtle	6		

Description (Artifacts): The latest pottery from the B.2:137 clay layer of Stratum XXII (Area B stratum 17) was Iron II/Persian. No new pottery came from the loci of Stratum XXII (Area B stratum 18). The Stratum XXII (Area B stratum 17) clay layer produced the following registered artifact:

B.2:137 2581 Figurine Head

From the soil and rock tumble layers of Stratum XXI came the following registered artifacts (see above, *Late Hellenistic*):

B.2:133 2275 Ivory
 B.2:135 2531 Globular Frag.
 B.2:135 2309 Mortar Frag.

Interpretation: Clay Layer B.2:137, equaling clay Layer B.1:119 = 143, could still be interpreted as the final use during Stratum XXII (Area B stratum 17) of the Iron II/Persian reservoir of Stratum XXII (Area B stratum 18).

Several dimensions of the Stratum 18 reservoir could be considered confirmed as a result of the 1976 evidence. That "cement" Layer B.1:121 = 144 was the floor of the ca. 7.00 m. deep reservoir was confirmed by the joint between vertical Plaster B.2:113 (on Wall B.2:84 and vertical Bedrock B.2:114B) and horizontal "cement" Layer B.2:138 (= B.1:121 = 144). The westward-curving, bedrock-cut B.7:39 and B.4:277 = 192 corners confirmed the (slightly longer) ca. 17.50 m. length of the east side of the reservoir, and they would support the suggestion that the reservoir was approximately square (see Pl. III:A, B; IV:A).

Stratum XXIV: Iron I (ca. 1200-1100 B.C.)

Description (Stratification): Additional remains of Iron I Stratum XXIV (Area B stratum 19) were attested in Square D.4 in 1976.

Along the south balk in D.4, in the ca. 1.00 m. wide space between the south balk and vertical Bedrock D.4:25 to the north, Iron I remains of Stratum XXIV were attested beneath the D.4:107 soil layer of Early Roman Stratum XVII. The Iron I remains consisted of numerous superimposed soil, ash, and rock tumble layers (D.4:115, 124, 125, 126, 128, 129, 130, 131, 132, 133, 134, 135, 137, 138, 139, 140, 141, 142, 143, 144, 145, 146, 147, 148, 149, 150, 151, 152), ca. 4.00 m. in total depth, which sealed on the north against the ca. 5.50 m. long face of vertical Bedrock D.4:25.¹⁷ Vertical Bedrock D.4:25 sloped down gradually to the south and leveled out into the south balk beneath the 4.00 m. deep Iron I remains of Stratum XXIV. To the west, the Stratum XXIV remains were cut into deeply (ca. 2.25 m.) by the D.4:117 rock-filled pit of Early Roman Stratum XVII. In the center, they were cut into slightly (ca. 1.00 m.) by the D.4:120, 122, 123 remains of Early Roman Stratum XVIII/XIX. And to the east, they were cut into by the D.4:119, 121, 136 foundation trench for Wall D.4:66, of Late Hellenistic Stratum XX (Area B stratum 14/15).

Description (Bones): The Iron I loci of Stratum XXIV produced the following bones in 1976:

Sheep/Goat	179	Camel	1	Human ¹⁸	1
Cattle	77	Large Mammal	59	U.D.	118
Horse	1	Pig	10	Scrap	713
Donkey	15	Dog	1		
Equid	1	Chicken	3		

¹⁷ Another possible Iron I locus, thin Layer D.4:111, was located on top of Bedrock D.4:25, beneath Layer D.4:107 of Early Roman Stratum XVIII (see above, n. 14).

¹⁸ Robert M. Little, one of the anthropologists on the staff, prepared the following notes about the single human bone: "One right femur fragment. Both distal and proximal ends are missing. The bone is exceptionally dense

Description (Artifacts): The pottery from the above Stratum XXIV loci was Iron I, with nothing earlier. In addition, the following registered artifacts came from the Stratum XXIV loci in 1976:

D.4:138 2796 Loomweight

D.4:138 2797 Loomweight

Interpretation: The ca. 1.00 m. wide space between the south balk and vertical Bedrock D.4:25 would confirm the 1974 suggestion that a ca. 1.50-2.50 m. wide, ca. 4.00 m. deep, and ca. 13.00 m. long "channel" existed in Area B (B.2, B.3, D.4) during Iron I Stratum XXIV. That vertical Bedrock D.4:25 was probably the north side of a fairly narrow "channel" rather than the north side of a much larger "reservoir"¹⁹ is clear, at least in the southeast corner of D.4, where Bedrock D.4:67 formed the roof and sides of Cave D.4:68, ca. 2.00 m. to the south of vertical Bedrock D.4:25.²⁰ Although some traces of plaster were attested on vertical Bedrock B.3:84 = 90 in 1974, no plaster was found on vertical Bedrock D.4:25 in 1976, and the function of the "channel" must remain uncertain (water channel? defensive cut? occupational area?). Likewise, it has not yet been possible to determine whether the superimposed Iron I soil layers in the "channel" were deposited as gradual occupational debris or as rapid fill. The latter would seem to be more likely, and the Stratum XXIV layers could possibly represent Iron I materials which were scraped off or dumped from other parts of the site during or just after Iron IA (see Pl. V:B).

and heavy. The fragment is actually 0.34 m. long, but originally it was probably 0.43.8 m. long. Taking this as the femur length, the stature of the individual would have been 1.65.4 m. if male, and 1.59.5 m. if female. From the general circumference of the fragment and observing the overall piece, it would be judged to be male."

¹⁹ See L. T. Geraty, "Excavations at Tell Heshbân, 1976," *ASOR Newsletter* (January, 1977), p. 2.

²⁰ Sauer, "Heshbon 1974: Area B and Square D.4," pp. 35-36, 61-62; Figs. 4, 6.

AREA C.1, 2, 3, 5, 7

W. HAROLD MARE
Covenant Theological Seminary
St. Louis, Missouri

Area C was set along the main east-west axis of the site map down the west slope from the acropolis to the edge of the *tell*. In 1976, work was continued in Area C in Squares C.1, C.5, and C.7, and in each Square bedrock was reached. In the northwest sector of Square C.1, it was found that the Iron Age material had been cut through to set the bottom of the northeast corner of the Early Roman tower on bedrock. Work was continued in the north sector of Square C.5 in and around part of the tower complex, while in the south sector, that dump material which had been left unexcavated in previous seasons was now excavated from the ground surface down, along the south balk to bedrock. In the process, additional aspects of the tower were uncovered. In the north sector of C.7 further clearing was done in and around the Iron II/Persian wall down to bedrock. In the south sector, excavation showed that the Iron II/Persian wall ended or was interrupted by a doorway (with lintel) which led east and down to the entrance of a three-room cave cut in bedrock.

This report includes a description, analysis, and interpretation of (1) the work done in the 1976 season, and (2) the integration of this into an analysis and interpretation of all the work done in the various seasons, in C.1, 2, 3, 5, 7 (and also in G.6, 7 and 9—soundings excavated in 1974 in the *wadi* west of the *tell*, in which no further work was done in 1976).

Strata II-IV: Ayyūbid/Mamlūk (ca. A.D. 1200-1456)

Description: Additional evidence of Ayyūbid/Mamlūk Strata II-IV was found in Area C.1, 5, and 7 in 1976. Only loci with pottery fragments from

this period were attested, however, and no additional structural remains were found. Included were the between-season debris Loci C.7:45 (over the entire Square), C.1:119-122 (in the northwest corner of the Square), C.5:75 and 85 (north of the subsidiary south balk), and C.5:84 (south of the subsidiary balk to the true south balk). These loci evidenced contamination from the eroded balks and from the between-seasons erosion deposit which came down the west slope of the *tell*. In addition, in the southwest quadrant of C.7, there appeared one Ayyübid/Mamlük soil layer (C.7:46), and at the north balk of C.5 another (C.5:88) which was due to balk trimming there. Extensive excavation in C.5 in the sector south of the subsidiary balk produced a number of Ayyübid/Mamlük soil loci (C.5:87, 89, 91, 93, 94, 98, 99, 101, 103, 104, 111, 113, 134, 138, 142, 145, 148, 149, 151, 153, 156, 158, 160, 161, and 162) that filled the sector on ca. a 15-to-20-degree slope down east to west. They had accumulated to a depth of ca. 2.75 m. at the east balk and 1.75 m. at the west balk. The sector measured east-west 5.81 m. on the north and 5.99 m. on the south, and north-south 2.77 m. on the east and 3.54 m. on the west.

The four previous seasons of work in Area C.1, 2, 3, 5, and 7; and Area G.6, 7, 9 had produced a large quantity of evidence of Ayyübid/Mamlük occupation on this western slope of the *tell*. The structural remains showed themselves more prominently in the Squares farther east up the slope. C.7, 3, 2, and 1 showed such structures, but C.5, at the bottom of the slope, showed none.

Area G.6 and 7, down in the *wadi* west of the *tell*, also produced Ayyübid/Mamlük structures, while Area G.9, also in the *wadi*, yielded only Ayyübid/Mamlük sherds.

In C.7, at midpoint down the west slope of the *tell*, Loci C.7:2-12 included several wall fragments, all of Ayyübid/Mamlük construction; Loci C.7:13-37 and 39, primarily Ayyübid/Mamlük also, were soil layers found within, around, and under these wall fragments. Wall C.7:2 ran south from the north balk 2.40 m. to near, but not joined to, Wall C.7:3, which extended east 1.40 m. from the west balk. It was possible that Walls C.7:2 and 3, together with Installation C.7:12 (a semicircular row of stones abutting Wall C.7:2 on its west face and which could have been a manger) formed a part of an Ayyübid/Mamlük courtyard. Walls C.7:4, 5, and 6 were located in the southeast sector. Wall C.7:4 ran west from the east balk 1.45 m. Walls C.7:4 (east-west) and 2 (north-south) may have formed part of a room, possibly a domicile (cf. the bone needle found there in the hard-packed, pebbly brown soil) a part of which was preserved in the northeast corner of the Square. Wall C.7:5 extended north from the south balk for 2.50 m. and lay at a right angle to Wall C.7:4, while Wall C.7:6 lay southeast of Walls C.7:4 and 5.

Square C.3, just to the north of C.7, and lying north of the main east-west axis in line with C.2, 1 and 5, had several Ayyübid/Mamlük structures. Wall C.3:2 near the ground surface extended east from the west balk across the Square and then began to turn south as it neared the east balk. Wall C.3:3 at a level near the bottom of the ground-surface soil extended north from the south balk. Also in C.3 was Wall C.3:9 which extended 1.50 m. south from the north balk about 1.75 m. west of the east balk. Wall C.3:10, also in the northeast sector, was a rough line of stones tilted as if it were a course of stones fallen off a wall farther to the west, possibly Wall C.3:9. At the

subsidiary south balk toward the west balk, Loci C.3:45-47 consisted of layers of stone material, possibly part of a wall. These loci, together with soil Layers C.3:4, 5, 12, 13-15, 17, 22-23, 44, 49, 53, 61, 62; Surfaces C.3:7 for 2.50 m. (from the west balk east); and Surface C.3:11 (possibly a surface in the northeast sector of the Square) constituted the Ayyūbid/Mamlūk material in C.3.

Area C.2 produced two walls of the Ayyūbid/Mamlūk period. Wall C.2:5 extended from the west to the east balk at a point 3.00 m. south of the north-west corner of the Square. Wall C.2:11 entered into the west balk at the northwest stair. These walls together with Loci C.2:2, 3, 4, 6, 8 (a rock fall from the building at the north end of the Square); C.2:3 and 7 (a rock fall along the east and south balks); and the erosion material C.2:8, 9, and 16 (the latter covering the entire Square) constituted the evidence of the Ayyūbid/Mamlūk habitation in C.2.

Square C.1 produced in the ground surface soil an L-shaped wall (Loci 2-3) which extended north out of the south balk for 4.17 m. and then made a right turn into the east balk. Wall C.1:7 ran from the east balk at a point 2.50 m. south of the north balk and extended 8.00 m southwest. These walls together with soil Layers C.1:4, 5, 6, 10, 21, 74 and 102; and Surfaces C.1:9 and 11 (located in the north sector of the Square) constituted the evidence for the Ayyūbid/Mamlūk periods excavated in the 1968 to the 1974 season.

In Area C.5 Ayyūbid/Mamlūk dump or erosion deposit was encountered in the northern sector of the Square in 1971 and 1974 seasons in Loci C.5:1-5, 50-52, 54 to a depth of about 3.00 m. In the south sector in 1976 the same layering was encountered, as was indicated above, to a depth of about 1.75 m. to 2.75 m. But in this dump or erosion deposit there were no building remains found.

In Sounding G.6 all loci except one or two were dated Ayyūbid/Mamlūk (see the 1974 report) and this included north-south Wall G.6:8 and Vault G.6:9, which was west of Wall G.6:8 and faced west.

Sounding G.7 with its Walls 4, 6, and 7, together with accompanying soil Loci G.7:1-3, found north of Wall G.7:6, showed Ayyūbid/Mamlūk occupation, with only G.7:5, a soil and rock tumble indicating a possible earlier Byzantine occupation.

In Area G.9:1-4, the only loci excavated, only Ayyūbid/Mamlūk evidence appeared and no structures were attested.

Interpretation: In conjunction with the cumulative numismatic evidence from Area C.1, 2, 3, 5, 7, the Ayyūbid/Mamlūk loci may now be divided into two periods, that of Early Mamlūk Stratum III (A.D. 1260-1400) and that of Ayyūbid Stratum IV (A.D. 1200-1260).

The evidence from ground surface soil Locus C.2:1 with its Mamlūk coin (published coin 39 [registered object 131], A.D. 1293-1341) certainly dated it as no earlier than Stratum III, and the soil layers Loci C.1:4 and 6 with the later Mamlūk coin (published coin 44 [registered object 120], A.D. 1382-99) were

dated no earlier than late Stratum III. The L-shaped wall structure of C.1:2-3, C.2:5, and C.3:2, which extended east from C.1 through C.2 and C.3 for 15.00 m. and began to turn south in a broad curve as it entered the east balk of C.3 with its east face appearing in the west balk of C.4, belonged no earlier than Ayyūbid Stratum IV, based on the evidence of the coin (published coin 34 [registered object 197]) found in C.1:2. Though this coin was uncertain in date, it was thought to be of the Ayyūbid period. This L-shaped wall structure has been thought to be a courtyard wall.¹

Another structure within, to the south of, and more deeply founded than the courtyard just described, was that of Walls C.2:10 and C.3:3, which as it turned south into the south balk of C.3 may have included Wall C.7:2 (which was about at the same level and lineup as its counterpart, Wall C.3:3). All of this may have belonged to the house, part of which was in C.7 described above. Though there was no numismatic evidence here, it was concluded that this wall complex was properly Stratum IV (Ayyūbid). The structure of C.6 may also have been part of this house,² and was not earlier than Ayyūbid date (cf. published coin 293 [registered object 1769], A.D. 1193-98, from C.6:11).

This occupation may have corresponded to that of the Ayyūbid Pit B.7:4 with its D.2:16 = D.3:9 extension and possibly also to Pit D.4:7, 8,³ as well as to Cistern D.6:33.⁴

The C.5:1-5 loci seemed to represent a mixture of both Mamlūk and Ayyūbid materials with their Islamic coins of A.D. 1382-99 (published coin 94 [registered object 581]) in C.5:1, and of A.D. 1216-36 (published coin 74 [registered object 1020]) in C.5:2. The layers in the south sector of C.5 were taken to represent the same mixed Ayyūbid/Mamlūk dump or erosion deposit

¹ H. O. Thompson, "Heshbon 1968: Area C," *AUSS* 7 (1969): 130.

² W. H. Mare, "Heshbon 1974: Area C," *AUSS* 14 (1976): 74-75.

³ J. A. Sauer, "Heshbon 1974: Area B and Square D4," *AUSS* 14 (1976): 38.

⁴ L. T. Geraty, "Heshbon 1973: Area D," *AUSS* 13 (1975): 187; for coin evidence for D.6:33 see Sauer, *Heshbon Pottery 1971* (Berrien Springs, Michigan: Andrews University Press, 1973), pp. 57, 58.

coming down from the upper slopes.

Squares C.1, 2, 3, 5, and 7 also attested the Post-Stratum V Gap (A.D. 969-1200).

The Area G.6, 7, and 9 soundings represented the Ayyūbid/Mamlūk periods, there being no definitive evidence for a clearer demarcation of strata. The only coin here, that of G.9:2 (published coin 283 [registered object 1731]) was dated A.D. 306-37 and did not help in further differentiating the Strata.

Stratum V: 'Abbāsīd (ca. A.D. 750-969)

Description: No new 'Abbāsīd remains were dug in Area C.1, 5, 7 in 1976.

In previous seasons 'Abbāsīd loci were attested in Squares C.2, 3, 5, and 7, but no structural remains were encountered. There was an 'Abbāsīd Locus (C.7:21) and a possible one (C.7:35) in the northeast corner of C.7. Loci C.3:51 and 52 at the south balk of C.3, and also possibly the shallow fire Pit C.3:16 in the middle of the Square were dated to the period. In C.2 there was an 'Abbāsīd soil layer (C.2:18), extending over most of the Square, and continued by Loci C.2:20, 21, and 22, together with C.2:19 (a localized gray fire-ash layer extending west from the east balk). The only 'Abbāsīd material in C.5 was Locus C.5:53, a hard, red-brown soil layer with small *huwwar* stones, located in the southeast sector of the Square.

Interpretation: Based only on ceramic evidence, it was concluded that 'Abbāsīd habitation here and possibly elsewhere on the *tell* was extremely sparse. However, there seemed to be a small concentration of the evidence accumulated at the northeast corner of C.7 (C.7:35), the southwest corner of C.3 (C.3:51 and 52) and the south sector, particularly, of C.2 (C.2:18 and 22), that of C.2 being part of an accumulation dumped in from the slope above.

Stratum VI: Umayyad (ca. A.D. 661-750)

Description: There were no structures of the Umayyad Stratum uncovered in 1976, and only a few Umayyad soil layers in C.7, in the south sector of the Square (Loci C.7:46, 48 and C.7:61).

In previous seasons Umayyad loci were found concentrated in the northwest sector of C.7, in the south and southwest sector of C.3, and in the south sectors of C.2 and C.1. The concentration in C.7 was in soil Layers C.7:25, 38, 40-42, and that in C.3, in soil Layers C.3:23, 27, 50, 55, 56-58; in Wall C.3:48, which projected north out of the south balk; and Wall C.3:24, which ex-

tended out of the east balk in the south sector. An Umayyad surface (C.3:25) was attested in the northeast sector. C.2 in its south sector evidenced soil Layers C.2:12, 13, and Wall C.2:10 located in the southeast corner. The south sector of C.1 attested rocky soil Layers C.1:16, 23, and 32, and Wall C.1:7, an 8.00-m.-long wall reused as part of a retaining barrier for the deep dump of Ayyūbid/Mamlūk times. A few Umayyad soil layers (C.1:20, 34, and 35) were uncovered in the north sector of C.1. No evidence for the Umayyad period was attested in C.5 or in Area G.6, 7, and 9.

There was no numismatic evidence for this period.

Interpretation: The evidence for Stratum VI in Area C.1, 2, 5, and 7 comprised ceramic remains and a few walls, all being considerably sparse. This evidence indicated that the habitation was slight. The function of Wall C.2:10 was not clear, and there was no certainty that it was connected with Wall C.1:7, which seemed to have been reused as a retaining wall at least in the Ayyūbid/Mamlūk period. The soil layers dated to the period appeared to be dump or erosion deposits from clearing operations or from the gradual decay of minor undiagnosed structures.

Other comparable Umayyad habitation on the *tell* was that seen in the Umayyad reuse of the Byzantine Floor D.1:33/34 = D.5:11 and in the room built comprising Walls D.9:15 = D.5:9, D.1:24 = D.6:54 butting up against the acropolis perimeter wall on the south and against the south wall of the Byzantine church on the north.⁵

Strata VII-XIV: Byzantine (ca. A.D. 324-661)

Description: Additional evidence of Byzantine Strata VII-XIV was attested in Area C.1, 5, and 7 in 1976.

Though there were no Byzantine architectural remains found in C.7 in 1976, there were a number of loci uncovered in Byzantine Strata VII-XIV. Early Byzantine soil Layers C.7:47, 49-52, 55-58 (Strata IX-XIV, A.D. 324-450) were found just above and on the east and west sides of the Iron II/Persian Wall C.7:44, and more generally there were Byzantine materials uncovered in the further clearing operations in C.7:70 and 71 in the sector farther east of Wall C.7:44 and in the rock formation there (C.7:53) that seemed to be a platform. Soil Layer C.7:63, in the sector east of Wall C.7:44 was dated to the Late Byzantine Strata VII-VIII (ca. A.D. 450-661), as was also C.7:77, a soil layer in the southwest sector east of the lintel and doorway and before the entrance to Cave C.7:86. Late Byzantine Stratum VII (ca. A.D. 614-661)

⁵ Geraty, "Heshbon 1973: Area D," p. 188.

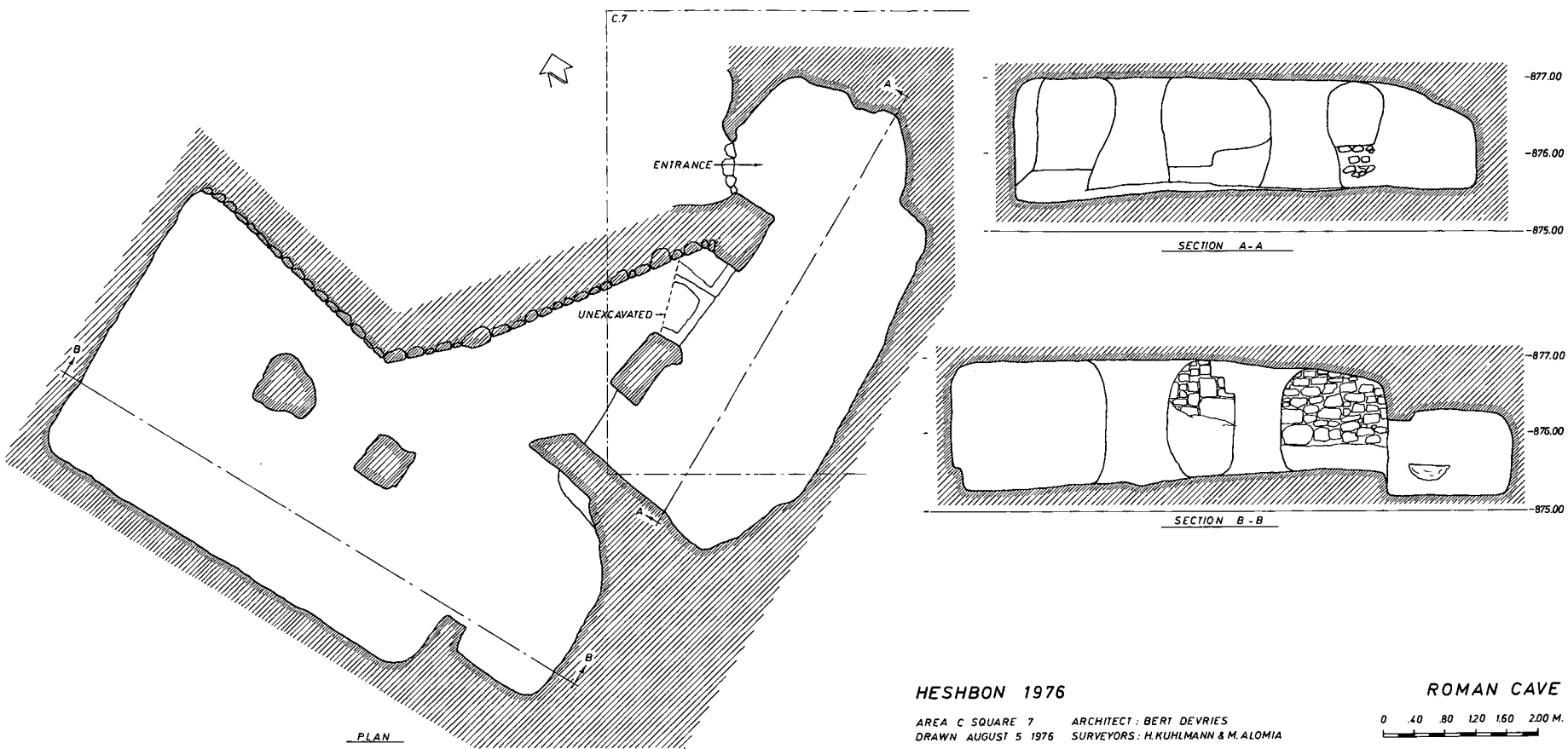

Fig. 6. Plan and sections of Late Roman Cave C.7:86 (Strata XV-XVI).

was attested inside Cave C.7:86, in soil Layer C.7:90 in the hallway between rooms 1 and 2, and in C.7:101, the material that had evidently fallen and sifted into room 3 of Cave C.7:86. In probing into the rock platform (C.7:53) east of Wall C.7:44, further evidence of Byzantine Strata VII-XIV was found in soil Layers C.7:92 and 93, and a more specifically Early Byzantine stratum was in the soil and rock layer, Locus C.7:91, of the platform.

There was no evidence of Byzantine Strata VII-XIV in the 1976 excavation in C.1, but C.5 did produce such evidence. Soil Layer C.5:120, west of Doorway C.5:199 at the corner of the subsidiary south balk and the west balk, was Byzantine. Late Byzantine Stratum VII (ca. A.D. 614-61) was attested in the dump-erosion deposit Loci C.5:167, 169, 174, 176, 177, and 181 in the south sector of C.5, as well as in the soil layers (C.5:188 and 191) of the probe that exposed Wall C.5:190 in the southwest sector of C.5. The wall extended from its north end at the tower Doorway C.5:199 south into the south balk. This probe also exposed Pavement C.5:202 west of the south doorpost of C.5:199.

Early Byzantine Strata IX-XIV (ca. A.D. 324-450) were attested in C.5 within the tower (soil Layers C.5:90 and 91), in soil Layer C.5:96 in the tower's doorway, in the soil layers (C.5:115 and 116) west of the doorway and south of Wall C.5:82, in soil Layers C.5:92, 100, 106 north of Wall C.5:82 and west of Wall C.5:77; and also in the possible foundation Trench C.5:95 for Wall C.5:77, which was part of the west wall of the Tower. In the south sector of C.5 Early Byzantine strata were encountered in the yellow-brown soil layer (C.5:195) over Pavement C.5:202 just to the west of Wall C.5:190; and also in the probes of rock and dirt removed from the sector south of the interior Wall C.5:200 (extending east from the tower's doorway to the east balk) and east of the tower's exterior Wall C.5:190 (extending from the doorway south to the south balk). In this sector soil Layers C.5:198, 203, 204, and 208 south of Wall C.5:200 showed Early Byzantine evidence, as did also soil Layer C.5:201 in the same sector, though Late Byzantine might have been attested in this latter locus. In the same sector soil Layers C.5:209, 210, 215-17, 219-22 and Surfaces C.5:212 and 214, as well as Locus C.5:211 west of Wall C.5:190, were also Early Byzantine. C.5:211 showed Early Byzantine II-III, C.5:215-17, 219-21 Early Byzantine I-II, and C.5:214 and 22 Early Byzantine I.

In previous seasons' work in Area C.1, 2, 3, 5, and 7, Byzantine Strata VII-XIV were attested in the Byzantine wall (C.1:8) that extended southeast to the south balk, in the water channel (C.1:15) that extended southwest into the south balk, and in the fragmentary walls in the northeast sector (C.5:7, 11 and 55). It had been conjectured that Wall C.5:11, represented by a large rock protruding from the east balk of C.5, 1.42 m. south of the northeast corner, was a continuation of Wall C.1:49, but the latter turned out to be Early Roman. All the other Byzantine loci scattered throughout the Squares were various soil layers (C.1:10, 17, 19, 22, 26, 27, 29, 39; C.2:14, 24; C.3:19, 20, 59; C.5:6, 9, 10, 57, 59, 63, 65, 66, 70, 72, 73, 74, 75, 79, 80, 81; C.7:33).

In Area G.6, 7, 9 there were only a few soil loci of Byzantine date. Byzantine sherds were found in the pits at bedrock in G.6 (Loci 20, 21 a and b) and in G.6:30 around and under the lowest course of Wall G.6:8 at bedrock. G.7:5, a soil and rock tumble layer between Walls G.7:4, 6 and 7, did indicate Byzantine deposit there.

Interpretation: The evidence from the Byzantine Strata VII-XIV in Area C.1, 2, 3, 5 and 7 suggested that there were no major independent structures which remained intact here. As has been noted above, not only was the whole Byzantine period (Strata VII-XIV) represented, but also Late Byzantine, Stratum VII (ca. A.D. 614-61) and Early Byzantine Strata IX-XIV (ca. A.D. 324-450) were separable in C.7 in particular.

A coin (unpublished coin [registered object 2940], A.D. 343-50, Stratum XIII) was found in C.5:219 (at the south balk of C.5), a locus in the lower part of the large Byzantine tumble within the tower of C.1 and C.5. This would argue that a large part of the Byzantine tumble in Area C.1 and 5, and particularly that which fell inside the tower, occurred during the A.D. 365 earthquake (Stratum XI). The pottery evidence from C.5:219 showed Early Byzantine I-III (Strata XII-XIV), as did Loci C.5:214-17 and C.5:220-22, which could have meant that all of the debris above C.5:214 tumbled in later at the time of that earthquake (Stratum XI). The fact that the earth Surface C.5:212 (an Early Byzantine locus) sealed over the top of the cistern (C.5:228) located south of Wall C.5:200 between it and the C.5 south balk, indicated that the cistern went out of use in the Early Byzantine period.

Besides the Byzantine rubble that had tumbled into the Early Roman tower, there was evidence that the western part of the tower complex had undergone at least a rebuilding phase in the Early Byzantine period. In the soil under the top surviving course of Wall C.5:77, which ran south from the east-west Early Roman Wall C.5:60, came a four-spouted Early Byzantine lamp. This evidence meant either that this portion of the tower was reused or rebuilt in Early Byzantine times or that Wall C.5:77 was a newly built extension in the Byzantine period. That C.5:95 just west of Wall C.5:77 could have been this wall's foundation trench lent further credence to the view that Wall C.5:77 was either newly constructed or underwent extensive rebuilding in the Early Byzantine period (see Pl. VI:A, B).

There was no absolute proof that Early Byzantine Wall C.1:8, which extended from the west balk of C.1 southeast to the south balk and which seemed to have been part of a retaining wall on the western slope of the *tell*, had any connection with Wall C.5:7, which extended out of the east balk of C.5 at about the same level (ca. 875.25 m.) as C.1:8, since the pottery connected with C.5:7 included Umayyad material. However, although there was no foundation trench discernible for Wall C.5:7, it was noted that just below this wall there was a sandy layer (C.5:10), Early Byzantine in date, which could have been laid down as footing for Wall C.5:7.

In C.7 the Early Byzantine layers just above and on the west and east sides of the Iron II/Persian Wall C.7:44 suggested that this wall was retained in use and/or abandoned as late as the Early Byzantine period.

The presence of two Byzantine sherds on the floor in the entrance of Cave C.7:86 where the evidence was mainly Late Roman may have been an indication of contamination, since materials had fallen in from outside the mouth of Cave C.7:86 when it was opened. Late Byzantine Stratum-VII sherds in the soil layer (C.7:90) in the hallway between rooms 1 and 2 of Cave C.7:86 may have been contamination, also, since this locus was under a loose layer that seemed to have sifted in from an opening to the cave at its south end (a large boulder had fallen in there with the sifted material). The same was no doubt true of the Byzantine pottery in C.7:101 material which had evidently fallen into room 3 at the south end of Cave C.7:86 from this same opening above room 3.

The evidence for Byzantine Strata VII-XIV in Area C correlated with the Late Byzantine of Area D, Pavement D.5:42 and the foundation trench for the church's south wall (D.5:12); with the Early Byzantine plaster, soil layers, and rock tumble layer of Area B;⁶ and with the Early Byzantine church phases in Area A.⁷

⁶ L. G. Herr, "Heshbon 1974: Area D," *AUSS* 14 (1976): 85.

⁷ B. Van Elderen, "Heshbon 1968: Area A," *AUSS* 7 (1969): 156-164.

Strata XV-XVI: Late Roman (ca. A.D. 135-324)

Description: Additional remains of Late Roman Strata XV-XVI were evident in Area C.5 and C.7 in 1976.

There were no architectural remains of the Late Roman Strata XV-XVI attested in 1976 except for the hewn cave C.7:86 and possibly Wall C.5:82, which was west of the Roman tower entrance. Probes into the north face of Wall C.5:82 showed a Late Roman II-III (ca. A.D. 160-250) construction date.

There were a number of Late Roman soil layers attested in C.7 and C.5. Late Roman loci were attested in C.7, particularly in layers east of the Iron II/Persian Wall C.7:44, the platform farther east, in the south sector in layers east of the lintel doorway (C.7:81) leading east to the bedrock Cave C.7:86, as well as in the cave itself. The Iron II/Persian Wall C.7:44 had been bonded on its east to what seemed to be a stone platform, and in Locus C.7:67, near to the bedrock, Late Roman III-IV (ca. A.D. 193-324) ceramics were attested. Beneath this locus, in C.7:80 directly over bedrock, Late Roman was also attested.

Several Late Roman loci were located in uncovering the lintel doorway (C.7:81) which lay at the south end of Wall C.7:44. This led to the conclusion that the Iron II/Persian Wall either had been cut later for the lintel doorway or had originally ended there and the lintel doorway added. In any case in the layers beneath the lintel itself (which was in the southwest corner of C.7) and in the sector east of the lintel doorway which led to the entrance of Cave C.7:86 a number of Late Roman soil loci appeared. They represented Late Roman I-IV as follows: C.7:66, Late Roman III-IV (Stratum XV, ca. A.D. 193-324); C.7:68, Late Roman I-II (Stratum XVI, ca. A.D. 135-93); C.7:77, Late Roman I-IV; C.7:78, the sill over bedrock, Late Roman I; C.7:83, Late Roman I-II; C.7:104 over bedrock, Late Roman I. These loci were supplemented by two Early Roman loci: C.7:84 (Early Roman III, Stratum XVIII, ca. A.D. 20-70) located near the mouth of the cave; and C.7:103, Early Roman II-III (Stratum XVIII, ca. 31 B.C. - A.D. 70) found east of the lintel doorway. Two loci (C.7:64 and 65) found below and just west of the lintel doorway were dated Late Roman III-IV and I-II, respectively.

Cave C.7:86, uncovered in 1976, extended approximately west-east 9.70 m., starting under the south sector of C.7, running east beyond the east balk of C.7 and then south for 7.80 m. The cave consisted of three rooms; the first one (2.50 m. wide) extended west to east 6.00 m. On its east was a limestone wall separating it from a smaller room 2, which was reached through a doorway south of room 1. Also a "hallway" ran east to the entrance to room 2, which room measured about 2.00 m. north-south and about 2.80 m. west-east. This hallway led to a larger room 3 (5.50 m. north-south and from 3.50 m. to 4.00 m. west-east) south of room 2. The cave extended further south of room 1 and the hallway and west of room 3, but it was largely filled up there with some boulders and soil that had fallen and sifted in, evidently from a ceiling collapse or another entrance, visible in a depression, to the south of C.7, which eventually had been filled in to its present ground surface level. Time prohibited the investigation of this accumulation. The floors of the three rooms of Cave C.7:86 were virtually clear of debris except for some

medium sized stones and a thin layer of soil and *huwwar* deposit lying over the bedrock floor surface. In several places there was evidence of carved niches in the walls for small oil lamps. The ceramic evidence pointed to the Late Roman period as the latest period of the cave's occupation. On the floor of room 1 (Locus C.7:88) was found a ribbed jar (object 2739, complete except for its top) which was dated Late Roman I. Ceramic evidence from soil Layer C.7:95 just south of room 2 also proved to be Late Roman, as well as that of Locus C.7:102 (Late Roman I) in room 3. So, too, was Locus C.7:89 in the cave's hallway and Locus C.7:87 (Late Roman III-IV) just inside the main entrance to the cave. Two Byzantine sherds were found in C.7:88, but this was considered contamination since this locus was near the cave's main entrance, into which some extraneous material had fallen when the cave was opened. The Late Byzantine Locus C.7:90 found in the east end of the cave's hallway between rooms 1 and 3 was also contamination since it was found under the loose soil that had fallen in at the south end of the cave. The cave also produced two loci dated Early Roman (C.7:94, Early Roman III-IV, over bedrock in room 2; and C.7:107, Early Roman II-III, on the shelf south of room 1).

Late Roman loci were found in 1976 in several sectors of C.5. In the north-west sector, west of Wall C.5:77 (which ran south from its connection with the Early Roman Wall C.5:60) and north of Wall C.5:82 (which extended west from Doorway C.5:199 at the south end of Wall C.5:77), there appeared several Late Roman soil layers and surface. Surface C.5:108 (Late Roman II-IV); soil Layers C.5:125 (Late Roman III-IV), C.5:128 (Late Roman II-IV), and C.5:133 (Late Roman I-II); Surface C.5:137 (Late Roman); soil Layers C.5:140, 141, 143 (Late Roman III-IV), C.5:154 (Late Roman I-II); Wall fragment C.5:186 (Late Roman II-III), the north face of Wall C.5:82, were all below the probable foundation trench (Locus C.5:95) for Wall C.5:77, which trench was Early Byzantine.

West of Doorway C.5:199 the sector extending to the west balk between Wall C.5:82 on the north and the subsidiary south balk also included a number of Late Roman soil layers: C.5:120, 127 (Late Roman); C.5:121 (Late Roman II-III); C.5:122, 124, 126 (Late Roman III-IV); and C.5:135 (Late Roman I-II).

Late Roman soil layers were also encountered in the south sector of C.5. The whole sector south of the subsidiary south balk to the main south balk and from the east to the west balks measured 5.90 m. east-west on its south side, 5.81 m. east-west on its north side, 2.77 m. north-south on its east side, and 3.54 m. north-south on its west side. This included a stairway cut on the west balk at the southwest corner for use by the crew. This sector was excavated in 1976 almost from the current ground surface down to bedrock at the south balk, a mean depth of 7.00 m. In this south sector of C.5, in that part south of Wall C.5:200 and extending east across the tower interior from Doorway C.5:199, lying east of Wall C.5:190 (running south from Doorway C.5:199), several Late Roman soil layers were uncovered below the heavy concentration of Ayyūbid/Mamlūk and Byzantine materials at a depth of ca. 6.00 m. down from the ground surface. These Late Roman loci were: Surface C.5:223, upon which Wall C.5:190 was possibly laid (Late Roman IV); soil Layers C.5:224 (Late Roman I-II); and C.5:225, 226 (Late Roman II-III).

The lowest locus in this sector at the south balk, just over bedrock at 870.64 m., was soil Layer C.5:227, which yielded Early Roman II-III sherds. This locus was below the founding level of Wall C.5:190.

In previous seasons Area C.5:1, 2, 3, 5, 7 produced few Late Roman walls and soil layers. Late Roman Wall C.1:12, at the southeast corner of C.1, extended into the south and east balks of C.1. It was probably connected with the rocky Locus C.2:29 in the west balk of C.2. In that Square several Late Roman soil layers (C.2:25, 29, 30, 45, C.3:31, and C.5:8) were attested, but that was about all.

There were no Late Roman materials found in G.6, 7, or 9.

Interpretation: The evidence presented above argued for considerable human activity in Areas C.5 and C.7 in the Late Roman period generally and in Late Roman III-IV in particular. Cave C.7:86 evidenced its latest occupation to be Late Roman III-IV, although two Early Roman loci within the cave may have indicated an earlier use of the cave as well. The entranceway to the cave, in the sector from lintel Doorway C.7:81 east to the cave, also showed the latest habitation to be in Late Roman III-IV. Wall C.7:44 and the platform to its east also seemed to have been in use in that period.

In Area C.5 the number of Late Roman loci, as late as III-IV, west of Wall C.5:77, north of Wall C.5:82, and below the level of C.5:77's probable foundation trench (Early Byzantine Locus C.5:95), argued for an earlier occupation in that sector before Wall C.5:77 was built or rebuilt in Early Byzantine times.⁸ That there was a wall earlier than Early Byzantine in the location of Wall C.5:77 was indicated by the fact that Late Roman Wall C.5:82 (a Late Roman II-III wall extending west) must have extended west from the end of such a wall and the adjoining Doorway C.5:199. The Late Roman I-IV loci south of Wall C.5:82 and west of it in front of Doorway C.5:199 argued for the same conclusion.

Also the Late Roman loci, as late as IV, in the south portion of the tower argued for an earlier occupation than Early Byzantine.

⁸ See discussion above, p. 58.

This evidence of the Late Roman period corresponded to the Late Roman occupation attested in the use of the stairs in Area D,⁹ the plastered layers in Area B,¹⁰ the well-constructed wall (in Squares A.7 and 9), and the platform stylobate wall (in Square A.6), that rested on the acropolis bedrock.¹¹

Strata XVII-XIX: Early Roman (ca. 63 B.C. - A.D. 135)

Description: Additional remains of Early Roman Strata XVII-XIX were evident in Squares C.1, 5, and 7 in 1976.

In a probe into the foundation trench (C.1:110) just north of Wall C.1:49, the latest ceramics read at its bottom showed Early Roman I (Stratum XIX), although some Iron I A or B sherds in the lower layers of the trench backfill evidenced some mixing when the Iron I material had been dug through to lay the foundation for the Early Roman wall. Other Early Roman loci (C.1:123 and 125, both Early Roman I-II) were found in a probe of soil and rocky layers down to bedrock in the northwest sector of C.1, lying north of Wall C.1:49 and extending all the way to the north and west balks.

In C.7 Early Roman strata were attested by soil Layers C.7:69 and, lower, C.7:76 (right over bedrock) in the sector between Wall C.7:44 and the west balk. Just north of Doorway C.7:81, down at bedrock, was another Early Roman locus (C.7:79), the possible foundation trench for the doorway construction. An Early Roman III soil layer (C.7:84) was attested at the mouth of Cave C.7:86, and Early Roman II-III soil layers (C.7:85 and 103) were found in the sector between Doorway C.7:81 and the cave. Over bedrock in room 2 of the cave, soil Layer C.7:94 was Early Roman III-IV, and soil Layer C.7:107, on the shelf west of room 1, was Early Roman II-III. As has been mentioned, these Early Roman loci in and at the mouth of Cave C.7:86 may have indicated an earlier use of the cave than that in the Late Roman Period.

During the 1976 season C.5 yielded a number of Early Roman soil layers, several of which were in the sector west of Wall C.5:77 and north of Wall C.5:82. This was true of the Early Roman soil Layers C.5:157 and 175, and of Early Roman II-III soil Layer C.5:165. In the extreme northwest corner of C.5, along the stairs and the west balk, soil Layer C.5:16 was dated Early Roman I-II. Just west of the tower Doorway C.5:199 and south of Wall C.5:82 lay Early Roman soil Layer C.5:179 under Byzantine soil Layer C.5:178 and over Iron I A or B soil Layer C.5:173.

Within the tower, possibly running under Wall C.5:60 on the north and bounded by Wall C.5:77 on the west, Wall C.5:200 on the south, and the east balk, was the hard yellowish Surface C.5:102, which lay at a level 0.20 m.

⁹ Herr, "Heshbon 1974: Area D," p. 87.

¹⁰ Sauer, "Heshbon 1974: Area B and Square D.4," p. 44.

¹¹ Van Elderen, "Heshbon 1974: Area A," *AUSS* 14 (1976): 28.

below the bottom course of Wall C.5:60 on its south side. This surface was left unexcavated except for a small probe (C.5:213) in the northwest sector near the conjunction of Walls C.5:77 and C.5:60. Right under Surface C.5:102, soil Layer C.5:213 attested Early Roman.

Further evidence of the Early Roman period in C.5 was found at the south balk below and east of Wall C.5:190, where soil Layer C.5:227, just over bedrock, was dated Early Roman II-III.

Previous seasons of work in Area C produced considerable evidence for the Early Roman period, particularly in C.1 and C.2 (some in C.5).

Because of its deeper founding, Wall C.1:13, which ran north-northeast about 1.30 m. west of the east balk to the stairs, could be considered constructed somewhat earlier than Walls C.1:37 and C.1:14; a coin (object 49, Aretas IV, 9 B.C. - A.D. 40) found in soil Layer C.1:41, which extended over Wall C.1:13 and under *huwwar* Surface C.1:39, indicated that Stratum XVIII was the earliest to be posited for construction of Wall C.1:13. Wall C.1:37 ran perpendicular to and abutted Wall C.1:13 at its southern end, a fact that suggested that these two walls (C.1:13 and C.1:37) were part of an Early Roman structure. Wall C.1:37 ran at a slight angle to Wall C.1:14, which extended west from the east balk 4.45 m. and had *huwwar* Surface C.1:36 and 39 (traced primarily in the east balk) running up against it. This wall, C.1:14, has been suggested as the latest Early Roman construction in C.1, with Walls C.1:13-C.1:37 built slightly earlier;¹² it extended west almost to the north end of Wall C.1:40. There were also other Early Roman soil layers in this Square (C.1:46, 50, 56, 64, 65, 67-70, 73, 75, 77-81, 101, 104, 105, 113-17).

A soil layer (C.1:54, 61, 62) from 0.75 m. to over 2.00 m thick (at the south balk) lay under the three walls mentioned above and partly up against Walls C.1:40 and 63.

The second group of important Early Roman walls in C.1 was attested in the west sector of the Square. This included Wall C.1:40 (and its Early Roman foundation Trench C.1:38) which extended north from the south balk and was joined by a north extension in C.1:63 (with its Early Roman foundation Trench C.1:73), all of which was bonded to Wall C.1:49 (with its Early Roman foundation Trench C.1:110), which wall extended west into the west balk and into Square C.5 as Wall C.5:60. North of the bond of Walls C.1:63 and C.1:49 ran the additional Wall fragment C.1:30, (with its Early Roman foundation Trenches C.1:109, C.1:111).

To the west, in Square C.5, all that had been found of the period were Early Roman Wall C.5:60 (and its Early Roman foundation Trench C.5:62) and Wall C.5:77, also presumed to be Early Roman when first found.

Uphill east in Square C.2, Early Roman strata were evident in the soil layer (C.2:27) between Iron Age Wall C.2:26 (which ran northwest out of the east balk near the southeast corner of C.2) and the north balk, and in soil Layers C.2:34 (which covered most of the Square) and C.2:15 in the northwest corner of C.2. Also Early Roman were the fill layers (C.2:32, 37) of a pit in the southwest corner of the Square, together with the pit lining (C.2:36) and the Early Roman soil layer (C.2:42) on its south face. Wall

¹² Thompson, "Heshbon 1971: Area C," *AUSS* 11 (1973): 84.

C.2:38 (with its Early Roman foundation Trench C.2:33) was a stub extending east from the west balk about 3.50 m. north of the south balk. It appeared to be the eastern segment of Walls C.1:14 and C.1:37. There was also an Early Roman soil layer, C.2:27, in the south part of C.2, as well as rock tumble C.2:28.

Interpretation: In Square C.7 the presence of several Early Roman loci in the entrance way to Cave C.7:86, as well as in the cave itself, suggested the possible use of the cave earlier than in the Late Roman period. Also, Early Roman loci west of the Iron II/Persian Wall C.7:44 and over bedrock there suggested that Wall C.7:44 was in use in the Early Roman period.

The presence of a thick soil layer between the walls of Square C.1 suggested that three stages were represented there in the Early Roman period: a) a late stage of Early Roman, possibly Strata XVII-XVIII (31 B.C. - A.D. 135) comprising Wall C.1:14 (with its extension east into Square C.2 as Wall C.2:38) and *huwwar* Surface C.1:36 and 39, together with Walls C.1:37 and 13; b) an intervening heavy soil layer (C.1:54, 61, 62); and c) an earlier Early Roman Stratum (XIX) comprising Walls C.1:40, 63, 49, 30. This Early Roman Stratum XIX was seen also in the westward extension of Wall C.1:49 as C.5:60 with its Early Roman foundation trench (C.5:62) on its north face. This complex in C.1 and C.5 comprising Walls C.1:40, 63, 49, C.5:60 seemed to have been part of an Early Roman defense tower (see Fig. 11, p. 64, in 1974 Area C report).

That there was Early Roman habitation south of Wall C.5:60 can be argued from Probe C.5:213 under the yellow Surface C.5:102 within the tower, and from Locus C.5:227 (Early Roman II-III) just over bedrock at the south balk. But just when the west wall of the tower (C.5:77 and C.5:190) was built or rebuilt is another question. Roman II-III pottery coming from Locus C.5:186, the north exterior face of Wall C.5:82, suggested that this wall, extending west from C.5:77 and Doorway C.5:199, was built in Late Roman times.

The evidence of an Early Byzantine foundation trench (C.5:95) on the west face of Wall C.5:77 and the Early

Byzantine four-spouted lamp taken from the top course of Wall C.5:77 suggested that this part of the tower complex was rebuilt (possibly for better defense) even later than Wall C.5:82 extending to the west. Since Wall C.5:190 extending south from Doorway C.5:199 seemed to have been founded on Surface C.5:223 (Late Roman IV) and also below C.5:219, where the Early Byzantine Stratum XIII coin (no. 2940, A.D. 343-50) was found, it was argued that this Wall C.5:190 was probably built in the Late Roman IV period. It may be that the Early Roman (Stratum XIX) tower as a whole suffered extensive damage and needed repairs on its downhill side in Late Roman and Early Byzantine periods before the destructive earthquake of A.D. 365.

All these Early Roman loci in C.1, 5, and 7 correlated with similar loci in Area B (Stratum XVII, plaster layers)¹³ and Area D (Stratum XVII, the ramp, and Stratum XVIII, the fill under the ramp, and the cistern).¹⁴

Strata XX-XXI: Hellenistic (ca. 250-63 B.C.)

Description: Additional remains of Hellenistic Strata XX-XXI were attested in Area C.5, C.7 in 1976. There were, however, no Hellenistic structures found; only pottery fragments in a few soil layers.

In the northeast corner of Square C.5, soil Layer C.5:163, which ran along foundation Trench C.5:136, produced two Hellenistic sherds in otherwise Iron II and Iron I material. In the northwest corner of C.5 one Hellenistic sherd was found. The evidence of Hellenistic habitation was indeed sparse in C.5.

Soil Layer C.7:60 in the northwest corner of C.7 produced Hellenistic sherds. The Hellenistic evidence was more concentrated in and around Iron II/Persian Wall C.7:44. Hellenistic materials were encountered in the removal of soil and lower stones (C.7:96, 98) in the platform east of Wall C.7:44, in the fire-pit (C.7:99) cut into bedrock there, and also in the soil (C.7:100) removed under the top surviving course of stones of Wall C.7:44. Just over bedrock in the soil (C.7:97) east of Wall C.7:44, there were Iron Age sherds found. No pottery was found in further probing (Loci C.7:105, 106) both around and under the next lower course of stones of Wall C.7:44.

In previous seasons, a number of Hellenistic loci were identified, all of them being soil layers except for Wall C.2:49 in the southeast corner of Square C.2, where Hellenistic evidence was found in an otherwise Iron Age locus.

¹³ Sauer, "Heshbon 1974: Area B and Square D4," p. 52.

¹⁴ Herr, "Heshbon 1974: Area D," pp. 92-96.

Square C.2 also contained Hellenistic soil Layer C.2:31 (a hard packed layer in the south part of the Square), Fire-Pit C.2:46 in the central sector, and soil Layer C.2:48 in the southwest sector. Square C.3 yielded Hellenistic soil Layers C.3:35, 36, 37 in the northwest sector and ash Pit C.3:29 in the southwest part of the Square.

Square C.1 attested a concentration of evidence for Hellenistic strata in C.1:76, a soil Layer which sloped down from the east balk westward, and in soil Layers C.1:85-89, 92, 93, and 96, in the southeast sector of the Square.

There were no Hellenistic strata evidenced in Area G.6, 7, or 9.

Interpretation: The relatively few Hellenistic loci uncovered in Area C.1, 2, 3, 5, 7 over the various seasons, with no certain architectural remains, argued for a sparse occupation in the Hellenistic period. Only in the southeast sector of Square C.1 near bedrock is there even a meager concentration of evidence for the Hellenistic Strata XX-XXI. It may be suggested that nomads or shepherds camped here but put up no permanent dwellings.

More settled occupation nearer the acropolis may be attested in the Hellenistic use of the caves (B.4:74, 171, and 247) and the cisterns there, as well as the pool (B.4:265) in Area B,¹⁵ and in the threshing floor in Area D.¹⁶

Stratum XXII: Iron II/Persian (ca. 800-500 B.C.)

Description: Additional remains of Iron II/Persian Stratum XXII were attested in Area C (C.5 and possibly in C.1) in 1976, but no additional structures were found.

In Square C.1 soil and rock Layer C.1:122 showed Iron II/Persian remains, with Ayyūbid/Mamlūk and Byzantine contamination from between-season erosion.

In the northeast corner of Square C.5, in the sector between Wall C.5:60 and the north and east balks, several Iron II/Persian loci were identified: C.5:86, 105, 110, 112, and 119—some loci being of soft soil and some of hard clay and pebbles, a mixture indicating debris washed or blown in. The deep probe along the west balk of C.5 was a layer of soil and stones; C.5:196, a mixed Iron I-II locus.

In previous seasons a number of Iron II/Persian loci were attested in C.1, C.2, C.3 and C.7. In the south sector of C.1, Wall C.1:90 entered the east balk not far from the southeast corner of the Square and was continued in C.2 as Wall C.2:52 - C.2:90, which ran east and then south into the south balk of C.2. This wall's foundation trench cut into the *huwwar* material (C.2:73, 83 and probably C.2:92, 94, 96, 98). As has been noted, many of the loci excavated in 1974 in the south sector of Square C.2 were considered dump material

¹⁵ Sauer, "Heshbon 1974: Area B and Square D4," pp. 55-56.

¹⁶ Herr, "Heshbon 1974: Area D," pp. 97-98.

from 8th-6th century B.C. occupation.¹⁷ In addition to the material in the south sector of C.2, there were dated to the same period: Loci C.2:51, a possible pit in the northeast sector of C.2; C.2:40 and 47 toward the center; C.2:41, 44 in the southeast; and C.2:45 and 50 in the southwest sector.

An Iron II/Persian zigzag wall was traced over several seasons in Area C.2, C.3, and C.7. Wall C.2:26, which entered the east balk of C.2 about 1.25 m. north of the south balk, continued into C.3 as Wall C.3:26 - C.3:60 and turned south into the C.3 south balk to become Wall C.7:44 as it ran south in C.7. Wall C.3:34 was made of massive boulders founded on a shelf cut into bedrock in the south sector of C.3 and on its east abutted the stone Wall C.3:28. It may also be a part of this zigzag wall, as may be Wall C.3:28, which entered the east balk of C.3 about 3.00 m. north of the south balk to become what seemed to be a part of Wall C.5:45 as it extended east-southeast 3.50 m. into C.4. Wall C.7:44, which was founded on bedrock, continued south in C.7 either until it stopped or until it was cut to make room for the Late Roman lintel doorway (C.7:81) to Cave C.7:86 (see Fig. 12, p. 69, in 1974 report).

In C.3 there was Iron II/Persian Wall C.3:32 in the south sector, which was a buttressed wall set on bedrock that abutted against Walls C.3:26 and 34; and Wall C.3:43, a line of large boulders in the trench in bedrock which lay under Wall C.3:32. In the south sector of C.3 a number of Iron II/Persian soil layers were attested (C.3:30, 38-42).

There were no Iron II/Persian loci attested in Area G.6, G.7, and G.9.

Interpretation: The absence of any Iron II/Persian structures in C.5, the single wall (C.1:90), in C.1; the presence of only a number of Iron II/Persian soil layers in C.5 (particularly in the northeast sector, with one in the west sector, C.5:196), and one in C.1 (C.1:122) suggested meager Iron II/Persian occupation, if any, this far down on the west slope of the *tell*. Rather in this sector the Iron II/Persian soil and rock material may have been dumped or washed down.

In contrast a major defense perimeter seems to have been built farther up on the slope, as evidenced by the zigzag wall in Squares C.2, 3, 4, and 7. It may be that this occurred because a smaller and higher portion of the *tell* would be more easily defended in this period. As noted above, the Iron II/Persian wall which was continued south from C.3 as Wall C.7:44 either stopped, or was cut off, in the south sector of C.7, and the Late Roman lintel doorway (C.7:81) and the entrance way to Cave 7:86 was put in later. Because of the lack of any Iron II/Persian loci attested on either side of or within the two upper surviving

¹⁷ Mare, "Heshbon 1974: Area C," pp. 67-68.

courses of Wall C.7:44, it may be concluded that this portion of the Iron II/Persian wall in C.7 had been rebuilt or altered in Roman times. It is of note that the lower courses of Wall C.7:44 look rough and unhewn, like parts of this wall in Squares C.2, 3, 4, but two or three stones of the top course in Wall C.7:44 looked somewhat worked.

This evidence for Iron II/Persian in Area C can be correlated to Wall D.2:84 and the reservoir found in Area B.¹⁸

Stratum XXIII: Iron II (ca. 10th to 9th Century B.C.)

Description: Remains of Iron II Stratum XXIII were attested in Area C.5 in 1976. Only soil layers were found, however, all in the north sector of Square C.5.

In the northeast sector of C.5, north of Wall C.5:60, Iron II layers were identified including C.5:109 (a sedimentation layer or thin occupation layer of hard red clay with *huwwar*), C.5:129 (a layer of soil with pebbles and *huwwar*) and C.5:163 (another pebbly layer).

In the northwest sector of C.5 near the access stairs were found: C.5:144 (a layer of pebbly soil) and C.5:180 (a layer of soil and small stones). An isolated Iron II Layer C.5:130 (of soil and *huwwar* flecks) was found west of the tower Doorway C.5:199.

There was no evidence of Iron II found in previous seasons in Area C.1, C.2, C.3, C.7 and Area G.6, G.7, G.9.

Interpretation: From the paucity of Iron II loci attested in Area C it can be concluded that there was little or no habitation in this period on this part of the *tell*. Debris recovered seems to have been eroded or dumped into place.

Stratum XXIV: Iron I (ca. 1200-1000 B.C.)

Description: Additional loci of Iron I Stratum XXIV were attested in Area C (C.1, C.5) in 1976, but no Iron I structures were found.

In previous seasons in Area C there was differentiated only the general period of Iron I, which was attested only in the south and center sectors of C.1 in soil Layers C.1:60, 95, 97-99, and 100 (red-brown soil and *huwwar* over bedrock).

Loci uncovered in C.1 and C.5 in 1976 allowed a refinement in the differentiation of phases within Stratum XXIV, phases distinguishable progressively earlier as the deeper material was dug. The latest of these phases was considered Iron I C/II A identified as C.1:147 (a soil layer in the northeast sector); as C.5:187 (a layer of soil and stone west of the tower entrance C.5:199) and as C.5:206 (along the west balk north of Wall C.5:82). Also of this phase was Iron I B/C-II A (C.5:215, a stony soil layer in the probe at

¹⁸ Sauer, "Heshbon 1974: Area B and Square D.4," pp. 57-59.

the west balk), also Iron I B/Iron II (C.1:155, a soil layer in the northwest sector of C.1).

Slightly earlier was an Iron I B/C stage represented by soil Layers C.1:124, (in the northwest sector); C.5:152, 194 (in the northeast sector); and C.5:189, 192, 193, 205, 206 (in the northwest sector).

Still earlier was Iron I B, attested in the northwest sector of C.1, north of Early Roman Wall C.1:49, by Loci C.1:126-130; also in the northeast corner of C.5 by C.5:155 and 171; and in the northwest sector by C.5:159 and 168.

Earlier still was phase Iron I A/B, represented in the northwest sector of C.1 by the soil and stony Layers C.1:132, 136-140, and 141. In C.5 Iron I A/B was attested in the northeast corner by C.5:172 and C.5:183, in the northwest sector by C.5:164, and in the entry way west of Doorway C.5:199 by C.5:173.

Iron I A, aside from one pebbly soil layer, C.5:184, found west of the tower doorway (C.5:199), was attested only in the northwest sector of C.1 in layers of soil, clay, stones, and charcoal (C.1:131, 133-35, 142, and 143) with C.1:144 on bedrock including only one body sherd.

Interpretation: From the lack of any Iron I structural remains in Area C it was concluded that there was no significant habitation on this part of the *tell*. From the presence of layer upon layer of Iron I soil and stony material in C.1 and C.5, mixed at times with clay and charcoal, it was concluded that Iron I material was filled or dumped here from elsewhere on the *tell*. In C.1 this Iron I material had been cut into later for the founding of Early Roman Wall C.1:49.

The great quantity of loom weights found in the Iron I layers in the northwest sector of C.1 suggested that this material may have been collected from a work zone higher up on the slope and dumped here.

That there was a deliberate dumping of the Iron I material on this slope was concluded from the somewhat orderly way the loci were evident in the northwest sector of C.1:

Iron I B/C	C.1:124
Iron I B	C.1:126-30
Iron I A/B	C.1:132, 136-41
Iron I A	C.1:131, 133-35, 142-44

Evidence of Iron I in Area C.1 and C.5 can be compared to the Iron I channel of Area B.2 and B.3 and the walls and cobblestone pavement of what would seem to be a domestic occupation in D.4:65, 66¹⁹ and the cistern in D.1.²⁰

¹⁹ Ibid., p. 62.

²⁰ Herr, "Heshbon 1974: Area D," p. 99.

AREA C.4, 6, 8, 9, 10

S. THOMAS PARKER
University of California
Los Angeles, California

The easternmost five Squares of Area C, on the western slope of Tell Heshbân, were my responsibility in 1976. Square C.4, located furthest down the slope to the west, had already been excavated to bedrock in the 1968 and 1971 seasons. Just to the east, Squares C.6 (excavated in 1971 and 1974) and C.8 (also excavated in 1974) were worked throughout the 1976 season.¹ Further up the slope to the southeast two new Squares were opened to link Area C with Area A on the acropolis. These two new Squares were designated C.9 and C.10. Both were worked through most of the season. Square C.10 measured 7.00 m. east-west by 3.00 m. north-south, while Square C.9 measured 7.00 m. east-west by 6.00 m. north-south and was subdivided into two 3.00 x 7.00 m. halves. The northern half was excavated in the normal manner, but the southern half, designated the "Test Square," was excavated in a somewhat different manner.²

The primary objective for the 1976 season in the eastern sector of Area C was to complete a section of the *tell* from topsoil to bedrock along an east-west axis from the acropolis down the western slope. A secondary objective was to elucidate further the Mamlük domestic complex found in C.4, C.6, and C.8 in previous seasons. It was also hoped that some kind of access route leading up to the acropolis could be located, which indeed had been a factor in the original decision to open Area C in 1968.³ To a

¹ For the results of the 1968, 1971, and 1974 seasons, cf. H. O. Thompson, "Heshbon 1968: Area C," *AUSS* 7 (1969): 127-141; id., "Heshbon 1971: Area C," *AUSS* 11 (1973): 72-88; W. H. Mare, "Heshbon 1974: Area C," *AUSS* 14 (1976): 63-78. No Squares of this portion of Area C were excavated during the 1973 season.

² The "Test Square" procedures and results are briefly noted on pp. 10, 14, 241, 242.

³ Cf. Thompson, "Heshbon 1968: Area C," p. 127. At that time the surface topography of Area C suggested a possible ancient gateway.

large extent all these objectives were achieved this season. The major disappointment was our failure to reach bedrock in C.10. The results of this work are described and interpreted here. In addition, the results of the earlier seasons from Area C are presented and fully incorporated into the present report.

Stratum I: Modern (ca. A.D. 1870-1976)

Description: Several modern objects were found on the ground surface, but there was no evidence of any modern stratification.⁴

Interpretation: The objects suggested that there was slight human activity in this sector of the site since the resettlement of Ḥesbân early in this century.⁵ But the complete lack of modern stratification suggests that this portion of the *tell* was not reoccupied by the modern villagers.

Post-Stratum II: Gap (ca. A.D. 1456-1870)

Description: The latest attested pottery was invariably Ayyūbid/Mamlūk, and the latest coin was dated to A.D. 1382-1399.

Interpretation: The complete absence of any pottery, coins, or stratification from the Ottoman or later periods (as over the site generally) strongly implied a sitewide gap in occupation from the Ottoman period onward, as did the absence of any literary references to Ḥesbân.⁶ J. A. Sauer has reasonably argued that a mid-15th century abandonment was related to a "gradual partial depopulation of Transjordan which occurred during the Late Mamlūk and Ottoman periods."⁷

⁴ Cleanup prior to regular excavation included loci C.4:47, C.6:10, 26, C.8:16. The pottery from all these loci was predominantly Ayyūbid/Mamlūk. These loci also produced the following registered artifacts: from C.4:47 a Nabataean coin of Aretas IV (9 B.C. - A.D. 40), object 1018 (hereafter the word object will be omitted), and two glass beads (335, 336); from C.6:10 an iron ring (1770), iron hook (1772); from C.8:16 a Roman millstone (2201), bead (2204), and bronze spatula (2212).

⁵ For a discussion of the modern village and population, cf. Ø. S. LaBianca, "The Village of Ḥesbân: An Ethnographic Preliminary Report," *AUSS* 14 (1976): 189-200.

⁶ For the literary references cf. W. Vyhmeister, "The History of Heshbon from the Literary Sources," *AUSS* 6 (1968): 173.

⁷ J. A. Sauer, "Heshbon 1971: Area B," *AUSS* 11 (1973): 36. But in the

Strata II-III: Mamlūk (ca. A.D. 1260-1456)

Description: All five Squares before excavation were covered by a loose brownish gray topsoil littered with numerous cut and uncut stones—many randomly scattered, but many aligned into several clearly discernible protruding walls, especially in Squares C.8 and C.9. This soil (Locus 1 in each Square) was 0.10 to 0.30 m. deep, badly disturbed by plant roots and animal burrows. It contained large amounts of pottery (the latest uniformly Ayyūbid/Mamlūk), bones, (including sheep/goat, donkey, and cattle), and *mollusca* shells. Numerous objects, mostly small or broken, of stone, iron, bronze, glass, and clay, with two coins, one silver, were dated Ayyūbid/Mamlūk, A.D. 1171-1342).⁸ In all Squares a number of walls lay immediately beneath topsoil.

In the north sector of C.4 and C.6 was found a rather substantial building (called the "north building" in previous reports). Its south wall was a major structure (C.4:2/9 = C.6:2) composed of two roughly hewn masonry faces with an interior of soil and rubble.⁹ Of varying thickness (1.00-1.45 m.), it extended eastward from C.4 through the balk into C.6 for some 8.05 m., preserved up to five courses high in places. Several of the top stones of the inner face tilted northward, probably as the springers of a vaulted roof. Perpendicular to and bonded into this wall on the west was Wall C.4:8/70.¹⁰ This wall, preserved in up to eight courses, extended 1.70 m. into the north balk. The upper courses yielded mostly Ayyūbid/Mamlūk pottery, but few in the lower courses, in which Early Byzantine pottery predominated. Among the objects of Wall C.4:2 was a coin of Justinian I (A.D. 527-565).¹¹ Two entrances were found in the building. One arched doorway permitted access through Wall C.4:2, 9 near the balk between C.4 and C.6. This doorway was secondarily blocked in two stages.¹² The upper (C.4:60) consisted of loose brown soil and neatly laid small stones, with a thickness of 1.06 m.; the lower (C.4:61), of harder, reddish brown soil and small stones, 0.06 m. thick. The pottery from both loci was uniformly Ayyūbid/Mamlūk.

Another entrance was found to the east, between the north face of Wall C.6:2 and Wall C.6:19, which ran from the north balk 0.63 m. southward, and

eastern part of Area C, as will be seen below, the Mamlūk occupation came to an end very shortly after A.D. 1400.

⁸ The Ayyūbid coin (2590) came from C.9:10.

⁹ The locus number C.4:2 was assigned to the exterior (southern) face of this wall; C.4:9 to the inner (northern) face; the whole wall is here designated C.4:2/9.

¹⁰ The exterior (western) face was designated C.4:8; the interior (eastern) face, C.4:70; the whole wall, C.4:8/70.

¹¹ A. Terian, "Coins from the 1971 Excavations at Heshbon" (hereafter as "Coins 1971"), *AUSS* 12 (1974): 38. Originally, it had been ("Heshbon 1971: Area C," p. 74) erroneously reported that Wall C.4:2 produced four pails of Umayyad pottery; actually, the wall yielded *no* Umayyad pottery. Wall C.6:2 was particularly rich in objects, producing several iron nails (2420, 2416, 2498), iron saw blade fragment (2393), bronze earring (2417), basalt rubbing stone (2442), ceramic loom weight (2430), and several glass fragments.

¹² See "Heshbon, 1971," Pl. VII:A.

consisted of two rows 0.84 m. wide. It was preserved to a height of three courses and formed part of the east wall of the building. An interesting feature of this wall was a partially preserved window sill protruding through the north balk. Wall C.6:19 dated Ayyūbid/Mamlūk. In between Walls C.6:2 and C.6:19 was the entrance itself, in the form of a sunken stone-paved threshold (C.6:28) with double door sockets still *in situ* (see Pl. VII:A). Among the registered objects in this Ayyūbid/Mamlūk locus were an iron knife blade fragment (2333), glass ring fragment (2331), and a blue bead (2314).

Attached at a right angle to the outer face of the west wall (C.4:8) of the north building was Wall C.4:10, which ran westward for 1.50 m. before disappearing into the north balk. Preserved to five courses high, this wall abutted Wall C.4:8, and rested on soil Layer C.4:25. Another wall abutting the north building was Wall C.4:15, the north end of which was laid up against the blockage of the south entrance (C.4:60, 61) and Wall C.4:2. Wall C.4:15 was built in two rows of large irregular field stones with chinks, and survived to a height of two courses (0.70 m. high); 1.25 m. wide, it ran southward for approximately 2.50 m. Dated Ayyūbid/Mamlūk, it produced two registered objects, a glass bead (658) and an iron nail (782).

Inside the north building, immediately beneath the topsoil loci, were several subsoil layers (C.4:11, 21, 24; C.6:5, 10, 17), which extended from Wall C.4:9 = C.6:2 to the north balk. These layers were brownish gray or reddish gray, containing many large cut and uncut stones, and some chunks of *huwwar*. The depth of each layer varied from 0.20 to 1.00 m. The latest pottery from all six loci was uniformly Ayyūbid/Mamlūk. All but one of these soil layers produced registered objects, but especially important were two coins. C.4:11 yielded a Mamlūk coin (more precise identification was impossible), while C.4:24 produced another Mamlūk coin dated A.D. 1363-1377.¹³ Beneath C.4:24 and C.6:17 was *huwwar* Floor C.4:26 = C.6:21. This floor, which was laid in very thin layers, measured 6.68 x 2.49 m. at its greatest extent and averaged 0.08 to 0.20 m. in thickness. It touched the north balk and all the inside walls of the building (Walls C.4:9, 70; C.6:2, 19). Included in this Ayyūbid/Mamlūk floor locus was a thin layer of reddish soil immediately under the floor.¹⁴ At the eastern entrance the floor was cut by C.6:40, the foundation trench for Threshold C.6:28. This trench extended from Wall C.6:2 northward to C.6:19, and penetrated through several lower soil layers to a depth of 0.30 m. The latest pottery was again Ayyūbid/Mamlūk, and the trench produced one registered object, a knife blade with its rivet still in place (2332). The floor was also riddled by a complex of animal holes (C.4:41, 47) and by an Ayyūbid/Mamlūk fire pit (C.6:42) filled with charcoal and ash along the north balk. It measured 0.30 x 1.30 m., and its average depth was 0.07 m.

Beneath the *huwwar* floor of the north building a series of four superimposed earth floors appeared (C.4:30, 34, 37, 43; C.6:45, 48, 51, 72), pri-

¹³ Terian, "Coins 1971," object 193, published coin 83. Among the objects in C.6:5 were a basalt grinder (1137), stone weight (1190), iron sickle point (1138), and bronze ring fragment (1189).

¹⁴ Floor C.6:21 yielded the following registered objects: iron nail (2353), and slingstone fragment (2386).

marily composed of hard-packed reddish brown earth and small stones, but also containing considerable *huwwar*, ash, and flat-lying sherds. Floors C.4:30, 34, 37, 43, all extended from the north balk to Wall C.4:9, and all but C.4:43 reached Wall C.4:70 to the west. In C.6, however, the situation was considerably complicated by pits (C.6:50, 73) and animal burrows (C.6:49, 52, 56). Animal Hole C.6:49 was found along the north face of Wall C.6:2, where it had cut through Floors C.6:21, 45, 48. Holes C.6:52, 56 cut through Floor C.6:51 and through Pit C.6:73. Sealed under Floor C.6:45 was Pit C.6:50, which was filled with some debris (small stones, ash, mud brick fragments, and bones) but very little pottery, the latest of which was Early Byzantine. This pit measured 1.72 x 0.19 m. and disappeared into the north balk. Beneath this was another pit (C.6:73) that also extended along the north balk, reached Wall C.6:2, and measured 1.67 x 1.35 m. Its depth was at least 0.50 m., but its bottom was not reached. This was a particularly rich pit, containing large amounts of pottery (Ayyübid/Mamlük the latest), bones, wood and dung ash, glass, shell, and a bone needle (2802).¹⁵

Floor C.6:45 = C.4:30 was a hard, compacted dirt layer filled with ash, charcoal, bone, mud brick fragments, and small pieces of *huwwar*, and averaged 0.13 to 0.15 m. in thickness. It touched inner Walls C.4:70, C.4:9 = C.6:2 but was cut on the east by C.6:40, the foundation trench for the east threshold (C.6:28). It was an extremely rich floor in both pottery and objects. C.6:45 produced an Ayyübid coin dated A.D. 1171-1342 (2472), a Mamlük coin (2469, no date), the base of a glass vessel (2413), and bronze ring with an inscribed silver disc (2453).¹⁶ C.4:30 also yielded an Ayyübid coin (381, dated A.D. 1171-1342),¹⁷ rod (370), and stone pendant fragment (379). The latest pottery was uniformly Ayyübid/Mamlük.

Beneath Floor C.6:45 was *huwwar* Floor C.6:48 = C.4:34 and the makeup(?) layer beneath it. It again reached Walls C.4:9 and 70 and was cut on the east by foundation Trench C.6:40. Measuring up to 0.24 m. thick, this Ayyübid/Mamlük floor was composed of *huwwar*, small stones, ash, and charcoal. It was not particularly rich in bones or objects. Under this third floor of the building was yet another, Floor C.6:51 = C.4:37. This was again a hard-compacted dirt floor with some *huwwar* fragments, ash, charcoal, and considerable bone.¹⁸ In the western sector it touched Walls C.4:9 and 70, but it was heavily trenched and pitted to the east, especially by animal activity. Among the registered objects (all from C.4:37) were nails (422-425), two slingstones (440, 444), and a sickle blade fragment (445). Especially significant was the discovery of a lamp (1008) in a niche against a plastered bench (C.4:38) built along the south wall.¹⁹ The lamp contained a coin hoard of 66 pieces, which

¹⁵ Pit C.6:73 produced the following bones: 7 sheep/goat, 10 large mammal, 10 chicken, 1 fish, 18 undistinguishable, 66 scrap.

¹⁶ Locus C.6:45 produced the following bones: 6 sheep/goat, 3 chicken, 1 turtle, 10 undistinguishable, 8 scrap.

¹⁷ Terian, "Coins 1971," no. 182.

¹⁸ Locus C.6:51 yielded the following bones: 14 sheep/goat, 1 cattle, 4 chicken, 2 fish, 1 undistinguishable, 18 scrap.

¹⁹ See "Heshbon 1971," Pl. VI:A.

were primarily dated A.D. 1260-1277.²⁰ Once again, the latest pottery was Ayyūbid/Mamlūk.

The plastered bench (C.4:38), built up against Walls C.4:9 and 70, was founded on soil Layer C.4:53, to be discussed below. The plaster on top of the bench continued up the sides of both adjacent walls. The bench itself measured 3.20 x 0.65 m. and was 0.60 m. high. It was constructed of worked building stones and incorporated a column drum laid horizontally. Floor Loci C.4:34, 37, 43 ran up against the bench, while Floor C.4:30 covered it completely. The latest pottery from the bench was Ayyūbid/Mamlūk.

Below Floor C.6:51 = C.4:37 was soil Layer C.6:67 = C.4:43, composed of grayish-brown soil, small to medium stones, and ash. This layer also reached Walls C.4:70 and C.4:9 = C.6:2, but was heavily disturbed elsewhere (by Pits C.4:42, C.6:50, 73, and by animal Hole C.6:56). Ayyūbid/Mamlūk was again the latest pottery attested.²¹ Beneath soil Layer C.6:67 in the eastern sector of the building was a remnant of a badly preserved plaster surface (C.6:72), which had been cut by Pit C.6:50 and various animal burrows. It was not clearly associated with any walls of the north building, although its latest pottery was also Ayyūbid/Mamlūk. It produced a bronze coin dated ca. A.D. 400 (2676).

Outside the north building to the south were a number of other architectural features in C.4 and C.6. Partially exposed above the topsoil along the balk between the two Squares was Wall C.4:16 = C.6:6. Composed mostly of worked stones in two rows with a rubble interior, it extended northward from the south balk of C.4 for 5.00 m. and abutted Wall C.6:2 of the north building. In places Wall C.4:16 = C.6:6 survived to a height of six courses and averaged 0.60 m. in width. Only the portion of the wall in C.6 was dismantled and this operation produced Ayyūbid/Mamlūk pottery.

West of this wall and beneath the topsoil (C.4:1) were subsoil Layers C.4:3, 5. The former was gray to yellow in color and averaged 0.10 m. in depth. The latter was dark brown, littered with large stones, and averaging 0.30 m. in depth. Both soil layers covered the entire Square except for the north building and yielded Ayyūbid/Mamlūk pottery.²² Beneath these soil layers in the southern sector of the Square a cistern cut in bedrock (C.4:7) was found. A masonry collar had been constructed around its mouth. Only partially filled by debris, the cistern was bell shaped with a maximum interior diameter of 2.70 m. and a depth of 5.05 m. The collar diameter was 0.85 m., while the diameter of the mouth was 0.38 m. Three courses of masonry were built above the collar stone, forming a kind of lip around the opening of the cistern. Ayyūbid/Mamlūk sherds were found inside, in a silt cone of debris 2.00 m. high (C.4:14). Among the 68 pails of pottery

²⁰ The latest datable Mamlūk coin was A.D. 1268/9; thus Terian suggests that the coin hoard may have been left in the early 1270's ("Coins 1971," published coins 96-161, pp. 41-46).

²¹ Locus C.6:67 produced one registered object, an ivory die (2653).

²² Locus C.4:3 produced an undated bronze coin (251). Locus C.4:5 yielded a basalt basin fragment (271), iron spike (261), and two datable coins: one from the 3d century A.D. and the other from the Mamlūk period ("Coins 1968," nos. 9, 38).

from the cistern were several whole or restorable vessels, as well as a Nabataean coin. The mouth of the cistern was sealed by soil Layer C.4:5.

Beneath C.4:5 elsewhere in this sector (between Walls C.4:2 and 16, and the east and south balks) were soil Layers C.4:6, 17 (= 19), 23, 33. These layers were of mixed colors and hardness, but all contained many large and small stones and fine-grained soil. A number of worked, rectangular building stones were found in these loci, as well as considerable Ayyübid/Mamlük pottery and objects. Under C.4:6 was soil Layer C.4:17 = C.4:19. Within this layer were patches of charcoal and ash, as well as bones—sheep/goat, donkey, pig, chicken, and fish.²³ Soil Layer C.4:19 was rich in objects, yielding an arrowhead (365), clay disc (412, found in a charred condition), slingstone (420), glass tessera (522), and basalt grinder fragment (657). Near the corner of the west and south balks was soil Layer C.4:23, which produced an Umayyad coin (A.D. 661-750)²⁴ and a slingstone (427). This soil layer partially overlay Wall C.4:13, a massive north-south wall which ran from Wall C.4:2 to the south balk. This massive wall is fully discussed elsewhere in this issue, in the context of the defenses of the site.²⁵

Between Walls C.4:2, 13, and 15, and beneath Layer C.4:17 in the center of the Square, *huwwar* Surface C.4:28 was discovered. This surface touched all three walls as well as a *tabun* (C.4:36) located in the angle formed by the juncture of Walls C.4:2 and 13. Surface C.4:28, composed of a thin *huwwar* layer plus a firm gray soil immediately underneath, measured 1.50 x 2.00 m. and averaged 0.20 m. thick. Its latest pottery was Ayyübid/Mamlük. The *tabun* (C.4:36) was ca. 0.90 m. in diameter. Both the *tabun* and the *huwwar* surface were founded on soil Layer C.4:41, which seemingly dated from an earlier period and will be discussed below (under Strata IX-XIV). Under Layer C.4:6, to the east of Wall C.4:15 and west of the east balk, was soil Layer C.4:33, composed of gray, pebbly soil and large scattered rocks strewn in a north-south line 2.20 m. long. It also produced Ayyübid/Mamlük pottery and rested on C.4:41.

West of Walls C.4:8 and 13, beneath Layers C.4:5, 6, were soil Layers C.4:22, 25, 31. Relatively thin (0.09 m.) but heavily rock strewn, C.4:25 ran under Wall C.4:10 (which abutted the north building) and into the north and west balks. All three loci reached the west balk and yielded Ayyübid/Mamlük pottery, although considerable Byzantine pottery was also present. While Layer C.4:31 lay partially under C.4:25, all three loci overlay soil Layer C.4:39 and should probably be considered contiguous.²⁶

The cistern (C.4:7) in the southern sector of the Square has been mentioned above. It was connected to two bedrock-cut water channels (C.4:32, 68), the former of which ran from the cistern to the rock-cut basin (C.4:71). Water Channel C.4:32 extended southeast from the cistern for 3.50 m., with

²³ LaBianca, "The Zooarchaeological Remains from Tell Hesbân," *AUSS* 11 (1973): 135-138.

²⁴ Terian, "Coins 1971," no. 65.

²⁵ Mare, "Area C.1, 2, 3, 5, 7," above.

²⁶ The three loci produced the following registered objects: C.4:22—iron rod (421); C.4:25—carved stone fragment (396), nail (404), ring (403), balance weight (519), slingstone (551), worked quartz (552); C.4:31—iron object (374).

a maximum width of ca. 1.00 m. at its southeast end. Connecting the west side of the cistern with the rock-cut basin, C.4:68 consisted of two channels. The straighter, east-west channel measured 0.88 m. long and averaged 0.08 m. wide, while the curved channel was 1.60 m. long and averaged 0.08 to 0.10 m. in width. The rock-cut basin measured 1.15 x 0.65 m. and was at least 0.35 m. deep, but its bottom was never reached.²⁷ All three loci (C.4:32, 68, 71) produced pottery from several periods, but the latest from each was Ayyübid/Mamlük.

In C.6, besides the eastern end of the north building discussed above, several other major walls appeared immediately below the topsoil. Wall C.6:6 = C.4:16, which abutted Wall C.6:2 to the north, has also been examined previously. In the southwest corner of the Square was Wall C.6:3, a small curving single row of stones surviving to three courses high, which ran from the south balk to the west balk. It abutted Wall C.6:6 in the west balk and measured 2.30 m. long. When dismantled it produced Ayyübid/Mamlük pottery. Just to the east, Wall C.6:4 emerged from the south balk and extended northward for 3.50 m. It was constructed of a double face of both cut and uncut stones with a rubble-and-fill interior. This wall was 0.75 m. wide and was preserved to a height of four courses. Demolition of this wall yielded large amounts of Ayyübid/Mamlük pottery, an Umayyad coin (A.D. 661-750), a *ballista* (2366), and a basalt grinder (2375).²⁸ Abutting this wall on its northeast end was Wall C.6:7, which formed a doorpost adjacent to Threshold C.6:37. This threshold (see Pl. VII:B), flanked on the east by Wall C.6:29, served as a northern entrance into a room (hereafter called the "south room") formed by Walls C.6:4 on the west, C.6:7, 29 on the north, C.6:36 on the east (which could be seen in the east balk but was not excavated), and the south balk. Connecting Wall C.6:4 of the south room with Wall C.6:2 of the north building was Wall C.6:15, a curving north-south wall constructed of two faces of coursed masonry with a rubble interior. This wall abutted both Walls C.6:2, 4 and measured 1.45 m. long and 1.00 m. wide. By connecting the north building to the south room, Wall C.6:15 divided the remainder of C.6 into two distinct courtyards: one in the southwest sector formed by Walls C.6:6, 2, 3, 4, 15 and the other in the northeast bounded by Walls C.6:2, 4, 7, 8 (a wall in the northeast corner but covered by our access stairs), 19, 29 and Thresholds C.6:28, 37. Excavation of Wall C.6:15 produced a Nabataean coin of Aretas IV (9 B.C. - A.D. 40),²⁹ several other objects,³⁰ and Ayyübid/Mamlük pottery. Some bone material was also found within the wall.³¹

²⁷ This locus also produced a possible whetstone (418). Thompson in his 1971 report noted the possible parallel of a rock-cut cistern, water channel, and settling basin found by N. Glueck at Sela in southern Jordan (*The Other Side of the Jordan*, 2d ed.; Cambridge, Mass., 1970, p. 204).

²⁸ This locus produced the following bones: 17 sheep/goat, 6 chicken, 2 large mammal, 21 undistinguishable.

²⁹ Terian, "Coins from the 1973 and 1974 Excavations at Heshbon" (hereafter as "Coins 1973-74"), *AUSS* 14 (1976): 138, published coin 272.

³⁰ Iron disc (1940), iron nail (1941), whetstone (1943).

³¹ Locus C.6:15 contained the following bones: 19 sheep/goat (1 charred), 5 large mammal, 1 fish.

Beneath the topsoil of C.6 was subsoil Layer C.6:5 (already discussed above in connection with the north building), which covered almost the entire Square and varied in depth from 0.25 to 1.00 m. Under this layer, outside the sector covered by the north building, were soil Layers C.6:9, 11, 12 (=16), 13. All these loci were heavily strewn with large stones, were rich in objects and bones, and yielded large amounts of Ayyūbid/Mamlūk pottery. Soil Layer C.6:11, found on both sides of Wall C.6:4, produced an Ayyūbid coin (dated A.D. 1193-1198),³² several bronze objects, and many bones.³³ It touched Walls C.6:2, 3, 4, 6, 15 in the southwest courtyard and extended into the southeast room where it touched Walls C.6:4, 7. Under C.6:11 in this room and extending northward into the northeast courtyard was soil Layer C.6:12 = 16, composed of loose gray soil and large stones, and averaging 0.33 to 0.70 m. in depth. It reached Walls C.6:4, 7, 8, 15, 19, 29 and the north, east, and south balks. This soil layer was also extremely rich in objects and bones.³⁴ Especially noteworthy among the objects was a Mamlūk ostrakon with the fragmentary inscription "and four."³⁵ Within soil Layer C.6:16, against the east face of Wall C.6:15, was Pit C.6:14, filled with loose gray and black soil, *tabun* material, and ash. It produced Ayyūbid/Mamlūk pottery, a few bones, and several metal objects.³⁶ Its dimensions were difficult to ascertain since it blended into C.6:16. Directly under C.6:11 and over the threshold (C.6:37) was soil Layer C.6:13, which was 0.25 m. thick and contained two objects: an iron hook (1820) and iron cleat (1821).

Three of the walls surrounding the southwest courtyard (C.6:2, 4, 6) proved to be rebuilds over earlier-phase walls. Wall C.6:2 of the north building was rebuilt over Wall C.6:57. Wall C.6:4 of the south room was constructed above Wall C.6:62, and Wall C.6:6 was a rebuild of Wall C.6:32 along and partially within the west balk. Two of the walls (C.6:32, 57) were constructed of two faces of masonry with an interior rubble fill. But the third (C.6:62) was built of only a single row of mostly cut stones. Wall C.6:32 abutted C.6:57 on its south face, but there was no direct connection

³² Terian, "Coins 1973-74," published coin 293.

³³ Locus C.6:11 yielded a bronze ring (1771), bronze ring fragment (1819), bronze rod (2003), as well as a lamp handle (1883). It also produced the following bones: 44 sheep/goat, 3 large mammal, 7 cattle, 2 pig, 6 chicken, 1 fish, 6 undistinguishable.

³⁴ Locus C.6:12 included a lamp fragment (2047), as well as the following bones: 14 sheep/goat, 4 undistinguishable. Locus C.6:16 yielded a decorated marble fragment (1803), stone disc (1868), stone fragment (1866), possible slingstone (1881), two iron nails (1800, 1814), iron mirror (1874), iron hook (1867), iron bar (1860), iron rod (1887), toggle pin fragment (1888), jewelry (1863). The same locus produced the following bones: 57 sheep/goat, 7 cattle, 1 chicken, 3 parrot fish, 11 undistinguishable.

³⁵ E. Nitowski, "An Inscribed Mamlūk Sherd," *AUSS* 14 (1976): 163-164. The ostrakon was originally part of a glazed bowl base. Nitowski suggests that the inscription may have been part of a date, commemorative number, or measurement number.

³⁶ Locus C.6:14 contained a bronze wire ring (1720), iron ring (1842), iron tack (1845).

between C.6:57 and C.6:62. None of these walls was excavated, but both C.6:32 and C.6:62 were founded on bedrock.

Beneath C.6:11 in the southwest courtyard were two more soil layers (C.6:20, 22 = 54), which rested on a hard-packed surface composed of gray soil, stones, and *huwwar* (C.6:23 = 55, 58). All these loci were located between Walls C.6:2, 3, 4, 15, and the south and west balks, and all produced Ayyūbid/Mamlūk pottery. Soil Layer C.6:20, immediately under C.6:11, averaged 0.20 to 0.25 m. thick. Many of its stones were worked building stones but were randomly scattered. It was rich in bone remains and also produced several objects.³⁷ Beneath C.6:20 was Layer C.6:22 = 54, composed of multicolored soil, small stones, and some *huwwar* fragments. It averaged 0.20 to 0.35 m. thick and produced a Mamlūk coin dated A.D. 1361-1363.³⁸ It also yielded a bronze rod (1706) and several bones.³⁹ Under this soil layer was a *huwwar* surface (C.6:23 = 55, 58), 0.25 to 0.30 m. thick, which ran up to and touched earlier-phase Walls C.6:32, 57, 62. But Walls C.6:3, 15 were both founded on this surface. It produced several objects and a very large number of bones.⁴⁰

Beneath Surface C.6:23 was soil Layer C.6:25 = 69, which was composed of soft brown soil with some large worked stones. This layer covered the entire southwest courtyard and varied in thickness from 0.25 to 0.70 m. The locus yielded two objects and its latest pottery was Ayyūbid/Mamlūk.⁴¹ Removal of C.6:25 revealed an east-west oriented wall (C.6:31) and two more surfaces, one north (C.6:33 = 71) and another south (C.6:30 = 70) of the wall. This wall ran under both Wall C.6:32 to the west and Wall C.6:62 to the east. Consisting of only one row of mostly cut stones and surviving one course high, it measured 2.22 x 0.26 m. Surface C.6:33 = 71 ran up to and over Wall C.6:31 on the north, while Surface C.6:30 = 70 touched the wall on its south face at a slightly lower level. Thus the wall formed a kind of step between the two surfaces. The more northern of these surfaces (C.6:33 = 71) was composed of hard-compacted *huwwar* layers and soil, and touched Walls C.6:31, 32, 57, 62. Its latest pottery was Ayyūbid/Mamlūk. Intrusive through this surface and reaching bedrock was Pit C.6:75, which was located just north of the intersection of Walls C.6:31 and C.6:62. Measuring 0.84 m. in diameter x 0.57 m. deep, it contained considerable ash, no bone, and a few

³⁷ This locus included the following bones: 28 sheep/goat, 3 large mammal, 1 possible cat, 1 possible camel, 1 pig, 1 chicken. This locus also yielded the following registered objects: bronze sheet (1894), iron nail (1895), blue bead fragment (1898), faience and stone ring (1889).

³⁸ Terian, "Coins 1973-74," published coin 300.

³⁹ Equivalent Locus C.6:54 yielded a stone bead (2517), and the following bones: 17 sheep/goat, 7 horse, 3 large mammal, 16 undistinguishable, 58 scrap.

⁴⁰ Locus C.6:23 yielded an iron ring (1979), bronze wire (2020), faience bead (2024), bead (2025), and the following bones: 76 sheep/goat, 21 large mammal, 8 cattle, 3 camel, 1 horse, 3 fish, 15 undistinguishable. Equivalent Locus C.6:54 contained an iron pipe (2563), glass bead (2556), as well as the following bones: 2 sheep/goat, 2 chicken, 1 fish, 3 scrap. Locus C.6:43 yielded a bronze rod (2655) and the following bones: 3 sheep/goat, 2 undistinguishable, 20 scrap.

⁴¹ Locus C.6:25 contained a bead (2068) and a bracelet (2075).

sherds, the latest of which were Late Roman. Beneath the Surface (C.6:33 = 71) were two additional soil layers (C.6:76, 77). Both touched and were located between Walls C.6:31, 32, 62, while only C.6:77 reached Wall C.6:57 to the north. Layer C.6:76, the upper layer, yielded a glass bead (2687) and a few sherds, the latest being Late Roman. Beneath it was Layer C.6:77, which rested on bedrock. It produced two objects (iron hook 2742; iron ring 2753), several bones, and Ayyūbid/Mamlūk pottery.⁴²

South of Wall C.6:31 and under C.6:25 was *huwwar* surface and sub-floor Layer C.6:30 = 70, which rested on bedrock. Averaging 0.05 to 0.10 m. in thickness, this surface touched Walls C.6:32, 31, 62 and reached the south balk. The latest pottery from the surface was Ayyūbid/Mamlūk.⁴³ Near the intersection of Walls C.6:31 and C.6:62 was a small pit (C.6:88) cut into bedrock and measuring 0.60 m. in diameter. Surface C.6:30 = 70 ran up to the pit, which was encircled by a ring of small stones. It contained loose soil, wood ash, several bones,⁴⁴ a rubbing stone (2859), and Ayyūbid/Mamlūk pottery.

Returning now to the southeast room, beneath soil Layer C.6:12 = 16 was soil Layer C.6:18, a hard-packed light-brown soil with a few rocks and traces of burning. It reached Walls C.6:4, 7, 29, extended over the threshold (C.6:37), and averaged 0.30 to 0.35 m. in depth. This soil layer yielded several iron objects, a few bones, and Ayyūbid/Mamlūk pottery.⁴⁵ Under C.6:18, 13 was the threshold, about 0.81 m. wide and composed of four cut stones of roughly equal size. Cut into one stone was a door socket (see Pl. VII:B). Touching Walls C.6:7, 29, this threshold yielded no pottery or other occupational material. Beneath the threshold and Layer C.6:18, two floors (C.6:24, 35) were encountered. Both of these were composed of hard-compacted soil and patches of *huwwar* plaster. The upper of these floors (C.6:24) touched Walls C.6:4, 7, 29 and the east and south balks. Thus it covered the entire room (1.96 x 2.18 m.) and averaged 0.05 to 0.15 m. thick. This floor was very rich in pottery (Ayyūbid/Mamlūk predominating), bones, and metal objects.⁴⁶ The lower floor (C.6:35), however, was cut by foundation Trench C.6:44 (for Wall C.6:4 along its eastern face) and by soil Layer C.6:60 (a small patch of soil under C.6:7). It did appear to touch Wall C.6:29, as well as the east and south balks. The floor averaged 0.07 m. thick. Its latest pottery was Ayyūbid/Mamlūk but, unlike the floor above, it produced no objects and only a few bones.

Foundation Trench C.6:44, which cut Floor C.6:35, was sealed over by

⁴² Locus C.6:77 produced the following bones: 10 sheep/goat, 1 chicken, 4 undistinguishable, 22 scrap.

⁴³ Locus C.6:30 produced the following bones: 3 sheep/goat, 2 cattle, 1 horse, 1 large mammal, 5 undistinguishable, 15 scrap.

⁴⁴ 10 sheep/goat, 1 large mammal, 14 scrap.

⁴⁵ Locus C.6:18 yielded two iron nails (1921, 1966), iron bracelet fragment (1922). It also produced the following bones: 11 sheep/goat, 2 rat.

⁴⁶ Locus C.6:24 produced a bronze wire (2251), iron knife point (2252), iron buckle (2250), iron nail (2264), worked sandstone fragment (2281); also the following bones: 22 sheep/goat, 2 large mammal, 3 chicken, 3 undistinguishable, 107 scrap.

Floor C.6:24. The trench ran northward along the east face of Wall C.6:4 until it reached Wall C.6:7. It measured 1.81 m. long by 0.11 m. wide with an average depth of 0.10. It produced Ayyūbid/Mamlūk pottery, a bronze ring (2362), and a few bones. Under the foundation trench and the second floor a cobbled floor (C.6:59) was found. This floor did not extend over the entire southeast room but hugged the south and east balks, touching Wall C.6:62 (the earlier-phase wall beneath C.6:4). The cobbles themselves, irregularly shaped but of relatively uniform size, overlay a hard, compact layer (considered part of the same locus). Its latest pottery was Ayyūbid/Mamlūk, although a number of sherds from the Early Byzantine period were also represented.⁴⁷

Just north of the southeast room, below Layer C.6:16 = 12 in the northeast courtyard, was soil Layer C.6:27. Composed of fine granular soil, charcoal flecks, and small stones, it extended westward from the east balk up to Walls C.6:4, 7, 29, and Threshold C.6:37. It thus covered the entire courtyard (2.94 x 2.40 m.) to an average depth of 0.12 m. It produced Ayyūbid/Mamlūk pottery and a few bones. Below C.6:27 was a cobbled surface (C.6:34) that covered the entire courtyard and extended a little beyond its confines. Constructed of mostly uncut but uniform-sized stones and compacted brown soil, the floor extended from the east and south balks and ran under Walls C.6:7, 19, Thresholds C.6:27, 37, and the northern part of Floor C.6:24 in the southeast room. But it ran up to and touched Walls C.6:29, 57 (the earlier phase of C.6:2), and 62 (earlier phase of C.6:4). Averaging 0.20 to 0.30 m. thick, this cobbled surface yielded large amounts of Ayyūbid/Mamlūk pottery, numerous bones,⁴⁸ and a stone weight (2280). Beneath this surface was Layer C.6:46 = 61, which was thickly strewn with stones from pebbles to boulders in size and covered almost all the courtyard to an average depth of 0.20 m., producing a few Ayyūbid/Mamlūk sherds though most of its pottery was Early Byzantine.⁴⁹ What seemed to be a continuation of this layer to the south was C.6:61, located in the southeast room under cobbled Floor C.6:59. Like C.6:46 this layer averaged 0.20 m. in depth and was filled with different-sized stones, loose dark-brown soil, and some charcoal flecks. Its pottery was also similar: a few Ayyūbid/Mamlūk sherds were present but Early Byzantine pottery was predominant.⁵⁰ It touched Wall C.6:62 to the west but ran under Wall C.6:29 along the east balk.

Two entrances into the northeast courtyard have already been discussed above. Threshold C.6:28 provided access from the courtyard into the north building, while Threshold C.6:37 connected the southeast room with the courtyard. A third doorway was found on the east side of the courtyard in the balk between C.6 and C.8. Within this latter Square more evidence was

⁴⁷ Locus C.6:59 yielded the following bones: 2 sheep/goat, 2 cattle, 1 fish, 7 scrap.

⁴⁸ Locus C.6:34 produced the following bones: 24 sheep/goat, 9 large mammal, 1 cattle, 1 rodent, 8 chicken, 56 undistinguishable, 11 scrap.

⁴⁹ Locus C.6:46 yielded the following bones: 10 sheep/goat, 3 large mammal, 4 cattle, 6 chicken, 6 undistinguishable, 68 scrap.

⁵⁰ Locus C.6:61 produced the following bones: 8 sheep/goat, 4 large mammal, 1 donkey, 2 undistinguishable, 24 scrap.

discovered which indicated an extension of the Ayyūbid/Mamlūk building complex eastward, further up the slope of the tell.

Beneath the topsoil (C.8:1) of C.8 a subsoil layer (C.8:2) was encountered, which covered the entire Square (8.00 x 6.00 m.). It was light brown in color, heavily strewn with large stones, and produced Ayyūbid/Mamlūk pottery. Layer C.8:2 averaged 0.10 m. in depth and yielded a bead (2044) and a ceramic disc (2045).⁵¹

Removal of the topsoil and subsoil layers revealed a number of well defined walls. Extending northward from the doorway mentioned above, in the common balk between C.6 and C.8, was Wall C.8:14. Constructed mainly of undressed limestone and surviving to a height of five courses, this wall measured 1.80 x 0.90 m. Only its eastern face was exposed, however, since the western face was obscured by the balk. This wall formed part of the eastern side of the northeast courtyard in C.6. Abutting this wall on its northern end was east-west Wall C.8:6 = 10, which was composed of two rows of coursed stones with a rubble interior. It extended into the west balk, and is possibly equivalent to Wall C.6:8. Thus, this wall formed the northern boundary of the northeast courtyard of C.6 as well as the western room of C.8. In this latter Square the wall survived in places up to four courses high of both cut and uncut stones, with an average width of 0.60 m. and measuring 2.95 m. in length. Bonded into the eastern end of C.8:6 was Wall C.8:5 = 7, which extended southward almost the full length of the Square and disappeared into the south balk. The northern half of this wall was a skin wall attached to the west face of Wall C.8:4, while the southern half was free standing. The total length of this wall was 5.35 m., while the width varied from 0.50 m. (for the skin wall) to 1.00 m. (for the free standing portion). It was preserved in places up to seven courses high. Bonded into this wall near its juncture with the south balk was Wall C.8:8, which served as the south wall of this room. It ran westward from Wall C.8:5 = 7 for 1.80 m. before disappearing into the west balk, where it may have connected with Wall C.6:36 of the southeast room. Only the northern face of Wall C.8:8 was situated outside the balk. Upon excavation this wall produced Ayyūbid/Mamlūk pottery, a pestle (2947), and several bones.

In the center of the Square was Wall C.8:4, already referred to in the preceding paragraph. Composed of two rows of coursed stones with a rubble interior, this wall measured 3.50 x 1.20 m. and survived to a height of seven courses on its eastern (exposed) face. Abutting this wall on its southeast end was Wall C.8:9, which extended eastward into the east balk. Following the typical pattern of wall construction in the entire complex, it consisted of two rows with an interior rubble fill. Four of its courses were preserved on the north face, but only 2½ on the south. Its maximum length (south face) was 3.40 m., while it averaged 0.90 m. wide. Removal of this wall revealed an earlier-phase wall beneath, to be discussed below. This operation also produced Ayyūbid/Mamlūk pottery, two objects, and a large number of bones.⁵² Abutting Wall C.8:4 to the northeast was Wall C.8:15, consisting

⁵¹ Locus C.8:2 contained the following bones: 7 sheep/goat, 2 rat, 2 undistinguishable.

⁵² Locus C.8:9 yielded an iron disc (2622) and a glass bead (2603). It also

of a single row of stones (1.10 x 0.45 m.) one course high, which reached the east balk. This wall also produced Ayyübid/Mamlük pottery and was built upon an earlier-phase wall (C.8:20).

Thus, these walls of C.8 bounded part of three distinct rooms of the complex. The western room of C.8 was surrounded by Walls C.8:5 (= 7), 6, 8, 10, and the west balk, which also contained the doorway leading to the northeast courtyard of C.6. Walls C.8:4, 9, 15 and the east balk enclosed the eastern room. A distinct north-south wall protruded through the ground surface just beyond the east balk, and thus probably formed the east wall of this room. The juncture of Walls C.8:5 = 7 and C.8:9 in the southeast sector formed an L-shaped corner of a possible third room. No entrances were apparent in either of these latter two rooms, but doorways could have been located beyond the balks.

Beneath the topsoil and subsoil loci (C.8:1,2) in the western room was soil Layer C.8:11 = 26, composed of loose brown soil filled with numerous large stones and averaging 1.22 m. thick. This layer covered the entire room (5.80 x 2.00 m.) and touched Walls C.8:5 (= 7), 6, 8, 14, and the west balk. This layer was rich in Ayyübid/Mamlük pottery, bones, and objects, including a 3d century A.D. coin of Neapolis.⁵³ Beneath this thick soil layer several superimposed floors and occupational layers were encountered (C.8:28, 35, 39, 42, 44), all of which produced Ayyübid/Mamlük pottery and were located in the northern half of the room. Floor C.8:28, the uppermost of these, was a badly damaged *huwwar* floor with large pockets of ash. Covering space 1.72 x 1.65 m. and averaging 0.10 m. thick, this floor touched Walls C.8:5, 14, and Installation C.8:29 (a semi-circular ring of stones containing some ash, probably a hearth). Floor C.8:28 also ran up to the doorway in the west balk and ran under C.8:27, a secondary blockage of the doorway.⁵⁴ The hearth (C.8:29) was 0.64 m. in diameter but produced no bones nor objects.

Beneath Floor C.8:28 was soil Layer C.8:35, very thin (0.03 m.), which touched Walls C.8:5, 6, 14, and Hearth C.8:29. It produced only a few sherds, bones, and *ṭabun* fragments. This layer sealed a second floor (C.8:39), as well as a partly preserved *ṭabun* (C.8:38). This second floor was similar to C.8:28. It was composed of *huwwar* but was somewhat thicker, averaging 0.20 m. Relatively sterile in content, the floor touched Walls C.8:5, 6, 14, and Hearth(?) C.8:29. This floor was founded on a third floor (C.8:42) of beaten earth approximately 0.15 m. thick. It reached Walls C.8:5, 6, 14, Hearth C.8:29, and *Ṭabun* C.8:38. The last of these loci from the northern sector

produced the following bones: 23 sheep/goat, 4 large mammal, 1 donkey, 1 fish, 10 undistinguishable, 53 scrap.

⁵³ The coin was object 2476. Locus C.8:11 yielded the following registered objects: iron ring (2286), iron arrowhead (2274), iron spatula fragment (2464), iron slag fragment (2532), two iron nails (2463, 2518), stone strainer (2407), ceramic disc (2572), mortar fragment (2571). The locus also produced the following bones: 79 sheep/goat, 18 large mammal, 2 cattle, 1 dog, 1 rodent, 12 chicken, 2 fish, 50 undistinguishable, 282 scrap.

⁵⁴ Locus C.8:28 produced an iron nail (2682) and the following bones: 1 sheep/goat, 1 chicken, 1 fish, 2 undistinguishable, 38 scrap.

of the room was soil Layer C.8:44, found immediately below Floor C.8:42. Measuring 2.30 x 1.45 m. and 0.35 m. in depth, this layer was composed of loose soil, stones, and chips of *nari* limestone. Containing a bronze bar (2816) and some bones,⁵⁵ this layer ran under Walls C.8:5, 6, 14. Hearth(?) C.8:29 and *Ṭabun* C.8:38 were both founded on this layer, which extended southward to Wall C.8:30 = C.6:84, an earlier-phase wall discussed below.

In the eastern room of C.8, removal of the topsoil and subsoil loci revealed a thick soil layer (C.8:3) packed with large stones, similar to C.8:11 = 26 in the west room. Averaging 0.25 m. in depth, Layer C.8:3 touched Walls C.8:4, 9, and the east balk, and covered Wall C.8:15 to the north. This layer produced an Arabic lamp (2094), Ayyūbid/Mamlūk pottery, and a few bones. Two coins were also associated with this locus. Although identification of the coins was hampered by their poor state of preservation, one was possibly Umayyad (A.D. 661-750) while the other was possibly Ayyūbid (A.D. 1171-1342).⁵⁶ Under C.8:3 in this room was soil Layer C.8:17, composed of loose brown soil with a few small stones. Extending over the entire room (3.26 x 2.33 m.) to an average depth of 0.40 m., this locus touched Walls C.8:4, 9, 15, and the east balk. It contained Ayyūbid/Mamlūk pottery, considerable bone, and one interesting but unidentified object.⁵⁷ Beneath this layer was a badly pitted *huwwar* floor (C.8:18) with charcoal pockets. It was heavily damaged by animal holes and rock fall, and was completely lost in places. The floor was trenched by Wall C.8:15 to the north, but touched Walls C.8:4, 9. Averaging 0.10 m. thick, the floor contained large amounts of Ayyūbid/Mamlūk pottery, bone, and objects, among which was a Mamlūk coin of Az-Zahir (2471, dated A.D. 1382-1399) and a whole lamp (2379).⁵⁸ Also beneath C.8:17 and founded on Floor C.8:18 was Installation C.8:21, an enclosed corner near the juncture of Walls C.8:4, 9. The space was marked off by a single row of five stones, enclosing a sector 0.60 x 1.00 m.

Floor C.8:18 sealed two other installations: a *ṭabun* (C.8:23), located near the north face of Wall C.8:9, and a storage installation (C.8:24) which extended into the east balk. The *ṭabun* was in a fragmentary state of preservation, with only the bottom and side walls left *in situ*. It was covered by two distinct layers of stones and was filled with ash and charcoal. It contained very little pottery (Ayyūbid/Mamlūk), bone (one charred), and a ceramic loom weight fragment.⁵⁹ The *ṭabun* measured 0.80 m. in diameter. In the northeast corner was Installation C.8:24, a rectangular storage area (1.45 x

⁵⁵ Locus C.8:44 contained the following bones: 12 sheep/goat, 6 large mammal, 2 chicken, 1 undistinguishable, 32 scrap.

⁵⁶ Terian, "Coins 1973-74," pp. 140-141, published coins 293, 294.

⁵⁷ Locus C.8:17 produced an undefined perforated stone and iron fragment (2247); also the following bones: 6 sheep/goat, 1 fish, 12 undistinguishable, 63 scrap.

⁵⁸ Locus C.8:18 produced also an iron hook (2290), two iron nails (2307), iron hinge fragment (2356), slingstone (2300); also the following bones: 34 sheep/goat, 5 large mammal, 1 cattle, 6 chicken, 3 fish, 24 undistinguishable, 5 scrap.

⁵⁹ Locus C.8:23 produced the following bones: 1 sheep/goat, 1 large mammal, 1 rodent (charred), 1 undistinguishable, 6 scrap.

0.48 m.) bounded by a single row of uncut stones standing up to four courses. Inside the installation was soil and ash, beneath which was an interior *huwwar* surface (C.8:33). Excavation of the installation produced Ayyūbid/Mamlūk pottery and a few bones, but no other evidence to suggest function.

Beneath Floor C.8:18 was soil Layer C.8:22, a thick (0.45 m.) subfloor layer rich in remains which covered the entire room. It was composed of fairly compact soil with small rocks and chunks of ash. It touched Walls C.8:4, 9, and 20, the last an earlier-phase wall under C.8:15. The layer contained large amounts of Ayyūbid/Mamlūk pottery, much bone, and several objects.⁶⁰ The *ṭabun* (C.8:23) was founded on this soil layer, which was cut by Installation C.8:24. Below C.8:22 was soil Layer C.8:25 = 40, the bottom Mamlūk layer within the eastern room. Installation C.8:24 was founded on this layer, which touched Walls C.8:4, 9, 20, and the east balk. Composed of firm soil with chunks of limestone and clay, this layer averaged 0.30 m. in depth and covered the entire room. It contained some Ayyūbid/Mamlūk pottery, but earlier ceramic forms, especially Late Roman, tended to predominate. Soil Layer C.8:25 also produced a whole Mamlūk juglet (2419), glass bead (2677), bronze rod (2648), and a Nabataean coin (2873, no precise date, but certainly pre-A.D. 106). The locus was also exceptionally rich in bone remains.⁶¹

In the northern sector of the Square, between Walls C.8:6, 10, 15, and the north and east balks, removal of the topsoil and subsoil layers revealed a thick rock-filled soil layer (C.8:13) over 1.00 m. deep. For lack of time the bottom of this layer was not reached, and no surfaces associated with this end of the building complex were found. The latest pottery from this locus was uniformly Ayyūbid/Mamlūk, and it also produced a coin of Constantine, A.D. 306-337 (2667).⁶²

In the southeast portion of C.8, between Walls C.8:7, 9, and the south and east balks, four similar rock-strewn layers were encountered (C.8:12, 19, 31, 43). All contained loose soil and Ayyūbid/Mamlūk pottery. Soil Layer C.8:12 measured 3.74 x 1.80 m. and averaged 0.52 m. in depth. It contained a whetstone (2090), plus a few bones. Beneath C.8:12 was Layer C.8:19. It was strewn with different-sized stones, ash pockets, and chunks of *huwwar*. It averaged 0.70 m. deep. Among the objects from this locus was a coin (2318), perhaps late Ptolemaic in date (pre-30 B.C.). Animal bones were found in abundance.⁶³ Below C.8:19 was a much thinner (0.13 m.) soil layer (C.8:31), which covered only a portion of this sector (3.21 x 1.62 m.). It was also com-

⁶⁰ Locus C.8:22 yielded the following registered objects: iron tag (2305), iron hook (2365), iron nail fragment (2364), glass bead (2363), ceramic pendant (2506). It also produced the following bones: 69 sheep/goat, 8 large mammal, 9 cattle, 5 dog, 13 chicken, 1 fish, 109 undistinguishable, 37 scrap.

⁶¹ Locus C.8:25 produced the following bones: 47 sheep/goat, 7 large mammal, 1 cattle, 8 pig, 2 camel, 5 chicken, 17 undistinguishable, 121 scrap.

⁶² Locus C.8:13 also yielded an iron nail (2681) and produced the following bones: 39 sheep/goat, 3 large mammal, 3 cattle, 5 dog, 3 rodent, 8 chicken, 15 undistinguishable, 54 scrap.

⁶³ Locus C.8:19 contained a sea shell fragment (2283) and the following bones: 28 sheep/goat, 7 large mammal, 1 cattle, 3 chicken, 1 fish, 17 undistinguishable, 122 scrap.

posed of large stones, fine loose soil, and pockets of ash. It contained a silver ring (2609) and several bones. Immediately beneath C.8:31 was soil Layer C.8:43. By this time removal of Wall C.8:9 to the north and excavation of the upper soil layers in this sector had revealed several earlier-phase walls (C.8:48, 50, 53) which seemed to have supported a vaulted roof (C.8:32), now mostly collapsed. Soil Layer C.8:43, which partially covered the remnants of this vault, was filled with many large and obviously worked building stones and measured 3.21 x 1.62 m. with an average thickness of 1.04 m. Although its latest associated pottery was Ayyübid/Mamlük, many Umayyad sherds were also present. This locus touched earlier-phase Walls C.8:48, 50, 53.

The fifth and last of these heavily rock-strewn layers from this sector was C.8:46, found beneath C.8:43. For lack of time only a limited part of this locus (2.25 x 1.70 m.) was excavated. This lay between earlier-phase Walls C.8:48, 50, 53, and the south balk. Its average depth was 1.16 m., and it produced Ayyübid/Mamlük pottery.⁶⁴ Bedrock was reached beneath this layer. Cut into the bedrock was a circular hole (C.8:56) measuring 0.70 m. in diameter and filled with loose soil. The close of the 1976 season unfortunately prevented the clearing of this installation, which perhaps served as a cistern or grain silo. The earlier-phase walls located around this installation will be discussed below.

In C.9 and C.10, the two new Squares opened during the 1976 season, further evidence of the Mamlük building came to light. Beneath the topsoil (C.9:1, 10; C.10:1) a fairly thick subsoil layer was encountered (C.9:2, 3, 5, 14; C.10:2, 3, 4, 13). This brown layer covered virtually all of both Squares. It was heavily strewn with stones ranging in size from pebbles to boulders, and some of these were obviously worked building stones. The pottery from this subsoil layer was quite mixed, but the latest datable sherds were uniformly Ayyübid/Mamlük. Of particular interest was the numismatic evidence. Locus C.9:3 contained a Nabataean coin (2474), while Locus C.9:14 included two Mamlük coins (2664, 2673, not precisely dated but which must fall between A.D. 1250-1517), and a Roman coin of Antoninus Pius (2668, A.D. 138-161). Locus C.10:4 yielded a coin of Justin II (2478, A.D. 565-578). This soil layer was also rich in bone material and produced a number of objects.⁶⁵

By the time removal of these loci was completed, the outlines of a rather substantial building had appeared (see Fig. 7, over). Only a portion of this

⁶⁴ Locus C.8:46 produced the following registered objects: steatite bead (2804), agate fragment (2913).

⁶⁵ Locus C.9:3 produced an Ayyübid/Mamlük pilgrim's flask (2475). Locus C.9:5 yielded a bullet (2302), bronze pin fragment (2303). Locus C.9:14 produced a possible stone weight (2586), iron ring (2647), glass bead (2629). All these loci (plus C.9:2) produced the following bones: 59 sheep/goat, 9 large mammal, 1 cattle, 4 chicken, 3 turtle, 63 undistinguishable, 633 scrap (the large amount of scrap bone is at least partly caused by the sifting process used in the "Test Square," which facilitated the recovery of small bone fragments ordinarily missed during normal excavation). Locus C.10:4 produced an incense-altar fragment of limestone (2446). Loci C.10:2, 3, 4, 13, produced the following bones: 77 sheep/goat, 7 large mammal, 2 cattle, 1 donkey, 2 camel, 2 possible gazelle, 7 chicken, 13 undistinguishable, 734 scrap.

building could be exposed, but even the exposed part measured 8.50 x 7.00 m. and included at least three rooms. The northern largest room was only partially exposed. It was delineated by Walls C.9:4, 8 (= C.10:27), C.10:5, and the north balk of both Squares. Wall C.9:4, the south wall of this room, survived in four courses of mostly worked stones extending southward 2.63 m. from the north balk and founded on bedrock. Running eastward from this wall was Wall C.9:8 = C.10:27, a well constructed wall of limestone blocks surviving up to eight courses. It formed the south wall of the room. The pronounced lean of its upper courses to the north suggested that it formed part of a vault (see Pl. VIII:A). This wall formed part of an exterior northern face of a triple wall some 2.50 m. thick. It consisted of an inner middle wall (C.9:21), two outer walls (C.9:8, 25, 35), and a rubble fill in between. The southern face of this massive wall served as the northern limit of the two smaller rooms to be discussed below. The eastern limit of the northern room was formed by Wall C.10:5, a single row of stones preserved to a height of at least six courses, although its bottom was not reached. It abutted Wall C.9:8 = C.10:27 to the south and reached the north balk. It was constructed of both worked and unworked stones, and measured 2.00 x 0.25 m. Behind this end wall of the building to the east, a foundation trench had been cut into the earlier soil layers. This trench had then been filled with soil, large and small stones, and other debris (C.10:17, 23, 24, 29, 30, 31). The fill was composed of loose gray soil with a few chunks of cement. It contained Ayyübid/Mamlük pottery, some bone, but almost no objects.⁶⁶

Inside this northern room, immediately below the subsoil loci, were several thick soil layers chocked with large cut building stones (C.9:7 = C.10:15; C.9:9, 11, 13). Some of these stones (especially in C.9:9) were found in clearly discernible rows or lines, suggesting wall or ceiling collapse. These soil layers were composed of compacted, clay-like soil with some ash flecks. They contained considerable pottery (the latest being Ayyübid/Mamlük) and bone remains, but almost no objects.⁶⁷ The combined maximum depth of these layers in C.9 was 1.47 m. Its bottom was not reached in C.10.

Beneath these loci the large cut building stones gave out, as soil Layer C.9:20 was encountered. It was composed of brown clay-like soil with some charcoal flecks, limestone pebbles, and chunks of reddish fired mud brick. It touched Walls C.9:4, 8 and the east and north balks. It measured 2.25 x 4.20 m. and its average depth was 0.25 m. Despite the fact that this locus lay directly on the uppermost floor of the room, the layer contained only very few sherds (Ayyübid/Mamlük), no objects, and only a few small bones.

Floor C.9:18, immediately below C.9:20, was composed of multiple thin earth layers closely packed together with *huwwar* pockets and bits of charcoal. It ran up to and touched Walls C.9:4, 8, and the north and east balks. Averaging 0.15 to 0.20 m. thick, it contained Ayyübid/Mamlük pottery, two

⁶⁶ Locus C.10:29 produced a glass bead (2678). Loci C.10:17, 23, 29 yielded the following bones: 10 sheep/goat, 2 large mammal, 1 cattle, 1 chicken, 7 undistinguishable, 44 scrap.

⁶⁷ Locus C.9:11 yielded an iron sheet (2640). Loci C.9:7, 11, C.10:15 produced the following bones: 50 sheep/goat, 21 large mammal, 3 cattle, 8 chicken, 38 undistinguishable, 282 scrap.

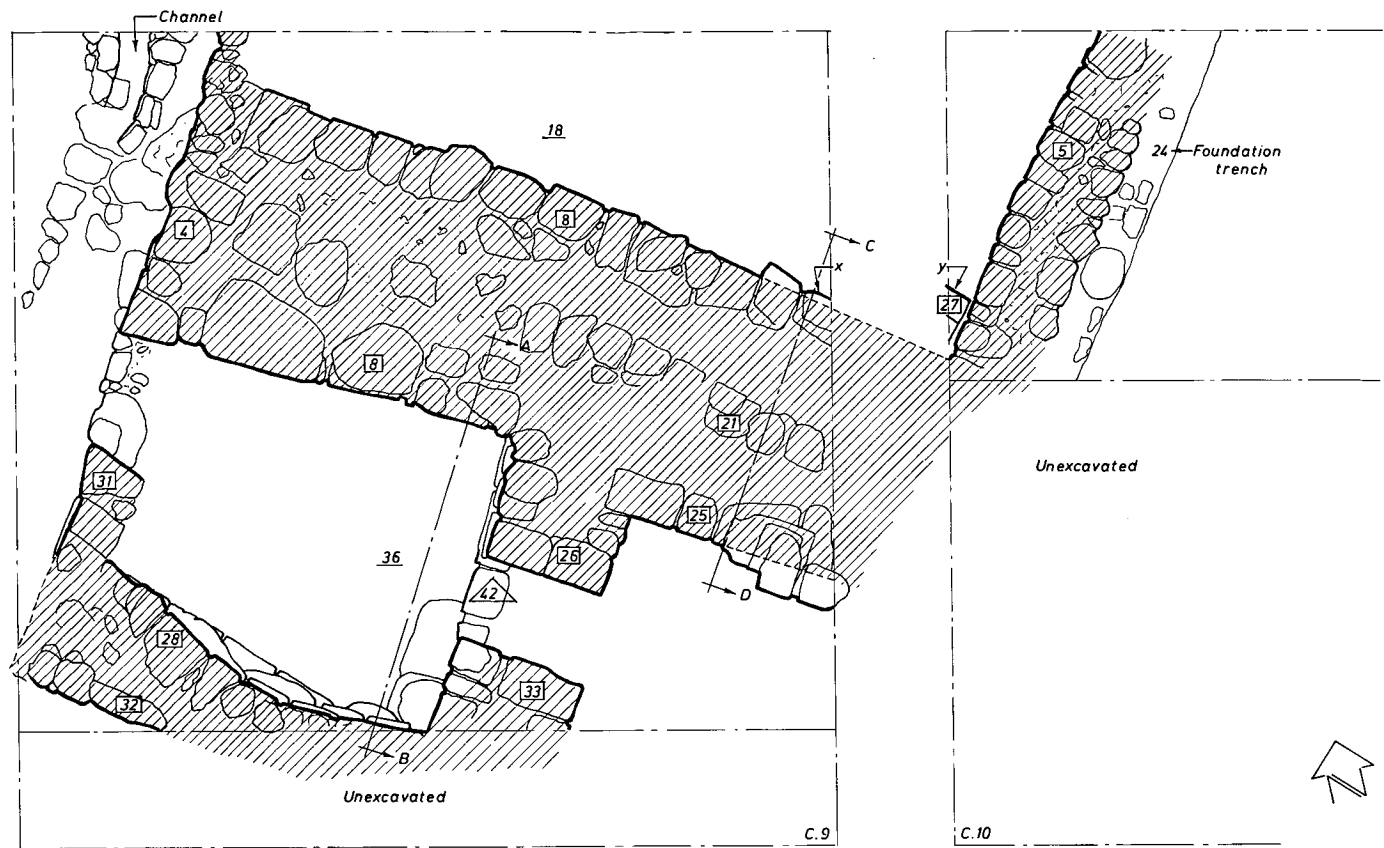

PLAN

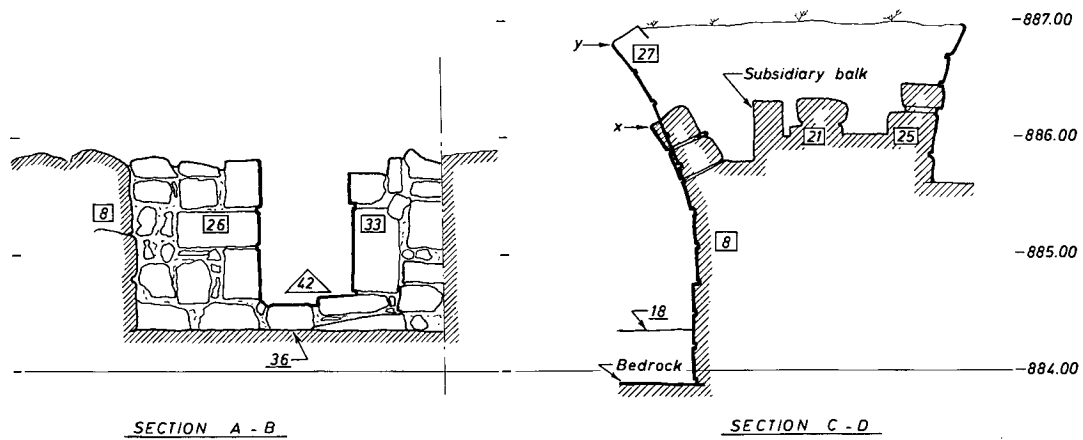

SECTION A - B

SECTION C - D

HESHBON 1976
 AYYUBID - MAMLUK HOUSE
 DRAWN JULY 1976 BY:
 BERT DEVRIES
 DAVID PIPER
 ANITA VAN ELDEREN
 DANIEL SALZMANN

0 .40 .80 1.20 1.60 2.00M.

Fig. 7. Partial plan and sections of Mamlük domestic complex in Squares C.9, 10 (cf. Fig. 13 in 1974 report).

slingstones (2789, 2820), and a few bones. A curious feature of this floor was four pairs of circular cup-like depressions, filled with reddish earth and nothing else (see Pl. VIII:B). Each depression measured ca. 0.09 m. in diameter, with an average depth of 0.05 m.

Under this floor of the northern room were two soil layers (C.9:45, 46), which in turn rested on a second floor (C.9:48). Both of these soil layers were composed of brown soil, *huwwar* chunks, and small stones. Both also produced Ayyūbid/Mamlūk pottery and extended from Walls C.9:4, 8 to the north and east balks. Soil Layer C.9:45 averaged 0.10 m. in depth and contained a slingstone (2894) and several bones. Layer C.9:46 averaged 0.15 m. deep and produced an iron sickle fragment (2882), bronze pin (2884), iron ring (2899), slingstone (2911), and some bones.⁶⁸

Beneath soil Layer C.9:46 were *huwwar* Floor C.9:48, soil Layer C.9:49, and Pits C.9:47, 58, 61. Floor C.9:48, in the western end of the room, touched Walls C.9:4, 8, and the north balk. Measuring 2.90 x 0.70 m. and averaging 0.08 m. thick, it suddenly broke off to the east. It contained no pottery or other artifactual remains. Partially beneath it but extending almost the entire length of the room was soil Layer C.9:49, a very thin (0.05 m.) locus similar in color and composition to C.9:46. It contained Ayyūbid/Mamlūk pottery but no bones or objects. Below this layer in places was bedrock, while above it and against the east balk was Pit C.9:47, filled with black earth, ash, and charcoal. It measured 0.50 x 0.12 m. with an average thickness of 0.03 m. Its latest pottery was Umayyad, though it contained only a few sherds. Under C.9:49 along the east face of Wall C.9:4 was fill Layer C.9:63, which was laid into a cut in bedrock. It was excavated to a depth of 0.35 m. but its bottom was not reached. Composed of loose dirt and small rocks, it also produced Ayyūbid/Mamlūk pottery.

No entrance was found into the northern room of the building, though one certainly could have existed to the north beyond the balk. Entrances for the other two rooms, however, were located to the south. Exterior access to the southwestern room was located to the west between Walls C.9:4 and C.9:31. The former of these walls extended southwestward from the north balk for 2.63 m. and survived up to four courses. It averaged 1.20 m. wide and was constructed of both dressed and undressed limestone blocks. Wall C.9:31 extended northeastward from the west balk. It was built of dressed limestone blocks with smaller, irregular stones on top. These two walls flanked a threshold (C.9:62) which provided access into the building from the west. Elsewhere the room was bounded by Walls C.9:35 to the north, C.9:26, 33 to the east, and C.9:28 (a slightly curving wall) to the south. Between Walls C.9:26 and C.9:33 was Threshold C.9:42, which provided access into the third, or southeastern room of the building. This room was thus bounded by Walls C.9:26, 33 to the west, C.9:25 to the north, and the east and south balks. None of these walls was excavated, but all were constructed of both worked and unworked stones and small chink stones. Walls C.9:26, 33, 28(=32), 25 were all composed of two facings of coursed masonry with a rubble interior.

⁶⁸ Loci C.9:45, 46 produced the following bones: 9 sheep/goat, 3 chicken, 11 undistinguishable, 46 scrap.

Turning first to the southwestern room (3.00 x 3.25 m.), beneath the top-soil and subsoil layers three additional layers were encountered: C.9:29 (= 30), 36, 38. All three were composed of loose soil and filled with stones of all sizes, particularly large building stones. These layers extended over the entire room to a depth of ca. 1.00 m. and all produced Ayyūbid/Mamlūk pottery.⁶⁹ Beneath these soil layers was Floor C.9:51, composed of patchy *huwwar* and dark-brown hard-packed earth with traces of burning. For lack of time this floor was exposed in only a 1.00 x 2.00 m. probe trench against the face of Wall C.9:35 in the northern sector of the room, as were all lower loci in this room. Under this floor was a thin (0.03 m.) soil layer (C.9:52), which in turn rested upon a second *huwwar* floor (C.9:53). This lower floor also showed traces of burning in small patches and averaged 0.09 m. thick. Finally, under Floor C.9:53 was soil Layer C.9:56, the lowest level reached in the probe before the close of excavation. All these loci uniformly contained Ayyūbid/Mamlūk pottery and all touched Wall C.9:35. None produced any registered objects, however, and almost no bone.

Beneath soil Layer C.9:38, in the corner of the southwestern room formed by Walls C.9:28, 33, was Pit C.9:40, filled with brownish-red soil, chunks of charcoal, and some pieces of burned Ayyūbid/Mamlūk cooking pots. The depth of the pit was 0.15 m., and its maximum depth was ca. 1.00 m.

The southeastern room of the building (2.25 x 2.00 m.) presented similar stratigraphy. Beneath the subsoil were two soil layers (C.9:22, 37) heavily strewn with large cut and uncut stones. Layer C.9:22 averaged 0.42 m. in depth and contained an iron nail (2720) and many small bones.⁷⁰ Layer C.9:37, somewhat lighter in color and about the same thickness (0.41 m.), contained an iron ring fragment (2792) and two coins. The earlier of these (2876), dated to the reign of the Roman Emperor Arcadius (A.D. 395-408), while the other (2880) was Mamlūk (A.D. 1250-1517). This locus was also rich in bone remains.⁷¹ Under these two layers the absence of large cut building stones was noticed in the next soil layer (C.9:39). It was composed of clay-like, hard-packed soil with streaks of disintegrated limestone and ash. This layer was thinner (0.20 m.) and contained a few bones. All three loci touched Walls C.9:25, 33 and the east and south balks, and all produced Ayyūbid/Mamlūk pottery.

Beneath these soil layers was a series of three superimposed floors (C.9:41, 43, 44). All were composed partly of *huwwar* chips and partly of hard-packed earth and small stones. Floor C.9:41, the uppermost, covered the entire room, averaged 0.20 m. thick, and extended over Threshold C.9:42. This threshold

⁶⁹ Locus C.9:29 = 30 yielded an iron horseshoe (2696) and two possible stone weights (2699, 2700). Locus C.9:36 produced an iron nail (2867), while Locus C.9:38 yielded another iron nail (2791), loom weight (2829), and a bronze Nabataean coin (2871). These loci also produced the following bones: 69 sheep/goat, 23 large mammal, 3 cattle, 1 dog, 1 donkey, 10 chicken, 1 fish, 63 undistinguishable, 1156 scrap.

⁷⁰ Locus C.9:22 contained the following bones: 12 sheep/goat, 1 chicken, 9 undistinguishable, 188 scrap.

⁷¹ Locus C.9:37 produced the following bones: 31 sheep/goat, 2 cattle, 2 chicken, 14 undistinguishable, 409 scrap.

was constructed of two large, flat, dressed limestone blocks forming an opening 0.82 m. wide. Floor C.9:43 was much thinner (0.05 m.) but yielded a few bones. The bottom floor (C.9:44) was similar to Floor C.9:43 in composition.⁷² All three floors produced Ayyūbid/Mamlūk pottery but no registered objects. All three also touched Walls C.9:25, 26, 33, and the east and south balks. Under Floors C.9:43, 44 two pits (C.9:50, 54) were discovered, as well as soil Layer C.9:60, which was not excavated for lack of time. Pit C.9:50 (0.30 x 0.67 m.) was located in the northwest corner, formed by Walls C.9:25, 26, bounded on the east and south by four large stones in a semi-circular arrangement. It contained dark reddish-brown soil, black charcoal, gray ash, and small pebbles. The pit was intrusive through Floor C.9:44, while Floor C.9:43 touched it. The pit was not excavated. Pit C.9:54 (0.64 x 0.58 m.) was encountered sealed beneath Floor C.9:44. It also contained dark reddish soil, some ash, and small pebbles. Excavated to a depth of 0.25 m., its bottom was not reached before the close of excavation. It produced Ayyūbid/Mamlūk pottery, but no objects.

The western sector of C.9, lying outside the building, was also investigated. Beneath the topsoil (C.9:1 = 10) subsoil Layers C.9:5, 17 (= 15), 19 were encountered. These loci also produced Ayyūbid/Mamlūk pottery, a few bones, and together averaged 0.80 m. in depth. Under Layer C.9:19, the lowest of these loci, bedrock was reached. A deep cut running north to south and parallel to Wall C.9:4 had been made in the bedrock. Into this cut a large number of regular-sized stones (ca. 0.10 x 0.10 m.) had been tightly packed, forming a sump (C.9:34 = 54). Above the sump was a water channel (C.9:24) built of two parallel curving rows of unworked stones (ca. 0.20 m. apart) which extended 1.07 m. from the north balk to the west balk. Within the water channel was a Roman coin (2937) of Pontius Pilate (A.D. 31/32). Both the water channel and the sump produced Ayyūbid/Mamlūk pottery, but no other artifactual remains. The depth of the sump was at least 0.50 m., but its bottom was not reached before the end of excavations.

Interpretation: It seemed clear from the evidence cited above that there was a substantial occupation in this sector of Tell Ḥesbân during the Mamlūk period. Virtually all other sectors of the site have also produced considerable material from this period. Within the eastern Squares of Area C the large number of *ṭabuns*, fire pits, small storage installations, numerous domestic artifacts, and thousands of animal bones all suggest a domestic function for the building complex. This is further suggested by the relatively modest size of the rooms, the entrances (with the exception of the double-socket Threshold C.6:28 in the north building), and the absence of any architectural or artifactual evidence

⁷² Loci C.9:39, 43, 44 produced the following bones: 5 sheep/goat, 1 large mammal, 1 horse, 1 chicken, 4 undistinguishable, 47 scrap.

which would suggest public structures. Because all the buildings have been only partially exposed, the actual number of individual buildings cannot be determined. But certainly the north building of C.4, C.6, the structure within C.8, and the east building of C.9, C.10 represent independent structures. Part of a possible fourth building may be represented by the southeast room of C.6, but this is uncertain.

The Mamlūk period occupation in C.4, C.6, and C.8 seems to fall into three phases: 1) the initial resettlement of this sector (beginning ca. A.D. 1260) involving the leveling of the ground surface, demolition or rebuilding of earlier walls, and construction of the major buildings and installations of the Area, 2) a period of rebuilding and modification of the phase-one structures, 3) a time of abandonment and disuse (beginning ca. A.D. 1400) leading to the collapse and filling in of these structures.

During the resettlement of phase one, the Mamlūk period inhabitants employed no uniform or consistent method of preparing this sector of the site for their structures. In some places, such as the north building, they merely rebuilt existing walls left from the Byzantine period. They leveled parts of this sector with a rubble fill (C.6:46=61) and cleaned out the C.4 water channels (C.4:32, 68, 71) and cistern (C.4:7) for reuse. A similar pattern appears in C.8, where previously existing Roman walls were utilized as foundations for the Mamlūk structures. But in C.9 this sector was leveled down to bedrock before the erection of the east building. This can also be observed in the southwestern courtyard of C.6, where Ayyūbid/Mamlūk soil layers were found directly over bedrock. Apparently, much of this cleared material and debris was pushed down the slope to the west, where thick layers of deep fill were found.⁷³

The best evidence for dating this initial occupation phase is the coin hoard found in Floor C.4:37 (the lowest of a series of superimposed floor levels) against the bench (C.4:38) from with-

⁷³ Thompson, "Heshbon 1971: Area C," pp. 72-73.

in the north building. The hoard contained coins dated A.D. 1260-1277 and thus was probably deposited in the 1270's. This would support the suggestion of J. A. Sauer that "a major occupation commenced at Ḥesbân in ca. 1260."⁷⁴ This first phase witnessed the construction of the north building and perhaps the other major structures of the Area as well, with the possible exception of the east building in C.9 and C.10.

The date of the start of the second phase cannot be precisely determined, but it almost certainly falls in the 14th century. Again, the numismatic evidence should be considered. A coin dated A.D. 1363-1377 came from C.4:24, an occupation layer immediately above the uppermost floor (C.4:26) of the north building. By this time the bench (C.4:38) had been completely covered over and the arched doorway in the south wall had been blocked (C.4:60, 61). Another coin dated A.D. 1382-1399 was imbedded in the uppermost floor (C.8:18) of the C.8 building to the east. From C.6:22, an occupation layer immediately above the uppermost *huwwar* surface (C.6:23) of the southwestern courtyard, came another coin dated A.D. 1361-1363. Thus, these coins provide a *terminus post quem* of ca. A.D. 1380-1400 for the end of the second phase. The evidence again supports Sauer's suggestion that "the Mongol invasion under Tamerlane would probably have caused the essential abandonment of the site in ca. 1400/1401."⁷⁵

Several architectural modifications were carried out within the building complex during the second phase of occupation. In C.4 Wall C.4:10 was attached to the west end of the north building⁷⁶ possibly indicating an extension or enlargement of the structure. The arched doorway in the south wall was blocked in

⁷⁴ Sauer, "Heshbon 1971: Area B," p. 38. (Sauer's suggestion that this re-occupation occurred after the defeat of the Mongol forces ca. A.D. 1260 by the Mamlûks under Baybars I [A.D. 1260-1277] seems to fit the evidence best.)

⁷⁵ Ibid.

⁷⁶ Wall C.4:10, which abutted Wall C.4:8, was founded on soil Layer C.4:25, which ran up to and touched Wall C.4:8. Thus Wall C.4:10 represents a later addition to the building.

two stages (C.4:60, 61), as has been mentioned above. Since the north end of Wall C.4:15 rested against the blockage of the doorway, it must be even later in date. On the east end the elaborate sunken stone-paved threshold (C.6:28), with its double door sockets, was also a later modification of the north building. This is illustrated by the foundation trench (C.6:40) of the threshold, which cut through all the floor layers of the building. Also probably belonging to this later phase are Walls C.6:3, 15, both of which were founded on Surface C.6:23, the uppermost surface of the southwestern courtyard. The construction of Wall C.6:15, which abutted Walls C.6:2, 4, then divided the northeast and southwest sectors into two separate courtyards. The function of the northeast courtyard would primarily have been to serve as an access route connecting the east threshold of the north building (C.6:28), the north doorway (C.6:37) of the southeast room, and the doorway in the balk between C.6 and C.8 — although this doorway was also later blocked (C.8:27). Secondary functions could have included domestic cooking, as suggested by the fire pit (C.6:14) built against Wall C.6:15 and thus also belonging to this phase.

The southwestern courtyard, on the other hand, may have served as an animal enclosure. This is suggested by the architectural nature of Walls C.6:3, 15, which seem too insubstantial and poorly constructed for house walls. Wall C.6:3 in particular seems suitable as a kind of trough for feeding animals. Further, Surface C.6:23, upon which both walls were built and thus initially used, produced very large numbers of domestic animal bones, including sheep/goat, cattle, chicken, camel, and large mammal. The occupation layers above this surface also contained similar faunal remains.⁷⁷ Threshold C.6:37 of the southeast room may also be placed in this later phase; it touched and was

⁷⁷ Loci C.6:11, 20, 22, 23 together produced the following bones: 164 sheep/goat, 27 large mammal, 21 cattle, 4 camel, 1 horse, 1 cat, 3 pig, 7 chicken, 4 fish, 22 undistinguishable.

in primary association with Floor C.6:24, the uppermost floor of the room.

The development of the structures in C.8 as well as the east building of C.9 and C.10 was much less clear. This was primarily due to the relative lack of associated contemporary numismatic evidence,⁷⁸ and the inability to excavate more fully several of the rooms in both of these buildings. This was particularly felt in the two southern rooms of the east building, where most of the occupation layers and floors were reached only by small probes. In the vaulted north room of the east building, however, where bedrock was reached, the presence of only two *huwwar* floors (C.9:18, 48) and a total occupation depth of only ca. 0.50 m. suggest a fairly brief period of use. Perhaps this building was constructed somewhat later than the other Mamlūk structures (possibly in the 14th century?), but this is simply conjecture.

The third and final phase of the Mamlūk period was characterized by the disuse of at least this sector of Area C. The coin dated A.D. 1382-1399 from the uppermost floor (C.8:18) of the C.8 building, another dated A.D. 1363-1377 from the occupation layer (C.4:24) above the uppermost floor of the north building, and a third dated A.D. 1361-1363 from the occupation layer (C.6:22) above the uppermost surface of the southwest courtyard of C.6 all suggested that this disuse phase began ca. A.D. 1400. This was further supported by the lack of any precisely datable coins after A.D. 1400 and the complete absence of any Ottoman period pottery. This phase was characterized by the collapse of ceilings and walls and the gradual filling in of the rooms and courtyards by the thick subsoil layers strewn with tumbled building stones. The earthquake of A.D. 1456 probably hastened this process, although the buildings were never completely covered. There was no evidence of a widespread conflagration or a systematic destruction of the complex. This evi-

⁷⁸ Several coins of Nabataean or Roman date appeared in sealed loci in C.8 and C.9, but the presence of considerable Ayyūbid/Mamlūk pottery suggested that these coins were found outside their primary stratigraphic context.

dence rather suggested an abandonment, quite possibly caused, as Sauer suggests, by the advance of the Mongol forces in A.D. 1400.

Without much doubt the Mamlūk period inhabitants relied on domestic animals for a major part of their economic subsistence. The faunal remains from this period suggested the particular importance of sheep, goat, cattle, and chicken as food sources. The much rarer appearance of camel, donkey, horse, dog, and cat bones suggested their use as work animals. The occasional finds of gazelle, turtle, and fish bones may indicate that hunting and fishing made a minor contribution to the food supply in this period. Although ancient botanical remains were quite rare, the presence of such artifacts as sickle blades, mortars, and a basalt grinding mill suggested that agriculture was also practiced. Site-wide flotation samples have produced considerable evidence of barley, wheat, pulses (such as lentil, broad bean, bitter vetch), and olives.⁷⁹ Much of the economic prosperity enjoyed by the inhabitants of this period can possibly be attributed to the site's role as a postal station along the Damascus-Cairo route and possibly as a Ḥāj station along the pilgrimage route to Mecca.⁸⁰

Post-Stratum VI Gap (ca. A.D. 750-1260)

Description: There was no stratigraphic evidence in the eastern sector of Area C between the Mamlūk domestic complex of Strata II-III and the Umayyad remains of Stratum VI. Although the lower levels of the domestic complex were carefully examined for evidence of an earlier Ayyūbid phase, none was found (only several Ayyūbid coins in Mamlūk loci). There was a complete absence of any numismatic evidence from the 'Abbāsīd period (A.D. 750-969), although 'Abbāsīd pottery occasionally appeared.

Interpretation: This negative evidence implied an occupational gap during ca. A.D. 750-1260 in Area C. This corresponded to a

⁷⁹ P. Crawford, Ø. LaBianca, and R. Stewart, "Heshbon 1974: The Flotation Remains," *AUSS* 14 (1976): 185-187; although these results were published without their exact stratigraphic context.

⁸⁰ Sauer, "Heshbon 1971: Area B," p. 38, n. 21 (with full references). The pilgrimage route was reopened by Baybars I after his victory over the Mon-

site-wide abandonment or extremely sparse occupation in the 'Ab-bāsid period, though there was evidence of Ayyūbid occupation elsewhere.⁸¹ The massive leveling, filling, and construction operation of the Mamlūk period might have eradicated all stratified evidence of this period.

Stratum VI: Umayyad (ca. A.D. 661-750)

Description: Stratified evidence of occupation in these Area C Squares came only from C.4. Beneath Wall C.4:8 of the north building, Wall C.4:12 was encountered. Measuring 1.15 m. long and surviving to a height of two courses, this wall consisted of a single row of stones. When dismantled it produced two Ayyūbid/Mamlūk sherds, as well as Umayyad and earlier pottery. Under Layer C.4:19 in the southern half of the Square, near the cistern (C.4:7), soil Layers C.4:35 = 27, 44 were found. Measuring 3.50 x 2.00 m., they touched the cistern and lay over bedrock. With the exception of two Ayyūbid/Mamlūk sherds, the latest pottery was Umayyad. These layers also produced several objects.⁸²

Interpretation: The evidence suggested a relatively minor use of a limited portion of the Area during the Umayyad period, primarily associated with a reuse of the cistern of C.4 (the few Ayyūbid/Mamlūk sherds being probably intrusive). Wall C.4:12 and the large amount of Umayyad pottery found in the later Ayyūbid/Mamlūk strata suggested a substantial Umayyad occupation, though most stratified Umayyad evidence might have been eradicated by the later Mamlūk leveling and construction operations. The original excavator of C.4 considered Wall C.4:50 and soil Layer C.4:51 to be Umayyad.⁸³ But neither produced any Umayyad pottery, and Byzantine pottery clearly predominated; so it seemed preferable to consider these loci as Early Byzantine.

gols ca. 1260. See Philip Hitti, *History of the Arabs*, 5th ed. (London, 1953), pp. 674-676.

⁸¹ Vyhmeister, "History of Heshbon," p. 171. Sauer, "Heshbon 1971: Area B," pp. 42-43.

⁸² Locus C.4:35 produced a stone stopper (538), lamp fragment (571), stone vessel fragment (572). Locus C.4:27 also produced several objects: nail (380), slingstone fragment (402), possible ceramic weight (396). Locus C.4:44 yielded an ivory needle fragment (553), sculptured stone fragment (554), lamp fragment (571).

⁸³ Thompson, "Heshbon 1971: Area C," p. 78.

Post-Stratum IX Gap (ca. A.D. 450-661)

Description: There was no stratigraphic evidence in this sector of Area C between the Umayyad loci of Stratum VI and the Early Byzantine loci of Stratum IX. There were scattered finds of Late Byzantine pottery in several of the Squares, however, and two 6th-century coins.⁸⁴

Interpretation: This evidence suggested a gap in occupation here ca. A.D. 450-661. While some ceramic and numismatic evidence might suggest a slight Late Byzantine occupation that was later eradicated by the Stratum III occupation, the complete absence of any Late Byzantine stratification seemed rather to indicate that this sector was unoccupied in this period.

Strata IX-XIV: Early Byzantine (ca. A.D. 324-450)

Description: Considerable evidence from this period was found, primarily within C.4, C.6, and C.10.

Beneath the north building in C.4 was soil Layer C.4:41 = 53 = 54, a reddish, compact layer flecked with *huwwar*. Averaging 0.25 m. thick, this layer extended southward from the north balk and touched Wall C.4:45. This wall, founded on bedrock, bisected the Square, running northeastward from under Wall C.4:13 for ca. 3.00 m. Walls C.4:2, 9, 70 (all of the north building) were founded on Layer C.4:41 = 53 = 54. This layer contained Early Byzantine pottery, a coin dated to the 4th or 5th century A.D.,⁸⁵ many objects,⁸⁶ and an articulated skeleton of an infant burial, found under a large storage-jar sherd.⁸⁷ Associated with the infant was a bronze buckle (832) and 53 small beads (860).⁸⁸ Within this layer was the foundation trench (C.4:48) for Wall C.4:2 along its south face. It extended eastward from Wall C.4:13 for 2.47 m. and also yielded Early Byzantine pottery. Just to the west was the foundation trench (C.4:76) for Wall C.4:70. It also produced Early Byzantine pottery.

Just to the west and emerging from the north balk was Wall C.4:50, of one row of uncut stones, 1.90 m. long and in three courses, built on and par-

⁸⁴ Wall C.4:2 produced a coin of Justinian dated A.D. 527-565 ("Coins 1971," published coin 64). Soil Layer C.10:4 yielded a coin (2474) of Justin II (A.D. 565-578).

⁸⁵ Terian, "Coins 1971," published coin 178. The coin is a Roman *aes* IV type and its date can be only approximated.

⁸⁶ C.4:41 = 53 = 54 produced the following registered objects: glass bead (576), ivory button fragment (783), black bead (784), stone spindle whorl (861), bronze needle (826), lamp fragment (827).

⁸⁷ See "Heshbon 1971," Pl. VI: B.

⁸⁸ The original excavator of the burial made two very plausible suggestions: that the buckle served as a clasp for the infant's clothes, since the imprint of the clothing fibers could still be recognized on the buckle; and that the small beads (found along the waist) may have served as decoration on the cloth ("Heshbon 1971: Area C," p. 80).

tially covered by several Early Byzantine soil layers (C.4:51, 58, 66, and 55).⁸⁹ Excavation stopped at this point in this sector of the Square.

Beneath soil Layer C.4:41 = 53 = 54 was *huwwar* Surface C.4:52, which ran up to and touched Walls C.4:13, 45. Averaging 0.20 m. thick, this surface produced Early Byzantine pottery and marked the lowest level reached in this sector of the Square.

South of Wall C.4:45, beneath Umayyad soil Layers C.4:27 (= 35), 44 were several Early Byzantine soil layers (C.4:57, 67, 72) around the cistern.

In C.6, as has already been noted, several walls of the Mamlūk domestic complex were founded on three earlier-phase walls (C.6:32, 57, 62). In addition to these was Wall C.6:53 (unexcavated) of two rows of roughly dressed stones extending 1.57 m. from the north balk and exposed to only one course. This wall was touched on the east by Fill C.6:46 (Mamlūk), on the west by soil Layer C.6:74, and was cut on its south end by Wall C.6:57. Soil Layer C.6:74 to the west was composed of clay-like reddish-brown soil and contained Early Byzantine pottery, a few bones, and a worked flint (2755). It was found under Floor C.6:72 (the bottom floor of the Mamlūk north building), and was cut by Wall C.6:57 to the south.

The remaining Early Byzantine loci of C.6 were found in the sector east of Walls C.6:53, 57, 62. Under Fill C.6:46 were soil Layers C.6:66, 78, varying in color from reddish brown to yellow brown and strewn with large stones. Many of these were obviously worked building stones. These layers extended from the north balk to the south balk and touched Walls C.6:53, 57, 62. They contained considerable Early Byzantine pottery (though with a few Ayyūbid/Mamlūk sherds, probably intrusive), many bones,⁹⁰ and a bronze coin (2672) of the Roman Emperor Maximian (A.D. 296-305). Just east of Wall C.6:57 was Surface C.6:65, a badly damaged patch of *huwwar* found under C.6:46 and above C.6:66, averaging 0.04 m. thick. It touched Wall C.6:62 to the south but was cut by Wall C.6:57 to the west. It also contained Early Byzantine pottery. Beneath Layers C.6:66, 78 were soil Layers C.6:79, 83, 85, composed of compact multi-colored soil and many rocks. These layers covered the entire eastern sector along the east balk and touched Wall C.6:62. C.6:83 averaged 0.15 m. in depth, while the bottom of C.6:79, 85 was not reached. These layers contained a few bones, several objects,⁹¹ and Early Byzantine pottery.

Similar remains were found in the southwest corner of C.8. Beneath the thick tumble/collapse (C.8:26) was soil Layer C.8:47, also strewn with large stones (some worked) and composed of fine brown silty soil. Located between Wall C.8:30 and the west and south balks, it averaged 0.65 m. in depth. Wall C.8:7 of the Mamlūk domestic complex was founded on this layer. It included Early Byzantine pottery, an iron implement fragment (2883), plus a few bones. Under C.8:47 were soil Layers C.8:54, 57, both of which overlay bed-

⁸⁹ Locus C.4:55 yielded the following registered objects: marble fragment (824), sherd with a snake design (823).

⁹⁰ Loci C.6:66, 78 produced the following bones: 22 sheep/goat, 5 large mammal, 2 dog, 3 chicken, 5 undistinguishable, 55 scrap.

⁹¹ Locus C.6:79 yielded a ceramic disc (2778). Locus C.6:83 produced a slingstone (2821), while C.6:85 contained an iron nail (2814).

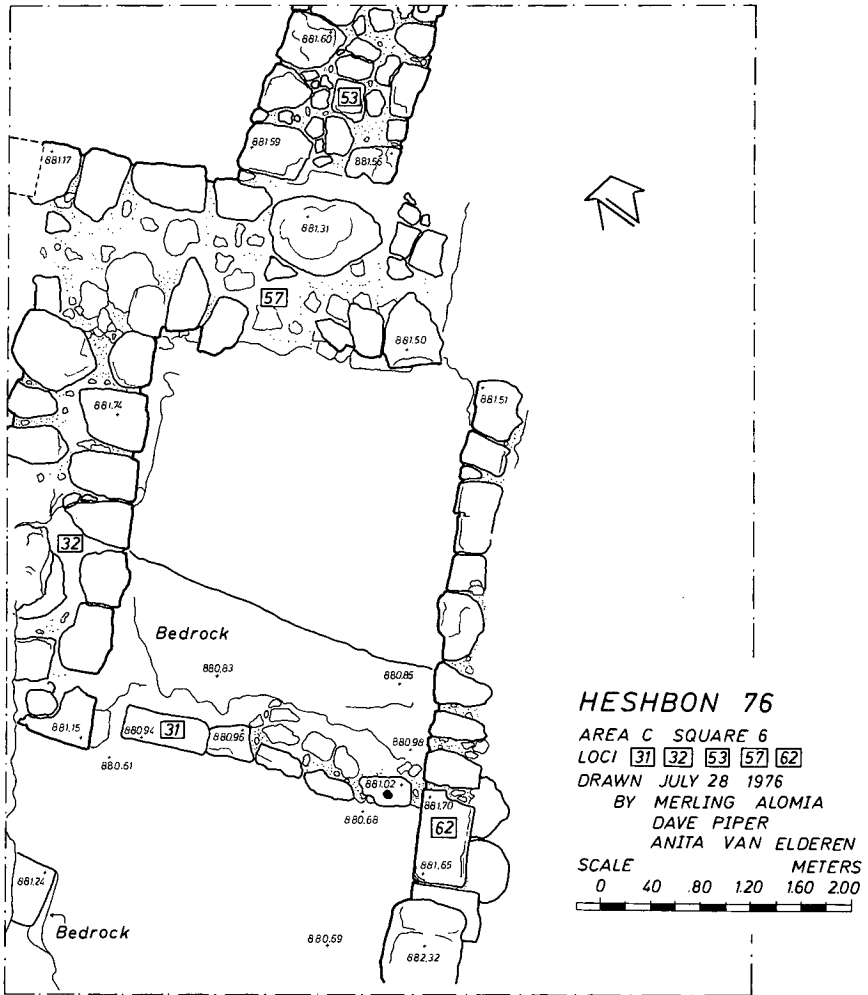

Fig. 8. Plan of Early Byzantine walls exposed in Square C.6.

rock. C.8:54 was composed of fine brown soil with a few stones and *nari* chips. It averaged 0.33 m. in depth, containing a bronze coin of Antoninus Pius (A.D. 138-61),⁹² an iron hinge fragment (2885), and Early Byzantine pottery. Partially under C.8:54 and also against bedrock was soil Layer C.8:57, which contained much ash and *huwwar* and touched Wall C.8:30 on its south face. Averaging 0.15 m. thick, this locus also produced Early Byzantine pottery.

The only evidence from this period in C.9 came from a possible trench (C.9:61) along the north face of Wall C.9:8 inside the northern room of the east building. Measuring 1.21 x 0.21 m. (and thus extending along only a portion of the wall) and averaging 0.22 m. in depth, this trench contained loose brown soil and only a few sherds, the latest being Early Byzantine.

The evidence from C.10 was considerably more complex. Beneath the topsoil and subsoil loci were a number of sloping soil layers, which extended westward until cut off by the foundation trench and back fill (C.10:23 = 24 = 30) of Wall C.10:5, the end wall of the Mamlūk building of C.9 and C.10. The upper of these sloping layers (C.10:7 = 21, 16, 22 = 26) were filled with loose soft soil and strewn with many large rocks. Some also contained chunks of white plaster or loose gravel and all produced Early Byzantine pottery and a few bones. Under Layer C.10:22 = 26 was Wall C.10:20, which extended from the north balk to the south balk and measured 3.00 x 1.20 m. The wall presented a well dressed western face of at least six courses with chink stones throughout and traces of plaster on the lower courses. The stones of the upper courses were smaller and less well dressed. The eastern face was of much poorer construction, however, with no evidence of plaster. The bottom of this wall was not reached before the close of excavation.

Extending from the western face of Wall C.10:20 (and beneath C.10:22 = 26) were additional sloping soil layers (C.10:25, 28, 41, 42). Similar in composition and content to the upper layers, they were also cut by the trench and back-fill of the Mamlūk building to the west. These layers also produced a few bones and Early Byzantine pottery. Beneath these loci were two layers of massive rock tumble (C.10:34, 47), composed of mostly cut building stones (several over 1.00 m. long) and loose orange soil, and containing many air spaces. Averaging 0.75 m. in thickness, these loci also yielded Early Byzantine pottery plus a few bones. Both were also cut by the Mamlūk trench to the west (C.10:24). Under C.10:47 near the north balk was soil Layer C.10:57, composed of loose soil and small rocks, and measuring 1.50 x 1.35 m. It also contained Early Byzantine pottery and was cut by Trench C.10:24.⁹³

Interpretation: In C.4 and C.6 it seemed apparent that a number of walls (C.4:2, 70; C.6:32, 57, 62) which were reused for the Mamlūk domestic complex date to the Early Byzantine

⁹² This was a coin (object 2938) of *Colonia Aelia Capitolina* (Jerusalem).

⁹³ The Early Byzantine loci of Strata IX to XIV produced the following bones (not including bones from C.4, for which data were not available): 82 sheep/goat, 14 large mammal, 3 cattle, 1 donkey, 2 dog, 1 cat, 1 rodent, 10 chicken, 41 undistinguishable, 296 scrap.

period. The foundation trenches (C.4:48 and 76) of Walls C.4:2 and 70, both of which produced Early Byzantine pottery, supported this suggestion. These loci, as well as Wall C.4:50, Surface C.4:52, and Layer C.4:41=53=54 also contained similar pottery, as well as a coin dated to ca. A.D. 400. Thus it appeared that these walls formed one or more buildings (perhaps domestic?) in this eastern sector of Area C. To the south, Early Byzantine Soil Layers C.4:57, 67, 72 around the cistern (C.4:7) suggested a reuse of the cistern in this period. More substantial evidence of occupation may possibly have been destroyed by the massive subsequent Mamlūk occupation.

This was also the problem in interpreting the evidence from C.6, where only one patch of *huwwar* surface (C.6:65) survived to suggest an occupation from the Early Byzantine period. Since this surface touched Wall C.6:62 but was cut by Wall C.6:57 (the earlier phase wall of C.6:2), Wall C.6:62 seemed to be relatively earlier in date. Further, since Wall C.6:57 also cut Wall C.6:53, this latter wall must also be earlier; and earliest of all Wall C.6:31 of the southwestern courtyard, since it ran under both Walls C.6:62 and C.6:32. The Early Byzantine soil layers (C.6:66, 78, 79, 83, 85; C.8:47, 54, 57) to the east of Wall C.6:62 might be interpreted as a massive fill placed to block a huge subterranean chamber (cistern?) found cut into bedrock in the balk between C.6 and C.8. Although this chamber could not be closely investigated, a steel line dropped through an opening indicated that it was at least 13.50 m. deep. An alternate theory was that these loci blocking the chamber were the result of the A.D. 365 earthquake. Either suggestion seemed plausible.

The Early Byzantine trench (C.9:61) of Wall C.9:8 also suggested that the Mamlūk inhabitants might have reused an earlier wall from this period when constructing the vaulted building of C.9. However, since the "trench" — possibly only a soft portion caused by root disturbance or animal activity — had a limited length and yielded few sherds, it seemed best to reserve judgment.

In C.10 the sloping soil layers of this period appeared probably best interpreted as wash and tumble, some perhaps from Wall C.10:20, but since many of the stones were worked building stones, some may have tumbled down from the acropolis enclosure wall or perhaps from acropolis buildings. The construction features of Wall C.10:20, which was well dressed and plastered on its western (down-slope) face but was poorly constructed and unplastered on its eastern face, suggested that it was a retaining wall (see the next section).

Strata XV-XVI: Late Roman (ca. A.D. 135-324)

Description: Evidence of Late Roman occupation in this part of Area C was limited for the most part to C.4 and C.10.

In C.4, under Wall C.4:2 of the north building, single-row Wall C.4:73 was found extending southwestward for 4.00 m. to Wall C.4:45, covered for part of its length by Early Byzantine soil Layers C.4:52, 64; it produced no pottery. South of Wall C.4:45 (the retaining wall for the cistern), and under Early Byzantine Layers C.4:69, 72, were soil Layers C.4:74, 75. Layer C.4:74, which averaged 0.10 m. thick, extended along the south face of Wall C.4:45 and reached the west balk. Beneath it was C.4:75, which averaged 0.50 m. in depth, reached the cistern (C.4:7), and was founded on bedrock. Though C.4:74 produced mostly Early Roman pottery, Layer C.4:75 beneath it yielded some Late Roman pottery.

In C.10, behind plastered retaining Wall C.10:20 already described, up the slope to the east, were a number of fill layers (C.10:12, 14, 19, 33, 35, 36, 39) composed of rock rubble and soil (C.10:33, 35), almost pure, sterile gravel (C.10:36), decayed mud brick (C.10:12), broken roof tiles (C.10:19), and mixed soils (C.10:14, 19, 39). All these loci extended from Wall C.10:20 to the east balk and averaged 0.15 to 0.60 m. in depth. Intrusive through these layers were three small pits (C.10:18, 32, 40). Most of these loci produced a few bones, while the latest pottery from them was Late Roman.⁹⁴

Above these layers were several very thin surfaces (C.10:6, 8, 10, 11), all of which touched Wall C.10:20 and reached the east balk. These surfaces sloped gradually upwards towards the south, and measured 2.25 x 0.80 m. The uppermost of these, Surface C.10:6, was hard-compacted soil and chunks of plaster, containing a few Early Byzantine sherds but mostly Late Roman pottery. Directly under C.10:6, was hard plaster Surface C.10:8, averaging 0.03 m. thick, badly pitted by animal holes. Beneath this plaster surface was soil Layer C.10:9, composed of loose soil, gravel, small rocks, and chunks of plaster, then two beaten earth surfaces (C.10:10, 11), which in turn rested

⁹⁴ Locus C.10:32 produced a seal ring with a crystal inset in the shape of a crescent moon (2712).

on the fills described above. All these surfaces produced a few bones,⁹⁵ no objects of any kind, and Late Roman pottery.

West of retaining Wall C.10:20, under the Early Byzantine rock tumble loci (C.10:34, 37), was a Late Roman wall (C.10:50), of uncut stones in a single row, extending southward 1.50 m. from the north balk and preserved three courses high; and west of this wall under Layer C.10:57 (Early Byzantine), was Late Roman soil Layer C.10:61, the lowest layer reached in this sector of C.10.

Interpretation: In C.4 the evidence from soil Layers C.4:74, 75 around the cistern and pottery under one of the slabs covering the related water channels (C.4:68) had suggested a Late Roman use. From this the original excavator of C.4 suggested that the entire system (Cistern C.4:7, Water Channels and Basin C.4:32, 68, 71) may have been constructed in that period.⁹⁶ This remained a strong possibility, though it could not be demonstrated from the existing evidence.

Up the slope to the east, Wall C.10:20 apparently served as a retaining wall for the various layers. The sloping surfaces constructed on top probably functioned as a ramp providing access between the western slope of the tell and the acropolis. Since the sloping surfaces did not continue through the east balk into Square A.11, they cannot have exceeded 1.80 m. in width. It thus appeared unlikely that the ramp was designed for vehicle traffic but was probably suitable for pedestrians, donkeys, and horses. On the basis of the ceramic evidence it appeared to have been constructed in the Late Roman period and to have continued in use into the Early Byzantine period, since pottery from this latter period was found in the uppermost Surface (C.10:6). Above this were wash and tumble soil layers from the Mamlūk period, so it is possible that higher Mamlūk surfaces were destroyed by erosion. Although the main entrance to the acropolis in the Late Roman period was obviously the monumental stairway on the south slope in Areas B and D, this much

⁹⁵ These Late Roman loci of Strata XV-XVI produced the following bones: 13 sheep/goat, 2 large mammal, 2 cattle, 1 chicken, 12 undistinguishable, 174 scrap.

⁹⁶ Thompson, "Heshbon 1971: Area C," pp. 81-82.

smaller ramp of Area C probably served as a subsidiary access route similar to one found in D.4 (probably Early Roman in date but repaired and reused in the Late Roman period).

Strata XVII-XVIII: Early Roman (ca. 31 B.C.-A.D. 135)

Description: Evidence of occupation from this period in the eastern sector of Area C was mostly confined to C.8 and C.10, though minor evidence came from C.6.

In the eastern half of C.6, beneath the Early Byzantine layers (C.6:66, 78, 79, 83, 85), two walls were found: Wall C.6:86 was located in the southwest corner of the Square, extending 1.64 m. from the south balk before entering the east balk. Constructed of dressed stones one row wide and surviving to two courses, it bordered the deep subterranean installation in the east balk. The wall itself was not dismantled, but was covered by Early Byzantine layers (C.6:78, 83). Wall C.6:84 (probably an eastward extension of Wall C.6:31) was also constructed of dressed stones one row wide. It ran eastward from under Wall C.6:62 into the east balk and apparently continued as Wall C.8:30, (which ran under Mamlūk Wall C.8:7), founded on bedrock. The total length of Wall C.6:31(?), 84 = C.8:30 was 5.65 m., and it appeared to border the subterranean installation to the south. This wall was also unexcavated.

Considerably more remains survived in C.8. Bonded into the northern end of Wall C.8:30 was Wall C.8:45, which extended northward 1.70 m. before running under Mamlūk Wall C.8:6. Unexcavated, it was constructed of roughly dressed stones. Mamlūk Wall C.8:7 was built upon its eastern face. At its northern end Wall C.8:45 abutted Wall C.8:20, a massive east-west wall running from Wall C.8:10 in the northwest corner of the Square to the east balk. Measuring 4.50 x 1.34 m., this wall was built of large (0.60 x 0.40 m.), well dressed limestone blocks and survived to at least six courses. Several later Mamlūk walls (C.8:4, 5, 6, 15) were partially or entirely constructed upon it.

South of Wall C.8:20 was a room, bounded on the west by Wall C.8:4, on the south by Walls C.8:48, 49, 53, and to the east by Walls C.8:37, 41. Thus, the room was situated almost exactly beneath the eastern room of C.8 in the Mamlūk domestic complex, though somewhat smaller in size. The lowest Mamlūk occupation layer (C.8:25) in this room yielded large amounts of Late and Early Roman pottery as its lower levels were reached. Finally the Ayyūbid/Mamlūk pottery gave out altogether. Beneath it was soil Layer C.8:34 = 40, which measured 2.33 x 2.72 m. and averaged at least 0.50 m. in depth, though its bottom was not reached. This soil layer touched Walls C.8:20, 49, 53, overlay Walls C.8:37, 41, and ran under Wall C.8:4. It was composed of loose coarse soil with many small rocks. Except for a few later sherds (probably intrusive), it contained huge amounts of Early Roman III-IV pottery.⁹⁷ The layer was also extremely rich in bone remains, yielding nearly 600 bones.⁹⁸

⁹⁷ The locus yielded 349 registered sherds; many more were discarded. Locus C.8:34 also produced an iron nail (2698) and grinder fragment (2946).

⁹⁸ Locus C.8:34 produced the following bones: 26 sheep/goat, 47 large mam-

In the south wall of this room, formed by Walls C.8:48, 49, 53, there had been an entrance into a room in the southeast corner of the Square. This entrance (0.62 m. wide), flanked by Walls C.8:48, 53, was secondarily blocked by Installation C.8:51. Walls C.8:48, 53 were both constructed of well dressed, rectangular limestone blocks and rested on bedrock. Attached to the north face of C.8:48 was a skin wall (C.8:49) built of uncut stones. The doorway blockage (C.8:51) was composed of small uncut stones and earth and also rested on bedrock.

Bounding this southeastern room on the west was Wall C.8:50, similar in construction to Walls C.8:48, 53, also built on bedrock, and surviving in three courses. It extended 1.22 m. north from the south balk. Mamlük Wall C.8:7 rested partly upon it. The northern end of Wall C.8:50 and the western end of Wall C.8:48 flanked a second, western entrance into the room. This entrance (0.56 m. wide) had also been blocked secondarily by Installation C.8:52, similar in composition to C.8:51. Cut into bedrock within the room was Installation C.8:56, an earth-filled circular hole 0.70 m. in diameter (discussed above with the Mamlük material). The top stones of Wall C.8:53 appeared to serve as the springers of a vault, and further evidence of a partly collapsed vault could be seen in the south balk (C.8:32). Unfortunately, no surfaces were associated with any of these loci, and lack of time prevented any excavation of the walls or blockage loci.

The Early Roman material from C.10 was confined to a limited sector east of the retaining wall (C.10:20). Beneath the Late Roman layers which supported the ramp surfaces a number of soil layers were encountered in a probe intended (though unsuccessfully) to reach bedrock. These soil layers (C.10:45, 48, 51, 52, 55, 58, 60, 62, 63, 64) averaged 0.03 to 0.25 m. in thickness, differed widely in color, hardness, and composition, but all produced Early Roman pottery (mostly Early Roman IV, ca. A.D. 70-135). These soil layers were interspersed with a thin ash layer (C.10:49), and several ash pits (C.10:44, 54, 59). Several of these loci also produced a few bones.⁶⁰ Altogether, the total depth of these loci was approximately 1.15 m.

Interpretation: The scarcity of stratified evidence in primary association with the walls of C.6 and C.8 made the dating of these structures very difficult. Since Early Roman Layer C.8:34 touched Walls C.8:20, 49, 53, and Installation C.8:51, and overlay Walls C.8:37, 41, all these loci must have been earlier than C.8:34 and thus can be no later than Early Roman in date. Further, since Wall C.8:49 was a skin wall attached to Wall C.8:48, this latter wall must also have been earlier than C.8:34.

mal, 30 cattle, 2 donkey, 9 pig, 9 dog, 8 horse, 7 chicken, 1 fish, 23 undistinguishable, 431 scrap.

⁶⁰ These Early Roman loci in C.10 produced the following bones: 11 sheep/goat, 3 large mammal, 3 cattle, 1 donkey, 23 undistinguishable, 80 scrap.

The blockage loci (C.8:51, 53) in the west and north doorways must have been relatively later than their flanking walls (C.8:48, 50, 53). The west doorway probably once provided access from the southeast vaulted room of C.8 to the large subterranean installation on the west. Since Ayyūbid/Mamlūk pottery was found in all the soil layers of the room down to bedrock (perhaps indicating a Mamlūk reuse of the circular installation cut into bedrock), these earlier walls could not be dated more precisely. But the rich Early Roman occupation layer (C.8:34) to the north and the relative scarcity of pre-Early Roman pottery in C.8 suggested that these walls were perhaps of the same date.

Wall C.8:30 (=C.6:84, 31) seemed to be a westward continuation of Wall C.8:48 and thus may also have been of the same date. Since Walls C.6:84, 86 were completely covered by Early Byzantine fills (C.6: 78, 83), they were obviously no later than Early Byzantine in date. Walls C.6:86, 84 (=C.8:30), C.8:48, 50 probably served as a retaining wall for the subterranean installation. The function of the rest of the structures of this phase remained uncertain, but wall C.8:20 appeared much too massive and well built for a domestic house.

In C.10 the series of Early Roman soil layers might be interpreted as additional fill serving as makeup for the ramp. But since several of these layers ran under the Late Roman retaining wall (C.10:20) and contained almost exclusively Early Roman pottery, they were thus obviously earlier in date. The position of these layers just below the acropolis perimeter wall and its buttress in Area A, as well as the relative lack of much occupational debris, might suggest that these were erosion layers from the acropolis. The highly mixed composition of these layers also supported this suggestion. This sector of the site might also have been sporadically used for small open fires in this period, as the small ash pits (C.10:44, 54, 59) suggested. These erosion layers probably once extended further down the slope to the west, but were later cut by the ramp construction in the Late Roman period.

AREA D

LARRY G. HERR
Harvard University
Cambridge, Massachusetts

Just a few small operations remained at the end of the 1974 season for us to complete work in Area D. Since these entailed little that was new they will simply be incorporated into the following summary.¹

We have been able to separate the Area D materials into nineteen strata, some clearer and more extensive than others.² The expansion from the sixteen listed in the 1974 report³ is due to the subdivision of the Early Byzantine plaza layers extending into Area D from Area B, formerly designated as only one stratum.

Stratum 19⁴ (Fig. 9): Probably Iron I A⁵

Cistern D.1:63, coated with one layer of thick, hard, tan plaster, was dug into bedrock like a misshapen egg ca. 3.75 m. long x 2.30 m. wide x 1.75 m. deep. The original circular opening, though partially

¹ This report is intended to be a concise summary of the stratigraphy of Area D, partially excavated and interpreted by this writer, with an attempt to integrate *all* loci encountered during the past five seasons of work. Ceramics, objects, and ecological data, fully incorporated into the stratigraphy, must await the final publication. (For Square D.4, see Area B report, above.)

Editor's Note: This report does not conform to the general format for Area reports in that 1) description and interpretation are mixed, and 2) an independent sequence of strata is used and its order is reversed.

² For the overall goals and approaches to the Area see the Area D reports for the preceding four seasons: Phyllis A. Bird, "Heshbon 1968: Area D," *AUSS* 7 (1969): 165-217; Lawrence T. Geraty, "Heshbon 1971: Area D," *AUSS* 11 (1973): 89-112; id., "Heshbon 1973: Area D," *AUSS* 13 (1975): 183-202; Larry G. Herr, "Heshbon 1974: Area D," *AUSS* 14 (1976): 79-99. These are hereafter referred to under the abbreviated title of each year's excavation report, *H68*, *H71*, *H73*, *H74*.

³ *H74*, p. 82.

⁴ Stratum 16 in 1974 (see *H74*, p. 99). In the Area D independent sequence of strata, each is designated by "stratum" with an Arabic number, and is here presented from earliest to latest in time of deposit. The equivalent designation in the sitewide sequence is "Stratum" with a Roman numeral. This is Stratum XXIV.

⁵ Chronological terminology and dates follow those outlined by James Sauer in *Heshbon Pottery 1971*, AUM, vol. 7 (Berrien Springs, Mich., 1973), pp. 3 and 4, as applicable to the pottery found on the *tell*.

cut away in stratum 17, must have been ca. 0.60 m. in diameter with a neck only ca. 0.40 m. deep (as preserved) when it opened into the cistern ceiling. Just above the plaster bottom (D.1:63H) was a thin (0.06 m.) layer of dark gray, water-laid silt (D.1:63G = 101) containing a few pieces of Iron I pottery. At the end of its use it seemed the cistern was sealed off and forgotten until stratum 17. No other related features or layers were found above or near the cistern; hence a more precise relationship with the other Iron I A features at Hesbân was impossible. The paucity of the remains made it difficult to give a date more than pre-stratum 17, probably Iron I A.

Post-Stratum 19 Gap

Though Iron II deposits appeared elsewhere on the mound,⁶ nothing of the sort appeared to have been preserved in Area D, even in later debris layers. If it did exist at one time, it must have been carried away by the extensive bedrock modification of stratum 17.

Stratum 18:⁷ Iron II/Persian (7th-6th Century B.C.)

Many of the soil layers from later periods contained the Iron II/Persian pottery of stratum 18, but not one can be said to have contained nothing later than Iron II/Persian. Thus, though a stratum 18 must have existed, in Area D as well as the contemporary stratum on the rest of the acropolis, we have no structural evidence for it. Again we must blame the stratum 17 clearing operations for our loss.

Post-Stratum 18 Gap

Nothing from the Late Persian or Early Hellenistic periods was found in Area D.

Stratum 17⁸ (Fig. 9): Late Hellenistic (ca. 198-63 B.C.)

Along the south balk of D.1 a straight east-west cut was made into the existing bedrock that brought the bedrock level down vertically 1.20 m. In the process of making this cut the stratum 19 cistern (D.1:63) was discovered and filled (with Loci D.1:63C, D, E, I, J; 67, 68, 69, 100, 105, 106), and Wall D.1:104, a one-row wall surviving four courses high (Pl. IX:A), was erected to block the cistern cavity and continue the line of the bedrock cut. How far the cut went to the east and west outside our excavation limits is unknown. The opposite side of the cut (preserved only in the east) was made in D.2 ca. 3.25 m. from the north cut where, before it was robbed out in

⁶ See the reports of Areas A, B, and C above.

⁷ Stratum 15 of *H74*, p. 99. This is sitewide Stratum XXII.

⁸ Strata 14A and 14B of *H74*, pp. 96-98. This is sitewide Stratum XX.

Early Roman times, it probably also extended completely across D.2 to the west. However, it was only 0.35 m. deep here so that between the two vertical cuts the bedrock was made into a level surface.

Cut into the bottom of this large bedrock trough were three bottle-shaped, unplastered silos, two of which (D.2:77 and 95) have already been described.⁹ The third one (D.2:80), excavated this season, was smaller (1.10 m. deep x 1.85 m. in diameter) than the other two, which were ca. 2.15 m. deep x 2.50-3.00 m. in diameter at the bottom. All three had a thin but even layer of decomposed chaff or straw (D.2:77B, 95E bottom, 80E) covering the complete bottom including only Late Hellenistic pottery. One of the silos (D.2:77) contained a number of unfired clay objects, perhaps loom weights,¹⁰ while another (D.2:80) preserved a complete black, long-nozzled, Late Hellenistic lamp. Above the silos, covering the bottom of the bedrock trough, was a 0.10 m. thick series of very thin (0.002-0.005 m.) multi-colored (red, yellow, tan, and gray) surface layers, several composed of decomposed chaff with loess. The upper layers (D.2:76, 82, 86) sealed over Silo D.2:77, putting it out of use.¹¹ The other two silos were cut into by Early Roman bedrock operations. Thus the layers which originally sealed them over were removed, but a similarity with D.2:77 may be assumed.

The function of this complex was still uncertain. The presence of chaff or, less likely, straw and the orientation of the trough in perfect line with the strong west winds would suggest some kind of winnowing activity. Though it was chaff and not grain¹² in the silos, which would at first sight discourage a storage interpretation, it should be noted that the modern villagers at Heshbôn have been observed storing their retrievable chaff in burlap bags at the winnowing site. The chaff could feasibly have been used also for packing of bulky storage items such as jars, but no complete vessels or even concentrations of sherds were found; nor would this explain the chaff-covered surfaces outside the silos. The weights may attest to yet another function, though more detailed speculation about their association with bedrock pits would be fruitless. An entirely different suggestion was that the bedrock cut was a moat for the acropolis perimeter Wall D.1:4, excavated with the wall and only secondarily used as a winnowing area. But no corresponding moat has been found outside the western perimeter wall in Area A.

⁹ *Ibid.*, p. 97.

¹⁰ *Ibid.*, Pl. VIII:B.

¹¹ This was the reason for subdividing 1974's stratum 14 into two.

¹² No grain or seeds were found in the flotation samples.

Possibly related to the above trough was another bedrock cut ca. 1.00 m. farther south which leveled out 0.45 m. lower and ran into D.3 where its opposite side (if it had one) was cut off by the Early Roman bedrock operations. The exposed portion of this cut was too small to ascertain whether there were any storage installations associated with it, but the absence of thin chaff layers just above bedrock broke down the comparison with the trough to the north. In any case, a solid *huuwar* layer (D.2:109) just above the cut's bedrock bottom contained only Late Hellenistic sherds.

Three other bottle-shaped silos were found in Area D which might also have had a function similar to those mentioned above. D.3:57, just inside the north balk, had no chaff in the bottom, but its dimensions were similar to those of the D.2 installations. Though stratigraphic connections had been cut by Roman builders it should probably be considered part of stratum 17. The remaining two silos were found in D.6¹³ (D.6:47, 48) where an east-west wall (D.6:75) ran parallel to the openings and parallel with the west winds. If our favored interpretation of these installations as storage silos for winnowed chaff is correct, this may have been all that remained of another winnowing "trough" in D.6.¹⁴

This stratum saw the construction of the massive acropolis wall (D.1:4) which was used until and through stratum 3. It was founded upon bedrock on a line exactly parallel to the bedrock trough,¹⁵ but all soil connections between the wall and the trough have disappeared, except for the deep (ca. 1.25 m. near the wall to 2.45 m. in the trough) gray soil fill with Late Hellenistic pottery that closed out stratum 17 and sealed against the perimeter wall (Loci D.1:56H, 59, 60, 64, 66; D.2:74, 92, 109). Thus wall D.1:4 is certainly to be ascribed to stratum 17, but whether it was built at the beginning or near the end of that stratum's life is not clear.

Ceramic indications put stratum 17 into the Late Hellenistic period between ca. 198 and 63 B.C.

Stratum 16:¹⁶ Early Roman I (63-31 B.C.)

Only a very few fragments remained of features that must have followed stratum 17 but preceded the remains of stratum 15. Wall

¹³ See *H71*, p. 102 (Fig. 6) and pp. 107-108.

¹⁴ Similar shaped and dated silos in Areas A and B may all have been utilized in a similar way.

¹⁵ For a full discussion of the phasing and description of the wall see *H68*, pp. 170-177, 197-200; *H73*, p. 200.

¹⁶ Stratum 13 of *H74*, pp. 95-96. This is sitewide Stratum XIX.

D.1:4 certainly continued in use, while to the south the stratum 17 debris was cut into and tamped down into a gray dirt surface (D.2:74) ca. 0.55 m. above the stratum 17 bedrock trough. Lying upon this surface, and running parallel with the north balk, was a rock tumble (D.2:78) of watermelon-sized boulders which brought an end to stratum 16 and which must have originated from a wall, now almost totally disappeared, more or less in the position of Wall D.2:26 of stratum 15 and battered against the previous stratum 17 fill. Traces of this wall have appeared, beneath Wall D.2:26 (stratum 15) and aligned slightly farther north. Hence, our designation of it was Wall D.2:26B. Unfortunately, later constructions had wiped out any other means of tracing the extent of the stratum within the limits of our excavation.

North of Wall D.1:4 it was possible that the chalky *huwwar* surface (D.1:51) 0.02-0.05 m. thick just above bedrock belonged to stratum 16, though Wall D.1:4 cut any connection with the southern sector of the Area where our evidence for the existence of the stratum lay.

The rock tumble which closed Stratum 16 may have been caused by the earthquake of 31 B.C. which seemed to have wreaked such havoc elsewhere, especially in Area B.

Stratum 15¹⁷ (Fig. 9): Early Roman II-III/IV
(31 B.C. - A.D. 70?)

Wall D.1:4 again effectively broke our stratigraphy into two zones with the southern one being the chief determinant for a distinction of strata. Upon the rock tumble of stratum 16 a new east-west wall (D.2:26A) was laid with very rough, head-sized stones. Only one to two courses of the two-row wall remained, but it was high enough to have the brown, compact soil of Surface D.2:67 = 66 run up to it. Wall D.2:26 could be traced westward to within 2.00 m. of the west balk and may have run out of our excavated limits. South of and parallel to it, but constructed of much larger and better-hewn boulders, with a nicely cut threshold stone near the east balk, was Wall D.2:64, also in use with Surface D.2:67. Like Wall D.2:26A this wall may have extended farther to the west, but it was robbed out by the builders of stratum 14. As in *H74* we would again suggest a possible north-south wall roughly on the line of Wall D.2:55B of stratum 14 to account for the extensive rock tumble (loci D.2:49, 50, 59, 70 —

¹⁷ Stratum 12 of *H74*, pp. 94-95. This is sitewide Stratum XVIII.

all about head-size) which seemed to have fallen from the west and which closed stratum 15.

South of Wall D.2:64 a leveling layer (D.2:108) was deposited to bring up the level for Surface D.2:102 which was made of very hard *huwwar* plaster about 0.35 m. below the D.2:64 threshold. This probably continued (sloping down to the south) into the next Square as Surface D.3:85 (with its occupation buildup D.3:90) which ran up to a probable door jamb in Wall D.3:70. The corresponding north jamb may have been in the balk separating D.2 and D.3 while its wall may have run north to Wall D.2:64 and possibly as far as Wall D.2:26 beneath our D.2 access stairs. This proposed wall, together with Wall D.3:70, probably did not form a house, but more likely an enclosure fence for a property since it was very flimsy (four courses high survived, built one row wide of crudely carved stones except at the door-jamb where they were well-cut) and even tilted slightly westward in spite of the existence of a buttress (D.3:87).

Otherwise it may have been used to surround a large cave complex of which Area D has only a small part. Wall D.3:70 was founded on a thin shelf of bedrock which covered a deep cave (D.3:83) that extended at least 2.00 m. farther to the east. Massive slabs of bedrock (Pl. IX:B) fallen from the roof of the cave canceled our attempts to dig the cave, but the pottery beneath a few of the slabs (in loci D.3:107, 108, 109) showed that it was at the end of this stratum (not stratum 16) that the collapse had occurred. It is probable that some carved bedrock steps (D.3:103) in the southern central portion of D.3 leading down northward represented the entrance to the cave, but unfortunately, the presence of Wall D.3:16 of stratum 14 separated any connection. Other caves in D.3, D.4, and Area B may have been part of this underground system.

Beside the rock tumble and cave collapse heralding the end of stratum 15, various soil layers also covered the remains: Loci D.1:53, 55, loose, gray-brown to red soil; D.2:63, brown, rubbly soil; D.2:62, 71, 75, 79, mostly brown to gray colors with crumbly to fairly compact textures; D.3:54, 55, 61, 62, all tumbled around toppled bedrock slabs in the west; and D.3:99, 101 — tumble above the steps. This destruction seemed to have been caused by an earthquake or a violent destruction strong enough to cause the collapse of the cave in D.3.¹⁸

¹⁸ The Jewish raids during the early years of the first revolt (see *JW* 2.18.1) could have been the cause of the destruction, though the collapsed bedrock of the cave ceilings would favor an earthquake. Unfortunately none are recorded between A.D. 48 and 130 (see D. H. Kallner-Amiran, "A Revised Earthquake-Catalogue of Palestine," *IEJ*, 1 [1950-51]: 225). The latter date could

North of Wall D.1:4 certain connections with the southern zone were impossible, but Surface D.1:49, made up of plaster including limestone chips, may have belonged to stratum 15. The equivalent surface in D.6 was the white plaster Surface D.6:45 which sealed silos D.6:47 and 48 and thus their original fill (though later contaminated by stratum 4 see below) seemed to belong to the beginning of stratum 15.¹⁹ The same surface sealed against Wall D.6:46 — an east-west wall 0.85 m. wide in the northern limits of Area D — which may have extended farther to the east and west than preserved. Like Wall D.3:70 it may have only been a fence wall.

Stratum 14²⁰ (Fig. 9): Early Roman IV (A.D. 70²-135)

With stratum 14 we had the first significant architectural remains south of Wall D.1:4, when a completely new city was rebuilt, this time wholly above ground. Along with the construction of Wall D.3:16 = D.2:55A = D.4:32²¹ a massive fill containing Early Roman II-IV ceramics was deposited to the east covering the remains of stratum 15 (Loci D.3:66, 71, 73, 78, 79, 80, 82, 86, 88, 89, 91, 93, 102, 105; D.2:23, 27). There were no surfaces among these layers; rather pockets of loose rubble and soil were characteristic for a depth of up to 4.25 m. in the northeast of D.3 where the bedrock collapse of stratum 15 was covered. The top 0.30 m. of this fill was multi-layered with sifted soil and pebbles as if each layer had been exposed for a short time, but never allowed to become a *bona fide* surface. Perhaps this was the result of off-and-on seasonal rains during the final stages of the filling operations. This season a black three-spouted lamp, exposed by erosion since 1974, was found within the fill. On top of this

be remotely possible since some Early Roman IV pottery (considered post-A.D. 70 in date by Sauer in his monograph *Heshbon Pottery 1971*) appeared surrounding some of the collapsed bedrock slabs and in the makeup for the stratum 14 ramp (see below), here interpreted as gathered from the destroyed stratum 15 debris. This left us already in Early Roman IV by the end of stratum 15. However, the late date of A.D. 130 left us a very short time span for the Early Roman IV, stratum 14, even though in Area D, as elsewhere, this stratum was the thinnest (by a considerable margin) of all similar strata which followed. It may be possible as well that stratum 14 extended slightly into the Late Roman period by a number of years. Yet another possibility is that an unrecorded earthquake occurred at some time toward the end of the first century A.D. and may have been the one responsible for our destruction.

¹⁹ See *H71*, pp. 92-94.

²⁰ Stratum 11 of *H74*, pp. 92-94. This is sitewide Stratum XVII.

²¹ Two phases were noted for this wall, especially in D.3; D.3:16A belonged to stratum 13 and was a rebuild of stratum 14's D.3:16B, slightly farther to the west so that it overhung 16B.

earthen buildup a hard white plaster layer (similar to those in Area B) was laid sloping upward (D.2:22 = D.3:19 = D.3:67). The 1974 interpretation²² of this as a ramp was further supported this season by the discoveries in D.4,²³ which, though not conclusive, tended strongly in this direction. The partial removal of the east end of the D.3-D.4 balk saw the ramp's plaster layers run up to Wall D.4:31-D.3:117, which was a retaining wall (faced on the south, unfaced on the north) for the south end of the ramp. Presumably the entrance to the ramp would have been east of our excavation limits.

Wall D.3:16B = D.2:55A was formed of large boulders only slightly worked perhaps because it was only an inside retaining wall not meant to be exposed to the eye.²⁴ Much better worked were the ashlar stones making up the lowest course of Wall D.3:47 = D.2:104 = D.4:83, which was parallel to and in use with Wall D.3:16B, but which faced the plaza of Area B.

Since this stratum has been described in the 1974 report, here we will add only a few refinements and corrections. It would seem that in the sector which had the rooms in D.2 and D.3 the silos, originally cut in stratum 17, were filled (D.2:80C, D; D.2:95C, D, E; D.3:57A, B, C, D, E, F),²⁵ since their ceramics were identical to those of the ramp buildup. Possibly to fortify the fill above Silo D.3:57 for the surface of the room above, Wall D.3:63 was constructed, probably of large stones robbed from an earlier structure.

Above the foundation trenches for Wall D.3:47 (D.3:53, 56) Surface D.3:52 (dark gray to light gray compact soil) was laid which ran between and up to Walls D.3:16B and 47. The stratum 14 surfaces in D.2 seem to have been removed by the stratum 13 occupants. Indeed, there was little evidence that the D.2 room existed in stratum 14 since all soil layers and walls, except Walls D.2:21 and D.2:111 (which blocked Silo D.2:80 for use with the room and which had the stratum 14 soil Layer D.2:80C seal up against it) were no earlier than stratum 13. It may have been that the stratum 14 room if it existed was not cut into bedrock as deeply as that of stratum 13.

²² *H74*, pp. 92-93.

²³ See the Area B report, above.

²⁴ Compare the levels of the ramp in the north of D.3 (889.08 m.) with the corresponding floor west of Wall D.3:16 (886.90 m.).

²⁵ It should be mentioned that these layers (containing head-size and smaller stones with loose dirt) seemed to have been the result of rapid fill at one time and do not support the conclusions of LaBianca and LaBianca, "Domestic Animals of the Early Roman Period," *AUSS* 14 (1976): 205-216, where quite indistinct layers in Silo D.3:57 were overemphasized as distinct strata. The best interpretation for the fill of D.3:57 is that of a garbage dump.

North of the rooms but south of Wall D.1:4 only fill debris was encountered (D.1:53, 55, 56A — brown to gray, loose layers) into which the crude Drain D.1:61 = 80 was laid.²⁶ North of Wall D.1:4 the drain continued, probably in use with, or built from, a rather indistinct dirt surface (D.1:82 and D.1:81 = 46) laid atop ca. 0.60 m. of leveling debris (D.1:47, 48, 86, 87, 88, 92 — all varying degrees of rubble and loose dirt) and the foundation trenches for Drain D.1:61-80 (D.1:84, 85). The soil within the drain (D.1:89) did not seem to have been water-laid, but rather sifted down through the capping stones.

Stratum 14 probably saw the first digging of Cistern D.6:33 since its foundation trench (D.6:73) was sealed by the dirt Surface D.6:44, which may be considered part of stratum 14.

Very little indication remained as to what brought about the close of stratum 14, but some debris was found (Layers D.1:79 and D.6:71). The destruction or renovation may have been due to the A.D. 132-135 Bar Kochba revolt which closed the Early Roman and began the Late Roman period.

Stratum 13²⁷ (Fig. 9): Late Roman I-II (ca. A.D. 135-235)

The stratum 14 walls had been destroyed or dismantled to ground surface level and were now rebuilt along the same lines. Wall D.3:47 was again built of ashlar stones, but a new set of foundation cobbles was laid above the stratum 14 courses. It was to stratum 13 that the well-worn thresholds in Wall D.3:47 belonged. Wall D.3:16A was constructed of large, poorly-worked boulders, but was founded ca. 0.10 m. farther to the west than Wall D.3:16B. Its foundation trench into the stratum 14 ramp buildup was clear (D.2:68 and D.3:75, 77, 104). After a layer of leveling debris was laid down to cover the stratum 14 destruction (D.3:97) Surface D.3:49 = 95 was laid connecting both walls (D.3:47 and D.3:16). In a possible second room in the north of D.3, Surface D.3:60 was laid, again running up against both walls.

It is probable that a more thorough renovation occurred in the room in D.2 where the stratum 14 surface (if one existed) was completely removed and Surface D.2:89 (= D.2:94, 98, 101, 112) was laid directly above bedrock and on top of leveling debris in Silo D.2:95 (D.2:95A, B) and the southern Wall D.2:85's foundation trench (D.2:91), indicating that this wall may have belonged completely

²⁶ See H74, p. 92 and Pl. VIII:A for a description.

²⁷ Stratum 10 of H74, pp. 87-91. This is sitewide Stratum XVI.

within stratum 13. The skin Wall D.2:21A was partially dismantled this season revealing pottery of stratum 13²⁸ while nothing earlier than the same ceramics could be found running up to the west wall (D.2:81). Further, the eastern wall, D.2:55B, though containing stratum 14 pottery, appeared to have abutted against skin Wall D.2:21A of stratum 13. Thus it seemed that all four walls of the D.2 room, from their founding on, belonged to stratum 13. The somewhat disjointed relationship of the D.2 room to the D.3 walls (where the stratum 13 walls carefully followed stratum 14 lines) may indicate its secondary nature as well.

East of the rooms another white plaster layer (D.3:18), very hard and compact ca. 0.11 m. thick, was laid to resurface the ramp, into which at least one pit had been dug (D.3:76). It was used as in stratum 14, but with a few changes to its approach in D.4.²⁹ This was probably soon resurfaced with another white layer (D.3:8).

The end of the stratum saw a massive destruction, preserved beneath the stratum 12 stairway in D.2 to a depth of up to 3.25 m. (including rubble and rock tumble loci: D.2:31, 42, 43, 58, 69, 72, 73, 88, 90, 100, 107; D.3:96, 116). The distinct layering (Pl. X:A) of the rock tumbles on top of each other within the D.2 room may have been an indication of a roof and/or a second story. Rock Tumble D.3:48 = 94 represented the destruction of Wall D.3:16.

We were again uncertain of connections to the north of Wall D.1:4, but it was possible that the earliest Late Roman remains there dated to stratum 13. In D.1 leveling debris was brought in to prepare for dirt Surface D.1:44, better preserved in the east than in the west, while an enigmatic stone construction, D.1:45 (buttress for Wall D.1:4[?]), was used in conjunction with Surface D.1:44. Cistern D.6:33 also seemed to have continued in use.

The earliest Late Roman pottery was found in and just beneath the surfaces of stratum 13, dating its beginning to the mid-2d century A.D., while the very substantial debris which closed out the stratum was dated to the late 2d century.

Stratum 12³⁰ (Fig. 9): Late Roman III-IV (ca. A.D. 235-324)

Since this stratum south of Wall D.1:4 has been described in the 1973 and 1974 reports,³¹ little will be said here beside a listing of the

²⁸ Wall D.2:111, built to wall up Silo D.2:80 and in line with skin Wall D.2:21A, also contained pottery of stratum 13.

²⁹ See the Area B report above.

³⁰ Stratum 9 of H74. This is sitewide Stratum XV.

³¹ H73, pp. 196-199 and Fig. 8; H74, pp. 85-87.

loci involved. The monumental Stairway D.2:32 = D.3:39 (for its westward continuation in B.7, see the Area B report, above) had a very substantial makeup (Loci D.2:24, sub-32, 36, 40; D.3:43, 50, 51, 58, 59; D.1:57 — well-packed dirt with hewn and/or unhewn stone-tumble layers) above the debris from the stratum 13 destruction.

Wall D.2:21 was probably the northern limit of the stairway whence a platform (destroyed at a later date) ran to the gateway in Wall D.1:4, perhaps larger than now apparent. The stairway reused Walls D.3:16A and D.2:55A (and probably B) as its eastern boundary while a succession of plaster surfaces from the Area B plaza ran up to the bottom steps (Surfaces D.3:40, 44, 45, 46 = 92). The sector east of the stairway seems to have been abandoned except for a small pit along the east balk (D.3:114, 115) that cut into the ramp layers of strata 14 and 13.

The material was still scanty north of Wall D.1:4 but leveling debris (D.1:76, 93) was probably preparation for clayey Surface D.1:35 = 75 which included a *ṭabun* indicating its possible function as an open courtyard. East-west Wall D.6:19, at least a meter wide, founded on bedrock, and Late Roman in date, may have been built at this time as well as the two one-row, two-course, north-south walls (D.6:39 and 41) abutting D.6:19 on the north. These may have been used only to structure the fill (Loci D.6:40, 42, 69) which surrounded them for a surface above no longer extant.

The Late Roman Layer D.5:49 (compact, dark brown soil just above bedrock) may have belonged to stratum 12. If so, this was the earliest evidence for Cistern D.5:5³² (which continued until stratum 3), since it ran up to the cistern's vaulting. Along with Cistern D.6:33, we could thus envisage two large cisterns on the southeast side of the acropolis in stratum 12.

Though lacking in the rest of Area D because of later robbing, there seemed to have been quite a massive destruction at the end of stratum 12 since the tumble from Wall D.3:16A was 1.25 m. deep near the wall, thinning out to 0.40 m. near the west balk.

Stratum 11.³³ Early Byzantine I (ca. A.D. 324-340)

The only evidence for this stratum was the resurfacing of the Area B/D plaza layers in use with Stairway D.3:39. A white plaster surface (D.3:38) was laid atop the stratum 12 destruction debris and ran up

³² See *H71*, pp. 97-99 and Fig. 5.

³³ Included within stratum 9 of *H74*. This is sitewide Stratum XIV.

to the fourth course of Stairway D.3:39. The evidence for any attempt to rebuild Wall D.3:16, at least in the north, was removed by a large stratum 3 pit. South of the stairs the stratum 11 surface seemed to have continued up and over the remains of Wall D.3:16 running out of our excavations to the east.

There was no evidence for any change of activity elsewhere in Area D, except perhaps a small pit in the southeast corner of D.3 (D.3:113) which cut through the strata 13-14 ramp layers. Cisterns D.5:5 and D.6:33 probably continued in use, but no soil layers within the cisterns positively attested that supposition.

There was a lack of any real destruction in Area D for bringing stratum 11 to an end. Perhaps it occurred elsewhere: the 0.50 m. of soil (part of D.3:33) between the strata 11 and 10 plaza surfaces was too great to be considered a simple resurfacing. We followed the breakdown of the Early Byzantine dating of this stratum and the next three worked out for Area B.³⁴

Stratum 10:³⁵ Early Byzantine I (ca. A.D. 340-350)

Again, the information for this stratum came only from D.3 south of Stairway D.3:39, where another plaza surface (D.3:33) was laid, which could not be traced up to the stairway in D.3 because of the stratum 8 pit, but which did run up to the stairway in B.7.³⁶ A tendency for the surfaces to rise up from the south toward the stairs began here and continued into stratum 9. At the end of stratum 10 several layers of debris accumulated (D.3:24, 25, 36 — all reddish-brown soil with *nari* chips), though the accumulation seems to have been rapid since no exposure surfaces were found. The pottery was solidly Early Byzantine, and following the dating of Area B, was placed in the mid-4th century A.D.

Stratum 9:³⁷ Early Byzantine I (ca. A.D. 350-365)

Like strata 10 and 11 this stratum was basically a plaza surface, again using Stairway D.3:39, though our only connection with the stairway was in B.7 where, though cut by the stratum 8 (Area D) pit, the probability of its connection with the stairway was deduced.³⁸ A makeup layer of reddish brown soil was spread over the uneven

³⁴ See James Sauer, on Area B strata 9-5, in *H71*, pp. 57-61.

³⁵ Included within stratum 9 of *H74*. This is sitewide Stratum XIII.

³⁶ See the 1976 Area B report in this issue.

³⁷ Included within stratum 9 of *H74*. This is sitewide Stratum XII.

³⁸ See the Area B report in this issue.

soil (D.3:11) and then a plaster surface (D.3:10) laid over it. A very extensive rock tumble (D.3:13) covering most of Area B as well as D.3, and ascribed by Sauer³⁹ to an earthquake in A.D. 365, put an end to the stratum.

Stratum 8⁴⁰ (Fig. 9): Early Byzantine II-IV (ca. A.D. 365-450)

The destruction from the A.D. 365 earthquake demanded a large-scale rebuilding operation. A large pit was dug to excavate the well-cut stones from the strata 12-9 stairway for re-use in another stairway (Pl. X:B) encountered in Area D as D.2:34. The pit was then filled (Locs D.3:26, 27, 28, 29, 30, 31, 32, 34, 35, 41, 42 — a series of thin, interlacing fill layers tipped down from north to south and composed of tan soil with *nari* chips) and Surface D.3:12 = 3 = D.2:18 was laid on top and ran up to the bottom step of the D.2:34 stairway.

It was at this period that the well chiseled Byzantine courses on Wall D.1:4 were probably added, though no surviving soil relationships made this certain.⁴¹

North of Wall D.1:4 it is probable that the earliest construction of the Area A church was begun.⁴² In Area D this included the south wall of the church (Wall D.5:12 = D.6:55) and the room south of the apse (made up by Walls D.6:3C and 19C), as well as Wall D.6:56C, thus possibly forming a room with Wall D.6:3C to protect Cistern D.6:33, which continued in use probably along with Cistern D.5:5. All stratum 8 surfaces seemed to have vanished in the rebuilding of the church and associated structures in stratum 7.

Stratum 7 (Fig. 9): Byzantine (ca. A.D. 450-614)

This stratum has been completely described in the 1973 and 1974 reports;⁴³ so this summary will be very brief. With stratum 7 it is possible to connect the loci north and south of Wall D.1:4 by Drain D.1:58/77 = D.2:30 (the drain walls were labeled D.1:78, 83), which ran along the west balk and beneath Wall D.1:4. South of Wall D.1:4 it was capped by Wall D.1:37 = D.2:25 as it cut through the top courses of Stairway D.2:34, still in use from stratum 8. Surfaces D.1:31 = D.2:13B/20/33 were laid up against it atop a slight makeup

³⁹ See Sauer on Area B in *H71*, pp. 58-60.

⁴⁰ See *H73*, pp. 191-196, where our strata 7 and 8 are combined. These are Strata IX-XI.

⁴¹ See *H68*, p. 170.

⁴² All wall and foundation-trench phases (Locs D.5:29 = 47; D.6:76) are described in *H73*, pp. 191-192; *H74*, pp. 84-85.

⁴³ *H73*, pp. 191-196 and Fig. 7; *H74*, pp. 84-85. This is sitewide Stratum VIII.

AREA D

STRATUM 19

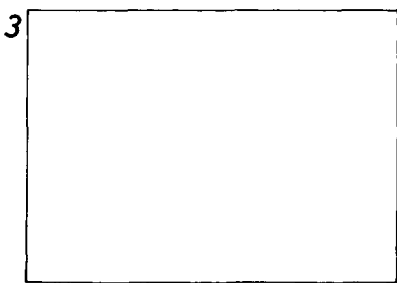
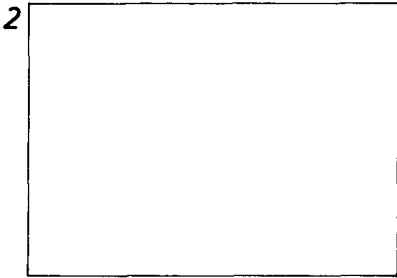
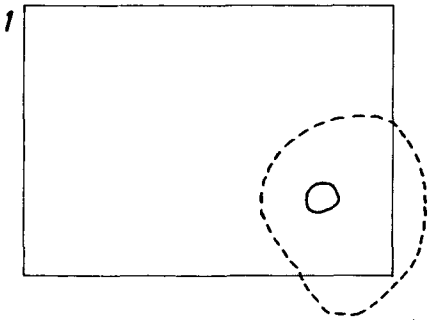
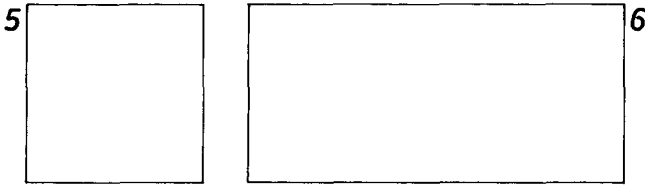

HESHBON 1976
 AREA D STRATA

DRAWN BY LARRY HERR & BERT
 DEVRIES

KEY:







-  WALL
-  INSTALLATION
-  SURFACE
-  DEBRIS ABOVE SURFACE
-  DEBRIS BELOW SURFACE
(leveling)
-  HIDDEN OR RECONSTRUCTED



Fig. 9. Schematic plans of Area D's independent sequence of strata.
 (Continued on foldout)

layer (D.1:38). North of the perimeter wall the fine dolomitic limestone tile Surface D.1:41 = 73 was laid atop a red, compact leveling layer (D.1:43 = 74). This floor ran up to east-west Wall D.5:27 = D.6:70, which in turn was contemporary with Walls D.5:12 = D.6:55, D.6:56B, D.6:3C, and D.6:19C.

The western room formed by these walls had a combination flagstone (D.5:42) and hard plaster floor (D.5:13 = 17 = 35) laid atop various compact makeup layers and pockets: D.5:18, 19, 21, 23, 25, 26, 28, 29, 43, 44, 46, the latter five of which made up the foundation trench (replete with tesserae and fresco fragments, probably from the stratum 8 church) for the second phase of the south church wall, D.5:12. Also beneath this room's surface was the western foundation trench for Wall D.6:56B (D.6:66). Embedded in and below the pavement floor was the drain (D.5:20; side walls: D.5:16, 38, 39; soil inside: D.5:40) which apparently led from two downspouts along the church wall to Cistern D.5:5.

The eastern room had Surface D.6:61A laid atop a hard, reddish leveling layer (D.6:62) and the east foundation trench for Wall D.6:56B (D.6:67) as well as the foundation trench for Wall D.6:70 (D.6:74). Drain D.6:63 (interior soil: D.6:63A, B) led from the church's eastern downspout into Cistern D.6:33. Surfaces east of Wall D.6:3C were probably destroyed in preparing the stratum 6 tessellated floor.

The function of the rooms north of Wall D.1:4 was not indicated by any of the finds. Perhaps they were rooms associated with the church. A dating span from ca. A.D. 450 to 614, though long, would seem defensible.⁴⁴

Stratum 6⁴⁵ (Fig. 9): Late Byzantine (A.D. 614-661)

The only major difference between strata 6 and 7 was the construction of the flagstone Pavement D.1:33/34 = D.5:11 along with its several, thin layers of makeup (D.1:50 = 70, 50B = 71, 50C = 72; D.5:24, 32, 34, 36, 37) above the floors of stratum 7. Wall D.5:27 = D.6:70 was dismantled and paved over, forming a large open court bounded by Walls D.1:4, D.5:12 = D.6:55, and D.6:56A, in which Cistern D.5:5 was reused and still fed by the stratum 7 drains.

⁴⁴ See *H74*, p. 84, for the reasoning behind the closing date given here. The beginning date was not more specific than the possible connection of the B.1 kiln, ca. A.D. 450 (see Sauer, "Area B," *H71*, pp. 44-48), with the construction of the church.

⁴⁵ See *H73*, pp. 189-191; *H74*, pp. 83-84 for a more detailed discussion. This is sitewide Stratum VII.

East of Wall D.6:56A a new surface (D.1:36 = D.6:57 = 58) was laid in the small room housing Cistern D.6:33. East of Wall D.6:3C the tessellated floor D.6:23 was laid atop three thin makeup layers (D.6:35, 37, 38).

South of Wall D.1:4 the platform at the top of the stairway was resurfaced (D.1:30) just in front of the gate through Wall D.1:4, while the drain and stairway continued in use from stratum 7.

The end date of stratum 6 was difficult to pinpoint since the changes to stratum 5 did not seem to have been violent: no overlying debris or destruction could be found; the stratum 5 surfaces seemed to have reused (or been laid immediately above) those of stratum 6. The change to the Umayyad period seems to have been peaceful. Indeed, if it were not for a few definite architectural changes there would hardly be a cause to change strata. Stratum 6 could then have carried over into the Umayyad period.

Stratum 5⁴⁶ (Fig. 9): Umayyad (ca. A.D. 661-750)

The flagstone pavement of stratum 6 seems to have been reused in the Umayyad period since a few Umayyad sherds were found in the flagstone joints. The silt inside some of the stratum 7 drains had one or two Umayyad sherds, indicating their continual use into stratum 5.

Two north-south walls (D.1:15 = D.5:9 and D.1:24 = D.6:54) effectively divided the sector north of Wall D.1:4 into three separate zones. West of Wall D.1:15 = D.5:9 Pavement D.5:11 was reused in the north, while in the south, near the gate, occupational deposits (Surfaces D.1:12B, C, D) accumulated on top of the pavement. In this sector Cistern D.5:5 was still in use along with Drain D.5:20.

Between Walls D.1:15 = D.5:9 to the west and D.1:24 = D.6:54 on the east, two east-west walls seemed to have subdivided this central portion into three parts. North of Wall D.6:65 was Surface D.5:10 = D.6:52, partially atop pavement D.5:11, connecting Walls D.5:12 = D.6:55, D.5:9, D.6:54, and D.6:65. The southern part had Surface D.1:33/34 used with Walls D.1:32, 15 and 4, but was cut off before it reached Wall D.1:24 by the foundation trench for Wall D.1:3 of stratum 3. The central sector was probably two rooms of unknown use with a central hallway. To the east, Surface D.6:53 ran up to Walls D.6:54, 55, 3B and D.1:25 as well as Cistern D.6:33 and its drain (D.6:63). South of the small (one row, one surviving course) Wall D.1:25 was Surface D.1:27, which ran against Wall D.1:26 (similar to D.1:25). In the small room thus formed was a small *ṭabun* indicat-

⁴⁶ See H73, pp. 188-189 and Fig. 6. This is sitewide Stratum VI.

ing domestic use. South of Wall D.1:26 was a very small room floored by Surface D.1:28. East of Wall D.6:3B and north of Wall D.6:19B was Surface D.6:21B, probably an outdoor surface. The general picture one got was of a domestic space, possibly entered from the east through Wall D.6:3B and from the west through Wall D.1:15 = D.5:9. The front entrance was probably on the west, facing the flagstone pavement. The central sector probably consisted of living rooms while the portion to the east was most likely used for household work (the cistern and the *ṭabun*).

South of Wall D.1:4, the stratum 8 stairway seemed still to have been in use along with Drain D.1:37 = D.2:30. Wall D.1:10B = D.2:2 was erected just east of the drain, incorporating a column (from the Byzantine church?), possibly to make a boundary for the stairway. Surface D.1:23 = D.2:13A spanned the gap from the top of the stairway to the gate through Wall D.1:4.

The stratum 5 city seemed to have been abandoned, since no destruction was evident, unless the debris was denuded in the post-stratum 5 gap. Only a few soil layers (D.1:39, 50A; D.2:12; D.6:50) separated the stratum 5 surfaces from the stratum 4 surfaces. It is possible that the abandonment occurred when the Umayyad period ended, as the wealth and influence surrounding the Caliph moved to Baghdad. A good date for the end of stratum 5 would thus be ca. A.D. 750.

Post-Stratum 5 Gap

Though sprinklings of 'Abbāsīd pottery were found, nowhere in Area D was it isolated as a distinct layer or phase. Likewise, nothing was found of the Fatimid, Seljuk, or Crusader periods.

Stratum 4⁴⁷ (Fig. 9): Ayyūbid (ca. A.D. 1200-1260)

No significant occupation took place in stratum 4, though a few pre-stratum 3 surfaces (D.1:22, D.6:52, 21A) existed north of Wall D.1:4 and sealed against Walls D.5:12 = D.6:3B, and D.6:19. It seemed that these surfaces were used around the ruins of the stratum 5 walls when water was drawn from the newly cleaned Cisterns D.5:5 and D.6:33, though no channels or drains were observed leading into them. Perhaps the stratum 7 to 5 drains were reused, but no indication of such has come down to us. A *ṭabun* next to Cistern D.6:33 indicated slight domestic use.

South of Wall D.1:4 it seemed that Wall D.1:10B = D.2:2 still was

⁴⁷ H73, p. 187. This is sitewide Stratum IV.

visible. All other stratum 5 walls seemed to have been covered by debris and were not visible during stratum 4.

The picture one got of stratum 4 was that of very light use, perhaps semi-nomadic. By the pottery from the earliest fill layers in Cistern D.6:33 (D.6:33G, H, I) it seemed to date to the Ayyūbid period, the first half of the 13th century A.D.

Stratum 3 (Fig. 9): Early Mamlūk (ca. A.D. 1260-1400)

Stratum 3 has been almost completely reported elsewhere,⁴⁸ but its character covered in three different seasonal reports could be understood better through a brief overview of all the loci involved. South of Wall D.1:4 Walls D.1:10A = D.2:3B (with a threshold roughly in the center), D.2:9, and D.1:4 formed the boundary of a probable courtyard surfaced by *huwwar* (D.1:17, 21 = 54; D.2:10). It lay atop a large robber pit (fill loci: D.2:15, 16, 17, 19, 28, 29, 38, 39, 41, 48, 52, 53, 54, 56, 57, 60) dug to gain building materials from the strata 13-9 walls and stairways. In the southwest corner of this courtyard was a small enclosure (ca. 2.00 x 1.50 m.) surrounded by the one row, one surviving course Wall D.2:11 forming a possible storage zone. South of the courtyard and also covering the large pit (fill Loci D.3:9, 15) was *huwwar* Surface D.2:8 = 14 = D.3:6 = 7.

To the west, Stairway D.2:7 (Pl. X:B), built atop the previous stairways, ascended from the D.3 surface to a plaster platform (D.1:11, 13) outside the gate through Wall D.1:4. Just inside the gate to the north was an open space with a reddish dirt surface (D.1:12A = D.5:7) topping some leveling debris (D.5:8, 14) and small pits (D.5:33, 41).

Inside the vaulted room formed by Walls D.1:4, D.1:3 = D.5:2, D.6:3A = D.1:5 were two phases of surfaces: Laid atop some leveling debris (D.6:3B, 49, 51) was a hard-packed, brown earth surface (D.6:31); built upon this surface were three ephemeral (one course, one row) north-south walls (D.6:28, 30, 32) that may have been benches, cupboards (a bowl was found between two of them), or simply a retention of the leveling debris (D.6:27) for the black, ashy surface above (D.6:26). The southern part of the floor of the vaulted room seemed to have been slightly lower (ca. 0.20 m.) than the north during the first phase (Surfaces D.6:31 and D.1:14). Thus Step D.6:29 was needed to communicate between the two parts. With the laying of the second phase (Surfaces D.1:20 and D.6:26) the southern part was only 0.10 m. lower and no step was needed. It was probably with

⁴⁸ See *H68*, pp. 197-203 and Pl. XX:A; *H71*, pp. 94-110; *H73*, pp. 184-187 and Fig. 6; *H74*, pp. 81-83. This is sitewide Stratum III.

this second phase that Cistern D.6:33 was filled (D.6:33A, B, C, D, E, F) and closed, since the latest coins found inside were from the mid-14th century. Lining this room on the south and built against Wall D.1:4 was Bench D.1:8. The north wall, D.6:68, probably rose no higher than the inner surfaces, making the north side of the room open.

East of Wall D.6:3A no surface could be found, but Pit D.6:43, possible Bin D.6:18, and the bins built into Wall D.6:19 attested possible storage use.

Wall D.1:4 with its gate was probably the outer wall of a Mamlūk caravanserai. Inside the gate was a courtyard, including Cistern D.5:5, with a vaulted room,⁴⁹ and a probable storage zone to the east. South of Wall D.1:4 were outlying buildings and the approach to the gateway.

At the end of its active use, stratum 3 did not appear to have been destroyed. Stratum 2 seemed to have been laid on top of very little accumulation (D.1:6, 7; D.6:16, 20). A good reason for the abandonment still eludes us.

Stratum 2⁵⁰ (Fig. 9): Late Mamlūk (ca. A.D. 1400-1456)

The discoveries from this stratum, spread over the reports of various seasons, will also receive a brief summary of the loci involved. In the eastern part of D.6 a series of terraces included east-west Wall D.6:61 holding back layers D.6:13 and 14 (Terrace III) and east-west Wall D.6:12 (which ran into a cobble pocket, D.6:11, on the east) which held back a series of two terraces going from east to west: Layer D.6:10 was below them and to the east; Wall D.6:8 held back Layers D.6:9 and 10 (Terrace II); Wall D.6:7 retained Layers D.6:6 and 10 (Terrace I). On the north side of these terraces was Wall D.6:60 running along the north balk. All terrace walls were one surviving course high and one row wide; all soil layers were loose and sandy except for D.6:10, the layer upon which the terraces were built.

The vaulted room of stratum 3 seemed to have continued; but no surfaces were found, only debris layers D.1:39 and D.5:3, 4, 6, possibly from the end of the stratum. At this time Cistern D.5:5 was filled (D.5:5A, B, C, D, E) and abandoned.

The gate through Wall D.1:4 was blocked (D.1:9) while south of the perimeter wall it was possible that the courtyard continued in

⁴⁹ See the Area A report in this issue for much more material from this Stratum.

⁵⁰ See *H68*, pp. 212-216; *H71*, pp. 104-105; *H73*, p. 184. This is sitewide Stratum II.

light use as a terrace with Wall D.2:3A retaining Surface D.2:4 = D.1:16 atop leveling debris (D.1:19). West of the courtyard was an exposure (non-occupation) Surface D.2:5 = 6 = D.3:5. In the west of D.3 was an "L"-shaped wall (D.3:3, 4), perhaps another terrace, field enclosure, or house, while a series of pits disturbed the south portion of D.3 (D.3:14, 17 = 111 = 112).

The picture we got of stratum 2 was that of a village of irregularly spaced houses along with their gardens and open zones, much like parts of the modern village of Ḥesbân.

At the end of stratum 2 occupation, the vaulted building and the other various walls began to fall down (Tumble D.6:5; D.5:3, 4, 6; D.1:39). The appearance of the debris was one of gradual disintegration and buildup after abandonment rather than the sudden accumulation of a deliberate destruction. The half-preserved vaulted room suggested this. Stratum 2 was in the Late Mamlūk period, perhaps ca. A.D. 1400-1456.

Post-Stratum 2 Gap

Nothing in Area D was found to hint of any Ottoman occupation, ca. A.D. 1456 to 1870.

Stratum 1: Modern (1870-Present)

With the modern village of Ḥesbân largely ignoring the acropolis region of the site, all that we have found from the Modern period were a few objects in topsoil, but no architecture or stratified remains.

AREAS F and K

JOHN J. DAVIS

Grace Theological Seminary
Winona Lake, Indiana

Tomb exploration in the 1976 season was concentrated mainly in Area F, on the southwest slope of Tell Heshbân, where six rock-cut tombs and one cave were examined. Work originally began in this region during the 1971 season and was continued in 1973 and 1974.¹ In an effort to locate possible Iron Age burials, cave exploration and probes were undertaken on the western slopes of Tell Heshbân. Three caves were excavated and one proved to be a burial site, but not attributable to the Iron Age.

Two shaft-type tombs were examined on the hill immediately to the east of Tell Heshbân and one (K.1) was completely excavated.

All tombs were excavated stratigraphically, both inside and in the sector immediately adjacent to the entrance. Sections developed against exterior faces of the blocking stones and entrances helped to confirm the sequence of tomb use through various periods of history. Attention was also given to architectural features of the various tombs and the tool technology employed to cut them. All soil was carefully sifted by locus in order to assure recovery of very small objects and bone fragments.

The three tomb types examined in Area F included (1) the single chamber type with loculi (Heb. *kôkîm*) radiating from its walls, (2) the vertical shaft type in which the bottom was widened out along each side forming arcosolia with either trough-graves or a flat floor, and (3) a single-chamber tomb

¹ S. Douglas Waterhouse, "Heshbon 1971: Areas E and F," *AUSS* 11 (1973): 113-125; Dewey M. Beegle, "Heshbon 1973: Necropolis Area F," *ibid.*, 13 (1975): 203-211; James H. Stirling, "Heshbon 1974: Areas E, F, and G.10," *ibid.*, 14 (1976): 101-106.

without the presence of loculi. Tomb K.1 followed the pattern of the deep-shaft type tomb which was common to Area F in the Byzantine period, and this featured three distinct parallel burial troughs.

Tomb F.27 (Fig. 10)

A series of probes utilizing a long steel rod indicated the presence of two vertical faces, the eastern one giving evidence of some type of protrusion, possibly the stone blocking an entrance of a tomb. Excavation proved this suspicion to be correct. Unfortunately, the entrance had been broken open by modern tomb robbers. The original sealing stone was still *in situ*, but the top third of it had been removed and the entrance was last sealed with six large field stones, apparently hastily dumped over this opening so it could be backfilled. It was clear from this characteristic that the tomb had been robbed in recent times. That suspicion was confirmed by initial examination of the interior which was badly disturbed through clandestine activity—evidenced further by an empty cigarette package resting in the lamp niche between two loculi.

In spite of the fact that the tomb had been badly disturbed, a stratigraphic sequence for its use was determined. Its architectural uniqueness made further study worthwhile. The tomb was of a square-chamber type with eight loculi cut into the sides at irregular angles (see Fig. 10). One loculus was situated on each side of the entrance and the remaining six were on the south and east chamber walls. An unusual feature was the presence of a subchamber cut from the west chamber wall on the same level as the loculi but with three troughs in its base that were originally covered with gable-shaped sarcophagus lids, one of which was still in place (see Pl. XI:A). The lids averaged 1.00 m. in length, 0.62 m. wide and 0.22 m. thick at the highest point of the triangle.

Like earlier Roman tombs discovered, this had a square-cut depression in the floor of the tomb. But unlike those in earlier Roman tombs, this square was quite large, leaving very little ledge immediately in front of the loculi, and no ledge on the north side.

The square pit, which was common in the tombs of both the Early and Late Roman periods, has been variously interpreted. E. L. Sukenik suggested that their purpose was “. . . to allow head room within the chamber, without the labor which would have been involved in cutting the whole floor area to the required depth”; also that the

benches which surrounded the pit area could accommodate the deceased before being placed inside a *loculus*.² Robert Smith maintained that the benches which surrounded the depression were used as a shelf for funerary objects.³ Some have argued that the depression served as "a place for the collection of skeletal remains,"⁴ and this suggestion seems to have some validity in the light of the discoveries at Ramat Rahel.⁵

George E. Mendenhall suggested that this square depression served as a sump and constituted an architectural parallel to tombs in the middle Euphrates region.⁶ Sediment deposits in several of the pits appeared to support this conclusion. However, there are some technical aspects of this theory that make it unconvincing. Dewey Beegle observed (of F.18 and other tombs) that the *loculi* sloped away from the center and gave evidence that pools had formed over the years in the center and back of these *loculi*.⁷ This same phenomenon was noted also in F.27 and F.31. For example, in F.27 the floor of *Loculus* 5 (numbered from left to right) at its entrance was 0.03 m. lower than the edge of the central pit; *Loculus* 6 had a similar 0.05 m. difference, and *Loculus* 7 an 0.08 m. difference. All of these produced a silting effect of considerable proportion within the *loculi*. This was true in F.31, with heavy silting in the entire front of the tomb and in most of the *loculi*. If the square depression in these Roman tombs was designed solely as a sump, then some of the tomb diggers had failed at their task.

The origin of this depression can be attributed to two possible typological histories. One is that it was a vestige of the earlier Iron II and Hellenistic tomb design, which included benches around a central depression. But this would not account for the common occurrence of such depressions in Roman tombs outside Palestine.⁸ Furthermore, the squares are often rather small and would require considerable grading for drainage from *loculi* to the pit.⁹

It is possible that the square depression is merely one of many architectural features which mirror Roman house design. The *atrium*,

² E. L. Sukenik, "The Earliest Records of Christianity," *AJA* 51 (1947): 351.

³ Robert H. Smith, "The Tomb of Jesus," *BA* 30 (1967): 87-88.

⁴ Jack Finegan, *The Archaeology of the New Testament* (Princeton, 1969), p. 185.

⁵ Eric M. Meyers, "Secondary Burials in Palestine," *BA* 33 (1970): 20.

⁶ Waterhouse, "Areas E and F," p. 115, n. 5.

⁷ Beegle, "Necropolis Area F," p. 207, n. 1.

⁸ As, e.g., in Hypogeum 33 at Dura-Europos. See J. M. C. Toynbee, *Death and Burial in the Roman World* (New York, 1971), p. 223.

⁹ Note the small depression in G.10. Stirling, "Areas E, F, and G.10," p. 104.

the central front room of the traditional Roman house, had an *impluvium* (a square or rectangular basin for rainwater) under a roof opening in the center of the room, as is well illustrated in the excavations at Herculaneum.¹⁰ Thus the square depression in the center of these tomb chambers may have been designed as a drainage area much like the *impluvium* in the Roman *atrium*, with the loculi serving as the adjacent "rooms" for its occupants. The fact that silting occurred outside the sump area may be due to ground shifting as a result of earthquake activity or to the tomb masons' merely following an old but ill understood architectural tradition.

That at least one mason recognized the function of the depression is clear from tomb F.28, which had two canals cut in the steps leading to the square depression. It is possible, therefore, that this Early Roman tomb architecture stemmed from domestic architecture.

It is also possible that the depression created benches as a work place for final preparations of a body before burial. Such a bench is hinted at in Mark 16:5 (cf. John 20:12).

Unlike most of the chamber-with-loculi tombs of the Early Roman period, Tomb F.27 displayed considerable architectural irregularity in the facades of the various loculi. Loculi 1 through 5 were fairly uniform with a recessed margin around the vertical face of the entrance. However, Loculus 6 had a facade which was flush with the piers and overhead, while Loculus 7 was cut flush with the ceiling and gave no evidence of recessed margins (see Pl. XI:B). It appeared that the various loculi were not cut by one man, nor all at the time of the original construction.

A study of the tool marks in the various loculi also pointed to workmanship of different masons, who used no less than four different tools and different digging techniques. Loculi 5 and 6, for example, were cut with the common wedged-shaped chisel which had a cutting edge measuring 0.009 m. wide. A blade with a serrated edge measuring 0.005 m. wide was employed in Loculi 5 and 1, but not apparently on the facades or the inside of other loculi. Loculus 7, however, saw the use of a tool with a larger blade, measuring 0.05 m.

The variation in tools and techniques and the differences in the facades of the loculi pointed to sequential construction of the tomb. That factor, combined with the unique appearance of trough burials in the southwest sector of the tomb, seemed to indicate that portions of the tomb were prepared upon demand.

¹⁰ Joseph J. Deiss, *Herculaneum: Italy's Buried Treasure* (New York, 1966), pp. 6, 15, 17, 31, and photos on pp. 16, 63. See also Toynbee, *Death and Burial*, pp. 23, 38.

In spite of both ancient and modern robbing, numerous funerary objects were found in the loculi and burial troughs and on the floor. On top of Locus 7, just inside the tomb entrance, was found a small dish containing a button, bone pin fragments, bone needles, and an ivory mirror handle. A candle placed in the center of the objects indicated that modern tomb robbers had collected these in the dish but for some reason had left them behind. The tomb produced the usual range of funerary materials including bronze and copper bracelets, spindle whorls, cosmetic spatulas, iron nails, and bone hairpins. A very attractive solid gold earring, found in Loculus 7, was one of the finest objects found at Tell Ḥesbân (see Pl. XII:A).

Bone analysis indicated approximately 17 burials, including at least four children. Among the adults the most common pathological condition was arthritis. Ceramic evidence indicated a Late Roman I-II origin for the tomb and stratigraphic analysis pointed to five phases of tomb history.

The first phase included the original construction and initial use of the tomb in the Late Roman I-II periods. Presumably the north and east loculi were cut at that time, although not simultaneously. Since Loculus 7 and the subchamber containing the trough burials were without lintels, it may be assumed that these were prepared at the same time (or at least by the same mason); perhaps in the second phase of use in the Late Roman III-IV periods. Locus 6, located immediately outside the original sealing stone, and Locus 9 on the floor of the tomb in the northeast corner, confirmed this early sequence. Most of the tomb interior was disturbed to the point that stratigraphic analysis was impossible, but there a considerable portion of the northeast corner was undisturbed, and it was here that the various phases of the tomb use were evident. Only Loculi 1 and 8 were originally sealed by stone slabs, as was common in many Roman tombs, especially where a cult of the dead was practiced.¹¹ The slab of Loculus 1 was found sealed between Loci 8a and 9a in the northeast sector, indicating that the original disturbance or robbery of the tomb had occurred at the end of the Late Roman period or in initial stages of the Early Byzantine period.

The tomb was in use throughout the Early Byzantine period, as established not only by ceramic evidence inside the tomb but also by a section against the entrance (Locus 6). This accorded well with other burial patterns found throughout Area F and pointed to considerable population density at Tell Ḥesbân for the period.

¹¹ Toynbee, *Death and Burial*, p. 223; also Sukenik, "Records of Christianity," p. 352.

The Late Byzantine period saw the fourth phase of the tomb's use, and it appeared from the lack of significant quantities of ceramic materials to have been a much less important phase.

The final aspect of the tomb's history would be its violation in Ayyūbid/Mamlūk and Modern times. Of the loci adjacent to the entrance, only Locus 5, which included the six rough blocking stones over the entrance, contained Ayyūbid/Mamlūk and Modern materials indicating that the remainder of the entrance and lower portion of the sealing stone had not been disturbed since the Late Byzantine period.

Since the tomb was rather thoroughly robbed, it was difficult to determine whether or not its distinctive architectural features represented ownership by a wealthy family at Ḥesbān, or merely the work of creative masons.

Tomb F.28 (Fig. 11)

In connection with the tomb exploration of the 1971 season, Philip Hammond and his University of Utah team conducted magnetometer and resistivity tests in a sector 10.00 x 30.00 m. running north-east to southwest, just to the west of Tomb F.5. While the magnetometer survey results were not especially useful, the resistivity chart did indicate several likely tomb locations. One of these proved fruitful with the discovery of F.28.

This tomb, of the square-chamber type, had twelve loculi and also three arcosolia cut immediately above the loculi in the north, east and south walls (see Pl. XII:B). The tomb was found sealed with the original blocking stone *in situ* and a considerable amount of heavy rubble immediately in front of the stone—a sign that the tomb had not been entered in modern times. A section cut against the blocking stone indicated that the tomb was in use from the Early Roman period into the Early Byzantine period but no later than the middle of the fourth century A.D. This range of use was confirmed by stratigraphic and ceramic indicators inside the tomb as well.

This tomb had two unique features. One was the presence of very small loculi on the north side. Loculi 3 and 4 were approximately one half the length of the other well cut loculi. The very rough tooling in the back ends of these indicated that they were never completed. The tomb had the usual square depression in the floor, into which led two channels cut on either side of the main step. This is one of the clearest indicators that the depression was designed for drainage purposes. If so, as noted earlier, however, engineering skill in this area was something less than precise in that the floor on either side of the channels

sloped away from them. The loculi surrounding the central chamber were generally square cut and at right angles to the chamber walls. The interior of the tomb had been completely filled as a result of the collapse of all but very small segments of the ceiling—an indication of earthquake activity of some proportion. The tomb, even though not robbed in modern times, appeared to have been disturbed in the Byzantine period. Very few significant objects were found either in the loculi or on the floor. A pin and glass vase were recovered from Loculus 2 and a few small metal fragments elsewhere. None of the loculi contained more than one burial. It appeared that the tomb had only sporadic use into the Early Byzantine period, when it was destroyed. The presence of three arcosolia cut above the loculi is unknown except at Tell Ḥesbân. Each of the arcosolia was furnished with a slightly raised lip at the front edge with a small drainage canal through it.

The tomb exhibited five phases of history. The construction of the tomb and its initial use can be clearly dated to the Early Roman IV period (A.D. 70-135). The tomb continued in rather limited use into the Late Roman I-II periods (A.D. 135-95) with a final phase in the Early Byzantine I-II periods (A.D. 324-65). The fourth phase of the tomb's history would be its destruction, probably in the great earthquake of A.D. 365. Ceramic materials in the entrance as well as the loci which constituted the original deposits within the tomb included nothing later than the Early Byzantine period. This appeared to confirm the end of the tomb's use.

The final phase of the tomb's history would be dated to the Early Byzantine III-IV and the Late Byzantine periods (A.D. 365-661). The destruction of the tomb by the earthquake left a considerable depression in the ground; and this was probably backfilled for agricultural use shortly after the earthquake, as evidenced by loosely packed yellowish red soil mixed with quantities of field stones and pieces of limestone in Loci 18 and 20.

At least two tools were used in the preparation of the tomb. The standard 0.009 m. wedge blade was the most common for finishing work inside the loculi. Loculus 3 gave evidence of a different tool—a wedge-shaped, flat bladed chisel measuring 0.0351 m. at its tip. This was apparently employed for the work in Loculus 3 alone, for no other evidence of it appeared elsewhere in the tomb unless it was the ceiling, which could not be examined.

The loculi and other architectural features of the tomb represented average workmanship. There was no painting or decoration, nor were there any sealing slabs for the loculi.

Tomb F.30

This vertical-shaft tomb was discovered a short distance northeast of F.30 and adjacent to a freestanding stone fence. The tomb must have been sealed by horizontally laid blocking stones which were set on the ground surface, for there was no evidence of a ledge inside the shaft, as was common to tombs of this type found elsewhere in Area F.¹² The arcosolia on either side of the shaft were typical of those common to the Byzantine period at Tell Ḥesbân. Each of the arcosolia, however, had been expanded into roughly square chambers with the ceiling sloping down at the back of each. The abundant quantities of Early Byzantine sherds in both arcosolia was clear evidence of their original use. Locus 3, which included the interior deposits of both arcosolia, contained not only Byzantine materials but Ayyūbid/Mamlūk as well. The north arcosolium was almost free of objects, while the south arcosolium contained significant quantities of human and animal bone along with numerous objects.

The south arcosolium had been entered in modern times from an adjacent cave. No objects of modern date were found in the north arcosolium or the shaft itself. This indicated that the tomb was in use in the Byzantine period and may have been expanded in the Ayyūbid/Mamlūk phase and even used for burials at that time. The tomb was filled in the Ayyūbid/Mamlūk period and not reentered from the shaft. The only portion of the tomb disturbed in modern times was the south arcosolium, which had been entered from the cave. Several objects of recent times were found in that arcosolium.

Bone analysis (based on the patellas) indicated that a minimum of 18 individuals had been buried in the tomb. Two of them infants and one possibly prenatal, four children ranging from five to ten years in age. Among the objects found in the south arcosolium were bracelets, earrings, a shell pendant, glass beads, iron rings, and a bronze fishhook. There were non-human bones—17 sheep, 3 chicken, and 1 dog.

Three phases of the tomb's history can therefore be distinguished: (1) the construction in the Early Byzantine periods (4th-5th century A.D.); (2) reuse and possibly expansion in the Ayyūbid/Mamlūk period, during which some robbery may have taken place; (3) the modern break-in from the cave to the southwest.

¹² Beegle, "Necropolis Area F," p. 203 and Plate 10:B.

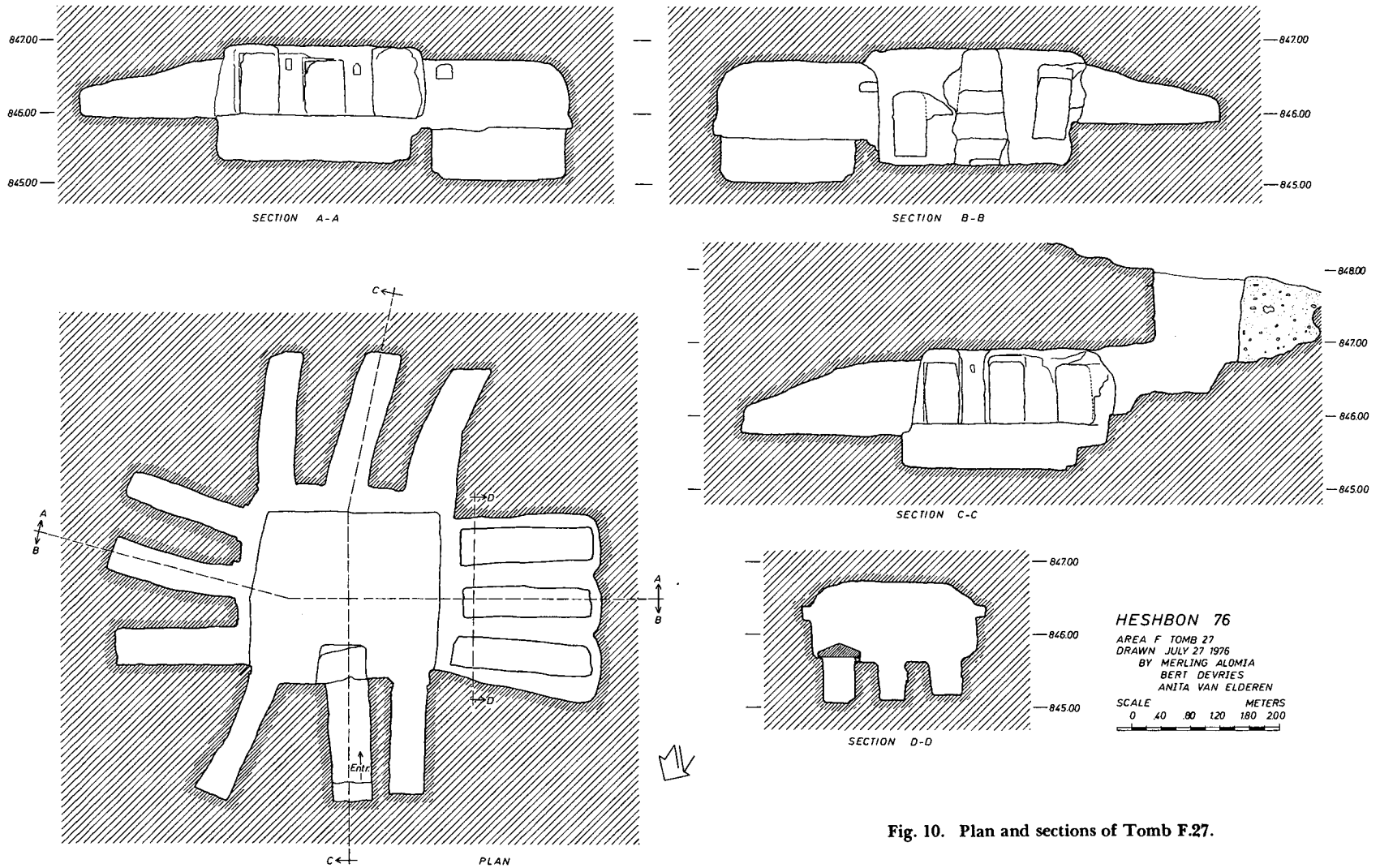
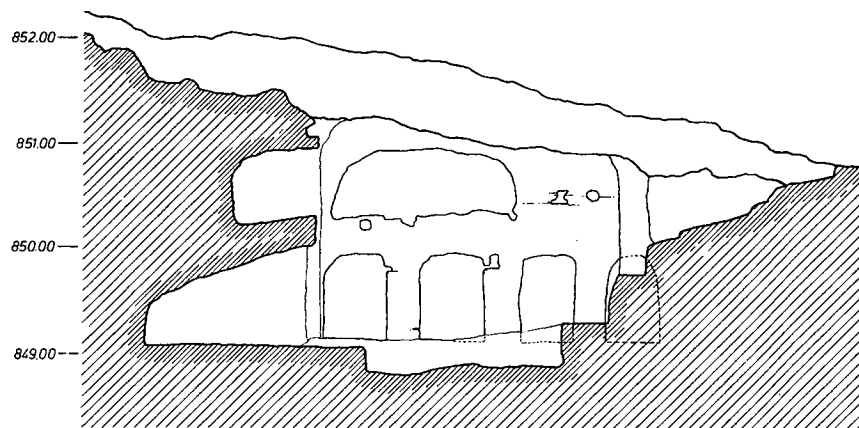
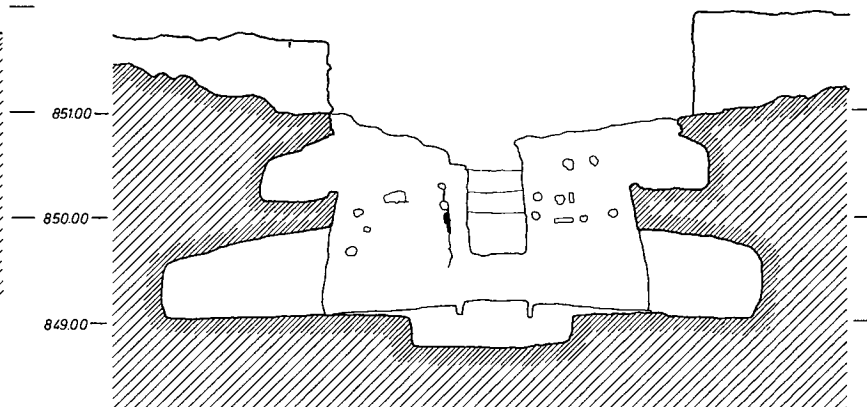

Fig. 10. Plan and sections of Tomb F.27.



SECTION A-A



SECTION B-B

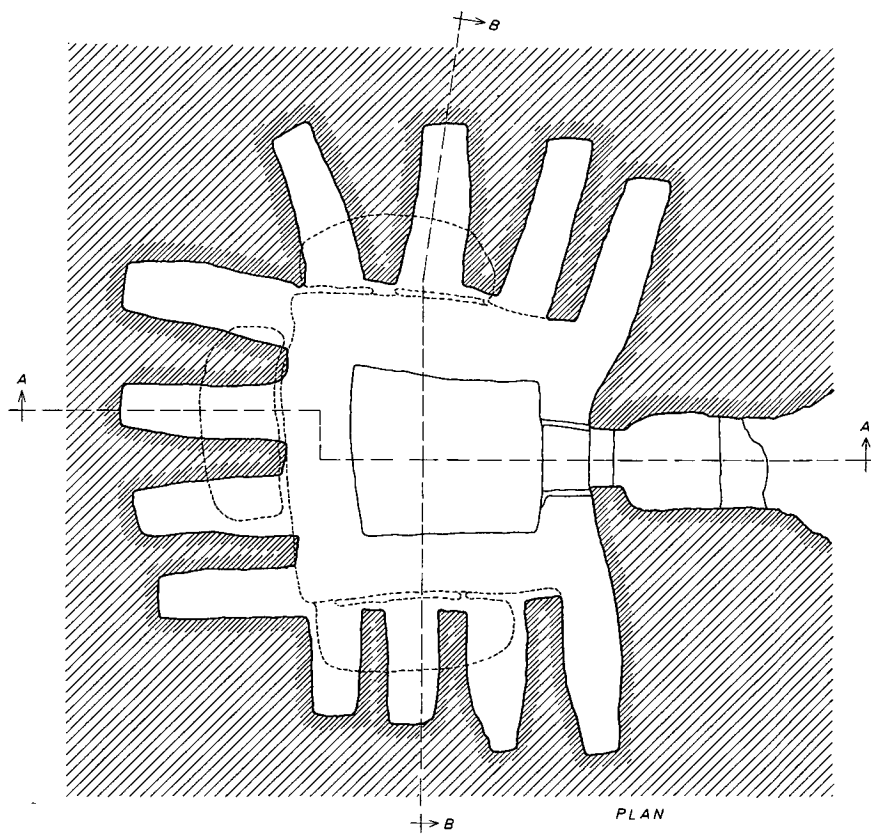

PLAN

HESBON 76

AREA F TOMB 28
 DRAWN JULY 28 1976
 BY MERLING ALOMIA
 DAVE PIPER
 ANITA VAN ELDEREN

SCALE 0 40 80 120 160 200 METERS

Fig. 11. Plan and sections of Tomb F.28.

Tomb F.31 (Fig. 12)

This chamber tomb, adjacent to and immediately south of F.28, had fourteen loculi—one on either side of the entrance and four on each of the remaining chamber walls. It was characterized by outstanding craftsmanship and design (see Fig. 12). On the floor of the main chamber was the characteristic square depression, which was not as large as in other tombs of this type (see Pl. XIII:A). The loculi are well cut and very symmetrical, extending at true right angles from each of the chamber walls. Unlike those in F.28, the loculi were very neatly arched at the top and all were approximately the same in dimensions. (This was not the case in F.27 and F.28.) Only one lamp niche appeared in Tomb F.31, situated in the chamber wall above Loculi 7 and 8. It was triangular, comparable to the one in Tomb G.10.¹³

The exterior of the entrance to the tomb was arched and cut in the same manner as the loculi. Two steps led down to the main chamber. Immediately above the top step was a concave cut that further exemplified the special craftsmanship employed in this tomb.

The entrance was sealed by a large cut stone slab. Three distinct loci could be identified immediately in front of the sealing stone. The topmost layer, 0.24 m. deep, consisted of loosely packed dark reddish brown soil with some lime chips. Locus 5, immediately below, consisted mainly of rock fill, of light reddish brown soil loosely packed with some lime chips. The rocks varied in size from 0.08 m. to 0.35 m. in diameter. Locus 6, immediately below Locus 5, consisted of reddish brown soil packed rather hard, with some evidence of lime flakes. This layer was 0.38 m. in depth. Pottery from these three loci indicated that the tomb was in use over a considerable period of time, concluding with the earthquake of A.D. 365. An Ayyūbid/Mamlūk sherd in Locus 5 was regarded as probably intrusional. The stratigraphy of the section against the exterior of the sealing stone agrees completely with stratigraphic analysis within the tomb itself.

Eight distinct layers of deposit were distinguished in the floor of the main chamber, including the square depression (see Pl. XIII:B).

The tomb was discovered entirely filled with soil and rubble from a complete ceiling collapse, probably attributable to the earthquake of A.D. 365. The topmost layer in the tomb consisted of a loosely packed reddish brown soil with a considerable number of lime chips. This locus covered the entire interior of the tomb's main chamber and rested immediately above Locus 13, which consisted largely of

¹³ Stirling, "Areas E, F, and G.10," p. 104 (section A-B).

fractured limestone and rubble from the ceiling collapse. Limestone fragments in Locus 13 varied in size from small chips to larger pieces measuring 0.60 m. long, 0.40 m. wide, and 0.30 m. thick. The average depth of this locus was 2.50 m. and it covered the entire chamber with some intrusions into the loculi.

Ceramic materials from these loci and others on the floor of the tomb, as well as in the loculi, gave a clear picture of five distinct phases of history. The initial phase was its construction and first use in the Early Roman II-III periods, as determined from its architectural features and from sherds found in silt layers on the floor and in the square depression. Ceramic evidence for this period was also found in Loculi 1, 7, 13 and 14.

Locus 1 turned out to be the most significant of the fourteen in the tomb. Like most of the loculi in the tomb, it was partially filled at the entrance with fractured ceiling material. This material sloped down to about midway back into the locus. Mixed with fractured ceiling material was a loosely packed reddish brown soil with some lime chips.

The locus contained the burials of at least ten individuals, based on a count of left patellas: one infant of about one year or less, one youth about ten, another under 15, one adult about 30 or 40 with moderate lipping of vertebrae (indicating the early stages of an arthritic condition), one adult over 65 with severe vertebral lipping, and several adults, of indeterminable age. Adult height ranged from five feet to five feet six inches. Also of special note were two individuals with septal apertures in the distal end of the humerus, perhaps merely a female—or possibly a family—characteristic. With this feature present in only two humeri, it would be somewhat risky to reach a conclusion.

Locus 1 enjoyed a very long use. Pottery from the Early Roman, Late Roman and Early Byzantine periods was present. Since no nails were found, presumably wooden coffins were not used. The large pile of bones pushed to the back would indicate that the latest burial was placed in the front and middle of the locus. Resting on top of the bone material midway back in the locus was a large cooking pot, clearly of the Early Roman type, such as have been found recently in the Jerusalem excavations,¹⁴ but with the distinction of having four handles instead of the usual two. Inside the pot were the ashes of a human cremation.

¹⁴ Nachman Avigad, "How the Wealthy Lived in Herodian Jerusalem," *BAR* 2 (1976): 28.

Cremation was common during most of the Republican period in Rome, but in the second century inhumation began to gain in popularity. The cause of the change has been debated. Some attribute it to rising Christian influence, others to the influences of the mystery religions. In Greece and the Near East under the Empire ". . . burial and cremation had from old existed side by side."¹⁵ This observation seemed to be supported by the evidence of Loculus 1. Assuming that this cooking pot was the original container for the ashes, it would be possible to date the cremation approximately. Presumably some of the other disarticulated bone materials would also be datable to the Early Roman period.

According to Roman custom the corpse, and sometimes the couch on which it lay, would be burned either at the burial place or at a place especially reserved for cremations. The various types of urns for the ashes were made, according to the wealth and prestige of the individual involved, of marble, alabaster, gold, silver, lead, and glass, and sometimes were earthenware pots.¹⁶ Cremation was often practiced during the Republic in order to prevent mutilation of the corpses during the civil wars, although at Heshbân it may have been merely the perpetuation of a funerary rite or a matter of practical necessity.

In addition to the cooking pot, Loculus 1 contained glass vases, a fragmented alabaster bowl, several ivory pieces (including an applicator), ring fragment, pins, and buttons. Just inside the entrance and to the right of the loculus, was a small Early Roman juglet with a strainer and spout, unique because of the Nabataean-type painting on the outside. It might be related to similarly painted pottery found recently in Jerusalem.¹⁷ Several bronze bracelets, a Herodian lamp, and rings were also located among the disarticulated bone materials. Perhaps the most interesting was an Egyptian scarab, which was apparently a family heirloom (see Pl. XIV:A; XIX:A).

Burials were found in all the other loculi, the number in each varying from one to three, generally, with as many as seven in Loculus 8. Evidences of cremation were also found in Loculi 2 and 8, but no urns or pots. It is possible, of course, that pots like the one found in Loculus 1 had been present, removed later and the contents dumped.

Bone analysis indicated that no fewer than 35 individuals had been

¹⁵ Arthur D. Nock, "Cremation and Burial in the Roman Empire," *HTR* 25 (1932): 321, 327.

¹⁶ Toynbee, *Death and Burial*, pp. 49-50.

¹⁷ Avigad, "Herodian Jerusalem," p. 28.

buried in the tomb. If there had been other burials outside the loculi, the bones were too scattered and fragmented to present a clear picture.

Pathological features of the bone materials included arthritic conditions (frequent), abscesses in several of the teeth. Evidence also of considerable surface wear, on a number of the adult teeth, was probably attributable to grit material in the flour they had used.

Especially important for dating were three unbroken Herodian lamps immediately below the lamp niche on the east side of the main chamber. Probably all three lamps were jarred from the niche during the A.D. 365 earthquake and remained embedded in the Locus 13 ceiling debris until the excavation of the tomb.

Also significant was the absence of animal bones and, in particular, the bones of pigs. Traditional Roman funerary practices required that "only when a pig had been sacrificed was a grave legally a grave," and sometimes even pet animals were killed to accompany the soul into the after life.¹⁸ The lack of animal bones and *triclinia*, the continual use of the tomb, the absence of painting and carved sealing stones for the loculi, all indicated that there was not a particularly active tomb cult at Tell Hēsbân in the Roman period. Burial practices, especially those related to inhumation, were as much influenced by their Semitic surroundings as the well defined traditions at Rome.

An analysis of tooling techniques in F.31 indicated that all the work was done by one mason, utilizing only two basic wedge-shaped tools. The standard .009 m. chisel was in evidence throughout, also a flat-edged chisel that measured 0.01 m. at its most narrow point. The width and angle of the cutting strokes using these instruments in all the loculi were consistent. All loculi were rounded at the top in the front with cutting strokes angled down and inward. Half way back through the loculi the corners were squared and the ceiling was flattened out.

Architectural and ceramic evidence indicated that F.31 had a history that can be related to six distinct periods of time.

1. Its construction and first phase was attributed to the Early Roman II-III periods because of the very heavy concentration of Early Roman II-III sherds, though a few Late Roman pieces were found also in Locus 31. This locus, a light gray-brown, tightly packed silt deposit, with very few small lime chips, covered the entire bottom of the square depression in the floor. It was directly above Locus 32,

¹⁸ Toynbee, *Death and Burial*, p. 50.

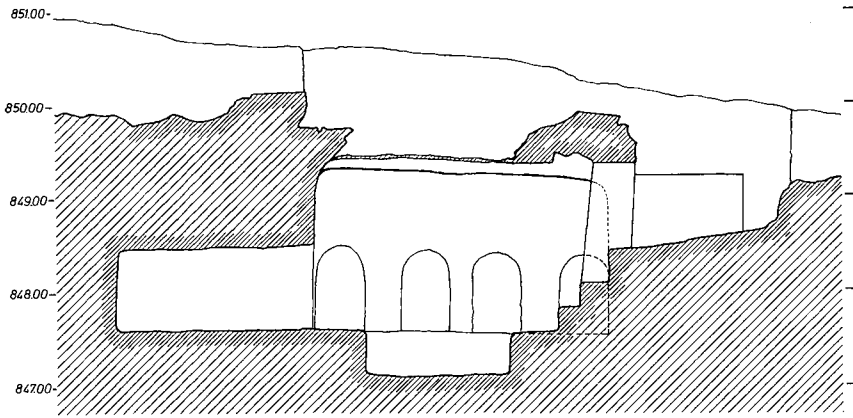

SECTION A-A

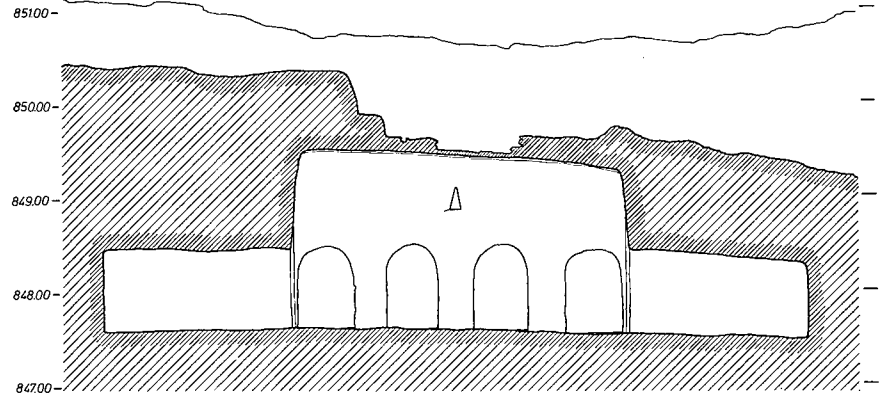

SECTION B-B

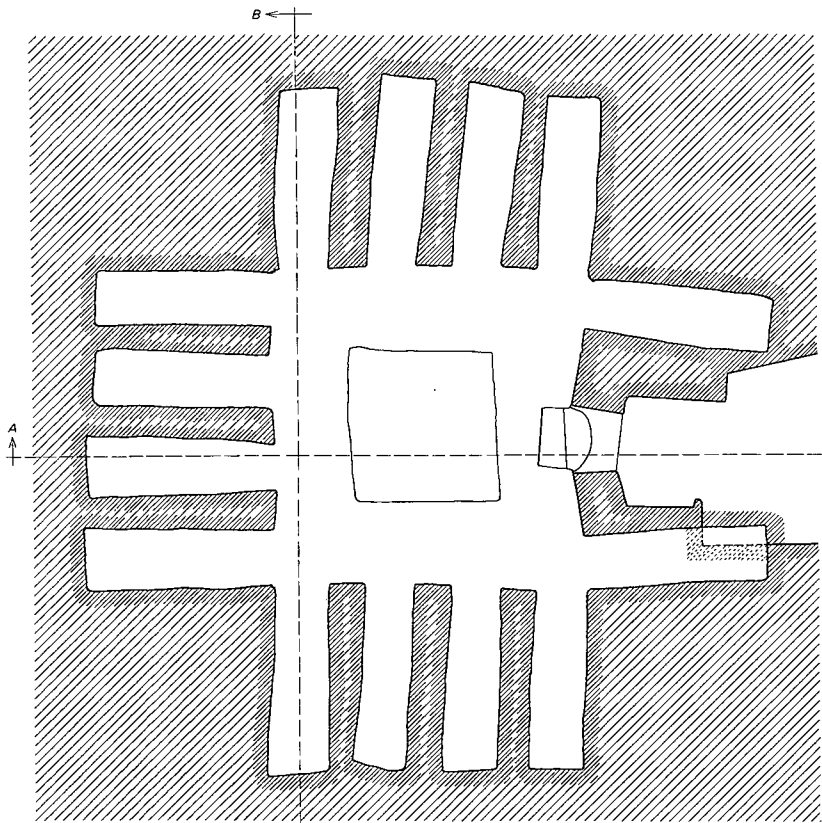

PLAN

HESBON 76

AREA F TOMB 31
 DRAWN AUGUST 7 1976
 BY MERLING ALOMIA
 DAVE PIPER
 ANITA VAN ELDEREN

SCALE 0 40 80 120 160 200 METERS

Fig. 12. Plan and sections of Tomb F.31.

of the same extent, a very fine, tightly packed, light tan silt layer averaging 0.02 m. deep and containing no sherds or bones. The evidence pointed to the construction of the tomb about A.D. 70.

2. Tomb 31 also saw some use in the Early Roman IV period. Ceramic materials for this were also located in Locus 31 as well as Loculi 1 and 7.

3. Use continued throughout the Late Roman I-III periods, abundant evidence for this phase existing immediately adjacent to the sealing stone outside the tomb (Loci 4, 5, 6), as well as inside (Loci 30 and 31).

4 and 5. The tomb's heaviest use was in these phases. Evidences for the Late Roman III-IV usage were found in Loculi 1-7, 13 and 14, as well as in layers on the floor of the tomb and outside the entrance; and for the Early Byzantine I and II periods in every loculus with the exception of 14. Period 5 ended with the tomb's destruction, along with Tomb F.28, in the earthquake of A.D. 365. With only one exception, no pottery appeared inside Tomb F.31 which was later than this date—a single piece of Early Byzantine III-IV pottery, apparently intrusive, was found in Locus 13, an upper section of rubble fill that came down with the ceiling.

6. The final phase was the filling operation, probably in the Early Byzantine III-IV periods. Presumably, as in the case of F.28, a sizable depression was left in the ground that was unsuitable for agriculture. The great abundance of rock-carved vats and presses in the surrounding region with deposits attributable to this period seemed to indicate considerable agricultural activity.¹⁹ Such activity probably continued with considerable intensity throughout the Ayyūbid/Mamlūk and Modern periods, judging from the ceramic materials near the ground surface.

Cave F.34

In an effort to learn more about burial patterns associated with the Tell Ḥesbân occupational history (especially the Iron Age), exploration of four caves was undertaken. For the first time access was permitted to the caves in a privately owned orchard immediately below and west of Area C.

F.34, on the lower west slope of Tell Ḥesbân, was a rather large cave with some ceiling alteration in the form of arching at the back. A one-meter-wide probe trench was sunk in the cave on a line perpen-

¹⁹ See Waterhouse, "Areas E and F," p. 113.

dicular to the entrance face, and the same procedure was followed outside the entrance, in order to get an accurate stratigraphic profile of the cave's history. It appeared that the cave was used largely for domestic purposes, its earliest use in the Late Roman period evidenced by concentrations of sherds in Locus 4d, a layer immediately above bedrock. The cave was extensively used in the Early Byzantine III-IV periods, during which time a large circular cut was made in the bedrock. The southwest sector of the trench exposed only a portion of this circular cut.

The third phase of the cave's history, in the Late Byzantine period, yielded significant ceramic materials; a number of "wasters" indicated that pottery making was carried on at Tell Ḥesbân, probably in the immediate region.

The cave saw very heavy use in the Ayyūbid/Mamlūk period. Objects from this phase included a partially broken lamp, an iron ring, and glass fragments. The bones of sheep and goats were also evident.

In modern times the cave has been used largely as an animal pen or as an occasional shelter.

Cave F.37

This large cave, located west of Tell Ḥesbân on the floor of Wadi el-Majarr, attracted attention because of noticeable plaster work on several portions of the ceiling, also several curves cut in the outer edges of the ceiling. In order to get a stratigraphic profile of the cave's interior, a 1.00 m. wide probe trench was laid at right angles to the entrance face and was continued 6.00 m. long to the back of the cave.

Suspicious about the use of the cave for burials were confirmed when two complete sarcophagi were uncovered, both intact but lidless and filled with soil. The first sarcophagus encountered was oriented north and south and ran directly across what had been assumed to be the cave entrance. Apparently the more ancient entrance was farther north. The two sarcophagi, which were butted against each other at right angles, were both very finely cut with a rounded outer contour between lip and base but no inscription or bas-relief decoration. A total of 34 bone fragments were removed from the sarcophagi and from immediately outside them in the corner at which the two met. In addition to a few cremated fragments, there were evidences of two human fetuses, one six-month-old infant and one child about a year old.

This cave was especially interesting because further excavation revealed three more stone-cut sarcophagi—all five of them being arranged in a rectangular pattern around a *balat* floor that was very well cut, its blocks fitted with amazing precision. The three other sarcophagi had been not only robbed but apparently broken during times when the cave was used for domestic purposes. Sarcophagus 3 (counting from right to left) had a *ṭabun* in its northeast corner.

The use of this cave for burial purposes was interesting since it was far removed from the tell and not easily accessible.

The earliest use of the cave was traced to the Early Roman IV period but evidence for construction is later. It was during its second phase of use that the *balat* floor was laid and the sarcophagi were put in place. The construction of this burial site appeared to have been completed near the end of the Early Roman IV period. The stratigraphic profile against the two sarcophagi in the southwest corner indicated that the burials were first disturbed in the Early Byzantine period; the sarcophagi were probably robbed then and the bones scattered on the floor. Yet the use of the cave as a burial ground continued. In the west side of the cave, a disarticulated Late Byzantine burial with a lamp was discovered.

Bone analysis indicated that no fewer than 49 individuals were buried in the cave: 33 of them were fetuses, three newborn to six-months old, and four approximately one year old. Nine of them were adults. Fetus materials were found in abundance in the second through fourth phases of use (Late Roman III to Late Byzantine). Clearly the cave had a unique burial tradition which accounted for the large, well cut sarcophagi and a *balat* floor in such a remote setting.

The cave ceased to be used for burial purposes during the Umayyad period (the fifth phase), and domestic use was rather limited. In the final phase, the Ayyūbid/Mamlūk period, the cave was the scene of maximum domestic activity. To this phase belongs the small *ṭabun* constructed at the north end of sarcophagus 3. In modern times the cave was used as a temporary shelter or an animal pen.

Cave F.38

Smaller than F.37 but equally important as a burial site, was Cave F.38, located a short distance north of F.28. It was selected for a probe because it had features on the walls and ceiling that were like those noted in F.37. At its widest points, the cave measured 7.50 x 5.25 m. Two probe trenches were dug inside the cave. The first, measuring 1.50 x 2.00 m., was dug at right angles to the entrance;

the second was dug from the east end of the main trench south to the wall.

The earliest attested use of the cave, attributable to the Early Roman III-IV period, appears to have been largely for domestic purposes; and if for burials, only to a limited extent. In its succeeding three phases, Late Roman I through Early Byzantine II, the cave was used frequently for burials. In the two probes undertaken, portions of 40 individuals were recovered, ranging from a fetus to an adult 70-80 years old. The bones of common domestic animals (sheep, goats, and donkeys) were very much in evidence.

Late Roman ceramic materials indicated the heaviest use of the cave for burials in that period. Objects from this period included bone hair pins, needles, bronze rings, beads, and bracelets. It was clear that although most of the bones were disarticulated because of grave digging for subsequent burials, there was no robbery of the cave. Furthermore, the presence of at least two articulated burials was evidence that this was not a repository for secondary interment.

Bone analysis indicated pathological problems similar to those encountered in other tombs of the period. Arthritis, tooth wear, and dental decay were quite common. One skull, that of a twelve-year old, had a hole in the top, indicating either a tumor which ate out the bone or a hole drilled for the purpose of alleviating pressure. In spite of continuous burial activity over a long period of time, relatively few of the bowls, dishes, and lamps were broken. There was no evidence that the bodies had been oriented in any particular direction, although the two articulated skeletons were oriented east-west.

The cave continued to be used for burials during the Early Byzantine I-II periods. A well preserved ring with a small cross probably belonged to this phase.

It was clear, therefore, that two distinct types of burial patterns were practiced at Tell Hesbân throughout the Late Roman and Early Byzantine periods. For the more wealthy or perhaps politically important people there were the rock-cut tombs. But for those of low social or economic standing the caves served as the final resting place. Possibly caves such as this were used to bury persons who died under special circumstances or who had no local relatives. There was no evidence that coffins were used in the cave burials. Presumably the bodies were wrapped in linen shrouds and buried in a fully extended position. The funerary objects were comparable to those placed in the tombs.

The final phases of Cave F.38's occupation were traced to the

Ayyūbid/Mamlūk period, when it was utilized solely for domestic purposes. During this time, while the south end of the cave was altered or expanded, the occupants of the cave apparently attempted to cut a large bench and in the process cut into the back end of a loculus which extended from a standard Early Roman tomb located to the south. It was probably then that the tomb was plundered. A small brooch, beads, and a well-cut crystal piece were discovered from this period. The crystal may have been used as part of an earring or bracelet, or worn on a necklace.

The cave was used also in the Modern period exclusively as a temporary shelter. The cave's burial history, therefore, was parallel to that of the cemetery history in Area F.

Tomb F.40

The single-chamber Tomb F.40 was discovered to the west of Cave F.38 with a square-cut entrance comparable to other Roman tomb entrances in Area F. Access to the main chamber was gained by two small steps in the entrance and one large step inside the chamber itself. The entrance was found filled with soil and blocked by one large uncut rock on the outside, in front of which were larger field stones, perhaps part of the original deposit. Ceramic evidence immediately outside and inside the entrance indicated that the tomb had been opened in the Ayyūbid/Mamlūk period and probably emptied of all funerary objects. The general lack of ceramic materials both inside and outside the tomb indicated that it had very limited burial use.

The single chamber beyond the entrance did not have the customary loculi or the square depression in the floor. There was evidence for only one or two adult burials, with no funerary objects. Ceramic evidence on the floor indicated that the tomb was prepared at the end of the Late Roman or the beginning of the Early Byzantine period, and the burials then made. The tomb was not reopened again until the Ayyūbid/Mamlūk period.

If the tomb was completed, it represented a rather unusual architectural type for this period. It is possible, however that it was never completed. Unlike other tombs in the region it did not suffer from earthquake activity. There were several small cracks and fault lines inside the tomb as a result of earthquake activity, but no ceiling collapse as was noted in F.28 or F.31. The chamber itself was considerably smaller than those of the Early Roman tombs discussed above. It measured 3.18 m. at its widest point, and was 3.82 m. long.

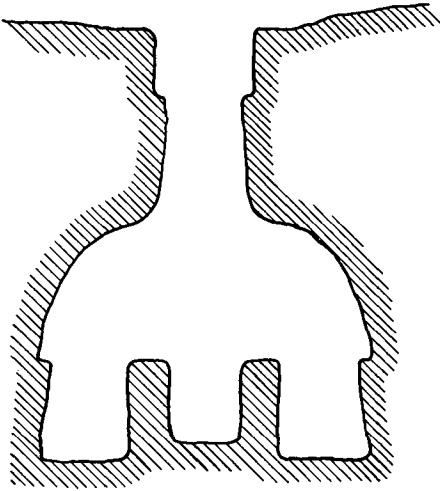

SECTION A-A

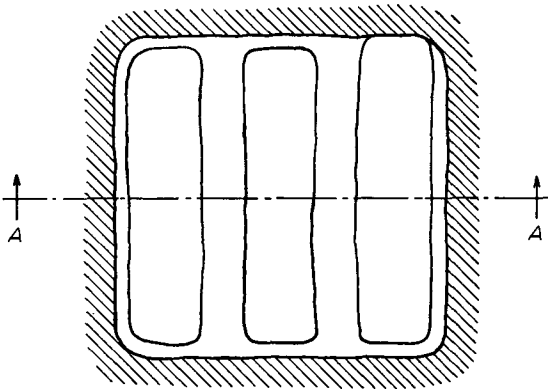

PLAN

HESHBON 1976

AREA K1 TOMB

DRAWN 5 AUGUST 1976

BY HENRY KUHLMAN

SCALE METERS

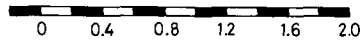

Fig. 13. Plan and section of Tomb K.I.

Cave F.41

A large cave located northeast of Tell Ḥesbân had several small arched chambers cut into the back of its ceiling, not unlike those of F.37 and F.38. A 1.00 m. wide probe trench, cut at right angles to the entrance face and continued to the rear of the cave, produced no evidence of burial activity. The cave was apparently utilized only for limited domestic purposes as a shelter in the Iron Age II period and through the Early Roman, Early Byzantine, and Ayyūbid/Mamlūk periods. The lack of domestic ware indicated that it served more as a temporary shelter or animal pen than for extended human occupation.

Tomb K.1 (Fig. 13)

In previous seasons, tomb exploration was concentrated largely to the west and southwest of Tell Ḥesbân. A rather large cemetery was also located directly east of Tell Ḥesbân, with evidence of many shaft-type tombs first noted by walk-over in 1968. After several small probes, K.1 was located. It was a vertical-shaft Late Roman or Early Byzantine tomb, with the usual interior horizontal ledge on which square-cut stones were placed in order to seal the shaft (see Fig. 13). Four of the square-cut sealing slabs were found *in situ*. The east end of the shaft had been filled with large rocks, however, indicating that the tomb had been violated.

The shaft was widened at the bottom, forming an arcosolium on either side, and had three parallel troughs, oriented east-west, cut into the floor. Each of the arcosolia had a horizontal trough, and a smaller central one was cut between the two. The contents of the tomb had been disturbed, probably in the Ayyūbid/Mamlūk period, as indicated by Ayyūbid/Mamlūk sherds and a Mamlūk coin (Object 2879). Bone fragments indicated the burial of only one adult. Either other bone materials had decayed or they were removed during the robbery of the tomb. It was sealed and not reopened until expedition activity in 1976. The only objects from the tomb, in addition to the coin, were two parts of a glass bracelet.

Tomb K.2

Another similar shaft-type tomb, located just north of K.1, was opened for preliminary study and evaluation, but time did not permit complete excavation. The shaft entrance was similar to that of K.1. Three of the square-cut limestone sealing stones were intact, but all

were in badly deteriorated condition. The shaft above the ledge was filled with heavy rubble.

Brief exploration inside brought to light a very well preserved bronze anthropomorphic bottle, probably used for cosmetic purposes. It had two rings which represented ears, originally attached to a chain to be worn around the neck. The stylized female form was characteristic of types from the Byzantine period.

A brief survey of Cemetery K indicated that this sector was extensively used in the Byzantine period and to a lesser extent during Roman times. The southwest slope of this hill contained an abundance of robbed-out shaft-type tombs. Several chamber-with-loculi tombs were located on the western slopes.

Conclusion

Four seasons of tomb exploration at Tell Ḥesbân have given evidence of sizable populations from the Early Roman period through the Ayyūbid/Mamlūk periods. Burial patterns and customs were best attested for the Early Roman, Late Roman and Early Byzantine periods. That there was an Iron Age settlement at Tell Ḥesbân is clear from the mound itself, but burials from the Iron Age period continued to elude the excavators in spite of concentrated efforts to locate them.

Four seasons of tomb exploration have demonstrated that burial patterns were quite varied and were practiced in a wide variety of locales. Hills to the northwest and west of Tell Ḥesbân were used throughout the Roman period for burials, and Area F, the largest cemetery, contained a wide range of burial types beginning with the Early Roman through Late Byzantine periods.

AREA G.4, 13, 15

DONALD H. WIMMER

Seton Hall University
South Orange, New Jersey

Squares G.4, 13, and 15 (forming a triangle with sides of 40, 78, and 110 m.), lay southwest of the acropolis on the terraces west of the plateau of the caravanserai, near Benchmark A (872.62 m. above sea level).

As the accompanying terrain map shows (see Fig. 14), other natural and architectural features surround these Squares—caves, cisterns, field walls, an arch, and other architectural remnants. Some of the natural caves¹ had been deliberately refined for some useful purpose. All caves (one hewn into three shapely rooms) contained evidence of most recent use for animal shelter.

Since any cave could be cleaned periodically, significant stratigraphy would not be available from inside. Hence excavation of the soil layers immediately outside one cave entrance (G.4:1) was one of the goals at the beginning of the 1976 season. But it had to be abandoned in favor of the goal to reconstruct the usage history of the cave interior and of the adjoining cistern complex, in other words, to complete and confirm the sketchy report given in the Heshbon 1973 report.²

CISTERN/CAVE COMPLEX G.4

The 1973 preliminary exploration of the cave followed upon a villager's report of numerous tunnels leading from it.³ Entrance

¹ Formed by the erosion of varied limestone formations of the area, near the edge of the Transjordan plateau. See Reuben Bullard, "Geological Study of the Heshbon Area," *AUSS* 10 (1972): 129.

² Excavating beneath G.4:1 to bedrock was impracticable for reasons of safety and because the removal of the substantial amount of very late material would have precluded all work within the cistern complex itself.

³ On the 1973 report, see Dewey M. Beegle, "Soundings—Area G," *AUSS* 13 (1975): 215. The 1976 season confirmed what is reported there. What is called *Qasr* there is called the *Caravanserai* in the accompanying terrain map. (The

G.4:1, ca. 1 m. wide x 2 m. high, was blocked with field stones sealing Cave G.4:2, which contained an open space ca. 8.50 m. x 4.00 m. and 2.00 m. high, divided into two pens by a modern low wall (G.4:3). Two tunnels, filled with silt up to 0.50 m. from the top, led from either end of the cave (see Fig. 15) to two other caves already accessible from natural mouths. The third tunnel (G.4:4) was almost totally blocked by the medium to large-sized field stones of Wall G.4:3, which led from the back of the cave 2.00 m. south, cutting into the northwest corner of large Cistern G.4:5, which led southwest to Intersection G.4:6 uniting with three more cisterns, G.4:7-9.

Stratum I/Post II Gap: Modern/Ottoman (ca. A.D. 1456-1976)

Stratum I, Modern, stood as a link between the current ethnographic studies being undertaken in the village of Ḥesbân, and the stratigraphy of older occupation.

Description (Stratification): A thin layer of soil covered the 0.75 x 0.15 m. threshold of cave Entrance G.4:1 at a level of 866.22 m. Inside Cave G.4:2, trenches were laid out in the west pen. A relatively level top layer (G.4:10) was a mixture of light brown soil, straw, and dried dung with some stones, lying on Floor G.4:11a, which slanted down to the floor of Tunnel G.4:4. Cistern G.4:5 had a top soil layer (G.4:22) of similar material with a greater percentage of stones but very little straw.

Description (Architecture): Three steps led down from the threshold of G.4:1 to cave Floor G.4:11a. Modern Low Wall G.4:3 was built ca. 1.00 m. wide over the steps and extended to Tunnel G.4:4, where it widened enough to prevent access to this tunnel.

Description (Bones): The Ottoman/Modern loci produced the following bones: 19 sheep/goat, 7 chicken, 2 horse, 1 large mammal, 1 turtle, 4 cow, 3 undistinguishable.

Description (Artifacts): The latest pottery from G.4:10, in the cave, was Modern/Ottoman and probable Ottoman; from Locus G.4:22 in Cistern G.4:5 was Ayyūbid/Mamlūk. Modern nails were driven into the walls of G.4:5, and relatively modern artifacts were found in Tunnel G.4:4 (some were registered because of their relevance to the ethnographic studies in the village). An Ayyūbid coin (object 2787, A.D. 1196-1218) came from Locus G.4:22. The following registered artifacts came from Modern/Ottoman loci:

writer's participation in the Heshbon 1973 expedition was funded, in part, by an award from the Seton Hall University Research Council.)

2229	Large Key	2233	Turkish Clay Pipe
2228	Stirrup	2222	Bronze Bracelet
2221	Flint (worked)	2223	Iron Hook
2231	Small Iron Horseshoe	2230	Plastic Comb
2232	Machine Part (iron)	2731	Loom Weight

Interpretation: Cave G.4:2 was used in Modern times for storing straw and firewood, and as a shelter for animals, particularly sheep and goats.⁴ A modern date for the sealing of Tunnel G.4:4 was attested in Wall G.4:3 by the presence of old shoes, tin cans, bits of old clothing, etc., near the top. Cistern G.4:5 showed Modern nails driven in the walls, but no Modern garbage, as was found in G.4:10 and 4. The scant Ottoman evidence mixed with modern remnants was found only in the cave.

Strata II-IV: Ayyūbid/Mamlūk (A.D. 1200-1456)

Description (Stratification): The top occupation layer of these strata, no longer separable from later Stratum I, rested on Floor G.4:11a, which was constructed during this period. Stratigraphy in Cave G.4:2 was based upon two trenches ca. 1.00 m. wide. One trench, running northwest to southeast, lay on the path between cave Entrance G.4:1 and Tunnel G.4:4; the other, northeast to southwest, ran parallel with the northwest wall of G.4:2 in the direction of the western tunnel. In the latter trench, Layers G.4:11b, 13, 15-18, and 20 (light brown, crumbly, with small stones and *huwwar* chips) lay under the ceiling collapse of G.4:11a. None was an occupation layer, though some signs of regular use were associated with Firepit G.4:19 near the cave wall just above the bottom soil layer (G.4:20).

In the trench leading from cave Entrance G.4:1 to Tunnel G.4:4 the filling was less distinguishable: gravel fill nearest the entrance and closest to bedrock, and dark, hard-packed, claylike soil at the entrance to Tunnel G.4:4, lying under a layer of firmly packed *huwwar* chips left from the carving of Tunnel G.4:4.

Excavation was pursued along the western half of Cistern G.4:5 into the middle of Intersection G.4:6, then was moved to the east from there on, in order to obtain better results from Cistern G.4:8, and to create a single straight central balk line running the entire length of the installation.⁵

Various soil loci continued over the plaster floor, through Cistern G.4:5, Intersection G.4:6, and Cistern G.4:8, dividing into upper and lower, then combining. There were some *huwwar* layers; several occupation layers, mostly of soil in dark, medium, and light brown ranging from powdery to crumbly; mixtures with small stones; or large-rock tumble. These varied layers extended

⁴ Saud Daud, a villager, reported that his father used Cave G.4:2 for animal shelter for the past 5 years and that his grandfather stored grain, straw, hay, and firewood for 40 years earlier; also that Tunnel G.4:4 was always blocked.

⁵ See Pl. XIV:B.

over a *huwwar* mound in the northwest corner of G.4:5, sealed up against a large stone near its center, and ended over the steps at the south end of Cistern G.4:8. Additional soil loci were found outside, sealing the vertical shaft above Cistern G.4:5.

Description (Architecture): Two floors were evident in Cave G.4:2—the cave floor itself and G.4:11a, composed of ceiling collapse supplemented by flat stones, relatively level except where it slanted downward to the floor of Tunnel G.4:4. In the opposite direction it joined with the bottom course of the cave's apparently contemporary enclosure wall, which rested on soil with no further foundation. Beneath soil Layer G.4:17 and Firepit G.4:19 south of the western tunnel, on the side wall was a bench carved out of bedrock, continuing south into the balk and apparently stopping on the north at the approach to the side tunnel.

Cave G.4:2 was a natural cave averaging 8.50 m. long, without tunnel extensions, and 4.00 m. wide (see Fig. 15). The smoke-blackened ceiling varied from 3.25 m. high at the cave entrance to 1.50 m. at Tunnel G.4:4 which measured ca. 1.50 m. high, ca. 1.35 m. wide, and ca. 2.65 m. long. This tunnel was clean, unplastered bedrock. Inside Cisterns G.4:5-9, all surfaces exposed gave evidence of having been plastered at one time.

In Cistern G.4:5 (see Fig. 15), measuring 10.15 m. long, 3.35-5.00 m. wide, and 2.50 m. high, the plaster on side and ceiling surfaces was easily removed but the well-preserved floor plaster was tough, adhering firmly to bedrock. A horizontal tunnel (ca. 2.00 m. deep, 0.90 m. wide) left the center of the northeast wall at ceiling level, with two footholes in the wall for steps beneath its opening. More than a half-dozen lamp niches were cut through the plastered wall surfaces, some ca. 1.00 m. from the floor, others near the ceiling. Soot deposits marked most of them.⁹ Near the center of the ceiling was a 0.60 m. x 0.80 m. vertical shaft cut through 2.75 m. of bedrock and continuing through another 0.50 m. of superstructure. Near Intersection G.4:6 was a crude retaining wall (G.4:65), measuring 1.00-1.25 m. high and 3.50 m. long, of uneven width. Its base was ca. 1.00 m. above the plaster floor, built upon four layers of Ayyübid/Mamlük fine gravel and brown soil above two layers of Byzantine sediment.

Cistern G.4:7 was non-functional during this period, having been filled with large stones and at least five column drums up to 1.75 m. long by 0.50 m. in diameter. Size and position of these drums demonstrated the presence of an as yet unlocated access to this cistern in addition to the mouth in the west corner of G.4:7. The top layer of the fill measured 4.70 m. northeast-southwest and 3.70 m. northwest-southeast. The ceiling at a level of ca. 876.61 was almost 1.00 meter higher than G.4:6.

Cistern G.4:8 slanted upward at 28° for 5.50 m. (horizontal distance) where it was sealed by a wall (not datable) of large stones. Smaller ones placed in the upper west segment allowed easy removal for exit. This cistern had two other access routes; a large vertical shaft blocked at bedrock by a fallen pillar and large stones; and a small side entry on the northwest wall near the west end, which became a round vertical shaft.

⁹ It was under one of these lamp niches that in 1973 the charred sherds of a Byzantine cooking pot were found embedded in chunks of charcoal.

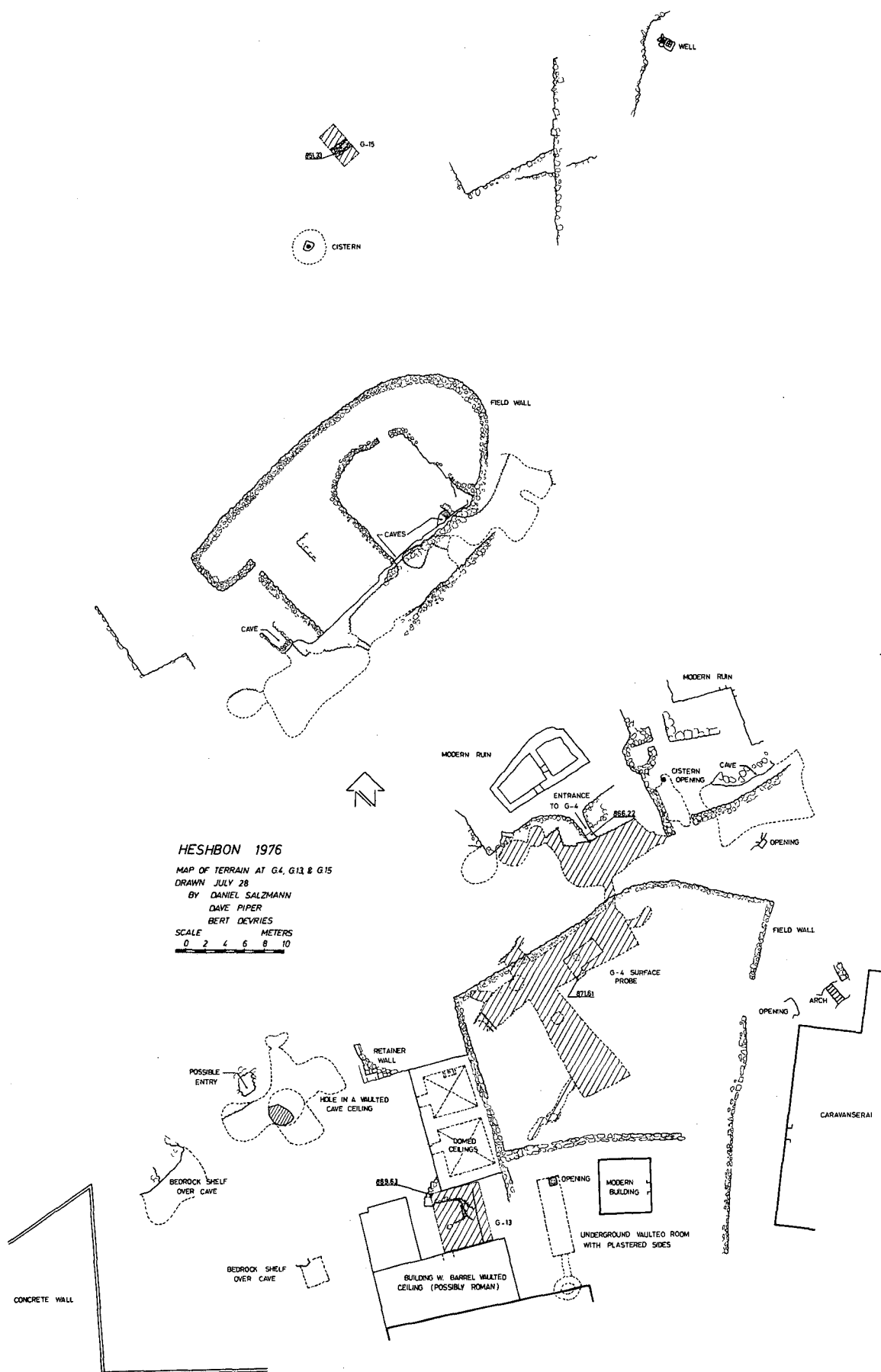

Fig. 14. Terrain map locating Squares G.4, 13, and 15, southwest of the acropolis.

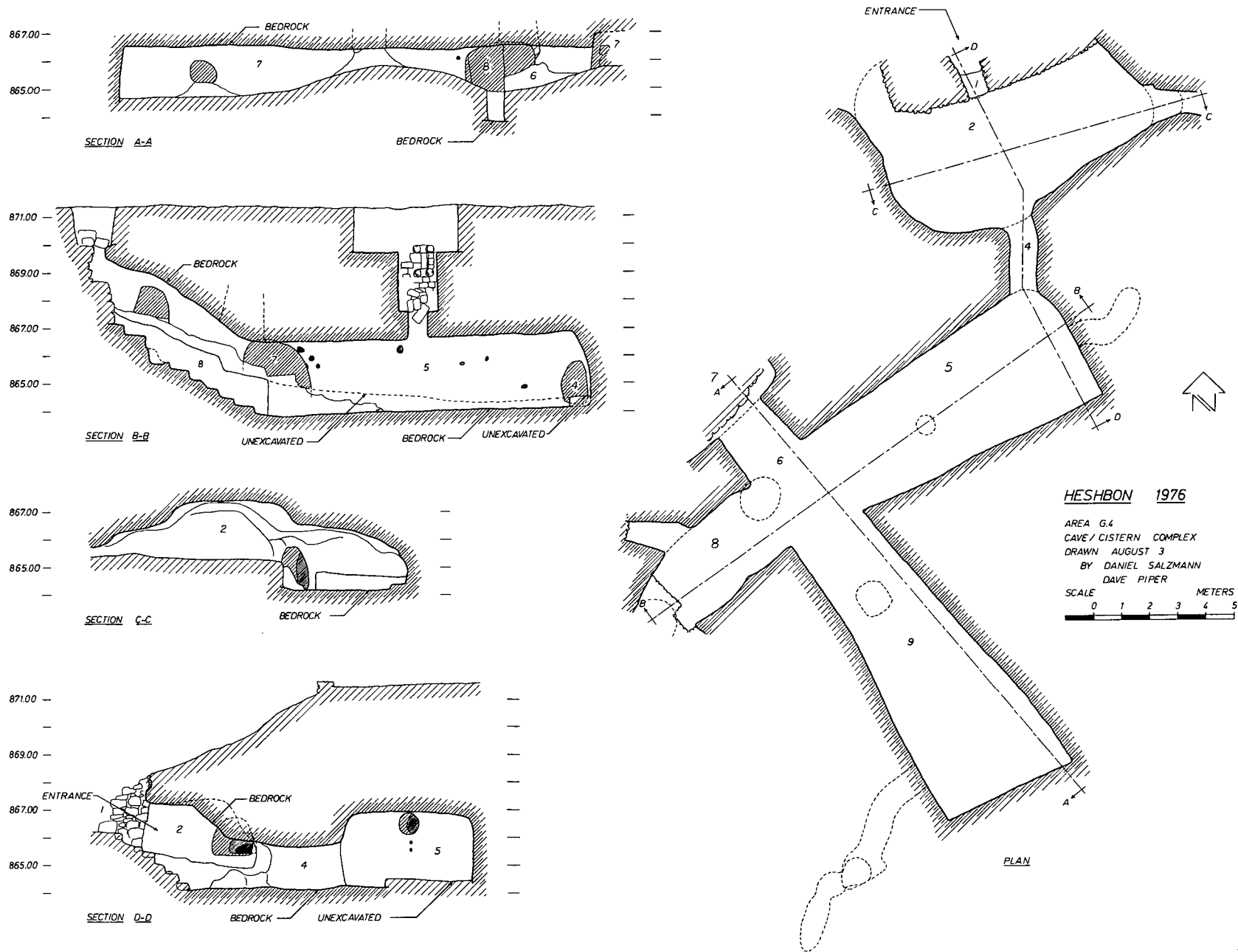

Fig. 15. Plan and sections of Cave/Cistern Complex G.4.

Cistern G.4:9, 3.25-5.00 m. wide x 10 m. long, was one-half to one-fourth filled, with a one-course semicircular wall abutting the far end. A water tunnel 6.00 m. long blocked with *huwwar* sediment entered the southwest wall 2.00 m. from the south corner. In the center of the ceiling was a 1.00 m. diameter vertical shaft partly blocked by a cone-shaped soil deposit. Outside, the only architecture of this period was a possible wall corner placed directly over the top of G.4:5 cistern Collar G.4:94.

Description (Bones): The Ayyūbid/Mamlūk loci produced the following bones: 246 sheep/goat, 37 chicken, 15 cattle, 24 large mammal, 4 cow, 3 horse, 1 pig, 2 fish, 2 dog, 1 rodent, 63 undistinguishable.

Description (Artifacts): A mendable Mamlūk sugarpot was found crushed in the north balk above Cistern G.4:5; it fit through the small opening of the top cistern Collar G.4:94. Other items registered as objects were:

2236	Stone Pendant	2359	Stone Disc
2277	Green Glass Tessera	2872	Nabataean Coin
2279	Two Stone Tesserae	2617	Iron Ring
2294	Iron Bar	2657	Iron Ring
2282	Whetstone	2658	Iron Hook

Interpretation: Cave G.4:2 was used extensively during this period, as indicated by the build-up from the bedrock floor to the later ceiling-fall-and-stone-pavement floor (G.4:11a). Firepit G.4:19 reflected some domestic occupation. The cave enclosure walls were constructed after Floor G.4:11a; then, after some build-up in the cave, Tunnel G.4:4 was hewn. No other traces of cutting were evident in G.4:2. A large *huwwar* mound (G.4:30) was left on the far end, inside Cistern G.4:5, on the plaster floor (which indicated that the cistern had been cleared). Access to the cistern complex and thus to Tunnel G.4:4 was gained through the opening at the top of the stairs in G.4:8.

Cistern G.4:5 itself saw several stages in this two-and-a-half century period. Layers G.4:41 and 45 a,b,c attested cistern use continued from 'Abbāsīd and Umayyad times. Later, when the installation was converted for domestic use, the slanting and partly mud-covered floor was stabilized by spreading *huwwar* Layer G.4:66 = 75, by partly removing soil deposits, and on the northwest end, clearing to the plaster floor. Then Tunnel G.4:4 was cut. Continued domestic use built up more floor layers. Another thin *huwwar* floor (G.4:62 = 72) was laid, level with the third step from the bottom of Cistern G.4:8. These stairs and the

tunnel at the other end were in use at the same time.

Gradually, however, the stairs were abandoned, perhaps during an occupation gap, leaving two access points open, one at the top of the stairs and the other near it, the tunnel leading off to the west.

Soil drifted, washed, or filtered into G.4:8, 6, and 5, and at one point a rock tumble occurred in G.4:8. A period of reoccupation saw the construction of the crude G.4:8 sealing wall, and later of the crude retaining Wall G.4:65, which reduced the usable space to Cistern G.4:5.

Stratum V: 'Abbāsīd (A.D. 750-969)

Description: Soil Layer G.4:97 lay above the olive press which was re-used as cistern Collar G.4:100, and sealed against the east side of the four-stone collar between G.4:100 and the top Collar G.4:94. Inside Cistern G.4:5 itself there were no purely definable 'Abbāsīd deposit layers.

Interpretation: The configuration of the loci containing 'Abbāsīd pottery in the layer immediately above the pure Umayyad Layer G.4:50 suggested that the cistern was used for water storage for a brief period at least.

Stratum VI: Umayyad (A.D. 661-750)

Description (Stratification): Soil Layer G.4:50 lay directly beneath the vertical shaft and directly over the plastered floor in Cistern G.4:5.⁷ Other layers from this Stratum appeared on top, around the Cistern G.4:5 shaft mouth, the uppermost (G.4:21) 0.25 higher than the top of cistern Collar G.4:94, another (G.4:99) sealed beneath the four-stone collar, and other soil and sediment layers.

Description (Architecture): Three collars were placed as a mouth over an almost completely blocked vertical shaft. Bottom Collar G.4:100, adapted from an olive press,⁸ was round with a 0.25 m. diameter hole in the center.

⁷ Suspicion of contamination of the ceramic samples taken on the second day in this locus occasioned an extended peeling of G.4:50 to the southeast of the datum line. Result: isolation and verification of G.4:50 Umayyad dating.

⁸ Comparable to the olive press found in Area D.6 in 1971. For location in Square, see Lawrence T. Geraty, "Heshbon 1971: Area D," *AUSS* 11 (1973): 102, Fig. 6; also *ibid.*, p. 110, for dating of appropriate loci, although the olive press is not mentioned there explicitly. The orifice of the press would be small enough to prevent children and thirsty small animals from falling into the cistern.

The second, built of four stones, supported the top collar (G.4:94), a single square stone with a 0.25 m. hole. To the northeast and on bedrock was the bottom course of a wall with one probable door socket visible, and parallel to the wall a smoothly cut (or worn) channel, possibly a water channel for Cistern G.4:5. The vertical shaft itself was oval, 1.00 m. to 1.25 m. wide. It was filled with large stones, except for a small shaft crowned by the collars.

Interpretation: The cistern was used only for water storage during this period, after an earlier period of domestic occupation when the shaft was filled with stones. With earlier occupation traces removed from the bedrock above, buildings were constructed conveniently nearby, and the first collar put in place. Gradually continued use was evidenced by the soil accumulations which necessitated higher collars: the four-stone supporting collar and the monolithic Collar G.4:94. Finally, a possible wall placed near the mouth without sealing it may have prevented the drawing of water while allowing its collection. This possibly explained why the later 'Abbāsīd locus appeared only on one side of the mouth. Use continued into still later periods, but with little efficient water collection, allowing a return to domestic occupation of the cistern complex.

Umayyad pottery Handle 2825 was a circular mount attached to the shoulder portion of a rounded vessel. The bottom portion was missing. The top was perforated in a simple design which probably extended around the circumference of the vessel, perhaps several times. The holes may have been vents in a lantern or a strainer on a vessel for drawing clean water.

Strata VII-VIII: Late Byzantine (A.D. 450-661)

Description (Stratification): All layers from these Strata tilted down from the stairs in G.4:8, one from as high as the third step from the bottom. (The surface layer [G.4:47] on the dump in G.4:7 was a completely distinct phenomenon.) Sediment layers continued relatively level through the intersection and about one meter into G.4:5, where the well-sorted, mostly water-laid sediment was severely disturbed by later activity. In the exceptionally dry Byzantine clay Layer G.4:39 large cracks 0.01-0.04 m. wide and ca. 0.07 m. deep broke its surface into flagstone-like blocks, and this clay mud deposit shrank ca. 0.03 m. from the cistern wall. Though Locus G.4:38 was dated Early Roman, a Byzantine date was almost certainly required by the context; and occupation Layer G.4:67, with one Ayyūbid/Mamlūk (probably intrusive) sherd, could have been contemporary with Pit G.4:86.

Description (Architecture): Storage Pit G.4:86 was dug into the large stairway of G.4:8 where the third step from the top had been removed. The 0.40-0.60 m. oval, unplastered pit had a slanted top opening which allowed for 0.45 m. depth in the back and 0.15 m. depth in the front. Presumably the lip, ca. 0.05 m. wide, once held a lid.

Numerous unplastered lamp niches (many of them sooty) were found carved into the plastered cistern walls, at least six in G.4:5 (half of them carved within 1.00 m. above the cistern floor, the others near the ceiling) and one in each of the eight walls at the four corners at Intersection G.4:6.

Interpretation: Deposits indicated that the cisterns were used first for water storage during this period,⁹ then later converted for domestic purposes. The two lamp-niche levels permitted both general lighting from the high niches and close lighting from the lower niches (which were too low to have been intended for use in animal shelters).

Remodeling for domestic use included partial cleaning (in which process the one Late Byzantine intrusive sherd could have been trampled into an Early Byzantine sediment layer; or brought in subsequently by rodent tunneling, presently visible only in the balk of G.4:83). The vertical opening in G.4:5 was blocked with boulders and stones, and the wet mud was removed as far as the point where the sediment was firm enough to support body weight, though several large chunks that broke loose during use remained.

This period also saw the use, if not the digging, of Pit G.4:86 in the stairway of G.4:8. The evidence suggested that this pit was finally allowed to fill with erosion debris. (A report from flotation samples was not available at this writing.)

The charcoal in all associated loci may have been washed in, but large concentrations of it within the chamber of Cistern G.4:5 gave evidence of fire there. In addition, in 1973, charred Byzantine cooking pot sherds had been also found under a lamp niche on the northwest wall of G.4:5. Within 1.00 m. west of the fire remains

⁹ The color of the clay attested an extremely long occupation in the vicinity of G.4. See Harold E. James, Jr., "Geological Study at Tell Hēsbān," *AUSS* 14 (1976): 165-169, esp. p. 166. The loose red residual and sandy soil found mostly in later strata attested deep disturbances of preoccupation levels above bedrock, probably during building operations which destroyed all clearly definable earlier occupation levels.

were the mud chunks dubbed as "Flagstone" G.4:39. The cracks in G.4:38 were caused through drying by the fire. This clay also could have served as a bench during the period of domestic occupation. As the cracks appeared, they were filled with debris. The evidence did not attest a long domestic occupation. The suggestion that the conversion was due to an emergency has some merit. Defense requirements could have accounted for the filling of Cistern G.4:7.

Strata IX-XIV: Early Byzantine (A.D. 324-450)

Description: The oldest sediment layers were G.4:83 in G.4:8 = G.4:76 in G.4:6 (a relatively level well-sorted 0.10-0.15 m. thick sediment layer containing small sherds covered the bottom stair in G.4:8) and the lowest sediment layer, G.4:85 = G.4:87 in G.4:6 and G.4:71B in G.4:5. These deposits rested directly on the smooth and intact plaster Layer G.4:102 laid directly upon bedrock.

Interpretation: It is possible that the G.4:6 lower strata were never cleared of sediment. If so, heavier infiltration of sherds might be expected. More likely, the relatively new cisterns were cleaned regularly, and any Roman loci there were lost.

Strata XV-XIX: Roman (63 B.C. - A.D. 324)

Description: One significant Early Roman layer (G.4:27) was attested on two of the upper stairs, above storage Pit G.4:86. This layer was sealed over with a black pitch-like substance that continued 0.01-0.02 m. thick over most of the stairs; large portions were broken away. The lower stairs contained no datable evidence. Associated architecture was the stairs themselves, nine steps in all. The east wall of Cistern G.4:8 was uneven because of a large crack in the bedrock, sealed by several plaster layers. A slab of ceiling bedrock may also have fallen. The latest pottery from the stairs was Early Roman; the latest from the plaster in all the cisterns was Late Roman.

Interpretation: The cistern complex in its present architectural form dated from the Early Roman period. The originally soft pitch-like sealer retained the water under heavy traffic conditions for which plaster would have been too brittle. The stairs may have extended beyond the present blocking wall to a level nearer that of the bedrock ceiling. The extent of Early Roman plastering was not clear, but Late Roman completion was certain. A possible cause of the fissure in the wall was the earthquake of 31 B.C.

If the cistern complex had been fully cut at that moment, however, more extensive damage might be expected. Perhaps it is more plausible to date the present installation to Early Roman II at the earliest, without precluding the evolution of the complex from several smaller units. Another complex nearer G.13, suggested that two originally separate installations were subsequently connected by the cutting of a third.

Summary and Conclusion

An Early Roman "walk-in" cistern and several neighboring vertical-shaft cisterns were enlarged, joined in a single complex. The porous *nari* limestone was sealed and in Late Roman times it was completely coated with a firm 0.01-0.02 m. plaster or cement. Numerous inlets received water, while the large stairway allowed water to be taken out easily. Esihus continued to rely on this installation until, in Late Byzantine times, the complex was converted to domestic purposes. Water inlets were blocked and the greater portion of G.4:5 was cleaned of sediment. High lamp niches were installed at critical points, such as at corners, and low niches for more direct lighting.

When the Umayyads took control of this region the installation was needed for water storage. All but the fine debris and heavy sediment was removed from within the cistern. The vertical shaft of Cistern 5 was partially re-opened and crowned with the dressed round stone from an olive press; then with additional collars as soil built up. At least one building was erected adjacent to the mouth.

'Abbāsīd domination left trace of no changes, only of slight use and then of abandonment.

In Ayyūbid/Mamlūk times this installation was still a serviceable water source. However, numerous other underground depots for wet or dry storage existed in the immediate vicinity, and with the new flourishing occupation, surface accumulations increasingly absorbed and dissipated water away from the G.4 complex. The wide stairway invited the owner to return it to domestic

use. So he cleaned it out and created a somewhat level surface covered with finely pulverized limestone to about 3.00 m. from the far end, where he exposed the cement floor. Later dirt accumulation required another thin floor layer of limestone.

What was the source of limestone bits and chips? Another project, Tunnel G.4:4, which now connected G.4:5 with G.4:2. The level and relatively smooth cave floor gradually accumulated gravel and dirt dropped from the overhead ledge. Later, part of the ceiling fell. A flat slab of *nari* limestone imbedded itself as a partial floor. The floor was completed with large flat stones. An enclosing wall sealed the mouth of the cave, all but the 1.00 m. wide Entrance G.4:1. Accumulation near the entrance required steps leading down into the complex.

By this time all other entrances to the cistern complex had been blocked by infiltration of dirt and stones. Only G.4:5 was preserved for use by the construction of the crude retaining Wall G.4:65. So it remained through abandonment until Ottoman and Modern times.

Little, if any, use was made of G.4:5 thereafter because Tunnel G.4:4 was blocked with stones and rubbish. Finally, Cave G.4:2 was divided into two pens by a low wall. A few cattle were kept in the lower pen, probably during the winter. During summer months the entrance was blocked with stones, the condition in which it was found in 1973.

About mid-season, 1976, the Jordanian Department of Antiquities proposed that the entire cistern-cave complex be cleared and designated as the Heshbon Museum. To this end measurements were taken to install an iron gate to preserve the cisterns from abuse until such time as the museum plans could be realized.

SOUNDING G.13

About 40 m. south-southwest of G.4 and 30 m. west of the southwest corner of the caravanserai, the partially exposed

ancient ruins of a stone and mortar installation lay nestled between a two-room double-domed building and a possibly Roman building, which had a barrel-vaulted ceiling and arched windows almost totally submerged. Both buildings were used to store straw during the winter months. Cleanup and excavation began at the benchmark 868.98 m. The purpose of the sounding was to date and identify the stone and mortar architecture (top level: ca. 872.00 m.) and to date the building with a barrel-vaulted ceiling.

Stratum I: Modern (A.D. 1870-1976)

Description: This Stratum comprised two loci: recent, still bacteriologically active garbage, and below this, moist black topsoil—containing many worms, large rocks, a few bones, Ottoman and Modern sherds and many modern objects.

Interpretation: Extremely high moisture content in the soil illustrated how well suited the architecture in this Square was for collecting water. It gave the stratigraphic context for the transitions from Stratum II to the Post-Stratum II gap, and from the Post-II Gap (Ottoman) to Stratum I.

Strata II-IV: Ayyūbid/Mamlūk (A.D. 1200-1456)

Description (Stratification): Locus G.13:3, a 0.15 m. layer of tan-orange hard chalk mixed with soil, covered most of an occupation layer (G.13:4) embedded with plaster tile bits, chaff, and charcoal. A thin cement layer (G.13:5) occurred totally within the context of G.13:3. In the southwest portion of the Square, away from the originally visible architecture, a possible foundation trench (G.13:6) and wall (G.13:7) were scant signs of intentional construction. Several thick soil layers contained numerous small boulders.

Near the visible architecture, just below its cement Surface G.13:8 was a narrow, shallow (0.25 m.) plastered divider (G.13:15) which opened towards an arched opening (G.13:9). At 0.40-0.50 m. lower were several associated loci: a single-course L-shaped wall (G.13:18) of rather heavy stones; a plaster layer (G.13:19) with embedded charcoal bits in the southwest corner of the Square; possible pavement stones (G.13:21) southeast of Wall G.13:18; an occupation layer (G.13:23); and related loci 22 and 24, all of which were inside L-shaped Wall G.13:18; also two wall fragments, G.13:25 and 27.

Description (Bones): The following bones were found mostly in the upper loci: 22 sheep/goat, 2 cattle, 6 large mammals, 5 chicken, 15 undistinguishable.

Description (Artifacts): The latest pottery from these layers was Ayyūbid/Mamlūk. The following items were registered as objects:

2604	Hook	2612	Glass base
2620	Ring	2614	Bead
2624	Key	2602	Bead
2718	Nail head	2438	Iron fragment
2607	Bronze lid	2613	Glass bead

A large quantity of tesserae and clay tiles were also excavated.

Interpretation: The majority of soil loci were homogenous in texture, frequently distinguished only by architecture which was never distinct enough to suggest specific functions except for the possible small water channel (G.13:15) from the cement Surface G.13:8 to the plastered Archway G.13:9. Architectural remains indicated that this installation was not used for water prior to construction of Channel G.13:15; only during its use was a water route into a reservoir possible. Most of the time the architecture was entirely independent of arched Opening G.13:9, suggesting that the earlier complex was purposely ignored for most of the 10th to 15th century. Probably, since only one bucket contained 'Abbāsid sherds, this lot was abandoned from ca. A.D. 750.

Stratum VI: Umayyad (A.D. 661-750)

Description: Stratum VI loci which were above the plastered or cemented surfaces suffered later intrusions. The upper and outer face of arched Entrance G.13:9 was constructed of small symmetrical rocks with mortar. The inside of the entrance, 2.00 m. high x 0.75 m. wide, had been plastered several times. The upper half of the passageway was cleared for a length of 2.50 m. To the right of this arched entrance and 0.65 m. above its outer face lay a 2.00 m. x 1.50 m. platform, part of the original construction.

Wall G.13:10 (0.30-0.50 m. thick) ran 2.25 m. north-south above and around the arch. Parallel with and between it and a vertical bedrock surface ran north-south stone-and-mortar Wall G.13:11, 0.90 m. wide, surviving 2.15 m. above the arched entrance, to a level of 871.25 m.; it ran 4.50 m. from stone-and-mortar east-west Wall G.13:12 to 1.00 m. from the south balk. Wall G.13:12 (3.40 m. long), survived 0.25 m. higher than G.13:11. Its interior face was once covered with Plaster G.13:13 = 26, the same as the cement on the top, sides and floor of the arched passage and on the face coming down from the platform (connecting with the bases of G.13:11 and G.13:10) and curving to become the bottom of a storage tank which continued under the west balk. The makeup (G.13:29) for the cement basin was of small stones laid over bedrock. On the south side the plaster ran to the west base of the arch of the barrel-vaulted building. Plaster samples were taken for laboratory analysis. There was a 0.50 x 0.50 m. indentation in the tank floor at its southeast corner, which indicates that the plaster never continued farther southeast.

The portion not covered by intact plaster was composed of loose gray soil and small pebbles.

Interpretation: An Umayyad structure, later than the adjacent building, rendered one of its archways nonfunctional. The large number of clay tiles found in Fill G.13:17 was conceivably part of the vertical substructure of the plastered wall. A stack of these tiles remained *in situ* in the build-up next to the vertical plaster G.13:26 on the lower east wall. The plastered floor slanted toward the arched entrance, suggesting that water may have been collected in the tank and drained through the arch into a cistern.

The southeast indentation in the floor, approximately the same width as the Walls G.13:10, 11 and 12, could have been the location of part of the south wall blocking the archway. However, it did not go far enough to allow sealing against the west arch support on the south wall. This remained unexplainable because the plaster disappeared into the south balk at the archway. Further sounding might show continuation into the earlier arched structure. Enclosure Walls G.13:11 and 12 presumably joined two other enclosure walls at undiscerned locations.

Less than 5.00 m. east of Arch G.13:9 lay a similar plastered complex, completely underground, at about the same level as G.13. It was composed of two chambers (one small and rounded, ca. 2.50 m. in diameter; and the other rectangular 3.00 m. x 7.80 m.) connected by an arched passageway of approximately the same height, width, and known length as G.13:9 and finished with a similar plaster or cement on every surface except the vaulted ceiling. This surviving parallel installation may possibly serve as a basis for considering the original design of structures in G.13.

SOUNDING G.15

Downhill, north of the G.4:1 cave entrance, lay the exposed mouth of a partially dirt-filled bell-shaped cistern. Its vertical shaft ran ca. 3.00 m. from a carved capital re-used as the cistern mouth to a bedrock shelf. Two water channels in the bedrock

below were visible where they entered the cistern on the east and west.

The partially exposed top course of an ancient wall ran north-east-southwest (designated north-south for the sake of simplicity), its top at the 851.33 m. level. Sounding G.15 transected this wall ca. 10 m. northeast of the cistern at a point 285 m. from the primary benchmark on the *tell*.

Stratum I: Modern (A.D. 1870-1976)

Description (Stratification): Locus G.15:1, covering the entire 2.00 m. x 5.00 m. Square, slanting ca. 0.90 m. down, toward the northwest, was pale brown (top) soil 0.06 m. to 0.12 deep with primary root growth and fist-sized stones. It covered a portion of Wall G.15:2, all of Wall G.15:8, soil Layer G.15:3 east of Wall 2, and soil Layer G.15:4 (probably Umayyad) west of the wall.

Description (Bones): 58 sheep/goat, 3 pig, 5 large mammal, 1 chicken, 4 cattle, 1 donkey, 20 undistinguishable.

Description (Artifacts): Registered artifacts included:

G.15:1	2637	Horseshoe nail	2654	Ivory needle
G.15:3	2694	Modern buckle	2695	Bronze needle

Interpretation: Ground surface loci were typical. The concentration of bones did not seem unusual. Possibly the upper portion of soil Layer G.15:12 also belonged to this period. The main architectural fragment was certainly below the Modern stratum.

Strata II-IV: Ayyūbid/Mamlūk (A.D. 1200-1456)

Description (Stratification): East of Wall G.15:2, soil Layer G.15:3 lay over Wall G.15:8 = 2. This wall was sealed against by a thick tumble layer (G.15:3, 7 = 9 = 10 = 11 = 12 = 15 = 16 = 19 identical in color and composition) and six soil layers (Loci 17, 18, 20, 23, 25, and 26).

Packed clay Layer G.15:22 covered the entire Square east of Wall 8 = 2. It supported crude semi-circular Wall G.15:21, which abutted Wall 8 = 2 at both ends and contained yellow-red fine clay soil Layer G.15:20.

Ayyūbid/Mamlūk occupation Layer G.15:23 also extended to the eastern limits of the Square. Under it lay first, red-yellow soil Layer G.15:24 (without pottery); then brown clay soil Layer G.15:25, and, finally, brown clay occupation Layer G.15:26, which contained yellow clay particles, charcoal bits and olive pits. Upon it, in the southeast corner of the Square, rested *tabun* floor Fragment G.15:30 into which was cut Pit G.15:28, which in turn held fire Pit G.15:27, composed of stones.

Under soil Layer G.15:26 and over bedrock at the 848.01 m. level in the

same southeast corner was Pit G.15:29, also round, 1.00 m. in diameter and 0.60 m. deep.

Description (Architecture): The only intact architecture of this period was Wall 15:8 = 2, which was sealed against by many loci, most containing large, carefully trimmed tumbled stones. The *tabun* fragment, firepit and the crude semicircular wall have been described above.

Description (Bones): All from Locus 7 were 12 sheep/goat, 1 chicken, 1 cattle, 2 undistinguishable.

Description (Artifacts): Registered objects were:

2891	Islamic lamp	2886	Possible stone weight
2881	Mamlūk coin	2865	Slingstone

Interpretation: Only in the sector nearest the cistern did Strata II-IV occupation evidence extend to relatively level bedrock. Considerable occupation, probably domestic, was associated with lower Strata II-IV loci, which contained the only objects in these layers. Proximity to the cistern was undoubtedly an attraction. The dating of the single Mamlūk coin was not clear enough to fix the occupation period more narrowly than the 13th to 15th century. The at-least-seven-course Wall 15:8 = 2 was sealed against by loci of earlier strata, hence was used by Strata II-IV occupation.

The homogeneity of the upper loci suggests that the filling of the cavity between the wall and the cistern took place in a relatively short time, possibly during a single earthquake or other destructive event. If the fill was not deliberate, the cistern mouth might have been blocked and lost, as has happened elsewhere on the *tell*.

On the east side of Wall G.15:8 = 2, except for Pit G.15:29, the sequence of these layers began several stages above bedrock. It may have ended with the placement of the new cistern collar, an old decoratively carved capital with a hole cut through the center large enough to allow water buckets to pass through it.

Stratum VI: Umayyad (A.D. 661-750)

Description: One locus, G.15:4, yielded clear information relevant to this Stratum. It ran west from Wall G.15:8 = 2 to lens out between Modern Locus 15:1 and Late Roman Locus 15:14 about 0.30 m. from the west balk. The soil was light brown clay with limestone inclusions.

Interpretation: Given the preponderance of Umayyad sherds in lower loci east of Wall 15:8 = 2, e.g. G.15:22, 25, one may postulate a subsequent Ayyūbid/Mamlūk contamination of some originally pure Umayyad Stratum VI loci.

Stratum VII: Late Byzantine (A.D. 614-661)

Description (Stratification): Foundation Trench G.15:5, on the west face of Wall G.15:2 (which survived in only two courses) ran the full width of the Square, ca. 0.15-0.20 m. wide and 0.20 m. deep. It cut into G.15:6, a reddish clay layer (similar to Locus 4) which covered the entire west half of Square except for Late Roman Locus 14.

Description (Architecture): Wall G.15:2, surviving in two courses, is dated to this Stratum by its foundation trench (no part of the rubble fill between G.15:2 and G.15:8 was examined). The west face of G.15:2 was made of smaller sized and better cut or less weathered stone than the G.15:8 face.

Description (Bones): The loci contained the following bones: 1 sheep/goat, 1 cattle, 2 scrap.

Interpretation: The G.15:2 wall face was later than its counterpart, which extended a full five courses below it. The difference in weathering was little or no indication of greater age. It seems unlikely that a single wall would be built with one high foundation trench and no lower foundation trench. It is likely that both G.15:2 and 8 originally had more courses upon them, but were robbed out later.

Strata VII-XIV: Byzantine (A.D. 324-661)

Description: Surface G.15:31 was a pale brown soil (0.07-0.10 m. thick) with small stone inclusions. It disappeared under Wall G.15:8, which rested upon it. Wall G.15:8 survived seven courses high, rising 2.65 m., the upper 0.71 m. of which was faced on the west by Wall G.15:2. Rubble fill connected the two faces creating a wall 1.10 m. thick. The thickness of the wall below level 850.56, the bottom of G.15:2, was not determined. The latest associated pottery was with some uncertainty classified Early Byzantine with Late Roman dominant.

Interpretation: If Surface G.15:31 was indeed Early Byzantine, belonging to Strata IX-XIV, and the secondary face belonged to Late Byzantine Stratum VII, G.15:8 could have been built in either period. In any case, the paucity of occupation layers suggested comparatively little activity here. This was hardly a Byzantine wall because Late Roman strata appeared outside

it less than a meter from its top surviving level. It could have been a retaining wall, dressed on the outside with G.15:2, built possibly to prevent collapse into a thoroughfare or into a courtyard where a cistern was.

Strata XV-XVI: Late Roman (A.D. 135-324)

Description: Six loci are involved here, two west and four east of Wall G.15:8 = 2. Hard-packed Locus G.15:13 was not excavated except for the one pail of Locus 6 pottery. Locus G.15:14 was a loosely packed pit with the characteristics of a foundation trench.

On the east side of G.15:8 = 2, a layer of red-yellow soil and clay became Locus 33, rubbly with clay inclusions. Beneath these was Surface G.15:34, a strong brown clay/sand compound with a few stones, covering plaster Layer G.15:35, a pale brown *huwwar* and sandy substance remaining only in irregular patches upon G.15:36, bedrock. The latest pottery was probably Late Roman IV, with Late Roman I, II, and III more clearly and abundantly represented.

Interpretation: Late Roman Locus 6 in the west half of the Square ran beneath Byzantine Wall G.15:2. Since Wall G.15:8 was not yet constructed we must presume a very steep drop (1.50 m. vertical drop in 1.25 m. horizontal distance) from G.15:13 on the west to G.15:32 on the east half of the Square, or an earlier, thinner wall (from the present evidence the only reasonable alternative).

The plaster (G.15:35) used to level irregularities in Bedrock G.15:36 was a luxury hardly warranted by a thoroughfare or even a courtyard. A more reasonable hypothesis was that this sounding came upon a domicile whose west wall retained the great amount of soil accumulation now on the west side. That Late Roman layers were so high there suggested a long period of time elapsed under these circumstances. On the east uphill side there was ample space to have allowed the domicile to open onto a courtyard or a thoroughfare between the Area F cemetery and the acropolis itself.

AREA G.11, 16, 17, 18

ROBIN M. BROWN

University of Michigan
Ann Arbor, Michigan

AREA G.11

Area G.11 was opened as a 3.00 m. x 3.00 m. Square on the north slope of Tell H̄esb̄ân, northeast of Area C and overlooking the Wadi el-Majarr. The sounding was intended to investigate the stratigraphic sequence on this slope. Visible over much of the ground surface of the north slope was a complex network of architectural features. These features included several circular depressions, which were surrounded by walls, and also other architectural or terrace walls. The walls were poorly preserved throughout, but their remains did indicate that their original construction had been chiefly of uncut or only roughly cut boulders. One of the objectives governing the specific orientation of the Square was the investigation and dating of such collapsed walls, some of which appeared to be at right angles to one another. Thus the south balk of G.11 was set to bisect an east-west wall and the west balk was set to bisect an adjoining north-south wall. Another factor involved in choosing the location was that the ground surface was not sunken, which was interpreted as indicating a lessened probability of intersecting a cistern.

The stratigraphy associated with Wall G.11:9 necessitated the subsequent expansion of the Square northward by 1.00 m. thus increasing the overall dimensions to 3.00 m. east to west and 4.00 m. north to south. This Square was excavated from 21 June to 19 July.

Strata II-III: Mamlūk (ca. A.D. 1260-1456)

Description: Soil Layer G.11:1, 2, and 16 extended across the entire Square and lay over a *terra rossa* soil layer (G.11:3, 4, and 17). The earth matrix consisted of top soil and dry, crumbly gray earth mixed with pebbles of *huwwar* and limestone, and with cobbles and boulders of limestone as well. This rock

rubble constituted approximately 50 percent of the matrix. The top levels ranged from 886.48 m. to 885.66 m. and the bottom levels ranged from 885.61 m. to 885.65 m. The average depth was 0.30 m.

Terra rossa soil Layer G.11:3, 4, and 17 extended across the entire Square and lay over soil Layer G.11:5 and foundation Trench G.11:20. The earth matrix consisted of *terra rossa* soil of varying degrees of compaction mixed with localized patches of loose brown soil (except in the central and eastern portions) and rock rubble. The latter included pebbles, cobbles, and boulders of limestone as well as *huwwar* chips and totaled approximately 50 percent of the entire matrix. The average depth was 0.30 m.

Foundation Trench G.11:20 and 25a was located in the northeast corner of the Square. It measured at maximum 1.30 m. east to west x 1.40 m. north to south. To the south it met the north face of Wall G.11:9 and sediment Layer G.11:18 and 19a. The earth matrix of the upper portion consisted of loose, granular gray soil mixed with flecks of charcoal and a few small patches of compacted *terra rossa* soil. The lower portion of the trench was characterized by a loose fill of dark gray granular soil mixed with small and medium sized cobbles of limestone and numerous air pockets where the soft soil had subsided. The rock rubble constituted approximately 50 percent of the total matrix. Clustered in the corner where the north and east balks met were several cut blocks of stone tightly wedged together. These stones were part of the upper portion of a cistern structure. The top level was 885.16 m. and the bottom levels ranged from 884.20 m. to 883.51 m. The average depth was 0.90 m.

Cistern G.11:26, located in the extreme northeast corner of the Square, lay beyond the foundation Trench G.11:20 and 25a. Only a few centimeters of this structure were actually within the Square and therefore it remained unexcavated. Its structure included a vertical corridor which had been cut into limestone bedrock. The top of the bedrock scarp had been built up with stone walls and a roof. Plaster had been applied over the interior face of the shaft.

A soil layer (G.11:58, 11, 13, 18, and 19a) was located across the entire Square except in the northeast corner. It lay over soil layers (G.11:12, 14, and 19b) and Wall G.11:9. In the northeast corner it was cut by foundation Trench G.11:20. The earth matrix consisted of lightly compacted granular brown soil mixed with rock rubble which constituted approximately 65 percent of the total matrix and included pebbles of limestone and *huwwar*, and cobbles and uncut chunks of limestone. The average depth was 0.75 m.

Soil Layer G.11:19b lay in the northwest corner of the Square over *terra rossa* soil Layer G.11:21a. It measured 2.10 m. east to west x 1.50 m. north to south and touched the north and west balks. To the south it met the north face of Wall G.11:9 and on the east it was cut by foundation Trench G.11:20. The earth matrix consisted of light brown granular soil mixed with patches of dark brown granular soil and compacted *huwwar*. A few small pebbles of limestone were also present.

Terra rossa soil Layer G.11:21a was located in the northwest corner of the Square and lay over *terra rossa* soil Layer G.11:21b. To the south it met the north face of Wall G.11:9 and on the east it was cut by foundation Trench G.11:20. The earth matrix consisted of firmly compacted *terra rossa* soil mixed with *huwwar* chips and small to medium-sized limestone cobbles. The latter

were clustered along the north face of Wall G.11:9 where the *terra rossa* soil was less compacted. The average depth was 0.10 m.

The dating of these loci to the Ayyūbid/Mamlūk Strata II-III was based upon the latest sherds in the ceramic assemblages.

Interpretation: Soil Layer G.11: 1, 2, and 16 contained a few scraps of metal but no post-Ayyūbid/Mamlūk pottery. As described above, the remains of a network of walls were intercepted in order to date and identify associated foundation trenches and surfaces. No such features were identified as associated with the "walls," one of which (extending parallel and adjacent to the west balk) did not appear to have been a wall but a cluster of stones. The other (extending parallel and adjacent to the south balk) was superficially constructed. These late walls seemed to represent a subphase of Ayyūbid/Mamlūk occupation, and on the north side of the *tell* this was clearly the last phase of building to have been initiated. The lack of domestic artifacts and features indicated that these late walls may have been terrace walls for soil retention or boundary walls marking property division.

Terra rossa soil Layer G.11: 3, 4, and 17 and soil Layer G.11: 1, 2, and 16 represented accumulation without occupation or internal cultural stratigraphy. Since many boulders were embedded in both these layers simultaneously it appears that the process of collapse and sloping downward of destruction debris had been a natural process responsible for a large amount of deposition prior to the construction of the late walls.

Foundation Trench G.11:20, 25a had been cut from the top level of soil Layer G.11:5-8, 11, 13, 18, and 19a for the construction of Cistern G.11:26. Earth had been hollowed out in order to build the cistern's upper walls and roof, and after that had been completed the remaining space was backfilled with rock rubble and soil. It seemed that after the cistern was completed, *terra rossa* soil Layer G.11: 3, 4, and 17 formed over it. However, the limited exposure of Cistern G.11:26 does not lend itself to conclusive evidence, and it remains possible that in the process of the construction of the cistern the trench was cut out from under

soil Layer G.11:3, 4, and 17. Pottery from both within the trench and the top of the soil pile in the cistern was dated Ayyūbid/Mamlūk indicating that both the construction of the cistern and its latest phase of abandonment were in that period. Although even on the basis of stratigraphy alone Cistern G.11:26 seems to have been a subphase of the Ayyūbid/Mamlūk period, no more precise dating could be given for it.

Soil Layer G.11:5-8, 11, 13, 18, and 19a represented natural accumulation during the Ayyūbid/Mamlūk period. This massive deposition of rock rubble and sediment fill must have resulted from the erosion downward of large amounts of destruction debris from abandoned structures and/or terrace walls farther up the slope. This debris accumulated against the south face of the bedrock scarp (G.11:10) and spilled over it and Wall G.11:9 as it sloped down the *tell* northward. It appears that some sorting took place, for though there were a few boulders scattered over Wall G.11:9 there were none north of it. Both *terra rossa* soil Layer G.11:21a and soil Layer G.11:19b represented soil accumulated during the Ayyūbid/Mamlūk period, but they were the result of natural erosion processes.

Stratum VI: Umayyad (ca. A.D. 661-750)

Description: *Terra rossa* soil Layer G.11:21b and 22 was located in the northwest portion of the Square and lay over soil Layer 23a. It measured 2.10 m. east to west x 1.10 m. north to south and touched the north and west balks. On the south it met the north face of Wall G.11:9 and on the east it was cut by foundation Trench G.11:20. The earth matrix was characterized by compacted *terra rossa* soil mixed with a few small cobbles and pebbles of limestone, flecks of charcoal, and chips of *huwwar*. Localized along a short portion of the north face of Wall G.11:9 was a patch of lightly compacted *terra rossa* soil mixed with numerous limestone cobbles. Towards the northwest corner of the Square the *terra rossa* soil became increasingly compacted. The top level was 884.62 m. and the average depth was 0.30 m.

Soil Layer G.11:23a was located in the northwest portion of the Square and lay over *terra rossa* soil Layer G.11:23b. It measured 2.40 m. east to west x 1.40 m. north to south and touched the north and west balks. On the south it met the north face of Wall G.11:9 and on the east it was cut by foundation Trench G.11:25a. The earth matrix consisted of uncompacted granular gray soil mixed with pebbles and small cobbles of *huwwar* and limestone. The top

levels ranged from 884.44 m. to 884.23 m. The depth ranged from 0.05 m. to 0.25 m.

The dating of these layers to Umayyad Stratum VI was based upon the latest sherds in the ceramic assemblage.

Interpretation: Though the soil layers which were deposited in this stratum had no direct cultural significance but were rather natural accumulations of sediment and debris, they do attest Umayyad occupation elsewhere on the *tell* by the pottery which was incorporated into these layers during deposition. This Umayyad pottery is present only north of Wall G.11:9. The wall probably continued to function as a retaining wall in this period.

Stratum VII: Late Byzantine (ca. A.D. 614-661)

Description: A *terra rossa* soil Layer (Locus G.11:23b) lay in the northwest portion of the Square over *terra rossa* soil Layer G.11:23c. It measured 2.40 m. east to west x 1.40 m. north to south and touched both the north and west balks. On the south it met the north face of Wall G.11:9 and on the east it had been cut by foundation Trench G.11:25a. The earth matrix consisted of compacted *terra rossa* soil interspersed with patches of crumbly brown soil and pebbles of limestone and *huwwar*.

This layer was dated to the Late Byzantine Stratum VII on the basis of the latest sherds in the ceramic assemblage.

Interpretation: No associated architectural or occupational features existed in relationship to this layer except for Wall G.11:9 against which this soil accumulated. Thus it appeared that this deposition was without cultural stratigraphic significance, although Wall G.11:9 may have continued in use in this stratum. There was no specifically Late Byzantine material south of bedrock Scarp G.11:10.

Stratum VIII: Byzantine (ca. A.D. 450-614)

Description: Soil Layer G.11:27 was a thin fill of earth which lay between the stones of Wall G.11:9. The matrix consisted of granular brown soil mixed with numerous limestone cobbles which were particularly frequent as fill between the south face of Wall G.11:9 and bedrock Scarp G.11:10.

Wall G.11:9 extended from the east to the west balk and ran parallel to the north balk at a distance of 1.40 m. from it. It continued into both those balks and ranged from 0.85 m. to 0.43 m. wide. Along its north face several layers had accumulated and along its south face it ran parallel and adjacent to bedrock Scarp G.11:10, a vertical bank of limestone. At maximum preservation at the east balk, five courses of stones were extant. Due to variation in

the size of the stones the number of courses was not consistent but at no point was the wall more than one row wide. Towards the central portion of the wall the average number of surviving courses was three. The stones were of limestone and varied in shape from cut blocks whose average measurement was 0.50 m. x 0.40 m. to an uncut cyclopean boulder which was considerably larger and spanned the same vertical extent as four or five courses of stones elsewhere along the wall. The stones of the founding course had been set unevenly at different levels. The eastern portion had been founded upon soil Layer G.11:25b and the central and western portions had been set upon *terra rossa* soil Layer G.11:23c. The top levels ranged from 885.49 m. to 885.12 m. and the average bottom level was 884.30 m.

Soil Layer G.11:25b was a localized patch of loose granular brown soil upon which the eastern portion of Wall G.11:9 had been set. Since it was only partially excavated, precise measurements are not available. This layer met foundation Trench G.11:23c and lay upon bedrock Scarp G.11:10 between Wall G.11:9 and the north balk. To the south it extended beneath Wall G.11:9 and to the east it was cut by foundation Trench G.11:25a. The earth matrix consisted of compacted *terra rossa* soil mixed with pebbles of limestone and *huwwar*. The bottom level was 883.59 m. The average depth was 0.50 m.

A soil layer (G.11:12, 14, and 15) extended across the southern half of the Square between the south balk and bedrock Scarp G.11:10. The earth matrix consisted of very loose granular brown soil mixed with rock rubble. The top level was 884.70 m. and the average depth was 0.75 m.

The dating of loci within this stratum was based upon the latest sherds in the ceramic assemblage which in Loci G.11:15 and 25b were possibly Late Byzantine I.

Interpretation: Wall G.11:9 was founded upon two distinct types of soil deposit, had no foundation trench and no associated surface to promote the conclusion that this was part of a domestic unit. Its irregular construction, including uneven founding levels, its position against bedrock Scarp G.11:10 and its orientation east-west which follows the contours of the *tell* all suggested that it may have been a terrace wall of some sort. The deposition south of the bedrock scarp implied, however, that the bulk of the debris filled up against the scarp during Ayyūbid/Mamlūk period. However, this may have been an extensive retainer wall in which case it may have served its purpose more directly elsewhere.

Soil Layer G.11:25b may have been a localized accumulation of destruction debris before it was incorporated into the foundation of Wall G.11:9.

Terra rossa soil Layer G.11:23c accumulated upon bedrock

and though not devoid of cultural remains it did not appear to have any cultural function until Wall G.11:9 was founded upon it.

The soil layer (Loci G.11:12, 14, and 15) south of the plunging bedrock Scarp G.11:10 was in all physical respects identical to the Ayyūbid/Mamlūk soil layers which lay over it, but in it a shaft from Ayyūbid/Mamlūk to Byzantine and Iron Age pottery occurred. This unstratified destruction debris appears to have accumulated through the erosion downhill of collapsed architectural features. Although this may have been a steady process, the pottery reflects principally two periods: Ayyūbid/Mamlūk and Byzantine, which in turn reflect the dominant occupation periods on this part of the *tell*.

AREA G.16

Area G.16, a sounding, was located on a steep slope near the base of the east side of Tell Ḥesbân overlooking the Madaba Road. The Square measured 4.00 m. east to west x 2.00 m. north to south and was opened for the purpose of investigating the sequence of occupation evidence on this slope. In previous seasons it had not been excavated because of problems of land ownership. Excavation was carried out from 14 July to 6 August.

Strata II-III: Mamlūk (ca. A.D. 1260-1456)

Description: Soil Layer G.16:1 lay above soil Layer G.16:7b, 8, 9, and 11 and *terra rossa* soil Layer G.16:7a and extended throughout the Square. The earth matrix consisted of compacted gray-brown granular soil mixed with pebbles and cobbles of limestone and flint. A few localized patches of *terra rossa* soil were present. Very little occupational debris was included in the earth matrix. The average depth was 0.75 m.

This layer was dated to the Ayyūbid/Mamlūk period on the basis of the latest sherds in the ceramic assemblage.

Interpretation: This massive but homogeneous layer was the accumulation of soil which had eroded down the *tell* during the Ayyūbid/Mamlūk period. This deposit was free of architectural or destruction debris, indicating that the upper slope of the east side of the *tell* may not have been occupied in the Ayyūbid/Mamlūk period.

Stratum VII: Late Byzantine (ca. A.D. 614-661)

Description: The Late Byzantine Stratum VII in Area G.16 comprised several soil layers and two walls between which a deep probe was excavated.

Terra rossa soil Layer G.16:7a lay over Locus G.16:7b throughout the Square except to the east, where it met soil Layer G.16:6. The earth matrix consisted of compacted *terra rossa* soil mixed with pebbles of limestone and flint. The average depth of excavation was 0.10 m.

A soil layer (G.16:7b, 8, 9, and 11) lay over soil Layers G.16:12 and 17 as well as Walls G.16:10 and 13 and covered the entire Square. This consisted of yellowish brown granular soil. It was lightly compacted and mixed with pebbles and cobbles of flint and limestone toward the top but was well compacted in the bottom portion where it was mixed with rock rubble, including limestone boulders. Depth ranged from 0.64-0.70 m.

Terra rossa soil Layer G.16:12 lay over soil Layer G.16:14 and the east portion of the top of Wall G.16:13. The earth matrix consisted of tightly compacted *terra rossa* soil free of inclusions. The top level was 864.40 m. and the bottom level was 864.15 m. The average depth was 0.25 m.

Soil Layer G.16:14 covered the Square from the east face of Wall G.16:13 to the east balk. The earth matrix consisted of lightly compacted brown soil mixed with rock rubble, including pebbles and cobbles of limestone and small patches of *terra rossa* soil. The lower portion of the layer contained a greater percentage of *terra rossa* soil. The average depth was 0.20 m.

Wall G.16:13, parallel to Wall G.16:10, extended from the north to the south balks and lay parallel to the east balk 1.40 m. from it. Its width ranged from 0.50 to 1.00 m. Though of rubble construction, the wall was two courses high and two rows wide. It consisted of large boulders and cobbles of both limestone and flint which were founded upon *terra rossa* soil Layer G.16:15, 17, and 18. The top level was 864.46 m. and the bottom level was 863.98 m.

Wall G.16:10 extended from the north to the south balk and lay parallel to the west balk 0.30 m. from it. The wall, one course high and one row (0.50 m.) wide, consisted of five uncut limestone boulders which had been laid side by side upon the *terra rossa* soil layer G.16:15, 17, and 18. The top level was 864.46 m. and the bottom level was 863.98 m.

Terra rossa soil Layer G.16:15, 17, and 18 extended both east of Wall G.16:13 the the east balk and between and beneath Walls G.16:10 and 13 where it lay over cobble Layer G.16:19 and 20. The earth matrix consisted of tightly compacted *terra rossa* soil mixed with pebbles and a few small cobbles of limestone and *huwuar*. The average depth of this layer was 0.45 m.

The earth matrix of cobble Layer G.16:19 and 20 consisted of approximately 70 percent small to medium-sized limestone cobbles mixed with decomposed limestone and loose granular yellowish brown soil. Numerous air pockets where the soft soil had subsided were scattered throughout.

The loci discussed above were dated to the Late Byzantine Stratum VII on the basis of the latest sherds in their ceramic assemblages.

Interpretation: Cobble Layer G.16:19 and 20 was a deep fill of destruction debris for which the process of accumulation was accomplished without the formation of any internal stratigraphy.

No integral relationships between this debris and any other features were exhibited from its limited exposure within the Area. The nature of this destruction debris does indicate however that a subphase of occupation within this stratum may be identified if pursued further. The *terra rossa* soil layer G.16:15, 17 and 18) which had formed over this fill also indicated that no direct occupation existed here at the time that it was formed. Walls G.16:10 and 13 were constructed on the *terra rossa* soil superficially, without foundation trenches. No associated floors or surfaces were identified. The relationship of these walls to one another was vague. They were found at the same level, in a similar manner, and upon the same soil horizon, all of which leaves open the possibility that they were used either as terrace walls (possibly to retain eroding soil) or property markers, but conclusive evidence is lacking. The thick layer which was deposited over the walls appears to have accumulated as the result of soil eroding down the *tell*. Also subsequent to the use of the walls and the abandonment of this part of the *tell*, was the formation of *terra rossa* soil Layers G.16:12 and 7A over Wall G.16:13 and throughout the Square. In summary, the evidence suggested accumulations by natural processes of erosion with some possible efforts toward erosion control.

AREA G.17

Area G.17 was located on nearly level ground at the base of Tell Heshbân below its eastern slope. This Square was a small 2.00 m. square probe opened in order to detect a reported mosaic floor which had been discovered by a villager who then refilled the post hole which he had been digging. The second objective was to investigate this reported mosaic's relationship to any datable architectural feature and determine what type of structure had been involved. This Square was excavated from 21 July to 28 July.

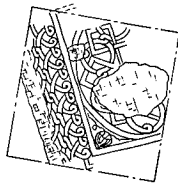

G.17 MOSAIC FLOOR
SCALE
0 40 80 120 160 2.00 M.

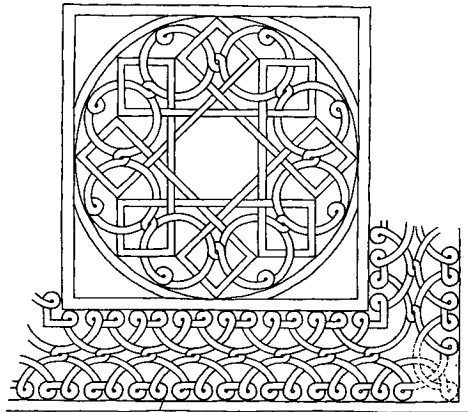

RECONSTRUCTION of DESIGN
0 .50 1.00 M.

HESHBON 76
AREA G SQ. 17
DRAWN JUNE 1977
BY BERT DEVRIES

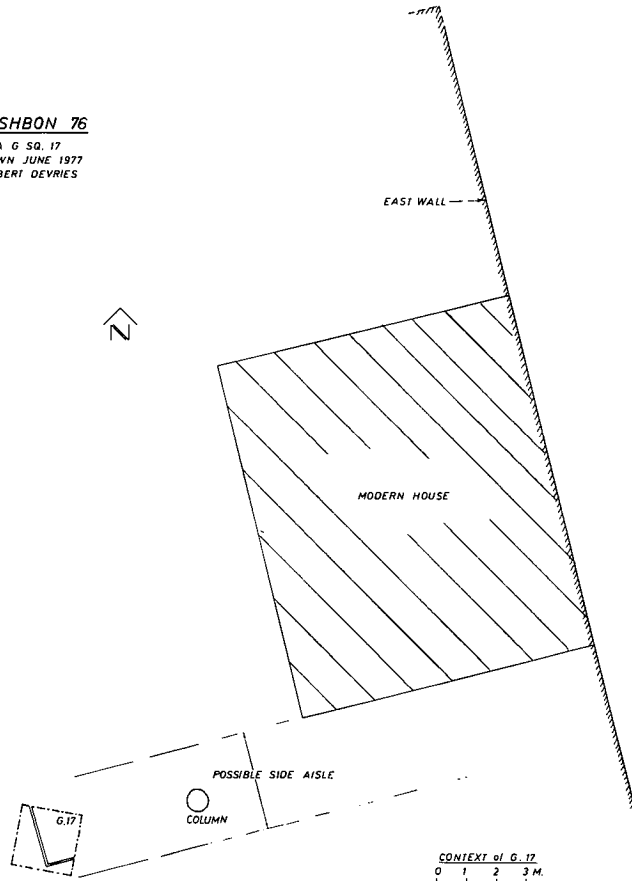

Fig. 16. Plan of G.17 mosaic floor, including its context and reconstruction.

Stratum I: Modern (1870-)

Description: This period was represented by one pit (G.17:1), which was located in the southeast corner of the Square where it touched both the east and south balks and lay over mosaic Floor G.17:2. It measured 0.50 m. east to west and 0.95 m. north to south and was 0.75 m. deep. The earth matrix consisted of granular brown soil mixed with plaster, pebbles of limestone, tesserae and modern trash including a shoe and several metal cans. The top level was 800.15 m. and the bottom level was 799.39 m.

Interpretation: Pit G.17:1 appears to have been a post hole dug within the last decade and back-filled with modern trash.

Stratum II: Late Mamlūk (ca. A.D. 1400-1456)

This period was represented by topsoil and a layer of soil directly beneath it.

Description: Soil Layer G.17:3 was located across the entire Square except in the southeast corner where it was cut by Pit G.17:1. It measured an average of 0.20 m. deep. The matrix consisted of dry gray top soil in the upper portion and *terra rossa* soil mixed with patches of compacted brown soil, patches of loose brown soil, and small cobbles of limestone. The top levels ranged from 800.41 m. to 800.19 m. and the bottom levels ranged from 800.07 m. to 799.92 m. The dating of this locus to Stratum II was based upon the latest sherds in the ceramic assemblage.

Interpretation: This layer represented postoccupational deposition of soil, possibly from the erosion of sediment down the east slope of the *tell*. There was no direct Late Mamlūk occupation at this location, but Ayyūbid/Mamlūk pottery attested that the soil accumulation did occur during this period or later.

Stratum VII: Late Byzantine (A.D. 614-661) or Stratum VIII: Byzantine (ca. A.D. 450-614)

This stratum consisted of a Byzantine accumulation including different soil layers deposited over a mosaic which was located but not lifted.

Description: A soil layer (G.17:4, 5, 6, and 9) was located over the entire Square except in the southeast corner. It lay over mosaic Floor G.17:2 and soil Layers G.17:7 and 8. It was 0.60 m. deep. In the southeast corner of the Square it was cut by Pit G.17:1. The earth matrix consisted of compacted brown soil mixed with cobbles, pebbles and limestone. The top level was 800.00 m. and the bottom level was 799.39 m.

Soil Layer G.17:8 was located in the northwest corner of the Square and lay over mosaic Floor G.17:2. It measured 0.95 m. east to west x 0.80 m. north to south and was 0.27 m. deep. To the south it met soil Layer G.17:9 and 6, and to the east it met soil Layer G.17:7. The earth matrix consisted of moderately compacted reddish-brown soil mixed with cobbles and pebbles of limestone. The top level was 799.61 m. and the bottom level was 799.34 m.

Soil Layer G.17:7 was located in the northeast corner of the Square and lay over mosaic Floor G.17:2. It measured 0.89 m. east to west x 0.75 m. north to south and was 0.30 m. deep. To the west it met soil Loci G.17:6, 9, and 8. On the south it was cut by Pit G.17:1. The earth matrix consisted of rock rubble including small limestone cobbles and boulders mixed with loose brown soil. Of the boulders four or five had been cut to square shapes measuring on the average 0.40 m. x 0.35 m., and one face of one of these cut blocks had plaster adhering to it. Large pebble-sized fragments of plaster were mixed with the soil. The top level was 799.69 m. and the bottom level was 799.39 m.

Mosaic G.17:2 extended into all four balks. The original floor had been laid with small multicolored tesserae set in a geometric pattern. Several patches of repair were set with larger, plain white tesserae. In a few places the mosaic had broken away altogether. The top level was 799.39 m.

These loci were dated to within the scope of Stratum VII and Stratum VIII on the basis of the latest sherds in the ceramic repertoire.

Interpretation: Soil Layer G.17:7 appeared to have been the result of architectural collapse, possibly from the ruin of a structure associated with the mosaic floor. The other sediment and debris layers seemed to be naturally accumulated subsequent to the abandonment of the building.

Mosaic Floor G.17:2 clearly extended into all of the balks of the Area and probably functioned as the floor of a church or some other structure. No architectural features associated with the mosaic were intercepted within the Area. The date of the mosaic remained tentative as it was not lifted and pottery from the layer above indicated that either a Stratum VII or Stratum VIII date for the material was possible. Therefore mosaic Floor G.17:2 could be dated to either of these Strata or even earlier.

AREA G.18

Area G.18 was located next to a building known to the villagers as the "Qasr," a turn-of-the-century structure which stands in a central position in the modern village of Ḥesbân. The objective was to investigate and date a wall upon which the northwestern corner of the Qasr had been built. An L-shaped trench was

oriented so as to intercept on its short axis the foundation trench of the earlier wall (G.18:1) and on its long axis another wall (G.18:2) perpendicular to the first wall. The trench measured 6.00 m. north to south x 1.00 m. east to west on its long axis and 2.25 m. east to west x 1.00 m. north to south on its short axis. Modern drainage pipes extending through the northern portion of the trench halted plans for excavation north of Wall G.18:2. Excavation south of Wall G.18:2 was terminated prematurely when modern burials were discovered. Consequently the investigation of Wall G.18:2 was suspended.

Because of the descriptive problems created by an L-shaped trench, three sectors were identified to facilitate clarity in recording. Sector I included the short axis from Wall G.18:1 to the junction with the long axis and measured 1.25 m. long x 1.00 m. wide. Sector II included the southern portion of the long axis adjacent to sector I and measured 1.00 m. square. Sector III included the portion of the long axis which lay between Wall G.18:2 and sector II, and measured 1.00 m. wide x 1.65 m. long.

At the time that excavation was initiated this trench spanned a path, used by pedestrians and shepherds, which passed between the Qasr and the village mosque. Excavation was carried out from 30 July to 6 August.

Strata II-III: Mamlūk (ca. A.D. 1260-1456)

Description: Soil Layer G.18:3 extended across all of sectors I, II, and III and lay over soil Layer G.18:4, foundation Trench G.18:7, soil Layer G.18:6, foundation Trench G.18:15, and cist Burial G.18:5. The earth matrix included top soil mixed with cobbles and pebbles of limestone, tesserae, and vegetation. In the lower portion of the locus in sectors II and III the matrix consisted of compacted gray soil and in sector I a patch of compacted *terra rossa* soil embedded in gray soil, localized patches of red-brown clay, *huwwar*, and charcoal. This compacted matrix was mixed with chips and pebbles of limestone, tesserae, and one human bone. The top level was 873.39 m. and the bottom levels ranged from 873.14 m. to 872.95 m.

Soil Layer G.18:4 extended across sector III and into the northern portion of sector II. It lay over cist Burials G.18:5 and 9. The earth matrix consisted of loose, light brown soil mixed with pebbles, cobbles and boulders of limestone, and air pockets where the soft soil had subsided. The average depth was 0.14 m.

Cist Burial G.18:9 (partially excavated) lay in sector III adjacent to cist Burial G.18:5. The exterior measured 1.00 m. east to west x 0.40 m. north to south and it extended into the east and west balks. Limestone cobbles, one course high and one row wide, formed the parallel north and south walls of the cist. The matrix consisted of loose, pale brown soil mixed with chips, pebbles, and cobbles of limestone. The top level was 872.87 m.

Foundation Trench G.18:7 was located between the row of cobbles forming the south wall of cist Burial G.18:5 and the west balk. It measured 1.00 m. east to west x 0.45 m. south to north and touched the west and south balks. On the north it met cist Burial G.18:5 and soil Layer G.18:4. It lay over soil Layer G.18:6. The matrix consisted of a pale brown soil mixed with pebbles and cobbles of limestone and with charcoal. From this trench came an ostrakon (object no. 2951) which joined to the one from the Late Byzantine Layer G.18:6 below. The top level was 872.96 m. and the bottom level ranged from 872.96 m. to 872.60 m. The average depth where it met the south balk was 0.10 m. The average depth where it dipped downward to meet the burial was 0.30 m.

Cist Burial G.18:5, an oval pit ringed with stone, was located in sectors II and III. The exterior of the structure measured 1.00 m. east to west x 0.85 m. north to south. The interior measured 1.00 m. east to west x 0.52 m. north to south and it extended into both the east and west balks of sectors II and III. On the south it met foundation Trench G.18:13, soil Layer G.18:12, Surface G.18:8, and soil Layer G.18:6. The limestone cobbles which formed the cist averaged 0.25 m. x 0.15 m. x 0.20 m. and were set vertically side by side (one course high, one row wide) in two parallel lines extending east to west. The sediment and debris within the cist consisted of loose, pale brown soil mixed with chips, pebbles, and cobbles of limestone, and fragments of human and other bone. The latter were analyzed in the field by Robert Little as follows. The bones articulated within the cist burial comprised left femur, left fibula, left foot bones, left ulna, and left tibia, all probably of an adult female. Pelvic bones protruding from the west balk suggested that a complete articulated skeleton lay there. The bones were aligned from east to west with the head towards the west. A skull fragment and ulna of a child less than 10 years old indicated that this was a multiple burial. The top level was 873.00 m. and the bottom level (arbitrary) was 872.56 m.

Interpretation: The Ayyūbid/Mamlūk strata were represented primarily by two cist burials. It appears that an Arab cemetery had been intercepted, for the pottery belonged to the Ayyūbid/Mamlūk period. These burials were without elaborate tomb structures or grave goods and seemed therefore to have been burials of average citizens. The presence of what appeared to be clusters of capping stones extending from area G.18 southwest for about 20.00 m. until meeting the modern cemetery indicated the scope of the Ayyūbid/Mamlūk cemetery.

The ostrakon found in foundation Trench G.18:7 appeared to

have originally come from the same deposit as the ostrakon from Layer G.18:6, for that layer had been cut into when cist Burial G.18:5 was constructed. This mixed the Late Byzantine wares with the Ayyübid/Mamlük wares.

Soil Layers G.18:3 and 4 accumulated after the burials, and deposition continued to the present.

Stratum VII: Late Byzantine (ca. A.D. 614-661)

Description: Soil Layer G.18.6 was located throughout sector I and between foundation Trench G.18:7 and the south balk. It lay over both soil Layer G.18:11 and Surface G.18:8. On the east it was cut by foundation Trench G.18:15; on the northwest it was cut by cist Burial G.18:5; and to the southwest it was cut by foundation Trench G.18:7 and reached the west balk. The matrix consisted of compacted granular brown soil and clay mixed with chips, pebbles, and cobbles of limestone. This locus also contained an ostrakon (object no. 2952). The top levels ranged from 872.85 m. to 872.77 m. The depth varied as this layer sloped downward and lensed thinly towards the west. The average depth was from 0.35 m. to 0.10 m. towards the west.

Soil Layer G.18:11 was located in sector II where it extended from foundation Trench G.18:7 to the south balk. To the east it lensed into Layer G.18:6 and to the north it was cut by foundation Trench G.18:7. The matrix consisted of lightly compacted pale brown soil mixed with limestone pebbles and charcoal flecks. The average depth was 0.05 m.

Surface G.18:8 was located in sector I where it lay over soil Layer G.18:12. It measured 1.25 m. east to west x 1.00 m. north to south and touched both the north and west balks. To the northeast it was cut by foundation Trench G.18:15 and to the southeast it lensed out and was met by soil Layer G.18:6, to the northwest it was cut by cist Burial G.18:5 and to the southwest it lensed out and was met by soil Layer G.18:6. The matrix consisted of compacted light gray soil mixed with pebbles of limestone and fragments of charcoal. The average depth was 0.50 m.

Soil Layer G.18:12 was located in sector I where it lay over Surface G.18:13. To the east it was cut by foundation Trench G.18:15 and to the west it was cut by cist Burial G.18:5. The matrix consisted of compacted brown soil mixed with pebbles of limestone. The average depth was 0.15 m.

Surface G.18:13 lay over soil Layer G.18:14. To the east it was cut by foundation Trench G.18:15, to the southwest it lensed out and met soil Layer G.18:12, and to the northwest it was cut by cist Burial G.18:5. The matrix consisted of compacted white plaster mixed with minor inclusions of crushed pottery, sand, and dung. The average depth was 0.10 m.

Foundation Trench G.18:15 lay over soil Layer G.18:14. On the east it was adjacent to Wall G.18:1 and on the west it cut Surface G.18:13, soil Layer G.18:12, Surface G.18:8, and soil Layer G.18:6. The earth matrix consisted of lightly compacted red-brown soil mixed with patches of *terra rossa* soil, patches of gray clay and rock rubble, including pebbles and cobbles of flint

and limestone. The top level was 873.03 m. and the bottom level was 872.66 m. The average depth was 0.35 m.

Wall G.18:1, which had been built on a north-south axis, extended perpendicular to sector I and formed the east balk of that sector. It was adjacent to foundation Trench G.18:15 to the west. Where it appeared in the east balk it consisted of four limestone blocks cut roughly to square shapes and vertically dressed. The spaces between them were filled with earth and cobbles. Two surviving courses appeared in the east balk but elsewhere along the wall it was evident that the maximum preservation above ground surface was four courses high, one row wide. The top level was 873.40 m. and the bottom level was 872.66 m. The depth was 0.75 m.

Soil Layer G.18:14 was located in sector I where it extended 1.25 m. east from Wall G.18:1 and touched the north, south, and east balks. The earth matrix consisted of lightly compacted pale brown soil mixed with limestone chips, pebbles, and a few cobbles. The top level was 872.66 m. and the bottom levels (arbitrary) ranged from 872.61 m. to 872.56 m.

These loci were dated to the Late Byzantine stratum on the basis of the latest sherds in the ceramic assemblage.

Interpretation: The Late Byzantine stratum was largely represented by a series of alternating surfaces and soil deposits. Plaster and soil Surfaces G.18:13 and 8 may have been refloorings within the same architectural unit. The layers G.18:14, 12, and 6 represented debris which could have accumulated in periods of nonoccupation. Though some occupational debris was mixed with the earth it did not constitute a large percentage. Therefore it seemed unlikely that intensive domestic activities were carried out here. There was no architectural context within which to interpret these surfaces. Although two subphases may have been represented here there was no clear evidence either way.

The construction of Wall G.18:1 does appear to represent a subphase, for this was the latest feature of the phase, and it was clear that with its construction the surfaces adjacent on the west had ceased to function, and layer G.18:6 had accumulated later. There was no floor with which Wall G.18:1 could be associated, which indicated that if the wall was part of a structure the interior of that structure lay east of the wall.

AREA G.12

B. MICHAEL BLAINE
Glendale, California

The location of G.12 was southwest of the *tell* on a small ridge or saddle of land which lay between the *tell* and the present village of Ḥesbân. The Square was laid out at the foot of the *tell* partly in a depression which appeared to be surrounded by traces of ancient walls. Emphasis was placed on stratigraphic identification and sequence.

Initially the Square was set 3.00 m. x 3.00 m. but because of the discovery of a large cistern in the northeast corner during the early stages of excavation, the Square was extended 1.00 m. northwards to facilitate operations.

Stratum I: Modern (A.D. 1870-present)

G.12:1 was a layer of topsoil containing occupational debris attributed to the modern settlement of Ḥesbân.

Stratum III: Early Mamlūk (A.D. 1260-1400)

Stratum III was represented by somewhat inferior construction. Wall G.12:2 was 1.30 m. wide and passed through the center of the Square north to south. Foundation Trench G.12:7 was dug against the east face of Wall G.12:2 to allow rebuilding or repair of the wall. Large field stones were used, and these contrasted with the partially dressed stones of the earlier phase of wall construction. Locus G.12:3 was a 6.00 m. deep, square-shafted cistern located in the northeast corner of the Square. Sherds from the upper soil layers inside the cistern indicated that the cistern had been abandoned through the Early Mamlūk period before it was sealed.

A compacted clay surface (G.12:6) sloped downward toward the north and the east at 10°, and served as a catchment for

ground surface water which was directed to a break in the fractured millstone forming the mouth of the cistern. The break in the millstone had been held open by fist-sized stones to allow ground surface water to run into the cistern. Ceramic data from this prepared surface, and from the soil layers (G.12:4, 6, and 9) around the mouth of Cistern G.12:3 indicated that the millstone was set in place in the Early Mamlük period. This modification was contemporary with Phase *b* of Wall G.12:2 construction.

Stratum VI: Umayyad (A.D. 661-750)

A gap in occupation was indicated between Strata III and VI. Stratum VI (soil Layer G.12:13) was the continuation of accumulation of debris in a pit which had been dug in Stratum VII. This shallow pit was located in the southeast corner of the Square.

Stratum VII: Late Byzantine (A.D. 614-661)

Stratum VII soil Layers G.12:14 and 15 contained ceramic evidence which dated the early use of the pit as Late Byzantine. This shallow pit had been dug into Early Byzantine soil layers. The specific purpose for which the pit was dug was not indicated by materials from these loci. Nor did the pit appear to have any particular relationship to structures within the Square.

Strata IX-XIV: Early Byzantine I-III (A.D. 324-450)



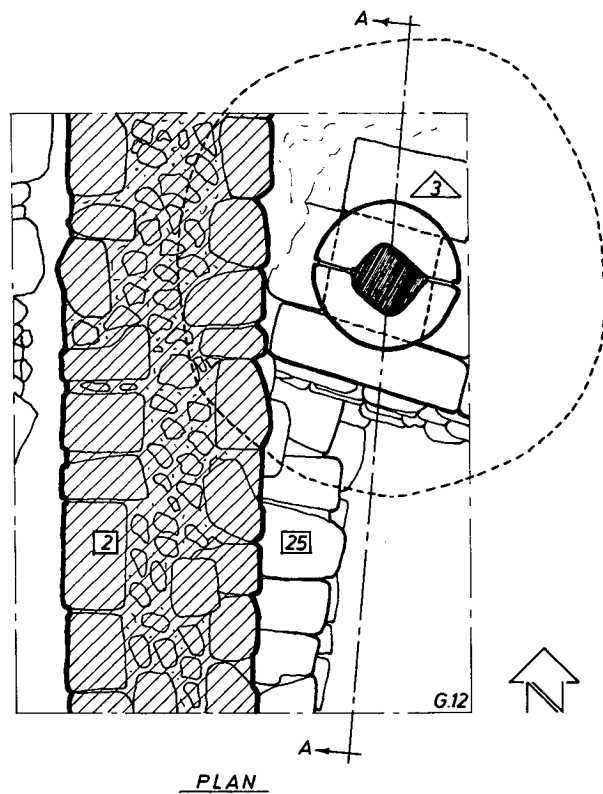

Strata IX-XIV materials were characterized by construction. Wall G.12:2 was founded on top of an earlier wall (G.12:25). However, it was not a rebuild of this earlier wall nor oriented precisely the same as the earlier wall. Materials for construction of Wall G.12:2 were collected in the vicinity of the *tell*. Most had been partially dressed and had at least one smooth face. However, they were not fitted closely together as they would have been if prepared exclusively for this project. Small stones had been used for chinking. One stone had been marginally drafted. Soil Layers G.12:17, 18, 19, 20, 21, and 23 had been filled in against the east face of Wall G.12:2 and represented a



HESHBON 1976

DRAWN JULY 8 1976 BY
BERT DEVRIES, DAVID PIPER, HENRY
KUHLMAN & DANIEL SALZMANN

AREA G SQUARE 12

CISTERN , WALLS  & 
0 .40 .80 1.20 1.60 2.00 M.

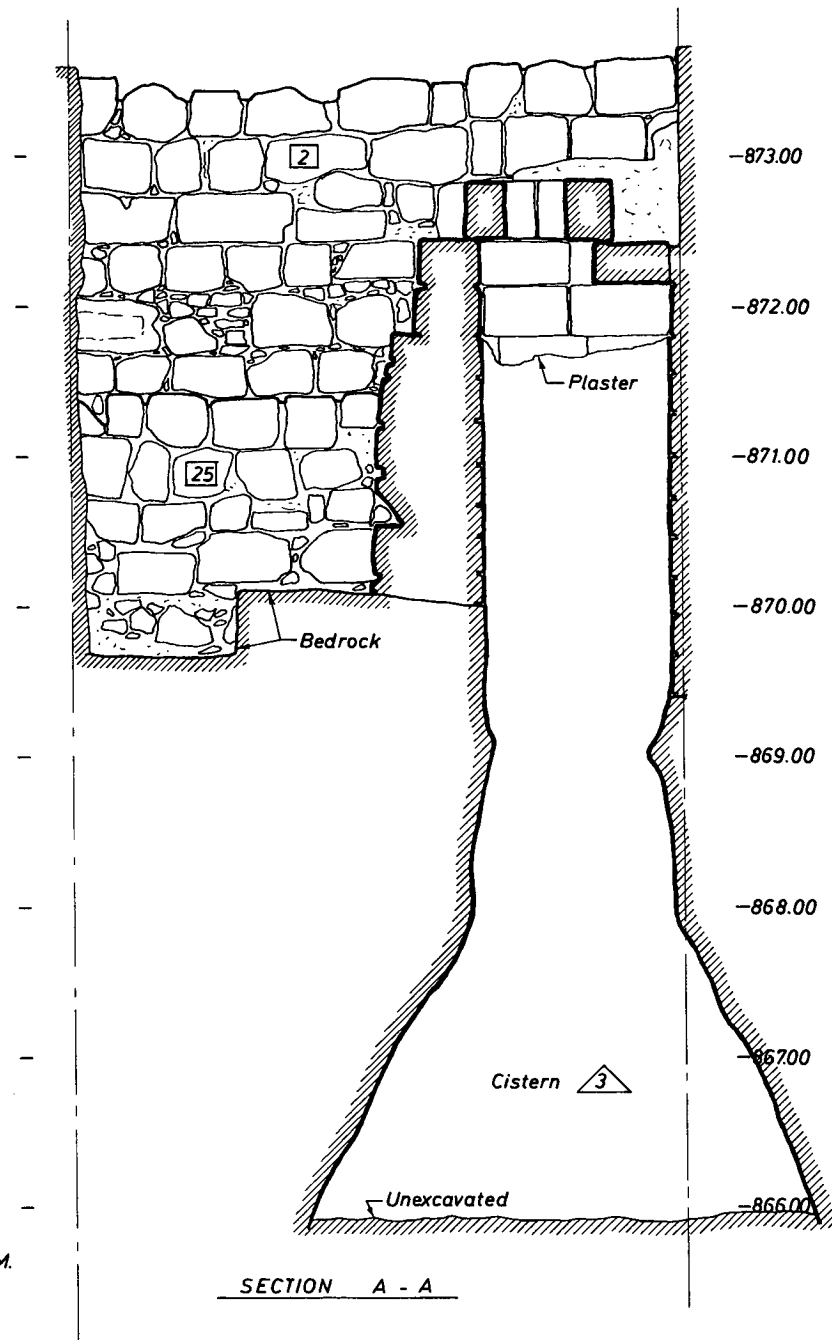

Fig. 17. Plan of G.12 with section of Cistern G.12:3.

backfilled cut into the soil layers of Strata VI and VII for a foundation trench for the construction of Wall G.12:2.

Other construction which occurred during this period was the extension upward of the shaft of Cistern G.12:3. The lower five courses of stone in the south segment of the shaft walls were constructed with a vertical exterior face. The level of the fifth course from the bottom would have corresponded to the level of the ground surface used in the Late Roman period (soil Layer G.12:16). Sherds from soil Layer G.12:12 indicated that a foundation trench had been cut through the Late Roman and Early Roman soil layers of Strata XV and XVII-XVIII against the south wall of the shaft in order to extend the cistern shaft upward in the Early Byzantine period. The thickness of the shaft's south wall up to the 872.00 m. level was approximately 0.75 m. This indicated shaft walls constructed two rows thick. The next course of stone above this level (6th course from the bottom) was set in toward the north and narrowed the shaft wall to approximately 0.30 m. The upper portion of the cistern shaft wall (three courses) was attributed to the Early Byzantine stratum.

The construction of Wall G.12:2 was related to this phase of cistern modification. A large stone in Wall G.12:2 was deliberately offset during construction so that its north end was made to abut against the next-to-the-top course of the shaft's south wall. A fill of large rocks and soil was placed against this extension of the cistern shaft and then sealed over by the thin (ca. 0.04 m. deep) *huwwar* Surface G.12:11 which ran about 0.40 m. wide against the cistern shaft's south wall between Wall G.12:2 and the east balk. The *huwwar* surface just covered the top of the offset stone in Wall G.12:2. Ceramic material dated this *huwwar* surface as Byzantine, and comprised the ground surface connected with the use of the cistern in the Early Byzantine period. The interior faces of the cistern shaft had been plastered, but an examination of plaster samples failed to provide any datable evidence. Because the plaster of the interior of the cistern shaft

reached up to the uppermost course of stone under the top, the cantilevered course, it was reasonable to include the most recent plastering of the interior of the cistern shaft as a part of the Early Byzantine cistern modifications.

Stratum XV: Late Roman II-IV (A.D. 193-324)

Stratum XV was represented by Wall G.12:25, which was founded on bedrock and extended from the south balk to the shaft of Cistern G.12:3. Because the west faces of Walls G.12:2 and G.12:25 were not exposed, the precise width of Wall G.12:25 is not known. The top surviving course of Wall G.12:25 was probably not the original top at the time of its construction because the present top course lay below the Late Roman soil layers. The original height of Wall G.12:25 was not apparent nor was the reason for its construction. It may have formed part of an adjoining domestic structure. It should also be noted that the interior face of the west wall of the Cistern G.12:3 shaft was not aligned with Wall 25 (see Plate XV:A). Because a stone of the top surviving course of Wall G.12:25 formed an integral part of the south wall of the shaft of Cistern G.12:3 they must have been of contemporary construction. This indicated the upward extension of two courses of the cistern shaft south wall in the Late Roman period. A foundation trench for the construction of Wall G.12:25 had been cut through the soil layers of Strata XVII-XVIII, XX, and XXII. Backfill in this trench (comprising Loci 28, 30, 32, 34a, 35a, 36a, 37a, and 38a) was dated Late Roman II-IV from ceramic evidence, as were also soil Layers 16, 22, and 24.

Stratum XVII-XVIII: Early Roman II-IV (31 B.C. - A.D. 135)

Evidence for this stratum came from Locus 27, a soil layer 0.25 m. thick of debris which contained some animal bone fragments as well as sherds.

Stratum XX: Late Hellenistic (198-63 B.C.)

Stratum XX was represented by the 0.95 m. deep soil Layers G.12:29, 31, 33, 34b and c, and 35b and c.

A 0.10 m. wide strip of soil adjacent to the south shaft wall of Cistern G.12:3 was excavated separately from the soil layers further south to check for possible foundation trenching. The ceramic evidence from this 0.10 m. wide strip was dated consistently the same as for the soil loci adjacent to the south. Visual examination also showed that these Late Hellenistic soil layers sealed against exterior faces of the lower courses of the Cistern G.12:3 shaft south wall, indicating that the lower courses of the cistern shaft were constructed sometime prior to the Late Hellenistic period. The bottom of the lowest Late Hellenistic soil layer (G.12:35) touched and lay over the top of a bedrock bench adjacent to the Cistern G.12:3 shaft which bench had been left from apparent quarrying.

Stratum XXII: Iron II/Persian (800-500 B.C.)

A gap in occupation was indicated between Stratum XX and the next lower materials of Stratum XXII. Stratum XXII was attested by 0.40 m. of soil layers and rock fill (G.12:36b and 37b) which yielded datable Iron II/Persian sherds. These soil layers filled in the quarried sector of bedrock south of the bench and east of the foundation trench for construction of Wall G.12:25. The south wall of the shaft of Cistern G.12:3 was not founded on the bedrock bench but continued on downward. The bedrock bench had been carefully cut to allow for stability of the shaft wall. How far the stone courses of the shaft continued down could only be determined either by removal of the plaster from the inside faces of the shaft or by dismantling the shaft walls.

Cistern G.12:3

The evidence indicated that this cistern was created some time prior to the Late Hellenistic period and then kept in use through-

out the cited stages of occupation until it was closed in the Ayyūbid-Mamlūk period. To indicate an ethnographic observation, it should be noted that even now in modern times Arif, the man who lived in the house closest to the cistern, wanted to put it into use again as a watering place for his sheep. In the past, as the level of the ground surface had been raised by the accumulation of debris, the walls of the cistern shaft were extended upward. The shaft for Cistern G.12:3 therefore represented construction by stages over a period of at least 1400 years. If Arif is to use the cistern, he will have to raise the level of the cistern shaft to the level of the present ground surface to accomplish his intent, or build a stair or other access to the level of its surviving shaft mouth.

AREA G.14

JOHN LAWLOR
Baptist Bible College
Clarks Summit, Pennsylvania

In the sector just north of Tell Ḥesbân the remains of what appeared to be a Byzantine church came to the attention of the staff. Certain architectural features were visible above ground surface;¹ these gave an initial clue to the nature of the structure. Consequently, a sounding was carried out during the last four weeks of the season. Three primary objectives were set for this project: (1) to establish a founding date for the structure; (2) to establish the relationship between Walls 3 and 4 and identify the structure; and (3) to check the stratigraphy of this sector with the stratigraphy of the *tell*. The initial 3.00 m. x 2.00 m. probe (gradually expanded to 6.00 m. x 4.00 m.), was laid out in such a manner as to attempt to accomplish all three objectives. By the end of the season all three objectives had been achieved.

The soil layers, architectural features, and other installations corresponded well with the stratigraphic framework for the whole of Tell Ḥesbân. The data will be presented in top-to-bottom (late-to-early) sequence, corresponding to that stratigraphic framework.

Strata III-IV: Ayyūbid/Early Mamlūk (A.D. 1200-1400)

After the removal of the modern wall, rock tumble, and debris accumulated "inside" the apse (west of Wall 4), a layer of topsoil, Locus 2, was encountered. This averaged 0.10 m. in depth. Locus 2 yielded a span of sherds from Ayyūbid/Mamlūk to Byzantine, though they were predominantly Ayyūbid/Mamlūk. Fragments of four dif-

¹ These architectural features included an apsidal wall, identified as Wall 4 throughout this report; a north-south wall, identified as Wall 3 throughout this report, which lay immediately east of Wall 4; column bases; one unbroken column drum in a horizontal position; and tesserae scattered over the region.

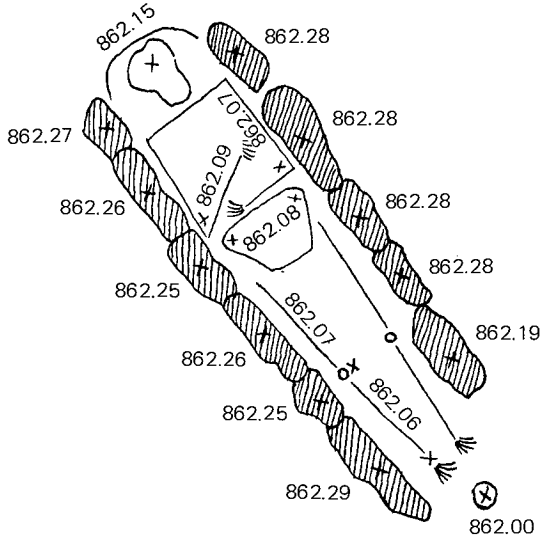

Fig. 18. Field sketch of cist Burial G.14:10 (scale: 1:25).

ferent skeletons were taken from Locus 2: one possibly male adult; one female adult; one infant, 1-2 years of age; one infant, less than one year old. The pottery taken from the context of these fragmented remains dated them very clearly to the Late Ayyūbid period (A.D. 1200-1260) or Early Mamlūk period (A.D. 1260-1400).

In the western two-thirds of the Square (west of Wall 4), Locus 8 lay immediately below Locus 2. Locus 8 contained the first fully articulated skeleton in an extended position. This burial differed from the other articulated burials in that it was not a cist burial. The orientation of the skeleton was head-to-west. The skeleton was that of a female, fifty years or older, whose height had been about 1.60 m. One of the distinguishing features of this skeleton was its mandible. "The mandible was singular in that all teeth had been lost early in life and a solid ridge of bone had formed with considerable lingual lipping."² Fragments of five other skeletons were also found in Locus 8.

At the western end of the probe was a series of cist burials, Loci 10, 13, 15, 17, 18, and 32. These cists were constructed of rough field stones set on edge in the general shape of an Egyptian mummy case; broader (ca. 0.40 m.) from the waist up, tapering slightly to the ankles (ca. 0.25-0.30 m.), with an average length of 1.80-2.00 m. These dimensions varied from one cist to another.³ An additional feature relating to these installations is the fact that there were three "layers" of them. The upper layer, from north to south, was arranged in the following order: Loci 13, 10, 15. Locus 17 was directly under 15 in the southwest quadrant of the Square and Locus 18 was directly under 13 in the northwest quadrant. Locus 32 was under Locus 17.

Four of these cists contained fairly well preserved articulated skeletons in the extended position. The other two contained major portions of skeletons, though not articulated. Fragments of from one to six additional skeletons were found in each of the cists. Locus 10 contained a skeleton of a male aged 40-45 with a probable height of 1.70 m. As the rib cage of this skeleton was being excavated, the arms and hands, folded across the chest, were exposed. It was noticed that a green patina covered the tip of the little finger on the right hand. It was carefully uncovered, revealing a ring on the tip of the right finger.

Locus 13 yielded parts of seven different skeletons. Some fragments belonged to an old male, some to a small young adult female; the

² R. M. Little, anthropologist's field report, in G.14 field notebook.

³ See Fig. 18.

rest were remains of children and infants (one twelve-year-old male, one five-year-old male, one infant approximately one-year-old and two fetuses). It was unclear whether all these were members of the same family, or whether some earlier burials were extensively disturbed by the process of cist construction. A small bronze necklace and bracelet were found in this cist, as well as a small bowl.⁴

Locus 15 contained representative fragments of one old adult and one infant. A fully articulated skeleton was discovered in Locus 17. It was in an extended position. On the basis of tooth wear and many other factors, it was determined that these were the remains of a 30-40 year old male. In addition, fragments of an adult male (possibly 40-50 years old) and one infant or fetus were found in this locus. The pottery suggested that the burials occurred during the Ayyūbid/Mamlūk period.⁵

The next cist encountered, Locus 18, contained parts of three skeletons, two badly fragmented (one 17-25 year-old male and one old male); and the third, roughly articulated, had an estimated height at death of 1.70 m.

The last of these cists, Locus 32, yielded skeletal fragments of three male adults, one child four years old, and one probably premature infant. One of the three adult male skeletons was fairly well articulated. The skull was dislodged from its original position for it was not articulated with the rest of the skeleton. The pottery from this locus pointed to an Ayyūbid/Mamlūk date.

There were certain clearly discernible patterns in these cist burials. The cists themselves were all constructed in much the same manner and were all laid with the same east-west orientation. Each cist contained fragments of more than one skeleton, though not all contained articulated skeletons. In those cases where articulated skeletons were found, the remains all had the same head-to-west, feet-to-east orientation. All of the cists contained Ayyūbid/Mamlūk sherds as well as others dating to earlier periods.

The puzzling question about these burials is how to account for

⁴ This bowl continues to be something of a mystery. The base seemed to have traces of the Early Roman string-cut base; a ribbing around the body of the bowl that resembled Byzantine ribbing, and a ware that might have been either 'Abbāsīd or Ayyūbid. James Sauer suggested that its date was the most recent of these periods, in other words, Ayyūbid/Mamlūk. Of the 89 sherds taken from this locus, 3 were dated to the Ayyūbid/Mamlūk period; the rest were probably Umayyad, Byzantine, Late Roman, and some unidentifiable items.

⁵ Pottery pail 31 was read: 2 Ayyūbid/Mamlūk; Umayyad; Byzantine. Pottery pail 33 was read: Ayyūbid/Mamlūk; Umayyad.

all the fragmented material, particularly in those cases where fully articulated skeletons were found. All of the fragments seemed to be evidence of disturbance which took place, perhaps at the time of forming the cists. The fragments would be secondary burials, therefore, while the articulated remains would be primary.

Strata III and IV were also represented at the east end of the probe, east of Wall 3. Beneath a layer of topsoil (Locus 2, averaging 0.07 m. in depth) was a layer of fine grayish soil, Locus 6, which sealed against the east face of Wall 3. It averaged 0.07 m. in depth and contained an abundance of tesserae. Of 32 sherds recovered from this soil layer, two were Ayyūbid/Mamlūk, the rest being Umayyad and Byzantine.

Strata V-VI: Umayyad/'Abbāsīd (A.D. 661-969)

Immediately below the lowest of the three layers of burials a complex of three walls was unearthed. Wall 29 survived two courses high, constructed of some well-cut stone and some roughly hewn stone. Its orientation was generally east-west, extending westward out of the north balk. It was exposed to a length of 1.80 m. The height of the two surviving courses was 0.65-0.70 m. Wall 28 survived as a north-south of well-cut stone, two courses high wall. It ran perpendicular to Wall 29 and met it with a butted joint at the west balk in the northwest corner of the Square. Its exposed length was 3.65 m. and the height of the two courses was 0.70 m. The third wall, Locus 30, comprised three large stones lying in a north-south direction, running parallel with wall 28, 1.00 m. east of it and perpendicular to Wall 29, meeting it with another butted joint. It appeared that these three large stones had been reused here, having once been part of some other structure.

The plan of these walls suggested that this was a domestic complex⁶ and that it made use of the apse wall, Locus 4, at the northeast corner. In other words, Wall 4 would have served as the east, south-east wall; Wall 29 would have been the north wall; and Wall 28 would have been the west wall of the house. Wall 30 would have divided it into a two-room complex. This simple plan is still seen today in both the winter houses and summer tents of many of the residents of the village of Ḥesbān.

The only floor or surface associated with this complex was the cobble underlayer and plaster base for the mosaic floor of the Byzan-

⁶ See Fig. 19.

tine church which lay immediately beneath the complex. In fact, both Walls 28 and 29 were set directly on that mosaic floor.

The soil layer which filled the western room, Locus 39, showed clear Umayyad dominance, although several 'Abbāsīd sherds were mixed in also.⁷ A soil layer immediately above 39 (Locus 26), also sealed over Wall 30 and yielded predominantly Umayyad pottery, although some sherds were read "‘Abbāsīd/Umayyad dominant." Coin 2877, dated Early Umayyad, was found in soil Layer 26.

There was correlation in the periodization of the material east of Wall 3 with that found west of Wall 4. Locus 12 was the first pure Umayyad soil layer encountered in that sector of the Square.⁸ This layer, 0.30-0.35 m. deep, sealed against the east face of Wall 3 and consisted of a powdery, gray ash with a few pockets of fine tan soil lensing in and out. This ash material was found over, around, and under a tumble of large limestone rocks, some of which appeared to have been well cut at one time. The pottery evidence unmistakably dated this ash layer to the Umayyad period. It had all the earmarks of a large destruction layer. The question was destruction of what? No clues survived.

Beneath Locus 12 a light gray, compact clayey soil, Locus 16, was found. It too sealed against the east face of Wall 3. The average depth of this soil layer was 0.05 m. Predominantly Umayyad pottery came from Locus 16, including a well-preserved zoomorphic pitcher spout. Locus 16 sealed over Locus 19, a brown, clayish layer, 0.09 m. thick.

Locus 23 was the first clear surface found in this corner of the Square. While it was badly broken in some places, it clearly sealed against the east face of Wall 3. In conjunction with this, a patch of mosaic (0.30 x 0.20 m.) protruded from the east balk. The whitish-gray surface, Locus 23, was not the usual type of underlayer for mosaic—at least of the Byzantine period. With this scant amount of evidence it was impossible to define clearly the function of the mosaic floor. It can be said that there was some type of Umayyad settlement outside Wall 3 which was apparently destroyed by fire, hence the thick ash layer of Locus 12. A fourth-century A.D. Roman coin was found in Locus 23.

The lowest of the Umayyad soil layers in this corner was Locus 25, which was composed of reddish soil with fist-sized limestone rocks. A fair amount of predominantly Late Byzantine pottery came

⁷ Approximately 10-15 sherds out of a total of 500 were 'Abbāsīd.

⁸ Because of the layout of the Square in relationship to Wall 3, this part of the Square formed a triangle, 1.45 m. east-west along the north balk by 2.50 m. north-south along the east balk by 2.90 m. along the east face of Wall 3.

from this layer, 0.06 m. deep, though a few possible Umayyad sherds were found also.

Further excavation extended from this end of the Square would perhaps give some answers concerning the functions of Surface 23 and soil Layer 12.

Stratum VIII: Byzantine (ca. A.D. 450-614)

As previously indicated, Walls 3 and 4 were visible above ground surface prior to the start of the probe, although the relationship between the two walls was not known. Wall 4, though not much of it was exposed, very clearly appeared to be an apsidal wall of a Byzantine church. Because of the Ayyūbid/Mamlūk and Umayyad/‘Abbāsīd strata that were encountered, excavation west of Wall 4 proceeded slowly, and major developments in exposing any further church architectural features were slow in coming. Six days before the end of the season, additional architectural data were uncovered which were structurally associated with Wall 4. Meanwhile, east of Wall 3 excavation was steadily progressing, thereby gradually exposing the east face of that impressive wall. Finally, on the last digging day in the field, bedrock was reached in this sector of the Square, demonstrating that Wall 3 had, in fact, been founded in bedrock. Each locus associated with the church structure is described below.

Wall 3 was a north-south wall located in the northeast corner of the Square. Exposure of a 2.70 m. long portion of its east face to bedrock revealed the fact that it survived as a five-course wall. The upper two courses were made of large stone blocks at least 2.00 m. long x 0.35 m. wide. The uppermost course was 0.60 m. high while the next course down was 0.50 m. high. The third course down was made of well-cut stone but of somewhat smaller dimensions, 0.35-0.50 m. long x 0.35 m. wide x 0.45-0.48 m. high. The fourth course down changed somewhat, in that the stones were not nearly so well-cut as those in the three courses above, and they were of much smaller size, 0.35-0.50 m. long x 0.30 m. high x ca. 0.55 m. wide. This course was about 0.20 m. wider than the surviving three above it. The founding course was of boulder-sized rocks (0.90 m. long x 0.80 m. high and smaller) chinked with baseball- to basketball-sized stones. The total exposed surviving height of Wall 3 was 2.66 m. The pottery evidence from just above bedrock showed Late Byzantine I-II dominance (ca. A.D. 614-61) with some Early Byzantine, a small amount of Late Roman, and one Iron II/Persian sherd. On the basis of excavation and projected reconstruction by the architect, it was

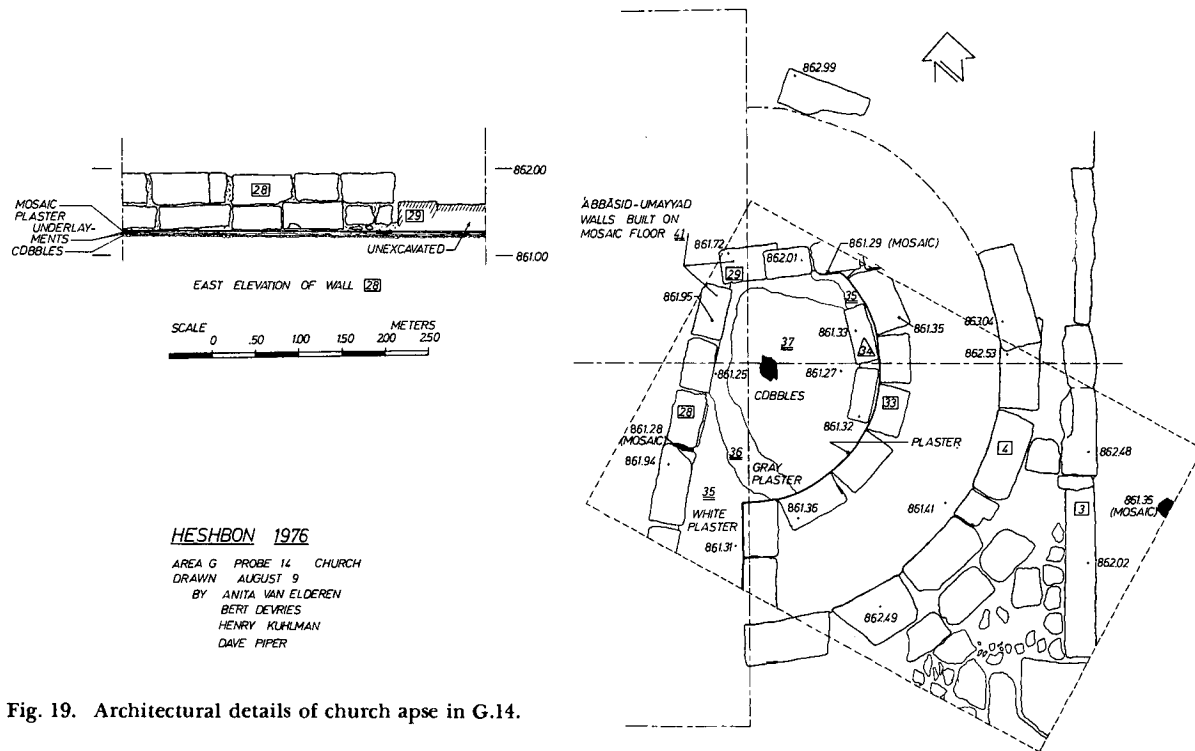

Fig. 19. Architectural details of church apse in G.14.

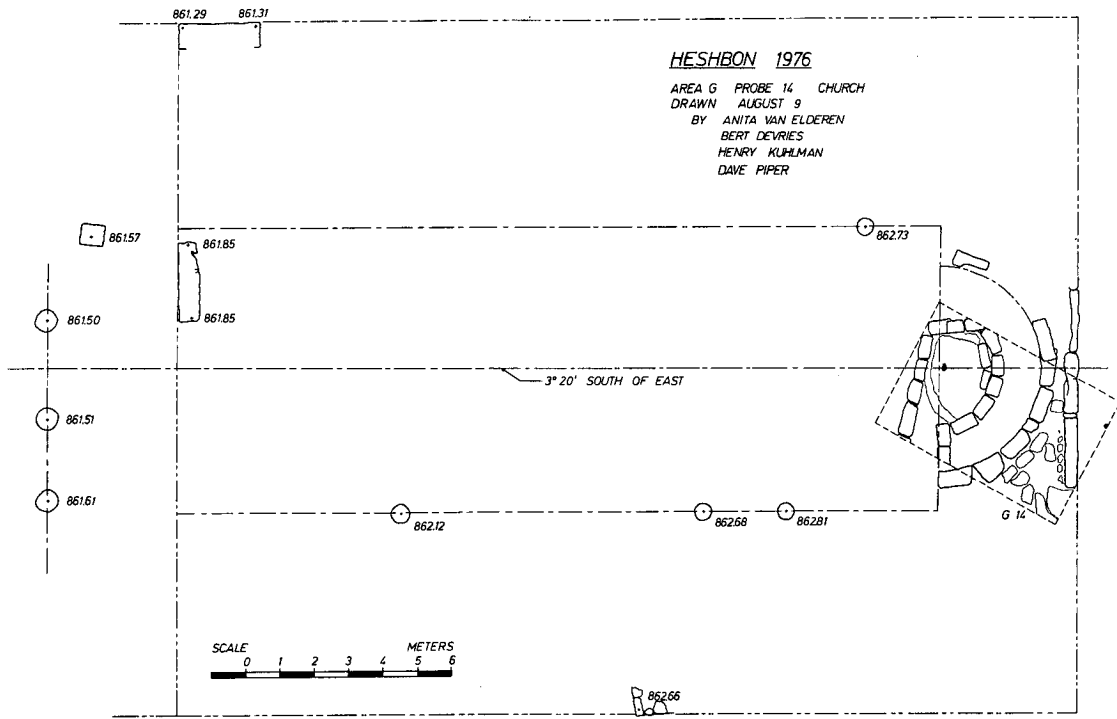

Fig. 20. Proposed outline of church plan after excavation of G.14.

quite apparent that Wall 3 was the east exterior wall of a Late Byzantine church.

Wall 4 was an apsidal wall surviving at least four courses high, each course 0.50 m. in height. Though the size of the stones varied, the average size was 0.90-1.00 m. in length x 0.45-0.50 m. in width. They were well-dressed stones on the west face; some were even slightly concave on the west face. Several observable architectural features indicated this to be the apse wall of a Byzantine church. One of our primary questions, the relationship of Walls 3 and 4, was thus answered. Wall 3 was the east exterior wall of a Byzantine church and Wall 4 was the interior apse wall. On the basis of the architect's projections it was quite clearly established that the interior diameter of the apse at the widest surviving point would have been 6.00 m. (north-south).

As excavation inside the apse continued, six associated loci were exposed: Wall 33, Locus 34, Surfaces 35, 36, 37, and Floor 41. Wall 33 was another apsidal curve 1.00 m. west of Wall 4, of smaller dimensions, and surviving to a height of 1.68 m. below the uppermost preserved course of Wall 4. The individual stones comprising Wall 33 were smaller than those in Wall 4, the average size being 0.65 m. long x 0.35 m. wide. At its west end, Wall 33 turned south, presumably joining the west end of Wall 4. Thus it was structurally associated with that wall. The two walls together gave the appearance of an apse inside an apse.⁹ The west face of Wall 33 was nicely plastered, the plaster apparently still in a good state of preservation. A plan of these walls compared with similar structures¹⁰ suggests that Wall 33 was an elders' bench in the apse of the church, and thus provided seating for the *presbyteroi* (see Pl. XV:B).

Locus 34 was directly inside (west of) Wall 33 at the head of the apse. This installation was made up of two well-dressed stones 0.62-0.65 m. in length and 0.26 m. in width. Their precise function is unknown. It has been suggested that they served as either stepping stones to the elders' bench or perhaps as a bishop's seat. Further excavation is necessary to answer this question.

Surfaces 35, 36, and 37 were associated in one sense, yet distinct in another. Surface 37 was a cobble layer which characteristically served as an underlayer for Byzantine mosaic floors. Surface 36 was a thin layer of gray plaster which leveled the top of surface 37; thus 37 was sealed under 36. Finally, 35 was a slightly deeper layer of white

⁹ See Fig. 20 for a plan of the excavated loci related to the church structure.

¹⁰ Compare the Byzantine structure at Mt. Nebo, presently under excavation and restoration by the Franciscans.

plaster, sealing over 36, which formed the cement base in which the tesserae of the mosaic floor were set.

Locus 34 was set in place after the plastering of the west face of Wall 33. Surfaces 35, 36, and 37 all sealed against the west face and the north and south ends of Locus 34, and the plaster facing of Wall 33 (to both the north and the south of 34, but not east of 34). All of this indicated that Surfaces 35, 36, and 37 and mosaic Floor 41 represent a second phase of this church and that Locus 34 probably was set on an earlier floor of the church.

Floor 41 was a mosaic floor, remnants of which were exposed and shown to be in a poor state of preservation. However, as pointed out above, the 'Abbāsid/Umayyad Walls 28 and 29 sat directly on parts of Floor 41. Thus those portions of the floor are assumed to be in a fairly good state of preservation. Those walls were left *in situ*, so the presumably better preserved portions of Floor 41 were not exposed.

The overall size of this structure, based upon evidence from the Square as well as visible architectural fragments apparently still *in situ*, has been estimated to be 15.00 m. wide x 30.00 m. long. It lay on a near perfect east-west orientation, its east end being only three degrees, twenty minutes south of east. Its founding date was probably late fifth or early sixth century A.D.

