

2012

# The Persian Period Pottery of Tall Al-'Umayri

Philip R. Drey  
*Andrews University*

Follow this and additional works at: <https://digitalcommons.andrews.edu/dissertations>

 Part of the [Art Practice Commons](#), [History Commons](#), and the [Race, Ethnicity and Post-Colonial Studies Commons](#)

---

## Recommended Citation

Drey, Philip R., "The Persian Period Pottery of Tall Al-'Umayri" (2012). *Dissertations*. 39.  
<https://digitalcommons.andrews.edu/dissertations/39>

This Dissertation is brought to you for free and open access by the Graduate Research at Digital Commons @ Andrews University. It has been accepted for inclusion in Dissertations by an authorized administrator of Digital Commons @ Andrews University. For more information, please contact [repository@andrews.edu](mailto:repository@andrews.edu).



Seek Knowledge. Affirm Faith. Change the World.

Thank you for your interest in the

**Andrews University Digital Library  
of Dissertations and Theses.**

*Please honor the copyright of this document by  
not duplicating or distributing additional copies  
in any form without the author's express written  
permission. Thanks for your cooperation.*

ABSTRACT

THE PERSIAN PERIOD POTTERY OF TALL AL-'UMAYRI

by

Philip R. Drey

Adviser: Randall W. Younker

ABSTRACT OF GRADUATE STUDENT RESEARCH

Dissertation

Andrews University

Seventh-day Adventist Theological Seminary

Title: THE PERSIAN PERIOD POTTERY OF TALL AL-‘UMAYRI

Name of researcher: Philip R. Drey

Name and degree of faculty adviser: Randall W. Younker, Ph.D.

Date completed: April 2012

Problem

In Transjordan, archaeological evidence found at well-stratified sites and dating to the Persian period (539-330 BC) has been lacking until the publication series of Tall al-‘Umayri. This dissertation determines a pottery typology of the Persian period by distinguishing between the Iron II/Persian period and the Persian period of Tall al-‘Umayri.

Method

The ceramic evidence dating to the Persian period from the site of Tall al-‘Umayri was systematically collected and organized according to the form typology set out in *Ancient Pottery of Transjordan*. The Persian pottery was then compared to Iron II/Persian pottery in order to discover differences between these two periods.

## Results

Several differences between the Iron II/Persian pottery and Persian pottery of Tall al-‘Umayri were discovered. Differences included pottery forms and characteristics appearing in the Persian period but not found in the Iron II/Persian period as well as decorative treatments.

## Conclusions

Differences between Iron II/Persian pottery and Persian pottery do exist. These differences are tangible enough to be used to separate archaeological finds and define them as belonging to the Iron II/Persian period or the Persian period.

Andrews University  
Seventh-day Adventist Theological Seminary

THE PERSIAN PERIOD POTTERY OF TALL AL-'UMAYRI

A Dissertation  
Presented in Partial Fulfillment  
of the Requirements for the Degree  
Doctor of Philosophy

by  
Philip R. Drey

April 2012

© Copyright by Philip R. Drey 2012  
All Rights Reserved

THE PERSIAN PERIOD POTTERY OF TALL AL-'UMAYRI

A dissertation  
presented in partial fulfillment  
of the requirements for the degree  
Doctor of Philosophy

by

Philip R. Drey

APPROVAL BY THE COMMITTEE:

---

Faculty Adviser,  
Randall W. Younker  
Professor of Old Testament and Biblical Archaeology

---

Director PhD: Biblical and ANE Archaeology  
Randall W. Younker

---

Paul Ray  
Adjunct Professor of Archaeology

---

Dean, SDA Theological Seminary  
Denis Fortin

---

Paul Gregor  
Professor of Old Testament and Biblical Archaeology

---

Øystein LaBianca  
Professor of Anthropology

---

Steven M. Ortiz  
Associate Professor of Archaeology and  
Biblical Backgrounds  
Southwest Baptist Theological Seminary

---

Date approved



## TABLE OF CONTENTS

LIST OF TABLES .....	v
Chapter	
1. INTRODUCTION .....	1
Problem .....	1
Purpose .....	3
Justification .....	3
Methodology .....	4
2. PROBLEMS WITH PERSIAN PERIOD POTTERY .....	6
3. PERSIAN PERIOD POTTERY TYPOLOGY OF TALL AL-'UMAYRI .....	16
Summary of Excavations of the Persian Period at Tall al-'Umayri .....	16
Pottery Typology .....	25
Bowls .....	26
Off-Set (Bi-angular, Everted) Rims .....	26
Outcurving (Everted) Rims .....	29
Straight, Vertical Simple Rims .....	32
Flattened Rims .....	36
Thickened Rims .....	39
Miscellaneous Bowl Forms .....	44
Jars .....	60
Necked Jars .....	60
Holemouth Jars .....	64
Miscellaneous Jar Forms .....	66
Jugs .....	69
Triangular, Everted (Pendant) Rims .....	70
Thickened, Crescent-shaped Rims .....	71
Vertical Necks with Simple Upright Rims .....	72
Vertical Necks with Simple, Rounded, and Everted Rims .....	73
Miscellaneous Jug Forms .....	74

4. CONCLUSIONS .....	77
Conclusions .....	77
Suggestions for Further Research .....	77
Appendices	
A. SITES AND SURVEYS.....	80
B. PARALLEL POTTERY TYPOLOGY .....	93
REFERENCE LIST .....	146

## LIST OF TABLES

1. Integrated Phases by Period and Field of the 1987 Season .....	20
2. Integrated Phases by Period and Field of the 1989 Season .....	21
3. Integrated Phases by Period and Field of the 1992 Season .....	22
4. Integrated Phases by Period and Field of the 1994 Season .....	23
5. Bowls with Off-Set Rim Profiles .....	27
6. Bowls with Outcurving Rim Profiles .....	29
7. Bowls with Simple Rim Wall Profiles .....	33
8. Bowls with Flattened Rim Profiles .....	36
9. Bowls with Thickened Rim Profiles .....	40
10. Basin Rim Profiles .....	45
11. Plates and Platters Rim Profiles .....	47
12. Holemouth Kraters with Elongated Rims .....	51
13. Holemouth Kraters with Thickened Rims .....	53
14. Types of Closed Kraters: Simple Rims .....	54
15. Types of Closed Kraters: Other Rims .....	55
16. Types of Cooking Pots .....	56
17. Types of Mortaria .....	59
18. Necked Jars .....	61
19. Holemouth Jars .....	65

20. Pithoi .....	67
21. Examples of Jugs .....	70
22. Miscellaneous Jug Forms .....	75

## CHAPTER 1

### INTRODUCTION

#### **Problem**

The rise of the Achaemenid family on the Iranian plateaus during the sixth century B.C. and, more specifically, with the fall of Babylon to Cyrus the Great in 539 B.C. marked the beginning of what has come to be known historically as the Persian period. The Persian period lasted approximately 200 years, until the arrival on the eastern Mediterranean shores in 333-32 B.C. of the Macedonian general Alexander the Great and with him the Hellenistic cultural juggernaut. Although this time span lasted for a little over two centuries, the Persian period has been called “one of the more obscure [archaeological] periods in the history of the country” (Stern 1982: vii). Although Stern was referring primarily to Israel, this description may also include Transjordan, the geographical region of this dissertation.

Three factors have contributed to this obscurity. First, besides a handful of seals and other inscriptions, the primary textual material for this period is the Bible. Biblical texts, including the Apocrypha and other Greek writings, however, relate events occurring only during the fifth century B.C. With the Persian period beginning in the mid-sixth century B.C., approximately half of the span of time is covered. This lack of primary literary sources underscores the importance of the artifactual material remains recovered by archaeological excavations and surveys.

Second, until recently, various surveys and excavations had retrieved from or attributed a very scant amount of archaeological data to the Persian period. Typically, archaeological remains dating to the Persian period have been found near the surface of tells, exposed to the natural destruction processes of erosion and decay, or have been uncovered beneath immense Hellenistic and Roman structures whose foundations damaged the architectural structures of the preceding Persian period. Based on these sparse and poorly preserved archaeological remains, pioneering explorers and travelers of the early 19<sup>th</sup> century (U. Seetzen 1806; J. Burckhardt 1812; J. Buckingham 1816; H. B. Tristram 1863-1864; C. Warren; C. R. Condor 1881) and their successors of the early 20<sup>th</sup> century (e.g., H. C. Butler 1907 and N. Glueck 1930s) concluded that during the late-sixth to late-fourth centuries B.C., the population in Transjordan must have been nonsedentary, choosing a nomadic lifestyle instead of an agrarian one.

Due to this apparent non-urban environment in Palestine during the so-called “dark age” of the sixth to fourth centuries B.C., a lacuna seemed to exist in the archaeological record during the Persian period. After all, a nonsedentary population living in tents and constantly roaming from place to place leaves hardly any evidence for the archaeologist to discover. Current archaeologists, armed with more advanced and sophisticated excavating and surveying techniques, have uncovered a significant amount of epigraphic and artifactual evidence dating to the Persian period. This evidence, for the first time, is beginning to shed considerable light upon the lifestyles of the people living during this once obscure period of history.

Third, the lack of information concerning Palestine during the Persian period may be attributed to the specialization of scholars. Earlier scholars have committed their

research interests to the more archaeological and epigraphical rich periods of the preceding Iron I-II (First Temple) period or to the following Hellenistic (Second Temple) period. Sandwiched between these two important periods, the Persian period proved uninteresting to most researchers and remained unstudied. A recent increase of interest in the Persian period, however, can be seen among (minimalist) scholars who believe the Bible was composed during this period.

### **Purpose**

The purpose of this dissertation is to establish a pottery typology of the Persian period for the site of Tall al-‘Umayri. This typology will be used to discover any ceramic changes between the Iron II/Persian period and the Persian period. The site of Tall al-‘Umayri is one of the few well-published and stratified excavations in Transjordan. The resulting pottery typology of Tall al-‘Umayri will assist archaeologists and ceramicists in dating and determining Persian period remains within the contexts of other completed or ongoing excavations.

### **Justification**

The most comprehensive survey conducted during the initial stage of archaeological exploration in Transjordan was done by Glueck in the 1930s. Based upon his findings, Glueck maintained that the three kingdoms of Transjordan (Ammon, Moab, and Edom) were destroyed during the sixth century and that this region lacked permanent occupation thereafter (Glueck 1940: 127-128). This critique of sixth-century B.C. Transjordan was held for the next 40 years, as “no evidence from excavations or the recent surveys has been uncovered so far to contradict Glueck’s conclusions” (Stern 1982: 252).

Within the last two decades, excavations and surveys in Transjordan have shown that the increase in settlements and material culture during the seventh century B.C. continued well into the next century (Barkay 1992: 357). Stern's seminal publication on the material culture of Palestine (more accurately of Israel) in the Persian period serves as an example of the progressive archaeological recognition of this time frame in Transjordan. In his introductory chapter, Stern listed only Tall as-Sa'idiyah, Tall Hisban, the tomb at Meqabelein, and the small inscription from Kerak as Transjordanian material culture dating to the Persian period. A growing catalog of sites now counts over 80 Transjordanian sites with evidence of occupation during the period under consideration. These sites include Amman, Tall Dayr-'Alla, Tall al-Mazar, Tawilan, Tall al-'Umayri, and Tall Jalul, as well as many others.

With the recent discoveries of well-preserved remains at these archaeological excavations and their subsequent publication, the Persian period in Transjordan is beginning to be represented in the archaeological record as well as in scholarly journals and reports. Thus, a study which analyzes and synthesizes these data is now necessary.

### **Methodology**

To systematically collect, examine, organize, and present the Persian period ceramic data of Tall al-'Umayri, the organization of this dissertation is topical in nature. The second chapter discusses the problems that have hindered the analysis of Persian period pottery, especially in Transjordan. The third chapter presents a pottery typology for Tall al-'Umayri. The form-based paradigm as established in *Ancient Pottery of Transjordan* (Hendrix, Drey, and Storfjell 1997) will be used to determine ceramic forms and define ceramic terms. In addition to presenting the Persian pottery, a comparison of



this pottery with Iron II/Persian pottery is included in order to offer differences between these two periods. Often, artifacts dating to the Persian period were labeled “Iron II/Persian” as archaeologists and ceramicists could not differentiate between Iron II material and Persian material. The comparison between Iron II/Persian and Persian material from Tall al-‘Umayri will assist in differentiating between these two periods. The final chapter includes concluding remarks obtained from this investigation as well as suggestions for future research. One appendix briefly sketches the historical background of Transjordan during the Persian period as well as details in a few words the past excavations and surveys conducted in this region. A second appendix offers parallel forms from other Transjordanian sites as well as non-Transjordanian sites in order to assist future research.

## CHAPTER 2

### PROBLEMS WITH PERSIAN PERIOD POTTERY

Major hurdles usually meet the initial study of ceramic evidence of any archaeological period. Lehmann (1998), in an early study of the Late Iron Age and Persian period ceramic evidence from Syria and Lebanon, listed several primary obstacles:

The excavations, the publications, and the storage of finds often lack the necessary standards. Many excavations, especially those conducted before World War II, were carried out in a way that makes it difficult to apply modern methods of analysis. Most excavations were never published in final form, and the finds that were selected for publication comprised mostly special finds or pottery of high quality. A large part of the undecorated pottery was discarded and never published. Pottery that was published has often been presented without an exact stratigraphic context. As a result, many sites lack a stratified ceramic sequence. In addition, the pottery was often stored in a way that renders it inaccessible for restudy today. Any analysis of pottery has to rely on a very limited repertoire of published finds. Finally, the clay composition of the pottery has usually been neither studied nor published. (Lehman 1998: 8)

Similar problems from the study of Syrian and Lebanese Persian period pottery were met during the study of Transjordanian Persian period pottery. In fact, the problems were intensified.

First, the number of excavations with final published field reports is surprisingly small. This number of field reports is drastically reduced when one looks for published ceramic illustrations and drawings. Of the Persian period sites in Transjordan listed in Appendix A, only 17 have illustrations of pottery, and even fewer have cross-sections. Of the 17 sites, only 11 are tells with published pottery drawings, while the other six are

cemeteries (Tall as-Sa'idiyah and Tall al-Mazar) or isolated tombs (Adoni Nur, Sahab, Amman tombs, and Meqabelein). In addition, use period of the isolated tombs is not clearly known or difficult to ascertain.

Second, sites with published Persian period pottery are not equally distributed throughout Transjordan. In the northern region of Amman, four sites and several tombs have published pottery. The central region of Moab is virtually unpublished except for two sites and a few shards found during the Kerak Survey. The southern region of Edom offers an additional five sites. This lacuna is also exhibited in surveys yielding virtually no Persian period pottery: the north Jordan survey (Mittman 1970), the *limes Arabicus* survey (Parker 1976, 1986; see also V. A. Clark 1987), the Wadi 'Isal survey (Jacobs 1983), and the Wadi el-Hesa survey (MacDonald 1982; MacDonald et al. 1988). Other surveys have reported few Persian shards: the Hisban survey found one site (Ibach 1987), the east Jordan Valley survey had 16 of 224 sites (Ibrahim, Sauer, and Yassine 1976; Yassine, Ibrahim, and Sauer 1988: 175-177, 198-199), and the Kerak Plateau survey had 20 of 443 sites with Iron IIC/Persian period and/or Persian period ceramics. This makes regional differences and similarities almost impossible to currently discern.

Third, except for the ceramic corpus primarily from Tall al-'Umayri (Herr 1995), but also from Tall al-Mazar (Yassine 1984) and more recently from Tall Dayr-'Alla (van der Kooij 1987b; van der Kooij and Ibrahim 1989: 89-90; Groot 2007; Groot and Dik 2006; 2008), Persian period pottery is not well attested in stratified contexts. Similar pottery has been found at a few other sites but most of these excavations are limited or are one-period deposits (Herr 1997: 244). Due to the lack of well-stratified sites, local pottery has been dated to the Iron II/Persian or Persian period either by association with

imported Greek pottery from the fifth and fourth centuries B.C. or based on comparison with Iron II/Persian and Persian period pottery from Palestine (primarily the sites of Tell Gezer and Tell el-Hesi, as well as the work by Stern) or other Transjordanian sites. This association has been documented at Tall Hisban, Tall al-‘Umayri, Tall Jalul, Umm Udhaina, Khilda, and Tall Dayr-‘Alla (Homès-Fredericq 1996: 74; for Greek ceramic imports into Palestine, see Stern 1982: 136-141).

Four, problems are inherent with each of the Transjordanian excavations that have published pottery illustrations. Each of the excavations from the Ammonite region has problems. Tall al-‘Umayri is an ongoing excavation with each field season producing additional pottery from the Iron Age and the Persian period, causing continuous interpretation, re-evaluation, and redating of stratigraphy. The pottery from Tall Hisban came from a Hellenistic fill with no subphasing, had been initially dated to the seventh and sixth centuries B.C., and is now currently being restudied for final publication (for example, Herr 1995; Ray 2001 and 2006; Sauer 1994: 246-248). Rujm al-Hanu published numerous shards but utilized the dating of the Hisban pottery by Lugenbeal and Sauer (1972) that has subsequently been changed.

The Amman Citadel produced much pottery and is very well published. Dornemann (1983), however, divided the pottery into two sequences, with Sequence I dating to the Iron I period and Sequence II dating primarily to the Iron II period with some pottery from the Iron III period. Dornemann used Albright’s dating system (1960: 112) which lists years for the Iron II period as 900-600 B.C. and for the Iron III period as 600-350 B.C. The Iron III period falls within the years for the Persian period, but Dornemann failed to distinguish which pottery came from the Iron III period. Each of the

isolated tombs from this region (Adoni Nur, Sahab, Amman, and Meqabelein) has unsure dating. The cemeteries from the sites of Tall as-Sa‘idiyah and Tall al-Mazar have produced some significant Persian period forms, but one must be cautious in using forms from tombs to date stratigraphic remains.

The Moabite region is very poorly published. The three excavations of Moabite finds include Aroer, Dhiban, and Tall Dayr-‘Alla. The Kerak survey yielded several Persian shards as well as Iron II shards. However, Brown published the ceramic remains using the Hisban corpus by Lugenbeal and Sauer (1972) to date much of the Iron II forms. With the revised dating of the Hisban corpus, more Kerak shards dating to the Iron II period may now be dated down into the Persian period. Excavations at Tall Dayr-‘Alla during the 1980s revealed four possible phases of Persian period occupation, but these findings have only recently been published (van der Kooij 1987; Groot 2007; Groot and Dik 2006, 2008).

The Edomite region has five sites, most of which have been fairly well published (most recently, Tawilan). The dating of these sites was originally only to the Iron II period (seventh and sixth centuries B.C.) but has now been pushed down into the Persian period (fifth century B.C.) as well. However, the ceramic sequencing of the Edomite pottery (especially from Tawilan) is based on assumptions (Bienkowski 1995: 102) and not on ceramic evidence as no typical Persian period forms have been found. In addition, most of the Edomite sites are one-period sites so there is no stratigraphic sequencing.

Five, the assumption that an occupational gap existed from the end of the Iron II period to the Hellenistic period has greatly reduced the number of pottery shards (and therefore sites) assigned to the Persian period. In Transjordan, the approximate two

centuries between the fall of Babylon to Cyrus of Persia in 539 B.C. and the arrival of Alexander the Great on the shores of the eastern Mediterranean Sea in 332 B.C. are commonly known as the Persian period (for other dates and names of this time span, see: Ottosson 1993: 100; Strange 1997; McGovern 1989: 40-42; Miller 1991; Greene and ‘Amr 1992: 126; Younker, Geraty, Herr, and LaBianca 1990: 13; Ibach 1987: 158-168). Thus, this period is framed by two well-known periods, the preceding Iron Age and the following Hellenistic period. Both the Iron Age and the Hellenistic period are rich with artifacts. The Persian period, especially in the region of Transjordan, has not been as artifactually fortunate as these other two periods.

Due to the scarcity of archaeological remains in Transjordan, the Persian period had been thought of being composed of a nonsedentary population. Glueck’s surveys of the 1930s and his conclusions provided fuel for this reasoning and gave it false assurance. Glueck “had conducted the first exhaustive survey of Transjordan. He postulated a thriving Edomite kingdom from the thirteenth century B.C. on, and an occupational gap from the end of Iron II to the Hellenistic and Nabataean periods (i.e. *c.* sixth-fourth centuries B.C.)” (Bienkowski 1990b: 103).

To this idea, which was conveniently accepted by some scholars, was later added the opinion that Edom and Moab were both raided by nomadic Arab tribes (Ezek 25:4; see Eph’al 1988: 163; Lemaire 1994b: 51; Sapin 1996). These tribes were identified with the Qedarite Arabs who had control over “the sparsely populated areas that were not occupied by a settled people” (Stern 1990: 223). Due to this and to the resulting low level of archaeological interest, the Persian period was often considered together with Babylonian or Hellenistic periods. As Hadidi lamented, “Little is known of Jordan’s

history during the Persian domination (c. 539-332 B.C.). According to Herodotus, Darius I (522-485 B.C.) reorganized the administration of the Persian Empire into twenty *satrapies* or provinces. Jordan was placed under the fifth *satrapy* of Palestine. As more sites are excavated, surely more evidence of this virtually unknown period of Jordanian history will be available” (Hadidi 1982: 18).

Beginning in the 1950s and continuing to the present, more sites and excavations of this virtually unknown period were investigated, utilizing new techniques, more precise digging methods, and comparative studies. Spotty archaeological evidence from the sixth and fourth centuries B.C. started to trickle in from a few isolated tomb deposits at Meqabelein, Umm Udhaina, and Khilda as well as from cemeteries from Tall al-Mazar and Tall as-Sa‘idiyah. Other initial finds mostly included foreign imports of Attic pottery from Greece and a very few contemporary inscriptions. The findings from these excavations are beginning to change conclusions about the Persian period (van der Kooij 1987: 97).

Prior to the 1970s, most archaeologists ended the occupation dates of their site with the campaign of Nebuchadnezzar in 586 B.C. based on the reasoning that this campaign resulted in the abandonment of Judea and, therefore, also of Transjordan (Josephus 10.9.7). Because of this assumption of an Exilic abandonment, archaeologists provided their sites with an agreeable occupational gap between the Iron II period and the Hellenistic period. In addition, as will be illustrated below, complicating factors contributing to this problem are the lack of destruction layers at the Transjordanian sites between the Iron II and Persian periods and that much of the Iron II corpus continued

relatively unchanged into the Persian period, making a distinction between Iron II and Persian period pottery virtually impossible.

This problem further complicates the study of the Persian period because of the use of parallel forms to date pottery. This difficulty is best seen in the use of the Tall Hisban corpus published by Lugenbeal and Sauer (1972). In their initial dating, Lugenbeal and Sauer assigned a seventh- and sixth-century B.C. date to the corpus. In order to date many subsequent Transjordanian (and Cisjordanian) excavations, archaeologists have utilized the Hisban corpus and its initial dating. However, Sauer (1986, 1994) has recently re-dated the Hisban corpus, pushing its date down to include the fifth and fourth centuries B.C. The dilemma remains as to how this re-dating of the Hisban corpus effects the dating of the excavations that had utilized the Hisban corpus as its dating standard.

A final problem complicating this study of Persian period pottery is dating terminology employed by published works. Authors of excavation reports have chosen various terms (historical, ethnic, political, or cultural) to describe the dating of Persian period findings:

The periodization system, even of the archaeological record, reflects historical events rather than internal developments of the material record itself. Often, ethnic or political terms like 'Neo-Assyrian,' 'Neo-Babylonian,' 'Persian,' or 'Achaemenid' are used to date the changes and developments of archaeological finds. Too often the material record is related in a somewhat naive way to known historical events. On the contrary, one should expect to study the archaeological record independent of the historical record before connecting them, to find an absolute date for archaeological finds. All too often it is assumed that a historical change led to an immediate change in the material culture. However, an archaeological periodization system should be based only on an analysis of the material record. Furthermore, it should be related to the historical record only after it appears completely consistent internally. (Lehmann 1998: 7)



An understanding of this dating complication can be attained by briefly looking at several chronological frameworks for the Iron Age. The first framework from Loud and Shipton (Loud 1948: 5; Shipton 1973: 4) uses metallurgical terms such as “Early Iron I,” “Early Iron II,” “Middle Iron,” and “Late Iron” to describe the periods. The dating for each period follows: Early Iron I (1200-1150 B.C.), Early Iron II (1150-1000 B.C.), Middle Iron (1000-600 B.C.), and Late Iron (600-350 B.C.). The second framework is from Aharoni and Amiran (1958: 172). These scholars used the ethnic term “Israelite,” “Neo-Babylonian,” and “Persian” to title the periods (dates included): Israelite I (1200-1000 B.C.), Israelite II (1000-840 B.C.), Israelite III (840-600 B.C.), Neo-Babylonian (600-500 B.C.), and Persian (500-300 B.C.). Another chronological framework comes from Albright (1960/9: 112) in which he used metallurgical names similar to Loud and Shipton but with drastically different dates: Iron I (1200-900 B.C.), Iron II (900-600 B.C.), and Iron III (600-350 B.C.).

As can readily be seen, all frameworks possess a dating break at 600 B.C. Loud and Shipton and Albright all agree that the break at 600 B.C. ends at 350 B.C. but Aharoni and Amiran end the break at 500 B.C., using a subsequent period (Persian). In addition to this, one can see that the use of period titles and period dates varies quite a bit between the frameworks. This variation leads to much confusion when attempting to reconcile data from various published reports when the authors use different terms and dates. For example, specific to Transjordan, Dornemann used Albright and his dating since most Palestinian parallels he used were dated using his scheme, and most subsequent stratigraphy of Transjordan has been arranged by it.

Excavation reports of Persian period finds in Transjordan present an added difficulty to the discussion of chronological frameworks. Often, the Persian period is not viewed as a separate period but an “add-on” to the preceding Iron Age. According to Akkadica Archaeology of Jordan (10), the Persian period is termed “Iron Age III,” with a date of 539-332 B.C. and with the Iron Age IIc dating from 800-539 B.C. Brown (1991: 27) does use the title “Iron Age IIc” but combines it with “Persian” to form an “Iron IIC/Persian” period, abbreviating it as “Pers.” Also, the date limits of Brown’s Iron IIC/Persian period are 540-332 B.C. Finally, Vilders (1995: 597) lumps all time from the Late Bronze Age II to Iron Age III (c. 1250-600 B.C.) based on cooking pots from Tall as-Sa‘idiyah.

A final chronological framework comes from the Madaba Plains Project series and is utilized at Tall al-‘Umayri, the type site of this dissertation (Herr 2002b: xii). Period terms are similar to those of Albright but with different dates: Iron I (ca. 1200-1000 B.C.), Iron II (ca. 1000-539 B.C.), and Iron II/Persian (Iron III) (539-332 B.C.). This framework combines the Persian period with the latter part of the Iron II period, thereby not distinguishing a separation between the Iron II and Persian periods. It should be noted, though, that the term “Persian” period is often used throughout the series. For dating purposes here, the chronological framework of Tall al-‘Umayri is used.

Given all these impediments, it may seem premature to provide any discussion of pottery during the Persian period. Excavations at new or already-excavated sites are continuing each field season, and any new find from published field reports would greatly add to and/or alter a ceramic typology. To bring together available data (no matter its shortcomings) at this time and to provide a framework of available pottery evidence (no

matter how preliminary), however, is important to the study of the Persian period and to future excavations of Persian period sites. A broad framework must be commenced now in order for it to be filled in, supplemented, and redacted with more secure data later.

## CHAPTER 3

### PERSIAN PERIOD POTTERY TYPOLOGY OF TALL AL-‘UMAYRI

#### **Summary of Excavations of the Persian Period at Tall al-‘Umayri**

From the results of the initial archaeological survey and excavation in 1984, the site of Tall al-‘Umayri suggested its importance as an Iron II/Persian period and Persian period site. Previous to these excavations and prior to those at Tall Hisban,

the pottery from the late Iron II and Persian periods in central Transjordan was known only from a few isolated tomb deposits. Dates were given to these assemblages in the Iron II period based on rather weak parallels from western Palestine and on one or two inscribed seals. (Herr 1997c: 244)

In the early 1970s, the publication of findings from the Tall Hisban excavations brought the first true stratigraphic pottery sequencing to these periods. In the 1972 study by James Sauer and Edward Lugenbeal, the Tall Hisban pottery assemblage was dated to the seventh and sixth centuries B.C. based on comparison to Palestinian pottery during the late Iron II period. In addition, Sauer pointed out forms unique to Transjordan which made up the majority of the ceramic corpus. As Herr indicated, Sauer’s “dating has been followed by most researchers since” (Herr 1997c: 244).

As Sauer continued work on the Hisban pottery, his dating of the corpus changed. Sauer subsequently concluded that the basic forms of the Tall Hisban pottery were not restricted to the late Iron II period. These forms continued later than the sixth century, possibly even into the fourth century. Unfortunately, this discovery was never published,

only being made through oral lectures and personal communications, and so scholars working in Transjordan never seriously implemented them (Herr 1997c: 244).

In addition to Sauer's suspicions of a temporal extension of the ceramic material, the Tall Hisban corpus itself was problematic. Most of the ceramic corpus was excavated from an immense Hellenistic fill in a reservoir dating to the Iron II period. Subphasing in this fill could not be determined. Similar pottery to that of Tall Hisban, however, was beginning to appear in large amounts at other nearby sites in the Ammonite region. This newly discovered pottery, unfortunately, came either from limited excavations (such as from the citadel at Amman), from deposits of a single period, or from tombs whose length of usage could not be clearly determined. Thus, these pottery assemblages were of little assistance to understanding the ceramic sequencing at Tall Hisban (Herr 1997c: 244).

Although pottery from other Ammonite sites was unable to substantiate Sauer's suspicions of extending the Tall Hisban corpus past the sixth century, assistance did come from inscriptions. Aramaic ostraca from Tall Hisban dated on paleographic evidence to the late sixth century (Cross 1969a; 1973a). This new evidence allowed the Tall Hisban pottery assemblage to be dated to almost the end of the sixth century, but not thereafter.

In the 1980s, the supporting evidence Sauer had been seeking began to emerge with the excavations at Tall al-'Umayri. The 1984 surface survey and excavations uncovered two cylinder seals dating between the sixth to fifth centuries B.C. (Porada 1989: 381-384). In addition, a closed lamp suggesting a Persian period date was found. This lamp, however, was highly burnished, a feature common to the Iron II period (Herr 1989: fig. 19.17:14; 1997b: 244). Other excavated open lamps were shallow and more

typical of the Persian period (Herr 1989: fig. 19.17:15-16). These artifacts dated to the late sixth century B.C. based on a comparison of the Tall al-‘Umayri pottery to the Tall Hisban pottery and its dating to the late sixth century B.C. (prior to the revision by Sauer). This dating was then substantiated because “typical Persian forms from western Palestine were missing, such as *mortaria*, necked cooking pots, and sausage jars” (Herr 1997c: 244).

Except for the cylinder seals and lamps, very little reference was made in the publication about the Persian period. Excavated pottery was compared to Sauer’s published Tall Hisban corpus as “other assemblages (were) either only partially published, or not published at all” (Herr 1989: 299). The pottery was combined into Integrated Phases, with Integrated Phase 3 roughly being dated to the Iron II/Persian period and Integrated Phase 2 possibly dating to the Persian period. No Field Phases were attributed to the Integrated Phases.

The results of the 1987 season were published in 1991 as the second volume of the *Madaba Plains Project*. In this volume, the Persian period was described as an “abatement” of the intensification during the preceding Iron Age (Herr 1991a: 13). During this period, an Ammonite Citadel in Field A was understood to have been rebuilt on a much smaller scale, both in size and in quality of construction. An Attic kylix shard found beneath the floor of the citadel indicated a construction date in the late sixth or early fifth centuries B.C. The presence of the Attic shard at Tall al-‘Umayri, as well as other sites including Tall Jalul, “supports Stern’s idea that there were several ports along the Mediterranean coast through which these Attic-ware vessels reached the interior of Palestine, including Transjordan” (Younker 2009: 264).

In addition, a lack of well-defined surfaces hinted at a short use of the building in Field A. After the destruction of the citadel and a four-pillared house, a small plastered pool was constructed. The pool, still with steps leading to its floor, was built in the space of the house ruins. Pottery from the pool was dated to the Early Persian period, although the pool has since been interpreted to be an Early Roman bath, or miqveh.

In Field F, the gate fortification was believed to have been no longer used during the Persian period. In its place was found a series of pits and short-lived terrace walls. The pits and terrace walls suggested that the acropolis was now used only for small domestic functions and not for governmental administration. Similar to pottery from the pool, the pottery from the terrace wall excavations dated to the Early Persian period.

The archaeological data of the 1987 season were collected and organized. The stratigraphy of each field was broken into Field Phases (FP), “a coherent Field-wide stratigraphic unit reflecting phase of architectural and activity patterns” (Herr 1991a: 13). Combining all of the Field Phases resulted in 23 Integrated Phases (IP). The published dating of the Integrated Phases pertaining to the Persian period can be found in Table 1 (Herr 1991a: 12).

The results of the 1989 season were published in 1997 as the third volume of the *Madaba Plains Project* (Herr 1997b: 7-20). Of most significance, two ‘mn (‘Ammon) stamped jar impressions were uncovered in a building of Field A. The Aramaic script of the seal impressions suggested a date after the mid-sixth century B.C. (Herr 1997a: 325-327). A third seal impression on a jar rim was found in the topsoil. The script of the three Aramaic letters (*bʿl*) of the impression suggested a late sixth- to early fifth-century B.C. date. The jar handle itself corroborated this dating as the handle is not a typical late Iron

II form but is more similar to Persian period forms at Tell el-Hesi and Tell Gezer (Herr 1997a: 328). These three seal impressions, combined with the 1984 discovery of a *b'lyš'* (Ba'alyasha') seal impression in the topsoil of what would become Field H, led to the understanding that the buildings functioned as a royal Ammonite government building, from the late Iron II period to the Persian period under the Persian province of 'Ammon.

TABLE 1

INTEGRATED PHASES BY PERIOD AND FIELD OF THE 1987 SEASON

IP#	Period	Field A	Field B	Field C	Field E	Field F
17	LIron II/ EPersian	FP3B	FP4	FP2	FP4	FP4
18	LIron II/ EPersian	FP3A	FP3			
19	EPersian	FP2	FP2			FP3

*Source:* From L. G. Herr, *Madaba Plains Project 2: The 1987 Season at Tell el-'Umeiri and Vicinity and Subsequent Studies* (Berrien Springs, MI: Andrews University Press in cooperation with the Institute of Archaeology, 1991), figure 2.4. Reprinted with permission.

The decline of population, as postulated in the second volume of the *Madaba Plains Project*, was further substantiated during the 1989 field season. The discovery in Field A of structures with small rooms located east of the citadel further supported its apparent loss of government function. Domestic buildings found in Field B were structurally changed. And the terrace walls in Field F were located outside of a shrinking settlement, further confirming the apparent abatement. The settlement itself stopped functioning during the later fifth or fourth centuries B.C.



Based on the archaeological evidence collected in 1989, the dating of the Integrated Phases was modified. The revised dating of the Integrated Phases pertaining to the Persian period can be found in Table 2 (Herr 1997b: 11).

The results of the 1992 season at Tall al-‘Umayri were published in 2000 as the fourth volume of the *Madaba Plains Project* (Herr 2000a: 7-20). Archaeological artifacts uncovered in 1992 further supported the findings of the previous three field seasons. Slight alterations, including the change of the size of the rooms or adding a doorway, to rooms of the domestic structures in Fields A, B, and F were found. The frail fortifications constructed in the late Iron II/Persian period showed evidence of continued use, as did a plastered channel which brought water to the northeast side of the tell.

TABLE 2  
INTEGRATED PHASES BY PERIOD AND FIELD OF THE 1989 SEASON

IP#	Period	Field A	Field B	Field C	Field E	Field F
8	LIron II/ EPersian	FP5	FP6		FP4	FP5
7	EPersian	FP4	FP5?	FP2?	FP4	FP4?
6	EPersian	FP3	FP4		FP4	FP3

*Source:* From L. G. Herr, *Madaba Plains Project 3: The 1989 Season at Tell el-‘Umeiri and Vicinity and Subsequent Studies* (Berrien Springs, MI: Andrews University Press in cooperation with the Institute of Archaeology, 1991), figure 2.8. Reprinted with permission.

Archaeological evidence still supported the understanding that the Ammonite administrative buildings were no longer used, as detailed in the previous volumes. With the dominance of the Persian Empire, local administrative structures were of no

importance. Trade with Egypt was possibly indicated by the uncovering of an Egyptian faience amulet (sometimes called a *Pataikos* figurine) in Field F (Herr 2000a: 17; Dabrowski 2000: 215-220). The cessation of occupation during the late fifth or fourth centuries B.C. continued to be accepted.

Based on the archaeological evidence collected in 1992, the dating of the Integrated Phases was revised. The adjusted dating of the Integrated Phases pertaining to the Persian period can be found in Table 3 (Herr 2000a: 11). Note the change in Field Phase (FP) numbers and the further separation of the Persian period into three Integrated Phases.

TABLE 3  
INTEGRATED PHASES BY PERIOD AND FIELD OF THE 1992 SEASON

IP#	Period	Field A	Field B	Field C	Field E	Field F
8	LIron II/ Persian	FP6	FP7	FP3?	FP5	FP5?
7	Persian	FP5	FP6	FP2?	FP4	FP4?
6	Persian	FP4	FP5	FP2?	FP4	FP3?
5	Persian	FP3	FP4	FP2?	FP4	FP3?

*Source:* From L. G. Herr, *Madaba Plains Project - 'Umayri 4: The 1992 Season at Tall al-'Umayri and Subsequent Studies* (Berrien Springs, MI: Andrews University Press in cooperation with the Institute of Archaeology, 1991), figure 2.3. Reprinted with permission.

The results of the 1994 excavation season were published in 2002 as the fifth volume of the *Madaba Plains Project* (Herr 2002a: 8-22). Work continued in Field A with the deepening of three squares in the northern part of the field. In one of these squares, a pottery cache of 18 stackable ceramic vessels was uncovered. These vessels

were typical of Ammonite forms. South of Field A, a new field (H) was opened in which a small room dating to the late Iron II or early Persian periods was uncovered (Herr 2002a: 11-12). Archaeological artifacts collected during this field season further supported the understanding of population abatement during the Persian period.

Based on the archaeological evidence collected in 1994, the dating of the Integrated Phases was again revised. The amended dating of the Integrated Phases pertaining to the Persian period can be found in Table 4 (Herr 2002a: 13). Note the number changes in terms of the Field Phases when compared to Table 3 and the addition of Field H. The “N” under Field A represents the squares deepened in 1994.

TABLE 4  
INTEGRATED PHASES BY PERIOD AND FIELD OF THE 1994 SEASON

IP#	Period	Field A	Field B	Field C	Field E	Field F	Field H
8	LIron II/ Persian	FP7, 5N		FP3?	FP5	FP6	FP5?
7	Persian	FP6, 4N	FP6	FP2?	FP4	FP5	FP4?
6	Persian	FP5, 3N	FP5	FP2?	FP4	FP4	FP3?
5	Persian	FP4	FP4	FP2?	FP4	FP3	FP3?

*Source:* From L. G. Herr, *Madaba Plains Project - ‘Umayri 5: The 1994 Season at Tall al-‘Umayri and Subsequent Studies* (Berrien Springs, MI: Andrews University Press in cooperation with the Institute of Archaeology, 1991), figure 2.3. Reprinted with permission.

Through his detailed analysis of the Tall al-‘Umayri pottery, Herr has placed the beginning date of the Iron IIC/Persian period ceramic assemblage in the seventh century B.C. (Herr 1995: 618). This date was based on a parallel to a typical black-burnished Ammonite bowl (in ware and form) found at Tell Batash (Kelm and Mazar 1985: 110,

no. 4). An identical rim on the black-burnished bowl was found at Tall al-‘Umayri in 1984 (Herr 1989: fig. 19.9:25; Herr 2006).

The ending date for the ‘Umayri ceramic assemblage is a bit more difficult to place (Herr 1995: 618-619). Several forms from the assemblage appeared to have Persian period parallels based on Sterns’s analysis of Persian period pottery from Palestine (1982) and the discoveries from Tell el-Hesi (Bennett and Blakely 1989) and Tell Gezer (Gitin 1990). According to Herr, these Persian period parallels include: triangular jar and jug rims on an assortment of forms (Herr 1989: fig. 19.5:9-17, 22-24; Lawlor 1997: fig. 3.16:5, 7, 9, 11-13); a triangular jug rim reminiscent of an early Hellenistic form (Herr 1989: fig. 19.6:19); a necked krater similar to Persian period forms (Herr 1989: fig. 19.7:11); several bowl forms appearing more Persian than Iron II (Lawlor 1991: figs. 3.14: 22-27; 3.25:24-25), including those with flaring, everted rims (Lawlor 1997: fig. 3.17:6-9) or deep hemispherical forms, possibly with a groove on the exterior surface below the rim (Lawlor 1991: fig. 3.14: 22-27; 1997: fig. 3.17:18); possible Persian period necked cooking pots (Lawlor 1997: fig. 3.18:1-2); chevron decoration (Lawlor 1997: fig. 3.22:12); and shallow (Lawlor 1997: fig. 3.18:4-6) or closed lamps (Lawlor 1997: fig. 3.23:3). In addition to these forms, the Iron II period characteristic of wheel burnishing appears to continue “virtually unchanged through most of the Persian period” (Herr 1995: 619). However, completely lacking from the Tall al-‘Umayri corpus are typical Persian period forms like sausage jars, high-necked cooking pots, and amphoras as well as mortoria and shallow rounded bowls which are present but rare (Herr 1995: 619). The missing “typical” Persian period forms were attributed to “regional differences between the assemblages in western and eastern Palestine” (Herr 1997c: 245).

## Pottery Typology

The typological study of the Persian period pottery and its comparison to the Iron II/Persian period pottery will essentially be descriptive according to the broad ceramic form categories of bowls, jars, and jugs. Whenever possible, ceramic forms and terms as defined in the book *Ancient Pottery of Transjordan* (Hendrix, Drey, and Storfjell 1997) will be employed. Each of the form categories is further divided according to pottery types found within that category. The bowl form category includes basins, cooking pots, and kraters as well as plates, platters, cups, and mugs. The jar form category includes holemouth jars, necked jars, pithoi, and amphorae and amphoriskoi. The jug form category includes jugs and juglets, with the specialized forms of alabastrons, bottles, decanters, and flasks. Since very few whole forms have been found at Tall al-‘Umayri, each of these sub-categories will be divided according to variations of rim profiles or other diagnostic characteristics. Through this typological analysis, form variations and development will be discerned in order to better clarify Persian period pottery as well as to distinguish it from the preceding Iron II/Persian period.

When discussing pottery forms from Tall al-‘Umayri, only the second, third, fourth, and fifth volumes of the *Madaba Plains Project* series are used. As it does not include enough detail to make sound stratigraphic conclusions and divided stratigraphy only by integrated phases and not field phases (as in the following four volumes), the first volume is used only for parallels, if applicable and needed.

## Bowls

### **Off-Set (Bi-angular, Everted) Rims**

The off-set (bi-angular, everted) rim is the most common type of rim profile of any form category at Tall al-‘Umayri. Its most basic characteristic is the small “inset” at the inflection point where the rim joins the body. This noticeable inset distinguishes the off-set rim profile from the outcurving rim profile, which is discussed below.

According to stratigraphic evidence of these rims, off-set rims date from the Early or Late Iron II period through the Persian period (see Low 1991: figs. 8.8:3-7; 8.12:5; 8.15:7-21; 1997: fig. 7.15:20-24 for Late Iron II parallels). The rim changed very little through these periods, and distinguishing differences between the rims are difficult to find. Several possible differences between the Iron II/Persian period examples and the Persian period examples (Herr 1989: 308) include more rounded angles (Lawlor 1997: fig. 3.16:11; 2000: fig. 3.29:22; see also Herr 1989: fig. 19.14:10, 14) and a lower outer groove on the rim of the Persian period examples, which may be below the inner step (Herr 1989: fig. 19.14:10-14). This lower outer groove does not seem prevalent in the Persian period. One other possible difference between the Late Iron II examples and the Iron II/Persian period and Persian period examples is the lack of interior incising on the Late Iron II period forms, with the incising beginning in the Iron II/Persian period (Low 1991: fig. 8.21:2) and increasing into the Persian period (Herr 1989: 19.14:9-10, 13, 15; Lawlor 1991: fig. 3.25:20). Interior incising, however, is very rarely utilized to decorate this rim type.

Rim profiles range from flat to rounded (Table 5). Flat rim profiles can be dated to the Iron II/Persian period (Lawlor 2000: fig. 3.29:17-20; Low 1997: fig. 7.15:20-24) as

well as to the Persian period (D. R. Clark 2002: figs. 4.44:8-10; 4.45:1, 3, 7-9, 12; Lawlor 1991: figs. 3.13:6, 10; 3.25:16, 18-21; 1997: figs. 3.16:4, 6-7, 9; 3.22:17; 2000: fig. 3.33:6; 2002: fig. 3.18:1; Low 1991: fig. 8.21:1-2, 4-7, 9). Rounded profiles also can be dated to the Iron II/Persian period (Lawlor 2000: fig. 3.29:21-23) and to the Persian period (D. R. Clark 2002: fig. 4.45:2, 4-6, 10-11; Lawlor 1991: figs. 3.13:9; 3.25:17; 1997: figs. 3.12:6; 3.16:3, 5, 8, 10-11, 18; Low 1991: fig. 8.21:3, 8, 10). Flat rim profiles seem to be more numerous than rounded profiles during the Iron II/Persian period but both are well represented during the Persian period.

TABLE 5  
BOWLS WITH OFF-SET RIM PROFILES

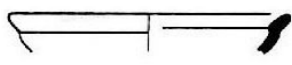
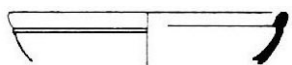
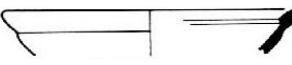
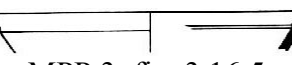
Period	Flat Profile	Rounded Profile
Iron II/Persian	 MPP 4: fig. 3.29:18	 MPP 4: fig. 3.29:22
Persian	 MPP 4: fig. 3.16:6	 MPP 3: fig. 3.16:5

*Note.* Drawing is not to scale.

The grooving on off-set rims can be significant (e.g., Low 1991: fig. 8.21:1-5) to almost non-existent (e.g., D. R. Clark 2002: fig. 4.44:10; Lawlor 1991: fig. 3.13:10; see also Herr 1989: fig. 19.14:10, 12). The rims may have exterior ridging (or a double groove) just below the outer grooving on the wall (D. R. Clark 2002: fig. 4.45:10; see also Herr 1989: fig. 19.7:21-23). The exterior ridging seems to have begun in the Later

Iron II period (Low 1991: fig. 8.15:11) and continued into the Persian period, although it is not represented on Iron II/Persian period shards.

The ware is generally thin, but several thick examples have been found (Lawlor 2000: fig. 3.29:23; see also Herr 1989: fig. 19.8:2-4). Overall, Persian period wares seem to be thinner than Iron II/Persian period wares. Exterior and interior ware colors in the Persian period include light red, light reddish brown, pink, reddish yellow, and dark gray with most core colors being gray but also light reddish brown and light gray. The Iron II/Persian period forms also had ware colors of gray (gray, very dark gray, and pinkish gray) and light brown cores. The bowls were all wheel-made.

Rims are usually set on shallow bowls. No whole forms were uncovered, but several shards hinted at a rounded to slightly carinated wall profile (e.g., Clark 2002: fig. 4.44:8-10; Lawlor 1991: fig. 3.25:21; see also Herr 1987: fig. 19.14:14). Due to the lack of whole forms, no vessels with bases were found.

Surface treatment in both periods included light to medium slips (red, light red, pinkish gray, dark gray, light gray, light reddish brown, pale brown, brown) on the interior and exterior, light to heavy wheel burnish, design burnish, and lines. Decoration included ridging on the rim, neck, and shoulder as well as burnishing (black and gray). The Iron II/Persian period forms also had slip colors of red (reddish yellow, dark red, pale red, or dusky red), gray (gray or very dark gray), and pink. Also, decoration included ridging and incising on rims and necks, tool and finger impressions on rim and necks, and gray burnishing.





## Outcurving (Everted) Rims

The second type of bowl rim profile found at Tall al-‘Umayri flares outward (an outcurving inflection). Since this outcurving rim appears very similar to the off-set rim previously discussed, these two rim profiles are oftentimes very difficult to differentiate. Not only is this profile common in the Persian and Iron II/Persian periods, it was also frequent as early as the tenth century B.C. For purposes here, rims with an outcurving inflection may be categorized with a more S-shaped profile, a doubled or pendant profile, or an everted flattened rim profile (Table 6).

Its outcurving, everted rim that flares from the sidewall of the bowl typifies the S-shaped rim profile. This rim profile is common during the Iron II/Persian period (Lawlor 2000: fig. 3.29:24-27, 32-35; Low 1997: fig. 7.16:1-5, 14) but more so during the Persian period (Berge and Willis 2002: fig. 5.13:17; D. R. Clark 2000: fig. 4.36:9-10; 2002: fig. 4.45:13, 15-19; Lawlor 1991: fig. 3.13:16; 1997: figs. 3.16:15-18; 3.17:7-8; 3.22:19, 21; 2002: fig. 3.19:12-13; Low 1991: fig. 8.21:16-21, 25).

TABLE 6

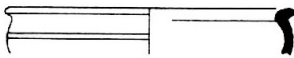
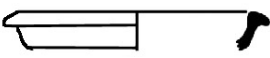
### BOWLS WITH OUTCURVING RIM PROFILES

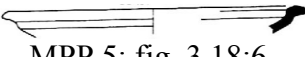
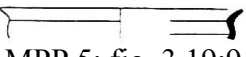
Period	S-shaped profile	Pendant Profile	Flattened Profile
Iron II/ Persian	 MPP 4: fig. 3.29:24	 MPP 3: fig. 7.16:12	 MPP 5: fig. 4.43:5
Persian	 MPP 5: fig. 3.19:12	 MPP 5: fig. 3.18:6	 MPP 5: fig. 3.19:9

*Note.* Drawing is not to scale.

Lips on S-shaped rims are usually rounded but may be also squared or flat (e.g., Lawlor 1997: figs. 3.16:18; 3.22:21; 2000: fig. 3.29:34). Some rims with rounded lips also appear very short (e.g., D. R. Clark 2002: fig. 4.25:16, 19; Lawlor 1997: fig. 3.22:19) during the Persian period but a short rim was also found on an Iron II/Persian period vessel (Lawlor 2000: fig. 3.29:35). A variant form of the squared lip possesses grooves (D. R. Clark 2000: fig. 4.36:9; Lawlor 1997: figs. 3.16:17-18; 3.22:21; see also Herr 1989: fig. 19.9:26, 29). These grooved lips seem to occur mostly during the Persian period on bowls with ungrooved walls but one Iron II/Persian period lip was found (Lawlor 1997: fig. 7.16:4) on an ungrooved bowl.

The sidewalls of S-shaped bowls appear rather globular or rounded. The walls may possess no grooving or grooving on the upper shoulder. The grooves may be single but generally are numerous. During the Persian period, the grooves are not as defined as they are in the previous Iron II/Persian period (Herr 1989: 305). Ungrooved vessels usually have rounded-to-carinated walls, while grooved vessels are deeper and rounder. One whole vessel was discovered to have a disk base (Lawlor 1997: fig. 3.17:4) but little can be said about the depth of the bowls, although the everted, flaring rim seems to appear mostly on deeper bowls.

A doubled-over (or pendant) rim that is pointing to the base of the vessel but still contains a gap between the vessel wall and the rim characterizes the pendant rim profile, the second category of rim profiles. According to Herr (1995: 618; 1997: 245), this rim profile seems to be more characteristic of the Persian period stratum (Lawlor 1991: figs. 3.14:8; 3.25:24-25; 1997: fig. 3.17:6, 9; 2002: fig. 3.18:6; Low 1991: fig. 8.21:22-23) rather than the Late Iron II or Iron II/Persian period stratum (Low 1997: fig. 7.16:12-13,

23). The rims also can be short (Lawlor 1997: fig. 3.17:4-5) or longer (Lawlor 1991: fig. 3.25:24-25) or almost hooked (Low 1997: fig. 7.16:23) with knobs on the exterior part of the rim.

Most downturned lips on the pendant rim are flat, although they may be slightly rounded. A variant lip is a “stepped” lip (Low 1997: fig. 7.16:13; see also Herr 1989: fig. 19.9:25). This rim has a groove on the lower portion of the rim and is found in the Iron II/Persian strata. No pendant rims with a grooved lip were found in Persian layers.

Only one whole vessel was discovered possessing a step-cut base (Low 1991: fig. 8.21:22). The wall profiles of the shards, however, indicate that the flattened-to-hooked rims seem to occur more often on rather shallow bowls with carination.

The third category of outcurving rim at Tall al-‘Umayri is characterized by a flattened or slightly rounded profile. The flattened, everted rim profiles coming from the Iron II/Persian strata (Berge and Willis 2002: figs. 5.20:12; 5.21:1; D. R. Clark 2002: fig. 4.43:5; Low 1997: fig. 7.16:18-20, 22) possess mostly a short and angular profile. The exception is an almost S-shaped rim with a sharply angled flat profile (Lawlor 2000: fig. 3.30:8). The Persian period examples are more numerous (Berge and Willis 2002: fig. 5.13:6, 8; D. R. Clark 2002: fig. 4.45:14; Lawlor 1991: fig. 3.13:7-8; 1997: figs. 3.16:29-32; 3.17:1-5; 2000: fig. 3.33:13; 2002: figs. 3.18:2-5; 3.19:6-11; Low 1991: fig. 8.21:24). Similar to the Iron II/Persian period shards, the Persian period shards are typically angular in profile. However, several examples appear to be more horizontal (D. R. Clark 2002: fig. 4.45:14; Lawlor 2002: fig. 3.18:3, 5). These do not appear in the Iron II/Persian layers. The Persian period rims also seem longer, as fewer short profiles are attested.

Ware and core colors do not differ between flaring, pendant, and flattened rims or between Persian period and Iron II/Persian period forms. Colors of the vessel fabric include black, pink, red (red, light red, or weak red), light reddish brown, reddish yellow, pinkish white, and gray (gray, light gray, pinkish gray, or dark gray). Core colors are dominantly gray (gray, dark gray, pinkish gray, or light gray) but also may be black, pink, red (red, pale red, or light red), reddish yellow, or light reddish brown.

Surface treatment on any of the rim categories consists of design burnish, light to heavy wheel burnish, and light to medium slip in the colors of gray (dark gray, pinkish gray, dark reddish gray, or very dark gray), black, red (red, light red, or weak red), reddish yellow, brown (light reddish brown or light brown), and pink and is usually limited to the rims. Decoration includes black or gray burnishing and ridging, and incising. A unique decorative feature of the Persian period pottery is grooving on the exterior rim (Lawlor 1991: fig. 3.13:8; 1997: figs. 3.16:29; 3.17:3), appearing only on angular rim profiles. Finger and tool impressions were also found on the walls. Black burnish seems to be a characteristic feature of Persian period vessels, while also showing up on Iron II/Persian period shards (Herr 2005).



### **Straight, Vertical Simple Rims**

The third main category of bowls found at Tall al-‘Umayri possesses a vertical rim inflection and simple rim profile. These rims are divided into three types according to the sidewall profiles. The first type is bowls with an upright wall, producing a hemispherical profile; the second type is bowls with an inward leaning wall, producing a globular or sharply curving wall profile; and the third type is bowls with an outward leaning wall, producing a V-shaped profile (Table 7).

The strata at Tall al-‘Umayri contain many bowls possessing a simple rim with a vertical, upright wall. The resulting hemispherical wall profile can be found in the Iron II/Persian period (Lawlor 2000: figs. 3.29:28-29; 3.30:2-5). The Persian period layers yielded many more examples (Lawlor 1991: figs. 3.13:12-13; 3.14:12-16, 18, 21-27, 31; 3.25:22-23; 1997: figs. 3.16:13; 3.17:16, 18; 2000: fig. 3.33:1, 3-4; 2002: fig. 3.19:4-5; Low 1991: fig. 8.21:11, 14-15). A more vertical wall is even more distinctive of Persian period forms (Lawlor 1991: fig. 3.14:21-27; 1997: fig. 3.17:18; see also Herr 1995: 618; 1997: 245) as there seems to be a trend toward more upright forms in the Persian period. A unique vessel with this type of wall profile possesses a much inverted, angular rim profile on top of an upright sidewall (Lawlor 1997: fig. 3.17:15; see also Herr 1989: fig. 19.16:18, 20).

TABLE 7

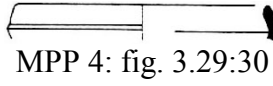
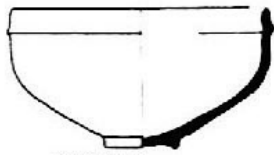
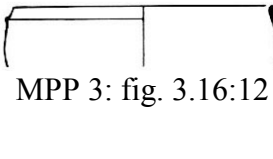
BOWLS WITH SIMPLE RIM WALL PROFILES

Period	Hemispherical Profile	Globular Profile	V-shaped Profile
Iron II/ Persian	 MPP 4: fig. 3.29:28	 MPP 4: fig. 3.29:30	Not found
Persian	 MPP 5: fig. 3.19:5	 MPP 3: fig. 3.16:12	 MPP 5: fig. 3.18:23

*Note.* Drawing is not to scale.

The hemispherical wall on this bowl may have two different profiles. The first profile is sharply carinated (e.g., Lawlor 1991: fig. 3.14:18; 1991: fig. 3.17:16; 2000: fig. 3.30:2) while the second is more rounded (e.g., Lawlor 1991: fig. 3.14:26; 2002: fig. 3.19:4). Both profiles are found in the Iron II/Persian and Persian periods.

The second type of wall profile of simple rims is an inward leaning wall, giving a globular shape to the vessel. This type of bowl is found in the Iron II/Persian period (D. R. Clark 2002: figs. 4.43:4; 4.51:10-11, 14; Lawlor 2000: fig. 3.29:30; Low 1997: fig. 7.16:11) as well as the Persian period (Berge and Willis 2002: fig. 5.13:9-10; Lawlor 1991: figs. 3.13:11; 3.14:17; 1997: figs. 3.16:12, 14; 3.17:15; Low 1991: fig. 8.21:12-13). The lip can be thinned or rounded (giving this type of vessel the name “holemouth bowl”). Occasionally the rims may be slightly thickened (e.g., Clark 2002: fig. 4.51:14; see also Herr 1989: fig. 19.9:3-9) but this is probably more characteristic of the later Iron II period than the Persian period as the Iron II/Persian period strata has these rims but the Persian period strata do not.

The third type of simple rim found at Tall al-‘Umayri is relatively deep with a V-shaped wall profile. No V-shaped bowls were found in Iron II/Persian period strata at the site. The Persian period strata yielded several examples of this vessel (Berge and Willis 2002: fig. 5.13:11; Lawlor 1991: figs. 3.13:14; 3.14:20; 1997: figs. 3.12:7; 3.22:22; 2000: fig. 3.33: 2, 5, 14, 21; 2002: figs. 3.18:22-23; 3.19:1-3). Several unique forms can be found among the Persian period pieces. One bowl (Lawlor 1997: fig. 3.22:22), called a “mini-bowl,” possesses extremely thick ware with a flat base. Five vessels (Lawlor 2002: figs. 3.18:22-23; 3.19:1-3) can be stacked inside of each other (Herr 2002b: 149). Small handles appear on another bowl (Lawlor 1991: fig. 3.14:20).

Ware colors include pink, red (red, light red, or weak red), reddish yellow, brown (brown, light brown, light reddish brown, reddish brown, pale brown, or very pale brown), gray (gray or pinkish gray), and white. Core colors include pink, red (red, pale red, or light red), light reddish brown, and gray (gray, pinkish gray, dark gray, reddish gray, or light gray). A note should be made about the mold-made vessel (Lawlor 1997: fig. 3.16:32). Vessels vary in size, some almost reaching the size of kraters.

Surface treatments include design burnish, light to heavy wheel burnish, and light to heavy slip in the colors of white, red (red, light red, weak red, or dusky red), reddish yellow, pink, brown (brown or light reddish brown), and gray (gray, dark pinkish gray, reddish gray, dark reddish gray, very dark gray, or light gray). Decorations include incising, appliqué, gray burnish, and paint (brown, reddish brown to dark reddish brown, dark gray to very dark gray, pinkish white, or white). Paint was applied to more inward leaning vessels (D. R. Clark 2002: figs. 4.34:4; 4.51:10-11, 14; Low 1991: fig. 8.21:13) than the other two wall types. Knobs appear on the rim of one vessel (Lawlor 1991: fig. 3.14:22).

The most common decoration is a small exterior ridge usually just below the rim along the sidewall. Ridging can be seen on all three types of sidewalls. On hemispherical bowls, however, ridging appears only on rounded sidewalls and not on carinated walls. It also appears on vessels with inward leaning, globular walls and on all bowls dating to the Iron II/Persian period and on a few Persian period bowls. The ridge seems to become less defined later in the Persian period. Vessels with a ridge below the rim are almost exclusively a Transjordanian form, not being found in Cisjordan. The vessel is attested to throughout Transjordan. Instead of a ridge, a groove may be incised below the rim

(Lawlor 1991: fig. 3.14:26-27) or lower on the sidewall (Lawlor 1997: fig. 3.17:18).





Grooving appears on Persian period bowls only with hemispherical sidewalls.

### Flattened Rims

The fourth category of rim profile on bowls at Tall al-‘Umayri is flattened rims. Flattened rims are common throughout the Iron II/Persian and Persian periods. The rims fall into two categories (Table 8). The first category is a rim profile inverting about 90° from the body wall and may be horizontal or angular upward. These rims are very similar to interior thickened rims with the main difference being a flattened lip (see below). The second category of rim profiles is a T-shaped rim that is thickened on the exterior and interior but has a flat lip. The T-shaped rims (also called “hammer-head”) should not be confused with symmetrically thickened rims (see below). The difference is that the flattened version has a flat lip with pronounced exterior and interior thickening at interior and exterior inflection points, resulting in an obvious T-shape profile.

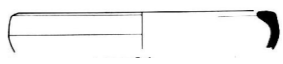
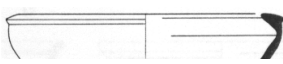
TABLE 8

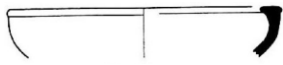
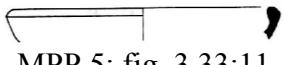
BOWLS WITH FLATTENED RIM PROFILES

Period	90° Horizontal Profile	90° Upward Angle Profile	T-shaped Profile
Iron II/ Persian	 MPP 1: fig. 19.8:24	 MPP 4: fig. 3.30:6	 MPP 3: fig. 7.16:15
Persian	 MPP 4: fig. 3.33:9	 MPP 5: fig. 3.33:11	 MPP 3: fig. 3.16:21

*Note.* Drawing is not to scale.



The flattened, horizontal rim profile appears to be more numerous in the Persian period as opposed to the Iron II/Persian period. Only two examples may tentatively be assigned the date of Iron II/Persian period (Herr 1989: fig. 19.8:24-25). The Persian period yielded more examples (Lawlor 1991: figs. 3.13:17-19, 24, 28; 3.14:1-4; 2000: fig. 3.33:7, 9-10; see also Herr 1989: fig. 19.15:21). Several shards possess a more rounded lip than flat (e.g., Lawlor 1991: fig. 3.14:1-2). It also should be noted that flattened, horizontal rim profiles may appear similar to a T-shaped profile if a slight exterior thickening exists (e.g., Lawlor 1991: fig. 3.14:3-4; 2000: fig. 3.33:9). Persian period examples also may have ridging below the rim (Lawlor 2000: fig. 3.33:10; see also Herr 1989: fig. 19.15:21), knobs along the rim (Lawlor 1991: fig. 3.14:3-4), or both (Lawlor 1991: fig. 3.13:28). Knobs also are found on one of the possible Iron II/Persian period shards (Herr 1989: fig. 19.8:25).

The flattened, angular rim profile differs from the horizontal rim profile due to its slight to extreme angle inflecting upward from the sidewall of the vessel body. This profile occurs in both the Iron II/Persian (Lawlor 2000: fig. 3.30:6; Low 1997: fig. 7.16:6-8; see also Herr 1989: fig. 19.8:23) and Persian periods (Berge and Willis 2002: figs. 5.13:7, 16; 5.14:2; Lawlor 1991: fig. 3.13:21-23, 25-27, 29; 1997: figs. 3.16:22; 3.17:14; 2000: fig. 3.33:8, 11; 2002: fig. 3.19:17; Low 1991: fig. 8.21:30; see also Herr 1989: fig. 19.15:20). Based on the findings from Tall al-‘Umayri, angular rim profiles began in the Iron II period (e.g., Low 1991: figs. 8.8:8; 8.9:8; 8.16:7-8; 1997: fig. 7.16:6, 8), but became more prominent in the Persian period. Although the horizontal rim seemed to be more popular during the Iron II/Persian period than the angular rim (Herr

1989: 305, 308), the angular rim now appears to be more common than the horizontal rim in that period.

As with horizontal rim profiles, angular rims occasionally have a ridge below the rim. The ridge appears on both Iron II/Persian period shards (Low 1997: fig. 7.16:7-8) and Persian period shards (Lawlor 1997: fig. 3.16:22; see also Herr 1989: fig. 19.15:20). Knobs are infrequent, found only on one shard (Lawlor 1997: fig. 3.16:22).

The T-shaped rim profile differs from the first two types of flattened rims due to thickening. It contains thickening on both the interior and exterior of the rim, although it usually is very slight. This rim began in the Iron II period (e.g., D. R. Clark 1991: fig. 4.7:26; Low 1991: figs. 8.8:21; 8.16:32), with very few Iron II/Persian period examples (Low 1997: fig. 7.16:15; see also Herr 1989: figs. 19.8:26; 19.10:5) but it is a little more prominent in the Persian period (Lawlor 1991: fig. 3.13:15, 20; 1997: fig. 3.16:21, 23; Low 1991: fig. 8.21:31-32; see also Herr 1989: fig. 19.16:15). Lips are usually flat but may be somewhat rounded (e.g., Lawlor 1991: fig. 3.13:15; Low 1991: figs. 8.16:32; 8.21:32). Grooving on the lip may possibly also occur (e.g., Herr 1989: figs. 19.10:5; 19.16:15), but not enough examples were found for a definite determination.

Ware colors for flattened rims include red (red or light red), reddish yellow, gray (gray, pinkish gray, or dark gray), brown (brown, very pale brown, light yellowish brown, light reddish brown, or pale brown), and pink. Core colors include pink, gray (gray, pinkish gray, or light gray), and light reddish brown. As no whole forms were found (or were published), the exact wall profile is uncertain. However, from the published shards at 'Umayri, it seems that the wall profile was ordinarily biconical in nature, almost being carinated. The depth of the bowls was generally medium.

Surface treatment includes medium to heavy wheel burnish, design burnish and light to medium slip in colors of pink, red (red or light red), reddish yellow, gray (gray, dark gray, pinkish gray, or reddish gray), and brown (very pale brown, light reddish brown, reddish brown, or dark grayish brown). Decoration includes incising and ridging as well as the appliqué of knobs below the rim.





### **Thickened Rims**

Thickened rims from Tall al-‘Umayri are quite numerous. The rims may be divided into three types of exterior thickening, interior thickening, and symmetrical thickening (Table 9). Some confusion may result as interior thickened rims may look very similar to angular flattened rims mentioned above and that symmetrical thickened rims look very similar to the T-shaped rim. Oftentimes the distinction between an interior thickened rim and an angular flattened rim or a symmetrical thickened rim and a T-shaped rim is subjective and depends on the ceramicist or archaeologist. These types or the assignment of certain shards to them should not be considered hard and fast, but are used here for the sake of discussion and organization. Besides this confusion between types, confusion may result within the overall type of thickened rims as well. Deciding whether a rim is externally, internally, or symmetrically thickened is as subjective as deciding whether it is, for example, symmetrically thickened or T-shaped.

Rims with exterior thickening are common in the Iron II/Persian period but seem to grow in popularity in the Persian period. Some examples exist from the Iron II period (e.g., Low 1991: fig. 8.16:30-31, 33; 1997: fig. 7.16:7), but this rim peaked during the Persian period (Berge and Willis 2002: fig. 5.13:12; Lawlor 1991: fig. 3.14:5-7, 10-11, 28-30; 1997: figs. 3.16:20, 24-26; 3.17:12; 3.22:20; 2002: fig. 3.18:7; Low 1991: fig.

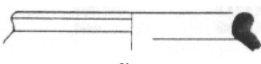
8.21:26, 28-29), with a few examples from the transitional Iron II/Persian period (Lawlor 2000: fig. 3.29:38; Low 1997: fig. 7.16:16; see also, Herr 1989: fig. 19.9:13-14). The rims generally have a rounded lip (e.g., Lawlor 1997: fig. 3.16:20; 2000: fig. 3.29:38; 2002: fig. 5.13:12) but it may be flat (e.g., Lawlor 2002: fig. 3.18:7; Low 1997: fig. 7.16:16; see also Herr 1989: fig. 19.9:13-14). The flat rim profiles seem to appear more during the Persian period than during the Iron II/Persian period, but due to the low numbers of flat rims with exterior thickening found at Tall al-‘Umayri, a definitive comparison is not currently possible.

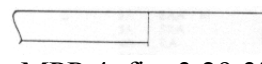
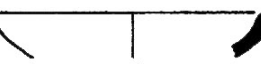
TABLE 9  
BOWLS WITH THICKENED RIM PROFILES

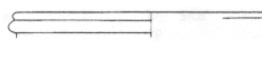
Period	Exterior Thickening Profile	Interior Thickening Profile	Symmetrical Thickening Profile
Iron II/ Persian	 MPP 4: fig. 3.29:38	 MPP 4: fig. 3.29:36	 MPP 4: fig. 3.29:37
Persian	 MPP 3: fig. 3.17:12	 MPP 3: fig. 3.16:19	 MPP 5: fig. 3.19:14

*Note.* Drawing is not to scale.

Generally, the exterior thickened rims are inflected slightly inward but may flare outward (Berge and Willis 2002: fig. 5.13:12; Lawlor 1997: fig. 3.17:12; 2002: fig. 3.18:7; see also Herr 1989: fig. 19.16:12). This flaring is more common during the Persian period than during the Iron II/Persian period. The thickening of the rims is commonly prominent but may also be subtle (Lawlor 1991: fig. 3.14:7; 1997: fig.

3.16:24-26). A groove may appear just below the rim but appears prominently in the Persian period (e.g., Lawlor 1991: fig. 3.14:6, 10-11; 1997: fig. 3.16:20). The long, thickened rim (Herr 1989: fig. 19.16:12) has yet to be found in the Iron II/Persian period stratum (Herr 1989: 308).

In addition to grooving, exterior thickened rims may be decorated with ridging or a bulb, both located below the thickened rim. The ridging gives the bowl the appearance of possessing a neck. These “necked” bowls are infrequent in the Iron II/Persian period and have a rather slight ridge (e.g., Lawlor 2000: fig. 3.29:38; Low 1997: fig. 7.16:16). The necks flare out from the sidewall of the vessel. Ridging continued and became more prominent during the Persian period (Low 1991: fig. 8.21:26, 28-29), giving the bowls a more upright, vertical neck than during the preceding period. The bulb does not appear on Iron II/Persian period thickened rims, but several examples were found dating to the Persian period (Lawlor 1997: fig. 3.14: 28-30).

Rims with interior thickening are by far the least common of the three types of thickened rim profiles at Tall al-‘Umayri. The Iron II/Persian period examples (Lawlor 2000: figs. 3.29:36; 3.30:7) are quite different. The latter rim possesses a rounded lip but an everted neck due to a slight ridge located just below the thickening. The former piece has a flat rim, an exterior groove below the thickening, and a sharply inverted rim profile. The characteristics of these two shards continue into the Persian period. The rounded lip profile is common (Lawlor 1991: fig. 3.14:32; 1997: figs. 3.16:19; 3.17:13) but flat lip profiles also show up (Lawlor 1991: figs. 3.13:30; 3.14:19). These last two rims possess the sharply inverted rim profile.

Rims with symmetrical thickening seem to increase from the Iron II/Persian period into the Persian period at Tall al-‘Umayri. Few are found in the Iron II period (e.g., Low 1991: figs. 8.8:20; 8.16:29; 1997: fig. 7.16:9). Only four examples date to the Iron II/Persian period (Lawlor 2000: figs. 3.29:31, 37; 3.30:1; Berge and Willis 2002: fig. 5.21:2). Many more rims date to the Persian period (D. R. Clark 2000: fig. 4.36:8; 2002: fig. 4.45:20-21; Lawlor 1991: fig. 3.14:9; 1997: figs. 3.16:28; 3.17:10-11; 2000: fig. 3.33:12; 2002: figs. 3.18:8; 3.19:14-16; Low 1991: fig. 8.21:27; 1997: fig. 7.16:9-10).

Lip profiles on symmetrically thickened rims may be either slightly widened and flat or rounded. Flat rims seem to be more common in the Iron II/Persian period (Berge and Willis 2002: fig. 5.21:2; Lawlor 2000: fig. 3.29:31 see also Herr 1989: fig. 19.9:10-11) than the rounded lip (Lawlor 2000: fig. 3.29:37). During the Persian period, lip profiles continue to be flattened (e.g., Lawlor 1997: fig. 3.17:10; Low 1997: fig. 7.16:10) or rounded to bulbous (e.g., Lawlor 2002: fig. 3.19:15-16). Slightly widened rims have parallels from the Jordan Valley during the eighth century B.C. as well as similar forms throughout Palestine in the ninth to eighth centuries B.C. (Herr 1989: 305).

This rim type may have a very slight groove placed just below the thickened rim at the inflection point, creating the look of a neck. One shard with a groove was found from the Iron II/Persian period (Lawlor 2000: fig. 3.29:37) while several examples came from the Persian period (D. R. Clark 2002: fig. 4.45:21; Lawlor 2000: fig. 3.33:12; Low 1991: fig. 8.21:27). The Persian period necks tend to be upright in stance, but one was everted (D. R. Clark 2002: fig. 4.45:21) in addition to the Iron II/Persian period example. Grooving may also occur below the inflection point (D. R. Clark 2002: fig. 4.45:20; Lawlor 1991: fig. 3.14:9; 1997: fig. 3.17:10-11).

Besides grooving, symmetrically thickened rims are commonly decorated with bulbous ridge of clay around the exterior wall of the vessel just below the rim. This bulb is rather common in the Persian period (D. R. Clark 2000: fig. 4.36:8; 2002: fig. 4.45:20; Lawlor 1991: fig. 3.14:9; 1997: fig. 3.16:28; 2002: figs. 3.18:8; 3.19:14-16; Low 1997: fig. 7.16:9-10; see also Herr 1989: figs. 19.10:7; 19.15:22) while one Iron II/Period rim shard with a bulb was also uncovered (Lawlor 2000: fig. 3.30:1). Bulbs become very pronounced in the Persian period (e.g., Lawlor 1991: fig. 3.14:9; 2002: fig. 3.19:14-15; Low 1997: fig. 7.16:9-10).

No whole vessels were found or published so wall profiles are uncertain. Most of the wall profiles seem to be biconical (e.g., Lawlor 1991: fig. 3.14:6, 11, 19, 28) with a few instances of those with a V-shape (e.g., Berge and Willis 2002: fig. 5.13:12; Lawlor 2002: fig. 3.18:7; see also Herr 1989: fig. 19.16:12), carinated (e.g., Lawlor 1997: fig. 3.16:24-25), or rounded to globular (e.g., D. R. Clark 2002: fig. 4.45:20-21) sidewalls.

Ware colors include red (red, yellowish red, light red, or pale red), reddish yellow, pink, pinkish white, gray (gray, pinkish gray, dark gray, or very dark gray), black, and brown (very pale brown, light reddish brown, or dark grayish brown). Core colors include gray (gray, light gray, pinkish gray, or dark gray), pink, red (red or pale red), and reddish yellow.

Surface treatments include light to heavy wheel burnish, design burnish, and light to medium slip in colors of pink, red (red, dusky red, reddish yellow, yellowish red, or light red), gray (gray, pinkish gray, light gray, dark gray, or very dark gray), black, and brown (pale brown or light reddish brown). Decoration includes appliqué (bulb), ridging, incising, rouletting, finger impressions, and black burnish.

## Miscellaneous Bowl Forms

Several assorted bowl forms of the Persian period occur at Tall al-‘Umayri. These miscellaneous forms include basins, plates and platters, cups and mugs, kraters, cook pots, and mortaria.

### Basins

The rims of basins vary (Table 10). Most basin rims originated in Persian period strata, although a few came from an Iron II/Persian period context. The most common rim profile is flattened and everted (Lawlor 1997: fig. 3.15:24, 26; Low 1991: fig. 8.19:18, 20-22; see also Herr 1989: figs. 19.7:1; 19.13:1-2). The rims seem to be more common in the Persian period than in the Iron II/Persian period, with Iron II/Persian period rims tending to evert upward, while Persian period rims seem to evert downward or horizontal (Herr 1989: 307). Grooves appear on top of the flattened rims in both periods. A single groove may also appear on the lip (very edge of the rim) (Lawlor 1997: fig. 3.15:26; Low 1991: fig. 8.19:18). A variant of this rim is a thinner rim that slopes downward (Low 1991: fig. 8.19:21-22). It is not found in the Persian period strata but may be a precursor to those Persian period rims that slope downward but are thicker (Lawlor 1997: fig. 3.15:24, 26).

A lesser common rim profile is simpler than the previous rim profile but may be thickened (Lawlor 1997: fig. 3.15:25; Low 1991: fig. 8.19:23-24; see also Herr 1989: fig. 19.13:4). The Iron II/Persian period rims tend to be more inverted than the Persian period rims.

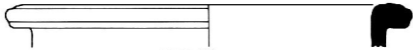
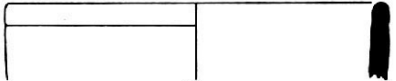

TABLE 10  
BASIN RIM PROFILES

Period	Flattened and Everted Profile	Thickened
Iron II/ Persian	Not found	Not found
Persian	 MPP 3: fig. 3.15:26	 MPP 3: fig. 3.15:25

*Note.* Drawing is not to scale.

A possible variant rim profile of the Persian period is a T-shaped rim with two grooves on the lip and slopes everted downward (Herr 1989: fig. 19.13:3). This vessel also has deep grooves along the exterior of the body wall. An additional possible variant (Herr 1989: fig. 19.3:4) has very thick ware with a slightly out-turned rim and squared lip. It seems to be limited to the Ammonite plateau (Herr 1989: 308).

Ware colors include pink, reddish yellow, pink, and light red (only one). Core colors include gray (gray, dark gray, or very dark gray). The wall profiles of these basins seem to be cylindrical with a few that slope inward or outward. Only one whole vessel was found with a flat base. No Iron II/Persian period forms had handles, but two of the Persian period forms did. The handles extend from the rim or just below the rim to the middle of the wall. One set of handles is handmade (Herr 1989: fig. 19.13:2).

Surface treatments include only light to heavy slips of colors: white (white or pinkish white), brown (very pale brown or light reddish brown), and gray. Dominant slip

color is very pale brown. Generally, only the rim is slipped on the interior and exterior. There is no wheel burnish or decoration.



### Plates and platters

An uncommon specialized bowl type found at Tall al-‘Umayri is the plate and platter. A plate or platter has the function of serving, which is similar to that of most bowl types, but both are rather shallow with an increasing diameter, differentiating both of them from other types of bowls (Hendrix, Drey, and Storfjell 1996: 39). The main difference between a plate and platter is that a platter generally possesses a wider diameter. The differences between a plate or platter and a shallow bowl as well as between a plate and a platter are very subtle, and quite often the terms “plate” and “platter” are not used to label the ceramic shard. Instead, the shard may be termed “bowl.” Only shards that were named “plate” or “platter” are discussed here since very few whole forms have been found and depth of the bowl is needed to determine its shallowness. Other shallow bowls have been discussed above under the various bowl types.

Although plates and platters are not common at Tall al-‘Umayri, two styles of rim profiles can be found (Table 11). The first style is a squared (almost flat) rim. Several squared shards exist from the Persian period (Herr 1989: fig. 19.16:21-22; Lawlor 1991: fig. 3.15:1, 3-5; 1997: fig. 3.17:19-21; 2000: fig. 3.30:9; 2002: fig. 3.19:29). Squared rims usually are found at the end of an everted flaring sidewall. The sidewall may be fairly straight (e.g., Lawlor 1997: fig. 3.17:19; 2000: fig. 3.30:9) or with a slight bend (Lawlor 1991: fig. 3.15:3-5). The bend in the sidewall forces the rim to almost appear horizontal in profile.

No squared rims from plates have been found (and published) from Iron II/Persian period strata. This absence of Iron II/Persian period plates with squared rims may simply be due to the low number of plate shards that have been found or that they were labeled “bowl” and not “plate.” The conclusion that squared rimmed plates did not occur in the Iron II/Persian period is at best tenuous until more plates have been found and identified as such.

TABLE 11  
PLATES AND PLATTERS RIM PROFILES

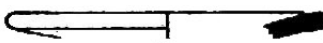
Period	Squared Profile	Flaring, Simple Profile
Iron II/Persian	Not found	 MPP 5: fig. 3.6:14
Persian	 MPP 4: fig. 3.30:9	 MPP 3: fig. 3.17:23

*Note.* Drawing is not to scale.

The second type of rim profile is a flaring simple (rounded) rim. This rim is also common in the Persian period (D. R. Clark 1991: fig. 4.9:11; Lawlor 1991: fig. 3.15:1-2, 6; 1997: fig. 3.17:22-23; Low 1991: fig. 8.22:1-2). Several Iron II/Persian period shards do exist (Lawlor 2000: fig. 3.30:10; 2002: fig. 3.6:14; see also Herr 1989: fig. 19.10:16-17). Shards of both periods possess a simple rim ending an everted flaring sidewall. As with the sidewalls of squared rims, a slight bend may be present. One possible unique feature is a groove on the interior of the rim (fig. 19.10:16-17), although this groove is difficult to identify from pottery drawings.

Two other uncommon types of rim profiles have been found at Tall al-‘Umayri. These rim profiles have been found only on two individual shards and so may have been mistakenly termed “plate” instead of “bowl” due to their shallow stance. The first rim profile (Lawlor 1991: fig. 3.14:33) possesses a 90° rim angling up from the sidewall of the body. Many bowls also feature this rim profile (see “Flattened, angular, inverted” rim profiles above). The second “unique” rim profile (Lawlor 2002: fig. 3.19:30) is flaring out and turned slightly downward. Again, many bowls possess this rim profile (see “Outcurving, everted” rim profiles above).

Platters, or “platter bowls,” are rare at Tall al-‘Umayri. One example (Lawlor 2002: fig. 3.19:20) may be a platter due to its wide diameter and shallow depth. However, platters are not found in the Iron II/Persian period stratum and may be intrusive (Herr 1989: 308).

Ware colors varied on plates and platters. Square rims had mostly pink but also gray (gray or reddish gray) and red (red or light red) with mostly gray (gray, pinkish gray, or light gray), pink, and pale red cores. Surface treatment was mostly on the interior surface but also on both exterior and interior and included light to heavy wheel burnish, design burnish, and light to medium slip in tones of red (red or light red), brown (reddish brown or light reddish brown), and gray (dark gray or reddish gray).

Flaring simple rims had ware colors of pink, light reddish brown, red (red or pale red), and gray. Core colors were mostly gray (gray, light gray, or dark gray) but also pink. Surface treatments on the rim included medium to heavy wheel burnish and light to heavy slip in colors of pink, red (red or light red), reddish yellow, dark reddish gray, or light reddish brown. Decoration includes incising.

Grooved rims were found only in the Iron II/Persian period. Ware colors include very pale brown, pink, or pinkish gray. Core colors were only gray. Surface treatment included wheel burnish and light to medium slip on the rims in colors of brown (very pale brown or dark grayish brown), red, and reddish yellow. Decoration included incising.

#### Cups and mugs

A specialized type of bowl, primarily used for drinking, is a cup. Cups are usually characterized by possessing a very small diameter and a depth that is almost equal to its diameter (Hendrix, Drey, and Storffjell 1996: 38). Bowls with a very small diameter may also be termed “mini-bowl,” “cup bowl,” or “mug” but also just “bowl” because the term “cup” denotes function (drinking), which may have escaped the judgment of the ceramicist. This bowl type is uncommon at Tall al-‘Umayri and so comparisons between the Iron II/Persian period and the Persian period are not possible.

Cups generally possess a unique wall profile. A high inverting ridge extends from a slightly everting sidewall, forcing the rim profile inward and partially closing the mouth opening. The ridge may be almost horizontal or turned up at a 45° angle. This cup is found in the Iron II/Persian period (D. R. Clark 1997: fig. 4.32:16; see also Herr 1989: fig. 19.10:9) but also in the Persian period (Herr 1989: fig. 19.16:18, 20), although the Persian period examples have not been found in other Persian period contexts at Tall al-‘Umayri and so may be intrusive from the previous Iron II/Persian period. Cups may have one loop handle extending from the ridge extension to the lower on the sidewall (D. R. Clark 1997: fig. 4.32:16) as well as a tripod base (D. R. Clark 1997: fig. 4.32:17).

A single shard termed “cup” from Tall al-‘Umayri is slightly different from the other cups. This cup (Lawlor 1991: fig. 3.15:7) is from the Persian period and possesses a

similar high ridge extending inward from the sidewall. The ridge, however, extends almost vertical instead of horizontal or at a 45° angle.

A possible variant form of a cup has an outcurving, flattened rim with knobs as legs, which may have functioned as a chalice (Herr 1989: fig. 19.10:2). Two further examples of variant forms have been termed “chalice bowls” due to the simple, flaring rims (Herr 1989: figs. 19.10:1; 19.16:8) and another one as a “goblet” (Herr 1989: fig. 19.10:3).

Specialized bowls, called “mugs,” have been uncovered from strata of both time periods. The Persian period examples (Herr 1989: fig. 19.16:23; Lawlor 1991: fig. 3.15:8-9) have an inflected sidewall creating a vertical neck on top of a globular body. Only the Iron II/Persian period example (Herr 1989: fig. 19.10:10) has a loop handle from the rim to lower on the sidewall.

Ware colors include dominantly pink with red (red or light red), reddish yellow, and dark gray. Core colors were sometimes like the ware colors but mostly were gray. Surface treatments were light to medium slip in colors of pinkish gray or light red. Decoration included ridging and incising on the neck or rim and paint in the color of reddish gray.

## Kraters

Another specialized bowl form is the krater (also spelled “crater”). A krater is a large bowl “with a 'S'-curved wall profile” (Hendrix, Drey, and Storfjell 1996: 39). This vessel was used for mixing wine and water, but the function may not be necessarily tied to the name, as a vessel may be called a krater regardless of its function.

Primarily two categories of kraters are found at Tall al-‘Umayri: holemouth kraters and closed kraters. Holemouth kraters occur in several different types. One type has an elongated, inverted thickened rim with examples coming from the Iron II/Persian (Berge and Willis 2002: fig. 5.20:9; see also Herr 1989: figs. 19.7:2-4) and Persian (D. R. Clark 2002: figs. 4.43:16; 4.44:1, 3; Lawlor 1991: fig. 3.12:23-25, 27, 31; 1997: figs. 3.15:27, 29; 3.22:14; 2002: figs. 3.6:19; 3.18:20, 21; Low 1991: figs. 8.19:25-26; 8.20:1-5; see also Herr 1989: fig. 19.13:5) periods (Table 12). It should be mentioned that the first Iron II/Persian period shard came from an unstratified context and so the elongated, thickened rim occurs primarily during the Persian period.

TABLE 12

HOLEMOUTH KRATERS WITH ELONGATED RIMS

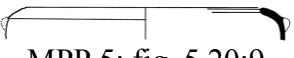
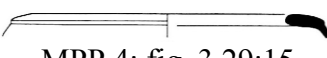
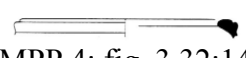
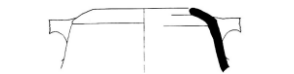
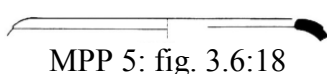
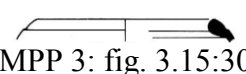
Period	Inverted Thickened Rim	External “Bump”	External Ridge Below Rim on Sidewall
Iron II/ Persian	 MPP 5: fig. 5.20:9	 MPP 4: fig. 3.29:15	 MPP 4: fig. 3.32:14
Persian	 MPP 5: fig. 3.18:21	 MPP 5: fig. 3.6:18	 MPP 3: fig. 3.15:30

*Note.* Drawing is not to scale.

Several variant types of the elongated rims exist. One type has an external “bump” which looks almost like a very short neck. Most examples come from the Persian period (Berge and Willis 2002: fig. 5.13:5; D. R. Clark 2002: fig. 4.44:4; Lawlor 1991: fig. 3.12:26, 28-29; 1997: figs. 3.12:4; 3.15:31; 2000: fig. 3.32:13; 2002: fig. 3.6:18; see

also Herr 1989: fig. 19.13:7-9) although two Iron II/Persian period shards were published (D. R. Clark 1997: fig. 4.32:10; Lawlor 2000: fig. 3.29:15). Another variant of the holemouth krater with elongated thickened rim has a single external ridge below the rim on the sidewall. This type of rim is common in the Persian period (Lawlor 1997: fig. 3.15:28, 30; Low 1991: fig. 8.20:6-16; see also Herr 1989: figs. 19.13:6; 19.14:2-3) but also found in the Iron II/Persian period (Lawlor 2000: figs. 3.32:14; fig. 3.29:16). This rim may have a thinned lip or a flat lip. A variant of this type has more than one external ridge or possibly incising (Lawlor 1997: fig. 3.12:5; see also Herr 1989: figs. 19.7:5-6; 19.14:1). This variant may have two handles starting immediately below the ridging. Elongated thickened rims seem to have developed through the Iron II/Persian period into the Persian period. The rim may be also found on jars where the sidewalls are more vertical. It has parallels frequent in Transjordan and Israel.



A second type of holemouth krater has a thickened rim profile (Table 13). These rims may be short and are found only in a Persian period context (Lawlor 1991: fig. 3.12:30, 32-35; 1997: figs. 3.15:32-34; 3.22:15; see also Herr 1989: fig. 19.14:5). Some of these short rims also may have an external thickening that looks like a small neck (Lawlor 1991: fig. 3.12:30, 32; 1997: fig. 3.15:32) or incising on the lip (Lawlor 1991: fig. 3.12:32). A variant of this thickened rim has a triangular profile that protrudes up from the sidewall and tends to point at an inner angle. Examples of this triangular rim may be found during the Iron II/Persian period (Berge and Willis 2002: fig. 5.20:10-11; see also Herr 1989: fig. 19.7:7-9) but also during the Persian period (Berge and Willis 2002: fig. 5.13:3-4; Lawlor 1991: fig. 3.13:1-3; 2000: fig. 3.32:15; see also Herr 1989: fig. 19.13:10). The ware of this variant form is thinner in the Persian period than in the



Iron II/Persian period and has a more angular rim. It is frequent at Tall al-‘Umayri but unattested elsewhere.

Most of the sidewalls of holemouth kraters are curved or globular. The holemouth krater probably began earlier than most forms (Herr 1997c: 245).

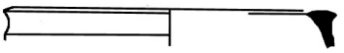
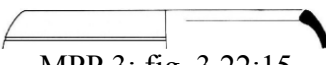
TABLE 13  
HOLEMOUTH KRATERS WITH THICKENED RIMS



Period	Thickened, Short Rim	Thickened, Triangular Rim
Iron II/Persian	Not found	 MPP 5: fig. 5.20:11
Persian	 MPP 3: fig. 3.22:15	 MPP 4: fig. 3.32:15

*Note.* Drawing is not to scale.

The second category of kraters is closed kraters (Tables 14 and 15). These kraters differ from holemouth kraters in that they possess a neck. The closed krater has several variant rim profiles. Both Iron II/Persian period (D. R. Clark 1997: fig. 4.32:11, 21; Lawlor 1991: fig. 3.13:4; Low 1991: fig. 8.20:17-18) and Persian period (D. R. Clark 1997: fig. 4.32:21; Lawlor 1997: fig. 3.16:1; 2000: fig. 3.32:12; see also Herr 1989: fig. 19.14:4, 6) shards have an externally thickened rim. Others, including Iron II/Persian period (D. R. Clark 1991: fig. 4.9:8) and possible Persian period (Herr 1989: fig. 19.14:7-8) examples, have a more vertical simple rim with external grooves on the neck and globular sidewalls. It should be noted that this thin-walled krater may be intrusive from lower levels (Herr 1989: 308).

In addition, other rims may possess an upright triangular and grooved rim. One Persian period shard was found (Lawlor 1991: fig. 3.13:5) but two possible Iron II/Persian period shards also should be mentioned (Herr 1989: fig. 19.7:10, 12). This rim probably is an earlier rim with parallels lacking except for an ungrooved version from an eighth century deposit at Tall as-Sa‘idiyah (Pritchard 1985: fig. 8:12). Another Iron II/Persian period shard (Herr 1989: fig. 19.7:11) has an upright neck with simple rim that is rare at Tall al-‘Umayri but similar to Persian period necked kraters (Herr 1995: 618; 1997: 245). One final variant from the Persian period has an everted and simple rim with no grooving (Lawlor 1997: fig. 3.22:16; 2002: fig. 3.6:17).

TABLE 14  
TYPES OF CLOSED KRATERS: SIMPLE RIMS

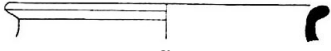
Period	Vertical Simple Rim with Grooves on Neck and Globular Sidewalls	Everted and Simple Rim with No Grooving
Iron II/Persian	 MPP 2: fig. 4.9:8	Not found
Persian	 MPP 1: fig. 19.14:7	 MPP 5: fig. 3.6:17



*Note.* Drawing is not to scale.

Ware colors include pink, gray (gray, light gray, dark gray, pinkish gray, or reddish gray), red (red or light red), reddish yellow, black, and brown (brown, light reddish brown, grayish brown, or light brown). Core colors include primarily gray (gray, light gray, or dark gray) with only one example of pinkish gray.

Most of the shards had no surface treatment or decoration. When surface treatments do occur, they include light to heavy wheel burnish, light to heavy slip, smoothing, and design. Colors include pink, red (light red, weak red, or pale red), brown (very pale brown or light reddish brown), gray (gray, dark gray, pinkish gray, reddish gray, light brownish gray, or dark reddish gray), white (white or pinkish white), reddish yellow, and black. Decoration includes appliqué, ridging, incising, finger impressions, and paint (dark gray, dark reddish gray, reddish brown, white, and pinkish white).

TABLE 15

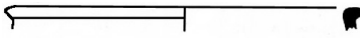
TYPES OF CLOSED KRATERS: OTHER RIMS

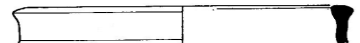
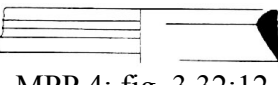
Period	Upright Triangular and Grooved Rim	Externally Thickened Rim
Iron II/Persian	 MPP 1: fig. 19.7:12	 MPP 2: fig. 3.13:4
Persian	 MPP 2: fig. 3.13:5	 MPP 4: fig. 3.32:12

*Note.* Drawing is not to scale.

### Cooking pots

A specialized form of the bowl is the cooking, or cook, pot. The general form of the cooking pot is of a bowl, generally with a rounded base. The function of the vessel distinguishes it from being a common bowl. Whereas a bowl is used for serving, the cooking pot is used for food preparation. At Tall al-‘Umayri, cooking pots can be divided into two types. The first type has a thickened and ridged rim while the second type possesses a bulbous rim (Table 16).

TABLE 16  
TYPES OF COOKING POTS

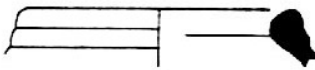
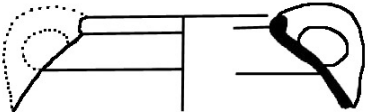
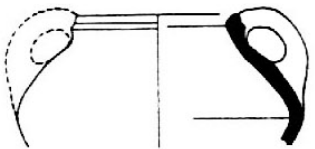
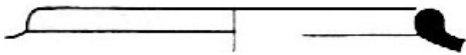
Period	Thickened and Ridged Rim	Bulbous Rim
Iron II/ Persian	 MPP 4: fig. 3.30:13	 MPP 5: fig. 4.43:2
Persian	 MPP 4: fig. 3.33:16	 MPP 5: fig. 3.19:31-32

*Note.* Drawing is not to scale.

Thickened and ridged rims are common on cooking pots at Tall al-‘Umayri. The Iron II/Persian period has several examples (Lawlor 2000: fig. 3.30:11-14; Low 1997: fig. 7.16:30) but most examples come from Persian period strata (Berge and Willis 2002: figs. 5.13:15; 5.21:5-6; D. R. Clark 1991: fig. 4.9:12-13; 2002: fig. 4.46:3-5; Lawlor 1991: fig. 3.15:10-12, 17-19, 21-22; 1997: figs. 3.12:9; 3.17:24-26; 3.22:25; 2000: fig. 3.33:15-18; Low 1991: fig. 8.22:7-8). The rim profile is characterized by a single slight or rather pronounced ridge below the lip and is found on many Persian period shards (e.g., Lawlor 1991: figs. 3.15:10-12; 17-22; 3.17:24; Low 1991: fig. 8.22:7). Most of the Iron II/Persian period shards had a slight ridge although one (Low 1997: fig. 7.16:30) had a very pronounced ridge. At times, in both time periods, the wall profile by the ridge may be upright, almost forming a neck (Lawlor 1991: fig. 3.15:19; 2000: figs. 3.30:11-12; 3.33:15). A rather common feature on Persian period cooking pots with a ridged rim is a pair of loop handles.

A variant of the single-ridged rim is a multiple-ridged rim. Only one shard (Low 1997: fig. 7.16:32) from the Iron II/Persian period was found, whereas several shards (D. R. Clark 2002: fig. 4.46:8; Lawlor 1991: fig. 3.15:13-16, 26-27; 1997: fig. 3.23:1; 2002: fig. 3.18:9; Low 1991: fig. 8.22:14) dating to the Persian period were uncovered. This variant rim usually has a slightly insloping neck with several ridges on the exterior sidewall. The insloping neck may also be vertical (Lawlor 1997: fig. 3.23; 2002: fig. 3.18:9). Two loop handles (Lawlor 1991: fig. 3.15:26; 1997: fig. 3.23:1) also may be present.

The second type of cooking pot found at Tall al-'Umayri has a bulbous, sometimes pointed, rim profile. The majority of shards with a bulbous rim profile are Persian period (Berge and Willis 2002: fig. 5.13:13-14; Clark 2002: fig. 4.46:6-7; Lawlor 1991: fig. 3.15:20, 23-25; 1997: figs. 3.12:10-11; 3.17:27-32; 3.18:3; 3.22:26-29; 2000: fig. 3.33:19; 2002: fig. 3.19:31-32; Low 1991: fig. 8.22:9-13), whereas only two shards (D. R. Clark 2002: fig. 4.43:2; Low 1997: fig. 7.16:31) date to the earlier Iron II/Persian period.

The most common rim profile of this cooking pot is bulbous. Pointed rim profiles are present (Lawlor 1991: fig. 3.13:23-25; 1997: fig. 3.17:29) with a few flattened, almost pendant-shaped, rims (Lawlor 1997: figs. 3.18:3; 3.22:28). Loop handles are quite common on this type of cooking pot.

A variant of the bulbous rim profile possesses a possible neck. These rims (Lawlor 1997: figs. 3.18:1-2; 3.23:2) have an everted rim that forms a very short neck. This variant is found only in the Persian period ceramic corpus.

Due to its function of food preparation, the ware of the cooking pot is usually thick and constant. This constant thickness allows the heat to remain stable throughout the lower parts of the vessel. Ware colors include red (red, light red, pale red, or weak red), reddish yellow, pink, brown (brown, light reddish brown, reddish brown, or light brown), and gray (gray, reddish gray, dark reddish gray, or pinkish gray). Core colors include pink, gray (gray, dark gray, pinkish gray, reddish gray, dark reddish gray, or light gray), red (red, light red, pale red, or weak red), and brown (light brown, light reddish brown, reddish brown, or gray brown).

Surface treatment includes light to medium slip of colors red (red, yellowish red, light red, weak red, pale red, or dusky red), reddish yellow, gray (gray, dark gray, reddish gray, dark reddish gray, pinkish gray, light brownish gray, or very dark gray), pink, pinkish white, black, and brown (light reddish brown or reddish brown). Decoration includes ridging, finger impression, and incising.



### Mortaria

At Tall al-‘Umayri, mortaria are uncommon but several have been found. These mortaria include examples from the Persian period (Lawlor 1991: fig. 3.15:28; 1997: fig. 3.22:24; Low 1991: fig. 8.22:3-5; see also Herr 1989: fig. 19.16:16-17, 19) and a possible single example from the Iron II/Persian period (Herr 1989: fig. 19.10:8). Three types of mortaria from Tall al-‘Umayri can be differentiated (Table 17).

The first type of mortaria is shallow with smooth exterior sidewalls. Three mortaria of this type were found at Tall al-‘Umayri (Lawlor 1997: fig. 3.22:24; see also Herr 1989: fig. 19.16:16-17). They were made to imitate basalt mortars with chunky, gray ware and a thickened rim. Short tripod legs may sometimes be found on the bottom

of these mortaria (Lawlor 1997: fig. 3.22:24; see also Herr 1989: fig. 19.16:16). The lone Iron II/Persian period shard (Herr 1989: fig. 19.10:8) is a large shallow bowl with thick, gray ware and smooth exterior sidewalls. It was intended to look like mortars made of magmatic stone (gabbro or basalt). This mortar is shallower than those of the Persian period.

TABLE 17  
TYPES OF MORTARIA

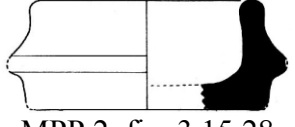
Period	Shallow with Smooth Exterior Sidewalls	Shallow with Wavy Exterior Sidewalls	Flat Base with 90° Sidewalls
Persian	 MPP 3: fig. 3.22:24	 MPP 2: fig. 8.22:5	 MPP 2: fig. 3.15:28

*Note.* Drawing is not to scale.

The second type of mortaria is shallow with wavy exterior sidewalls. No Iron II/Persian period examples were found at Tall al-‘Umayri, but four Persian period examples were uncovered (Low 1991: fig. 8.22:3-5; see also Herr 1989: fig. 19.16:19). The sidewalls of these mortaria flare out at the bottom but vertically curve upward toward the rim. The exterior sidewall of the vertical portion possesses waves. Rims are generally squared but may be slightly rounded.

The third type of mortaria has a single example (Lawlor 1991: fig. 3.15:28). This mortar has a flat base with 90° sidewalls. Almost at the midway point of the sidewall, an exterior ridge circles it. The rim is rounded.

## Jars

The second major category of ceramic form is the jar. A third major form category of jug, however, possesses a similar rim profile and causes confusion when assigning terms like “jar” or “jug” to specific rim shards (Herr 1995: 618; 1997b: 245). A difference between jar and jug rim profiles is that jug rims more typically have a thickened, crescent-shaped rim (Herr 1995: 618). Also, the necks of the jars may or may not have ridges and range from very short to rather tall.

Jars during the Iron II/Persian period and the Persian period can be divided into two types, necked and holemouth. A necked jar possesses an elevated rim connecting above the body of the vessel. The holemouth jar has an inturned rim profile. The jar form category also includes large storage jars, called pithoi, and smaller jars called amphoriskoi. Each of these jars will be discussed.

### **Necked Jars**



The most common type of jar dating to the Iron II/Persian and Persian periods at Tall al-‘Umayri is the necked jar. The necked jar occurs in a wide range of varieties, with many dating to the Iron II period (D. R. Clark 1991: fig. 4.7:1-8; 1997: fig. 4.32:1-3; Low 1991: figs. 8.6:15-16; 8.9:1; 8.13:7-26). The two most popular necked jars have either an insloping neck or a cylindrical neck (Table 18).

Jars with insloping necks are common throughout both Iron II/Persian and Persian periods. Insloping of the neck generally produces a “^shaped” neck profile and a rather narrow mouth opening. The Persian period shards of this type (Lawlor 1991: figs. 3.12:5-6, 8-9; 3.25:3-4; 1997: figs. 3.12:1-2; 3.15:6-10; 3.22:4-6; 2000: fig. 3.32:4-6; Low 1991: fig. 8.19:3-6; 9-10, 12) outnumber shards from the Iron II/Persian period (D. R. Clark

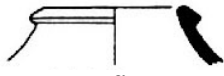
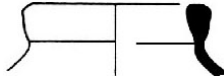
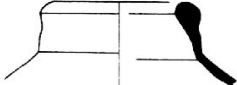
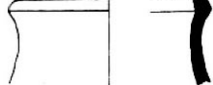

2002: fig. 4.43:9-11; Lawlor 2000: fig. 3.29:4-7; 2002: fig. 3.6:5; Low 1997: fig. 7.15:6-7; see also Herr 1989: figs. 19.5:15-17; 19.6:11). Necked jars may either be grooved or ungrooved (e.g., Lawlor 1997: figs. 3.15:7; 3.22:4, 6). If the neck is grooved, three to five grooves generally are seen (e.g., Lawlor 1997: figs. 3.12:1-2; 3.15:6; Low 1991: fig. 8.19:3-6). Grooved necks occur in both the Iron II/Persian period and the Persian period. One characteristic that seems to be unique to the Persian period is a single groove on the jar neck (Lawlor 1991: fig. 3.12:6, 8-9). This variant grooved jar may possess an almost upright, vertical neck, making it very similar to jars with cylindrical necks (compare Lawlor 1991: fig. 3.12:8 with Lawlor 1991: fig. 3.12:7).

TABLE 18  
NECKED JARS

Period	“^”-shaped” Insloping Neck Profile	Slightly Inward Sloping Neck	Cylindrical Neck
Iron II/Persian	 MPP 5: fig. 3.6:5	 MPP 4: fig. 3.29:8	Not found
Persian	 MPP 4: fig. 3.32:5	 MPP 5: fig. 3.18:19	 MPP 5: fig. 3.6:15

*Note.* Drawing is not to scale.

Rim profiles on these jars usually have external thickening resulting in a triangular profile that either flares downward like a pendant (e.g., D. R. Clark 2002: fig.

4.43:10-11) or upward (e.g., Lawlor 1997: fig. 3.15:9-10). Upward flaring rims seem to be more apparent during the Persian period than the Iron II/Persian period.

Lip profiles on insloping necked jars vary. Most lips are pointed upward due to the triangular profile of the rim. Other lip profiles, such as a flat lip (e.g., Lawlor 2000: fig. 3.32:6; Low 1991: fig. 8.19:12) and a rounded, symmetrically thickened rim (Lawlor 2000: fig. 3.32:5) are also found. Both of these lip profiles seem to appear only during the Persian period.

In addition to insloping necked profiles, jars with cylindrical neck profiles are also very frequent at Tall al-‘Umayri. Cylindrical necked jars are common during the Persian period (Berge and Willis 2002: fig. 5.13:1; Lawlor 1991: figs. 3.12:7, 10-12; 3.25:5; 1997: fig. 3.15:5; 2002: figs. 3.6:15; 3.18:16, 19; Low 1991: fig. 8.19:7-8, 11). It does not seem popular, however, during the preceding Iron II/Persian period as only a few shards were found (D. R. Clark 2002: fig. 4.43:12; Lawlor 2000: fig. 3.29:8; see also Herr 1989: fig. 19.5:9-14). The former two shards of the Iron II/Persian period are tentatively termed “jar” and placed here but may also be termed “jug” due to a symmetrical rim profile (Lawlor 2000: fig. 3.29:8) and its close resemblance to jug forms (compare D. R. Clark 2002: fig. 4.43:12 with D. R. Clark 2002: fig. 4.43:13).

The cylindrical neck of the jar may tend to slightly slope inward, almost appearing as an insloping necked jar (Lawlor 1991: fig. 3.12:7), or be elongated (Lawlor 1991: fig. 3.12:10-11; 2002: fig. 3.6:15). As with insloping necked jars, cylindrical necked jars may appear with grooving (e.g., Berge and Willis 2002: fig. 5.13:1; Lawlor 1997: fig. 3.15:5; Low 1991: fig. 8.19:7-8) or without grooving (e.g., Lawlor 2002: fig. 3.6:15; Low 1991: fig. 8.19:11).

Lip profiles on cylindrical necked jars somewhat vary. The most common lip profile is pointed upward (e.g., Lawlor 1997: fig. 3.15:5). Rounded profiles have also been found (Lawlor 1991: fig. 3.12:10-11; 2002: fig. 3.6:15). This profile is found only on cylindrical necked jars with no grooving and a rather elongated neck.

One unique cylindrical necked jar must be mentioned. A squat jar with a vestigial ridge on the neck and rounded base (Herr 1989: fig. 19.5:23) was found *in situ* in an Iron II/Persian period stratum. It is the only published whole form of the necked jars. It possesses the characteristic thickened triangular rim frequent on necked jars from Tall al-‘Umayri. A variant form with a vestigial ridge at the base of the neck is found in the Iron II/Persian period (Herr 1989: fig. 19.5:22) and on insloping necked jars of the Persian period (Lawlor 1991: fig. 3.12:6, 8-9; see also Herr 1989: fig. 19.12:4). The squat jar has two loop handles, one on either side of the vessel, and a rounded base.

Several necked jar types were found in Iron II/Persian period strata at Tall al-‘Umayri but not in Persian period strata. One type is a small handleless jar with a body that tapers to a pointed base (Herr 1989: fig. 19.5:1-2). This form is dated to the second half of the seventh century B.C. (Herr 1989: 302-303). A second type not found in the Persian period strata but in the Iron II/Persian period strata is a wide-mouthed jar with a short neck and an everted, flaring (out-turned) rim (Lawlor 2002: fig. 3.6:4; Low 1997: fig. 7.15:4; see also Herr 1989: fig. 19.5:20-21). The rim on this form has the characteristic triangular rim profile with a pointed lip (Herr 1989: 303). A third type of necked jar that did not continue into the Persian period has thickened rims with a short neck and flat lip (Herr 1989: fig. 19.5:25). The last type has an elongated thickened rim

(Herr 1989: fig. 19.5:26-27), but possibly may have some Persian period parallels (Lawlor 1991: fig. 3.12:10-11; 2002: fig. 3.6:15).

A form that may have begun in the Persian period (Herr 1989: 307) has a thin body wall with a sloping, ridged neck and everted, pendant rim (Lawlor 1997: fig. 3.15:7; see also Herr 1989: fig. 19.12:3). Some Iron II/Persian period shards have similar wall thickness and rim profile but no examples have a ridged neck. Although this form is very close to looking like a decanter, the neck is too sharply sloping for it to be one.

Ware colors include red (pale red or light red), yellow (pale yellow or reddish yellow), pink, gray (olive gray, light gray, reddish gray, pinkish gray, or light brownish gray), and light reddish brown. Core colors include gray (gray, light gray, or dark gray), pale red, light reddish brown, and reddish yellow.

Surface treatments include light to heavy slip on the rims and necks or unslipped. Colors include red (light red, weak red, or pale red), reddish yellow, pink, brown (brown, light brown, light reddish brown, or very pale brown), white, and gray (gray, light gray, reddish gray, pinkish gray, or light brownish gray). Decoration includes ridging on the neck and rim, tool and finger impressions on the neck, incising, and grooving.

### **Holemouth Jars**

The second major category of jars found at Tall al-‘Umayri is a holemouth jar. This jar type possesses an inturned rim profile. Necked jars significantly outnumber holemouth jars during the Iron II/Persian and Persian periods. No holemouth jars were found during the 1992 and 1994 excavations at Tall al-‘Umayri. A reason for this lack of holemouth jars is that their form is very similar to the form of kraters and so what was termed “holemouth jar” during the first seasons of excavation, now was termed “krater.”

Holemouth jar rims may appear on vessels with vertical sidewalls (Table 19). A few examples with vertical walls were found in Iron II/Persian period strata (Low 1997: fig. 7.15:2-3; see also Herr 1989: fig. 19.5:3-8). Persian period shards were more numerous (Lawlor 1991: fig. 3.12:2-4; 1997: fig. 3.15:3; see also Herr 1989: fig. 19.12:6, 7). The profile of the holemouth rim is usually thickened and horizontal, sometimes with a minor elongated ridge where it inflects inward, creating a slight T-shape appearance (e.g., Lawlor 1991: fig. 3.12:3-4; Low 1997: fig. 7.15:3). Shards from the Iron II/Persian and Persian periods exhibit this rim profile. Lips are usually rounded at the end of the rim although one rim tends to point upward (Lawlor 1991: fig. 3.12:2). This type of holemouth jar is found ungrooved or with one or more grooves along the sidewall below the rim (Lawlor 1991: fig. 3.12:3). A rare form has a rather pronounced deep groove on the horizontal portion of the rim (Low 1997: fig. 7.15:2).

TABLE 19  
HOLEMOUTH JARS

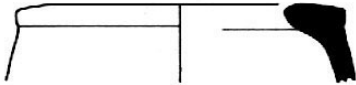
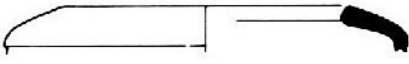
Period	Thickened and Horizontal Rim	Flattened Rim
Iron II/ Persian	 <p>MPP 3: fig. 7.15: 3</p>	Not found
Persian	 <p>MPP 3: fig. 3.15:3</p>	 <p>MPP 3: fig. 3.22:2</p>

*Note.* Drawing is not to scale.

Another type of holemouth jar has a more flattened lip profile. It occurs only during the Persian period (Lawlor 1997: figs. 3.15:4; 3.22:2-3; Low 1991: fig. 8.19:13). The rims may possess exterior grooving along the rim or remain ungrooved. One form (Lawlor 1997: fig. 3.22:3) has a single groove below the rim producing a shouldering effect.

Ware colors include pink, red (red or weak red), reddish yellow, brown (brown or light reddish brown), and gray (gray or very dark gray). Most Persian period forms have pink exterior and interior colors. Core colors are dominantly gray (gray and light gray) but also pale red. No red cores are found in Persian period forms, only (light) gray cores. Surface treatments include a (medium) slip most commonly on the exterior in colors of pink, brown, and reddish yellow. Decorations consist of tool impressions on the rim or neck and ridging or grooving.

### **Miscellaneous Jar Forms**

Several assorted jar forms of the Persian period occur at Tall al-‘Umayri. These miscellaneous forms include pithoi and amphora/amphoriskos.

#### **Pithoi**

In addition to the necked and holemouth jar forms, another form of jar is a pithos (Table 20). The pithos is common in the Iron II through the Persian period at Tall al-‘Umayri with very little change. Examples from the Iron II period are numerous (Low 1991: figs. 8.6:13-14; 8.12:1-3; 8.13:1-6; 1997: fig. 7.15:1), as are ones from the Iron II/Persian period (D. R. Clark 2002: figs. 4.43:6-8; 4.51:9, 13; Lawlor 2000: fig. 3.29:1-3; Low 1997: fig. 7.15:1) and the Persian period (D. R. Clark 1991: fig. 4.9:7; 2000: fig.

4.36:5; Lawlor 1991: figs. 3.12:1; 3.25:1-2; 1997: figs. 3.15:2; 3.22:1; 2000: fig. 3.32:1-3; 2002: fig. 3.18:13-15; Low 1991: fig. 8.19:1-2). A thick, inverted bulbous rim characterizes the most common type of pithos. The pithos is without a neck, although the bulbous rim may produce a so-called “neck” from the way it protrudes from the wall. The lips of the Iron II forms seem to be more flattened than the rounded lips of the Persian period, although one Persian period rim (Lawlor 1991: fig. 3.25:2) shows a slight inner elongation that gives a flattened appearance.

TABLE 20

PITHOI

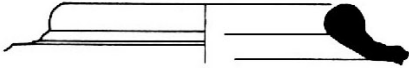
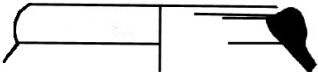
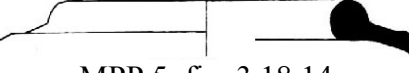
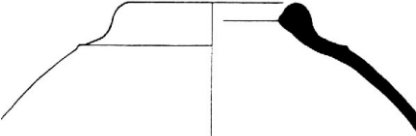
Period	Thick, Inverted, and Bulbous Rim	Inwardly Thickened Rim with Flattened Lip Profile
Iron II/ Persian	 MPP 4: fig. 29:1	 MPP 5: fig. 4.43:8
Persian	 MPP 5: fig. 3.18:14	 MPP 4: fig. 3.32:3

*Note.* Drawing is not to scale.

A variant rim shape is not bulbous but more inwardly thickened and with a flattened lip profile (Lawlor 1991: fig. 4.9:7; 2000: fig. 3.32:3; 2002: fig. 4.43:8; Low 1991: fig. 8.19:2; see also Herr 1989: figs. 19.5:28; 19.12:15). The rim does not rise above the wall (or neck) but seems to be an extension of the wall. The form is not found

in the Iron II strata at Tall al-‘Umayri and may be indicative of the Persian period, with only one shard dating to the Iron II/Persian period (D. R. Clark 2002: fig. 4.43:8).

Besides one shard with a flattened rim profile, the Iron II/Persian period strata also yielded one unique pithos shard that does not have a parallel during the Persian period. This rim (Low 1997: fig. 7.15:5) has an everted flaring rim with ridges along the exterior side of the neck.

Ware colors are usually red (weak red, pale red, or light red), light reddish brown, reddish yellow, and pink. Core colors were always gray (gray or light gray). Manufacture was wheel made, but one showed evidence of coiling (Lawlor 1997: fig. 3.22:1).

Surface treatment included light to medium slip of colors of pink, red (light red or weak red), reddish yellow, brown (very pale brown, light reddish brown, or light brown), and gray (light gray or pinkish gray). Decoration included ridging or incising. The incising may result in a ridge just below the rim on the shoulder of the wall (Herr 1989: fig. 19.12:12). The technique is also seen in the Iron II period (Low 1991: fig. 8.13:3, 6).

#### Amphora/Amphoriskos

The final, but extremely rare, jar form found at Tall al-‘Umayri is an amphora, a jar with two handles located on opposite shoulders (Hendrix, Drey, and Storfjell 1996: 46). Its smaller version is called amphoriskos. The three ‘Umayri examples possibly date to the Iron II/Persian period. The lone amphora (Herr 1989: fig. 19.5:29) was found in an apparent secondary deposit and may precede the actual assemblage. The amphora has tall, ridged neck and incurving rim common to the Ammonite corpus. Two amphoriskoi (Herr 1989: fig. 19.6:17-18) were also unearthed. Both vessels have high, ridged necks with incurving rims and two handles looping from the neck ridge to the shoulder. In



addition, the vessels have stepped bases and parallel painted lines on the rim, neck, and sidewalls.

### Jugs

The third major category of ceramic form found at Tall al-‘Umayri is the jug (Table 21). A jug is a specialized vessel used for pouring a liquid. The jug category, however, is difficult with which to work for two reasons. First, jugs and jars possess very similar rim and neck profiles which cause confusion when assigning terms like “jar” or “jug” to specific rim shards (Herr 1995: 618; 1997b: 245). Both vessel categories may have a similar triangular rim profile (Herr 1995: 618; 1997b: 245). A difference between jar and jug rim profiles is that jug rims more typically have a thickened, crescent-shaped rim (Herr 1995: 618). To add to this confusion, some profiles, for example, necks with a groove and ridge, seem to be classified as either jar or jug, depending on the perspective of the ceramicist. When the category of a vessel is doubted, function determines its designation. Jars are used for storage while jugs are used for pouring. The ceramicist assigns the category based on his or her understanding of the function of the vessel even though the vessel may be similar to its counterpart.

Second, differentiating between a jug and juglet raises a concern. Since the basic forms of jugs and juglets are similar, the difference is one of size: How small is the smallest jug or how big is the biggest juglet? To simplify the difference, juglets are generally thought to be able to be held comfortably in the palm of one hand. Jugs and juglets will be discussed together based on rim profiles. Rim profiles of jugs (and juglets) at Tall al-‘Umayri mainly fall into four types. The first type is a triangular, everted rim, bent almost into a pendant. The second type is a thickened rim in the form of a crescent.

The third type of jug rim profile includes a vertical neck with a simple upright rim. The fourth type also has a vertical neck but with a simple, rounded, and everted rim.

TABLE 21  
EXAMPLES OF JUGS

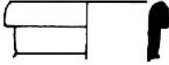
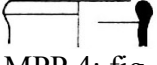
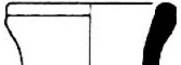
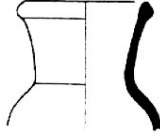
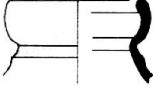
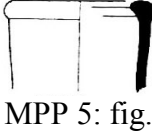
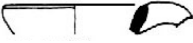
Period	Triangular, Everted Profile	Thickened (crescent) Rim	Simple Upright Rim with Vertical Neck	Simple, Everted, and Rounded Rim with Vertical Neck
Iron II/ Persian	 MPP 4: fig. 3.29:9	 MPP 4: fig. 3.29:10	Not found	 MPP 4: fig. 3.29:12
Persian	 MPP 4: fig. 3.32:7	 MPP 4: fig. 3.32:10	 MPP 5: fig. 3.6:16	 MPP 5: fig. 3.18:17

*Note.* Drawing is not to scale.

### Triangular, Everted (Pendant) Rims

The first type of rim profile of the jug category is a vessel with a triangular, everted rim. The rim may be bent so far over that the resulting appearance is a pendant. Both the Iron II/Persian period (Lawlor 2000: fig. 3.29:9, 11; Low 1997: fig. 7.15:8-11; see also Herr 1989: fig. 19.6:2-3; 8-9) and Persian period (D. R. Clark 2002: fig. 4.43:13-14; Lawlor 1991: fig. 3.25:7; 1997: fig. 3.15:11, 20; 2000: fig. 3.32:7; Low 1991: fig. 8.19:15-16) have many examples. The more-bent-over rim profile resembling a pendant

seems to be more common during the Persian period (D. R. Clark 2002: fig. 4.43:13; Low 1991: fig. 8.19:16).

Lip profiles on these triangular rims vary. The flattened lip was quite common during the Iron II/Persian period (Low 1997: fig. 7.15:8-9, 11) but does appear in the Persian period (Low 1991: fig. 8.19:15). Two other, although less common, lip profiles include a bulbous lip (Low 1997: fig. 7.15:10) and a rounded lip (D. R. Clark 2002: fig. 4.43:14). On most of the rim shards, a groove and ridge combination appears below the rim. A similar decoration appears on jars as well, contributing to the confusion between these two form categories. Jug vessels may also possess a loop handle (D. R. Clark 2002: fig. 4.43:13).

### **Thickened, Crescent-shaped Rims**

The second rim profile on jugs found at Tall al-‘Umayri is a thickened rim that curves inward to form a crescent shape. This rim profile is typical on jugs (Herr 1995: 618). Similar to the triangular rim profile, the crescent-shaped rim was used during the Iron II/Persian period (Berge and Willis 2002: fig. 5.20:7-8; D. R. Clark 1997: fig. 4.32:9; Lawlor 1991: fig. 3.12:15; 2000: fig. 3.29:10; Low 1997: fig. 7.15:12; see also Herr 1989: fig. 19.6:4-5) and into the Persian period (Berge and Willis 2002: fig. 5.14:1; D. R. Clark 2000: fig. 4.36:7; Lawlor 1997: figs. 3.15:8, 22; 3.22:10; 2000: fig. 3.32:8-11; see also Herr 1989: fig. 19.12:17-18). Crescent-shaped rim profiles generally have a narrow mouth opening, but several wide mouths were found dating to both periods (e.g., Berge and Willis 2002: fig. 5.20:7; Lawlor 2000: fig. 3.32:10-11). The wider mouths seem to be more frequent during the Persian period. Two inverted rims (Lawlor 1991: fig.

3.12:15; 2000: fig. 3.29:10) with slight inward bents, dating to the Iron II/Persian period, may be variant forms of the crescent-shaped rim or precursors to it.

Grooves decorate several shards. Grooves alone appear on an Iron II/Persian period shard (Low 1997: fig. 7.15:12) as well as a Persian period example (Lawlor 1997: fig. 3.22:10). Another Persian period rim (D. R. Clark 2000: fig. 4.36:7) has a groove on the rim that forms almost a ridge. This vessel was found intact and has a loop handle extending from the rim to the upper shoulder on the body as well as a concave flat base. A loop handle was also found on an Iron II/Persian period jug (Berge and Willis 2002: fig. 5.20:8) as well as a Persian period juglet (Berge and Willis 2002: fig. 5.14:1).

An infrequent variant form of the crescent-shaped rim from Tall al-‘Umayri is an offset rim in the shape of a cup. This cup-like rim appears on an Iron II jug shard (Low 1997: fig. 7.11:3) and Iron II/Persian period shards (Lawlor 1991: fig. 3.12:13; Lawlor 2000: fig. 3.29:14; see also Herr 1989: fig. 19.6:12-13, 16, 36). The juglet (Lawlor 2000: fig. 3.29:14) seems to possess an almost carinated neck. A possible Persian period shard (Herr 1989: fig. 19.12:23) was found, although no other Persian period examples have been confirmed at Tall al-‘Umayri.

### **Vertical Necks with Simple Upright Rims**

The third type of rim profile seen on jugs is a simple upright rim on top of a vertical neck. This rim type of jug is far less frequent than the previous two types. Several shards dating to the Persian period were found (Lawlor 1991: fig. 3.12:14, 16, 19, 21; 2002: fig. 3.6:16; Low 1991: fig. 8.19:14; see also Herr 1989: fig. 19.12:22). The Iron II/Persian period seems to be void of any examples of the simple upright rim although several possible ones may exist (Herr 1989: fig. 19.6:21-23).

Upright rims may be thickened (Lawlor 1991: fig. 3.12:14, 16), flattened (Low 1991: fig. 8.19:14), or rounded (Lawlor 2002: fig. 3.6:16). The necks are generally vertical to almost cylindrical with one neck showing a slight outward lean (Low 1991: fig. 8.19:14). In addition, necks from the Persian period are ungrooved although one possible shard from the Iron II/Persian period (Herr 1989: fig. 19.6:21).

### **Vertical Necks with Simple, Rounded, and Everted Rims**

The fourth type of rim profile on jugs from Tall al-‘Umayri is similar to the third type of rim profile. Although the fourth type has a vertical neck like the third type, it has a simple, rounded, and everted rim profile instead of an upright profile. Everted rim profiles seem to be common during the Persian period as most examples were found in strata dating to this period (Lawlor 1991: fig. 3.12:17-18; 1997: figs. 3.15:12-14, 17, 21; 3.22:7-9, 11, 13; 2000: fig. 3.32:7; 2002: fig. 3.18:17-18; Low 1991: fig. 8.19:17; see also Herr 1989: fig. 19.12:19-20). Some examples (D. R. Clark 2002: fig. 4.43:15; Lawlor 2000: fig. 3.29:12; Low 1997: fig. 7.15:13; see also Herr 1989: fig. 19.6:24) possibly may date to the Iron II/Persian period. Two of these three examples (D. R. Clark 2002: fig. 4.43:15 and Low 1997: fig. 7.15:13) are juglets.

Everted rims are characterized by a simple, rounded rim profile. In addition to a rounded lip, everted rims may also have a pointed lip profile (e.g., Lawlor 1997: figs. 3.15:13; 3.22:8; 2000: fig. 3.32:7). The pointed lip may extend noticeably upward (Lawlor 2002: fig. 3.18:17-18). The upward pointed lip profile appears on the Iron II/Persian period shard as well. A flattened lip appears on one Persian period shard (Lawlor 1991: fig. 3.12:17). Loop handles are very common on this jug type (Lawlor 1997: figs. 3.15:13, 17; 2002: fig. 3.18:17-18).

A possible variant of the fourth rim type has a short neck and a wider mouth. Three examples from the Persian period exhibit these characteristics (Lawlor 1997: figs. 3.12:3; 3.15:15; 3.22:8). Two of the rims have rounded lips while the latter one shows a pointed lip. One rim (Lawlor 1997: fig. 3.15:15) has a groove on the exterior of the rim.

Two final Persian period jug examples (Lawlor 1991: fig. 3.25:6; 1997: fig. 3.22:12) come from Tall al-‘Umayri. The former jug has a unique inverted neck as opposed to an upright or everted neck. The lip is pointed upward. Although this vessel does possess a loop handle as several other jug forms do, the loop handle arches high above the mouth of the vessel. The latter juglet has an inverted sidewall profile with the rim sitting on a very short everted neck. A groove appears on the upper lip of the rim. The distinguishing characteristic of this Persian period shard is the chevron decoration on the exterior of the rim (for a discussion on the use of chevrons during the Persian period, see p. 130).

For both periods, exterior ware colors included brown (brown, light reddish brown, pale brown, very pale brown, or light brown), red (red, pale red, or yellowish red), and pink. Only Persian period shards exhibited gray (gray, light gray, or pinkish gray) ware. Interior colors included brown (very pale brown or light reddish brown), reddish yellow, gray (light gray or pinkish gray), red (light red or yellowish red), and pink.



### **Miscellaneous Jug Forms**

Several assorted jug forms of the Persian period occur either at Tall al-‘Umayri. These miscellaneous forms include alabastrons and flasks (Table 22).

## Alabastrons

The first form is an alabastron (or bottle), a specialized jug form that is short with a narrow neck and a long body. This vessel mimics an earlier jug form made of alabaster (thus the name “alabastron”) and is typically “used for storage of perfumes and precious oils and often possessed flattened, disk-shaped lips useful for applying perfume without wasting it” (Hendrix, Drey, and Storfjell 1996: 54).

TABLE 22  
MISCELLANEOUS JUG FORMS

Period	Alabastron	Flask
Iron II/Persian	Not found	Not found
Persian	 MPP 3: fig. 3.15:1	 MPP 3: fig. 3.18:7

*Note.* Drawing is not to scale.

Alabastrons are not common to the ceramic corpus of the Persian period of Tall al-‘Umayri although one has been identified (Herr and Platt 2002: 391; fig. 16.34:1983; Lawlor 1997: fig. 3.15:1). This complete vessel was dated to the Iron II/Persian period but accompanying ceramic evidence may hint at a Persian date. It possesses an elongated, cylindrical body with an overturned, disk-shaped rim that is flattened around the exterior. Although complete, it is only 16 centimeters in length.

## Flasks

The third jug form is a flask, a short, specialized vessel used to store and dispense liquid. Only a few flask shards have been unearthed at Tall al-‘Umayri (Lawlor 1997: fig. 3.18:7; see also Herr 1989: fig. 19.17:13). The latter shard is of the upper part of the flask, showing the remnants of two loop handles extending from the ridge on the neck. The rim is triangular and everted. The former flask shard is of the body. It features concentric circles of dark brown paint.



## CHAPTER 4

### CONCLUSIONS

#### **Conclusions**

The purpose of this dissertation was to establish a pottery typology of the Persian period at Tall al-‘Umayri as well as to discover any ceramic changes between the Iron II/Persian period and the Persian period. Using Tall al-‘Umayri as a type site, Persian period pottery drawings were systematically collected, examined, organized, and presented. In addition, to emphasize the typology of the Persian period pottery, comparison with Iron II/Persian was made. The resulting typology of Persian pottery at Tall al-‘Umayri will assist archaeologists and ceramicists in dating and determining Persian period findings within the context of other completed or ongoing excavations. As a result of the comparison between Iron II/Persian and Persian period pottery, similarities and differences between these two pottery types at Tall al-‘Umayri were discerned. As the results here show, similarities and differences may be found both in form and in surface treatment.

#### **Suggestions for Further Research**

The intent of this study is to be a starting point, not a finishing point. As research continues in this area, better defined conclusions will be drawn. In order to facilitate

continuing progress in the understanding of Persian period pottery, a few areas of further research may be suggested.

The first suggestion is to further analyze and compare the Persian period pottery at Tall al-‘Umayri. Although this study compared Iron II/Persian period pottery and Persian period pottery, another comparison might be done between Persian period and Iron Age pottery. This research would further define Persian period pottery by analyzing and comparing individual pottery forms for a much broader time frame to discern if any forms or surface treatments began in Iron Age II or in the Iron II/Persian period and continued into the Persian period.

A second suggestion is to compare the findings from Tall al-‘Umayri with pottery from other sites. This suggestion, however, depends on the publication of well-stratified sites. Having said this, field reports of several sites are in the publication process. Tall Dayr ‘Alla is close to publication. Tall Jalul and Tall Safut are also currently in the publication process. These sites possess well-defined stratigraphy with Persian period pottery. By comparing the pottery typology put forth in this dissertation with the pottery of these and other sites, a clearer understanding of the Persian period pottery will emerge.

A third suggestion is a cross-regional analysis between the regions of Moab and Edom with Ammon. As Tall al-‘Umayri is located in Ammon, the conclusions drawn in this study might be only regional. By comparing conclusions of my study with that of other Moabite and Edomite sites, a further and more complete understanding of the Persian period pottery throughout all of Transjordan might be accomplished.

In addition to these ceramic comparisons, there exists the research potential for analyzing the various ceramic forms in a sociological and cultural context. This type of

study would examine how the particular characteristics of a society or culture impact the ceramic assemblage of that culture. This study would be instructive in connecting sociological and cultural aspects and their influence on the material culture of the society.

## APPENDIX A

### SITES AND SURVEYS

Below is a growing list of sites and surveys that have produced evidence of Persian period (some including Iron II/Persian period) occupation. The list is not intended to be exhaustive but an initial list of sites that will develop as more Persian period sites are published. As can be seen from the list of sites, the whole area of Transjordan is covered. In addition to the name of the site or survey, a brief description of some of the Persian period remains is provided. Note that the list is weighted toward the territory of the Ammonites due to the extensive Hisban survey of Ibach (1987) and the Baq‘ah Valley survey by McGovern (1989). The intention of this list is to provide an initial listing of sites with evidence of Persian period occupation. The list is not exhaustive and as sites may be added or subtracted when more sites are published, when Persian period artifacts are discovered through recent excavations, or when existing artifacts are studied and re-dated.

#### **Sites**

*Adoni-Nur tomb (Amman)*: Essentially a seventh century BC site, a few Attic imports and sand-core glass dating to c. 500 BC may hint at Persian period occupation (Harding and Tufnell 1953; Sauer 1986: 18).

*‘Ai* (Kerak Survey Site 262): Located two kilometers east-southeast of Kathrabba, two Iron IIC/Persian period shards were found (Miller 1991: 109).

*‘Ainun* (Kerak Survey Site 264): Located four kilometers south-southwest of Kerak and three kilometers north-northwest of Mihna, three Iron IIC/Persian period shards were found (Miller 1991: 110).

*‘Ayun Musa* (Hisban Survey Site 108): A “small site” located ten kilometers west of Tall Hisban, where a few Persian period shards were found (Ibach 1987: 16).

*Al-Drayjat*: Located on a high hill almost three kilometers southwest of Tall al-‘Umayri and west of Khirbat Bishirat, pottery found on bedrock dated no later than the Late Persian and Hellenistic periods. “Pockets” of Iron II pottery suggested that Late Persian and Hellenistic period people cleared the site to bedrock and pushed earlier Iron II debris into these pockets. The site possibly functioned as an Iron II fort (Younker, Herr, Geraty, and LaBianca 1990: 11-14).

*Al-Qasir* (Hisban Survey Site 8): A “small site” on a low hill north of Tall Hisban, a modern village destroyed most of the antiquities although some Iron II/Persian period “bods” remained (Ibach 1987: 11).

*Amman Citadel*: An “Iron III/Persian” period or possibly early Hellenistic pottery lid in deep sounding was discovered (Greene and ‘Amr 1992: 126, fig. 7:6).

*Ateyiq*: Small site on the ridge by the Naur/Madaba road, it was recorded by the Hisban Survey as Site 3. A “few” Iron II/Persian period shards as well as a wine press and some cisterns hint at an agricultural use (Ibach 1987: 10).

*Beddih North* (Hisban Survey Site 72): This “small site” on the “low hill at the fork in the Naur/Madaba, Naur/Umm al-Amad roads” yielded “minimal evidence of architecture and some caves [pls. 100-101].” Some Iron II/Persian period pottery and “possible” Iron I shards were found (Ibach 1987: 20).

*Busayrah*: A cooking pot possibly hinted at a public building in Area C continuing into the Persian period (Bennett 1977: 8, fig. 5:1201).

*Ed-Dimnah* (Kerak Survey Site 64): Located four kilometers northwest of er-Rabbah, one possible Persian period shard was found (Miller 1991: 53).

*El-Hawajib* (Hisban Survey Site 4): A “very small site” by the Naur/Madaba road, a “few” Iron II/Persian period shards and a cistern were found (Ibach 1987: 10).

*El-Mudwara* (Hisban Survey Site 5): A cistern, a “fragment of a wall, a ‘possible tomb,’” and “some rock cuttings on the lower east slope” yielded Iron II/Persian period shards (Ibach 1987: 10).

*El-Qutnah South*: A small site located nine kilometers northwest of the Amman Citadel and half of a kilometer south of Rujm al-Qutnah. The Archaeological Survey of Greater Amman found a “settlement” and cisterns with Iron II/Persian period, Roman, Byzantine, and Arabic pottery (Abu Dayyah, *et al.* 1991: 391, table 2).

*El-Umyan* (Kerak Survey Site 193): Located one kilometer north of Jauza on the north bank of Wadi ‘Isal, three Iron IIC/Persian period shards were found (Miller 1991: 85).

*El-Yarut* (Kerak Survey Site 63): Located three and a half kilometers north-northwest of er-Rabbah and two kilometers west of the Kerak/Dhiban road, one Iron II/Persian period and one possible Persian period shard were found (Miller 1991: 53).

*Er-Rabbah* (Kerak Survey Site 108): Two Iron II/Persian period shards were found (Miller 1991: 65-66).

*Esh-Sharif* (Kerak Survey Site 238): One Iron II/Persian period shard and walls dating to the same period were found (Miller 1991: 101-102).

*Eth-Thaniyyah* (Kerak Survey Site 211): Located two kilometers southeast of Kerak, ten Iron II/Persian period shards were found in foundation lines (Miller 1991: 93-94).

*Gourmeyet Hisban* (Hisban Survey Site 10): A small site on a large hill about one half kilometer northwest of Hisban and overlooking the Wadi Hisban, caves, winepresses, dolmen, and Iron II/Persian period “bods” were found (Ibach 1987: 11).

*Haud Abu Billana*: Located southwest of ‘Ain Ras el-Ma’, it is a “town of at least four hectares which was occupied during the Late Bronze Age. Its citadel was fortified at least toward the end of the Iron Age, possibly during the period of Assyrian or Persian (period) domination” (Gordon and Knauf 1987: 292).

*Hisban*: Ostraca and pottery apparently covering the whole Persian period and a cistern probably originally made in “Iron II/Persian period” were found (Sauer 1994: 246-248; Cross and Geraty 1994: 172-174; Merling 1994: 215-216).

*Hisban Survey Site 6:* A “small site with few antiquities” on the “low rise just south of Khirbat el-‘Al,” “several tombs” with some Iron II/Persian period shards were found (Ibach 1987: 11).

*Hisban Survey Site 9:* Located on “flat land west of the Naur/Madaba road,” two tombs with “cylindrical shafts” and a cistern as well as a “few” Iron II/Persian period bods were found (Ibach 1987: 22).

*Hisban Survey Site 91:* A shard scatter near Naur included Iron II/Persian period and possible Iron I material (Ibach 1987: 22).

*Hisban Survey Site 92:* A shard scatter included Iron II/Persian period shards (Ibach 1987: 22).

*Hisban Survey Site 99:* A “very small site” of shard scatter on a hill east of Naur included Iron II/Persian period shards (Ibach 1987: 23).

*Hisban Survey Site 128:* A “very small site” located two kilometers southeast of Naur yielded a shard scatter and a large plastered cistern with Iron II/ Persian period shards (Ibach 1987: 27).

*Hisban Survey Site 129:* Located two kilometers southeast of Tall Hisban, a shard scatter about 20 × 50 m yielded Iron II/Persian period shards (Ibach 1987: 28).

*Hisban Survey Site 131:* A “medium-sized site” on a hilltop about three kilometers from Na‘aware produced architectural remains with a possible perimeter wall, cisterns and caves as well as Iron and Iron II/Persian period shards (Ibach 1987: 28).



*Hisban Survey Site 136:* Located two kilometers south of Tall al-‘Umayri, this site had a “possible stone tower” with walls and Iron II/Persian period shards (Ibach 1987: 29).

*Hisban Survey Site 138:* A “medium-sized” site one kilometer southwest of Tall al-‘Umayri on the east slope of a large hill, late period architecture with two tombs and two cisterns yielded Iron II/Persian period pottery (Ibach 1987: 29).

*Hisban Survey Site 139:* A “small site” about two kilometers south of Tall al-‘Umayri, “several ruined buildings” with plastered and painted interior walls, cisterns, caves, a plastered tank with internal steps, a bedrock winepress, and Iron II/Persian period pottery were found (Ibach 1987: 29).

*Hisban Survey Site 141:* Located two and a half kilometers west of Tall al-‘Umayri on a hilltop of bedrock, visible walls with a cistern and Iron II/Persian period pottery were found (Ibach 1987: 29).

*Hisban Survey Site 144:* Located two kilometers west of el-Yadudah on a small hill, “several architectural fragments” two plastered cisterns, a cave with “architectural remains inside,” and one tomb as well as the earliest pottery dating to the Iron II/Persian period were found (Ibach 1987: 30).

*Hisban Survey Site 145:* Located two kilometers west-northwest of el-Yadudah, a “possible two-course perimeter wall” with “many caves and cisterns” and “fragments of small grinding mills” as well as Iron II/Persian period pottery were found (Ibach 1987: 30).

*Hmeimat SW* (Kerak Survey Site 90): Located two kilometers east-southeast of el-Qasr and one half of a kilometer north of the Qasr/Hmud road, this site yielded one Iron IIC/Persian period shard with some wall lines and a collapse of one building (Miller 1991: 61).

*Ibn Ayyub*: Overlooking Wadi el-Kerak and located two kilometers west of Kerak, this site produced six Iron II/Persian period shards (Miller 1991: 86, 88).

*Iktanu*: A fort was found (Prag 1989: 40-44, figs. 8-11).

*Imra'* (Kerak Plateau Site 15): Located at the head of Wadi Imra', one Iron IIC/Persian period shard was collected (Miller 1991: 33).

*Iraq el-Amir*: Located 17 kilometers west of Amman, it was visited by C. Crosby in 1904 who did a detailed study of it. Later this site became the home of the Tobiads who were closely related to Ammonites during Persian period (Butler 1919: 34-62).

*Jebel el-Fahud*: The "small site" two kilometers north of el-Yadudah on a low hill yielded a "heavy wall, two rows wide, that encloses an area about 50 × 56 meters at the high point of the hill" with a surrounding wall that was "terrace which is defined by a possible outer perimeter wall" as well as Iron I and Iron II/Persian period shards (Ibach 1987: 30).

*Kerak* (Kerak Survey Site 204): Two Iron II/Persian period shards were found (Miller 1991: 89).

*Khilda*: Two rock-cut tombs dating between the seventh and fifth centuries BC and possibly associated with the Ammonite tower were found (Yassine 1988).

*Khirbat al-Hajjar*: A Phoenician coin found inside a tower dated to around 400 BC but was explained as a post-occupational deposit by the excavator (Thompson 1972: pl. 7; 1977: 31).

*Khirbat al-Balu'*: Located north and south of Wadi Qurri, extensive Iron II ruins with a possible Persian period shard were found (Miller 1991: 41-43).

*Khirbet Belath* (Hisban Survey Site 127): Located two kilometers southeast of Na'aware on a hill, "[s]ome fragmentary architecture," cisterns, caves and tombs on the south side were discovered as well as a large "two-tiered pool," grinding mill, and a "few Iron II/Persian" period shards (Ibach 1987: 27).

*Khirbet Dubab* (Kerak Survey Site 399): Located north of the Khanzirah/Majra road, six Iron IIC/Persian period shards, walls, and cisterns were found (Miller 1991: 148).

*Khirbet el-'Edmah*: Located one and a quarter kilometers southeast of Mursi and north of the Baq'ah Valley, this site is one of several strategic "hilltop forts" occupied between the Late Bronze Age and the Iron or Persian periods (Gordon and Knauf 1987: 292).

*Khirbet el-'Edul* (Kerak Survey Site 307): Located on the northwest bank of Wadi Um el-'Edul and two and a half kilometers east-southeast of Mauta, three Iron IIC/Persian period shards and wall lines were found (Miller 1991: 120).

*Khirbet en-Neqqaz* (Kerak Survey Site 207): Located three kilometers south of Kerak and east of the Kerak/Tafilah road, ten Iron II/Persian period shards and wall lines were found (Miller 1991: 90-91).

*Khirbet Kheshrûm South*: A “very small site” with building foundations yielded Iron II/Persian period pottery (Ibach 1987: 28).

*Khirbet Um el-Dananir*: An “Iron IIC/Persian” period courtyard with an oven and an inscribed storage jar were found (McGovern 1989: 40-42).

*Khirbet Umm el-Qanafid*: Occupied by a village, this “large site” yielded Iron II/Persian period pottery (Ibach 1987: 18).

*Kinnar* (Kerak Survey Site 233): Located two kilometers east-northeast of Kerak at the head of Wadi el-Kinnar, one Iron IIC/Persian period shard was found (Miller 1991: 100).

*Meqabelein tomb*: Sand-core glass dating to around 500 BC and pottery similar to Tall al-Mazar was found (Harding 1950: pls. 13:3, 15:11; Sauer 1986: 18).

*Mgheir* (Kerak Survey Site 197): Located three kilometers west of Kerak, one Iron II/Persian period shard and wall lines were found (Miller 1991: 86).

*Qasr Khelda*: Located seven kilometers northwest of the Amman Citadel and one kilometer east of Khelda, the building plan of this site was of a common fortress during the Iron II period (Stern 1982: 55) and yielded Iron II/Persian period pottery (Abu Dayyah *et al.* 1991: 367).

*Qweilbeh/Abila*: Persian period shards in Area A were found (Mare 1989: 474).

*Rujm al-Hanu East*: Much Iron II/Persian period pottery was found (McGovern 1983: 125) with a sealed Iron IIC/Persian period floor in the *qasr* type of building (McGovern 1983: 136).

*Rujm al-Hanu West*: An “Iron IIC/Persian (period) tower” was found (V. A. Clark 1983).

*Rujm Selim*: Located by Wadi el-Buneyyat and northeast of el-Buneyyat South and ten kilometers south-southwest of the Amman Citadel, this possible agricultural farmstead had an Iron II/Persian period building with a trilobate (Scythian) arrowhead and a Persian period water jug (Geraty, Herr, LaBianca 1988: 226).

*Tawilan*: A cuneiform tablet dating to accession year one of the Achaemenid king named Darius was found in the accumulation deposit over the main occupation (Bienkowski 1990; Bennett and Bienkowski 1995).

*Tall Dayr- 'Alla*: Phases V-II dated to the Persian period with buildings (phase V), wall foundations and small pits (phase III); a fifth-century BC Attic lamp (phase V), fourth-century BC Greek “fish-plate” (phase III), and inscribed ostraca dating between 500-400 BC (van der Kooij 1987b; van der Kooij and Ibrahim 1989: 89-90; Groot 2007; Groot and Dik 2006; 2008).

*Tall al-Fuhhar*: “Iron IIC/Persian” period silos or bins and some architecture were found (Ottosson 1993: 100; Strange 1997).

*Tall Jalul*: A large late Iron II/Persian period building in Field C with pottery of imported Attic ware was found. Field A had several pits, some architecture, and pavement dating to the fifth to fourth centuries BC. Field D had several wall lines of domestic structure(s) (Yunker, Geraty, LaBianca, Herr, and Clark 1996: 72-73).

*Tall al-Mazar*: A cemetery, grain silos, houses, ostraca, and seals date to the Persian period (Yassine 1984; Yassine 1988 b and c; Yassine and Teixidor 1988).

*Tall al-Umayri*: Three stamped jar impressions possibly of the Persian province of Ammon dated to late sixth century BC were found. Several Attic shards of the fifth century BC were discovered in an administrative building with evidence of Iron II continuity (Herr, Geraty, LaBianca, and Younker 1991a: 13, 241-242; 1994: 155; Herr 1992; 1993; 1995; Younker, Geraty, LaBianca, Herr, and Clark 1996: 77-79).

*Tall as-Sa'idiyah*: Stratum III of the square building was dated by an Aramaic inscription with letters characteristic of the late sixth to fourth centuries BC and two ostraca. Recent excavations suggested even earlier phases of building and some Persian period graves (Pritchard 1985: 60-68, 86-87; Tubb and Dorrell 1994: 52-59; Tubb, Dorrell, and Cobbing 1996: 22, 25, fig. 12).

*Tall Nimrin*: one locus with two phases of occupation and partially preserved structures of Persian period with 8 ostraca from 6th-4th centuries BC (Flanagan, McCreery, and Yassine 1992: 98-100; 1994; Dempsey 1993).

*Tell el-Kheleifeh*: Ostraca dating to the fifth and fourth centuries BC were found (Divito 1993: 58-63).

*Tell el-Mugayyir*: Persian period shards associated with a “fort”, a “way station”, or a “caravanserai” dating from the Iron Age to the Hellenistic period were found (Ibrahim and Mittman 1986: 171).

*Um Hamat* (Kerak Survey Site 419): Located seven kilometers east-southeast of Tall al-Mazar and four kilometers southeast of Sul, eight Iron IIC/Persian period shards were found (Miller 1991: 153-154).

*Umm el-Basatin* (Hisban Survey Site 103): A “large” site on the Naur/Umm el-Amad road yielded Iron II/Persian period pottery (Ibach 1987: 24).

*Umm el-Basatin North*: Located northeast of Umm el-Hanafish, a building with crude walls and Iron II/Persian period pottery was found (Ibach 1987: 29).

*Umm Udhaina*: A rock-cut tomb with characteristic Persian metalwork and a fifth-century BC Attic lekythoi were found (Hadidi 1987).

*Unknown* (Kerak Survey Site 263): Located on Jebel el-Batra’, one Iron IIC/Persian period shard and walls were found (Miller 1991: 136).

### **Surveys**

*Baq’ah Valley Survey*: Three “Iron IIC/Persian” (*ca.* 650-400 BC) period sites were found (McGovern 1989: 40-42).

*East Jordan Valley Survey*: Thirteen sites with only small quantities of Persian period shards were discovered. Some continuity between Iron II, Persian, and Hellenistic periods was evident with shards from all three periods found at six sites (Ibrahim, Sauer, and Yassine 1976; Yassine, Ibrahim, and Sauer 1988: 175-177, 198-199).

*Hisban Survey*: “Iron II/Persian” (*ca.* 900-500 BC) period pottery was found at 63 sites which is 43% of sites explored. It was noted that “Late Persian” (*ca.* 500-250 BC) period pottery was almost completely absent with only Tall Jalul yielding three shards (Ibach 1987: 158-168).

*Kerak Plateau Survey*: “Iron IIC/Persian” (*ca.* 540-332 BC) period pottery was discovered at 20 sites (Miller 1991) but diagnostic Persian period pottery was missing (Brown 1991).

*Tall al-Umayri Hinterland Survey*: One “Early Persian” period shard was found at Site 69 (Herr, Geraty, LaBianca, and Younker 1991a: 278).

*Wadi Yabis Survey*: Diagnostic “Persian/Hellenistic” pottery was found at four sites with three sites showing continuity from the Iron II period (Mabry and Palumbo 1989: 94-96).



## APPENDIX B

### PARALLEL POTTERY TYPOLOGY

After the typological analysis of each pottery category and its forms from Tall al-‘Umayri pottery, a brief typological study of other Transjordanian sites with published pottery from the Persian period will be conducted. The purpose of this study is to be a starting point for further research and analysis. It is by no means exhaustive and relies heavily on published parallels by Lugenbeal and Sauer and the Madaba Plains Project volumes. It is the hope that this study will be expanded and added to as Persian period pottery is found and examined. The study will begin with the well-published Ammonite site of Tall Hisban. The typology will then be divided geographically between other Ammonite sites as well as sites from Moab and Edom. Whenever possible, parallels of Persian period forms from non-Transjordanian sites will also be included in order to provide a further basis of comparison. The pottery typology will also be limited to those Transjordanian and non-Transjordanian sites with published illustrations of pottery.

#### **Bowls**

##### Off-Set (bi-angular, everted) Rims

#### **Transjordanian Parallels**

According to Lugenbeal and Sauer, the bi-angular, everted off-set rim corresponds to Heshbon Type Bo:1 (1972: 33-34; nos. 1-93). This rim type comprised a sixth of the total number of rims found at Tall Hisban. As with the Tall al-‘Umayri

corpus, the rims illustrated many variant profiles, including pronounced (nos. 43, 56, 70), external groove (nos. 10-16), several grooves (nos. 36-37, 78), rounded (nos. 2, 46), and flattened (nos. 9, 12, 83).

The ware of the shards was generally thin possessing a very hard external surface. Thicker and softer shards were also found (nos. 1-11). Wall profiles were shallow with some slight carination (nos. 13, 17, 34-35, 70). Although no whole forms were published, bases as deduced from parallels included step-cut bases and disk bases.

The surface treatment of the Tall Hisban shards varied greatly like the ones from Tall al-‘Umayri. Most shards had both interior and exterior wheel burnish applied with a wide instrument resulting in widely spaced bands. Some shards, however, were only burnished on either the interior or exterior. Four main color categories include unburnished shards of tan or buff and burnished shards with slips of red (ranging from pink to darker red, but with the dominant color being light red-orange), brown, or black orange. Brown was as common as the red and included metallic grays and browns while only a few black orange shards were found.

Definite parallels of the off-set rims found at Tall al-‘Umayri and Tall Hisban are commonly found at other Ammonite sites. Good examples come from the tomb at Adoni Nur (Harding and Tufnell 1953: fig. 21:61-63, 65). Number 61 is made of very hard, fine red ware with a gray core, a slightly carinated wall profile, and with red slip on the interior and exterior. Numbers 62 and 63 are also of fine, hard ware but of a buff color, with a red washed interior and ring burnishing inside and out. Number 65 is of a pink ware with gray core with a pink slip all over and ring burnishing. Step-cut bases are on three of the bowls (nos. 61-63) while the fourth has a disk base (no. 65).

The tomb at Meqabelein also provides parallels (Harding 1950: pl. XVII:13-15, 18). The ware colors include brown, black, and buff and each has wheel burnishing.

Further examples come from the Amman Citadel (Dornemann 1983: figs. 53:447; 55:550-556, 558-564; 56:565-568, 570, 573-576, 579-583; 74:557, 569-572, 577, 578). These off-set rims make up Dornemann's Rim Type XLVI and are termed "step-rim" (Dornemann 1983: 109-110). Most of the rims have red burnish but several (nos. 555, 557-560, 563, 577, 580) have black burnish while one (578) has cream burnish.

Similar shards were discovered at Rujm al-Hanu (V. A. Clark 1983: figs. 1:1; 3:1-3). One of the shards (1:1) is of black ware while another had very dark gray ware with wheel burnishing (3:1). Figure 3:2 shows an exterior groove below the rim (similar to Lugenbeal and Sauer 1972: nos. 26, 36).

Glueck noted one shard of this type from Tall Dayr-ʿAlla (1951: 457; pls. 42:4; 132:7). Dated to the Iron I period, Lugenbeal and Sauer (1972: 34) have redated this shard to the Late Iron II period. This shard exhibits a light reddish-brown burnished slip on the interior and exterior walls.

Finally, a vessel with a similar rim was found in Grave 59 of the cemetery at Tall al-Mazar (Yassine 1984: 66; fig. 3:1). The lip of the rim was rounded and the base was a slightly concave disk base. The surface had a blackish reddish slip and was burnished. It was very similar to one found at Adoni-Nur (Harding and Tufnell 1953: fig. 21:63).

Off-set rims are not commonly found outside of the Amman district, for example at Dhiban on the plateau outside of the Ammonite sphere or at Tall as-Saʿidiyah in the Jordan Valley next to the Ammonite plateau (Herr 1987: 304). Two possible reasons exist for this limitation: "first, such bowls are confined to the Amman district and, second, the

Amman district habitation layers and tomb deposits from which they came are later than the material published so far from other sites” (Dornemann 1983: 110). Although this statement was made a little over 27 years ago, it still holds true today. No shards of this type were noted at Moabite sites (Brown 1991) or Edomite sites (Hart 1995b). However, several possible examples may be found at Tell el-Kheleifeh (Pratico 1993: 46, pl. 36:1-3, 5-7). These “inset” or “stepped” rims are grouped with rims having an outcurving inflection.

### **Non-Transjordanian Parallels**

Genuine parallels of this rim type are lacking from sites west of the Jordan River. Lugenbeal and Sauer (1972: 34) believe that Amiran (1970: 295) parallels this rim type to Judean types but her forms do not resemble this rim type. West Bank sites with stratified Persian period remains, such as Tell Gezer, Tell el-Hesi, and Tell Keisan, do not possess off-set rims. Stern (1982) does not list these bowl rims in his analysis of the Persian period pottery of Palestine.

Similar shards have been found at sites dating broadly throughout the Iron Age. These sites include Bethel (Kelso 1968: pl. 59:17; 60:7); Beth Shan (James 1966: fig. 67:7); Lachish (Tufnell 1953: pl. 99:600); Gerar (Tell Jemmeh) (Petrie 1928: pl. XLVIII:2n, pl. LXV:17); Ramat Rahel, Stratum VA (Aharoni 1962: fig. 11:4; 1964: fig. 16:32-33); and Tell en-Nasbeh (Wampler 1947: pl. 59:1352). Most of these parallels are rather shallow, without carination, or seem to be influenced by Late Assyrian forms (Lugenbeal and Sauer 1972: 34).

Some parallels are known from excavations in Syria (Dornemann 1983: 109-110). Tabbat al Hammam (Area A, level 4) has similar shards, with ware color of orange-tan

and exterior and interior wheel burnishing. Shards were also found in the Amuq at Tell Tayinat and have red to orange-burnished ware. One shard (Area XIII, floor 1) is identical to a shard from the Amman Citadel (Dornemann 1983: no. 578) with fine cream-burnished ware. It should also be noted that black-burnished shards that are common in the Ammonite region are also found at Tell Tayinat (Dornemann 1983: 110).

### Outcurving (everted) Rims

#### **Transjordanian Parallels**

Rims with outcurving rim inflection and grooved walls are also common at Tall Hisban. At Hisban, this type of rim was called the Heshbon Type Bo:6 (Lugenbeal and Sauer 1972: 35-36; nos. 102-149). This rim is well represented in corpus and is found on rather squat and rounded vessels (nos. 107-108, 144) with a short out flaring rim. The rims may have a simple lip (103, 109), thickened and squared lip (nos. 107, 112, 137), or the ridges may extend up onto the rim making a “stepped” lip (nos. 107, 129-130, 142). Overall, the size and thickness of the vessels are consistent and have a thicker ware with hard exterior surface. The surface treatments are most commonly wheel burnish on both interior and exterior, although some may have either only the interior or exterior or none burnished. Exterior burnishing is usually found on the ridges and not between them. The color of the Hisban shards is in the light tan range with some light red, whitish-buff, gray-brown, gray-black interiors with light buff exterior.

Tall Hisban has several examples categorized as Heshbon Type Bo:5 (Lugenbeal and Sauer 1972: 98-101). Heshbon Type Sb:2 may also be added to this bowl form. Several rim profiles from Heshbon Type Bo:6 may be added here (nos. 123-125) but bowl type 6 is generally grooved and will be treated below.

Other sites in Transjordan which have produced examples but which cannot be attributed specifically to Late Iron II or Persian periods include Rujm al-Hanu (V. A. Clark 1983: fig. 3:4-5). The Rujm al-Hanu bowls are wide and shallow with rounded shoulders and flaring rim. Both rims are unslipped but wheel burnished, one with close burnishing and over the whole vessel (no. 5) while the other has widely spaced bands (no. 4). These deep, grooved bowls with outcurving rim inflections are largely typical of the Ammonite region. This bowl is the most common bowl type at Rujm al-Hanu (V. A. Clark 1983: figs. 1:2-6; 3:6, 8-14) and is similar in surface treatment to the Hisban corpus.

At the Amman Citadel, outcurving rims with ungrooved walls correspond to some rims in Shard Profile Types XLVII-XVIX (Dornemann 1983: figs. 44; 56:587, 591, 597-600), especially Type XLVIII (excluding no. 601, see flattened rims). As most of Type XLVII are grooved, these will be discussed below. Most of the rims of Type XLVIII are flaring while only one (no. 600) is pendant. One also has a “stepped lip” (no. 591). Dornemann (1983: 109) cites bowls of Type XLVIII as having low and short sides. The examples are red-burnished (although Dornemann does say that some are tan-burnished but provides no illustrations). The deep, grooved bowls with outcurving rim inflections are largely typical of the Ammonite region. The Amman Citadel has several examples (Dornemann 1983: fig. 56:584-586, 588-590, 592-595). Here, this rim is categorized with its non-grooved partner and is classified as Rim Shard Profile XLVII.

Bowls similar to this type were found at Meqabelein (Harding 1950: pl. XVII:1, 2) and at Adoni Nur (Harding and Tufnell 1953: fig. 21:68) in Ammonite territory.

Similar rims have been found in Phase M at Tall Dayr-‘Alla (Lugenbeal and Sauer 1972: 34) where they are extremely common and at Stratum II, Tall as-Sa‘idiyah (Pritchard 1985: fig. 17:9-10, 13) which dates to the end of the Persian period to early Hellenistic period (Pritchard 1985: 79).

As with offset rims mentioned above, outcurving rims are not well attested in the Moabite region. One example may tentatively come from ‘Ara‘ir (Olavarri 1965: fig. 2:9) because, as previously mentioned, ‘Ara‘ir was believed to have been destroyed by Nebuchadnezzar in 582 BC and not resettled.

Another example comes from the Kerak Plateau (Brown 1991: 199; no. 239). The shard has a beige slip with a simple rim with exterior grooving. It is similar to Type Bo:6 from Tall Hisban but not everted or really rounded (grooving). Brown dated the shard to the Iron II period.

Numerous parallels of the outcurving rim inflection may also be sought from Edomite sites. At Tawilan, these bowls are categorized as Type B (Hart 1995b: 54, 57; fig. 6.7:7). The bowls are quite common here and are mostly undecorated (Hart 1995b: fig. 6.3:1-12), except for two vessels with simple black bands (Hart 1995b: fig. 6.3:7, 12). The vessels have flaring or flat rim profiles with rounded, flat, or “stepped” lips (Hart 1995b: fig. 6.3:2, 9-10). The curve is not too pronounced and follows a straight line.

At Busayrah, Area D (Hart 1995a: fig. 8:11-19; 1995b: 57), the bowls are generally undecorated with two having black painted bands on the rim (Hart 1995a: fig. 8:13, 15) and one with exterior burnishing (Hart 1995a: fig. 8:16). Four whole forms were found; all with flat bases (Hart 1995a: fig. 8:11-13, 17) while vessels at Tawilan had ring bases. The wall profiles from the shards at Busayrah D are similar to those from

Tawilan (compare the sharp carination of Hart 1995a: fig. 8:12, 14, 17 with Hart 1995b: fig. 6.3:3, 8). Other shards with an outcurving rim profile have been found at Busayrah (Bennett 1975: fig. 7:4, 9; Hart 1995b: 57). The shards represent vessels that were deeper than those from Tawilan. Vessels with ring bases (Bennett 1974: fig. 15:3, 5), flat bases (Bennett 1975: fig. 7:4, 9), and a pedestal base (Bennett 1975: fig. 6:6) were found. No pedestal base was found at Tawilan (Hart 1995a: 57).

The Edomite site of Ghrareh has also produced outcurving rim shards (Hart 1987a: fig. 9:1; 1988: fig. 7:3). The shards from Ghrareh are similar in shape to those from Tawilan (compare Hart 1989: pl. 3:1 with Hart 1995b: fig. 6.3:2) with some minor differences (Hart 1995b: 57). The shards from Ghrareh have a thicker curve by the inner rim (Hart 1989: pl. 1:6-9). In addition, the Ghrareh shards have a rounded wall profile and are not as carinated as the Tawilan counterparts. Finally, the Ghrareh shards are more decorated.

The site of Umm al-Biyara has yielded only a few shards (Bennett 1966a: fig. 2:16; Hart 1995b: 57; Oakeshott 1978: pl. 57:2-4). The three latter shards are close parallels to shards from Tawilan (compare Oakeshott 1978: pl. 57:2 with Hart 1995b: fig. 6.3:1; Oakeshott 1978: pl. 57:3 with Hart 1995b: fig. 6.3:9; Oakeshott 1978: pl. 57:4 with Hart 1995b: fig. 6.3:3). None of the shards from Umm al-Biyara are painted.

Other parallels may also be cited from Level IV (late eighth to early sixth centuries BC) and Tell el-Kheleifeh (Pratico 1993: 46-47; pl. 35:7-12).

### **Non-Transjordanian Parallels**

On the West Bank, outcurving bowls possess a long history, reaching back into the tenth and ninth centuries BC and down into the third centuries BC, and are found at



numerous sites. Stern (1982: 94, type A3; 96, type B2) lists this bowl type as having a flat and wide body, a disk base, and an everted, straight ledge-like rim and coming in small and large types. For example, this type of rim has been found at ‘Ain Shems (Grant and Wright 1938: 137; pl. LXVI:7, 11, 16); Ashdod (Dothan 1971: fig. 6:12; Porath 1974: fig. 4:4-5, pl. XII:4); Beth Zur, Stratum III (Lapp and Lapp 1968: fig. 18:1-4); Bethel (Albright and Kelso 1968: pls. 63:12-13; 64:3); En Gedi, Level V (Mazar, Dothan, and Dunayevsky 1966: figs. 8:6; 14:3; 15:1-2); Gerar (Petrie 1928: pls. 48:2<sup>CEJMP</sup>, 3<sup>DMNS</sup>, 8<sup>H</sup>, 49:13<sup>M</sup>, 14<sup>T</sup>); Hazor, Area B, Stratum VI (Yadin, Aharoni, Amiran, Dothan, Dunayevsky, and Perrot 1961: pl. CCXIX:1) and Area A, Stratum V (Yadin, Aharoni, Amiran, Dothan, Dunayevsky, and Perrot 1958: pl. LXIII:9); Jericho (Kenyon and Holland 1982: fig. 203:9); Lachish (Tufnell 1953: pls. 79; 100:608); Mesad Hashavyahu (Naveh 1962: fig. 4:3, 6), Ramat Rahel (Aharoni 1964: fig. 12:6, 9); Samaria, Cistern 7 strip 1 dating to what was termed the Babylonio-Grecian Period (700-300 BC) (Reisner, Fisher, and Lyon 1924: fig. 169:17<sup>BCDEG</sup>, 18<sup>A</sup>, p. 134, fig. 12A:2-3; Crowfoot, Crowfoot, and Kenyon 1957: figs. 11:16; 12a:2-3); Tel Batash (Timnah), Stratum II (seventh century BC) (Kelm and Mazar 1985: fig. 16:4); Tel Mevorakh (Stern 1978: fig. 4:9-10); Tell Beit Mirsim, Stratum A (Albright 1930-31: pls. 65:20-26; 66:3, 7; 1941-43: pl. 21:8, 10, 12, 15, 19); Tell Gezer, Field VII, Stratum IV (Gitin 1990: pl. 31:2-4, 6); Tell en-Nasbeh (Wampler 1947: pls. 55:1247-1260; 56:1275, 1278; 57:1293-1298; 59:1369); and Tell Keisan, Level 5 (Briend and Humbert 1980: pls. 39, 40:1-5, 41:12) and Level 3 (Briend and Humbert 1980: pl. 20:7).

Outside of Palestine an example from Syria comes from Chatal Huyuk (shard b518 from the surface of Area IV) and is black burnished. The upper surface of the rim

has a decoration of incised concentric circles. Similar bowls with a flat to pendant profile (Karageorghis 1967: pl. CXXV:31, 40, 83, 118, 132) or flaring profile (Karageorghis 1967: pl. CXXV:71, 120, 134) have been found in Tomb 3 on Cyprus at Salamis dating to around 600 BC.

Important for the study of the Persian period is the site of Tell Gezer where these bowls were found in stratified Persian period context (Gitin 1990: pl. 31.2). In the study of Syrian pottery by Lehmann (1998), this bowl type was found in Assemblages 3 and 4 (ca. 700-580) and Assemblage 5 (580-540 BC). In Assemblages 3 and 4, the pendant or flat rim profiles were found on platters (Lehmann 1998: 15; fig. 6:11-13). A bowl with a pendant rim was found in Assemblage 5 (Lehmann 1998: fig. 8:1).

#### Straight, Vertical Simple Rims

##### **Transjordanian Parallels**

At Tall Hisban, this vessel corresponds to Heshbon Type Bo:13 (Lugenbeal and Sauer 1972: 36-37; nos. 158-195). The Hisban corpus possesses a wide range of variations in form and surface treatment. Most of the shards have thin sidewalls, simple rims, and ridges below rim on external sidewall, very much like the ones from Tall al-'Umayri. Rim profiles include slightly thickened (nos. 178, 192), rounded (nos. 169-170, 173), or thinned (nos. 163, 168, 189). The walls may be V-shaped (straight-walled flaring) (161, 194-195), inverted hemispherical (178), or slightly carinated (189-192). The ridge is mostly a single one but there may be multiple (194-195). Overall, the surface treatment of these bowls is similar to that of the off-set rim bowls (see above) but with painting. The interior and exterior of most of the bowls have wide wheel burnish while some just have the interior or exterior burnished or no burnishing at all but with a slip.

The burnish contrasts with the surface of the vessel, for example, a burnish of dark brown-black on a brown-orange surface. Slip colors are mostly light red-orange with some metallic gray-brown. One shard was slipped gray-brown but unburnished (179). Painting is found on red burnished surfaces (180-181, 184) with either red bands between two black ones (180) or a white band between two black bands (181, 184).

Three bowls with a simple, upright rim were discovered in the tomb at Adoni Nur (Harding and Tufnell 1953: fig. 21:72-74). All three bowls are relatively V-shaped (“straight-walled and flare up”) with thin fine hard buff ware (but 71 has soft pink ware). The lips of the rims are tapered and an external ridge is seen just below the rim. Two of the shards (72, 74) have ring burnish and one shard (72) has red paint in a design of crow-steps and a row of dots. All three have a step-cut base.

Two undecorated bowls of similar style were found at the tomb at Meqabelein (Harding 1950: pl. XVII:10, 12). These ridged bowls were very similar to those found at the Adoni Nur tomb.

Grave 36 of the cemetery at Tall al-Mazar yielded a whole vessel with a vertical, simple rim and hemispherical wall profile (Yassine 1984: 66; fig. 3:4). The shallow bowl has rounded shoulders and a rounded flat base. The ware is pinkish buff ware with a light red slip. It is probably an early imitation of a metal type.

At the Amman Citadel, the simple rims are categorized as Rim Shard Profiles XI and XII (Dornemann 1983: fig. 54:502-509) and are not ridged.

Two shards from Rujm al-Hanu have plain, upright rims and exterior ridges (V. A. Clark 1983: fig. 3:18-19). The lip on example 18 is tapered and rounded while the lip on the other is more squared and thickened and tilting inward. Both shards have slip on

the exterior and interior but the first shard has yellowish red slip and the latter has light red. The first shard is also wheel burnished and has an applied lug handle/knob below the rim.

The site of Tall as-Sa'idiyah has produced parallels for this vessel as early as the eighth century BC in Stratum VII (Pritchard 1985: 46; figs. 2:21; 3:10). However, little information was provided from Stratum II (Persian period), as only the earlier strata were used. This earlier utilization does show the long length of time these vessels were in use. The vessel was also not ridged.

Very few examples of the simple rim bowl are found in Moab. The ones that are found are dated earlier to the Iron I or Iron II periods. Several shards were found at Saliyeh (Glueck 1934: pl. 20:12-18; cf. pl. 24). Glueck dates these shards to the Iron I period. Two of these were without an exterior ridge (nos. 12-13) while the rest were ridged. One even had multiple ridges (no. 15). The walls are mostly vertical while the rims were slightly inverted (nos. 14, 17) or everted (nos. 15-16). The surface treatment of these shards is quite different than those from Tall Hisban (Lugenbeal and Sauer 1972: 37).

At Dhiban, a simple bowl rim was found (Winnett and Reed 1964: pl. 75:11). It was dated to the Iron II period which the authors date between 900-600 BC. The ware is medium coarse and buff and it is paralleled to an example from Meqabelein (pl. XVII:12) (Winnett and Reed 1964: 76).

The survey conducted by Brown on the Kerak Plateau yielded a shard with a simple rim (Brown 1991: no. 242). It was of a small globular bowl with simple incurved and black burnished rim.

### **Non-Transjordanian Parallels**

Hemispherical bowls with sloping walls are frequent in western Palestine contexts dating to the ninth and early seventh centuries BC. The sharply curving walls are common in the eighth and seventh centuries at sites in western Palestine (Herr 1989: 305; fig. 9.8:27; cf. Yassine 1984: fig. 3.4). The carinated bowl with a simple rim that flares out is common in Cisjordan throughout the Iron Age.

The simple rim bowl with no exterior ridging and hemispherical or sharply curving walls is well known in Cisjordan throughout the Iron and Persian periods [for example, Tell Beit Mirsim, Stratum A (Albright 1943: pl. 15:13), Ramat Rahel (Aharoni 1964: fig. 12:2), Taanach (P. W. Lapp 1970: fig. 5:11), Hazor, Area B, Strata IV-V (Yadin, Aharoni, Amiran, Dothan, Dunayevsky, and Perrot 1958: pls. LXXI:15; CLXXX:9) and Area G, Stratum IV (Yadin, Aharoni, Amiran, Dothan, Dunayevsky, and Perrot 1961: pl. CCLIV:11), Samaria (Crowfoot, Crowfoot, and Kenyon 1957: 153; fig. 18:5), and Megiddo (Loud 1948: 39:11)]. However, the ridged form of this small bowl is probably exclusively a Transjordanian form (Lugenbeal and Sauer 1972: 37; Herr 1989: 305).

### **Flattened Rims**

#### **Transjordanian Parallels**

Angular or horizontal flattened rims and T-shaped rims were completely lacking from the Hisban corpus (Lugenbeal and Sauer 1972) but now are found (Ray 2001: fig. 3.11: 5, 9).

At the Amman Citadel, the angular or horizontal flattened rim profile is termed as Rim Shard Profile LXVI and is labeled as “in-turned” (Dornemann 1983: 112; figs. 44; 58:667-673). Most of the rims are slightly angular, not as angular as those from Tall al-‘Umayri. One example (Dornemann 1983: fig. 58:673) has several grooves or incised lines on the body wall just below the rim. There are no examples of a T-shaped rim from those illustrated at the Citadel.

From the tomb at Sahab (Harding 1948: fig. 3:11-12) there are two examples of complete bowls with rims having an angular flattened rim profile. Both rims have a buff ware with a red slip. While the former has traces of burnishing, the latter has wheel burnishing on the interior. The former bowl also has a pair of knobs applied to the exterior wall.

One example comes from the tomb at Adoni Nur (Harding and Tufnell 1953: 60; fig. 21:60). The complete bowl has an “inturned, anti-splash rim” of red ware. The bowl has a red slip and a step cut base.

Another example comes from the cemetery at Tell el Mazar (Yassine 1984: 66; figs. 3:8; 46:5). The bowl, from Grave 68, has an angular flattened rim (termed “turned over”) with a carinated wall profile and flat disk base. The ware is relatively fine and is burnished with a red slip on the exterior. Its parallels include the example from Sahab and Adoni Nur.

From Tall as-Sa‘idiyah, Stratum VII, (dating to early eighth century BC) an example of an angular flattened rim is found (Pritchard 1985: fig. 2:1). In addition to this rim profile, a T-shaped rim similar to an Iron II form found at Tall al-‘Umayri (D. R. Clark 1991: fig. 4.7:26) was unearthed.

Some angular flattened rims have been found at Tall Safut (Dornemann 1983: 112, no. 5) but remain unpublished.

Several shards come from the fill of the Nabataean Temple Podium at Dhiban (Tushingham 1972: 122; fig. 1:62-65) or from the Iron Age fill below the Hall (Tushingham 1972: 129; fig. 3:51). These shards have angular flattened rim profile. The rims have either a tan or buff ware. The latter shard has a brownish red slip and close wheel burnishing on the interior and exterior. Another example comes from Tomb J5 (Tushingham 1972: fig. 22:5). An example of a T-shaped rim is also found (Tushingham 1972: 122; fig. 1:61) but with two handles. Finally, a lone shard from Balua (Crowfoot 1934: pl. II; fig. 2:13) was found. It had a flattened horizontal rim profile.

From Tawilan, the bowls with an angular or flattened rim profile or a T-shaped rim profile are part of Type D bowls (Hart 1995b: 54, 57; figs. 6.4-6.7) which incorporates both of Oakeshott's types D (without bar handle or ridge below rim) and E (with bar handle or ridge below rim). These rims are termed "triangular-section rims" in the literature. The rest of the Type D category is thickened rims (see below). Only four shards have an angular flattened rim (Hart 1995b: fig. 6.6:3) or horizontal flattened rims (Hart 1995b: figs. 6.4:4; 6.5:3, 7). One shard has simple black bands with slash decoration on the interior and exterior rim (fig. 6.4:4). These rims may also have slips of white or red and/or light burnishing. Another rim which is almost T-shaped has a grooved lip much like the grooved variety from Tall al-'Umayri. The majority of flattened rims have a T-shaped profile (Hart 1995b: figs 6.4:1-3, 6-8; 6.5:2, 4-5, 7-9; 6.7:5-6, 8). The T-shaped rims may be undecorated (figs. 6.4:1; 6.5:2, 8) or have light burnishing on the interior and exterior. Black painted bands also are common (figs. 6.4:2-3, 6, 8; 6.7:5-6, 8)

or with slash lines (fig. 6.5:9). Slips of white and red are also found. Two shards (fig. 6.7:5-6) have bar handles.

At Area D of Busayrah, there is only a flattened rim with a T-shape profile (Hart 1995a: fig. 9:8). A flattened angular horizontal rim was also found (Bennett 1975: fig. 5:6). This shard is of black ware which is indicative of the Persian period at Tall al-‘Umayri but also may be found during the Iron II/Persian period as well (Herr 2006).

The Edomite site of Ghrareh has produced numerous examples of flattened rimmed vessels (Hart 1989: pls. 3:7-13; 4-6:1-17). The examples from Ghrareh are similar to those from Tawilan but seem to have more of an inward curve. In addition, a vessel from Umm al-Biyara (Bennett 1966a: fig. 3:4; Bienkowski 2011: fig. 4.1:17-27) has a T-shaped rim. It is undecorated.

### **Non-Transjordanian Parallels**

Angular flattened rims (or thickened rims inverting at 90°) have been thought to be limited to Transjordan (Dornemann 1983: 112, no. 5; Herr 1989: 305; Herr and Clark 2008: fig. 9.28; Ray 2001: fig. 3.11:5) as there is a lack of these rims attested to Persian period strata at the main sites of Tell el-Hesi, Tell Gezer, Tell Keisan, and Tell en-Nasbeh. However, several possible but uncertain parallels dating to the Iron II period from Cisjordan may be found at Lachish (Tufnell 1953: pl. 80:81-86), Hazor, Area B, Stratum VA (Yadin, Aharoni, Amiran, Dothan, Dunayevsky, and Perrot 1960: pls. LXXXI:17-28; LXXXII:1), Samaria, Period VII (Crowfoot, Crowfoot, and Kenyon 1957: fig. 11:2, 4), and Tell Beit Mirsim, Stratum A (Albright 1943: pl. 20:15, 17). Rims with a T-shaped profile are equally absent from Cisjordanian sites dating to the Persian period but several Iron II period examples may be cited at Lachish (Tufnell 1953: pl. 100:620);



Hazor, Area B, Stratum VA (Yadin, Aharoni, Amiran, Dothan, Dunayevsky, and Perrot 1960: pl. LXXXI:16, 29); and Tell Beit Mirsim, Stratum A (Albright 1932b: pl. 66:4; 1943: pl. 20:13-18).

### Vertical, Simple Rims with Globular Sidewalls

#### **Transjordanian Parallels**

At Tall Hisban, globular bowls with vertical, simple rims are categorized as Heshbon Types Bo:27, 29-31 (Lugenbeal and Sauer 1972: 40-42, nos. 253-272, 274-277; Ray 2001: fig. 6.13:5-6). The category of shards is diffuse, with rims having grooves or ribbing (nos. 253-256, called Type Bo:27a) or simply grooved (nos. 253-256) or plain (nos. 257-275). The grooved rims are similar to the one from Tall al-‘Umayri (Herr 1989: fig. 19.8:22). Some of the plain rims are more elongated than others. The walls are curving and vary in thickness and overall size. Plain rims seem to have a softer ware than the ribbed or grooved rims. The surface treatment also depends on the rim style. Plain rims are mostly slipped and continuously polished with dark red, pink, or light tan colors. Plain rims are also wheel burnished. Ribbed rims are slipped red-orange on the interior and exterior and closely wheel burnished. One ribbed rim (no. 256) has a light tan slip and is unburnished. The grooved rim is unslipped and unburnished. Painting may also occur but the rims are too small to determine. One bowl (Heshbon Type Bo:28) is classified as Assyrian ware and similar to a vessel from Tall al-‘Umayri (Herr 1989: fig. 19.16:7).

The site of Rujm al-Hanu has yielded three shards of this category (V. A. Clark 1983: fig. 3:26-28). The rims are vertical and rounded, either slightly inverted (no. 28) or

everted (nos. 26-27). The walls are curving. Two of the shards are wheel burnished (nos. 26-27) and two have a red slip (nos. 27-28).

As reported by Lugenbeal and Sauer (1972: 40-42), two tombs from Amman have produced several parallel vessels. The first vessel is from Tomb A (Harding 1944: fig. 69:5; pl. XVII:5). The rim is simple and elongated. The vessel has a flat base and pink ware. The vessel has a red slip, wheel burnishing on the interior and exterior, and black and white painted bands on the exterior shoulder. The second vessel is from Tomb B (Harding 1944: fig. 74:48; pl. XVIII:48). It has a shorter rim than the one from Tomb A. There is presence of a red wash to almost the base. It is burnished with black and white bands around the center and traces of black on the rim. It is also of soft pink ware.

The examples from the unstratified remains at the Amman Citadel are several (Dornemann 1983: 111-112; figs. 57:650-651, 654-656; 77:649, 652-653). These shards represent the Rim Shard Profile LXIII. The fabric of most of the shards is tan color with the same surface color. Three of the rims have a groove where the rim joins the body (figs. 57:651; 77:652-653). All the shards have a simple rim and rounded lip but two may have been thickened (fig. 57:651, 654). One shard is black burnished with a light grayish-tan ware (fig. 77:649). Two shards are wheel burnished with slips of brick-red and orange (fig. 57:654-655). Another shard (fig. 57:656) is dark gray with various sizes of sand grits with spaced lines of burnishing, a common feature of late Iron II ceramics. The unburnished spaces between the burnished lines are red-orange but the lines vary from orange to gray-brown. The rims were not found in Sequence I or II at the Citadel. The shards are very similar to some at Tall al-'Umayri (Herr 1989: fig. 19.8:14-22).

One other example from the Amman Citadel was called an “Assyrian period” bowl (Dornemann 1983: 110-111; fig. 55:548). It is classified as Rim Shard Profile XXXVIII. It possesses a gray-brown ware and surface color with interior and exterior wheel burnishing that has unburnished space between the burnished lines.

At Tall Dayr-‘Alla, Glueck found one shard with this rim inflection which he called a jar (Glueck 1951: 457; pls. 42:2; 132:5). The thin shard has a reddish-brown surface and gray core. The exterior and the upper part of the interior have a reddish-brown slip. The shard is burnished horizontally with bands of black paint with creamy-white slip between the black bands.

Glueck found a similar shard at Tell el Mazar (Glueck 1951: 457; pls. 42:3; 132:6). The shard has two horizontal bands of black paint on the exterior over a horizontal burnish of dark reddish-brown slip. Besides this shard, a vessel with similar rim was found in Grave 24 of the cemetery (Yassine 1984: 66; figs. 3:3; 46:2). It has a shallow and flared rim with globular wall profile. Its shape may be derived from a metal proto-type. The vessel is slipped and burnished, with two slight ribs on shoulder. The ware is pink.

Few examples of the simple rim on a globular body have been published from the Moabite region, mostly from Dhiban (Tushingham 1972: figs. 1:67, 69-70; 24:24). The first three are vessels of buff ware with small to medium white grits and white slip. These vessels are similar to some at Tall al-‘Umayri (Herr 1989: fig. 19.8:14-22). The last vessel is termed a “crater” (Tushingham 1972: 161) but should be listed as a bowl. However, at Dhiban, the shards are dated to the Iron II period based on the assumption that Moab was destroyed in the sixth century (Tushingham 1972: 15).

Quite a few examples of this vessel have been at Edomite sites. At Tawilan, these globular bowls are termed “necked bowls” which includes Type N (deep bowls with short necks) and Type M (deep bowls with straight, flaring neck) bowls (Hart 1995b: 54, 58; figs. 6.10-6.14; see also Glueck 1935: pl. 24:1-5, pp 128 ff.). Type M bowls are rare outside Busayrah. Also should be included here are the fine ware “Assyrian bowls” or Types H, J, and K (Hart 1995b: 54, 58; fig. 6.8).

Types N and M are numerous at Tawilan. The rims are mostly similar to those found at Tall al-‘Umayri. Most are everted but some are vertical (figs. 6.10:4, 8; 6.11:3, 10; 6.12:4) and even a few are slightly inverted (figs. 6.11:8; 6.12:3, 5, 12). The majority of lips are rounded or thinned with some being thickened (fig. 6.12:1-5). One rim has a groove on the interior (fig. 6.13:1) while another has several ridges on the exterior (fig. 6.12:10). The bodies of the vessels are typically globular. Some of the vessels have a rather pronounced shoulder (figs. 6.10:8; 6.11:7; 6.13:1-2; 6.14:1). One vessel has a ridge or ridges at the juncture of the rim and body (figs. 6.12:6; 6.14:2).

Four of the vessels (fig. 6.10:1-4) have the normal black-banded decoration on the exterior. These decorated vessels and their undecorated counterparts (fig. 6.10:5-8) are a common vessel at any Edomite site. Other vessels (fig. 6.11) show a more complex decorative plan. The pattern is mostly of a net with diagonal crossed lines (figs. 6.11:1, 4; 6.13:1), dots (fig. 6.12:2-3), or a ladder (fig. 6.13:2). Three of these vessels with complicated designs (fig. 6.11:7-9) are similar to the Type J vessel (compare fig. 6.11:7-9 to fig. 6.8:14, 17). Besides the black paint, red bands are also present (fig. 6.14:3) but red and white paint are usually used in the more complicated patterns. Besides the painting decoration, thumb impressions were also used here (fig. 6.11:2) as well as on Type J

vessels (fig. 6.8:9-10). Some have an exterior white slip under the black paint usually below the shoulder. Some also have a red slip on the interior (fig. 6.12:1), a pink or white slip on the interior and exterior (figs. 6.14:1; 6.11:2; 6.12:14), or a cream slip on the exterior (fig. 6.14:4).

At Busayrah, Area D, the form is uncommon. A single painted form (Hart 1995a: fig. 9:14) was found but could be placed in the fine ware category. It has no parallels at Tawilan. Three other “necked bowls” had been found but dated to the Iron Age (Bennett 1974: fig. 15:4; 1975 fig. 5:11, 13). The first one was handmade with wet smoothing on the interior and exterior. It also had bands of red and black lines on the exterior. The last two are buff ware. The former had red and black lines on the exterior while the latter had a red band on the interior of the rim and a red band with black lines on the exterior.

At Ghrareh, the most common version of this form is either unpainted or painted with black horizontal bands. The forms from Ghrareh are quite similar to those from Tawilan in both form (fig. 6.10:2 and Hart 1989: pl. 10:10) and in simple decoration of bands (fig. 6.10:1-4 and Hart 1989: pl. 10:7). With more complicated decoration, the difference becomes more apparent. At Ghrareh, there is only a single example from Area B with decoration other than bands (Hart 1989: pl. 26:8) whereas at Tawilan there are several (Hart 1995b: fig. 6.11:1-4, 7-10). White and red paint are more commonly used at Ghrareh (Hart 1989: pl. 10:1-2, 4, 6; pl. 11:5-7, 9) than at Tawilan, where it is seen in complicated decorations (fig. 6.11:1-4, 6, 9). Light wheel burnishing is attested at both Ghrareh (Hart 1989: pls. 10:1; 11:3, 12) and Tawilan (fig. 6.11:5) but it is never a major feature.

At Umm al-Biyara, there are two examples of this bowl (Bennett 1966a: fig. 2:10; Oakeshott 1978: pl. 58:4). Both are unpainted with a standard shape. The latter example from Umm al-Biyara is similar to the Heshbon Type Bo:27 (Lugenbeal and Sauer 1972: 41).

### **Non-Transjordanian Parallels**

Parallels from Cisjordan are few and uncertain (Lugenbeal and Sauer 1972: 41) and date generally to the seventh and sixth centuries BC. From Tell Goren (En-Gedi), Stratum V (Mazar, Dothan, and Dunayevsky 1966: fig. 15:11), there is a deep bowl with traces of wheel burnishing and two brown painted bands. From Tell en-Nasbeh (Wampler 1947: fig. 67:1516-1518), a bowl with reddish color and a slight ring burnish is similar in its form and black paint bands. Other examples come from Ashdod (Dothan and Freedman 1967: figs. 37:18-20; 42:3-6); Samaria, Periods VII and VI (Reisner, Fisher, and Lyon 1924: fig. 161:18; Crowfoot, Crowfoot, and Kenyon 1957: figs. 11:22; 14:1); Tell Gezer, Stratum VA (Gitin 1990: pl. 27:19-21); and Tell Keisan, Level 5 (Briend and Humbert 1980: pl. 37:11). The first vessel from Samaria is quite similar to the vessel from the cemetery at Tall al-Mazar (Yassine 1984: 66).

### Thickened Rims

#### **Transjordanian Parallels**

In the ceramic corpus from Tall Hisban, thickened rims make up Heshbon Type Bo:17a and 17b (Lugenbeal and Sauer 1972: 37-38; nos. 211-219). The most widespread type is the symmetrical thickened rim (Type Bo:17b, nos. 211-219). The forms are rather similar. The bowl is relatively shallow with slightly carinated sidewalls and a thickened

rim. Shards 211 and 212 illustrate the characteristic thickening. The size of the vessel and the thickness of the ware vary but the ware is usually soft. Shard 218 is very similar to two shards from Tall al-‘Umayri (Herr 1989: fig. 19.9:13-14).

Additionally, Heshbon Type Bo:26 (Lugenbeal and Sauer 1972: 39-40; nos. 242-252) exhibits rim thickening with a rounded rim and bulbous, or possibly triangular, ridge. Lip profiles vary from square (nos. 242, 244, 248) to round (nos. 245, 250). The ridges are located on the exterior sidewall below the rim inflection point and usually are flattened (no. 251) but maybe considered to a bar handle (no. 250). A knob or handle can be attached to the ridge (no. 248) and grooves may also appear beneath the ridge (no. 244).

The surface treatment includes wheel burnishing on the interior and exterior with slips of dark red, light orange, and light tan. The surface treatment is very similar to bowls with a simple upright rim (Heshbon Type Bo:27; see above). However, paint seems to have been more common. The bar handle (no. 250) has black paint and a white circle surrounding the knob. Numbers 244 and 249 are painted with black bands over a light tan to cream slip. The three painted bands on number 249 are evenly spaced apart.

From Rujm al-Henu, several rims attest to rim thickening (V. A. Clark 1983: 144-145; figs. 1:9-10; 3:22-24; 5:56). The first two shards have a slightly carinated wall profile and similar Heshbon shard no. 219. The latter three shards are similar to Heshbon shard nos. 211, 212, and 214. Two shards (fig. 3:22-23) have dark gray ware and one (fig. 3:24) has a reddish-brown slip. Three other shards (figs. 1:9-10; 3:22) have interior and exterior wheel burnishing while three shards have two shallow, exterior grooves below the rim. The latter shard possesses a distinct groove topped with a short lip and a

triangular ridge below, possibly to hold a lid. Similar rims have also been unearthed at Tall as-Sa'idiyah (Pritchard 1985: fig. 2:2-4, 6, 8, 10).

Forms that have exterior thickening found outside of Ammonite territory come from Tall al-Mazar. The first bowl from Grave 26 (Yassine 1984: 66; figs. 3:2; 46:3) is shallow and carinated. It has a ridged rim, a disk base and is made of dark brown ware with burnishing. Similar shards have been found at Amman C (Harding 1951: fig. 1:8) and Beer-Sheba (Aharoni 1973: fig. 77:5; pls. 64:5-68:1).

Moabite and Edomite parallel forms of gently carinated bowls with square-topped rims (Lawlor 2000: fig. 3.29:31; see also Herr 1989: fig. 19.9:10-16) may be divided into three types. The first type is a slightly widened rim (Herr 1989: fig. 19.9:10-11) with the best parallels from Jordan Valley during the eighth century BC. Tall as-Sa'idiyah (Pritchard 1985: fig. 3:3), an Amman tomb (Dornemann 1983: fig. 32:47), and the Amman Citadel (Dornemann 1983: fig. 55:536) have also produced thickened rims that were slightly widened. The second type of square-topped rim possesses exterior thickening (Herr 1989: fig. 19.9:13, 14) and has similar forms from the Amman Citadel (Dornemann 1983: fig. 55:536), Tall as-Sa'idiyah (Pritchard 1985: figs. 2:4, 8; 10:11), and a Sahab tomb (Dornemann 1983: fig. 32:49). The third type is an interior-thickened rim (Herr 1989: fig. 19.9:15-16) with parallels from Tall as-Sa'idiyah (Pritchard 1985: fig. 3.2) and a Sahab tomb (Dornemann 1983: fig. 55:532). At Busayrah, a similar shard (Bennett 1974: fig. 15:13) was found with knobs and paint.

### **Non-Transjordanian Parallels**

Thickened rims possess several parallels outside of Transjordan. Similar rim forms have been unearthed at Lachish (Tufnell 1953: pl. 99:607; 79:48), Tell Beit Mirsim



(Albright 1932b: pl. 65:27), Tell en-Nasbeh (Wampler 1947: pl. 57:1287), and Tell Goren (Mazar, Dothan, and Dunayevsky 1966: figs. 14:12; 29:7). The gently carinated bowl form with a slightly widened rim (Lawlor 2000: fig. 3.29:31; see also Herr 1989: fig. 19.9:10-11) was found at Jericho (Kenyon and Holland 1982: fig. 197:29) with a similar bowl possessing an interiorly thickened rim (Kenyon and Holland 1982: fig. 198:5).

Rim with an exterior thickened profile also have been found outside of Transjordan. A variant form of Gezer Type 139 (outcurving) is a bowl (Gezer Type 140) with a folded rim (Gitin 1990: pl. 31:5). This type has a Late Iron II parallel (Gitin 1990: pl. 46:4). A parallel form has been found at Tall al-‘Umayri (Herr 1989: fig. 19.16:1) with also Late Iron II parallels (Herr 1989: fig. 19.9:24, 25). Similar bowls of the variant form have been found elsewhere in Transjordan that are dated to Iron II or Persian period context at Cemetery A of Tall al-Mazar (Yassine 1984: fig. 3:8). The first bowl is of dark brown ware, shallow and carinated sidewalls with a folded (ridged) rim, disk base, and burnish. Parallels to this bowl from Tall al-Mazar are from Amman Tomb F (Harding and Tufnell 1953: fig. 21:60), Amman Tomb C (Harding 1951: fig. 1:8), Sahab Tomb B (Harding 1948: fig. 3:12), and Beer-Sheba (Aharoni 1973: fig. 77:5). The second bowl is similar to the first but has burnished red slip on the exterior. Parallels to this bowl are those of the first with the addition of Beer Sheba (Aharoni 1973: pls. 64:5-68:1). In the Gezer corpus, the folded rim is represented in the eighth through the first part of the sixth century B.C. A possible parallel may be found at Tell el-Hesi, Stratum Vd (Bennett and Blakely 1989: fig. 141:21).

## Basins

### **Transjordanian Parallels**

Basins such as the ones found at Tall al-‘Umayri seem to be rare outside of the Ammonite region (Herr 1989: 308) as well as inside of it.

Basins are not attested to from Tall Hisban. However, a number of shards listed as “kraters” may be basins (Lugenbeal and Sauer 1972: pl. X:532-538) but are not exact parallels. These rims match better basin rims from Tall al-‘Umayri than the krater rims from Tall al-‘Umayri. The rims from Tall Hisban are generally everted (nos. 532, 534) similar to the everted type from Tall al-‘Umayri. The other shards from Tall Hisban are more thickened.

Rujm al-Hanu has several close parallels (V. A. Clark 1983: figs. 1:11-13; 3:29) to the ones from Tall al-‘Umayri. The shards have heavy ware and thick gray core with flat everted rims and upright walls. Two of the rims (nos. 13, 29) have two shallow grooves along the top of the rim.

From the Amman Citadel, one basin was published (Dornemann 1983: fig. 57:613). It is similar to one found at Tall al-‘Umayri (Herr 1989: fig. 19.13:1). It has an everted rim and straight sidewall. The wall has several grooves at its midsection and the rim has an applied knob.

### **Non-Transjordanian Parallels**

Few parallel basin forms can be found outside of Transjordan. A shard from Tell Gezer (Gitin 1990: pl. 32:24) possessed an everted flat rim similar Tall al-‘Umayri but was labeled as a krater and dated to the Early Hellenistic period. Other parallels may

include an eighth to seventh centuries BC form found in the casemate wall of the fortress at Kadesh Barnea (Dothan 1965: 140; fig. 5:7) that is similar to a shard from Tall al-‘Umayri (Herr 1989: fig. 19.13:1) as well as a ceramic piece from Megiddo, Stratum III-II (Lamon and Shipton 1939: pl. 18:91).

## Plates and Platters

### **Transjordanian Parallels**

Plates with simple rims have been found at several Transjordanian sites. These sites include Tall Hisban (Lugenbeal and Sauer 1972: 504-515), Amman (Harding 1951: fig. 1:2; Dajani 1966: pl. V:132), Sahab (Harding 1948: fig. 3:1), the Amman Citadel (Dornemann 1983: figs. 52:184; 53:475; 54:481), Tall as-Sa‘idiyah (Pritchard 1985: figs. 10.23: 17: 2), and Dhiban (Tushingham 1972: fig. 2:23). Rujm al-Hanu had several platter shards (V. A. Clark: 1983: 145; fig. 4:35-37) reminiscent of Heshbon Type Sb:1b, with curved sidewalls and rounded rims. The simple rim with an interior groove may be unique to only the Ammonite plateau, at sites such as Tall Hisban (Lugenbeal and Sauer 1972: no. 512), Rujm al-Hanu (V. A. Clark: 1983: 145; fig. 4:36-37), and the Amman Citadel (Dornemann 1983: fig. 54:484). The Adoni Nur tomb also provided a parallel platter shard (Harding and Tufnell 1953: 59).

## Cups and Mugs

### **Transjordanian Parallels**

According to pottery published from Tall Hisban, the cup with a simple rim projecting sharply inward from the shoulder is Heshbon Type Tc:2 (Lugenbeal and Sauer 1972:44-45; no. 281) The ware on the Hisban shard is pink and rather soft with no

indication of slip or burnishing. A parallel form is from Adoni Nur (Harding and Tufnell 1953: fig. 21:78-79, possibly 77, 80) but this shard has a wider shoulder than its rounded base section and the rim protrudes inward and up from shoulder.

The cup with a 45 degree inverted rim and outward-sloping sidewall (Herr 1989: fig. 19.16:20) has parallels from Tall Hisban (Lugenbeal and Sauer 1972: no. 281), a tomb at Sahab (Harding 1948: fig. 4:26, 29), Adoni Nur (Harding and Tufnell 1953: 13-16), and the Amman Citadel (Dornemann 1983: fig. 58:660).

Another type of cup from Tall Hisban is called Heshbon Type Tc:3 (Lugenbeal and Sauer 1972: 44-45; no. 282; unpublished shards 12269 and 12444). This cup has an inward leaning and thickened rim, a bulging neck with an external curved ridge, and an almost vertical sidewall. Several parallel forms of this cup may be found at Rujm al-Hanu (V. A. Clark 1983: 146; figs. 1:27; 4:41; 6:81-82) although three of the four forms (figs. 1:27; 6:81-82) may be holemouth jars. Other sites yielding similar cup shards include Amman (Harding and Henschel-Simon 1944: 70, 75, pl. 17:10; Dajani 1966: 42, pls. 7:47, 129; 8:56-57), an Amman tomb (Dornemann 1983: fig. 34:8-9), and Sahab (Harding 1948: fig. 4:25, 27-28, 30).

A questionable diameter may exclude one of the Hisban shards (no. 282) (Lugenbeal and Sauer 1972:45). The unpublished shard 12269 from locus 47 has parallels from Amman tomb A (Harding 1944: fig. 70:11-12) while unpublished shard 12444 from locus 50 has similar forms from Amman tomb A (Harding 1944: fig. 70:10), Amman tomb C (Harding 1951: fig. 1:11), Sahab tomb B (Harding 1948: fig. 98:24-30), and Jofeh (Dajani 1966: pls. VII:47, 129; VIII:48, 57).

Mugs have also been found at Tall Hisban and Rujm al-Hanu. The Hisban mugs, called Heshbon Type M:1 (Lugenbeal and Sauer 1972: 43; fig. 278-279) and the four shards from Rujm al-Hanu have globular bodies with a vertical and curved neck (V. A. Clark 1983: 145; figs. 1:15; 4:38-40). The Hisban mug (no. 279) was reconstructed with a disk base, a globular body, and a handle rising above the rim.

Parallels to these mugs come from Amman tomb A (Harding 1944: fig. 70:19), Sahab tomb B (Harding 1948: fig. 7:66, 71), and Jofeh (Dajani 1966: pl. V:58). The latter three shards have variations but all shards have in common an inverted rim, a near-vertical neck that is almost as long as or longer than half the length of the vessel, a handle rising slightly above the rim but close to body (the Jofeh shard does not possess a handle), a rounded shoulder producing a globular sidewall profile with an unburnished surface, and a low disk base.

Grave 22 from Tall al-Mazar (Yassine 1984: 75; figs. 4:7; 50:44) yielded what may be a mug but was labeled "cup." The small shard had a slight foot, loop side handle, and a crudely handmade base out of greenish-buff clay.

Mug parallels from Edomite sites come from various locations. Shards sharing similar form were found at Tawilan (Bennett and Bienkowski 1995: 54, 58; fig. 6.9:5-9) and Umm al-Biyara (Oakeshott 1978: pl. 57:12). The Tawilan examples (Type L) are bowls with a single handle and may be a variant of the "Assyrian" bowl. The ware is coarse and decoration is not used. A single loop handle is attached. This form is very common at all Edomite sites and appears throughout Transjordan but seldom in Palestine (Oakeshott 1978: 205).

Two shards from Umm al-Biyara (Bennett 1966a: fig. 3:7, 8) with an outward-sloping rim and a vertical lip have no equivalent at Tawilan. In addition, two more shards from Umm al-Biyara (Bennett 1966a: fig. 2:1, 3) are quite different. They are a wider and more open form with flaring rims and rounded rather than disk bases. Handles project out from the bodies more than it rises above the rim.

Finally, the shards from the site of Ghareh are quite comparable to a shard from Tawilan (fig. 6.9:2). And shards from Tell el-Kheleifeh are the same as those from Umm al-Biyara but differing from the Amman group (Hart 1989: pls. 8:5; 8:11; fig. 6.9:5).

### **Non-Transjordanian Parallels**

West of Transjordan, the cup shares several similar types but no shards share characteristics with the mug. Earlier examples may be found at Nebo (Saller 1965-66: fig. 15:10ff; 31:4), Dhiban (Tushingham 1972: fig. 1:13-14), Tall Dayr-‘Alla (Franken and Kalsbeek 1969: figs. 73:9-10; 75:94-95), Tell en-Nasbeh (Wampler 1947: pl. 44:92), and Ain Shems (Grant and Wright 1938: pl. LXVII:13-14).

## **Kraters**

### **Transjordanian Parallels**

Due to terminology, finding parallel forms for kraters dating to the Persian Period is difficult. Often times, a ceramicist may term a vessel that is called krater here by other names. The most common name is a "holemouth bowl" although sometimes this vessel is also categorized as a jar. Parallels forms will be included here only if the vessel is termed krater or if the vessel possesses distinct features that tend it to be more "krater-like" in appearance.

From Tall Hisban, no kraters were differentiated among the corpus. However, Heshbon Type Bo:26 (Lugenbeal and Sauer 1972: 39-40; nos. 242-252) is very similar in rim profile to kraters from Tall al-'Umayri that it will be included here even though it is not termed "krater" but "holemouth bowl." Rims may be square or flattened (nos. 242, 244, 248) as well as rounded (nos. 245, 250). The most distinctive feature is an external ridge just below the rim. The ridge is generally flattened but may be used as a bar handle (no. 250). Shard 244 has grooves below the ridge.

Many shards were unslipped, unburnished, or had no decoration. Some had red slip (nos. 248, 250) and wheel burnishing (no. 248). Painting was also found. A black cross and a white circle (no. 250) or black bands (nos. 244, 249) were the designs.

Rujm al-Hanu has one example that may fit into the category of krater (V. A. Clark 1983: 144, fig. 3:25) although it is listed as a holemouth bowl. It is paralleled to Heshbon Type Bo:26 above. This rim has a triangular ridge and is undecorated.

At Tawilan (Hart 1995b: 54, 58; figs. 6.15-6.17), kraters were termed as Type F. The more common form (Hart 1995b: figs. 6.15:1-3) is almost a holemouth krater but the rim profile is more vertical. Most sidewalls had an irregular profile (fig. 6.16:1-2, 4) but all were of the same general shape. One krater (fig. 6.17:12) possessed a complex triple rim and a band of denticulation around the shoulder. This vessel is related to another vessel (fig. 6.18) but is undecorated and with handles.

Area D from the site of Busayrah yielded some general corresponding forms (fig. 6.17:8 with Hart 1995: fig. 11:2; fig. 6.15:2-3 with Hart 1995: fig. 11:4). The examples from Busayrah, however, tend to be more upright while the vessels from Tawilan are more incurving at the rim.

The site of Ghrareh also yielded kraters that were similar in general form to those from Tawilan but possessed differences in rim details. At both sites, the usual sidewall profile is a continuous smooth curve from the rim to the base. And, unlike some kraters from Busayrah (Hart 1995: fig. 11:2), rims from Ghrareh are often squared in cross-section (Hart 1989: pl. 13:1-5, 11, 14). Ghrareh rims are also more homogenous when compared to krater rims from Tawilan (figs. 6.16:4; 6.17:11-12).

Finally, one final vessel from Umm al-Biyara may possibly be a krater. This vessel (Bennett 1966a: figs. 2:7; 3:10) is generally thinner near the rim than rims from Tawilan but one example from Tawilan (fig. 6.15:3) may be similar. It should be noted that according to Lugenbeal and Sauer, this vessel from Umm al-Biyara was labeled as a jar (Type Ja:1) and not as a krater.

## Cooking Pots

### **Transjordanian Parallels**

Designating a vessel as the specialized form of cooking pot is based primarily on understanding the function of the vessel. Many archaeologists and ceramists will assign shards to the overall form term of “bowl” since the designation of cooking pot may not be obvious. Only if an archaeologist or ceramist judges the specific function of cooking will the shard be given the name of cooking pot. Due to this judgment call, few sites define and publish shards as cooking pot.

At Tall Hisban, four types of cook pots were differentiated (Lugenbeal and Sauer 1972: 46-49; nos. 291-332). The first type of cooking pot was subdivided into three types. Cooking Pot Type 1a (nos. 291-305) possessed a characteristic rounded sidewall with no neck and an unthickened, grooved rim profile. Often this cooking pot had two



handles, each attached over the ridge of the rim and possibly rising slightly above rim level.

The next three types (Types 1b, 1c, and 3) of cooking pots found at Tall Hisban are very similar, sharing a bulbous rather than grooved rim (nos. 306-307, 308-310, 326-330 plus 332, respectively). Similar to Type 1a, these three cooking pots types are also neckless. A minor groove and ridge below the rounded rim characterizes Type 1b. Type 3, the larger example of Type 1b, has a more significant ridge groove on the side of the rounded rim.

Another cooking pot type is divided into three subdivisions, all sharing an everted, outflaring, and a more closed rim profile. Heshbon Cooking Pot Type 2a (no. 311) has an outflaring and simple rim connecting to a rounded sidewall at a very sharp angle. An oval handle, with a central ridge, is attached on a flattened lip and does not rise above the level of the lip.

Heshbon Cooking Pot Type 2b (nos. 312-313) is known for a small groove on the top of the rim. The two shards of this type are slightly upturned and show remnants of a rounded sidewall.

Heshbon Cooking Pot Type 2c (314-325) is similar to Type 2b but has a more rounded rim profile and no groove on the rim. The rims are more upturned and outplayed than the other types and have a rounded sidewall. Handles are common and rise above rim level.

The fourth type of cooking pot from Tall Hisban is more closed than open (no. 331). Cooking Pot Type 4 may be more correctly designated as a jug than bowl due to the

closed profile and the presence of a long, vertical neck. The rim possesses a slight inward fold.

The wares of the Tall Hisban cooking pots are generally coarse and rough with a sandy texture. The colors may be brick-orange or smoked black. Only Type 4 had a different color of dark brown-black.

Sixteen cooking pot shards dating to the Persian period have been unearthed at Rujm al-Hanu (V. A. Clark 1983: 145; figs. 1:16-17; 4:42-55). The majority of these shards combine Heshbon Types 2b and 2c, producing a neckless, bulbous shard with a slightly flaring or flattened rim, often with a single groove along the lip. Other shards are neckless with a grooved, bulbous rim (similar to Heshbon Type 1c) or shards with an exterior groove (similar to Heshbon Type 3). One shard is a closed form with a curved sidewall and two handles rising above the rim. With its rounded, upturned rim that is thickened on the inside, this rim closely resembles Heshbon Type 1c. Handles generally rise about the rim, joining the rounded sidewall of the body at the shoulder. Ware colors include yellowish red and reddish brown but are predominantly red.

The cooking pot with a rounded sidewall and an unthickened, grooved rim (Heshbon Cooking Pot Type 1a) possesses several parallel forms, especially from southern Transjordan (Lugenbeal and Sauer 1972: 46). Sites include Umm al-Biyara (Bennett 1966a: figs. 3:12; 4:8), a four-handled cooking pot from Tell el-Kheleifeh (Amiran 1970: 300-301), Balu‘ah (Crowfoot 1934: pl. II, fig. 2:4), Tall Dayr ‘Alla (Franken and Kalsbeek 1969: fig. 74:47), and an unspecified site in Edom (Glueck 1935: 135-136; pl. 24:20). A neckless shard with a slightly grooved rim from ‘Ara‘ir (Olavarri

1965: fig. 2:10) may date to the Persian period but 'Ara'ir was believed to have been destroyed by Nebuchadnezzar in 582 BC and not resettled.

### **Non-Transjordanian Parallels**

Several different cooking pot forms have been found west of Transjordan. According to Lugenbeal and Sauer (1972: 46), Heshbon Type 1a was discovered at Tell Goren (Mazar, Dothan, and Dunayevsky 1966: fig. 17:6), Tell en-Nasbeh (Wampler 1947: pl. 48:1024-1025), Ramat Rahel (Aharoni 1964: fig. 20:7), and possibly Tell Beit Mirsim (Albright 1932b: pl. 55:9; 1943: pl. 19:2).

Heshbon Type 1b, 1c, and 3 also have several non-Transjordanian parallels (Lugenbeal and Sauer 1972: 48). The sites include Tell en-Nasbeh (Wampler 1947: pl. 48:1018), Samaria (Reisner, Fisher, and Lyon 1924: fig. 168:9b), and possibly Beth Shan (James 1966: fig. 69:15).

Although unknown in Transjordan (Lugenbeal and Sauer 1972:48), Heshbon Type 2a has several non-Transjordanian parallels. The variety of rims, sidewalls, and handles contained in this cooking pot type is quite large. Parallels include shards from the sites of Kadesh Barnea (Dothan 1965: fig. 5:11), Tell en-Nasbeh (Wampler 1947: pl. 48:1028), Mesad Hashavuyahu (Naveh 1962: fig. 5:1), Tell Goren (Mazar, Dothan, and Dunayevsky 1966: fig. 18:1); Ramat Rahel (Aharoni 1962: fig. 1:23; 1964: fig. 20:8-10), Lachish (Tufnell 1953: pl. 93:460), and Ashdod (Dothan and Freedman 1967: figs. 40:19; 41:12).

Excavations at Non-Transjordanian sites have produced similar shards as Heshbon Type 2b (Lugenbeal and Sauer 1972: 49). The sites include Ramat Rahel (Aharoni 1962: fig. 28:35; 1964: fig. 18:11), Beth Zur (Sellers 1968: fig. 19:3), Gibeah

(Sinclair 1960: pl. 23:3), and Bethel (Kelso 1968: pl. 65:4). Similar but thinner shards have been unearthed at Tell Goren (Mazar, Dothan, and Dunayevsky 1966: fig. 18:4-8), Mesad Hashavuyahu (Naveh 1962: fig. 5:3), Gibeon (Pritchard 1964: fig. 35:2), and Ramat Rahel (Aharoni 1962: figs. 11:24; 28:36-37; 1964: fig. 18:10, 12).

## Mortaria

### **Transjordanian and Non-Transjordanian Parallels**

Parallels of the different types of mortaria are not numerous in Transjordan. The mortaria with smooth sidewalls has been found at Tall Hisban (Lugenbeal and Sauer 1972: 237), with parallels seemingly limited to the Ammonite territory. Mortaria with wavy sidewalls are similar to shards from Tall Hisban (Lugenbeal and Sauer 1972: no. 234) and Tall as-Sa'idiyah (Pritchard 1985: fig. 15:9). Another mortar has been unearthed at Tall Dayr 'Alla but in a context associated with fifth and fourth century BC imported Greek pottery.

One shallow bowl with a footed base and thickened everted rim has been found in Moabite territory (Brown 1991: 204; no. 288). This bowl has been called a "mortaria" but the rim is more rounded and less sharply defined than most mortaria. The mortar possesses pale pink fabric with both the interior and the exterior surfaces having a cream slip. Besides the slip, decoration includes a lightly grooved wavy line beneath the exterior rim, possibly made by movement of the potter's fingertip across the wet clay. Lapp suggested a mid-fifth through third century BC time span for this ceramic vessel (Lapp 1970: 184) based on comparison to Taanach (Lapp 1970: fig. 7:12-13). Unbroken occupational levels (Levels 5-3) dating to the late Iron II period through the Persian period from excavations at Tell Keisan, however, reveals that the mortar may originally

be an earlier form. A mortar has been identified in Level 5 dating to the Iron IIC period (Briend and Humbert 1980: pl. 45:5) and in Level 4 of the (transitional) Iron IIC/Persian period (Briend and Humbert 1980: pls. 28:1; 31:5-6) as well as Level 3 of the Persian period (Briend and Humbert 1980: pl. 20:17-19, 21). Lapp's dating of the Taanach mortar to the fifth century BC has been supported not only by Rast's investigation of Period VIA (1978: fig. 77:7-8) and Period VIB (Lapp 1978: figs. 84:2; 85:9) at Taanach dating to 450-400 BC, but also the fourth century BC parallels from Hazor, Area B, Stratum II (Yadin, *et al.* 1958: pl. LXXIX:17-18, 20, 24) and Area G, Stratum II (Yadin *et al.* 1961: pl. CCLVII:1-10). Other mortaria from Palestinian sites uncovered in a Persian period context come from Tell Gezer, Field VII, Stratum IV (Gitin 1990: pl. 30:1-16) and Field II, Stratum 3 (Dever, *et al.* 1974: pl. 37:3); Ramat Rahel Pit 484 (Aharoni 1964: fig. 12:19, 22); Qadum (Stern and Magen 1984: fig. 5:13-15), and Tell en-Nasbeh Cistern 361 (Wampler 1941: fig. 12:X74).

## **Jars**

### Necked Jars

#### **Transjordanian Parallels**

At Tall Hisban, necked jars are listed as Heshbon Type Ja:9 (Lugenbeal and Sauer 1972: 54-55; nos. 403-448). Heshbon Type Ja:17 (Lugenbeal and Sauer 1972: 55; nos. 456-459) may also be added to this list of necked jars. The necked jars of Type Ja:9 all have a short, sloping neck. Most of the jars have a small everted ("outsplayed") or pointed rim similar to those rims from Tall al-'Umayri. The necks may be ridged (nos. 443-447) or grooved (nos. 428, 433) but most have neither. The grooved jar (no. 428) is very similar to jars from Tall al-'Umayri and may be limited to only the Ammonite

plateau (Herr 1989: 303). The other grooved jar (no. 433) is also similar to forms from Tall al-‘Umayri (Lawlor 1997: fig. 3.15:6; see also Herr 1989: fig. 19.5:15-17; 19.6:11;). Most of the mouth diameters are between 80-100 mm.

The ware is fairly constant in thickness but is generally hard on the surfaces with a dark bluish core. The jars are either unslipped with surface colors of gray or pink or slipped in colors of tan or buff.

The Heshbon Type Ja:17 share a similar sloping neck and pointed rim characteristic of the Type Ja:9 (Lugenbeal and Sauer 1972: 55). The difference lies in a smaller diameter and a pronounced ridge on the neck by the shoulder (no. 458). Except for a shard from Hazor (see below), this jar type is unknown outside of the Amman region.

Aside from Tall Hisban, necked jar forms have been found at other Ammonite sites. From the site of Amman, a jar shard (Dornemann 1983: fig. 41:11) with a very small mouth diameter and triangular folded rims was uncovered. Tomb C at Amman (Harding 1951: fig. 1:39) also produced a form that may have begun in the Persian period (Herr 1989: 307) possessing a thin body wall with sloping, ridged neck and everted rim. It is similar to elongated necked jars from Tall al-‘Umayri and Adoni Nur (Harding and Tufnell 1953: 115). The site of Tall as-Sa‘idiyah (Pritchard 1985: fig. 17-19) has jars with sloping necks, rounded rims, and a vestigial ridge at the bases of the necks.

The tomb from Adoni Nur provides additional examples of necked jars. Two forms which are similar to the Heshbon Type Ja:9 jars were found (Harding and Tufnell 1953: 63; fig. 23:113, 115). The first jar has an almost cylindrical wall profile with cream slip while the latter example is of medium red ware with heavy grooving (ribbing) on the

shoulder. The latter form (no. 115) is similar to a jar from Tall al-‘Umayri (Lawlor 1997: fig. 3.15:7; see also Herr 1989: fig. 19.12:3; Lugenbeal and Sauer 1972: no. 458) which may have begun in the Persian period (Herr 1989: 307). A smaller form of this necked jar possibly may be classified as a decanter (Harding and Tufnell 1953: fig. 22:102-104) and will be discussed below. Another jar fragment from Adoni Nur (Harding and Tufnell 1953: 62; fig. 22:91) is a small jar with a pointed base. The jar has medium buff ware with no slip or decoration. It is similar to the elongated necked shards from Tall al-‘Umayri.

Similar necked jars have discovered at Meqabelein and Tall Dayr-‘Alla. The jars from Meqabelein (Harding 1950: pls. XVI:4; XVII:7) are similar to Heshbon Type Ja:9, although the Hisban ceramics do not have a ridge on the neck (Lugenbeal and Sauer 1972: 54), and to Adoni Nur (Harding and Tufnell 1953: fig. 23:115). The Tall Dayr-‘Alla shards match Meqabelein (pl. XVI:4), Adoni Nur (no. 23:113), and Heshbon Type Ja:9 (Lugenbeal and Sauer 1972: 54).

Five shards necked jars similar to Heshbon Type Ja:9 were found at Rujm al-Hanu (V. A. Clark 1983: fig. 6:73-77). All five shards have an inward sloping neck with an exteriorly thickened rim. Three of the rims have exterior grooving (nos. 74-75, 77) similar to shards from Tall Hisban (Lugenbeal and Sauer 1972: nos. 428, 433, 443). The ware colors are reddish yellow or pink and only one shard (no. 73) has a surface treatment of an exterior white slip.

Finally, several shards from Tall al-Mazar may be categorized as necked jars. Two shards from Grave 69 (Yassine 1984: 73; figs. 4:14; 48:32) have grooved rims, ridged necks, and handles extending from the grooved rim. The vessel bodies have slight

grooving on the shoulder and a shallow disk base. The body has an irregular profile and is made of pink ware, similar to ware found at the non-Transjordanian site of Beer-Sheba (Aharoni 1973: pl. 67:8). Two other jars from Grave 43 of Tall al-Mazar (Yassine 1984: 75; figs. 4:10; 49:43) are small with a rolled rim and disk base. The body is globular with incising on the shoulder. And the ware is a yellowish-reddish color.

A few examples of necked jars have been unearthed at Moabite sites. A shard from Dhiban (Tushingham 1972: fig. 1:5) is quite similar to a jar found *in situ* at Tall al-‘Umayri (Herr 1989: fig. 19.5:23). The jar from Dhiban, however, has a vestigial ridge on its neck and is of gray ware. Tushingham dates this jar and several others (Tushingham 1972: fig. 1:1-4) to the Iron Age that he asserts ended with the destruction of Moab prior to the Persian period. However, all five shards from Dhiban are very comparable to Iron II/Persian period and Persian period forms from Tall al-‘Umayri and Tall Hisban, possibly extending their date later into those periods.

Several necked jar rims were found on the Kerak plateau (Brown 1991: 201, nos. 256, 259; 204, nos. 290-292). The first two shards were dated as Iron IIC period forms but have parallels to the Persian period. The first shard (no. 256) is of plain buff ware with an everted rim. It has a parallel from Tell Beit Mirsim, Stratum A (Albright 1943: pl. 13:3) that is dated to the Iron IIC period. A second shard (no. 259) has a sloping neck and hooked rim which is not well attested. Parallels come only from Tall Hisban (Lugenbeal and Sauer 1972: nos. 403-448, especially 424).

The other necked jar shards from Kerak were dated to the Persian period due to chevrons (deep stamped triangular impressions) on the rims (Brown 1991: 204). All three of the shards (nos. 290-292) have a coarse utilitarian ware. The latter two are very poorly



fired. The last shard has a parallel from Taanach (P. W. Lapp 1970: fig. 6:7; Rast 1978: fig. 85:1).

Necked jars from Edomite sites are not well known. A shard from Umm al-Biyara (Bennett 1966a: figs. 2:11; 4:2-4) is of a sloping-necked jar with a slightly grooved rim. It is a loose parallel to the Heshbon Type Ja:9 (Lugenbeal and Sauer 1972: 54, no. 35) but also may be found at Tell el-Kheleifeh (Glueck 1965: fig. 11).

### **Non-Transjordanian Parallels**

Sites outside of the Transjordanian region have yielded several shards of necked jars. Tell Beit Mirsim and Taanach both possess examples. A jar shard from Tell Beit Mirsim, Stratum A (Albright 1943: pl. 13:3), is of plain buff ware with an everted rim. It is similar to another shard from Kerak (no. 256). The Taanach examples (P. W. Lapp 1970: fig. 6:7; Rast 1978: fig. 85:1) are also similar to a Kerak shard (no. 292). The dating of the Taanach sample is slightly disputed as Lapp proposes a late fifth century date while Rast assigns the pottery to Period VIB, or the second half of fifth century BC.

A tentative parallel to Heshbon Type Ja:9 was found at the site of Samaria (Crowfoot, Crowfoot, Kenyon 1957: fig. 12:23; Hennessy 1970: figs. 13:9; 14:2, 6). More shards were unearthed at Hazor (Yadin, Aharoni, Amiran, Dothan, Dunayevsky, Perrot 1960: pl. C:32). One shard was similar to Heshbon Type Ja:17 and a shard from Stratum VI (Yadin, Aharoni, Amiran, Dothan, Dunayevsky, Perrot 1960: pl. LXXI:9) possessed a resemblance to one discovered at Dhiban (Tushingham 1972: fig. 1:1).

While discussing non-Transjordanian necked jars, a word must be said about the use of chevron decoration. Chevron decoration, or triangular impressions on the rims, has been used at non-Transjordanian sites to date pottery vessels to the Persian period. The

use of chevrons was initially dated between the late seventh and the early fifth century BC according to stratigraphy from Beth-Zur, Lachish, Tell en-Nasbeh, and Ramat Rahel (Lapp and Lapp 1968: 68-69). The range of use was redated between the late sixth century and the fifth century BC (Wampler 1940), which was supported by comparing pottery from Tell en-Nasbeh found in Cistern 370 (Wampler 1941: fig. 2:X7) and Cistern 304 (Wampler 1941: fig. 7:X27) with imported Aegean wares. Lapp and Lapp (1968: 68-69), however, initially dated the range of chevrons to the late seventh through early fifth centuries BC according to stratification at Beth-Zur, Lachish, Tell en-Nasbeh, and Ramat Rahel. Since this last dating, chevron use has been extended to the end of the fifth century BC (Stern 1982: 133-136) with supplemental support from Jerusalem (Lux 1972: fig. 5:1); Tell Anafa (Weinberg 1971: pl. 20A); Khirbet Kefire (Vriezen 1975: fig. 4:24); Tell Gezer, Field VII, Stratum IV (Gitin 1979: pl. 28B:29); and Tell el-Ful, Period III (N. L. Lapp 1981: pl. 65:5-6). The Tell el-Ful pottery possibly predates the Persian period.

In Transjordan, chevrons first were confirmed at Kerak (Brown 1991: 204). These examples, however, may be contrasted with those from Palestine in two ways: 1) in Palestine, chevron impressions are rarely found on closed forms but mainly on open vessels like deep bowls, kraters, and holemouth jars (Stern 1982: 133) and 2) in Transjordan, the deep impressions are more coarse than the majority of triangle-stamped vessels (e.g., Tell el-Ful, Stratum IIIA-B, Lapp 1981: pl 39:1-3).

### Holemouth Jars

#### **Transjordanian Parallels**

At Tall Hisban, holemouth jars are listed as Heshbon Type Ja:1 (Lugenbeal and Sauer 1972: nos. 333-375). The Hisban jars are very similar to ones found at Rujm al-

Hanu (V. A. Clark 1983: 145-146; figs. 1:18-23; 5:56-71). Rims are characteristically thickened and turn sharply inward or flattened (no. 56). A pronounced exterior ridge might appear at the junction of rim and neck (nos. 18-23, 56-70). Several rims (nos. 57-59) were grooved. One shard (no. 71) has a handle below the rim. Slips include white (no. 65) and very pale brown (no. 70) while two shards (nos. 61, 64) show exterior burnishing.

Holemouth jars are not well attested outside of Ammonite territory. As mentioned previously, a reason might be that this form was labeled "krater" instead of "holemouth jar." Included here are shards labeled which were given the holemouth name. The survey of the Kerak Plateau yielded several shards (Brown 1991: 201; pl. 275:260, 268-269). A cylindrical jar (no. 260) has a broad flanged rim with a rounded base. An elongated rim with 2 shallow grooves its horizontal surface adorned another jar shard (no. 268). This rim exhibits similarities with one found at Tall Hisban (Lugenbeal and Sauer 1972: 361). The final rim (no. 269) has a square or flattened profile.

### **Non-Transjordanian Parallels**

Holemouth jars are quite common outside of Transjordan. Parallel forms of the grooved rims found at Rujm al-Hanu were uncovered at En-Gedi (Mazar, Dothan, and Dunayevsky 1966: fig. 21:6, pl. 18.8). The cylindrical jar with rounded base from Kerak parallels shards found at Tell Beit Mirsim, Stratum A (Albright 1932b: pl. 52:3); Khirbet Rabud, Stratum B1 (Kochavi 1974: fig. 8:15); Gibeon (Pritchard 1961: fig. 48:P737); Shechem, Stratum VI (Toombs and Wright 1963: fig. 22:7); Tell Gezer, Field VII, Stratum VIa (Gitin 1990: pl. 18:1-2); and Lachish (Tufnell 1953:fig. 22:7). The squared

rim is similar to ones found at Lachish (Tufnell 1953: pl. 97:543) and Beth-Zur, Stratum III (Sellers, et al. 1968: fig. 15:7).

## Pithoi

### **Transjordanian Parallels**

The bulbous rim of the neckless pithos is common at Tall Hisban (Lugenbeal and Sauer 1972: 52-53; nos. 376-388) and make up Heshbon Type Ja:2 (a, b). The profile of the rims is very similar to those from Tall al-‘Umayri. The rims are round and thick protruding above and below the line of the wall. A variant form (Ja:2b, no. 388) is flattened on top with a square lip. An indentation may be sometimes be found just below the rim on the shoulder of the vessel (nos. 377, 384, 387). The walls of the pithos usually have heavy and coarse ware with slipping. Due to the coarseness of the ware, the slip is badly worn. The walls may be ridged (no. 383) or incised (no. 386) much like the examples from Tall al-‘Umayri. The walls may be reconstructed (based on whole parallels) with a wide curving shoulder, two handles, and an elongated body tapering to a pointed (stump) base.

Similar pithos rims have also been found at Rujm al Hanu (V. A. Clark 1983: figs. 1:24; 6:72). The jars are neckless with thickened, bulbous rims and heavy ware. The first shard has a ridge on the shoulder of the wall while the latter has a groove on the rim. The second shard also has a very pale brown slip.

At the Amman Citadel, the bulbous rim profile is termed Shard Profile Type LX (Dornemann 1983: fig. 44). Several shards possess this rim profile (Dornemann 1983: fig. 57:633-635, 638-645). Some of the shards exhibit the incising (no. 635) and the ridging (no. 634) found on the shards from Tall al-‘Umayri and Tall Hisban. Some of the

Amman Citadel shards had a small groove just below the lip of the rim (nos. 641-643) that is not found on shards from the other sites (except possibly from Tall Hisban, no. 385).

A whole vessel from Balu'ah (Crowfoot 1934: 82; pl. III, figs. 1-2) is an excellent parallel to the pithos rims found in the Ammonite region. The rim is most similar to one shard from Tall Hisban (no. 387) although the thickened part of the rim is similar to another shard (no. 386). The ware of the vessel has a gray color with the surface covered by a pale drab slip. The vessel was produced on a wheel in three sections; joins are evidenced by a groove by the upper attachment of the handles and a "waist" lower the vessel wall. The two handles were attached to the vessel after the three sections were joined together. The knob base is hollow. Ribbing is evidenced between the handles and other places on the vessel wall. Crowfoot estimated the date of the vessel between the Early Iron Age to the Persian-Hellenistic period.

Bulbous rimmed pithos were also recovered during the Kerak survey dating to the Persian period (Brown 1991: 204; nos. 293-297) as well as to the Iron II period (Brown 1991: 201; nos. 261-267). The Iron II shards are included here because of their parallels to the corpus at Tall Hisban. The Persian period shards have a thick ware. One shard (no. 293) has a thick, upturned rim similar to one from Tall al-'Umayri (Lawlor 1997: fig. 3.22:1). Brown thinks this form is derived from the angular "sausage jar" of the Iron II period. A variant of the previous rim has a peaked rim (no. 294). Two of the shards (nos. 296, 297) have a sloping, horizontal bulbous rim. Brown quite correctly sees the origin of these rims in Iron II period. The first shard (no. 296) is very similar to three shards from Tall al-'Umayri (Low 1991: fig. 8.19:2; see also Herr 1989: figs. 19.5:28; 19.12:14).

The examples from Kerak dating to the Iron II period (Brown 1991: 201; nos. 261-267) are quite similar to the Persian period shards. The rims are thick and rounded and probably sit atop large neckless storage vessels. Several shards have parallels to the Tall Hisban shards. The upturned rim (no. 261) is similar to one from Tall Hisban (Lugenbeal and Sauer 1972: no. 376). Several of the Kerak rims have three ridges (grooves) on the rim (nos. 264-265; see Lugenbeal and Sauer 1972: 385). Another shard has ridging on the shoulder (no. 266; see Lugenbeal and Sauer 1972: nos. 377, 383, 385-386).

### **Non-Transjordanian Parallels**

Bulbous pithoi are a common pottery form outside of Transjordan. An upturned rim from Kadesh-Barnea (Dothan 1965: fig. 6:14) is similar to a Kerak shard (Brown 1991: no. 261) while a horizontal rim with a notched shoulder from Tell el-Ful Period III (Sinclair 1960: pl. 23:15) is reminiscent of another Kerak shard (Brown 1991: no. 267). Thick and upturned rims come from Shechem, Stratum V (P. W. Lapp 1970b: fig. 3:4); Tell Gezer, Field II, Stratum 3 (Dever et al. 1974: pl. 37:12); Mugharet Abu Shinjeh (Lapp and Lapp 1974: pl. 18:5); Tell el-Hesi (Coogan 1975: fig. 8:12); Tell Qasile (Maisler 1951: fig. 13:e); Shavei Zion (Prausnitz, Avi-Yonah, and Barag 1967: fig. 11:12) and Mesad Hashavyahu (Naveh 1962: fig. 6:15) while the site of Taanach (Rast 1978: fig. 81:3) yielded thick and rounded rims. Peaked rims were found Taanach (P. W. Lapp 1970: fig. 4:4; Rast 1978: fig. 80:5) and Tell Keisan, Level 3 (Briend and Humbert 1980: pl. 18:1).

Sloping, horizontal, and simple bulbous rims were unearthed at Tell Gezer, Field II, Stratum 3 (Dever et al. 1974: pl. 37:25) and Hazor, Area G, Stratum II (Yadin et al

1961: pl. CCLVII:29), with an earlier variant from a transitional Iron IIC-Persian period layer at Tell Keisan, Level 4 (Briend and Humbert 1980: pl. 25:7). Similar rims were found on cylindrical storage jar from Tell Keisan, Level 5 (Briend and Humbert 1980: pl. 25:7) and Level 4 (Briend and Humbert 1980: pls. 25:8; 27:2-3); Taanach (Rast 1978: fig. 81:1; see also P. W. Lapp 1970: fig. 4:5); and Shechem (P. W. Lapp 1970: fig. 3:5).

### Amphora/Amphoriskos

#### **Transjordanian Parallels**

A close parallel of the amphora from Tall al-‘Umayri is from Amman tomb (Dornemann 1983: fig. 40:19-20). This vessel dates to the eighth through seventh centuries BC.

Several amphorae have been found in graves at the site of Tall al-Mazar (Yassine 1984: 74-75; figs. 4:11-12; 5:1-6). Two vessels (nos. 2-3) have a ridged rim, ovoid body, and a disk base. Other rims include a pushed rim (no. 6), a bow rounded rim (no. 1), and a rolled rim (no. 5). In addition to the disk base, a narrow rounded base (no. 6), a wide bottom base (no. 1), and pointed bases (nos. 4, 11-12). Painted bands of dark brown decorate two vessels (nos. 11-12). Wares include light-to-medium buff and gray colors. Variant parallels of the ridged rim and disk base come from Nimrud, dating to the Late Assyrian Period (Lines 1954: XXXIX, I); Tell en-Nasbeh, dating to 600 BC (Wampler 1947: pl. 27:447); Meqabelein, dating to the latter half of the seventh century (Harding 1950: pl. XVI:4-5); Tell Keisan (Briend and Humbert 1980: pl. 37:10); and Adoni-Nur (Harding and Tufnell 1953: 62, figs. 22, 89-90).

An amphoriskos was additionally discovered at Tall al-Mazar (Yassine 1984: figs. 4:9; 47:24). Although the handles were broken, they seem to extend from the ridge to the

shoulder. The vessel had a long, rolled ridge rim and a disk base, with light red band paint and a burnished yellow slip. The amphoriskos fits into pottery assemblages of from Sahab B (Harding 1948: pl. XXXV:9), Megiddo (Lamon and Shipton 1939: pls. 2:20; 9:3), and Tell Beit Mirsim (Albright 1932b: 68: 31).

One amphora was found on the Kerak Plateau (Brown 1991: 202, no. 274). It is without handles, which appears to be an influence from Assyrian pottery. Parallels to this vessel are from an Adoni Nur tomb (Harding and Tufnell 1953: fig. 22:89-90) and a Meqabelein tomb (Harding 1950: pl. XVI:4-5).

## **Jugs**

### Various Rim Profiles

#### **Transjordanian Parallels**

Excavations at the site of Tall Hisban unearthed several jugs. The most prevalent rim profile is triangular with an everted (pendant) rim. This rim type was categorized as Heshbon Type Ju:2b, Heshbon Type Ju:7, and Heshbon Type Ju:10 by Lugenbeal and Sauer (1972: 474-475, 491-492, 495-497). Unfortunately, description of the jugs is lacking from the publication.

Other Ammonite sites have yielded jug forms. The site of Rujm al-Hanu yielded jug rims similar to two of the types from Tall Hisban. One set of rims (V. A. Clark 1983: 146; figs. 1:25-26; 6:76-78) is similar to Heshbon Type Ju:7. The rims have an everted neck with a thickened rim. Most of the rims do not have a ridge, except for one (fig. 6:76). One has a red wheel burnished slip (fig. 6:78).

The second set of rims (V. A. Clark 1983: 146; fig. 6:79-80) is similar to Heshbon Type Ju:10. The two rims have an everted rim with external thickening and a handle from



the rim to the neck. Besides Tall Hisban, a parallel may also be found at Amman (Harding and Henschel-Simon 1944: 71, pl. 17024; Harding and Tufnell 1953: 63, fig. 23:116) as well as at the non-Transjordanian sites of Tyre (Bikai 1978: fig. 3:6) and Ashdod (Dothan and Freedman 1967: figs. 39:6; 40:12) although the Ashdod shard dated to the eighth century BC.

Excavations around the Amman area have uncovered several jug types. One type from the Amman Citadel (Dornemann 1983: fig. 57:620) has a triangular, everted rim. It is similar to Heshbon Type Ju:2b, but without the small ridge on the neck. The Citadel also yielded a jug with a very small mouth with an incurving rim (Dornemann 1983: fig. 59:724) similar to a Tall al-‘Umayri form (Herr 1989: fig. 9.12:24) A wide-mouth jug (Dornemann 1983: fig. 57:619) with a flaring neck and triangular rim, reminiscent of a shard from Tall al-‘Umayri (Herr 1989: fig. 19.6:19), also came from the Citadel. Triangular rims are similar to early Hellenistic forms (Herr 1995: 618; 1997: 245).

A small juglet (called a "dipper juglet") was also found in the Amman area (Dornemann 1983: fig. 38:7-8). It has a relatively high neck with a slightly thickened rim. From tombs at Sahab (Dornemann 1983: fig. 37:21) and Amman (Dornemann 1983: fig. 37:201), jugs with a pinched rim and with multiple ridges were found.

Tomb C from Amman yielded a wide-mouthed jug (Harding 1951: fig. 1:26-27) similar to one from Tall al-‘Umayri (Herr 1989: fig. 9.12:23) with a parallel form from Jofeh (Dajani 1966: pl. VI:5A; VII:5, 19; VIII:7).

Several fragments of jugs and juglets were also unearthed in graves from the site of Tall al-Mazar (Yassine 1984: 71-73; figs. 3:9-10, 18-23; 4:1-3). Bases included disk (figs. 3:9-10; 4:1, 3), flat and convex (fig. 4:2), and rounded (fig. 3:18, 20-23). One jug

(fig. 4:1) possessed a ridged rim with a long neck and a loop handle extending from the lip. It is similar to a jug from Amman (Harding and Tufnell 1953: fig. 22:102) and Megiddo (Lamon and Shipton 1939: pl. 2:67). A similar jug with a ridged rim and loop handle but with a hemispherical profile is similar to other forms from non-Transjordanian sites of Ta'anek (Lapp 1970: fig. 6:45), Megiddo (Lamon and Shipton 1939: pl. 2:68), Atlit (Jones 1933: 92; fig. 71, pl. 21:819), and Gezer (Macalister 1912: pl. 186:2), with the latter coming from a fifth to fourth century BC deposit. The characteristics of a ridged rim and a loop handle seem to be prevalent on many jugs and juglets although a rolled rim was found on one juglet (fig. 4:3). In addition to the hemispherical wall profile, other profiles included globular and cylindrical. The cylindrical juglet (fig. 3:19) with some slight horizontal ribbing has a parallel form from Amman (Harding 1951: 38:20). Two "drop-shaped" juglets (fig. 3:20-21) with a ridged rim and a handle extending from the rim to the sidewall of the body are similar to examples from Amman (Harding 1945: 74, fig. 64; 1951: fig. 1:29, pl. 1:19).

Shards from Tall al-Mazar had several ware colors. They included pink (pink-white to pink-buff), gray to gray black, red-yellow to red-brown, and yellow. Ribbing, burnishes, and (reddish) slips decorated several vessels.

### **Non-Transjordanian Parallels**

Several non-Transjordanian sites have parallel forms to shards found in graves at Tall al-Mazar. A jug with a cylindrical, slightly ribbed body and ridged rim (Yassine 1984: fig. 3.19) is similar to shards from Tell en-Nasbeh (Wampler 1947: pl. 41:790); Ain Gedi (Mazar, Dothan, and Dunayevsky 1966: pl. XXXIII:14, fig. 30:4), Lachish (Aharoni 1975: pl. 47:27), and Beer-Sheba (Aharoni 1973: pl. 69:20). Another vessel

with a globular body and ridged rim (Yassine 1984: fig. 3:18) has assignable parallels to Beer-Sheba (Aharoni 1973: pl. 62:128), Tell Beit Mirsim (Albright 1943: 68:31), Tell en-Nasbeh (Wampler 1947: pl. 42:852), Megiddo (Lamon and Shipton 1939: pl. 44:55), and Lachish (Tufnell 1953: 35 with tomb 106 dating between 670-580 BC). Finally, a different globular jug with a disk base (Yassine 1984: fig. 3:9) is similar to one found at Tell en-Nasbeh (Wampler 1947: pl. 41:800) while a jug shard with a flaring neck and simple rim from Ashdod (Dothan 1971: fig. 41:23) is similar to a shard from Tall al-‘Umayri (Herr 1989: fig. 19.6:22-23).

## Decaners

### **Transjordanian and Non-Transjordanian Parallels**

Excavations at the site of Rujm al-Hanu unearthed one decanter (V. A. Clark 1983: 146; fig. 8:101). The exterior grooving on the rim is similar to the jug form at Tall Hisban called Heshbon Type Ja:9f (Lugenbeal and Sauer 1972: pl. 8:448; Lamon and Shipton 1939: pl. 10:39). The decanter had two handles extending from the midpoint of the upright neck to the shoulders. The maximum diameter of the vessel was located above the ring base, giving the vessel a bag-shaped appearance. It also had a white slip with widely spaced wheel burnishing.

Graves from Tall al-Mazar have given several examples of decaners (Yassine 1984: 73; fig. 4:4-6). The decaners generally had ridged necks, carinated shoulders, and handles extending from the ridged neck. The rims were pushed (fig. 4:6), splayed and cut off (fig. 4:5), or bowed (fig. 4:4) while wall profiles were ovoid (fig. 4:6) to globular (fig. 4:4) and bases were ring bases. A pinkish-red slip or burnish decorated the latter two decaners while the first example had a reddish-brown burnish. Several Transjordanian

parallels, including shards from Adoni-Nur (Harding and Tufnell 1953: no. 102), Sahab (Harding 1948: fig. 6:56-57), Amman (Harding 1945: fig. 71:29), and non-Transjordanian parallels, including shards from Tell en-Nasbeh (Wampler 1947: pls. 43-52; 69:735), Ain Jadi (Mazar, Dothan, and Dunayevsky 1966: pl. XVII:2, fig. 31:2), Samaria (Crowfoot, Crowfoot, and Kenyon 1957: fig. 22:3), Tell Keisan (Briend and Humbert 1980: pl. 37:1), Lachish (Tufnell 1953: 35; Aharoni 1975: pls. 44:17, 25-26; 49:5; 50:3, 5, 16), Hazor (Yadin 1961: pl. LXXXVII:4, 5), Shechem (Wright 1965: fig. 88), and Megiddo (Lamon and Shipton 1939: pl. 44:55), exist for these three decanters.

## Alabastrons

### **Transjordanian and Non-Transjordanian Parallels**

Other alabastrons dating to the Persian period have been found in the graves at the site of Tall al-Mazar (Yassine 1984: 69-71; figs. 3:5, 11-17; 46:8-11; 47:12-15). The bodies of the alabastron may be wide and broadened in the center (for example, fig. 3:5) but most bodies are narrow and elongated (for example, fig. 3:11-17). Both body types date to sixth to fourth centuries BC (Yassine 1984: 69). The wide disk-shaped rim flares out, with occasionally a ridge appearing on it (for example, fig. 3:12). Two knob handles may appear on the body below the neck (for example, fig. 3:5, 16). Bases are usually rounded.

Ware colors include reddish yellow, pink, and gray. The vessels often have a slip, with colors ranging from white to pinkish white and pink to red. Vertical burnishing is also sporadically present.

Parallel vessels like those from Tall al-Mazar have been found in Jordan, Palestine, Syria, Lebanon, Egypt, and Mesopotamia. Most vessels come from a clear

stratigraphic context showing a distribution from the end of the seventh to the end of the fifth centuries BC. Sites include Babylon (Reuther 1926: 35; fig. 44b), Nineveh (Campbell and Mallowan 1932: pl. 74:19), Nimrud (Oates 1959: pl. 38:88, 90), Tell Halaf (Von-Oppenheimer 1962: pl. 59:11), Meqabelein (Harding 1950: pl. 16:12-18; 1951: figs. 1, 12, 14; Harding and Tufnell 1953: fig. 22:94-99), Gibeon (Pritchard (1964: fig. 34:14), Gezer (Macalister 1912: pl. 187:2), Abu-Gosh (Abel 1921: 97-102), Deve Hüyük (Moorey 1980: fig. 4:32), Tell el Ful (Macalister 1915: pl. 21:1), Tell en Nasbeh (Wampler 1947: pl. 75:1720), Adoni-Nur (Harding and Tufnell 1953: fig. 23:126-127), Sahab (Ibrahim 1975: pl. XXXI:1), and Balatah (Stern 1980: fig. 10:8).

## Flasks

### **Transjordanian and Non-Transjordanian Parallels**

One parallel flask dating to the Persian period has been found in a grave at Tall al-Mazar (Yassine 1984: 73-74; figs. 4:13; 48:33). The rim is rolled over and the globular body has a pair of loop handles. The ware is heavy ware with yellowish-red burnish. Similar forms of this flask have been discovered at Neirab (Abel and Barrois 1927: pl. LIV:53) and Deve Hüyük (Moorey 1980: fig. 3:23 except the base is a disk).

## REFERENCE LIST

- Abel, A., and Barrois, A. G.  
1927 Fouilles de l'Ecole Archeologique Francaise de Jerusalem Effectuees a Neirab du 12 September au 6 November. *Syria* 9: 187-206, 303-319.
- Abel, F. M.  
1921 Decouverte d'un tombeau Antique a Abou-Ghosh. *Revue Biblique* 30: 97-102.
- Abu Dayyah, A.; Greene, J.; Hassan, I.; and Suleiman, E.  
1991 Archaeological Survey of Greater Amman, Phase 1: Final Report. *Annual of the Department of Antiquities of Jordan* 35: 361-395.
- Abu Ghanimeh, K.  
1984 Abu Nseir Excavation. *Annual of the Department of Antiquities of Jordan* 38: 305-310.
- Ackroyd, P. R.  
1990 The Written Evidence for Palestine. Pp. 207-226 in *Achaemenid History IV, Centre and Periphery: Proceedings of the Groningen 1986 Achaemenid History Workshop*, ed. H. Sancisi-Weerdenburg and A. Kuhrt. Leiden: Nederlands Instituut voor het Nabije Oosten.
- Aharoni, Y.  
1962 *Excavations at Ramat Rahel: Seasons 1959 and 1960*. Serie archeologica 2. Rome: Centro di Studi Semitici, University of Rome.  
1964 *Excavations at Ramat Rahel II: Seasons 1961 and 1962*. Serie archeologica 6. Rome: Centro di Studi Semitici, University of Rome.  
1975 *Investigations at Lachish, the Sanctuary and the Residency (Lachish V)*. Publications of the Institute of Archaeology 4. Tel-Aviv: Institute of Archaeology, University of Tel Aviv.
- Aharoni, Y., ed.  
1973 *Beer-Sheba I: Excavations at Tel Beer-Sheba, 1969-1971 Seasons*. Publications of the Institute of Archaeology 2. Tel Aviv: Institute of Archaeology, Tel Aviv University.

- Aharoni, Y., and Amiran, R.  
 1958 A New Scheme for the Subdivision of the Iron Age in Palestine. *Israel Exploration Journal* 8: 171-184.
- Albright, W. F.  
 1932a An Anthropoid Clay Coffin from Sahab in Transjordan. *American Journal of Archaeology* 36: 295-306.  
 1932b *The Excavation of Tell Beit Mirsim I: The Pottery of the First Three Campaigns*. Annual of the American Schools of Oriental Research 12. New Haven, CT: American Schools of Oriental Research.  
 1943 *The Excavation at Tell Beit Mirsim III: The Iron Age*. Annual of the American Schools of Oriental Research 21-22. New Haven, CT: American Schools of Oriental Research.  
 1960 *The Archaeology of Palestine*. 5<sup>th</sup> ed. Harmondsworth: Penguin Books.  
 1986 Notes on Ammonite History. Pp. 503-509 in *The Archaeology of Jordan and Other Studies: Presented to Siegfried H. Horn*, ed. L. T. Geraty and L. G. Herr. Berrien Springs, MI: Andrews University.
- Amiran, R.  
 1970 *Ancient Pottery of the Holy Land: From Its Beginning in the Neolithic Period to the End of the Iron Age*. New Brunswick, NJ: Rutgers University.  
 1972 Achaemenian Bronze Objects from a Tomb at Kh. Ibsan in Lower Galilee. *Levant* 4: 135-138.
- ‘Amr, A.-J.  
 1980 *A Study of the Clay Figurines and Zoomorphic Vessels of Trans-Jordan During the Iron Age, with Special Reference to Their Symbolism and Function*. Unpublished Ph.D. Dissertation, University of London, England.
- Avigad, N.  
 1976 *Bulae and Seals from a Post-Exilic Judean Archive*. Qedem 4. Jerusalem: The Hebrew University of Jerusalem, The Institute of Archaeology.  
 1997 *Corpus of West Semitic Stamp Seals*. Jerusalem: Israel Academy of Sciences and Humanities.

Barghouti, A. N.

- 1982 Urbanization of Palestine and Jordan in Hellenistic and Roman Times. Pp. 209-229 in *Studies in the History and Archaeology of Jordan I*, ed. A. Hadidi. Amman: Department of Antiquities.

Bartlett, J. R.

- 1979 From Edomites to Nabataeans: A Study in Continuity. *Palestine Exploration Quarterly* 111: 53-66.

- 1982 Edom and the Fall of Jerusalem, 587 B.C. *Levant* 14: 2-24.

Beit-Arieh, I.

- 1996 Edomites Advance into Judah. *Biblical Archaeology Review* 22: 28-36.

Ben-Tor, A.; Bonfil, R.; Garfinkel, Y.; Greenberg, R.; Maeir, A. M.; and Mazar, A.

- 1997 *Hazor V: An Account of the Fifth Season of Excavation, 1968*. Ed. A. Ben-Tor and R. Bonfil. Jerusalem: Israel Exploration Society.

Bennett, C-M.

- 1966a Fouilles d'Umm el Biyara: Rapport Préliminaire. *Revue Biblique* 73: 372-403.

- 1966b Notes and News. *Palestine Exploration Quarterly* 98: 123-126.

- 1973 Excavations at Buseirah, Southern Jordan, 1971: A Preliminary Report. *Levant* 5: 1-11.

- 1974 Excavations at Buseirah, Southern Jordan, 1972: Preliminary Report. *Levant* 6:1-24.

- 1975 Excavations at Buseirah, Southern Jordan, 1973: Third Preliminary Report. *Levant* 7: 1-19.

- 1977 Excavations at Buseirah, Southern Jordan, 1974: Fourth Preliminary Report. *Levant* 9: 1-10.

- 1978 Some Reflections on Neo-Assyrian Influence in Transjordan. Pp. 165-171 in *Archaeology in the Levant: Essays for Kathleen Kenyon*, ed. R. Moorey and P. Parr. Warminster, England: Aris & Phillips.

- 1982 Neo-Assyrian Influence in Transjordan. Pp. 181-187 in *Studies in the History and Archaeology of Jordan I*, ed. A. Hadidi. Amman: Department of Antiquities.



- 1983 Excavations at Buseirah (Biblical Bozrah). Pp. 9-17 in *Midian, Moab, and Edom: The History and Archaeology of Late Bronze and Iron Age Jordan and North-West Arabia*, ed. J.F.A. Sawyer and D.J.A. Clines. Journal for the Study of the Old Testament Supplement Series 24. Sheffield: Journal for the Study of the Old Testament.
- 1984 Excavations at Tawilan in Southern Jordan, 1982. *Levant* 16: 1-23.
- Bennett, C-M., and Bienkowski, P., eds.  
 1995 *Excavations at Tawilan in Southern Jordan*. Oxford: University.
- Bennett, W. J., and Blakely, J. A.  
 1989 *Tell el-Hesi: The Persian Period (Stratum V)*. Winona Lake: Eisenbrauns.
- Benz, F. L.  
 1972 *Personal Names in the Phoenician and Punic Inscriptions*. Rome: Biblical Institute.
- Berge, D. R., and Lloyd, A. W.  
 2002 Field H: The Southwest Acropolis. Pp. 117-134 in *Madaba Plains Project – ‘Umayri 5: The 1994 Season at Tall al-‘Umayri and Subsequent Studies*, eds. L. G. Herr, D. R. Clark, L. T. Geraty, R. W. Younker, and Ø. S. LaBianca. Berrien Springs, MI: Institute of Archaeology/Andrews University.
- Bermingham, J.  
 1963 The Development of the Fibula in Cyprus and the Levant. *Palestine Exploration Quarterly* 95: 80-112.
- Bienkowski, P.  
 1990a The Chronology of Tawilan and the “Dark Age” of Edom. *Aram* 2 (1 & 2): 35-44.  
 1990b Umm el-Biyara, Tawilan and Buseirah in Retrospect. *Levant* 22: 91-109.  
 1995a The Architecture of Edom. Pp. 135-143 in *Studies in the History and Archaeology of Jordan V: Art and Technology Throughout the Ages*, ed. K. ‘Amr, F. Zayadine, and M. Zaghoul. Amman: Department of Antiquities.  
 1995b Observations on Late Bronze-Iron Age Sites in the Wadi Hasa, Jordan. *Levant* 27: 29-37.

- 2001 The Persian Period. Pp. 347-365 in *The Archaeology of Jordan*, ed. B. MacDonald, R. Adams, and P. Bienkowski. Levantine Archaeology 1. Sheffield: Sheffield Academic.
- 2002 *Busayra: Excavations by Crystal-M. Bennett 1971-1980*. Oxford: Oxford University Press.
- 2011 *Umm al-Biyara: Excavations by Crystal-M. Bennett in Petra 1960-1965*. Oxford: Oxbow Books.
- Bienkowski, P. (ed.)  
 1991 *Treasures from an Ancient Land: The Art of Jordan*. Liverpool: National Museums & Galleries on Merseyside/Stroud: Alan Sutton.
- Bikai, P. M.  
 1978 The Late Phoenician Pottery Complex and Chronology. *Bulletin of the American Schools of Oriental Research* 229: 47-56.
- Blakely, J. A., and Horton, F. L., Jr.  
 1986 South Palestinian Bes Vessels of the Persian Period. *Levant* 18: 111-119.
- Boling, R. G.  
 1989 Site Survey in the el-'Umeiri Region. Pp. 98-1188 in *Madaba Plains Project I: The 1984 Season at Tell el-'Umeiri and Vicinity and Subsequent Studies*, ed. L. T. Geraty, L. G. Herr, Ø. S. LaBianca, and R. W. Younker. Berrien Springs, MI: Andrews University/Institute of Archaeology.
- Boraas, R. S., and Geraty, L. T.  
 1976 The Fourth Campaign at Tell Hesban (1974): A Preliminary Report. *Andrews University Seminary Studies* 14: 1-15.
- Briend, J., and Humbert, J-B.  
 1980 *Tell Keisan (1971-76): Une Cité Phénicienne en Galilée*. Orbis Biblicus et Orientalis, Series Archaeologica 1. Fribourg, Suisse: Editions universitaires.
- Brown, R. M.  
 1991 The Ceramics. Pp. 169-279 in *Archaeological Survey of the Kerak Plateau*, ed. J. Miller. Atlanta: Scholars.
- Butler, H. C.  
 1919 *Publications of the Princeton University Archaeological Expedition to Syria in 1904-05 and 1909*, Div. II, Sect. A, Southern Syria. Leiden.

Caubet , A., and Poplin, F.

- 1995 Le travail de l'os, de l'ivoire et de la coquille en Terre Sainte du 7e au 1er millénaires av. J.-C. Pp. 489-495 in *Studies in the History and Archaeology of Jordan V: Art and Technology Throughout the Ages*, ed. K. 'Amr, F. Zayadine, and M. Zaghoul. Amman: Department of Antiquities.

Chapman, R. L.

- 1989 The Three Ages Revisited: A Critical Study of Levantine Usage: Part I: The Critique. *Palestine Exploration Quarterly* 121: 1-111.
- 1990 The Three Ages Revisited: A Critical Study of Levantine Usage: Part II: The Proposal. *Palestine Exploration Quarterly* 122: 1-20.

Clark, D. R.

- 1991 Field B: The Western Defense System. Pp. 53-73 in *Madaba Plains Project 2: The 1987 Season at Tell el-'Umeiri and Vicinity and Subsequent Studies*, ed. L. T. Geraty, L. G. Herr, Ø. S. LaBianca, and R. W. Younker. Berrien Springs, MI: Institute of Archaeology/Andrews University.
- 1997 Field B: The Western Defensive System. Pp. 53-92 in *Madaba Plains Project 3: The 1989 Season at Tell el-'Umeiri and Vicinity and Subsequent Studies*, ed. L. G. Herr, L. T. Geraty, Ø. S. LaBianca, and R. W. Younker. Berrien Springs, MI: Institute of Archaeology/Andrews University.
- 2000 Field B: The Western Defense System. Pp. 59-94 in *Madaba Plains Project – 'Umayri 4: The 1992 Season at Tall al-'Umayri and Subsequent Studies*, eds. L. G. Herr, D. R. Clark, L. T. Geraty, R. W. Younker, and Ø. S. LaBianca. Berrien Springs, MI: Institute of Archaeology/Andrews University.
- 2002 Field B: The Western Defense System. Pp. 48-116 in *Madaba Plains Project – 'Umayri 5: The 1994 Season at Tall al-'Umayri and Subsequent Studies*, eds. L. G. Herr, D. R. Clark, L. T. Geraty, R. W. Younker, and Ø. S. LaBianca. Berrien Springs, MI: Institute of Archaeology/Andrews University.

Clark, V. A.

- 1983 The Iron IIC/Persian Pottery from Rujm al-Henu. *Annual of the Department of Antiquities of Jordan* 27: 143-163.
- 1987 The Desert Survey. Pp. 107-163 in *The Roman Frontier in Central Jordan: Interim Report on the Limes Arabicus Project, 1980-1985*, vol. 1, ed. S. T. Parker. BAR International Series 340. Oxford: British Archaeological Reports.

- Cohen, R.  
 1979 The Iron Age Fortresses in the Central Negev. *Bulletin of the American Schools of Oriental Research* 236: 70.
- Cole, J. A.  
 1989 Random Square Survey in the el-‘Umeiri Region. Pp. 51-97 in *Madaba Plains Project I: The 1984 Season at Tell el-‘Umeiri and Vicinity and Subsequent Studies*, ed. L. T. Geraty, L. G. Herr, Ø. S. LaBianca, and R. W. Younker. Berrien Springs, MI: Andrews University/Institute of Archaeology.
- Coogan, M. D.  
 1975 A Cemetery from the Persian Period at Tell el-Hesi. *Bulletin of the American Schools of Oriental Research* 220: 37-46.
- Cooney, J.  
 1965 Persian Influence in Egyptian Art. *Journal of the American Research Center in Egypt* 4: 39.
- Coulson, W. D. E.  
 1986 *Palestinian Objects at the University of Minnesota*. Malibu: Undena.
- Cross, F. M.  
 1969a An Ostrakon from Heshbon. *Andrews University Seminary Studies* 7: 223-229.  
 1969b Judean Stamps. *Eretz Israel* 9: 20-27.  
 1973a Heshbon Ostrakon II. *Andrews University Seminary Studies* 11: 126-131.  
 1973b Notes on the Ammonite Inscription from Tell Siran. *Bulletin of the American Schools of Oriental Research* 212: 12-15.  
 1975 Ammonite Ostaca from Heshbon Heshbon ostraca IV-VIII. *Andrews University Seminary Studies* 13: 1-20.
- Cross, F. M., and Geraty, L. T.  
 1994 The Ammonite Ostraca from Tell Hesban. Pp. 169-174 in *Hesban After 25 Years*, ed. D. Merling and L. T. Geraty. Berrien Springs, MI: Institute of Archaeology.
- Crowfoot, J. W.  
 1934 An Expedition to Balu‘ah. *Palestine Exploration Quarterly Statement* 66: 76-84.

- Crowfoot, J. W.; Crowfoot, G. M.; and Kenyon, K. M.  
 1957 *The Objects from Samaria*. Samaria-Sebaste 3. London: Palestine Exploration Fund.
- Dabrowski, B.  
 2000 A Preliminary Report on Figurines and Clay Objects. Pp. 215-237 in *Madaba Plains Project – ‘Umayri 4: The 1992 Season at Tall al-‘Umayri and Subsequent Studies*, ed. L. G. Herr, D. R. Clark, L. T. Geraty, R. W. Younker, and Ø. S. LaBianca. Berrien Springs, MI: Institute of Archaeology/Andrews University.
- Dajani, R. W.  
 1964 Iron Age Tombs from Irbed. *Annual of the Department of Antiquities of Jordan* 8-9: 99-101.  
 1966 An Iron Age Tomb from Amman. *Annual of the Department of Antiquities of Jordan* 11: 41-47.
- Dalley, S.  
 1984 The Cuneiform Tablet from Tell Tawilan. *Levant* 16: 19-22.  
 1995 The Cuneiform Tablet. Pp. 67-68, 272-274 in *Excavations at Tawilan in Southern Jordan*, ed. C-M. Bennett and P. Bienkowski. Oxford: University.
- Dandamaev, M. A.  
 1989 *A Political History of the Achaemenid Empire*. Leiden: Brill.
- de Vries, B.  
 1992 Archaeology in Jordan. *American Journal of Archaeology* 96: 503-542.
- Dempsey, D.  
 1993 An Ostrakon from Tell Nimrin. *Bulletin of the American Schools of Oriental Research* 289: 55-58.
- Dever, W. G.; Lance, H. D.; Bullard, R. G.; Cole, D. P.; and Seger, J. D.  
 1974 *Gezer II: Report of the 1967-70 Seasons in Fields I and II*. *Annual of the Hebrew Union College/Nelson Glueck School of Biblical Archaeology*, Vol. 2. Jerusalem: Keter.
- Divito, R. A.  
 1993 The Tell el-Kheleifeh Inscriptions. Pp. 51-63 in *Nelson Glueck's 1938-1940 Excavations at Tell el-Kheleifeh: A Reappraisal*, ed. G. D. Pratico. Atlanta: Scholars.

Dobbs-Allsopp, F. W.

- 1998 Review of *Aramaic Ostraca of the Fourth Century B.C. from Idumaea*, by I. Eph'al and J. Naveh. *Bulletin of the American Schools of Oriental Research* 312: 84-86.

Donner, H., and Röllig, W.

- 1962-4 *Kanaanäische und aramäische Inschriften*, vol. 2. Wiesbaden: O. Harrassowitz.

Dornemann, R. H.

- 1983 *The Archaeology of the Transjordan in the Bronze and Iron Ages*. Milwaukee, WI: Milwaukee Public Museum.
- 1990 Preliminary Comments on the Pottery Traditions at Tell Nimrin, Illustrated from the 1989 Season of Excavations. *Annual of the Department of Antiquities of Jordan* 34: 153-181.

Dothan, M.

- 1955 *Excavations at Afula*. Atiqot 1 (English Series). Jerusalem: Department of Antiquities and Museums.
- 1965 The Fortress at Kadesh-Barnea. *Israel Exploration Journal* 15: 134-151.
- 1971 *Ashdod II-III: The Second and Third Seasons of Excavations 1963, 1965*. Atiqot 9-10 (English Series). Jerusalem: Department of Antiquities and Museums.

Dothan, M., and Freedman, D. N.

- 1967 *Ashdod I: The First Season of Excavations, 1962*. Atiqot 7 (English Series). Jerusalem: Department of Antiquities and Museums.

Dunayevsky, I., and Amiran, R.

- 1958 The Assyrian Open-Court Building and its Palestinian Derivatives. *Bulletin of the American Schools of Oriental Research* 149: 25-32.

Duncan, J. G.

- 1930 *Corpus of Dated Palestinian Pottery*. Publications of the Egyptian Research Account 49. London: British School of Archaeology.

Edelman, D. V., ed.

- 1995 *You Shall Not Abhor an Edomite for He Is Your Brother: Edom and Seir in History and Tradition*. *Archaeology and Biblical Studies* 3. Ed. L. M. White. Atlanta: Scholars.

- Eph'al, I.  
 1982 *The Ancient Arabs: Nomads on the Borders of the Fertile Crescent, 9<sup>th</sup>-5<sup>th</sup> Centuries B.C.* Leiden: Magnes/Brill.
- 1984 *The Ancient Arabs: Nomads on the Borders of the Fertile Crescent 9<sup>th</sup>-5<sup>th</sup> Centuries B.C.* Hebrew University, Jerusalem: Magnes.
- 1988 Syria-Palestine under Achaemenid Rule. Pp. 139-164 in *Cambridge Ancient History* 4 (2<sup>nd</sup> ed.). Ed. J. Boardman, N. G. L. Hammond, D. M. Lewis, and M. Ostwald. Cambridge: Cambridge University Press.
- Eph'al, I., and Naveh, J.  
 1996 *Aramaic Ostraca of the Fourth Century B.C. from Idumaea.* Jerusalem: Magnes.
- Flanagan, J. W., and McCreery, D. W.  
 1990 First Preliminary Report of the 1989 Tell Nimrin Project. *Annual of the Department of Antiquities of Jordan* 34: 131-153.
- Flanagan, J. W.; McCreery, D. W.; and Yassine, K. N.  
 1992 Preliminary Report of the 1990 Excavations at Tell Nimrin. *Annual of the Department of Antiquities of Jordan* 36: 89-111.
- Flemming, G.  
 1987 Bericht ueber drei Sondagen in Umm Qes, Jordanien, im Herbst 1983. *Zeitschrift des Deutschen Palästina-Vereins* 103: 78-100.
- Frank, F.  
 1934 Aus der 'Araba, I. Reiseberichte. *Zeitschrift des Deutschen Palästina-Vereins* 57: 191-280.
- 1994 Tell Nimrin: Preliminary Report on the 1993 Season. *Annual of the Department of Antiquities of Jordan* 38: 205-244.
- Frank, I. M., and Brownstone, D. M.  
 1984 The Great Desert Route and the Persian Royal Road. Pp. 110-127 in *To the Ends of the Earth: The Great Travel and Trade Routes of Human History.* New York: Facts on File.
- Franken, H. J.  
 1969 *Excavations at Tell Deir 'Alla I: A Stratigraphical and Analytical Study of the Early Iron Age Pottery.* Documenta et monumenta Orientis antiquae 16. Leiden: E. J. Brill.

- 1974 *In Search of the Jericho Potters*. North Holland Ceramic Studies in Archaeology 1. Amsterdam: North Holland Publishing Company.
- 1982 A Technological Study of Iron Age I Pottery from Tell Deir 'Alla. Pp. 141-144 in *Studies in the History and Archaeology of Jordan I*, ed. A. Hadidi. Amman: Department of Antiquities.
- Franken, H. J., and Ibrahim, M.  
 1977-8 Two Seasons of Excavations at Tell Deir 'Alla, 1976-1978. *Annual of the Department of Antiquities of Jordan* 22: 57-80.
- 1989 Deir 'Alla (Tell). Pp. 201-205 in *Archaeology of Jordan II, vol. 1. Field Reports Surveys & Sites A-K*, ed. D. Homès-Fredericq and J. B. Hennessy. *Akkadica Supplementum* 7. Leuven: Peeters.
- Geraty, L. T.  
 1975 The 1974 Season of Excavations at Tell Hesban. *Annual of the Department of Antiquities of Jordan* 20: 47-56.
- 1976 The 1976 Season of Excavations at Tell Hesban. *Annual of the Department of Antiquities of Jordan* 21: 41-53.
- Geraty, L. T.; Herr, L. G.; and LaBianca, Ø. S.  
 1988 The Joint Madaba Plains Project: A Preliminary Report of the Second Season at Tell el-'Umeiri and Vicinity (June 18 to August 6, 1987). *Andrews University Seminary Studies* 26/3: 217-252.
- Geraty, L. T.; Herr, L. G.; LaBianca, Ø. S.; and Younker R. W.  
 1989 An Overview of Goals, Methods, and Findings. Pp. 3-19 in *Madaba Plains Project I: The 1984 Season at Tell el-'Umeiri and Vicinity and Subsequent Studies*, ed. L. T. Geraty, L. G. Herr, Ø. S. LaBianca, and R. W. Younker. Berrien Springs, MI: Institute of Archaeology/Andrews University.
- Gitin, S.  
 1979 *An Abstract of a Ceramic Typology of the Late Iron II, Persian and Hellenistic Periods at Tell Gezer*. Cincinnati: Hebrew Union College-Jewish Institute of Religion.
- 1990 *Gezer III A Ceramic Typology of the Late Iron II, Persian and Hellenistic Periods at Tell Gezer*. Jerusalem: Nelson Glueck School of Biblical Archaeology.



Glueck, N.

1934 *Explorations in Eastern Palestine I*. Annual of the American Schools of Oriental Research 14. New Haven: American Schools of Oriental Research.

1935 *Explorations in Eastern Palestine II*. Annual of the American Schools of Oriental Research 15. New Haven: American Schools of Oriental Research.

1939 *Explorations in Eastern Palestine III*. Annual of the American Schools of Oriental Research 18-19. New Haven: American Schools of Oriental Research.

1951 *Exploration in Eastern Palestine IV*. Annual of the American Schools of Oriental Research 25-28. New Haven: American Schools of Oriental Research.

1965 Ezion Geber. *Biblical Archaeologist* 28: 70-87.

1970 *The Other Side of the Jordan*. Cambridge: American Schools of Oriental Research.

1971a Incense Altars. *Eretz Israel* 10: 120-125.

1971b Tell el-Kheleifeh Inscriptions. Pp. 713-717 in *Near Eastern Studies in Honor of William Foxwell Albright*, ed. H. Goedicke. Baltimore, MD: Johns Hopkins.

Gordan, R. L., and Knauf, E. A.

1987 Er-Rumman Survey, 1985. *Annual of the Department of Antiquities of Jordan* 31: 289-298.

Graf, D. F.

1993 The Persian Royal Road System in Syria-Palestine. *Transeuphratene* 6: 149-168

1990 Arabia during the Achaemenid Times. Pp. 131-148 in *Achaemenid History IV, Centre and Periphery: Proceedings of the Groningen 1986 Achaemenid History Workshop*, ed. H. Sancisi-Weerdenburg and A. Kuhrt. Leiden: Nederlands Instituut voor het Nabije Oosten.

Grant, E., and Wright, G. E.

1938 *Ain Shems Excavations IV-V*. Baltimore: Haverford.

- Greene, J. A., and 'Amr, K.  
 1992 Deep Soundings on the Lower Terrace of the Amman Citadel: Final Report. *Annual of the Department of Antiquities of Jordan* 36: 113-144.
- Groot, N.  
 2007 In Search of the Ceramic Traditions of Late Iron Age IIC Pottery Excavated at Tell Deir 'Alla in the Central Jordan Valley. *Leiden Journal of Pottery Studies* 23: 89-108.  
 2009 The Early Persian Period at Tell Deir 'Alla: A Ceramic Perspective. Pp. 167-180 in *Archaeological Studies Leiden University 19: A Timeless Vale. Archaeological and Related Essays on the Jordan Valley in Honour of Gerrit van der Kooij on the Occasion of His Sixty-Fifth Birthday*, ed. E. Kaptijn and L. Petit. Leiden: Leiden University Press.
- Groot, N., and Dik, J.  
 2006 Persian Period Pottery in Transjordan: Towards a Characterization of Ceramic Traditions of an Obscure Period. *Leiden Journal of Pottery Studies* 22: 87-100.  
 2008 Deir 'Alla Phase VII: The Naissance of a Distinct Central Transjordanian Ceramic Tradition. *Leiden Journal of Pottery Studies* 24: 95-114.
- Hadad, H.  
 1984 The Tomb of Umm Udheinah. *Annual of the Department of Antiquities of Jordan* 28: 7-14.
- Hadidi, A.  
 1982 The Archaeology of Jordan: Achievements and Objectives. Pp. 15-21 in *Studies in the History and Archaeology of Jordan I*, ed. A. Hadidi. Amman: Department of Antiquities.  
 1987 An Ammonite Tomb at Amman. *Levant* 19: 101-120.
- Hamilton, R.  
 1935 Excavations at Tell Abu Hawam. *Quarterly of the Department of Antiquities of Palestine* 4: 1-69.
- Hanbury-Tenison, T. W.  
 1984 Wadi Arab Survey 1983. *Annual of the Department of Antiquities of Jordan* 28: 385-423.

Harding, G. L.

- 1944 Two Iron Age Tombs from 'Amman. *Quarterly of the Department of Antiquities of Palestine* 11: 67-74.
- 1948 An Iron-Age tomb at Sahab. *Quarterly of the Department of Antiquities of Palestine* 13: 92-102
- 1950 An Iron-Age Tomb at Meqabelein. *Quarterly of the Department of Antiquities of Palestine* 14: 44-48.
- 1951 Two Iron Age Tombs in Amman. *Annual of the Department of Antiquities of Jordan* 1: 37-40.

Harding, G. L., and Henschel-Simon, E.

- 1944 Two Iron Age Tombs from Amman. *Quarterly of the Department of Antiquities of Palestine* 11: 67-80.

Harding, G. L., and Tufnell, O.

- 1953 The Tomb of Adoni Nur in Amman. *Palestine Exploration Fund Annual* 6: 48-75.

Hart, S.

- 1986 Some Preliminary Thoughts on Settlement in Southern Jordan. *Levant* 18: 51-58.
- 1987a Five Soundings in Southern Jordan. *Levant* 19: 33-47.
- 1987b The Edom Survey Project 1984-85: The Iron Age. Pp. 287-290 in *Studies in the History and Archaeology of Jordan III*, ed. A. Hadidi. Amman: Department of Antiquities.
- 1988 Excavations at Ghrareh, 1986: Preliminary Report. *Levant* 20: 89-99.
- 1989 *The Archaeology of the Land of Edom*. Unpublished doctoral thesis, Macquarie University.
- 1995a Area D at Buseirah and Edomite Chronology. Pp. 241-264 in *Trade, Contact, and the Movement of Peoples in the Eastern Mediterranean: Studies in Honour of J. Basil Hennessy*, ed. S. Bourke and J.-P. Descoedres. Sydney: Mediterranean Archaeology Supplement 3.
- 1995b The Pottery. Pp. 53-66 in *Excavations at Tawilan in Southern Jordan*. British Academy Monographs in Archaeology 8. London: Oxford University.

- Hauptmann, A., and Weisgerber, G.  
 1987 Archaeometallurgical and Mining—Archaeological Investigations in the Area of Feinan, Wadi ‘Arabah (Jordan). *Annual of the Department of Antiquities of Jordan* 31: 419-435.
- Hauptmann, A.; Weisgerber, G.; and Knauf, E. A.  
 1985 Archäometallurgische und bergbauarchäologische Untersuchungen im Gebiet von Fenan, Wadi Arabah (Jordanien). *Der Anschnitt* 37: 163-195.
- Hendrix, R. E.; Drey, P. R.; and Storfjell, J. B.  
 1996 *Ancient Pottery of Transjordan—An Introduction Utilizing Published Whole Forms: Late Neolithic through Late Islamic*. Berrien Springs, MI: Institute of Archaeology/Siegfried H. Horn Archaeological Museum.
- Hennessy, J. B.  
 1970 Excavations at Samaria-Sebaste, 1968. *Levant* 2: 1-21.
- Henschel-Simon, E.  
 1944 Notes on the Pottery of the ‘Amman Tombs. *Quarterly of the Department of Antiquities of Palestine* 11: 75-80.
- Herodotus  
 1971 *Histories*. Trans. A. D. Godley from Greek. London: Loeb Classical Library.
- Herr, L. G.  
 1978 Heshbon 1976: Area D. *Andrews University Seminary Studies* 16: 109-128.
- 1986 A Seventh Century B.C. Tomb Group from Tekoa’. Pp. 265-285 in *The Archaeology of Jordan and Other Studies: Presented to Siegfried H. Horn*, ed. L. T. Geraty and L. G. Herr. Berrien Springs, MI: Andrews University.
- 1989 The Pottery Finds. Pp. 299-354 in *Madaba Plains Project 1: The 1984 Season at Tell el-‘Umeiri and Vicinity and Subsequent Studies*, ed. L. T. Geraty, L. G. Herr, Ø. S. LaBianca, and R. W. Younker. Berrien Springs, MI: Institute of Archaeology/Andrews University.
- 1991a Organization of Excavation and Summary of Results on the Tell. Pp. 8-14 in *Madaba Plains Project 2: The 1987 Season at Tell el-‘Umeiri and Vicinity and Subsequent Studies*, ed. L. T. Geraty, L. G. Herr, Ø. S. LaBianca, and R. W. Younker. Berrien Springs, MI: Institute of Archaeology/Andrews University.

- 1991b Pottery Typology and Chronology. Pp. 232-245 in *Madaba Plains Project 2: The 1987 Season at Tell el-'Umeiri and Vicinity and Subsequent Studies*, ed. L. T. Geraty, L. G. Herr, Ø. S. LaBianca, and R. W. Younker. Berrien Springs, MI: Institute of Archaeology/Andrews University.
- 1992a Epigraphic Finds from Tell el-'Umeiri during the 1989 Season. *Andrews University Seminary Studies* 30/3: 187-200.
- 1992b Two Stamped Jar Impressions of the Persian Province of Ammon from Tell el-'Umeiri. *Annual of the Department of Antiquities of Jordan* 36: 163-166.
- 1993a The Search for Biblical Heshbon. *Biblical Archaeology Review* 19: 36, 37, 68.
- 1993b What Ever Happened to the Ammonites? *Biblical Archaeology Review* 19: 26-35, 68.
- 1995 The Late Iron II-Persian Ceramic Horizon at Tell el-'Umeiri. Pp. 617-619 in *Studies in the History and Archaeology of Jordan V: Art and Technology Throughout the Ages*, ed. K. 'Amr, F. Zayadine, and M. Zaghloul. Amman: Department of Antiquities.
- 1997a Epigraphic Finds from Tall al-'Umayri during the 1989 Season. Pp. 323-330 in *Madaba Plains Project 3: The 1989 Season at Tell el-'Umeiri and Vicinity and Subsequent Studies*, ed. L. G. Herr, L. T. Geraty, Ø. S. LaBianca, and R. W. Younker. Berrien Springs, MI: Institute of Archaeology/ Andrews University.
- 1997b Organization of Excavation and Summary of Results at Tall al-'Umayri. Pp. 7-20 in *Madaba Plains Project 3: The 1989 Season at Tell el-'Umeiri and Vicinity and Subsequent Studies*, ed. L. G. Herr, L. T. Geraty, Ø. S. LaBianca, and R. W. Younker. Berrien Springs, MI: Institute of Archaeology/ Andrews University.
- 1997c The Pottery. Pp. 228-249 in *Madaba Plains Project 3: The 1989 Season at Tell el-'Umeiri and Vicinity and Subsequent Studies*, ed. L. G. Herr, L. T. Geraty, Ø. S. LaBianca, and R. W. Younker. Berrien Springs, MI: Institute of Archaeology/Andrews University.
- 1998 The Palaeography of West Semitic Stamp Seals. Review of *Corpus of West Semitic Stamp Seals*, by N. Avigad, revised and completed by B. Sass. *Bulletin of the American Schools of Oriental Research* 312: 45-77.

- 2000a Excavation and Cumulative Results at Tall al-‘Umayri. Pp. 7-20 in *Madaba Plains Project - ‘Umayri 4: The 1992 Season at Tall al- ‘Umayri and Subsequent Studies*, ed. L. G. Herr, D. R. Clark, L. T. Geraty, R. W. Younker, and Ø. S. LaBianca. Berrien Springs, MI: Institute of Archaeology/Andrews University.
- 2000b The Pottery. Pp. 185-203 in *Madaba Plains Project - ‘Umayri 4: The 1992 Season at Tall al- ‘Umayri and Subsequent Studies*, ed. L. G. Herr, D. R. Clark, L. T. Geraty, R. W. Younker, and Ø. S. LaBianca. Berrien Springs, MI: Institute of Archaeology/Andrews University.
- 2001 The History of the Collared Pithos at Tell el -‘Umeiri, Jordan. Pp. 237-250 in *Studies in the Archaeology of Israel and Neighboring Lands in Memory of Douglas L. Esse*, ed. S. R. Wolff. Chicago: University of Chicago/Oriental Institute.
- 2002a Excavation and Cumulative Results. Pp. 8-22 in *Madaba Plains Project - ‘Umayri 5: The 1994 Season at Tall al- ‘Umayri and Subsequent Studies*, ed. L. G. Herr, D. R. Clark, L. T. Geraty, R. W. Younker, and Ø. S. LaBianca. Berrien Springs, MI: Institute of Archaeology/Andrews University.
- 2002b The Pottery. Pp. 135-155 in *Madaba Plains Project - ‘Umayri 5: The 1994 Season at Tall al- ‘Umayri and Subsequent Studies*, ed. L. G. Herr, D. R. Clark, L. T. Geraty, R. W. Younker, and Ø. S. LaBianca. Berrien Springs, MI: Institute of Archaeology/Andrews University.
- 2006 Black-Burnished Ammonite Bowls from Tall al-‘Umayri and Tall Hisban in Jordan. Pp. 525-540 in *I Will Speak the Riddles of Ancient Times: Archaeological and Historical Studies in Honor of Amihai Mazar on the Occasion of His Sixtieth Birthday*, ed. A.M. Maeir and P. de Miroschedji. Winona Lake: Eisenbrauns.
- Herr, L. G.; Geraty, L. T ; LaBianca, Ø. S.; and Younker, R. W.  
 1991 Madaba Plains Project: The 1989 Excavations at Tell el-‘Umeiri and Vicinity. *Annual of the Department of Antiquities of Jordan* 35: 155-179.
- 1994 Madaba Plains Project: The 1992 Excavations at Tell el-‘Umeiri, Tell Jalul, and Vicinity. *Annual of the Department of Antiquities of Jordan* 38: 147-172.
- Herr, L. G.; Geraty, L. T ; LaBianca, Ø. S.; Younker, R. W; and Clark, D. R.  
 1997 Madaba Plains Project 1996: Excavations at Tall al-‘Umayri, Tall Jalul, and Vicinity. *Annual of the Department of Antiquities of Jordan* 41: 145-167.

- Herr, L. G., and Platt, E. E.  
 2002 The Objects from the 1989 Season. Pp. 358-399 in *Madaba Plains Project - 'Umayri 5: The 1994 Season at Tall al-'Umayri and Subsequent Studies*, ed. L. G. Herr, D. R. Clark, L. T. Geraty, R. W. Younker, and Ø. S. LaBianca. Berrien Springs, MI: Institute of Archaeology/Andrews University.
- Herzfeld, E.  
 1941 *Iran in the Ancient Near East*. Oxford.
- Högemann, P.  
 1985 *Alexander der Grosse und Arabien*. Zetemata 82. München: C. H. Beck.
- Hoglund, K. G.  
 1992 *Achaemenid Imperial Administration in Syria-Palestine and the Missions of Ezra and Nehemiah*. Atlanta: Scholars.
- Holland, T. A.  
 1975 A Typological and Archaeological Study of Human and Animal Representations in the Plastic Art of Palestine during the Iron Age. Volumes 1 and 2. Unpublished Ph.D. dissertation, University of Oxford, England.  
 1977 A Study of Palestinian Iron Age Baked Clay Figurines, with Special Reference to Jerusalem: Cave I. *Levant* 9: 121-155.
- Homès-Fredericq, D.  
 1987 Possible Phoenician Influences in Jordan in the Iron Age. Pp. 89-96 in *Studies in the History and Archaeology of Jordan II*, ed. A. Hadidi. Amman: Department of Antiquities.  
 1995 Stamp and Cylinder Seal Techniques in Jordan. Pp. 469-477 in *Studies in the History and Archaeology of Jordan V: Art and Technology Throughout the Ages*, ed. K. 'Amr, F. Zayadine, and M. Zaghoul. Amman: Department of Antiquities.  
 1996 Influences diverses en Transjordanie à l'époque achéménide. *Transeuphrantène* 11: 63-76.
- Horn, S. H.  
 1967-8 Discoveries at Ancient Heshbon. *Annual of the Department of Antiquities of Jordan* 12 & 13: 51, 52.  
 1972 The 1971 Season of Excavations at Tell Hesban. *Annual of the Department of Antiquities of Jordan* 17: 15-22.

- 1974 The 1973 Season of Excavations at Tell Hesban. *Annual of the Department of Antiquities of Jordan* 19: 151-156.
- Ibach, R.  
 1987 The Regional Survey. *Hesban 5*. Berrien Springs, MI: Institute of Archaeology/Andrews University.
- Ibrahim, M.  
 1972 Archaeological Excavations at Sahab, 1972. *Annual of the Department of Antiquities of Jordan* 17: 23-36.
- 1974 Second Season of Excavations at Sahab, 1973. *Annual of the Department of Antiquities of Jordan* 19: 55-61.
- 1975a Excavations in Jordan in 1975. *Annual of the Department of Antiquities of Jordan* 20: 15-22 (Arabic).
- 1975b Third Season of Excavations at Sahab, 1975 (Preliminary Report). *Annual of the Department of Antiquities of Jordan* 20: 69-82.
- 1989 Sahab. Pp. 516-520 in *Archaeology of Jordan II, vol. 2. Field Reports Sites L-Z*, ed. D. Homès-Fredericq and J. B. Hennessy. *Akkadica Supplementum* 8. Leuven: Peeters.
- Ibrahim, M., and Mittman, S.  
 1986 Al-Mugayyir. *Archiv für Orientforschung* 33: 167-172.
- Ibrahim, M., and van der Kooij, G.  
 1979 Excavations at Tell Deir ‘Alla, Season 1979. *Annual of the Department of Antiquities of Jordan* 23: 41-50.
- 1983 Excavations at Tell Deir ‘Alla, Season 1982. *Annual of the Department of Antiquities of Jordan* 27: 577-585.
- 1986 Excavations at Deir ‘Alla, Season 1984. *Annual of the Department of Antiquities of Jordan* 30: 131-143.
- Ibrahim, M.; Sauer, J.; and Yassine, K.  
 1976 The East Jordan Valley Survey, 1975. *Bulletin of the American Schools of Oriental Research* 222: 41-66.



- Jacobs, L. K.  
 1983 Survey of the South Ridge of Wadi 'Isal, 1981. *Annual of the Department of Antiquities of Jordan* 27: 245-274, figs. 1-15.
- James, F. W.  
 1966 *The Iron Age at Beth Shan: A Study of Levels VI-IV*. Museum Monographs. Philadelphia: University of Pennsylvania Museum.
- Ji, C-H. C.  
 1995 Iron Age I in Central and Northern Transjordan: An Interim Summary of Archaeological Data. *Palestine Exploration Quarterly* 127: 122-140.  
 1997 The East Jordan Valley During the Iron Age I. *Palestine Exploration Quarterly* 129: 19-37.
- Johns, C. N.  
 1932 Excavations at 'Atlit (1930-1): The Southeastern Cemetery. *Quarterly of the Department of Antiquities of Palestine* 2: 41-104.
- Jones, B. G.  
 1985 Interregional Relationships in Jordan: Persistence and Change. Pp. 297-314 in *Studies in the History and Archaeology of Jordan II*, ed. A. Hadidi. Amman: Department of Antiquities.
- Karageorghis, V.  
 1967 *Excavations in the Necropolis of Salamis*, vol. 1. Nikosia: Department of Antiquities.
- Katzenstein, H. J.  
 1979 Tyre in the Early Persian Period (539-486 B.C.E.). *Biblical Archaeologist* 42: 23-36.
- Keel, O.  
 1980 *Das Böcklein in der Milch Seiner Mutter und Verwandtes*. Freiburg-Göttingen: Universitätsvelag.
- Kelm, G. L., and Mazar, A.  
 1985 Tel Batash (Timnah) Excavations: Second Preliminary Report (1981-1983). Pp. 93-120 in *Preliminary Reports of ASOR-Sponsored Excavations 1981-1983*, ed. W. E. Rast. Bulletin of the American Schools of Oriental Research 23. Winona Lake, IN: Eisenbrauns.

Kelso, J. L.

- 1968 *The Excavation of Bethel (1934-1960)*. Annual of the American Schools of Oriental Research 39. Cambridge, MA: American Schools of Oriental Research.

Kelso, J. L., and Thorley, J. P.

- 1943 The Potter's Technique at Tell Beit Mirsim, Particularly in Stratum A. Pp. 86-142 in *The Excavation of Tell Beit Mirsim*, Vol. 3: *The Iron Age*, ed. W. F. Albright. American School of Oriental Research Annual 21-22. New Haven, CT: American Schools of Oriental Research.

Kenna, V. E. G.

- 1973 A L.B. Stamp Seal from Jordan. *Annual of the Department of Antiquities of Jordan* 18: 3-26.

Kenyon, G. L., and Holland, T. A.

- 1982 *Jericho IV*. London: British School of Archaeology.
- 1983 *Jericho V*. London: British School of Archaeology.

Kerestes, T. M.; Lundquist, J. M.; Wood, B. G.; and Yassine, K.

- 1977-8 An Archaeological Survey of Three Reservoir Areas in Northern Jordan, 1978. *Annual of the Department of Antiquities of Jordan* 22: 108-135.

Khalil, L. A.

- 1986 A Bronze Caryatid Censer from Amman. *Levant* 18: 103-110.

Kind, H. D.

- 1966 Antike Kupfergewinnung zwischen Rotem und Totem Meer. *Zeitschrift des Deutschen Palästina-Vereins* 82: 56-73.

King, G.

- 1985 A Survey of the Southern Ghawr, the Wadi 'Araba and Western Trans-Jordan, 1981-2. *Proceedings of the Seminar for Arabian Studies* 15: 41-47.

Knauf, E. A.

- 1984 Zur Keramik von Fenan und Hirbet en-Nahas. *Der Anschnitt* 36: 120-122.

1985a *Ismael: Untersuchungen zur Geschichte Palästinas und Nordarabiens im 1. Jahrtausend v. Chr.* Wiesbaden: Otto Harrassowitz.

1985b Alter und Herkunft der edomitischen Königsliste, Gen 36, 31-39. *Zeitschrift für die alttestamentliche Wissenschaft* 97: 245-253.

- Knauf, E. A., and Lenzen, C. J.  
 1987 Edomite Copper Industry. Pp. 83-88 in *Studies in the History and Archaeology of Jordan III*, ed. A. Hadidi. Amman: Department of Antiquities.
- Kochavi, M.  
 1974 Khirbet Rabud = Debir. *Tel Aviv* 1: 2-33.
- Kurdi, H.  
 1972 A Brief Note on a Bronze Bowl and a Fibula from a Tomb in Ain Ghazal. *Annual of the Department of Antiquities of Jordan* 17: 91-92.
- LaBianca, Ø. S.  
 1989 Intensification of the Food System in Central Transjordan during the Ammonite Period. *Andrews University Seminary Studies* 27/3: 169-178.
- Lamon, R. S., and Shipton, G. M.  
 1939 *Megiddo I: Seasons of 1925-1934*. Oriental Institute Publications 42. Chicago: University of Chicago.
- Landes, G. M.  
 1961 The Material Civilization of the Ammonites. *Biblical Archaeologist* 24: 65-86.
- Lapp, N. L.  
 1974 The Late Persian Pottery. Pp. 30-32 in *Discoveries in the Wâdi ed-Dâliyah. Annual of the American Schools of Orient Research* 41. Cambridge, MA: American Schools of Orient Research.
- Lapp, N. L., ed.  
 1981 *The Third Campaign at Tell el-Fûl: The Excavations of 1964*. Annual of the American Schools of Oriental Research 45. New Haven, CT: American Schools of Oriental Research.
- Lapp, N. L., and Will, E.  
 1989 'Iraq el Amir. Pp. 280-297 in *Archaeology of Jordan II*, ed. D. Homés-Fredericq and J. B. Hennessy. Akkadica Supplementum VII. Leuven: Peeters.
- Lapp, P. W.  
 1962 The 1961 Excavation at 'Araq el-Emir. *Annual of the Department of Antiquities of Jordan* 6 & 7: 80-89.  
 1965 The 1962 Excavation at 'Araq el-Emir. *Annual of the Department of Antiquities of Jordan* 10: 37-42.

1970 The Pottery of Palestine in the Persian Period. Pp. 179-197 in *Archaeologie und Altes Testament: Festschrift für Kurt Galling*, ed. A. Kuschke and E. Kutsch. Tübingen: Mohr.

Lapp, P., and Lapp, N.

1968 Iron II-Hellenistic Pottery Groups. Pp. 54-79 in *The 1957 Excavation at Beth-Zur*, ed. P. Lapp. Annual of the American Schools of Orient Research 38. New Haven, CT: American Schools of Oriental Research.

Lapp, P., and Lapp, N., eds.

1974 *Discoveries in the Wâdi ed-Dâliyeh*. Annual of the American Schools of Orient Research 41. New Haven, CT: American Schools of Oriental Research.

Lawlor, J. I.

1989 Field A. The Ammonite Citadel. Pp. 233-257 in *Madaba Plains Project 1: The 1984 Season at Tell el-'Umeiri and Vicinity and Subsequent Studies*, ed. L. T. Geraty, L. G. Herr, Ø. S. LaBianca, and R. W. Younker. Berrien Springs, MI: Institute of Archaeology/Andrews University.

1991 Field A. The Ammonite Citadel. Pp. 15-52 in *Madaba Plains Project 2: The 1987 Season at Tell el-'Umeiri and Vicinity and Subsequent Studies*, ed. L. T. Geraty, L. G. Herr, Ø. S. LaBianca, and R. W. Younker. Berrien Springs, MI: Institute of Archaeology/Andrews University.

1997 Field A: The Ammonite Citadel. Pp. 21-52 in *Madaba Plains Project 3: The 1989 Season at Tell el-'Umeiri and Vicinity and Subsequent Studies*, ed. L. G. Herr, L. T. Geraty, Ø. S. LaBianca, and R. W. Younker. Berrien Springs, MI: Institute of Archaeology/Andrews University.

2000 Field A: The Administrative Complex. Pp. 21-58 in *Madaba Plains Project - 'Umayri 4: The 1992 Season at Tall al-'Umayri and Subsequent Studies*, ed. L. G. Herr, D. R. Clark, L. T. Geraty, R. W. Younker, and Ø. S. LaBianca. Berrien Springs, MI: Institute of Archaeology/Andrews University.

2002 Field A: The Ammonite Administrative Complex (North). Pp. 23-47 in *Madaba Plains Project - 'Umayri 5: The 1994 Season at Tall al-'Umayri and Subsequent Studies*, ed. L. G. Herr, D. R. Clark, L. T. Geraty, R. W. Younker, and Ø. S. LaBianca. Berrien Springs, MI: Institute of Archaeology/ Andrews University.

- Leach, S., and Rega, E.  
 1996 Interim Report on the Human Skeletal Material Recovered from the 1995 Tell es-Sa'idiyeh Excavations, Areas BB and DD. *Palestine Exploration Quarterly* 128: 131-138.
- Lehmann, G.  
 1998 Trends in the Local Pottery Development of the Late Iron Age and Persian Period in Syria and Lebanon, ca. 700 to 300 B.C. *Bulletin of the American Schools of Oriental Research* 311: 7-37.
- Lemaire, A.  
 1994a Épigraphie et numismatique palestiniennes. Pp. 261-287 in *La Palestine à l'Époque Perse*, ed. E-M. Laperrousaz and A. Lemaire. Paris: Les Éditions du Cerf.  
 1994b Histoire et administration de la Palestine à l'époque perse. Pp. 11-53 in *La Palestine à l'Époque Perse*, ed. E-M. Laperrousaz and A. Lemaire. Paris: Les Éditions du Cerf.  
 1994c Populations et territoires de la Palestine à l'époque perse. *Transeuphratène* 11: 31-74.  
 1995 Recherches sur les ateliers sigillaires jordaniens au Fer II. Pp. 479-488 in *Studies in the History and Archaeology of Jordan V: Art and Technology Throughout the Ages*, ed. K. 'Amr, F. Zayadine, and M. Zaghoul. Amman: Department of Antiquities.
- Lidzbarski, M.  
 1898 *Handbuch der nordsemitischen Epigraphik*. Hildesheim: G. Olms.
- Lindner, M.; Farajat, S.; Knauf, E. A.; and Zeitler, J. P.  
 1990 Es-Sadeh—A Lithic-Early Bronze-Iron II (Edomite)-Nabataean Site in Southern Jordan: Report on the Second Exploratory Campaign, 1988. *Annual of the Department of Antiquities of Jordan* 34: 193-237.
- Lindsay, J.  
 1976 The Babylonian Kings and Edom, 605-550 BC. *Palestine Exploration Quarterly* 108: 23-39.
- Loud, G.  
 1948 *Megiddo II: Seasons of 1935-39*. Oriental Institute Publications 42. Chicago: University of Chicago.

Low, R. D.

- 1991 Field F: The Eastern Shelf. Pp. 170-231 in *Madaba Plains Project 2: The 1987 Season at Tell el-'Umeiri and Vicinity and Subsequent Studies*, ed. L. T. Geraty, L. G. Herr, Ø. S. LaBianca, and R. W. Younker. Berrien Springs, MI: Institute of Archaeology/Andrews University.
- 1997 Field F: The Eastern Shelf. Pp. 188-221 in *Madaba Plains Project 3: The 1989 Season at Tell el-'Umeiri and Vicinity and Subsequent Studies*, ed. L. G. Herr, L. T. Geraty, Ø. S. LaBianca, and R. W. Younker. Berrien Springs, MI: Institute of Archaeology/Andrews University
- 2000 Field F: The Eastern Shelf. Pp. 155-184 in *Madaba Plains Project - 'Umayri 4: The 1992 Season at Tall al-'Umayri and Subsequent Studies*, ed. L. G. Herr, D. R. Clark, L. T. Geraty, R. W. Younker, and Ø. S. LaBianca. Berrien Springs, MI: Institute of Archaeology/Andrews University.

Lugenbeal, E. N., and Sauer, J. A.

- 1972 Seventh-Sixth Century B.C. Pottery from Area B at Heshbon. *Andrews University Seminary Studies* 10: 21-69.

Lux, U.

- 1972 Vorläufiger Bericht über die Ausgrabung unter der Erlöserkirche im Muristan in der Altstadt von Jerusalem in den Jahren 1970 und 1971. *Zeitschrift des Deutschen Palästina-Vereins* 88:185-201.

Mabry, J, and Palumbo, G.

- 1988 The 1987 Wadi el-Yabis Survey. *Annual of the Department of Antiquities of Jordan* 32: 275-305.
- 1989 Wadi Yabis Survey, 1987. Pp. 472-486 in *Archaeology of Jordan* (2.2), ed. D. Homès-Fredericq and J. B. Hennessy. Leiden: Peeters.

Macalister, R. A. S.

- 1912 *The Excavations of Gezer 1902-1905 and 1907-1909, I-III*. London: Committee of the Palestine Exploration Fund.

MacDonald, B.

- 1982 The Wād el-Has Survey 1979 and Previous Archaeological Work in Southern Jordan. *Bulletin of the American Schools of Oriental Research* 245: 35-52.
- 1992 *The Southern Ghors and Northeast 'Arabah Archaeological Survey*. Sheffield Archaeological Monographs 5. Sheffield: University of Sheffield.

MacDonald, B., *et al.*

- 1988 *The Wadi el Hasa Archaeological Survey 1979-1983, West-Central Jordan*. Waterloo, Ontario: Wilfrid Laurier University.

Maisler, B.

- 1951 The Excavations at Tell Qasile: Preliminary Report. *Israel Exploration Journal* 1: 194-218.

Mallowan, M. E. L.

- 1947 Excavations at Brak and Chagar Bazar. *Iraq* 9: 1-259.

Mare, W. H.

- 1978 Heshbon 1976: C.1, 2, 3, 5, 7. *Andrews University Seminary Studies* 16: 51-70.

- 1989 Quweilbeh (Abila). Pp. 91-97 in *Archaeology of Jordan II*, Vol. 1. *Field Reports Surveys & Sites A-K*, ed. D. Homès-Fredericq and J. B. Hennessy. Akkadica Supplementum 8. Leuven: Peeters.

Mare, W.H.; Fuller, M. J.; Hummel, H. D.; Winter, W. W.; Van Elderen, B.; Fuller, N. B.; Maxwell, L. A.; Shoup, J. A.; and Haskins, V. A.

- 1987 The 1986 Season at Abila of the Decapolis. *Annual of the Department of Antiquities of Jordan* 31: 205-219.

Matson, F. R.

- 1971 A Study of Temperatures Used in Firing Ancient Mesopotamian Pottery. Pp. 65-79 in *Science and Archaeology*. Cambridge, MA: MIT.

Maxwell-Hyslop, R.

- 1984 The Gold Jewellery. *Levant* 16: 22, 23.

Mazar, B., and Dunayevsky, I.

- 1064 En-Gedi: Third Season of Excavations. *Israel Exploration Journal* 14: 121-130.

Mazar, B.; Dothan, T.; and Dunayevsky, I.

- 1966 En-Gedi: The First and Second Seasons of Excavations, 1961-1962. *Atiqot* 5: 1-100.

McCown, C. C.

- 1947 *Tell en-Nasbeh I: Archaeological and Historical Results*. Berkeley: Palestine Institute of Pacific School of Religion.

McGovern, P.

- 1980 Explorations in the Umm ad-Dananir Region of the Baq'ah Valley 1977-1978. *Annual of the Department of Antiquities of Jordan* 24: 55-67, 255-261.
- 1981 The Baq'ah Valley Project. *Annual of the Department of Antiquities of Jordan* 25: 356, 357.
- 1983a Baq'ah Valley Project Symposium. *Annual of the Department of Antiquities of Jordan* 27: 641-647.
- 1983b Test Soundings of Archaeological and Resistivity Survey Results at Rujm el-Henu. *Annual of the Department of Antiquities of Jordan* 27: 105-137.
- 1985 Environmental Constraints for Human Settlement in the Baq'ah Valley. Pp. 141-148 in *Studies in the History and Archaeology of Jordan II*, ed. A. Hadidi. Amman: Department of Antiquities.
- 1989a The Baq'ah Valley Project 1987: Khirbet Umm ad-Dananir and al-Qesir. *Annual of the Department of Antiquities of Jordan* 33: 123-136.
- 1989b Baq'ah Valley Survey. Pp. 25-44 in *Archaeology of Jordan II*, Vol. 1: *Field Reports Surveys & Sites A-K*, ed. D. Homès-Fredericq and J. B. Hennessy. *Akkadica Supplementum* 7. Leuven: Peeters.
- 1995 Technological Innovation and Artistic Achievement in the Late Bronze and Iron Ages of Central Transjordan. Pp. 29-37 in *Studies in the History and Archaeology of Jordan V: Art and Technology Throughout the Ages*, ed. K. 'Amr, F. Zayadine, and M. Zaghloul. Amman: Department of Antiquities.

Merling, D.

- 1994 The "Pools of Heshbon": As Discovered by the Heshbon Expedition. Pp. 211-223 in *Heshbon After 25 Years*, ed. D. Merling and L. T. Geraty. Berrien Springs, MI: Institute of Archaeology.

Miller, J. M. (ed.)

- 1991 *Archaeological Survey of the Kerak Plateau*. Atlanta: Scholars.

Mittman, S.

- 1970 *Beiträge zur Siedlungs—und Territorial—geschichte des Nordlichen Ostjordanlandes*. Wiesbaden: Harrassowitz.

Moorey, P. R. S.

- 1973 Some Syro-Phoenician Bronze Caryatid Stands. *Levant* 5:83-99.



- 1980 *Cemeteries of the First Millennium B.C. at Deve Hüyük*. Bar International Series 82. England: Oxford.
- Musil, A.  
1907 *Arabia Petraea II. Edom. Topographischer Reisebericht. 1. Teil*. Wien: Alfred Hölder.
- Naster, P.  
1986 Numismatique. Monnaies phéniciennes et puniques. Pp. 271-278 in *Les Phéniciens et le monde méditerranéen/De Feniciërs en de mediterrane wereld*, ed. E. Gubel. Bruxelles-Brussel.
- Naveh, J.  
1962 The Excavations at Mesad Hashavyahu: Preliminary Report. *Israel Exploration Journal* 12: 89-113.  
  
1970 *The Development of the Aramaic Script*. Jerusalem: Ahva.
- Noth, M.  
1928 *Die israelitischen Personennamen*. Stuttgart: Kohlhammer.
- Oakeshott, M. F.  
1978 *A Study of the Iron Age II Pottery of East Jordan with Special Reference to Unpublished Material from Edom*. Unpublished Ph.D. thesis, University of London.  
  
1983 The Edomite Pottery. Pp. 53-63 in *Midian, Moab, and Edom: The History and Archaeology of Late Bronze and Iron Age Jordan and North-West Arabia*, ed. J. F. A. Sawyer and D. J. A. *Journal for the Study of the Old Testament Supplement Series* 24. Clines. Sheffield: Journal for the Study of the Old Testament.
- Oates, J.  
1959 Late Assyrian Pottery from Fort Shalmaneser. *Iraq* 21: 130-146.
- Olavarri, E.  
1965 Sondages à 'Arô'er sur l'Arnon. *Revue Biblique* 72: 77-94.
- Olavarri-Goicoechea, E.  
1985 *El Palacio Omeya de Amman 2: La Arqueologia*. Valencia: Institucion San Jeronimo.

- Ottosson, M.  
 1993 The Iron Age of Northern Jordan. Pp. 90-103 in *History and Traditions of Early Israel: Studies Presented to Edward Nielsen*, ed. A. Lemaire and B. Otzen. Leiden: E. J. Brill.
- Parker, S. T.  
 1976 Archaeological Survey of the *Limes Arabicus*: A Preliminary Report. *Annual of the Department of Antiquities of Jordan* 21: 19-31.  
 1986 *Romans and Saracens: A History of the Arabian Frontier*. ASOR Dissertation Series 6. Winona Lake, IN: Eisenbrauns.
- Parr, P.  
 1982 Contacts Between North West Arabia and Jordan in the Late Bronze and Iron Ages. Pp. 127-133 in *Studies in the History and Archaeology of Jordan I*, ed. A. Hadidi. Amman: Department of Antiquities.
- Petrie, W. M. F.  
 1928 *Gerar*. Publications of the British School of Archaeology in Egypt 43. London: British School of Archaeology in Egypt.  
 1930 *Beth Pelet (tell Fara) I*. Publications of the Egyptian Research Account 48. London: British School of Archaeology in Egypt.
- Pope, A. U.  
 1960 *A Survey of Persian Art XIV*. London: Oxford University Press.
- Porada, E.  
 1989 Two Cylinder Seals from 'Umeiri, Nos. 49 and 363. Pp. 381-384 in *Madaba Plains Project I: The 1984 Season at Tell el-'Umeiri and Vicinity and Subsequent Studies*, ed. L. T. Geraty, L. G. Herr, Ø. S. LaBianca, and R. W. Younger. Berrien Springs, MI: Andrews University.
- Porath, J.  
 1974 A Fortress of the Persian Period. *Atiqot* 7 (Hebrew Series): 43-55.
- Prag, K.  
 1989 Preliminary Report on the Excavations at Tell Iktanu, Jordan, 1987. *Levant* 21: 33-45.
- Pratico, G. D.  
 1985 Nelson Glueck's 1938-1940 Excavations at Tell el-Kheleifeh: A Reappraisal. *Bulletin of the American Schools of Oriental Research* 259: 1-32.

- 1993 *Nelson Glueck's 1938-1940 Excavations at Tell el-Kheleifeh: A Reappraisal*, ed. L. G. Herr. American Schools of Oriental Research Archaeological Reports 03. Atlanta: Scholars.
- Prausnitz, M. W.; Avi-Yonah, M.; and Barag, D.  
 1967 *Excavations at Shavei Zion: The Early Christian Church*. Rome: Centro per le Antichita e la Storia dell'arte del Vicino Oriente.
- Pritchard, J. B.  
 1954 *Ancient Near Eastern Texts Relating to the Old Testament*. Princeton: University Press.  
 1961 *The Water System at Gibeon*. Museum Monographs. Philadelphia: University of Pennsylvania Museum.  
 1964 *Winery, Defences, and Soundings at Gibeon*. Philadelphia: University of Pennsylvania Museum.  
 1972 An Incense Burner from Tell es-Sa'idiyeh, Jordan Valley. Pp. 9-17 in *Studies on the Ancient Palestinian World*, ed. J. W. Weavers and D. B. Redford. Toronto: University of Toronto.  
 1985 *Tell es-Sa'idiyeh: Excavations on the Tell, 1964-1966. University Museum Monograph 60*. Philadelphia: University Museum/University of Pennsylvania.
- Rast, W.  
 1978 *Taanach I: Studies in the Iron Age Pottery*. Ed. A. E. Glock. Excavation Reports. Philadelphia: American Schools of Oriental Research.
- Ray, P.  
 2001 *Hesban and Vicinity in the Iron Age. Hesban 6*. Berrien Springs, MI: Andrews University Press.  
 2006 *Connectivity: Transjordan During the Persian Period*. Pp. 75-92 in *Connectivity in Antiquity: Globalization as a Long-Term Historical Process*, ed. Ø. S. LaBianca and S. A. Scham. London: Equinox Publishers.
- Reed, W. L.  
 1972 The Archaeological History of Elealeh in Moab. Pp. 18-28 in *Studies on the Ancient Palestinian World Presented to Professor F. V. Winnett*. Toronto Semitic Texts and Studies 2, ed. J. W. Weavers and D. B. Redford. Toronto: University of Toronto.

- Reisner, G. A.; Fisher, C. S.; and Lyon, D. G.  
 1924 *Harvard Excavations at Samaria I-II*. Cambridge: Harvard University.
- Reuther, O.  
 1968 *Die Innenstadt von Babylon (Merkes)*. Wissenschaftliche Veröffentlichungen der deutschen Orientgesellschaft 47. Berlin.
- Sapin, J.  
 1996 Reflexions sur des strategies et des techniques d'adaptation dans la Transjordanie du 1<sup>er</sup> millénaire. *Transeuphratène* 11: 45-61.
- Sauer, J. A.  
 1973 *Heshbon Pottery 1971: A Preliminary Report on the Pottery from the 1971 Excavations at Tell Hesban*. Andrews University Monographs VII. Berrien Springs, MI: Andrews University.  
 1975 Area B and Square D.4. *Andrews University Seminary Studies* 13.1-2: 133-167.  
 1986 Transjordan in the Bronze and Iron Ages: A Critique of Glueck's Synthesis. *Bulletin of the American Schools of Oriental Research* 263: 1-26.  
 1994 The Pottery at Hesban and Its Relationships to the History of Jordan: An Interim Hesban Pottery Report, 1993. Pp. 225-281 in *Hesban After 25 Years*, ed. D. Merling and L. T. Geraty. Berrien Springs, MI: Institute of Archaeology.
- Schmidt, E. F.  
 1957 *Persepolis II: Contents of the Treasury and Other Discoveries*. Oriental Institute Publications LXVIII. Chicago: University of Chicago Press.
- Sellers, O., et al.  
 1968 *The 1957 Excavation at Beth-zur*. Annual of the American Schools of Oriental Research 38. Cambridge, MA: American Schools of Oriental Research.
- Shea, M. O.  
 1983 The Small Cuboid Incense-burners of the Ancient Near East. *Levant* 15: 76-109.
- Shipton, G. M.  
 1973 Notes on the Megiddo Pottery of Strata VI-XX. *Studies in Ancient Oriental Civilization* 17. Chicago: University of Chicago Press.

- Sinclair, L. A.
- 1960 *An Archaeological Study of Gibeah (Tell el-Fûl)*. Annual of the American Schools of Oriental Research 34-35. New Haven, CT: American Schools of Oriental Research.
  - 1968 Bethel Pottery of the Sixth Century B.C. Pp. 70-76 in *The Excavation of Bethel (1934-1960)*. Annual of the American Schools of Oriental Research 39. Cambridge: American Schools of Oriental Research.
- Steiner, M. L., and Jacobs, L.
- 2008 The Iron Age Pottery of al-Lehun, Jordan: Fabrics and Technology. *Leiden Journal of Pottery Studies* 24: 133-140.
- Stern, E.
- 1978 *The Excavations of Tel Mevorakh, I. The Hellenistic, Persian, and Israelite Strata*. Qedem 9. Jerusalem: Hebrew University.
  - 1980 Achaemenian Tombs from Shechem. *Levant* 12: 90-111.
  - 1982 *Material Culture of the Land of the Bible in the Persian Period, 538-332 B.C.* Jerusalem: Israel Exploration Society.
- Stern, E., and Magen, Y.
- 1984 A Pottery Group of the Persian Period from Qadum in Samaria. *Bulletin of the American Schools of Oriental Research* 253: 9-27.
- Steuernagel, D. C.
- 1926 Der 'Adschl\_n. Nach den Aufzeichnungen von Dr. G. Schumacher. *Zeitschrift des Deutschen Palästina-Vereins* 49: 1-127.
- Strange, J.
- 1997 Tell el Fukhar 1990-1991: Preliminary Account. Pp. 399-406 in *Studies in the History and Archaeology of Jordan* 6, ed. A. Hadidi. Amman: Department of Antiquities.
- Stronach, D.
- 1959 The Development of the Fibula in the Near East. *Iraq* 21: 181-206.
- Taleb, M. A.
- 1985 The Seal of Pity bn m'as the mazkir. *Zeitschrift des Deutschen Palästina-Vereins* 101: 21-29.

- Thompson, H. O.
- 1971 Iron Age Cosmetic Palettes. *Annual of the Department of Antiquities of Jordan* 16: 61-70.
  - 1972 The 1972 Excavation of Khirbet el-Hajjar. *Annual of the Department of Antiquities of Jordan* 17: 47-72.
  - 1973 Rujm Al-Malfuf South. *Annual of the Department of Antiquities of Jordan* 18: 47-50.
  - 1977 The Ammonite Remains at Khirbet el-Hajjar. *Bulletin of the American Schools of Oriental Research* 227: 27-34.
- Thompson, R. C., and Mallowan, M. E. L.
- 1932 The British Museum Excavations at Nineveh, 1931-1932. *Annals of Archaeology and Anthropology* 20: 71-186.
- Toombs, L. E., and Wright, G. E.
- 1963 The Fourth Campaign at Balâtah (Shechem). *Bulletin of the American Schools of Oriental Research* 160: 1-60.
- Tubb, J. N.
- 1989 Sa'idiyeh (Tell el). Pp. 521-542 in *Archaeology of Jordan II*, Vol. 2: *Field Reports Sites L-Z*, ed. D. Homès-Fredericq and J. B. Hennessy. *Akkadica Supplementum* 8. Leuven: Peeters.
  - 1990 Preliminary Report on the Fourth Season of Excavations at Tell es-Sa'idiyeh in the Jordan Valley. *Levant* 22: 21-42.
- Tubb, J. N., and Dorrell, P. G.
- 1991 Tell es-Sa'idiyeh: Interim Report on the Fifth (1990) Season of Excavations. *Levant* 23: 67-86.
  - 1994 Tell es-Sa'idiyeh 1993: Interim Report on the Seventh Season of Excavations. *Palestine Exploration Quarterly* 126: 52-67.
- Tubb, J. N., and Rowan, D.
- 1988 Tell es-Sa'idiyeh: Preliminary Report on the First Three Seasons of Renewed Excavations. *Levant* 20: 23-88.
- Tubb, J. N.; Dorrell, P. G.; and Cobbing, F. J.
- 1996 Interim Report on the Eighth (1995) Season of Excavations at Tell es-Sa'idiyeh. *Palestine Exploration Quarterly* 128: 16-40.

- Tufnell, O., et al.  
 1953 *Lachish III, The Iron Age*. London: Oxford University.
- Tushingham, A. D.  
 1972 *The Excavations at Dibon (Dh\_bân) in Moab: The Third Campaign 1952-53*. Annual of the American Schools of Oriental Research 40. New Haven, CT: American Schools of Oriental Research.
- van der Kooij, G.  
 1987a The Identity of Trans-Jordanian Alphabetic Writing in the Iron Age. Pp. 107-121 in *Studies in the History and Archaeology of Jordan III*, ed. A. Hadidi. Amman: Department of Antiquities.  
 1987b Tell Deir ‘Alla (East Jordan Valley) During the Achaemenid Period: Some Aspects of the Culture. Pp. 97-102 in *Achaemenid History I: Sources, Structures, and Synthesis*, ed. H. Sancisi-Weerdenburg. Leiden: Nederlands Instituut voor het Nabije Oosten.
- van der Kooij, G., and Ibrahim, M. M., eds.  
 1989 *Picking up the Threads . . . A Continuing Review of Excavations at Deir Alla, Jordan*. Leiden: University of Leiden Archaeological Centre.
- Van Wyk, K.  
 1993 *Squatters in Moab: A Study in Iconography, History, Epigraphy, Orthography, Ethnography, Religion, and Linguistics in the ANE*. Berrien Center, MI: Louis Hester.
- Van Zyl, A. H.  
 1960 *The Moabites*. Pretoria oriental series 3. Leiden: E. J. Brill.
- Vilders, M.  
 1995 Some Technological Features of Tall as-Sa‘idiyya Cooking Pots. Pp. 597-601 in *Studies in the History and Archaeology of Jordan V: Art and Technology Throughout the Ages*, ed. K. ‘Amr, F. Zayadine, and M. Zaghoul. Amman: Department of Antiquities.
- Von-Oppenheim, M.  
 1934 *Tell Halaf*. Berlin: London: G. P. Putnam’s Sons.
- Vriezen, K. J. H.  
 1975 Hirbet Kefire—eine Oberflächenuntersuchung. *Zeitschrift des Deutschen Palästina-Vereins* 91: 135-158.

Waldbaum, J.

- 1991 Note: Two Attic Sherds. P. 243 in *Madaba Plains Project 2: The 1987 Season at Tell el-'Umeiri and Vicinity and Subsequent Studies*, ed. L. T. Geraty, L. G. Herr, Ø. S. LaBianca, and R. W. Younker. Berrien Springs, MI: Institute of Archaeology/Andrews University.

Wampler, J. C.

- 1940 Triangular Impressed Design in Palestinian Pottery. *Bulletin of the American Schools of Oriental Research* 80: 25-43.
- 1941 Three Cistern Groups from Tell en-Nasbeh. *Bulletin of the American Schools of Oriental Research* 82: 25-43.
- 1947 *Tell en-Nasbeh I and II*. Berkeley: Palestine Institute of Pacific School of Religion and American Schools of Oriental Research.

Weinberg, S. S.

- 1971 Tel Anafa: The Hellenistic Town. *Israel Exploration Journal* 21: 86-109.

Weippert, M.

- 1982a Remarks on the History of Settlement in Southern Jordan during the Early Iron Age. Pp. 153-162 in *Studies in the History and Archaeology of Jordan I*, ed. A. Hadidi. Amman: Department of Antiquities.
- 1982b Edom und Israel. Pp. 291-299 in *Theologische Realenzyklopädie*. Berlin: W. de Gruyter.

Wenning, R.

- 1981 Griechische Importe in Palästina aus der Zeit vor Alexander d. Gr. Vorbericht ber ein Forschungsprojekt. *Boreas* 4: 29-46.

Wimmer, D. H.

- 1987a The Excavations at Tell Safut. Pp. 279-282 in *Studies in the History and Archaeology of Jordan III*, ed. A. Hadidi. Amman: Department of Antiquities.
- 1987b Tell Safut Excavations, 1982-1985: Preliminary Report. *Annual of the Department of Antiquities of Jordan* 31: 157-174.

Winnett, F. V., and Reed, W. L.

- 1964 *The Excavations at Dibon (Dhiban) in Moab*. Ed. G. W. Van Beek. *Annual of the American Schools of Oriental Research* 36-37. New Haven, CT: American Schools of Oriental Research.



- Worscheck, U.  
 1989 Preliminary Report on the Second Campaign at the Ancient Site of el-Balu' in 1987. *Annual of the Department of Antiquities of Jordan* 33: 111-121.
- Wright, G. E.  
 1965 *Shechem: The Biography of a Biblical City*. New York: McGraw-Hill.
- Wright, K.; Schick, R.; and Brown, R.  
 1989 Report on a Preliminary Survey of the Wadi Shu'eib. *Annual of the Department of Antiquities of Jordan* 33: 345-350.
- Yadin, Y.; Aharoni, Y.; Amiran, R.; Dothan, T.; Dunayevsky, I.; and Perrot, J.  
 1958 *Hazor I: An Account of the First Season of Excavations, 1955*. Jerusalem: Magnes.  
 1960 *Hazor II: An Account of the Second Season of Excavations, 1956*. Jerusalem: Magnes.  
 1961 *Hazor III-IV: An Account of the Third and Fourth Seasons of Excavations, 1957-1958. The Plates*. Jerusalem: Magnes.
- Yamauchi, E. M.  
 1996 *Persia and the Bible*. Grand Rapids, MI: Baker Books.
- Yassine, K.  
 1974 Domestic Architecture in the Second Millenium in Palestine. Ph.D. dissertation, University of Chicago.  
 1982 Ammonite Seals from Tell el-Mazar. Pp. 189-194 in *Studies in the History and Archaeology of Jordan I*, ed. A. Hadidi. Amman: Department of Antiquities.  
 1983 Tell El Mazar, Field I. Preliminary Report of Area G, H, L, and M: The Summit. *Annual of the Department of Antiquities of Jordan* 27: 495-513.  
 1984 *Tell el-Mazar Cemetery A*. Amman: University of Jordan.  
 1988a Ammonite Fortresses, Date, and Function. Pp. 11-31 in *Archaeology of Jordan: Essays and Reports*, ed. K. Yassine. Amman: Department of Archaeology, University of Jordan.

- 1988b Ammonite Seals from Tell el-Mazar. Pp. 143-155 in *Archaeology of Jordan: Essays and Reports*, ed. K. Yassine. Amman: Department of Archaeology, University of Jordan.
- 1988c Tell El Mazar Field I: Preliminary Report of Areas G, H, L, and M. Pp. 73-113 in *Archaeology of Jordan: Essays and Reports*, ed. K. Yassine. Amman: Department of Archaeology, University of Jordan.
- 1989 Mazar (Tell el). Pp. 381-384 in *Archaeology of Jordan II, Vol. 2: Field Reports Sites L-Z*, eds. D. Homès-Fredericq and J. B. Hennessy. Akkadica Supplementum 8. Leuven: Peeters.

Yassine, K., and Sauer, J.

- 1988 Archaeology of Jordan in Perspective. Pp. 259-273 in *Archaeology of Jordan: Essays and Reports*, ed. K. Yassine. Amman: Department of Archaeology, University of Jordan.

Yassine, K., and Teixidor, J.

- 1986 Ammonite and Aramaic Inscriptions from Tell el-Mazar. *Bulletin of the American Schools of Oriental Research* 264: 45-50.
- 1988 Ammonite and Aramaic Inscriptions from Tell el-Mazar. Pp. 137-142 in *Archaeology of Jordan: Essays and Reports*, ed. K. Yassine. Amman: Department of Archaeology, University of Jordan.

Yassine, K.; Sauer, J.; and Ibrahim, M.

- 1988 The East Jordan Valley Survey, 1975 and 1976. Pp. 159-207 in *Archaeology of Jordan: Essays and Reports*, ed. K. Yassine. Amman: Department of Archaeology, University of Jordan.

Yunker, R. W.

- 1989 "Towers" in the Region Surrounding Tell el-'Umeiri. Pp. 195-197 in *Madaba Plains Project 1: The 1984 Season at Tell el-'Umeiri and Vicinity and Subsequent Studies*, ed L. T. Geraty, L. G. Herr, Ø. S. LaBianca, and R. W. Yunker. Berrien Springs, MI: Andrews University/Institute of Archaeology.
- 1991 The Judgment Survey. Pp. 269-334 in *Madaba Plains Project 2: The 1987 Season at Tell el-'Umeiri and Vicinity and Subsequent Studies*, ed L. G. Herr, L. T. Geraty, Ø. S. LaBianca, and R. W. Yunker. Berrien Springs, MI: Andrews University/Institute of Archaeology.
- 2009 The Persian Period at Tall Jalul, Jordan. *Eretz Israel* 29: 258-266.

- Yunker, R. W.; Geraty, L. T.; Herr, L. G.; and LaBianca, Ø. S.
- 1990 The Joint Madaba Plains Project: A Preliminary Report of the 1989 Season, including the Regional Survey and Excavations at El-Dreijat, Tell Jawa, and Tell el-‘Umeiri (June 19 to August 8, 1989). *Andrews University Seminary Studies* 28/1: 5-52.
- 1993 The Joint Madaba Plains Project: A Preliminary Report of the 1992 Season, Including the Regional Survey and Excavations at Tell Jalul and Tell El-‘Umeiri (June 16 to July 31, 1992). *Andrews University Seminary Studies* 31: 205-238.
- Yunker, R. W.; Geraty, L. T.; LaBianca, Ø. S.; Herr, L. G.; and Clark, D.
- 1996 Preliminary Report of the 1994 Season of the Madaba Plains Project: Regional Survey, Tall al-‘Umayri, and Tall Jalul Excavations (June 15 to July 30, 1994). *Andrews University Seminary Studies* 34/1: 65-92.
- Zayadine, F.
- 1973 Recent Excavations on the Citadel of Amman. *Annual of the Department of Antiquities of Jordan* 15: 17-35.
- 1985 Une tombe du Fer II à Umm Udheinah. *Syria* 62: 155-156.
- 1986 L'époque perse-achéménide. Pp. 142-151 in *La Voie Royale: 9000 Ans d'Art au Royaume de Jordanie*. Paris: Association Française d'Action Artistique.
- 1995 Cosmetic Techniques: A Historical and Botanical Approach. Pp. 67-75 in *Studies in the History and Archaeology of Jordan V: Art and Technology Throughout the Ages*, ed. K. ‘Amr, F. Zayadine, and M. Zaghoul. Amman: Department of Antiquities.
- Zayadine, F., and Thompson, H. O.
- 1973 The Ammonite Inscription from Tell Siran. *Berytus* 22: 115-140.
- Zayadine, F.; Najjar, M.; and Greene, J. A.
- 1987 Recent Excavations on the Citadel of Amman (Lower Terrace): A Preliminary Report. *Annual of the Department of Antiquities of Jordan* 31: 299-311.