

9-2015

Vanadium Oxide Thin-Film Variable Resistor-Based RF Switches

KuanChang Pan
University of Dayton

Weisong Wang
University of Dayton, wwang4@udayton.edu

Eunsung Shin
University of Dayton, eshin1@udayton.edu

Kelvin Freeman
University of Dayton

Guru Subramanyam
University of Dayton, gsubramanyam1@udayton.edu

Follow this and additional works at: https://ecommons.udayton.edu/ece_fac_pub

 Part of the [Computer Engineering Commons](#), [Electrical and Electronics Commons](#), [Electromagnetics and Photonics Commons](#), [Optics Commons](#), [Other Electrical and Computer Engineering Commons](#), and the [Systems and Communications Commons](#)

eCommons Citation

Pan, KuanChang; Wang, Weisong; Shin, Eunsung; Freeman, Kelvin; and Subramanyam, Guru, "Vanadium Oxide Thin-Film Variable Resistor-Based RF Switches" (2015). *Electrical and Computer Engineering Faculty Publications*. 99.
https://ecommons.udayton.edu/ece_fac_pub/99

This Article is brought to you for free and open access by the Department of Electrical and Computer Engineering at eCommons. It has been accepted for inclusion in Electrical and Computer Engineering Faculty Publications by an authorized administrator of eCommons. For more information, please contact frice1@udayton.edu, mschlangen1@udayton.edu.

Vanadium Oxide Thin Film Variable Resistor Based RF switches

KuanChang Pan, *Student Member, IEEE*, Weisong Wang, *Member, IEEE*, Eunsung Shin, Kelvin Freeman, and Guru Subramanyam, *Senior Member, IEEE*

Abstract—Vanadium dioxide (VO₂) is a unique phase change material (PCM) that possesses a metal to insulator transition. Pristine VO₂ has a negative temperature coefficient of resistance and undergoes an insulator to metal phase change at a transition temperature of 68°C. Such property makes the vanadium dioxide thin film based variable resistor (varistor) a good candidate in reconfigurable electronics, to be integrated with different RF devices like inductors, varactors, and antennas. Series single-pole single throw (SPST) switches with integrated VO₂ thin films were designed, fabricated and tested. The overall size of the device is 380 μm x 600 μm. The SPST switches were fabricated on a sapphire substrate with integrated heating coil to control VO₂ phase change. During the test, when VO₂ thin film changed from insulator at room temperature to metallic state (low resistive phase) at 80°C, the insertion loss of the SPST switch was below 3 dB at 10 GHz. And, the isolation of the SPST improved to better than 30 dB when the temperature dropped to 20°C. These tunable characteristics of the RF switch provide evidence for VO₂ as a useful PCM for broad range of applications in reconfigurable electronics.

Index Terms—Vanadium dioxide (VO₂), thin film, varistor, metal-insulator transition, switch, coplanar waveguide (CPW).

I. INTRODUCTION

Vanadium oxides attract researchers' attention recently due to the unique property in metal-insulator transition (MIT) [1, 2] at various temperatures. Since the discovery of MIT in 1959 by Morin [1], the research focus was mainly on VO_x or combined multiphase vanadium oxides. This was due to the limitations in manufacturing technologies to obtain high quality, single phase vanadium oxide thin films. The stable forms of vanadium oxides for microelectronic devices are VO, V₂O₃, VO₂, V₂O₅ and VO₃ [3-10]. Research on electrochromic and thermo-chromic effects have been studied on VO_x for electro-optical device applications, initiated by Honeywell in 1990s [11]. Since then it had become one of the promising materials in current uncooled IR imager manufacturing. Advancement in thin film deposition such as pulsed laser deposition (PLD) during recent decades provided necessary technologies to lay down single phase vanadium oxide such as

VO₂. VO₂ has a constant and stable insulator to metal transition temperature at 68°C and superior resistivity ratio between metallic and insulator phases compared to other forms of vanadium oxides [12-18]. With pure VO₂, such large amplitude change in resistivity provides a good opportunity for researchers in reconfigurable electronics area with simplified device structures. Recently, tunable devices have attracted a lot of attention in electronics in order to build a more versatile systems with fewer devices [19, 20]. Specifically in modern communication systems, the flexibility of reconfigurable RF and microwave electronics will support multiple modes over a wide bandwidth and a variety of communication protocols.

Typical reconfigurable devices include variable capacitors (varactors), variable inductors and variable resistors (varistors). These adaptive devices could allow the engineers to dynamically match the impedance of power amplifiers (PAs), tunable filters, and phase control circuits.

The VO₂ property we used in this article will focus on varistor RF/microwave applications. Currently the resistance change in terms of the MIT has been researched [21-23]. The resistance of VO₂ has been measured in different kinds of experiments. First, the resistance of VO₂ was measured at hydrostatic pressures up to 2GPa and room temperature by using electric-field-induced resistance switching (EIRS) of VO₂ planar-type junctions [24]. Second, the VO₂ was fabricated in number of parallel strip patterns in the varistor, and the resistance of VO₂ thin film has been measured [25]. Third, the resistance of the VO₂ was measured by VO₂ thin film based RF shunt resonator, and the VO₂ thin film was deposited as shunt resistance in this device [26].

In this paper, the study of achieving high quality single phase VO₂ thin film using the pulsed laser deposition technique is presented. SPST device has been used as an example to demonstrate the effect of VO₂ thin film in RF device performance.

II. DESIGN OF SERIES SINGLE-POLE SINGLE THROW (SPST) SWITCH DEVICE

A series single-pole single throw (SPST) switch is designed with the VO₂ thin film. The series SPST switch is implemented in a coplanar waveguide (CPW) transmission line configuration. A coupled line structure is formed in the middle of the signal line of the CPW, with the VO₂ thin-film designed to bridge between input and output signal lines. At room temperature, the VO₂ film acts like an insulator making the

K.C. Pan, W. Wang, K. Freeman, and G. Subramanyam are with Electrical and Computer Engineering Department, University of Dayton, Dayton, OH 45469 USA (email: wwang4@udayton.edu).

E. Shin is with University of Dayton Research Institute, Dayton, OH 45469 USA

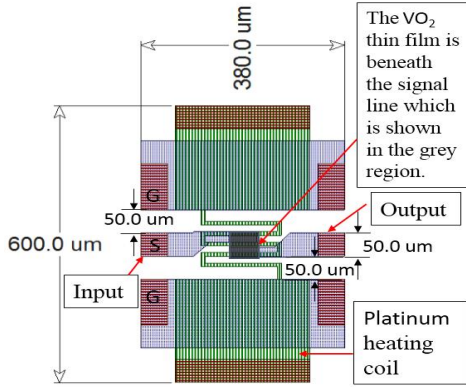

Figure 1. The top view of a VO₂ thin film series SPST switch, showing the coplanar waveguide structure. The VO₂ thin film is beneath the signal line which is shown in the dark region, and this switch has 50 μm width and 10 μm gap between coupled lines.

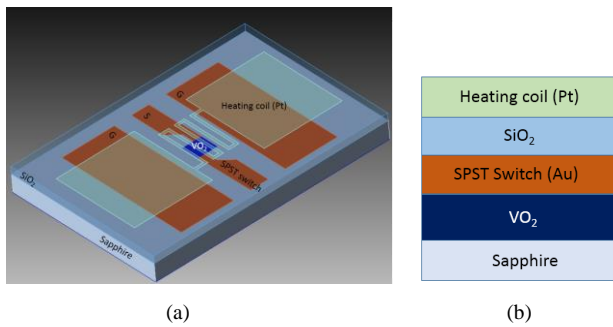

Figure 2. (a) The top view of layers of the VO₂ thin film switch; (b) Cross-sectional view showing the platinum (Pt) heating coil on the top layer, then SiO₂, Au, VO₂, and sapphire substrate.

device off. At temperatures above 68°C, the VO₂ film becomes a conductor allowing signal to go through. For better impedance matching, the switch is designed to work with a transmission line characteristic impedance of 50 Ω.

The overall size of the device is 380 μm x 600 μm. The small rectangular dark region in the middle of Figure 1 is the VO₂ thin film layer introduced in the coupling gap of the input/output signal lines. The platinum (Pt) heating coil is introduced on top of the VO₂ thin film using a SiO₂ isolation layer. The heating coil is shown as a meandering line (green in color). The marked G, S, G (stands for Ground, Signal, Ground) in Figure 1 are part of the CPW line conductor, typically made of Au. The layers of the VO₂ thin film switch are VO₂/Au/SiO₂/Pt on a sapphire substrate shown in Figure 2 with the Pt layer as the top layer. The corresponding thicknesses are 0.35 μm for VO₂, 0.5 μm for Au, 0.3 μm for SiO₂, and 0.1 μm for Pt.

III. EXPERIMENT

To fabricate the device, the VO₂ layer was first deposited uniformly on the whole wafer using a pulsed laser deposition technique. Then VO₂ was patterned and dry etched to remove unwanted areas. The standard lift-off process was used for Ti/Au thin film layer of ~ 500 nm to fabricate the CPW structure (G, S, G). After that, the functional device was

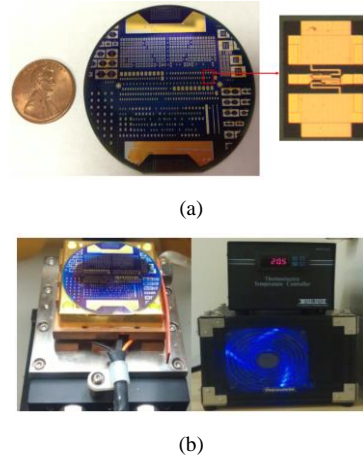

Figure 3. (a) The photos of VO₂ thin film series single-pole single throw (SPST) switch. (b) The heating station and temperature controller.

passivated by a layer of 300 nm silicon dioxide by PECVD at 300 °C followed by a thin layer of platinum heating coil on the top.

To obtain pristine VO₂ thin film is critical in tunable device fabrication. A typical VO₂ deposition uses a 248 nm excimer laser, striking a target of vanadium disk, with the laser energy density of 3.5 J/cm² at 10 Hz repetition rate. A reactive deposition is performed at a substrate temperature of 500°C in an optimized oxygen partial pressure. In pulsed laser deposition of VO₂, oxygen partial pressure determines the quality of the film. Three different oxygen pressure conditions were studied, which are, 25 mTorr, 35 mTorr and 45 mTorr. Grain size and film composition were compared for these conditions. Samples fabricated on silicon with exactly same deposition conditions were used, for better imaging in a scanning electron microscope. The X-ray diffraction (XRD) is used as another metrology tool to identify the crystal structure of VO₂ film.

All fabricated devices in this article were tested using swept frequency scattering parameter measurements up to 15 GHz. The return loss (S₁₁) and insertion loss (S₂₁) were obtained for the device while sitting on a temperature controlled stage, and using on-wafer probes. First, each single device was tested at room temperature with external controller set at 20°C. The testing setup is shown in Figure 3. A HP 8720B network analyzer was used for experimental measurements, using a probe station and cascade SP-ACP40-GSG-150-C probes. The probes were placed in the left edge and right edge of the transmission line for the swept frequency S-parameter measurement. Figure 3(a) shows the fabricated VO₂ thin film series single-pole single throw switch on the wafer, and this wafer is a 2" sapphire substrate. Figure 3(b) shows the heating station. A temperature controller is used to heat the wafer and control the temperature of measurement from 20 °C to 100 °C.

IV. RESULTS AND DISCUSSIONS

Figure 4 shows SEM pictures of the VO₂ grain size on

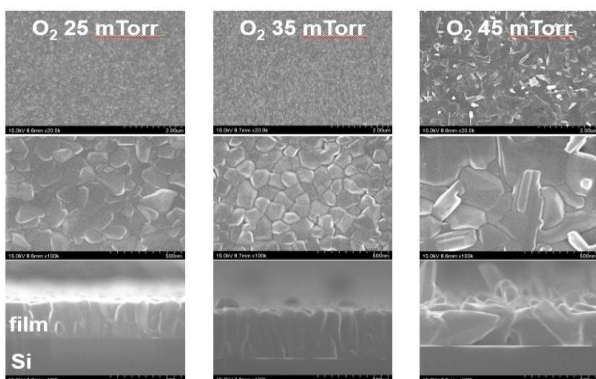

Figure 4. Visual comparison of VO₂ grain size on silicon substrate for each oxygen partial pressure. (Top view: 20k and 100k magnification)

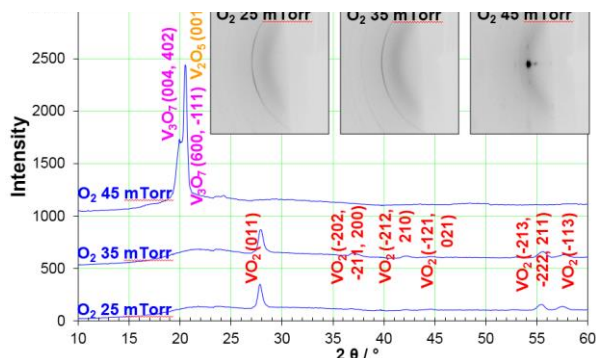
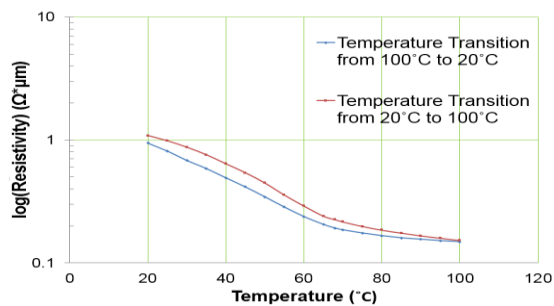

Figure 5. XRD measurement of vanadium oxide thin film of each oxygen condition.

silicon substrate at each oxygen partial pressure. The grain sizes are different in the films processed under different oxygen conditions. The film using 35 mTorr oxygen partial pressure condition has more uniform and finer grains compared to 25 mTorr and 45 mTorr conditions. At 25 mTorr, the grain size is around 250 nm, at 35mTorr condition, the grain size is around 100 nm, and at 45 mTorr condition, the grain size is around 300 ~ 500nm. Figure 5 shows the XRD measurement on each sample. The films formed from 25 mTorr and 35 mTorr partial oxygen pressure conditions is VO₂, but the one from 45 mTorr condition is V₂O₅ instead of VO₂. This result shows the VO₂ thin film can be obtained from oxygen partial pressure of 25 mTorr and 35 mTorr conditions. Therefore, electrical measurements of these conditions are necessary to distinguish further.

The resistivity measurement results of all three conditions on glass substrate are shown in Figure 6, and this figure indicates that vanadium oxide films on glass substrate deposited at 45 mTorr condition has different resistivity vs. temperature properties from other two conditions. Although there's no significant indication on material difference from XRD measurement for 25 mTorr and 35 mTorr cases, the resistivity measurement on both conditions help address the difference. From the measurements, vanadium oxide film with 25 mTorr processing condition has only one order of magnitude change on resistivity from room temperature (20°C) to high temperature (100°C). And the vanadium oxide film deposited at 35 mTorr has as high as three orders of magnitude change compared to two orders of magnitude change at 45



(a)

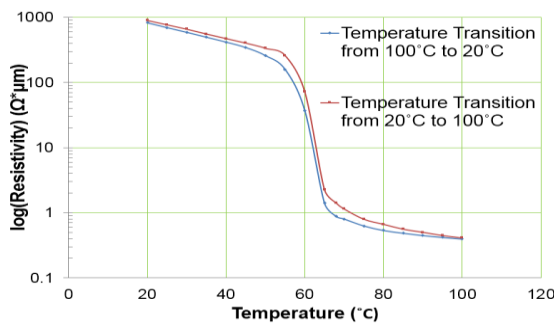

(b)

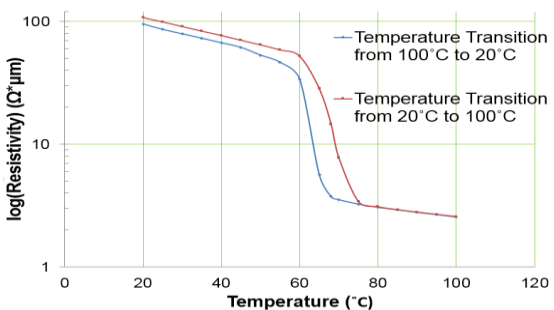

(c)

Figure 6. Resistivity measurements of vanadium oxide films on glass substrate deposited at (a) 25 mTorr, (b) 35 mTorr, and (c) 45 mTorr.

mTorr processing condition. From all these analyses, 35 mTorr oxygen partial pressure is chosen as the processing condition for device fabrication due to its highest resistance change in the metal-insulator transition.

Moreover, the measured results show that the resistivity of the VO₂ films is substrate dependent as well. Compared to glass substrate, sapphire substrate has even better phase transition performance with less hysteresis between room temperature and high temperature [26]. Therefore, for the

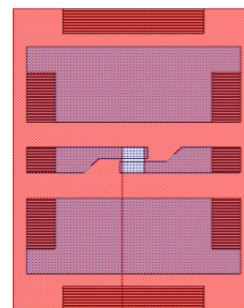

Figure 7. SPST switch without SiO₂ and heating coil Pt layers.

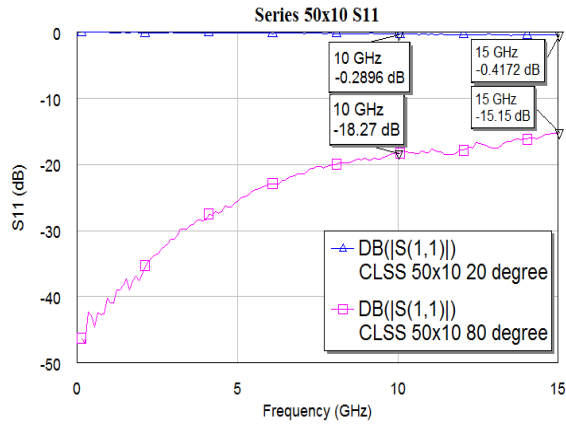

Figure 8. The measured S_{11} of VO_2 coupled line series SPST switch without SiO_2 and heating coil Pt layers at temperatures 20°C and 80°C.

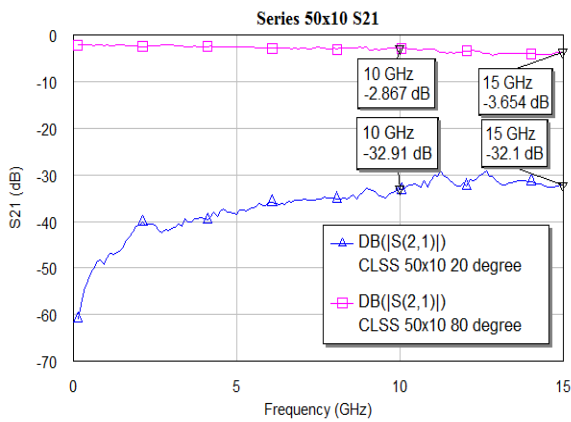

Figure 9. The measured S_{21} of VO_2 coupled line series SPST switch without SiO_2 and heating coil Pt layers at temperatures 20°C and 80°C.

better quality, sapphire substrate was selected to fabricate RF devices in this research.

The VO_2 thin film series SPST switch is a multi-layered device. To carefully study VO_2 performance throughout fabrication process, the measurements were separated into two stages. The first stage was to measure the S-parameter only when VO_2 and Au layers were deposited. The Figure 7 shows the structure of SPST without the SiO_2 and Pt heating coil layer. The measured S_{11} is greater than -1 dB at 20 °C, and it is less than -20 dB at 80°C shown in Figure 8. The measured S_{21} is less than -30 dB at 20°C, and it is greater than -4 dB at 80°C as shown in Figure 9.

When the temperature was at 20°C, VO_2 acted like an insulator and the RF signal would not pass through the transmission line. When the temperature was increased to 80°C, the VO_2 acted like a conductor, and most input signal was able to pass through it. The VO_2 thin films series SPST switch showed that the phase transition was achieved by integrating the VO_2 thin film with SPST switch.

The second stage was to measure the S-parameters when VO_2 , Au, SiO_2 and Pt layers were deposited. Figure 10 shows the SiO_2 and Pt heating coil layers have been fabricated with the series SPST switch. The measured result of the S_{11} is worsened at 20°C, and it is below -15 dB at 80°C as shown in

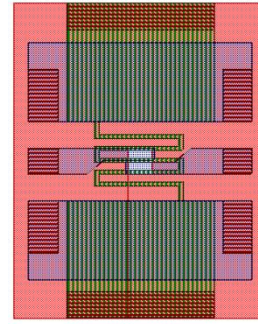

Figure 10. The SPST switch with SiO_2 and heating coil Pt layers.

Figure 11. The S_{21} is less than -20dB at 20°C, and it is greater than -5dB at 80°C as shown in Figure 12. Compared to the measured S_{11} and S_{21} in the first stage, the measured results of S_{11} with SiO_2 and Pt layers are around 6 dB worse than the measured S_{11} without SiO_2 layer, and the measured results of S_{21} with SiO_2 and Pt layers are around 10 dB worse than the measured S_{21} without SiO_2 layer. Therefore, such experimental results have showed that the addition of SiO_2 has some negative effect on the performance of VO_2 . However the XRD measurement on the substrate at this stage shows no sign of VO_2 crystal structure change. Further study will be conducted on understanding the effects of SiO_2 deposition on VO_2 .

The commercial microwave frequency simulation tool, AWR from NI was used to import the measured results of the

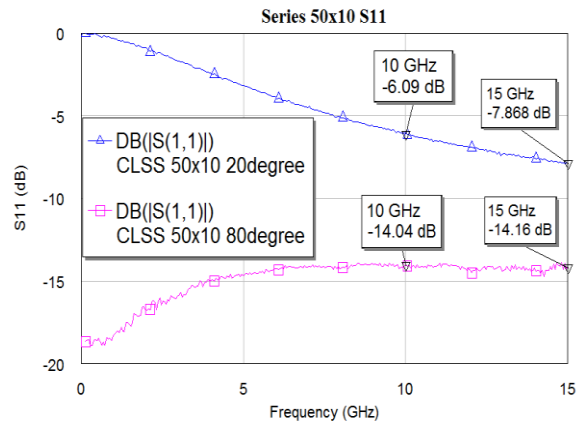

Figure 11. The measured S_{11} of VO_2 coupled line SPST switch with SiO_2 and heating coil Pt layers at temperatures 20°C and 80°C.

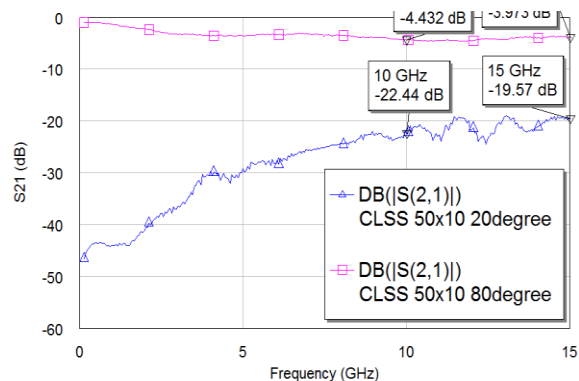

Figure 12. The measured S_{21} of VO_2 coupled line SPST switch with SiO_2 and heating coil Pt layers at temperatures 20°C and 80°C.

fabricated device, develop a schematic electrical circuit model, and compute the scattering parameters over the predefined frequency range. Two electrical models were used to find the different resistances of VO₂ at different temperature conditions, 20°C and 80°C by matching the S-parameters (S₁₁ and S₂₁) of the measured results without the SiO₂ and Pt layers.

The input and output ports of the electrical models are connected with transmission lines in the form of CPW structure. In the electrical model, W is the width of the transmission line, S is the gap between the transmission line and the ground, and L is the length of the transmission line. Based on the design of the devices, W is 50 μm, S is 50 μm, and L is 165 μm.

The electrical model in Figure 13 is used to match the S₁₁ and S₂₁ at 20°C. The resistor R₃ in this electrical model is used to determine the resistance of VO₂ thin film varistor and the capacitor C₃ is used to represent the capacitance between the transmission lines. The resistance of VO₂ is around 73.3K Ω, and the capacitance of C₃ is 0.0058pF in the insulating state of VO₂ at 20° C. The capacitors of C₁, C₂ and the resistors of R₁,

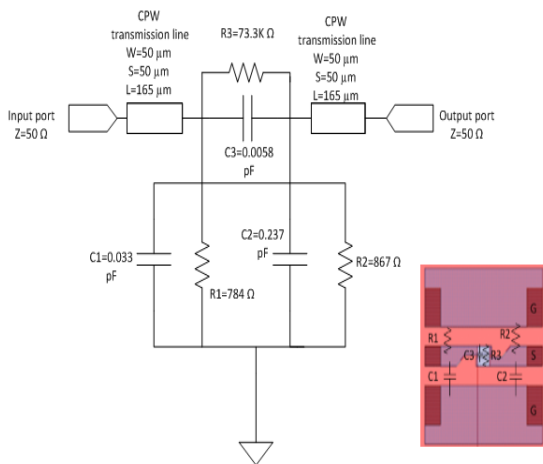

Figure 13. Electrical model matching results for 20°C.

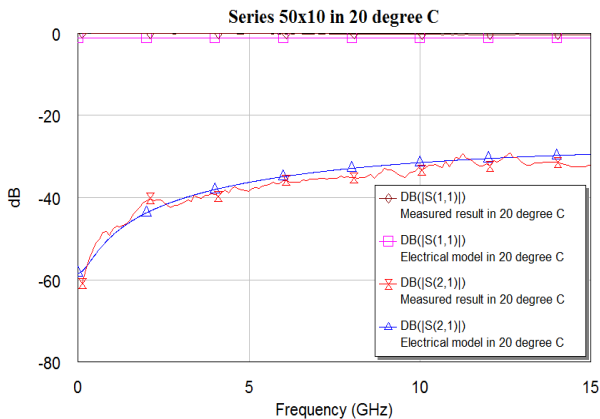

Figure 14. The S₁₁ and S₂₁ of measured results and S₁₁ and S₂₁ of electrical model matched at 20 °C.

R₂ represent the capacitance and resistance between the signal line and ground plan of the CPW structure. The corresponding

capacitance of C₁ is 0.033 pF, C₂ is 0.237 pF, and the resistance of R₁ is 784 Ω, and R₂ is 867 Ω based on fabricated device structure. The matched results are shown in Figure 14.

Figure 15 shows the other electrical model which is used to match S₁₁ and S₂₁ at 80°C temperature. Compared to the electrical model in Figure 13, there is no capacitance between the two transmission lines in the electrical model of Figure 15 because VO₂ becomes conducting when the temperature is increased to 80 °C and the two transmission lines are connected by the VO₂. In this electrical model, the resistor R₃ represents the resistance of VO₂ in the conducting state, which is around 13 Ω. The capacitors of C₁, C₂ and the resistors of R₁, R₂ represent the capacitance and resistance between the signal line and ground plane of the CPW structure. In this case, the capacitance of C₁ is 0.0165 pF, C₂ is 0.117 pF, and the resistance of R₁ is 300 Ω, and R₂ is 866 Ω. The matched results are shown in Figure 16.

From the matching of the results, the resistance of the VO₂ is 73.3 KΩ at 20°C and becomes lower resistance of about 13 Ω at the temperature of 80°C. The resistance ratio is 5600 which is similar magnitude level of VO₂ resistivity ratio

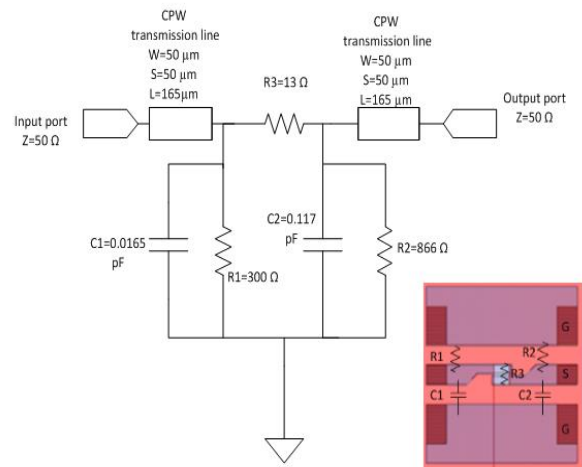

Figure 15. Electrical model matching results for 80°C.

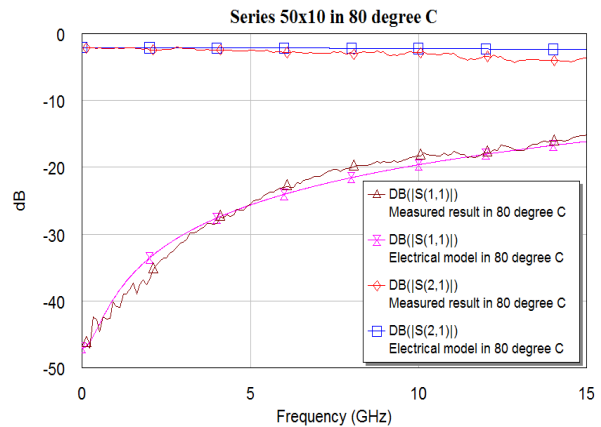

Figure 16. The S₁₁ and S₂₁ of measured results and S₁₁ and S₂₁ of electrical model match results at 80°C.

outlined by Figure 6(b).

V. CONCLUSION

In this article, the impact of oxygen partial pressure on VO₂ thin film deposition conditions were studied. High quality VO₂ thin films were obtained for the oxygen partial pressure of 35 mTorr. VO₂ thin films exhibited sharp insulator to metal transition at 68°C, with the resistance of the thin film varistors changing by more than three orders of magnitude. A series single-pole single throw (SPST) switch built using VO₂ thin film showed that the isolation is better than 30 dB at room temperature and the insertion loss is below 5 dB at temperatures above 68°C. Although VO₂ based switches shows less ideal RF performance compared to RF MEMS switches [27-29], the switching time could be as fast as 5 ns [30-31] compared to 25 μs of a MEMS switches [29] and such devices have no fatigue concern which is typical in RF MEMS switches. In addition, the manufacturing cost could be much lower with such simple device structure.

It's also worth mentioning that the measured results showed that the VO₂ is affected by the subsequent SiO₂ deposition process. Other alternate low temperature passivation layers will be investigated in the future. Other future plans for this research also include study of applications of VO₂ in reconfigurable antennas, varactors, and tunable inductors and ultimately using integrated Pt heating coil to control the SPST switches instead of using external heating source. Standalone devices could have broader applications in reconfigurable electronics.

Acknowledgements: This research was sponsored in part by the Air Force Research Laboratory Sensors Directorate (AFRL/Rydi) under the AFRL Research Collaboration Program (RCP) Contract FA8650-13-C-5800.

REFERENCES

- [1] F. J. Morin, "Oxides Which Show a Metal-to-Insulator Transition at the Neel Temperature", *Phys. Rev. Lett.*, 3, 34-36, 1959
- [2] A. Zylbersztein and N. F. Mott, "Metal-insulator transition in vanadium dioxide", *Phys. Rev. B*, 11, 4383-4395, 1975
- [3] R. Cabrera, E. Merced, and N. Sepúlveda, "Performance of Electrothermally Driven VO₂-Based MEMS Actuators", *Journal of Microelectromechanical Systems*, Vol. 23, No. 1, Feb. 2014
- [4] J. Zhang, E. Merced, and N. Sepúlveda, "Modeling and Inverse Compensation of Nonmonotonic Hysteresis in VO₂-Coated Microactuators", *IEEE/ASME Transactions on Mechatronics*, Vol. 19, No. 2, pp. 579-588, April, 2014
- [5] N. Dávila, E. Merced, and N. Sepúlveda, "Electronically Variable Optical Attenuator Enabled by Self-Sensing in Vanadium Dioxide" *IEEE Photonics Technology Letters*, Vol. 26, No. 10, May 15, 2014
- [6] Pedro Cintas, *The Road to Chemical Names and Eponyms: Discovery, Priority, and Credit*, Angewandte Chemie International Edition, 2004
- [7] George F. Vander Voort. *Metallography, principles and practice*, ASM International, 1999
- [8] François Cardarelli, *Materials handbook: a concise desktop reference*, Springer, 2008
- [9] Norman N. Greenwood, Alan Earnshaw, *Chemistry of the Elements*, Oxford, 1984
- [10] G. Brauer, *Handbook of Preparative Inorganic Chemistry*, 2nd Ed., Academic Press, 1963
- [11] US patent 5450053 A, Honeywell, "Use of vanadium oxide in microbolometer sensors", issued: Sep 12, 1995.
- [12] P.F. Hood and J. F. DeNatale, "Millimeterwave dielectric properties of epitaxial vanadium dioxide thin films", *J Appl. Phys.*, vol.70, No.1, pp. 376-381, 1991.
- [13] J. Barker, Jr., H. W. Verleur, and H. J. Guggenheim, "Infrared optical properties of vanadium dioxide above and below the transition temperature," *Phys. Rev. Lett.*, vol. 17, No. 26, pp. 1286-1289, 1966.
- [14] J. Wei, Z. Wang, W. Chen, and D. H. Cobden, "New aspects of the metal-insulator transition in single-domain vanadium dioxide nanobeams," *Nature Nanotechnol.*, vol. 4, pp. 420-424, 2009.
- [15] J. F. De Natale, P. J. Hood, and A. B. Harker, "Formation and characterization of grain-oriented VO₂ thin films," *J. Appl. Phys.*, vol. 66, pp. 5844-5850, 1989.
- [16] E. Merced, X. Tan, and N. Sepúlveda, "Strain energy density of VO₂-based microactuators," *Sens. Actuators A, Phys.*, vol. 196, pp. 30-37, Jul. 2013.
- [17] D. P. Partlow, S. R. Gurkovich, K. C. Radford, and L. J. Denes, "Synthesis of vanadium dioxide thin films from vanadium alkoxides," *J. Appl. Phys.*, vol. 70, pp. 443-452, 1991.
- [18] G. A. Rozgonyi and D. H. Hensler, "Structural and electrical properties of vanadium dioxide thin films," *J. Vac. Sci. Technol.*, vol. 5, No. 6, pp. 194-199, Nov. 1968.
- [19] S. Lysenko, A. R'ua, V. Vikhnin, F. Fern'andez, and H. Liu, "Optical nonlinearity and structural dynamics of VO₂ films," *J. Appl. Phys.*, vol. 105, pp. 043502-1-043502-6, 2009.
- [20] G. J. Kovacs, D. Burger, I. Skorupa, H. Reuther, R. Heller, and H. Schmidt, "Effect of substrate on the insulator-metal transition of vanadium dioxide thin films", *J. Appl. Physics.*, vol. 109, pp. 063708-1, 2011.
- [21] J. Givernaud, A. Crunteanu, J.C. Orlianges, et. al., "Microwave power limiting devices based on the semiconductor metal transition in Vanadium oxide thin films", *IEEE Transactions on Microwave Theory and Techniques*, vol. 58, No.9, pp. 2352-2361, 2010.
- [22] A. Crunteanu, J. Givernaud, et al., "Voltage and current activated metal-insulator transition in VO₂ based electrical switches: a lifetime operational analysis", *Science and Technology of Adv. Materials*, vol. 11, pp. 1-6, 2010.
- [23] H. T. Kim, B. G. Chae, D. H. Youn, S. L. Maeng, G. Kim, K. Y. Kang, and Y. S. Lim, "Mechanism and observation of Mott transition in VO₂-based two- and three-terminal devices," *New J. Phys.*, vol. 6, p. 52, May 2004.
- [24] J. Sakai and M. Kurisu, "Effect of pressure on the electric-field-induced resistance switching of VO₂ planar-type junctions," *Phys. Rev. B, Condens. Matter*, vol. 78, no. 3, p. 033 106, Jul. 2008.
- [25] B. J. Kim, Y. W. Lee, S. Y. Choi, S. J. Yun, and H. T. Kim, "VO₂ Thin-Film Varistor Based on Metal-Insulator Transition", *IEEE Electron Device Letters*, vol. 31, No. 1, Jan, 2010
- [26] G. Subramanyam, E. Shin, D. Brown, H. Yue, "Thermally controlled vanadium dioxide thin film microwave devices", *Circuits and Systems (MWSCAS), 2013 IEEE 56th International Midwest Symposium*, pp. 73-76, Aug. 2013
- [27] M. Daneshmand, S. Fouladi, R. R. Mansour, M. Lisi, and T. Stajcer, "Thermally Actuated Latching RF MEMS Switch and Its Characteristics", *IEEE Transactions on Microwave Theory and Techniques*, vol. 57, no. 12, Dec. 2009
- [28] R. Stefanini, M. Chatras, P. Blondy, G.M. Rebeiz, "Miniature RF MEMS Metal-Contact Switches for DC-20 GHz Applications", *Microwave Symposium Digest (MTT), 2011 IEEE MTT-S International*, pp.1-4, June 2011
- [29] R. Chan, R. Lesnick, D. Becher, and M. Feng, "Low-Actuation Voltage RF MEMS Shunt Switch with Cold Switching Lifetime of Seven Billion Cycles", *Journal of Microelectromechanical Systems*, vol. 12, no. 5, Oct. 2003
- [30] J. Leroy, A. Crunteanu, A. Bessaudou, F. Cosset, C. Champeaux, and J.-C. Orlianges, "High-speed metal-insulator transition in vanadium dioxide films induced by an electrical pulsed voltage over nano-gap electrodes," *Appl. Phys. Lett.*, vol. 100, no. 21, pp. 213 507-1-213 507-4, May 2012.
- [31] [5] Y. Zhou, X. Chen, C. Ko, Z. Yang, C. Mouli and S. Ramanathan, "Voltage-Triggered Ultrafast Phase Transition in Vanadium Dioxide Switches", *IEEE Electron Device Letters*, VOL. 34, NO. 2, Feb. 2013