

A VARSITY VOLLEYBALL COACH'S HANDBOOK

MASTER'S PROJECT

Submitted to the Department of Education,  
University of Dayton, in Partial Fulfillment  
of the Requirements for the Degree  
Master of Science in Education

by

Martha R. Cain  
University of Dayton  
Dayton, Ohio  
June, 1995

UNIVERSITY OF DAYTON ROESCH LIBRARY

Approved by:

Official Advisor

## CHAPTER I

### INTRODUCTION

#### Purpose of the Study

Educational programs throughout most states are aimed at molding young students' minds and talents primarily in academic areas. Those areas in most school curricula include English, mathematics, science and history.

In addition to providing for the academic training and development of these students, many schools also provide the opportunity for students to participate in extracurricular activities. One of the most popular of these is athletics.

Many sporting activities are available to today's students. Athletic competition for high school and college females is now accepted as an important part of American society. The Ohio High School Athletic Association is in charge of the regulations and the state tournaments for the following eleven sports: golf, cross-country, volleyball, soccer, tennis, field hockey, basketball, gymnastics, swimming, track and softball.

Athletics can become a major part of a student's life. This can include participating in volleyball, which has grown to be one of the most popular sports in Ohio. Since thousands of students participate in high school volleyball each year, the writer was aware for the need of a volleyball coach's handbook.

Achievement in any sports program is attributed to the person leading the athletes - - the coach. People who coach are expected to teach sport skills. The coach is very important in the development of a volleyball player. Using current application of the rules and up-to-date techniques requires specific training.

In order to assist in the skills training of varsity volleyball coaches, the writer devoted a part of the handbook to current teaching methods.

Since the coach needs to teach current technique methods, the writer also devoted a part of the handbook to volleyball drills. These drills are related to the individual fundamental skills of the game and also to the development of the player and team.

#### Problem Statement

The purpose of this study was to design a coach's handbook to be used by varsity volleyball coaches.

#### Definition of Terms

Ohio High School Athletic Association (OHSAA) is the governing body that makes up the rules and regulations for Ohio high schools.

Ohio High School Volleyball Coaches Association (OHSVCA) is the governing body that helps to regulate high school volleyball coaches in Ohio.

#### Limitations

This writer feels that the handbook is limited in that it is beneficial for varsity volleyball coaches but not for the beginning coach. The writer assumes that the varsity coach has had experience coaching volleyball and already possesses knowledge relating to the fundamentals of the game. Therefore, it is limited in that an inexperienced coach who has not previously implemented multiples offenses and defenses in game situations may not be able to understand and use these strategies explained in the handbook.

## CHAPTER II

### REVIEW OF THE LITERATURE

#### History of Volleyball

The year 1995 marks the 100th anniversary of the invention of volleyball and enthusiasts worldwide are ready for a centennial celebration. The United States of America Volleyball Association (USAV), the National Governing Body for the sport in this country, in conjunction with the Federation Internationale de Volleyball (FIVB) is planning an unforgettable year in commemoration of the sport's inception. However, in order to understand the magnitude and scope of the worldwide centennial celebration, an explanation of the history of volleyball is necessary.

In 1895, William G. Morgan was the physical director of the Young Men's Christian Association (YMCA) in Holyoke, Massachusetts. He was in charge of developing activities for many of the local businessmen who would frequent the establishment in search of physical fitness. (Asher, 1995) The sport of basketball had been invented four years earlier; but many businessmen found the game too physically taxing. Morgan invented a game known as mintonette, which incorporated aspects of badminton (the net), basketball (the ball), baseball (the game was originally played in innings), and handball (the hands were used to hit the ball over the net).

The objective was to hit the ball back and forth with the hands. Each team was allowed to play with an unlimited number of players. The team was permitted three outs before they had to forfeit the ball. The game grew quite popular with the Holyoke businessmen in a very short time. Yet, the name "Mintonette" did not seem to fit.

Several months after the introduction of mintonette Springfield College Professor Alfred T. Halstead convinced Morgan to change the name to volleyball because it was more descriptive and marketable to a sport-minded public. (Asher, 1995)

By 1912, the YMCA formed a special committee and developed major rule changes. The court was enlarged to thirty-five feet by sixty feet; the net was raised to seven feet six inches; serve rotation of players was incorporated, as well as the establishment of the two-out-of- three game match. In 1916, the YMCA in conjunction with the National Collegiate Athletic Association (NCAA) published men's rules. The net was elevated to eight feet and the game was concluded at fifteen points. Volleyball as it is today had begun. (Asher, 1995)

The popularity of the game of volleyball spread from this country in the early part of the 20th century. United States missionaries introduced the game into Asia and Russia in 1918-1919, and the United States armed forces introduced volleyball to Europe during World War II. The popularity of the sport invited the formation of the United States Volleyball Association (USVBA) in 1928. (Asher, 1995) In that year, the Volleyball Rules Committee of the YMCA was reorganized to become the USVBA, whose purposes were to coordinate the volleyball rules on a national level and to create a national open tournament. The rules of the game, as well as information on various volleyball activities such as tournament standards and qualifying officials have been published annually by the USVBA since its inception.

By 1948, it soon became evident that an international governing body was needed to oversee the sport on such a huge scale. As a result, the United States and twelve other nations joined together to form the FIVB. The first World Championship (for men) followed immediately in 1949, and the first women's championship was held in 1952. The game of volleyball was added to the Olympic Games in 1964.(Asher, 1995) Today, all over the world, volleyball players, coaches, referees and spectators will celebrate the 100th anniversary of this immensely popular sport!

## Participation in Sports by Children and Adolescents

Sport participation for children and adolescents has served an important role in American society since the turn of the century, according to Maureen Weiss, Associate Professor, Department of Physical Education and Human Movement Studies at the University of Oregon. She reported that approximately twenty million children between the years of six and eighteen participate in sports. She insists that sports contribute to positive aspects of development which occur in sport participation such as volleyball, when children are guided by caring, sensitive and informed coaches.

Her article entitled "Youth Sports: Is Winning Everything" was published in Childhood Education (1989). One reason according to Weiss, why children and adolescents participate in sports, is that sports provide them with a chance to be with friends and share in the enjoyment of competition. Another reason why they participate is it allows them to get in shape or maintain their current fitness levels. The third reason of participation is to learn the fundamental skills of a particular sport. And finally, the last reason is that children can develop different abilities for several sports which allows them to develop a range of choice for adult leisure activities such as volleyball.

Sam Chambers, Professor at the University of Virginia provides further reasons why children and adolescents participate in sports. He claims that the National High School Federation lists over five million high school students participating in organized sports including volleyball. In his survey of over 1,500 youths on participation motivation, he found that fun and enjoyment were the most popular reasons. The second reason for participation was skill development followed by status and excitement. Additional reasons why children and adolescents participate in sports relate to fitness, energy and tension release. Finally the last two reasons, according to Chambers are achievement and friendship.

These results can be found in the The Elementary School Journal (1991), "Factors Affecting Elementary School Students Participation in Sports". Chambers describes fun as an overall measurement of a child's satisfaction with game performance, and can be considered an indicator of his or her perceived individual motives for participation.

Helen Pointdexter and Carol Mushier in their book, Coaching Competitive Team Sports for Girls and Women (1973), list additional reasons why youngsters participate in sports. They feel that number one reason children and adolescents participate is the attitude of their peer group toward athletic competition. Their findings indicate that status recognition, glory and social acceptance are the top reasons. Additional reasons include enjoyment of activity, personal satisfaction and outlet for aggression. Many students' goals are related to the social acceptance and the status of the activity in their particular environment.

Pointdexter and Mushier believe that the coach who is committed to achieving the potential values of the program, must remain alert to student motives for participation. They also believe that the coach needs to be a strong leader to create positive attitudes in her players and provide a socially desirable climate in competitive situations.



## Principles of Effective Coaching

The sport of volleyball is one of eleven sports that is offered to high school athletes in the state of Ohio to participate in. It is the job of the coach to run an efficient and effective program. In order to do so, the coach has many roles to perform. These roles such as team manager, organizer, administrator and professional are all extremely important to help the coach run a competitive program each year.

An important principle of effective coach according to Donald E. Fuoss and Robert J. Troppman, authors of Effective Coaching, A Psychological Approach (1981), is team management. The role of management is to plan, organize, integrate and inter-relate organizational activities and resources for the purpose of achieving common objectives. The responsibility of the coach is to direct the program so that it is effective in goal accomplishment.

Coaches select, slot and integrate the human elements and resources available to them so that the resultant coordinated activity will optimize performance. Typically, resources are identified as people, materials, machines, money and methods. Management is a process that is dynamic and changing. A manager is concerned with effectiveness and efficiently achieving organization on program objectives and goals. Fuoss and Troppman believe that effectiveness is "doing the right things" and efficiently is "doing things right" (1981).

A decision is made about a plan; it has implications for organizing; leadership is necessary to implement the plan through joint human endeavor and the resulting performance must be controlled and monitored throughout. In each instance, a manager has to make decisions pertaining to what is to be done; when, where and how it is to be done, who it is to do it; and behind each of the decisions is why.

Management functions of coaching require much conceptualization, decision making and coordination. When this does not occur, the collective group effort is

uncoordinated, inefficient and ineffective.

Another principle of effective coaching relates to organization. The importance of sound organization should never be underestimated according to Ralph Sabock, author of The Coach (1979). Sabock claims that regardless of the sport, the first phase of organization is for the head coach to begin by organizing a personal philosophy of coaching and to determine the way the program should be conducted.

Since the head coach is going to provide the proper leadership to a coaching staff and a team, it is imperative that the coach's thoughts be organized well enough to provide the necessary direction. The team should have a good idea of what needs to be done, as well as have general and specific guidelines that will provide direction of the whole program. If the coach is aggressive, well disciplined, organized and believes in playing by the rules, the team will probably reflect this philosophy.

Sabock believes that there is no detail too small to attend to in order to run an efficient program. A coach should have a basic plan on how to get things done. He describes numerous duties that need to be attended to during the pre-season, season and post-season.

Sabock feels that during the pre-season, the coach needs to attend coaching clinics, sport medicine clinics and Cardio-pulmonary resuscitation classes. Also, interviewing and hiring the coaching staff needs to be done. Player handbooks need to be reviewed and updated along with organizing the summer practice schedule. Equipment inventory should be taken and all equipment evaluated as to its usability. New equipment can be order while the old is repaired or thrown out.

During the season, according to Sabock, not only does the coach need to be organized in his daily practice preparation, but also in pre-game, games and post game activities. All necessary items for games such as water bottles, towels and equipment should be checked and kept track of in a organized manner. Statistic sheets, emergency

medical forms and video equipment all need to be accessible for immediate use.

The post-season is the time for the coach to attend league, district state awards meeting and all-star matches. The coach should have available and in an organized manner, the team's statistics and individual players for these meetings for the other coaches to observe and use for voting purposes. The season scrapbook highlights all the events of the season and takes a minimal time to put together, if the coach keeps all the clippings, statistics, photographs etc. in a systematic order throughout the year.

Sabock admits that he cannot describe every duty a coach needs to perform however, he does insist that organization is the key to an effective program.

Another principle of effective coaching relates to proficient administration. Coaching administration is defined as "the process you use to guide your program toward a goal", according to Larry Leith, author of Coaches Guide to Sport Administration (1990). The process of administration refers to the planning, organizing, leading and controlling that takes place to accomplish coach objectives.

Planning is determining in advance what is to be done, and how it is to be done and who is going to do it. Leith also explains planning as making day-to-day objectives and decision. Planning requires the coach to establish objectives and standards that can be used to determine whether the desired goal is achieved. This results in more efficient use of time and human resources.

Organizing involves establishing relationships between the activities to be performed, the people who will perform them and the physical factors that are required to accomplish the program's goals. Leith claims that is very important to learn to organize clear-cut responsibilities among the players, coaching staff and parents.

The leadership function involves maintaining effective working relationship with sport administrators, parents athletes and fellow coaches on a daily basis. The coach needs to motivate athletes, develop effective communication and handle conflicts.

The final link in the functional chain of coaching administration is control. Stated simply it involves checking on all phases of the program to see if things are going as planned. The coach needs to measure the actual performance results, compare those results to the objectives and take some form of corrective action if there are deviation from the original objectives.

The coach as a professional is another essential principle of effective coaching. The book, Guide to Effective Coaching (1982), written by Billie Jones, Janet Wills, Rachael Peters and Dewayne Johnson devotes several chapters to this topic. Jones, Wills, Peters and Johnson believe coaches have a great obligation as molders of youth in the social and moral sense. As a responsible person, a coach should exemplify the behaviors, described in the National Code of Ethics for high school coaches. The Code of Ethics States:

- Exemplify the highest moral character, behavior and leadership.
- Respect the integrity and personality of the individual athlete.
- Abide by the rules of the game in letter and in spirit.
- Respect the integrity and judgment of sports officials.
- Demonstrate a mastery of continuing interest in coaching principles and techniques through professional involvement.
- Encourage a respect for all athletics and their values.
- Display modesty in victory and graciousness in defeat.
- Promote ethical relationships among coaches.
- Fulfill responsibilities to provide health services environment free of safety hazards.
- Encourage the highest standards of conduct and scholastic achievement among all athletes.
- Seek to inspire good health habits and training rules.
- Strive to develop in each athlete the qualities of leadership, initiative and good judgment (Jones, 1982)

A professional is a person who spends years learning about relevant tasks and problems, who can operate independently on basic principles and be held responsible for decisions and outcomes. A professional also brings new members into the profession and continues to study and seek new knowledge.

Harold J. Vanderzwagg, author of Policy Development in Sport Management (1988), feels that the coach represents different things to different people. To some, the coach is a teacher, trainer, or a counselor, while to others he is a disciplinarian, manager and public relations agent. All of these roles are required of a coach in addition to the need to have thorough knowledge of the sport. The coach is expected to relate well to a variety of constituencies, students, parent, administrators, other coaches the news media, fans and the general public. Besides attempting to fulfill these roles he is hired to win games.

Coaching can be a life-long occupation or a pleasant, temporary avocation. Either way, when it is pursued, it can be exciting, demanding and consuming. No one can perfectly fulfill all of the roles of a coach, but an honest effort, study and devotion to the task can carry most potential coaches through to the following goals: the development of athletes to their fullest potential and the development of an efficient and effective volleyball program.

## CHAPTER THREE

### METHODOLOGY

The writer decided to review her personal library for ideas and information related to the topic areas of athletics, athletic management, sports and volleyball. Because the writer's library lacked some of the needed information, the writer located textbooks on coaching at the University of Dayton's Roesch library.

#### Review of Journals

Volleyball USA provided the author with the historical facts of volleyball. This journal is considered to be an excellent source of current volleyball information.

#### Review of Professional Textbooks

The writer selected textbooks from the University of Dayton's Roesch Library that pertained to her study. These texts, Policy Development in Sport Management, by Harold Vanderzwagg, and The Coach, by Ralph Sabock, along with Coaches Guide to Sport Administration, by Larry Leith, provided help in determining content for the handbook.

The writer used Winning Volleyball, by Al Scates, for information relating to specific types of offenses and defenses. Coach Scates won five collegiate volleyball national championships while coaching at The University of California at Los Angeles (UCLA).

Championship Volleyball, by Sue Gozansky, the Women's volleyball coach at the University of California at Riverside, was also chosen as a reference by the writer. Gozansky's team won the Division Two National Championship in 1982 and 1983. She has coached at Olympic development camps throughout the nation and on the international level. The writer used her book because she did an outstanding job of logically detailing the teaching progressions for each skill.

## Review of Handbooks

The Ohio High School Volleyball Coaches Association (OHSVCA) Drill Book provided the writer with drills for every volleyball skill. Each year at the clinic each coach who attends turns in a drill that will appear in next year's issue. The writer used all drills from the 1994 issue. This drill book has drills for every level of play: junior high, junior varsity and varsity.

The High School Volleyball Rule book published by the National Federation of State High School Associations provided the writer with the current rules and regulations.

The information gathered from all of the above sources enabled the writer to complete her handbook.

CHAPTER IV

RESULTS

A VARSITY VOLLEYBALL  
COACH'S HANDBOOK

MARTHA R. CAIN

JUNE, 1995



## HANDBOOK TABLE OF CONTENTS

| SECTION: | TITLE                                      |    |
|----------|--|----|
| I.       | COACHING PHILOSOPHY.....                   | 16 |
| II.      | EXPLANATION OF THE GAME.....               | 19 |
| III.     | TECHNIQUES .....                           | 21 |
|          | Serve.....                                 | 21 |
|          | Pass.....                                  | 23 |
|          | Set.....                                   | 25 |
|          | Spike .....                                | 28 |
|          | Block.....                                 | 32 |
|          | Dig.....                                   | 34 |
|          | Offense.....                               | 38 |
|          | Defense .....                              | 44 |
| IV.      | PRE-SEASON .....                           | 50 |
| V.       | SEASON.....                                | 52 |
| VI.      | DRILLS .....                               | 53 |
| VII.     | GAME PREPARATION AND RESPONSIBILITIES..... | 70 |
| VIII.    | POST-SEASON.....                           | 72 |
| IX.      | SUMMER PLANS.....                          | 73 |

## SECTION I

### COACHING PHILOSOPHY

Coaching philosophy is usually determined by the coach and her analysis of what constitutes a successful season.

The idealistic coach according to Al Scates, author of Winning Volleyball (1976), is one who is interested in developing the team's best potential. In attempting to achieve excellence, she stresses teamwork and wants each player to maintain her individuality. Sportsmanship and honor on and off the court are goals of the idealistic coach. She believes that every possible opportunity should be given to players with poorer skills to develop fundamental techniques. Consequently, she does not select a "starting six" until the less-skilled players are convinced that they were selected only after everyone had an equal chance to display their talents.

The idealistic coach divides her attention among all the players and gives substitutes a reasonable chance to try new positions. She allows the poor passer, setter, spiker, server, or digger to play or be substituted out of the game. She gives every player opportunities to improve weaker skills during game competition, thus building confidence and helping team members become all-around players.

Scates defines the realistic coach as most likely to choose and develop a starting line-up early in the season and to concentrate on "starters" during practice sessions. Her starting players are usually run through a rigorous conditioning program, and her substitutes are a member of the team as long as they maintain the desire to improve themselves. When they complain about their lack of playing time, they might be told that they should feel free to leave the squad.

The realist chooses an offense and defense suited to the abilities of the best players. She is not concerned with developing all-around players and relies on the best talents of each player to develop a winning team.

The writer feels that a coach needs to develop a unique philosophy that is a blend of both the idealist and the realistic coach. The writer is definitely interested in developing each individual's potential and the teams potential. Every possible opportunity should be given to each player to develop their fundamental skills.

The "starting six" is experimented with throughout summer tournaments and leagues. The pre-season scrimmages provide additional opportunities for the coach to try players in different positions. Then, after much thought and consideration, the starting rotation is chosen. Since the season lasts from August through November, and the athlete can play in over 20 matches, the starting six can change due to injuries, grades and player attitudes.

The writer feels that the way a player practices is a good indication of the way she will perform in the game. Therefore, the decision of the amount of playing time each player will be given is based on the quality of each player's practice time. The writer does not concentrate only on her starters and neglect the substitutes in practice or in games. As mentioned before, a coach never knows when a player will be injured, therefore all substitutes must be ready to play at any given time.

The writer tries to judge a player's volleyball skills by observing her athletic skills on the court. The writer believes in specialization. For example, if a player is not a good server, she will not serve in a game. If a player is not a very good passer, she will not participate in serve receive or play defense in the back row. The coach should try to have on the floor the best six players in every rotation. In order to do that, she must look at the rotation and analyze it for every rotation. (Even though a player does not play in a game,

she must still practice each skill every day so that if needed to play she would know how to perform that particular skill).

The coach should be concerned with developing each player's individual fundamental skills and helping her to become an all-around player. Hopefully, the entire volleyball program, beginning with middle school intramurals, and concluding at the high school varsity level, will help the coach to accomplish these goals.

## SECTION II

### EXPLANATION OF THE GAME

The National Federation of State High School Associations publishes a volleyball rules book every year which contains all the current rules of the game. This book contains a court diagram and the explanation of the game, court, game equipment, player equipment, officials, team composition, team positions, roster, lineups, the serve, plan, substitution, time-outs, intermission and conduct.

Volleyball is a game played by two teams of six players each with an inflated ball on a rectangular court. The teams are separated into two area by a net. One team serves the ball over the net, trying to make it land within the opponent's playing area. The receiving team attempts to return the ball over the net in such a manner that it will land within the opponent's player area. Points are scored only by the serving team.

A point shall be awarded the serving team when the opponent violates a rule. A side-out shall be declared when the serving team violates a rule. The ball is given to the serving team's opponent and no points are awarded.

A team which has scored fifteen points and is at least two points ahead is the winner. If the leading team does not have a two point advantage, play shall continue until one team has a two point advantage.

A coin toss shall be conducted between the designated player of each team at least fifteen minutes prior to the first game of the match and, if necessary, prior to the third game of a two out of three game match. The visiting designated player shall call the toss. The winner shall choose either to serve or pick the playing area. The loser of the toss shall be given the remaining choice.

The court shall be sixty feet long and thirty feet wide, measured to the outer edges of the boundary lines. The boundary lines shall be two inches and at least six feet from walls or obstacles. The end lines are the boundary lines on the short sides of the court.

The sidelines are the boundary lines on the long sides of the court. A center line, two inches wide, parallel to and equidistant from the end lines, shall separate the court into two playing areas. An attack line, two inches wide, shall be drawn across each playing area from sideline to sideline, the midpoint of which shall be ten feet from the midpoint of the center line and parallel to it.

A serving area shall be provided beyond each line. Each shall be marked by two lines, six inches long by two inches wide, beginning eight inches beyond the end line and drawn perpendicular to it. Each serving area should be a minimum of six feet in depth.

The high school rule book is over sixty pages long and goes into further detail about the game of volleyball. To order a rule book, simply call 1-800-77 NFIOA. Every varsity coach is required to attend a rules interpretation meeting at the beginning of each season. All the existing rules, plus any new ones are discussed by the Ohio High School Athletic Association representative.

SECTION III  
TECHNIQUES

Serve

Technically, the purpose of the serve is to initiate play. But it is also a means of attack. Only by serving can a team score points, so it is important to keep the ball in play while at the same time serve aggressively in an attempt to score a direct point or to force the opponents into a disadvantaged position.

The floater serve is the most common advanced type of serve in today's game. It floats through the air and may move from side to side or suddenly drop to the floor. The effectiveness of the serve depends solely on the execution.

Overhand Floater

1. Stand behind the service line with the feet slightly apart and the body's weight balanced between the feet.
2. Place the left foot forward of the right.
3. Hold the ball in left hand which is at full arm extension in front of the left shoulder. Right arm is extended to the side at shoulder height, bent at the elbow, so that the right hand is near the back of the right ear.
4. Toss the ball with the left hand to a height between two to three feet above the head. The ball should be directly above or slightly in front of the right shoulder. Concentrate on hitting the ball.
5. Contact the ball when it is in front of the body and above the head with the arm almost straight.
6. Contact the ball with the palm of the open hand with wrist remaining firm.
7. Contact center back of ball with quick action and very little follow through.

8. While watching the ball, rotate hips and shoulders slightly to the right, step toward target area.
9. Transfer weight from back foot (right) to the forward foot (left) and follow through by taking a step with the right foot.
10. Strive for low trajectory over the net.

### Topspin Serve

The topspin serve is an advanced type of serve that is hit with a great deal of speed and forward spin causing it to drop rapidly to the floor. The trajectory of the ball is easily determined, but its rapid movement makes it difficult to pass. The body position for the topspin serve is similar to that for the overhead floater, but it is the position and method of contact that creates the topspin.

1. Open hand and make contact on the lower section of the ball.
2. Snap the wrist vigorously over the ball.
3. Hit the ball upward and forward with a strong, quick wrist and forearm snap.  
(This action causes the ball to spin.)



## Pass

The pass is the fundamental skill required for effective team play and must be mastered before any other skills can be successfully utilized in the game. The purpose of the pass is to direct the ball to the team's setter who initiates the offense. This pass is medium-high looping up about two to three feet above the net and descending near the setter at the net.

The pass is used primarily to receive the serve. Serve reception is the key to team offense, and if a team cannot pass accurately it will pose no attack threat. A bad pass can result in losing a point, but even more critical, several bad passes can result in a player's losing confidence and playing poorly.

The pass is one of the techniques in the game, requiring very little movement or strength. The most important factors are confidence and good footwork and positioning prior to the pass. It is the most essential skill for proper execution of the team's offense.

### Pass

1. Stand with feet shoulder distance apart, with the right foot slightly ahead of the left.
2. Place weight on the balls and the insides of feet with very little space between heels and the floor.
3. Bend knees and turn in slightly.
4. Bend trunk forward, knees ahead of toes, shoulders ahead of knees.
5. Extend arms out from body, hands apart and down by knees.
6. Determine where the ball will go and move body behind and under the path of it, facing direction of the intended pass, hips under and open.
7. Stop and assume a balanced position and step to the target.
8. Tilt trunk slightly forward.

9. Bring arms together and straight in front of the body to form a solid platform.  
The arms never bend in the entire execution of the pass.
10. Place the heel of the hands and thumbs firmly held together. Interlace fingers to first knuckle or hands held in interlocked position.
11. Turn down elbows allowing extension and straight arms.
12. Play ball at the midline whenever, possible, contacting the ball out from the body at about knee level.
13. Pass the ball on the wide fleshy surface of the forearms, two to three inches above the wrist.
15. Watch the ball with the eyes as it contacts the arms. Do no jerk the head down.
16. Face the setter with shoulders and arms and using them to contribute to the main force in the pass. Extend the shoulders and arms forward and slightly upward with a controlled arm swing. Swing is directed from shoulders with movement observed in the shoulder joint and absent in the elbow joint.
17. Guide the ball to the setter. Follow through in the direction of the desired ball flight.
18. At the completion of the pass, the knees remain bent, body weight is forward toward the setter, arms are straight and about shoulder height.

## Set

The purpose of the set is to place the ball in a position in which your offense can attack the ball. A setter's first priority is accuracy in the height and placement to help the hitter to be consistent. A second priority is combine this accuracy with the ability to make the proper decision regarding whom to set, the type of set, and to do so quickly and deceptively.

Although the team setter has the main responsibility to captain the offense, all players must be able to set the ball high to the outside attacker. The basic overhand set is a high set, about ten feet above the net and one to two feet from the net landing near the sideline. There are many variations of sets that can be utilized in the game. These sets vary in both height and position along the net.

### Overhand Set

1. Place feet shoulder distance apart, with one foot slightly ahead of the other.
2. Place weight on the balls and insides of feet with very little space between heels and floor.
3. Bend knees and turn in slightly.
4. Bend trunk forward.
5. Hold hands comfortably at chest level.
6. Move quickly behind and under the ball with body facing the direction of intended pass (Square off to target).
7. Stop and place feet shoulder distance apart and right foot forward. Knees bent ready to push into the set.
8. Tilt head back, looking up to ball.
9. Move hands up, elbows should be high, forearms parallel to the floor.

10. Spread fingers wide apart, slightly tensed, and shaped to the form of a volleyball.
11. Tilt wrists back, thumbs down, the thumb and index finger form a triangle. The triangle determines the angle of the elbows.
12. Begin set with simultaneous extension of the legs and arms forward and upward into the ball.
13. Relax fingers, allowing the ball to contact the fleshy pads of all the fingers, but not the palms. The thumb and first finger serves to guide and stabilize the ball.
14. Flick wrists forward into the ball. Receiving the ball is like a compressed spring and releasing the ball is the extension of the spring.
15. Extend arms and hands up quickly to contact the ball above and in front of the forehead.
16. On the follow-through, entire body is extended in direction of set palms forward, fingers extended. Aim for a lengthy hand contact test control and accuracy. A soft touch is achieved by the entire body accelerating into the ball with an equal push of the arms and legs.
17. Check position by throwing the ball into the air, and with the proper body, arm, and hand position allow the ball to drop into the properly cupped fingers. Check finger, thumb and body position.

#### Front Set

1. Disguise the set direction until the last moment by maintaining a balanced posture prior to the set.
2. Use a greater knee bend and follow-through for high and distance sets.

3. Run to the ball, stop, pivot to face the target, and set. Plant feet to assume a good basic body position, bend knees, and set. Good footwork is needed to reach distant passes.

### Back Set

1. Execute the backset by using the hips to move forward upon contact with the ball.
2. Arch the back and transfer the weight to the right foot.
3. Follow through the entire body in the direction of the set with the head following the flight of the ball.

### Jump Set

The jump set is utilized for balls passed close to the net, for balls going over the net and for quickness in getting the ball to the attacker.

1. Execute primarily with the wrists and a quick extension of the arms.
2. Run to the ball, hop and jump, squaring off in the air to face the intended direction of the set.
3. Jump and contact the ball at the top of the jump.

## Spike

The spike (the attack) is the primary offensive weapon and its purpose is to score points. The attack encompasses a variety of options. The less one's height and jumping ability, the more important it is to use the attack options in order to be an effective hitter. The wider the range of attack options, the more difficult it is for opposing front and backcourt defensive players to receive the ball. The attacker must disguise the attack option as long as possible for best results. The attack option is determined by attacker capabilities, height, positioning of the block, and positioning of the set. The five most common attack options are explained below.

### Power Attack

Attacking the ball with maximum power, around, through, or off the block. On the outside set, the ball may be directed crosscourt or down the line. On the middle set, the ball may be directed to the power angle or cut back across the body to the opposite side.

### Dink/Tip

After establishing power and the defense is dug in, the ball is tapped softly over the blocker's hands. The tip is generally used on balls set close or one to two feet off the net. The hand is open and contact is made on the pads of the fingers. Follow through just enough to place the ball to the target. The tip should be learned with both the right and left hand. This is one of the easiest yet most effective attack variations.

### Soft/Off-Speed

Used to change the pace of the game and to catch the defense off guard. Placement is emphasized more than speed. Contact and follow-through is primarily a wrist snap action with the hand rolling over the top of the ball, imparting topspin. The center of the court is a vulnerable spot for this attack. The off-speed shot may be used on balls set close or those deep off the net.

## Deep Corners

Hit the corners deep crosscourt or down the line. This allows a shorter player to effectively hit around or off the top of a taller blocker. The deep hit is an effective option for balls set five to ten feet off the net, as well as for the attack by back row players. The corners are vulnerable attack spots, not only because they are difficult to cover, but because they force the player to question whether close balls are in or out. Emphasis is placed on good hand contact, wrist snap, and placement.

## The Approach

A good approach is essential for an effective vertical jump and in turn an effective attack. The most common approaches are the step-hop and the step-close. The writer has had much success with teaching the step close approach. The player begins about ten to fifteen feet from the net and waits until the ball is set high to determine its trajectory and placement. The attacker jumps into the air at an arm's distance behind the ball. The approach is quick, smooth, and vigorous and is synchronized with the arm swing for maximum lift. The movement is continuous from start to jump recovery. The greater the ability of the legs to withstand the abrupt change from forward to upward with the least significant stoppage, the greater the jumping ability. The approach pattern for right handers is at an a forty-five degree angle from the left side of the court. From the middle and right position, the approach begins from a straight on in position. It is recommended that the footwork for the approach be taught first, independently of the arms.

## Four-Step Approach

1. Begin with a medium high standing stance.
2. Take a short running step forward with the left foot for left handers and the right foot for right handers. This is a timing or reading step to help the attacker get to the proper spot at the proper time.

3. Move forward with the second step being longer than the first. The breaking step (the third step), requires landing on the heel of the foot, while the fourth step (the closing step), requires landing on the toes.
4. When making the timing step, run heel-toe (step-close), accelerating into the approach. The closing steps are made as quickly as possible after the last running step.

#### Attack-Key Points

1. Swing the arms down and back down as fast as possible, with the upper body tilted forward, prior to the last step.
2. During the last step the body is coiled like a spring, knees flexed about 120 degrees, trunk flexed forward, nonhitting shoulder toward net.
3. Immediately on the last step, momentum abruptly changes from forward to upward.
4. Lead with the hands, arms move quickly and vigorously forward and upward, keeping them close to body.
5. Arch back while ascending, shoulder rotated back.
6. Place hitting arm in a throwing position with the non-hitting hand pointing at the ball.
7. Throw hitting arm up at ball and snap; non-hitting hand pulls down.
8. Contact on palm of open hand.
9. Use a quick, compact snapping motion.



## Contact

All attack options are similar until the point of contact. The "ready position" of the body and arm prior to contact are all similar and allow for maximum deception and choice of option. For deception and quick change of direction use a quick turn with the forearm and wrist hitting across the body for less power but more deception. And for the dink/tip, the arm needs to uncoil the motion slowly just prior to contact. The hand is open and contact is made on the pads of the fingers. The hand guides the ball softly to the desired target, with very little wrist action.

## Block

The block is the first line of defense. The primary purpose of the block is to stop the ball and return it to the opponent's side for an immediate point or hideout. A secondary purpose is to force the opponent to attack the ball into an area of the court that you are prepared to defend. A short blocking team can be very effective if they form a well-positioned and solid block covering a consistent area. The backcourt defense is oriented according to the position of the block, covering the area outside the shadow of the block. If the block is poorly formed, the defense has more court to cover.

### Block

1. In the ready position; feet are parallel, about one to two feet from net, feet shoulder distance apart, weight on the insides of feet, knees slightly bent.
2. Place hands at shoulder height, elbows flexed forearms parallel to net.
3. Assume a half-squat position with back straight just prior to the jump and explode straight up with legs, pushing off with the entire foot.
4. Go up with hands and slide over top of net, penetrating over net as fast as possible (attack block). Fingertips, hands, arms, and shoulders are firm and forward.
5. Place hands in line with arms, fingers spread, hands positioned close together around the ball.
6. Turn shoulders, arms and hands towards the center of the opponent's court just prior to contact.
7. Place wrist near the net and tilt hands back, deflecting the ball upward (soft block) for players who are unable to penetrate over the net.
8. Hang and reach to sustain block as long as possible.
9. Land in a ready position, similar to the starting position and in the same spot.  
Do not float forward or to the sides.

10. Land first, then turn head to follow play. Be ready to play the short tip, a ball hit off the block, or ball dug from the backcourt.

#### Tactics/Choice of Positioning

For the single block (one-on-one block), get in a position on either side of the attacker's hitting arm. Line up on the attacker's approach to take away the most probable attack. Position hands around the side and back of ball whenever possible.

For the area block; take away (defend) an area of the court near the line or the angle attack. The backcourt defends the open area.

Footwork; for short distances or when time is available sidestep into position; shoulders remain squared off to net. Maintain the same center of gravity throughout the movement. But, for greater distances and for quickness, use the crossover step. Pivot and push off, step with lead foot, cross over with other, break momentum and square off with last step.

## Dig

The second line of defense is the dig. Once the ball passes the block the team has a second opportunity to keep the ball in play. The power dig is the basic defensive skill and is similar in technique to the underhand pass. This skill is utilized to recover the power, off-speed, and tip attack, directly or after being deflected by the block. The extension and roll is a continuation of the dig, which is used to increase the range of effectiveness.

The player moves quickly to the ball, extends out to dig ball with one or two hands, and the momentum of this quick movement carries the body into a roll and allows for a quick recovery back to the game.

### Power Dig

1. Place feet shoulder distance apart, weight on insides of feet, toes and knees turned in slightly.
2. Lean body forward for low center of gravity (lower ready position than for pass). Knees in front of toes, shoulders in front of knees.
3. Turn body into the court.
4. Hold hands comfortably out from the body, elbows bent, hands over knees, hands tight and alert for quick movement in any direction.
5. Equally distribute weight on both feet until the exact direction of the ball is determined. The ready position must allow mobility in all directions.
6. The closer the defensive player is to the attack the greater the knee bend, and the higher the hands are held in the initial ready position. It is quicker to move the hands from shoulders to knees than the reverse.

## Power Dig Tactics

1. Review capabilities and tendencies of frontcourt attackers.
2. Watch and read pass.
3. Watch and read set.
  - a. Type of set-high or low, good or bad.
  - b. Position of ball
    - (1.) Distance from net.
    - (2.) Inside or outside antennae.
    - (3.) What does the set allow the attacker to do?
4. Watch and read attacker.
  - a. Body position, angle of approach.
  - b. Body rotation in air, shoulders and arm swing.
  - c. Palm reading.
  - d. Contact point.
5. Line up with attacker belly button to belly button, shoulder to shoulder.
6. Watch and read block position and capabilities.
7. Anticipate the attack direction and move to the correct position prior to the attack.
8. On attack contact, face point of attack and lean forward ready to move diagonally forward toward the ball.
9. Reach hands out to the ball, playing ball with two hands.
10. Dig ball up, not out. Hips move forward on contact, body leans slightly back. Curl arms and scoop ball with both hands to keep the ball on your side of the net.
11. Do not swing arms on hard hit ball, controlled arm swing to target on soft hits.

## Extension and Roll

1. Move first in the direction of the ball.
2. Move forward to the ball, with foot pointed to ball.
3. Lunge, stretch, and extend out to the ball.
4. Lead foot, hips and shoulders go down to the ball and to the floor, hips lower than ball.
5. Pivot and turn out just before knee touches ground. Do not hit knee to ground.
6. Move hips near the ground, no more than one-degree angle in leg, or do not roll. Never roll if the ball is above knee. Stay on feet as long as possible.
7. Move arms at same time as last step. Drive forward to ball pushing with toes and extending out with two arms. If you cannot reach ball, put one hand down and continue to reach out and down to the ball.
8. Go straight to ball, do not pivot to get to ball.
9. Get under the ball, turn platform to setter by dropping or raising the shoulders. Play ball near inside of knee in front of body.
10. After playing the ball, continue to extend out on side and slide digging hand out. Legs remain curled.
11. Roll to back, slap nonhitting palm on floor near hips, both arm straight and extended.
12. Roll over opposite shoulder extended right arm and roll left.
13. Come up quickly in a track start position ready for defense.
14. If a run is necessary to reach the ball and the player cannot square off, play the ball in a crossover position, then step and roll.

## The Dive

1. In a kneeling position (on both knees) fall forward with hands on the mat, and lower body slowly to ground.
2. From the kneeling position, fall forward with hands, lower body toward ground, pull with flat of hands and slide forward, with body arched.
3. To demonstrate good body arch, lie face down, grab feet, and arch up pulling thighs off ground, arching body and head upward.
4. To demonstrate dive motion, do pull-through push-up.

## Offense

It is the coach's responsibility to mold a team that is stronger than the sum of its parts. To accomplish this the coach must select a system of offense that will maximize each player's strengths. There are three main offenses in volleyball which can include numerous variations. The 4-2 system, the 6-2 system and the 5-1 system.

The 4-2 system is the basic offensive system for beginning teams. It is effective because it is easy to understand and makes the most of simple plays by minimizing errors.

In the 4-2 system (four attackers, two setters), the two setters are placed opposite one another in the rotation so that one setter is always in the front row to set. The frontcourt setter always switches to the center front position immediately after the server contacts the ball. From this position sets may be directed to the right or left side attacker. The 4-2 system relies generally on high sets and individual efforts by attackers to score points.

An advanced variation of the 4-2 system is the international 4-2. This system switches the setter to the right front position to set and allows for a stronger blocker to play in the center position. Attackers may use a variety of play options, attacking the ball from various positions at the net and using high or quick sets.

### Serve Reception-Five Player

Receivers are positioned in a "w" formation with the two frontcourt receivers positioned about midcourt and toward the sidelines. The left side player is about one foot from the left sideline and the right side player is midcourt about six feet from the sideline. The front court setter assumes a sideways position near the net facing both the server and the receiving team. When the setter is at right or left front, he or she stands at the net near the sideline and switches to the center front position immediately as the ball is contacted on the serve. When the setter is right front, the center front receiver assumes the left side receiving position.



Caution must be taken not to overlap with the corresponding player directly in front or behind or to the sides. The right and left backcourt receivers are positioned about four feet from the endline and to the inside of the frontcourt receivers.

The center back player is forward, forming the point on the "w". Immediately as the ball is contacted on the serve, the setter moves to the setting spot and faces the left front attacker. The setter then makes a verbal call, such as "pass here," or "right here" to give the receivers an additional reminder to pass to the setter. As the serve crosses the net, one receiver calls "mine" while the other player turn to face the receiver, ready to help out in case of an errant pass. Any ball that is near the line should be called "in" or "out" by the players nearest the ball. This allows the receiver to concentrate on making the perfect pass. There should be no "yours" call. All receivers must make an attempt to get behind the serve passing the ball at the body midline. The court is small and well covered and it is generally not necessary to reach to the side to play a ball.

#### Serve Reception-Five Player

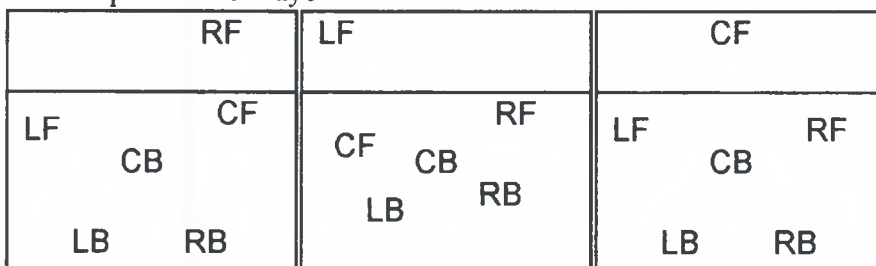

#### Covering the Hitter

When your team attacks the ball, teammates form a cover behind the attacker to recover the ball if it is successfully blocked back by the opponents to your side of the net. It is a general rule to assume that the ball will be blocked back and to make it a habit to cover the attacker. The setter, the center back player, and the player directly behind the attacker form a semi-circle around the attacker. This is the close cover position about four feet from the attacker. A deep cover is formed by the nonattacking front row player, who

is positioned near the ten-foot line, and the backcourt player diagonally opposite the attacker, who covers the backcourt.

The body position for the cover is a low defensive position. Focus on the hands of the opponent's blockers. Do not look at the attacker or the ball as it will cause a delay of motion. Drive out and forward with the arms to meet the returned ball.

#### Covering the Hitter

|    |    |    |    |    |    |    |    |    |
|----|----|----|----|----|----|----|----|----|
| LF | CF | RF | LF | CF | RF | LF | CF | RF |
| LB | CB | RB | LB | CB | RB | LB | CB | RB |

#### 6-2 System

The 6-2 system (six attackers, two setter/attackers) is an advanced system utilizing all players as attackers and two players specifically as setters. The two setters are placed opposite one another in the rotation so that one setter is in the front row and one is in the back. Now the back row setter has primary responsibility to set and does so by penetrating to the front row slightly off center to the right and sets three front row attackers. The front row setter now functions as an attacker. This system, allows for a greater variety of set and play combinations, creating more difficulty for opponents to anticipate and defend. This system relies on the setter and all front court attackers to make it easier to score.

The 6-2 system is excellent for experienced players with advanced skills. The setters must be able to set a variety of play combinations and do it deceptively so the defense will not know who will attack the ball and from what position this attack will be made. All attackers must pose a threat, and, most fundamentally, the pass must be accurate to allow all play options to occur.

### Serve Reception-Five Player

All frontcourt players back up to a midcourt position with center front slightly to the left of the center position and a few steps ahead of right and left front. The backcourt setter stands behind her corresponding front row player with the remaining two backcourt receivers splitting the backcourt territory about four feet from the endline. The "W" formation is formed. The setter releases immediately as the serve is contacted to a position near the net and to the right of the center front position. Again, it is important for the setter to provide both a visual and a verbal target for the receiver to pass to.

### Serve Reception-Five Player

|    |    |    |    |    |    |    |    |
|----|----|----|----|----|----|----|----|
|    |    |    |    |    |    |    |    |
| LF | CF | RF |    | LF | CF | RF | LF |
|    |    | RB | LB | CB |    |    | LB |
| LB | CB |    | LB | RB |    | CB | RB |

### Serve Reception-Four Player

In the four-player reception pattern the backcourt setter and her corresponding front row player move up to a position near the net. Neither player is responsible for receiving the serve. The remaining receivers form a "u" with the frontcourt players positioned about midcourt toward the right and left sidelines and the backcourt receivers splitting the backcourt area about six feet from the endline, formalizing the bottom of the "u". The formation allows easy transition for the setter and attackers to offense, and less confusion as to who will receive the ball.

### Serve Reception-Four Player

|          |          |          |          |
|----------|----------|----------|----------|
|          | RF<br>RB | LF<br>LB | CF<br>CB |
| LF<br>LB | CF<br>CB | RF<br>RB | LF<br>LB |
|          |          | CF<br>CB | RF<br>RB |

### Covering the Hitter

The cover for high sets to the right and left sides is basically the same as for the 4-2. The close cover is formed by the setter and player directly behind the attacker. The third player to fill in the close cover is now center front rather than center back as in the 4-2. This occurs because in the 6-2, when the setter releases to set the front row attackers, there are four players, in the front row and two remaining in the back. The back row players divide the court for the cover, one playing on the right and one playing on the left.

### Covering the Hitter

|          |          |          |          |
|----------|----------|----------|----------|
|          | CF<br>RF | LF<br>CF | CF<br>RF |
| LF<br>LB | RB<br>CB | RB<br>CB | LF<br>LB |
|          |          | RB<br>RF | CF<br>RF |

### 5-1 System

The five-one system (five attackers, one setter) is a combination of the 4-2 and 6-2 systems, with one setter who sets in every position. When the setter is in the front row the international 4-2 system is in effect, and when the setter is in the back row, the 6-2 system is used. This system allows for greater consistency in that attackers have only one setter to adjust to, one player calling the plays and one leader on the court. The setter must be

an experienced player with advanced skills to successfully handle this physically and mentally demanding task. The lineup should place the best attacker to the left of the setter so this player is in the front with one rather than two other attackers, since the best attackers receive the majority of sets.

## Defense

The primary objective of the defense is to block the ball back directly or to play the ball up so a successful transition from defense to offense can be made. Blockers and diggers must read the attack possibilities and move as a team to cover the court. Each player has a movement responsibility in relationship to the rest of the team. This responsibility involves both playing the ball and supportive movement without the ball. The key to good team defense is combining good individual defensive skills with good team defensive flow.

The selection of a system of defense depends upon the blocking and digging skills of the team and the level and style of the opponent's play. The first decision that must be made is whether to defend with one or two blockers. Consideration must be given to the strength of the opponent's attackers as well as the team's blocking abilities. When players are not tall enough to block effectively it is best to utilize the one-blocker option with the remaining player covering the soft attack. In a one-blocker option, the player-back system is recommended.

When the double-block option is utilized, a choice of the player-up or the player-back system, or a combination of these system needs to be made. The player-back system is a "deep system", with all receivers playing deep, but have responsibility for both the short and deep attack. Receivers must learn to read the tip and have good forward movement to coverage by one "up" player while the remaining receivers have responsibility for deep coverage. It is especially advantageous for strong blocking teams that cover such a large area at the net that they force the attacker to tip or hit into a small backcourt area defended by receivers. If the block is not strong, the backcourt receivers must cover a considerably greater amount of court.

Coaches must understand that no defensive system is perfect. Players must be flexible, playing an area and not just a spot. Players must learn to read and anticipate the attack options according to the attacker's capabilities and tendencies, as well as the set position.

### Player-Back Defense

Blockers stand in a ready position about one foot from the net and look across at their respective attackers. Left and right back receivers are positioned straddling the ten-foot line near the sideline, and is repositioned near the sideline about eight feet in front of the endline. Starting defensive positions are assumed; 1) when the team is serving with the server taking a defensive position immediately after the serve, 2) in a rally each time the ball crosses the net to the opponent's side. If players are switching to specific defensive positions, all players take a starting position so the switch can be made quickly and easily.

### Player-Back Defense

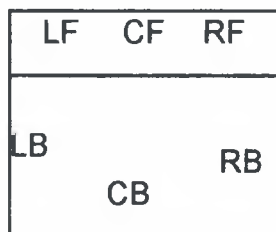

### Two Blockers

The double block is used to defend against the strong attack. To form the double block on the right or left side the end blocker is positioned for a one-on-one block and the center blocker moves to the end blocker. The nonblocker is responsible for the sharp crosscourt attack and the soft tip. On an inside set (and/or when the block is positioned inside), because of the difficulty in hitting the sharp angle attack, the nonblocker may automatically release to a position under the block to cover for the tip. The backcourt

player at the power angle moves up along the sideline several step behind the frontcourt receiver (staggered positions), playing a slightly deeper power angle. Front and backcourt receivers must be positioned off the shoulder of the center blocker, and must clearly see the attacker.

The backcourt receiver on the line directly behind the attacker has responsibility for the attack hit down the line and for the tip. If the receiver sees the attacker clearly around the block the receiver remains deep. If the attacker is covered by the block or when the ball is set wide outside the antennae, the receiver releases to cover the tip.

The center back receiver is positioned deep near the endline in the shadow of the block covering the deep ball over or off the top of the block. If there is hole in the block the center back player must move in to defend this area.

The double block for the high center attack utilized the center blocker and either the right or left side end blocker. Which end blocker is used is determined by 1) the position of the set, that is, nearness to the right or left side, 2) directional tendencies of the attacker, and 3) preferences of coach to protect a specific area of the backcourt. The center blocker is positioned for one-on-one block and the end blocker moves to the center blocker. The nonblocker moves behind the block to cover for the tip. The two backcourt receivers defend against the sharp angle and cutback attack, while the center back stays deep midcourt, reading the attack direction.

Two Blockers

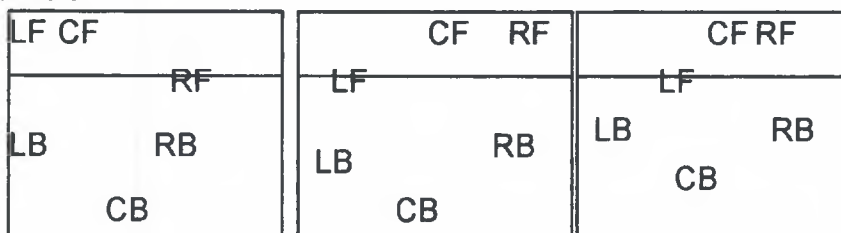



## Player-Up Defense

Blockers stand about one foot from the net and look across at their respective attackers. Left and right back receivers are positioned about five feet from the sideline and eight feet forward of the endline.

## Player-Up Defense

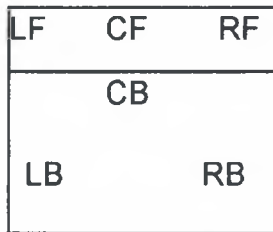

## Center Back-Up Defense

The "up" player (backcourt setter in the 6-2 system and center back player in the 4-2) is positioned midcourt at the ten-foot line. As the double block forms, the "up" player moves behind the block to cover the tip or short ball hit off the block. The nonblocking front row player moves behind the ten-foot line and near the sideline to defend the power angle. The two remaining backcourt players must divide the responsibility of backcourt coverage and read the attack to cover those areas most likely to be attacked.

## Center Back-Up Defense

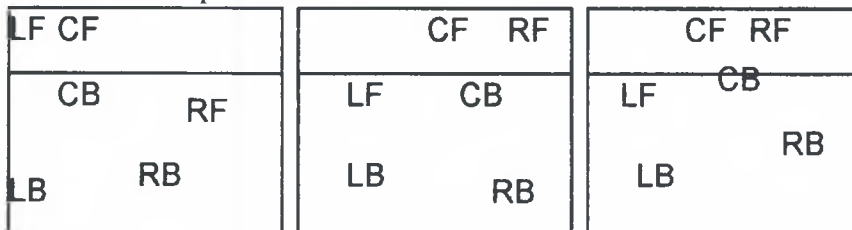

### No Block/Down Ball

The no block call is made when it is felt that the free ball is a very important hit with great speed or downward motion and can be successfully played with the dig. The call is generally made by the end blockers, as they have the most time to make this judgment. A no block is called on a weak attacker or on a poor set that does not allow a good attack. when the no block call is made, blockers quickly back off the net about five feet and assume a low forward lean defensive position with responsibility for the soft attack and tip. Backcourt players remain in their basic defensive positions, reading and adjusting as necessary.

### No Block/Down Ball

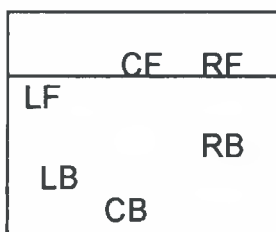

### Free Ball

A free ball is called when the offensive team must underhand or overhand pass the ball over the net. When the free ball call is made, players move quickly from their defensive position to the five player serve reception position to prepare for the attack. The free ball is very important to winning volleyball matches as it is an opportunity to score off an easy play. This not only scores points but is a psychological advantage forcing the opponent to attempt more difficult plays. When you must give a free ball to the opponent, make it as difficult as possible for them by passing the ball to a weak position on the court or to a weak passer. (Diagram indicates setter is in the right back position.)

# Free Ball

|    |    |    |
|----|----|----|
| RB |    |    |
| LF | CF | RF |
| LB | CB |    |

## SECTION IV

### PRE-SEASON

The responsibilities of a varsity volleyball coach begin months before the actual opening day of practice. These various responsibilities are considered pre-season activities.

First, the coach is required by the Ohio High School Athletic Association (OHSAA) to attend a six hour sports medicine clinic before the beginning of the season. After the first year, a three hour clinic needs to be completed prior to each year of coaching. These clinics are held at numerous locations throughout the state and are usually sponsored by hospitals that specialize in sports related injuries.

A varsity coach must also attend a rules interpretation meeting each year. A representative from the OHSAA introduces all the new rules and explains the existing ones. If the varsity coach does not attend (or a representative from the school), then the team is not permitted to participate in any tournament games. Information about the time, date and location of these meetings is sent in the mail along with the rule books to each school's athletic director.

The coach also has an opportunity to belong to and attend meetings in a district coaches' association. The state of Ohio is divided into sixteen districts. Each district association provides an opportunity for area players to receive district team honors and play in its all-star match at the end of the season.

Further, the coach can become active in the state volleyball coaches' association which offers state team rankings and individual player all-state honors. The OHSVCA also sponsors a coaches' clinic each summer in which various college coaches lecture and demonstrate their various techniques and ideas.

Equipment inventory is another duty that should be performed during the pre-season. New equipment can be ordered while the old is repaired or thrown out. A copy of all the equipment should be kept on file with the athletic director for all teams.

Reading current literature, watching game videos and technique videos are also a must for pre-season. Learning new information, which increases volleyball knowledge can bring new ideas to the program.

A player/parent handbook is a unique way of compiling important information. It can include motivational sayings, an introductory letter, a game schedule, a calendar, directions to away games, a map of schools, team rules, nutrition tips, sample pre-game meals, skill explanations, eligibility requirements, insurance waivers, emergency medical forms, a physical card, a player contract and a parent contract. This handbook should be passed out at the first practice.

Thoroughly completing each of these pre-season activities will give the coach a headstart even before she begins working directly with the team.

## SECTION V

### SEASON

During the season, a coach needs to be well organized with the paperwork involved for the season in addition to working with players and perfecting team strategies.

Organized practice plans are a key to successful practices during the season. Planning ideas can be written down on a practice plan sheet. This sheet includes time, name of drills, diagrams and points to stress. The coach can keep plans on file and keep them for a reference for the season and for future years.

Keeping track of important team information is essential. Coaches should print a team roster with players names, phone numbers, and records of physical cards, emergency medical forms, and insurance waivers. Another form that is essential to use is an attendance form. Having a record of each player's attendance is important for determining playing time of a player and keeping track of excused and unexcused absences.

If a coach is member of the state coaches' association, she can apply to become a poll-voter. If accepted, she then has the opportunity to vote seven times during the season on team rankings for the state. The coach needs to cut out newspaper articles to help keep track of area team records and opponents.

Every coach has the opportunity to send information to the sixty-four voting coaches each week on her team's scores, record and opponents played. This information can be distributed in any manner, although neatness and accuracy are two important factors to pay particular attention to.





If the coach minimizes the amount of time spent on the above mentioned paperwork, she would be able to spend the rest of her time fulfilling other coaching responsibilities.

## SECTION VI

### DRILLS

The following drills were taken from the OHSVCA drill book which is published yearly. The coach's association conducts a clinic each year and every coach that attends is required to submit one drill. These drills are then published and distributed at next year's clinic. The purposes of the clinic and the handbook are to help all volleyball coaches at any level, to learn and improve on their volleyball knowledge. Coaches are encouraged to share their ideas, (especially practice drills) with other coaches.

#### Symbols used throughout this drill

|   |   |   |   |
|---|---|---|---|
|      | = direction of rotation in drill or movement of players |   |   |
| (X)   | = any player  | C   | = coach   |
| (S)   | = player setting ball                                   | T   | = target  |
| (B)   | = player blocking                                       |   | = volleyball  |
| (H)   | = player spiking  | S   | = server (off court)                                  |
| (P)   | = player passing ball                                   | B   | = any one shagging balls or handing them to the coach |
|  → | = direction coach tosses ball                           |  | = ball cart   |

#### Description

These various symbols will be used to designate persons/things on the court. (X) will designate any player who may perform any skill. The other player symbols will be used only for drills in which a player in that position is to perform a specific skill

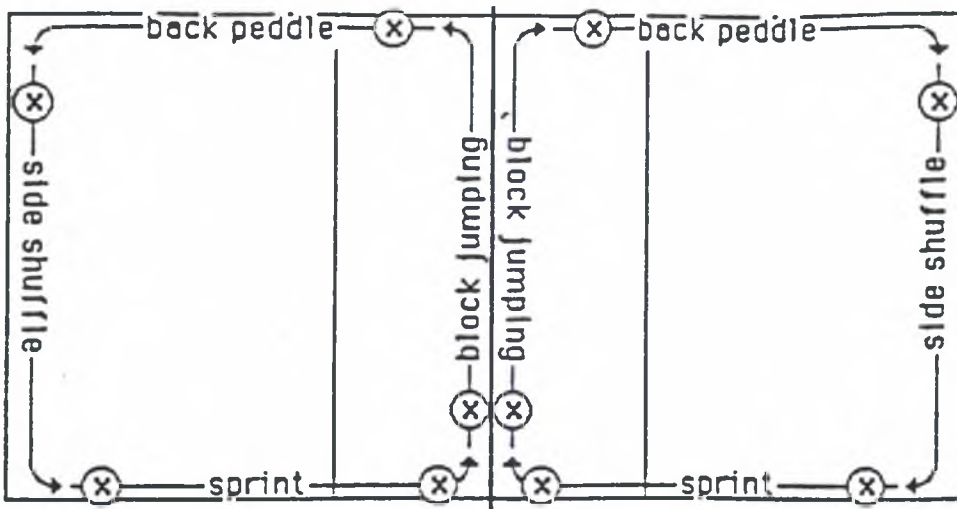

**Description** Players line up in pairs on opposite sides of net. On coach's whistle players do block jumping across the net, back pedal on the side line, side shuffle on the end line, and sprint up the side line to repeat exercise at the net.

**Drill type**  
Conditioning

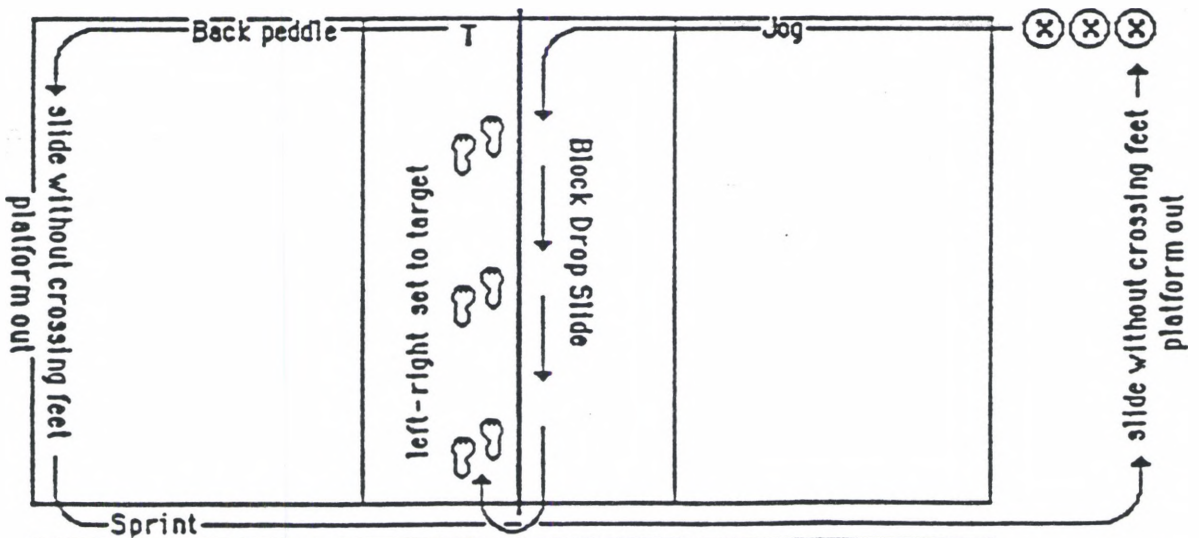

**Description** A conditioning drill I use to incorporate a combination of skills.

**Drill type**  
Conditioning



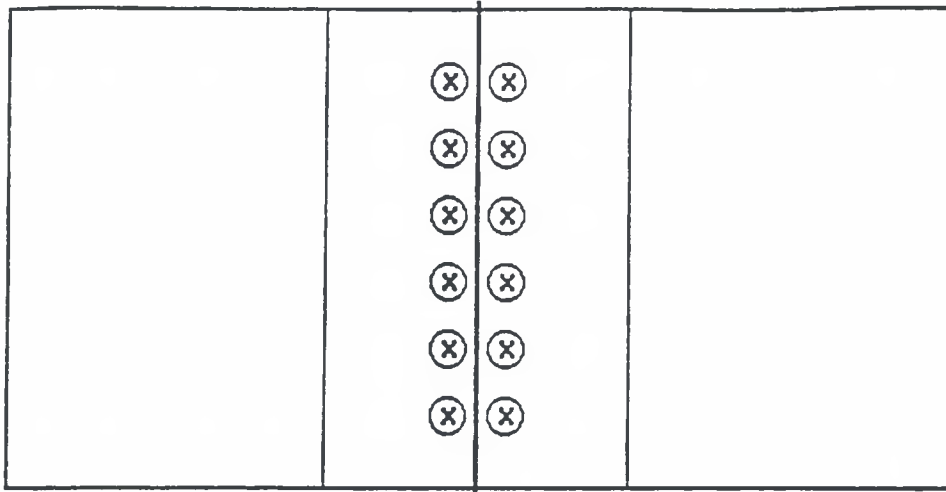

**Description** Divide into 2 teams on opposite side of the court facing each other at net. Each team huddles to decide their symbol to use at the net (rock, paper, or sissors). Back to net on the count of three show symbol. Winners chase losers back to their end line. Losers run backwards - if touched before reaching end line, player becomes part of other team. Continue until everyone is on the same side or coach decides to end drill.

**Drill type**  
Conditioning

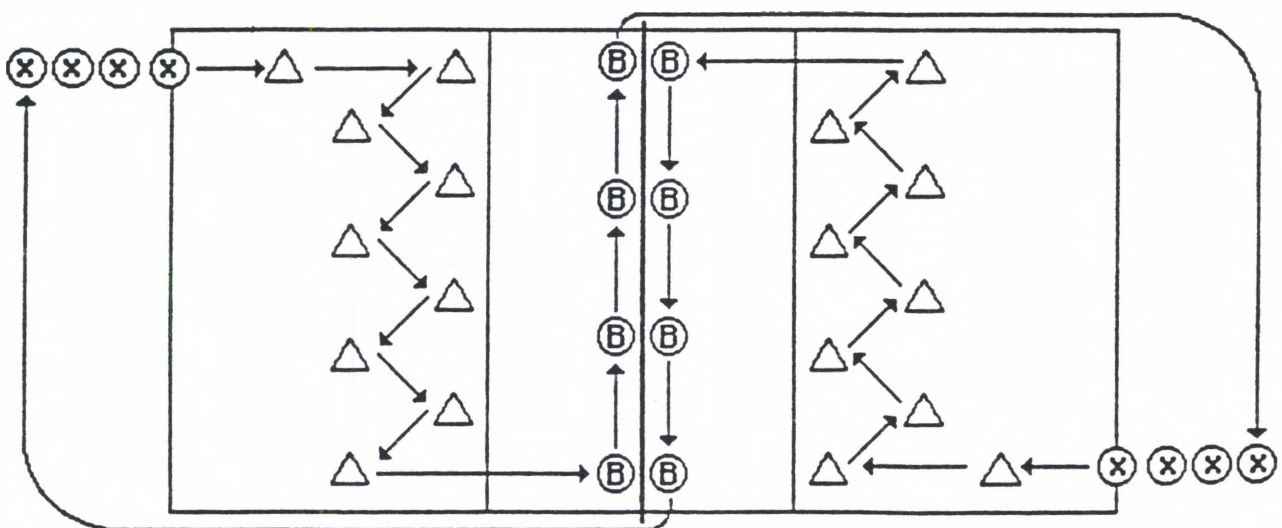

**Description** Players get in dig position and run up to cone. Hands must touch top of a 12" cone. Players drop step back to next cone. Keep facing net. When done, block across net - go to other side & repeat.

**Drill type**  
Conditioning

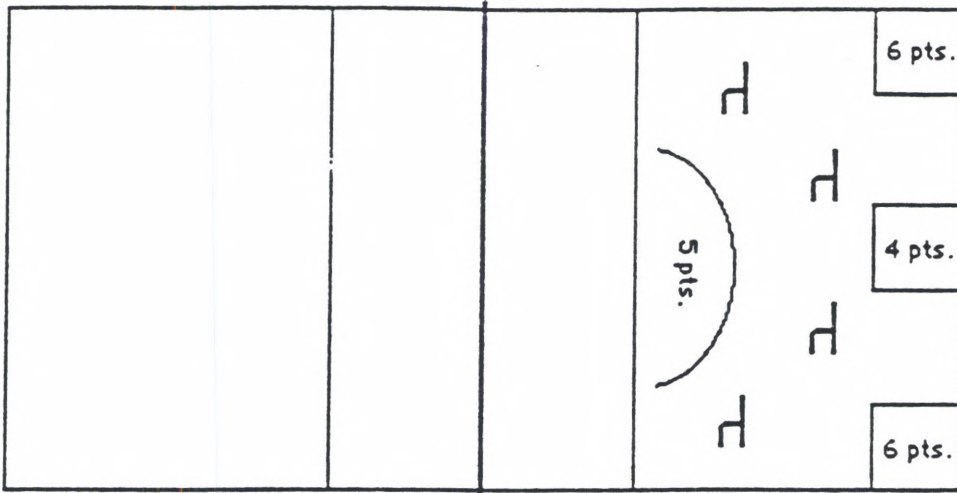

**Description**

- Serving to opposing team
- Scout opposing team to see serve reception
- Set chairs up on court to imitate opponents
- Serve to holes
- You may put points on the floor - add scores.

Drill  
Serving

SSS  
S

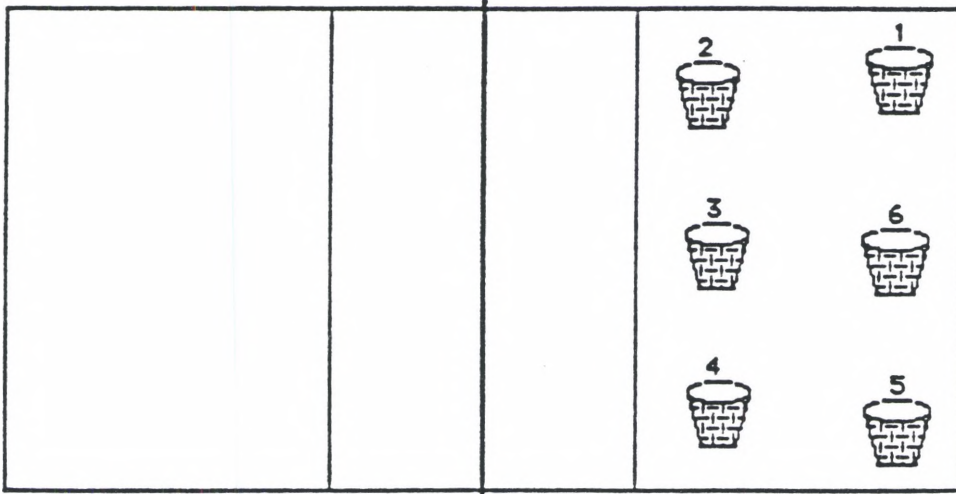

**Description** Have notes cards with #'s 1 to 6 in each bucket (or hat). Server has to pull a card and serve to that area. If successful, retain card. First player to get 6 cards wins. If unsuccessful, replace card and draw again.

Drill type  
Serving

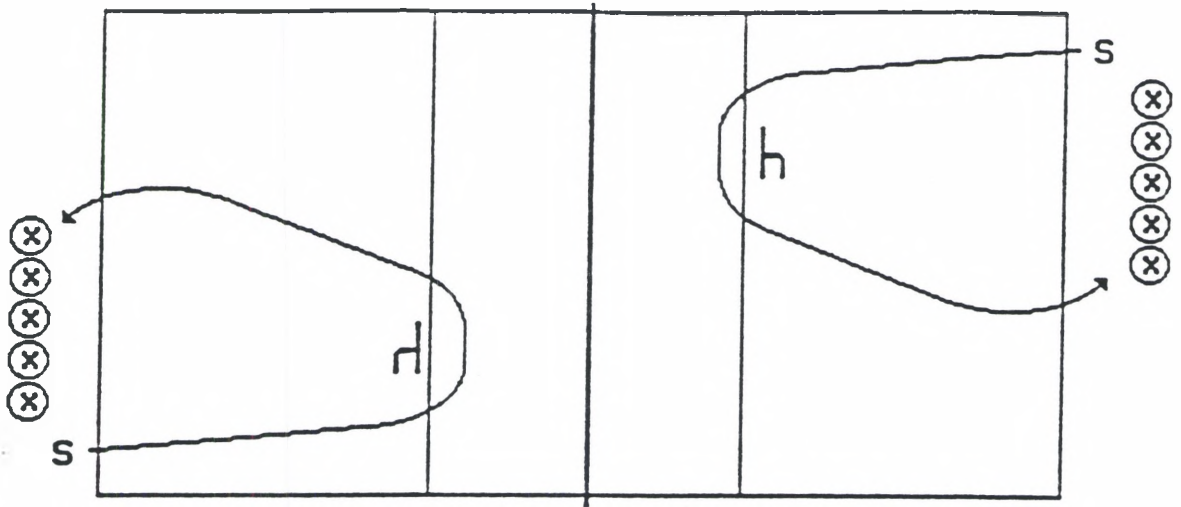

**Description** Players are divided into two teams. Each player must serve the ball, run around the chair, & get back in line before the next player can serve. If player serves it out, player must run around chair and go back to serve again until the ball is served in. The purpose of this drill is accuracy & concentration under pressure (the pressure is to get all of your team to complete their serves before the other team). You can then vary this by having serve more than one in or by serving to certain zones, etc.

**Drill type**  
Serving

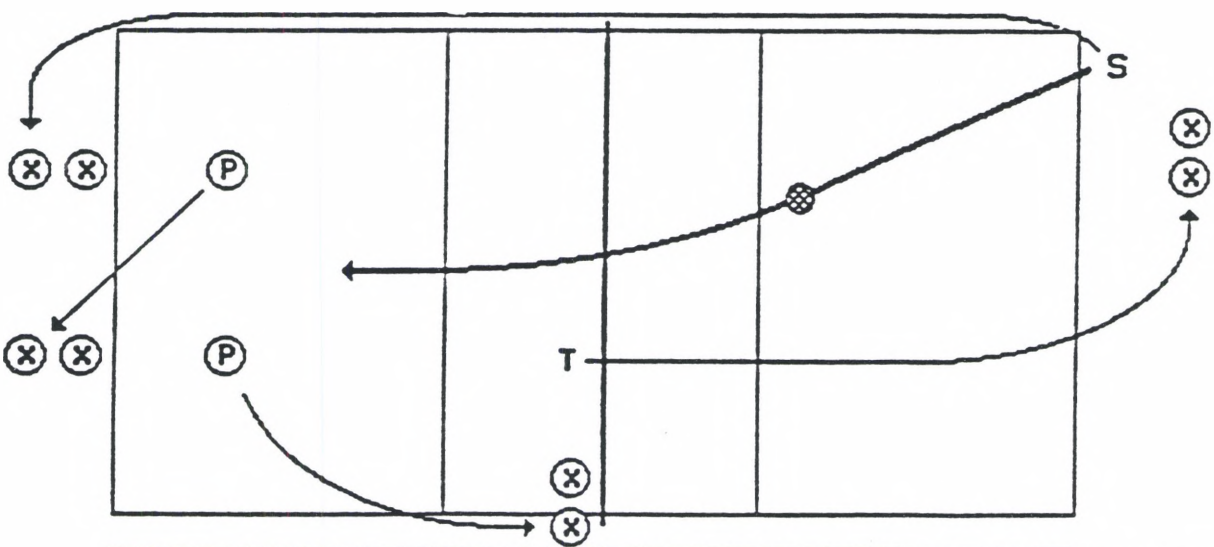

**Description** Server places it to passer -> passers to target -> target to server line. This drill can be run on both sides just have the target return to serving line on their own side of the net.

**Drill type**  
Serving

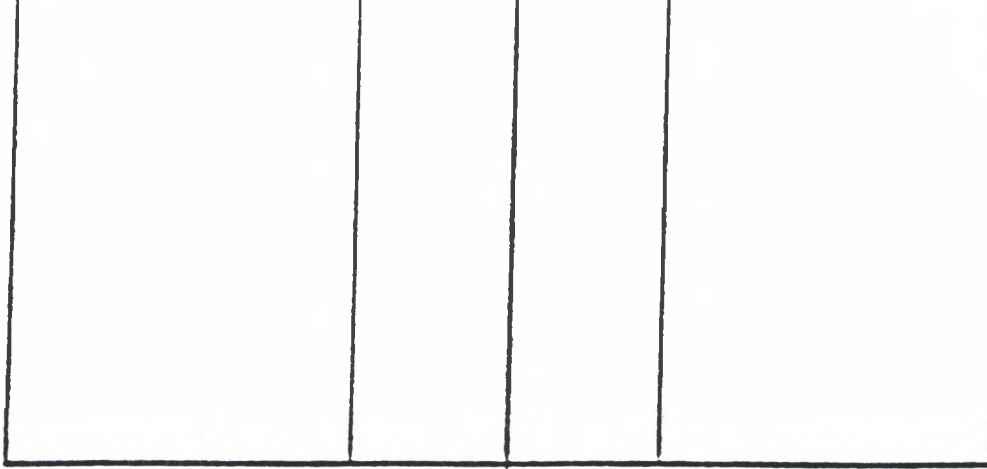

**Description** Coach or server serves cross court then line. Passer comes onto court and passes to the target and changes lines. They must call "Mine" or they have to yell "Mine" 10 times so everyone in the school can hear them. You may add setter and hitter and coverage of that hitter.

Drill type  
Serve  
Reception

SSSS

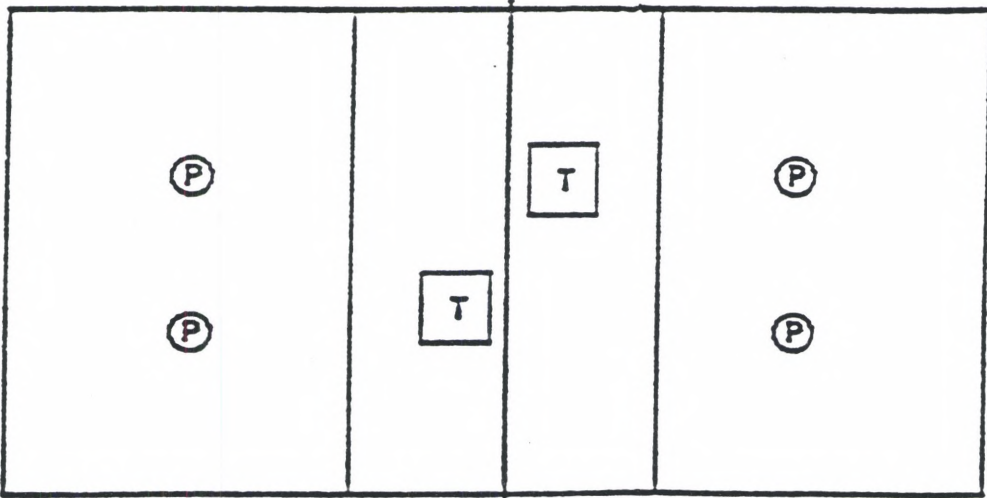

SSSS

**Description** Most players are apprehensive (esp. JV) about receiving serves. This game teaches and encourages the players to want to pass. the object is for the server to make the receiver miss. (This makes the server serve aggressively.) If the passer misses the designated target, the server takes the passers place. the object is for the passer to never leave the receiving position.

Drill type  
Serve  
Reception

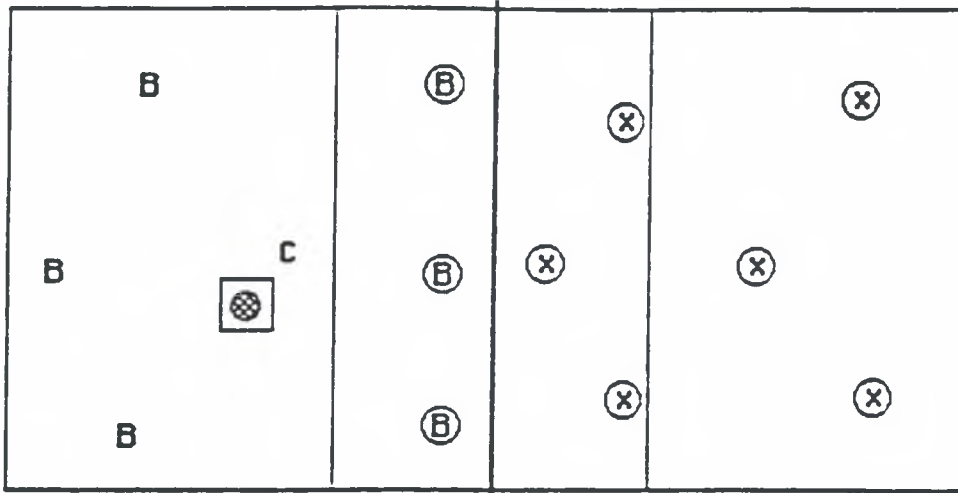

**Description** 6 players position themselves for serve reception. Coach throws ball over to players. Striking hits - the ball is passed, set, & hit back over to blockers. Ball is kept in play. At the end of play, the blockers drop back to shag balls - the front row comes under the net to block - back row of players rotate up to front row - first player in each line moves into back row - shaggers shag and then run to the end of the line, ready to rotate in.

**Drill type**  
Serve  
Reception

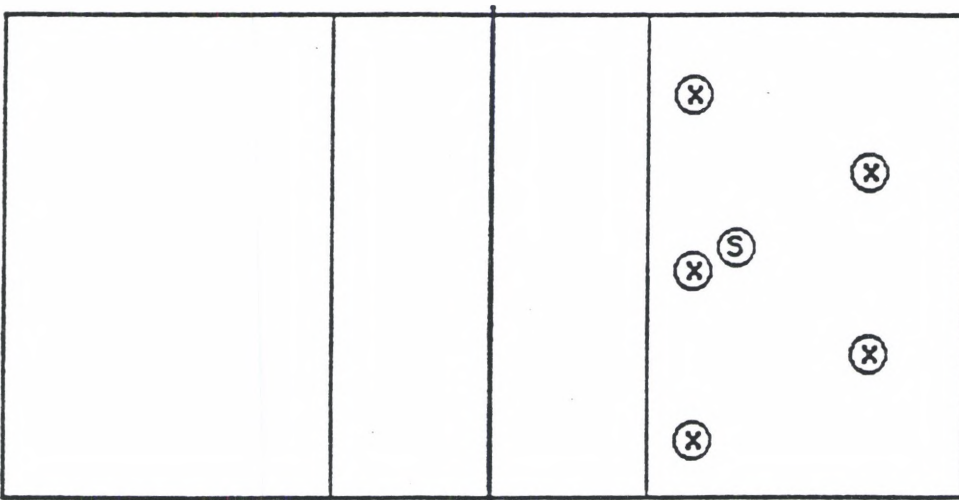

S

**Description** Blindfold Volleyball - place bed sheets over net to block view. At whistle, ball is served and receiver must make a good pass to setter. Once a good pass has been made, rotate.

**Drill type**  
Serve  
Reception

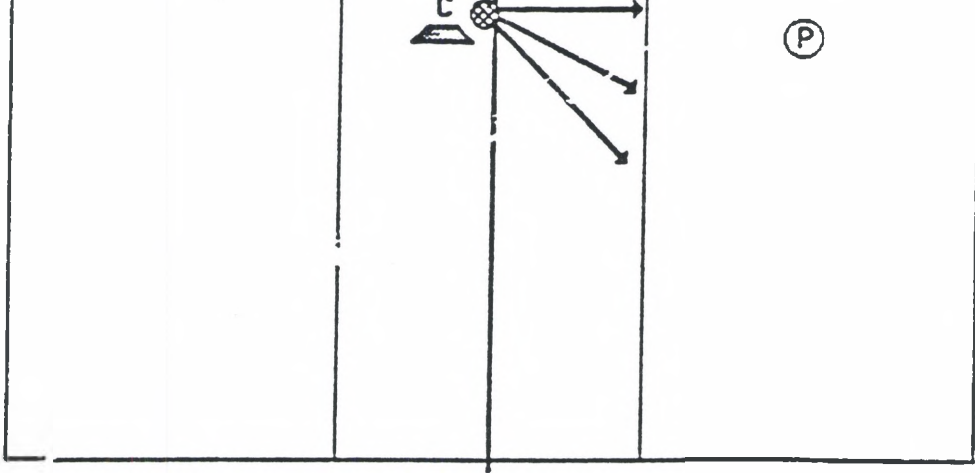

**Description** Reading the hitters - Coach stands on a platform on the other side of the net. Coach extends arm into spike position. The player will adjust court position to the coach's arm. Coach releases the ball for the player to pass. Coach should increase the ball for the player to pass. Coach should increase speed with progress of player. Coach can toss from LF, CF, or RF.

Drill type  
Passing

School Carey H.S.

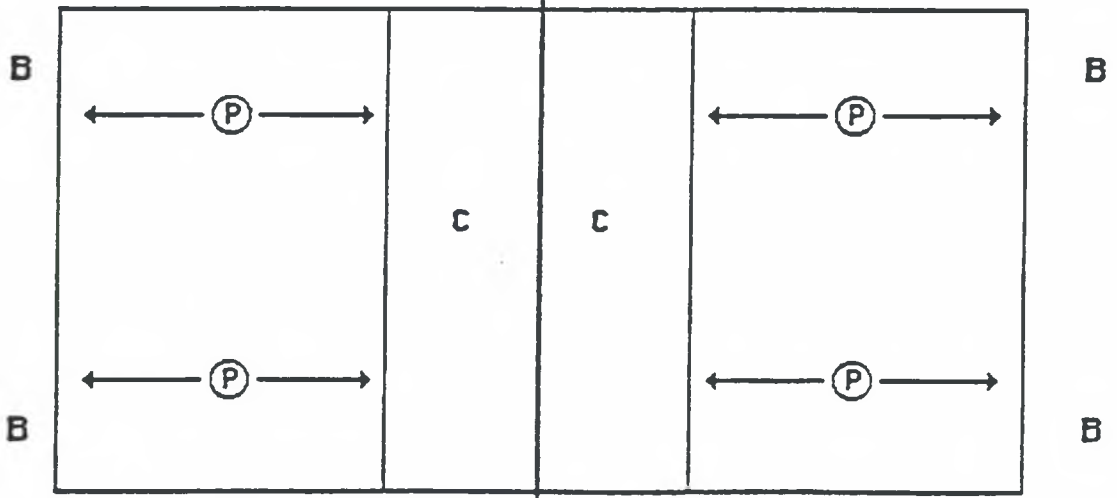

**Description** "Power Drill" -Players shuffle from ten foot to end lines while coaches hit balls at them. Touch lines and stay low.

Drill type  
Passing

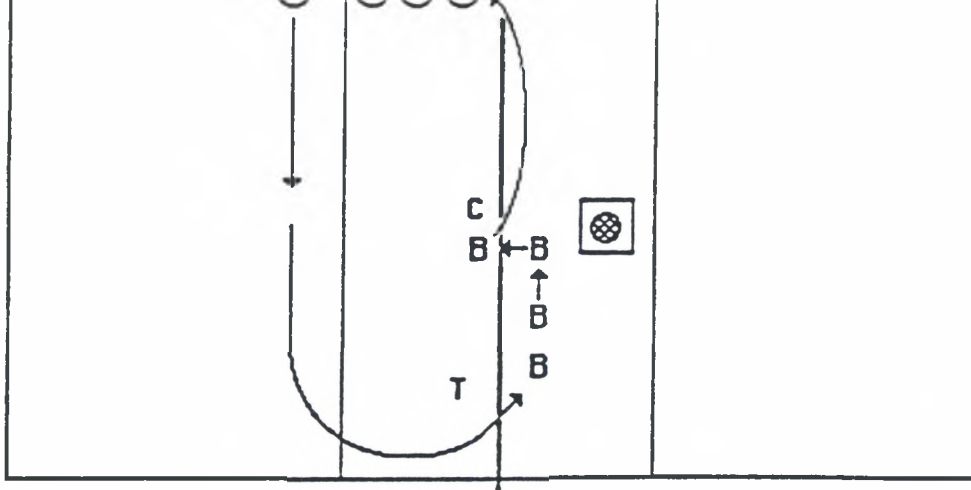

**Description** This drill works on "run throughs." Passer starts off the court, on coach's "slap" of ball, player breaks onto court as ball is tossed low & towards middle of court. Passer makes pass on run to target and goes to end of shagging line. Coach varies tosses to challenge each player. Footwork emphasis is on giant step with right foot as first movement onto court, this is followed by cross over step with left leg.

**Drill type**  
Passing

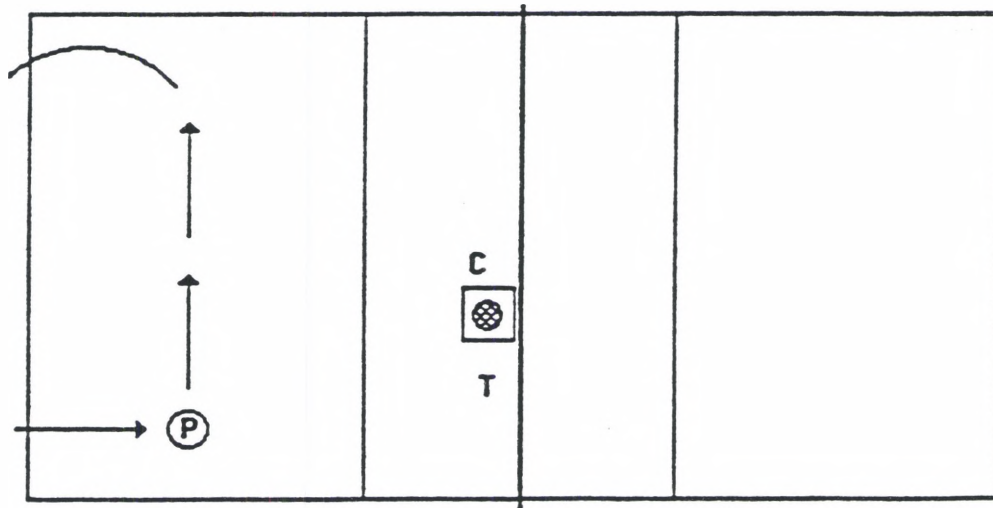

**Description** One player steps on court, will receive 3 tosses from coach. The player must pass to target & rotate to ext position. Any bad passes are shagged by passer and returned to ball cart. Increase variations of tosses to the passers.

**Drill type**  
Passing

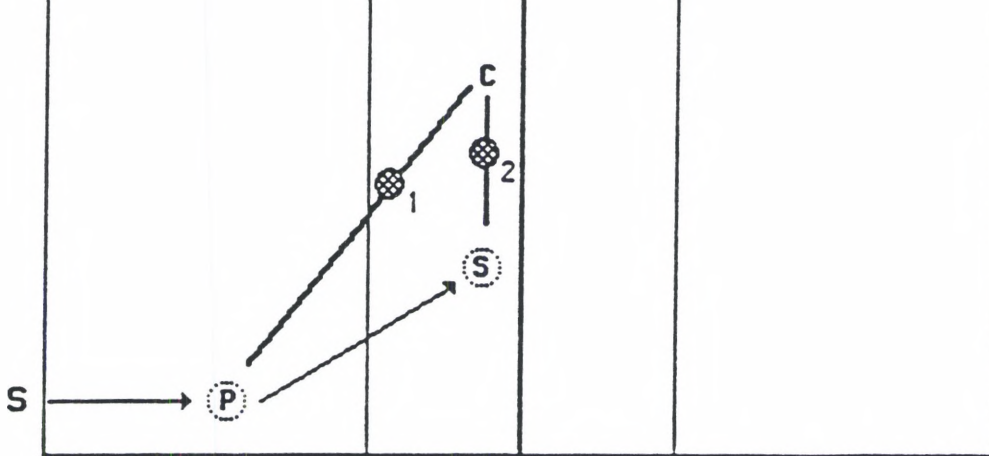

**Description** Setter transition

- 1) Setter serves
- 2) Setter comes onto court to dig a hit from coach
- 3) Coach tosses ball for setter to set to target - move target around Outside, Middle, Offhand

**Drill type**  
Setting

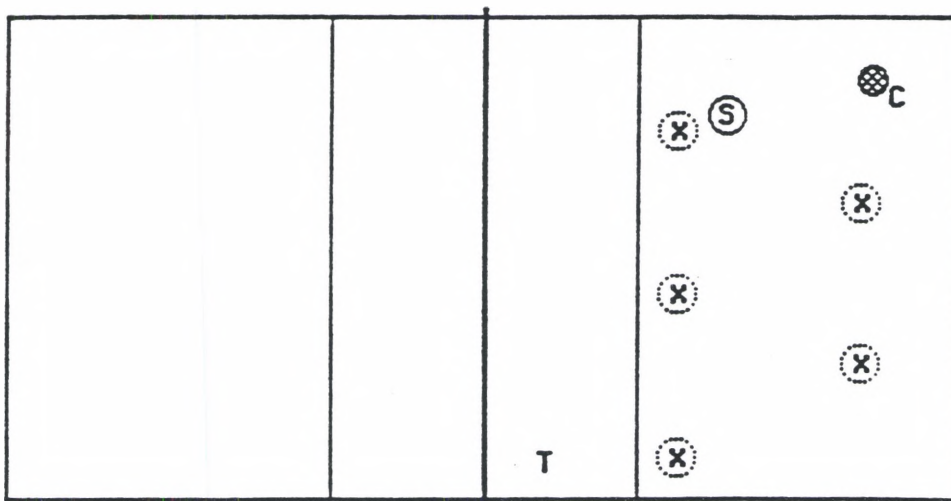

**Description** Setter releases out of positions and coach bounces ball onto ground and setter moves to position to set ball to designated target. Bounce ball randomly and move around court bouncing ball from different angles.

**Drill type**  
Setting



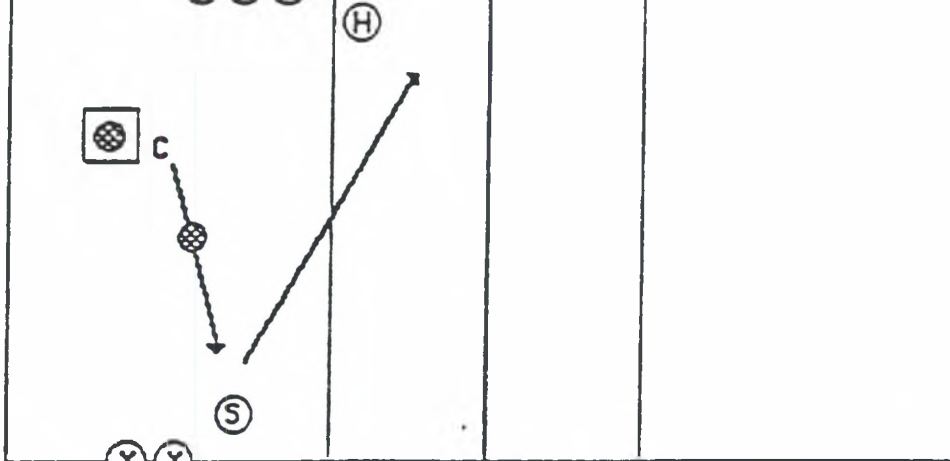

**Description**

- 1) Coach bounces ball on the floor.
- 2) Setter tries to set the hitters across the court.
- 3) Good practice setting from a distance and hitting a the ball set passed the 10' line.

**Drill type**  
**Setting**

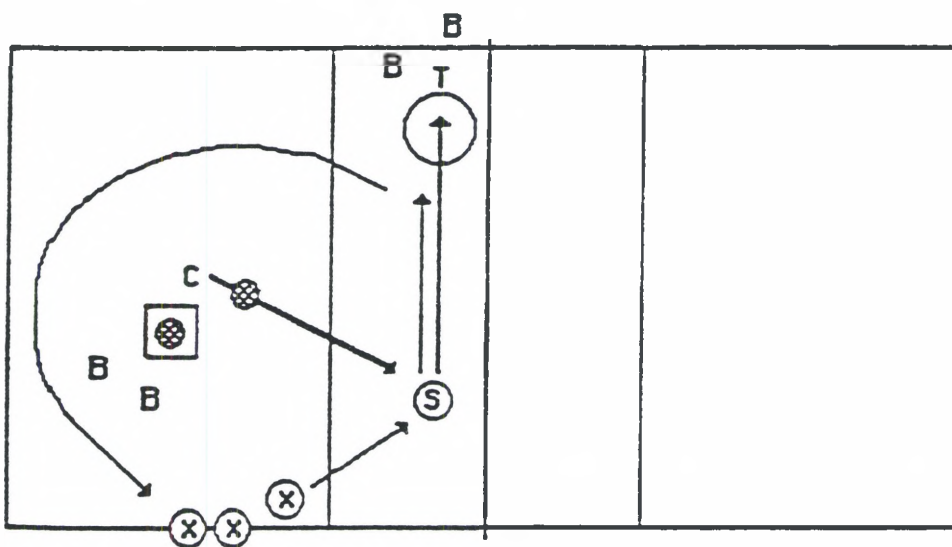

**Description** Coach tosses ball to setter, who has released from right defensive position. Setter sets high outside ball to target person who is holding a hoola hoop. Setter goes to cover then runs back to line. Adjust target person with hoop to middle and right front.

**Drill type**  
**Setting**

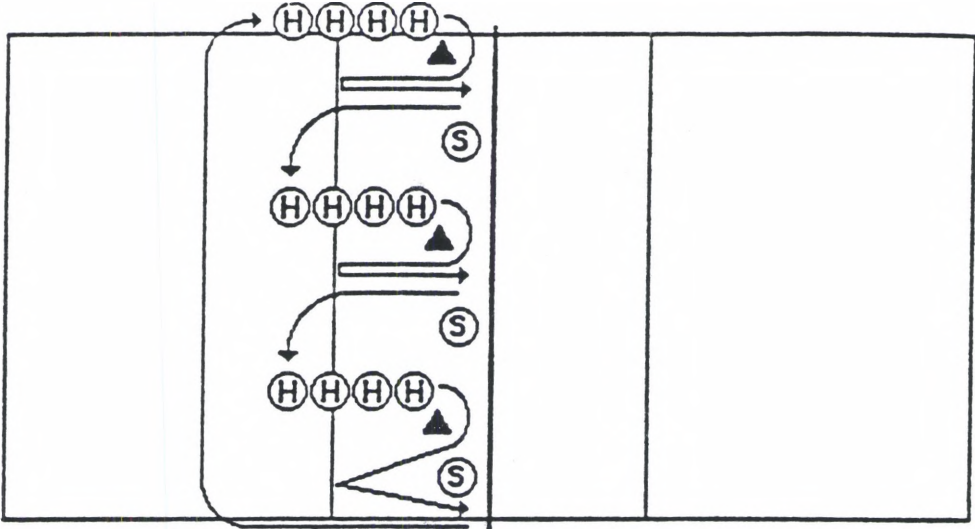

**Description** First hitter in line uses footwork to move to 10' line - then approaches as setter sets ball. Hitters have to maneuver around an obstacle as they prepare to approach for the spike. Then move to next hitting line. Setter may toss to self or set off a toss.

Drill type  
Spiking

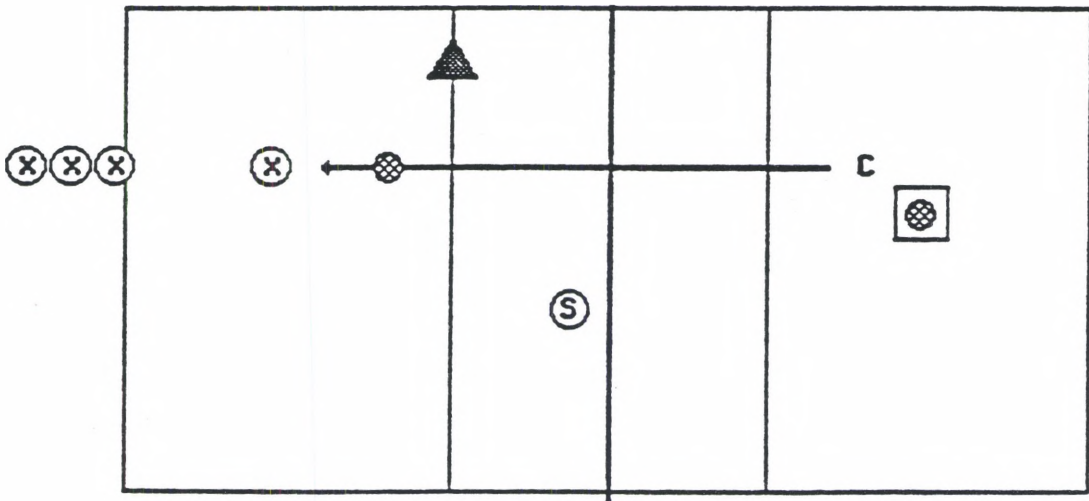

**Description** Coach tosses ball to player, player passes to setter, passer becomes a hitter, runs around cone/chair, setter sets to hitter, hitter hits. Hitter shags as next person comes on to court to start drill.

Drill type  
Spiking

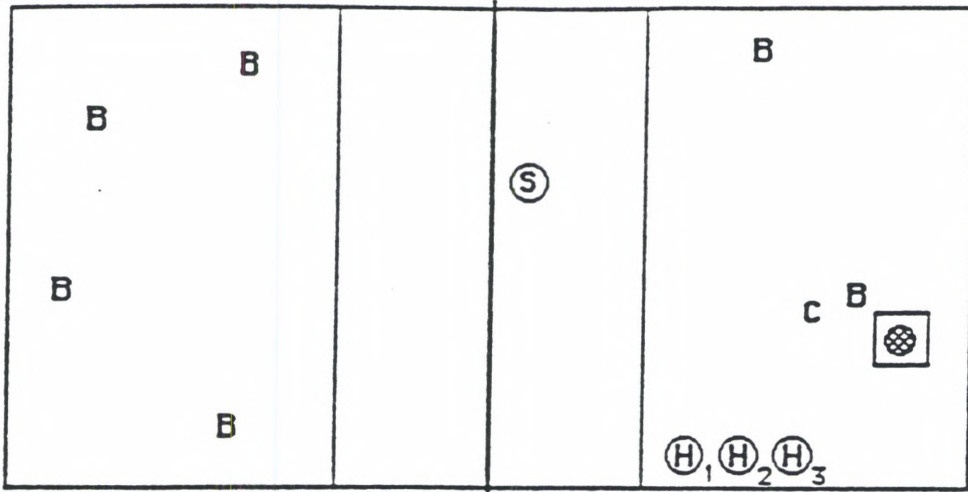

**Description** Coach tosses balls to setter who sets to H1, then H2, and H3. Continue to set to H1, H2, & H3 again and again until all 3 hitters get 10 good hits. Rotate in 3 new hitters

**Drill type**  
Spiking

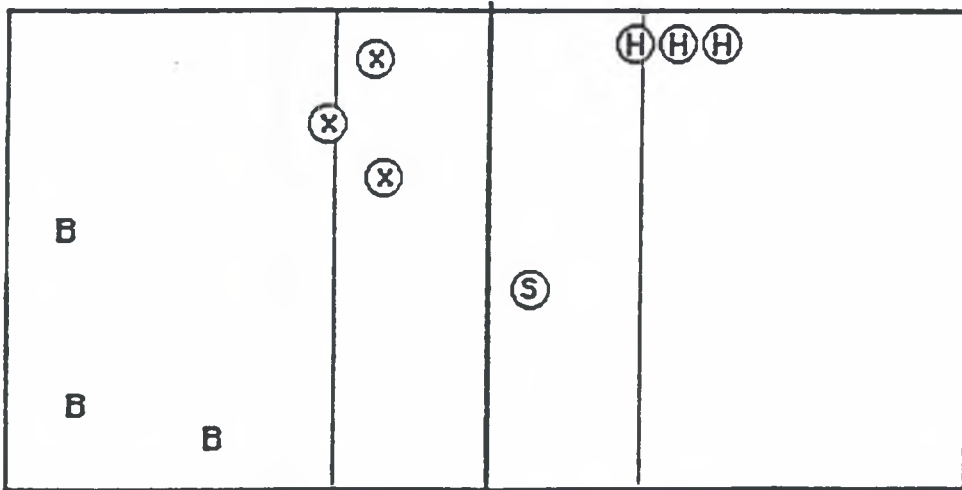

**Description** Any player tosses the ball to the 10' line. Hitter passes ball to setter. Setter sets ball to hitter. Hitter hits (spikes ball). To intensify drill toss five to ten ball immediately after the other, forcing hitter to pass, hit and return to position quickly. Shaggers play back court to return balls to tosser. \* To make more difficult, have tosser block the hit. Change setter when needed for rest.

**Drill type**  
Spiking

Hitters to shaggers, shaggers to tossers, tossers to hitters

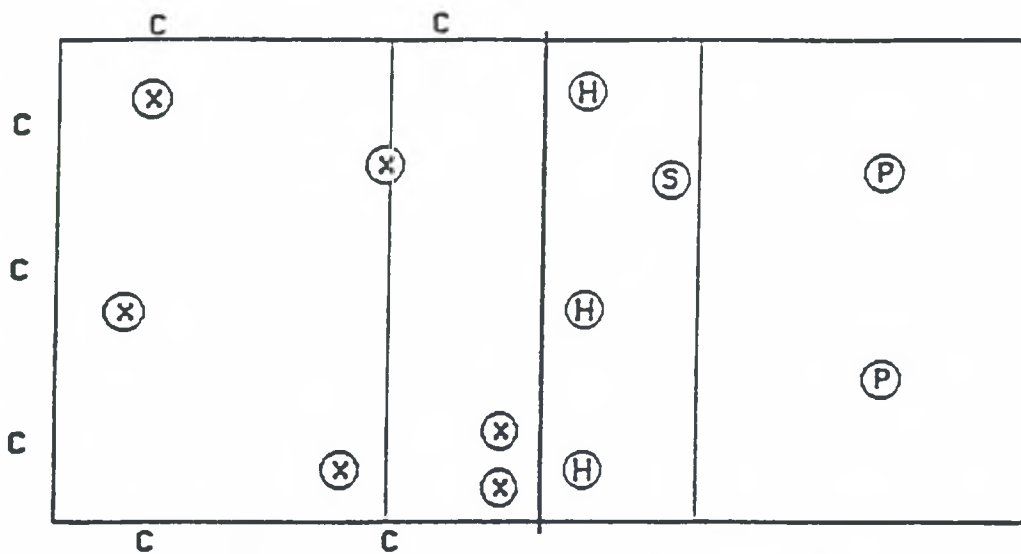

**Description** Coach tosses ball to either P. P passes to setter. Setter sets to any of three hitters. When the ball comes over the net, the defense adjusts and gets into 2 blocker defense + coverage - defense plays ball out and then play stops. Coach tosses another ball over. Offense send a free ball over - either on 1st, 2nd, or 3rd hit. Defense gets into freeball position and plays ball out. Coach tosses ball, repeat X times and then have defense rotate. Coach should stand in several different positions.

**Drill type**  
Blocking

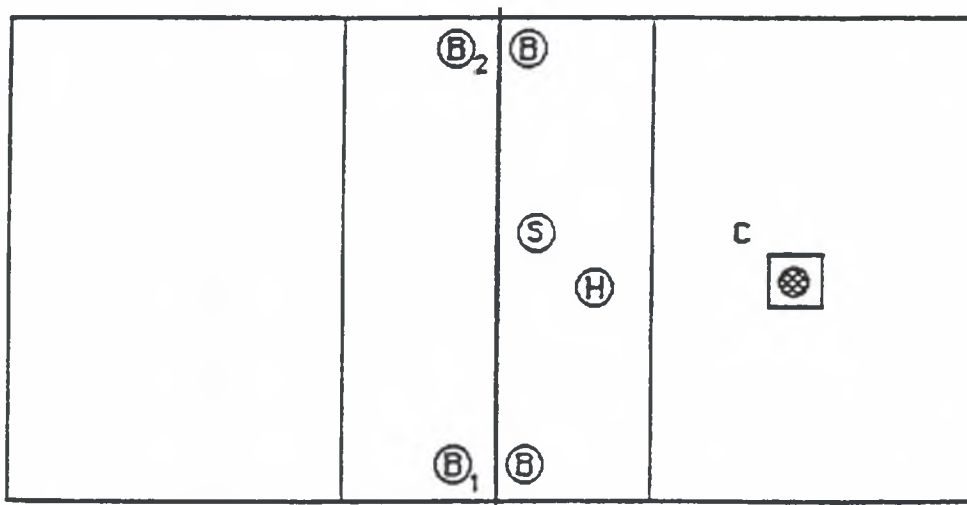

**Description** Middle Hitter Drill  
 1) Hit middle from coach toss to setter  
 2) Block left ball hit by blocker #1  
 3) Repeat #1  
 4) Block right ball hit by blocker #2  
 5) Repeat #1

**Goal:** 3-5 hits middle + 3-5 blocks left & right

**Drill type**  
Blocking

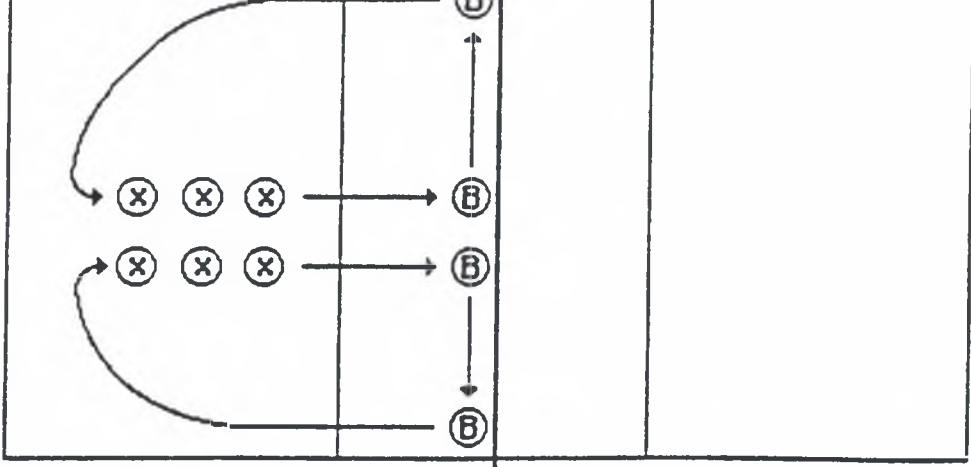

**Description** X players run up together and block at net. After blocking middle they then go to outside and block with that person. The outside person then goes to end of the line and the other person stays to block with the next person coming up.

**Drill type**  
Blocking

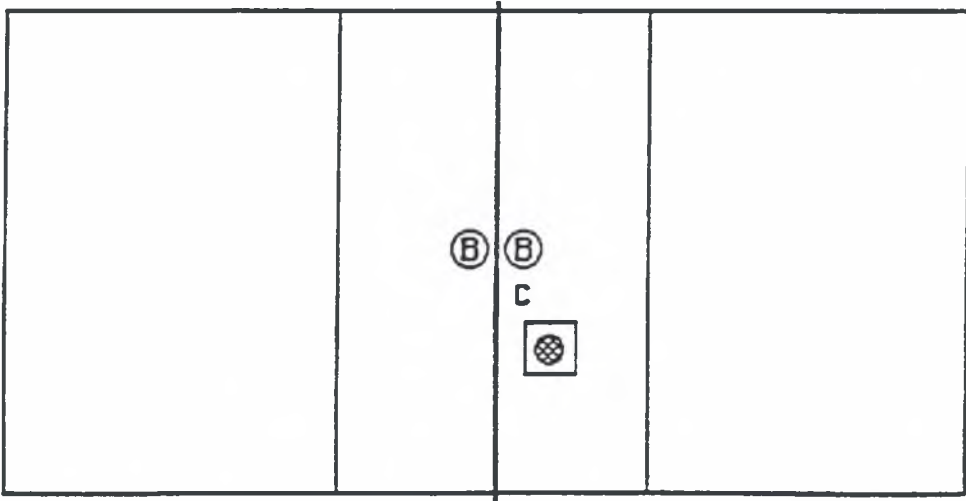

**Description** Jousting - (find a partner about the same size) Coach tosses ball at the top of the net. The blockers try to push it down on the other blocker's side of the court. Both go up at the same time trying to "out muscle" each other.

**Drill type**  
Blocking

P P P P



P P P P

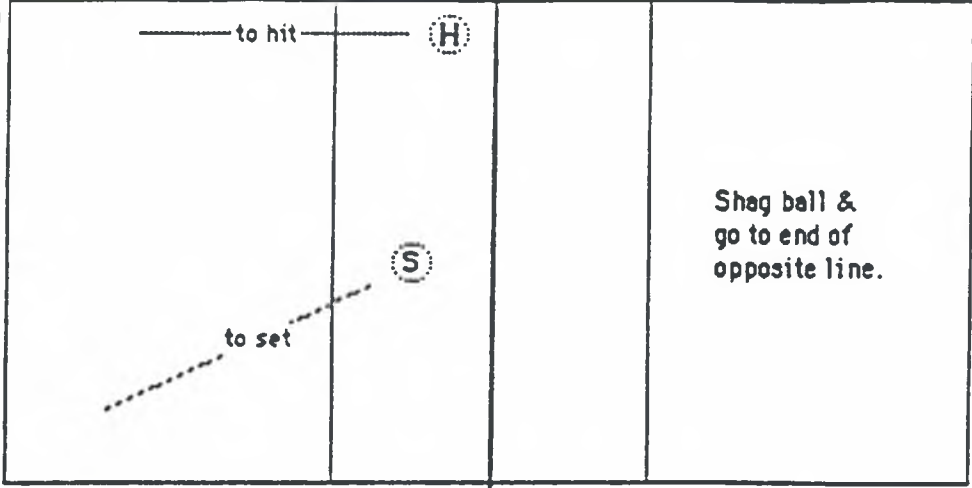

**Description** Lost Ball Drill Coach bounces ball into court - player runs to "find" it, passes to setter, and moves into position to become spiker. Emphasis on perfection of pass, set, hit. Run, stop, contact.

**Variations:**

- 1) turn players so their backs are to the court & yell go on the bounce.
- 2) lay both players in push-up position, then go on the bounce.

**Drill type**  
 Combination  
 Pass-Set-  
 Spike-Block

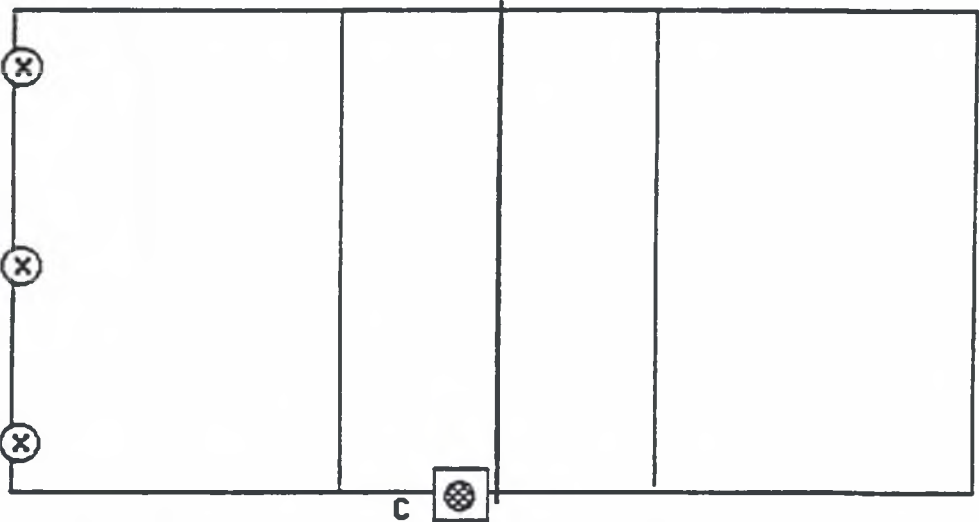

**Description** Three players lay down on stomachs with arms forward on the end line. Coach bounces ball high on court saying go. When hearing go, the players get up & play the ball with three hits. One shags ball & rest go to the end of the line. Very fast pace.

**Drill type**  
 Combination  
 Pass-Set-  
 Spike-Block

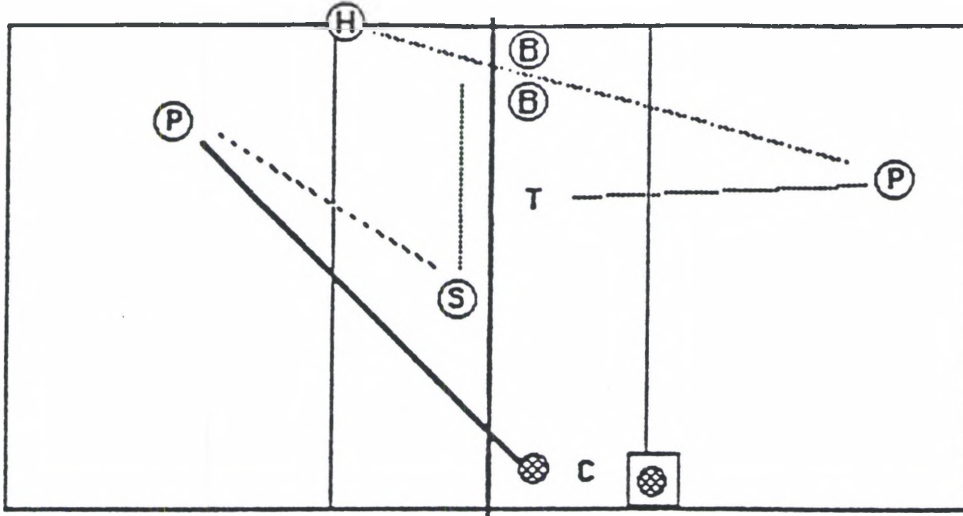

**Description** Coach tosses to passer who passes the ball to the setter. Setter sets to hitter & passer & setter cover. Middle & outside blockers move to set to block. Passer tries to read hit around block & pass to target.

**Drill type**  
**Combination:**  
 Pass-Set-  
 Spike-Block

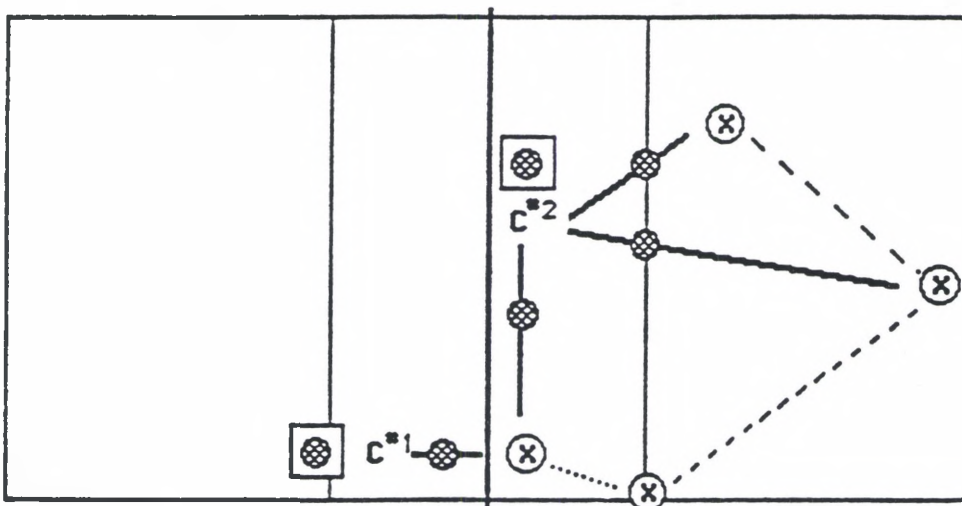

**Description** Coach #1 tosses three balls up for player to block in left front. Player backs up for approach and hits a ball tossed by coach #2 from left front. Once hit is converted, player back pedals to middle back. Player digs ball in middle back and coach #2 sets this ball for a back row attack.

**Drill type**  
**Combination:**  
 Pass-Set-  
 Spike-Block

## SECTION VII

### GAME PREPARATION AND RESPONSIBILITIES

There are numerous game preparations and responsibilities that a coach needs to take care of for each volleyball match. Most of these can be done by the assistant coach or the manager.

The first game preparation that has the highest priority is the net set-up. Some athletic directors leave the putting up and taking down of the game net to the custodians, while others put the responsibility into the varsity coach's hand. Either way, the net must be set-up properly at the height of seven feet, four and 1/8 inches. Bleachers should be pulled out, the score clock plugged in and the "National Anthem" ready to play. Obviously, the above duties are only for home matches. If the match is at another school, all the coach needs to do is get her team on the bus so it can depart on time.

The second game preparation is the scorebook. The scorebook needs to be filled out with the names of the players and their respective numbers. A team roster needs to be placed on the inside of the scorebook along with the line-up sheet filled out correctly for each game. The home team must also provide two line judges for both the junior varsity and the varsity matches. These people should be adults with volleyball knowledge, who could make unbiased calls on the direction of the ball while aiding the officials.

Another game preparation concerns the balls. Balls must be provided for the home and the away teams. Every ball should be marked with the school name to help keep track of them. A new ball that is not used for practice should be declared the game ball and be used only for games.

The medical kit is yet another game preparation which needs to be ready for each match. The medical kit should be on the team bench at all times and should have the following items in it: Band-Aids, safety pins, rubber gloves, athletic tape, safety pins, etc.



Each player can have their own water bottle, properly marked for usage during the match. The emergency medical forms can be kept in the medical kit for easy access in case of a player's injury. This form contains all the necessary information of the player's preference of doctor and hospital.

During the match, one of the responsibilities of the assistant coach or manager is to take accurate statistics. All statistic sheets should be run off before the season so they are ready for each game. They should be kept in a folder along with a box of pencils and a pencil sharpener. Also, a very helpful tool for game analysis, is the running score sheet. This sheet provides immediate feedback about the match by recording player performance.

Keeping track of player substitutions is yet another responsibility of the assistant coach. Players who start the game may only return to the game two additional times. They also may only return to the game in the same position that they left. However, a player who has not started the game may enter the game three times. Since a penalty can be assessed to the infracting team, keeping accurate track of substitutions is a very important job.

The last statistic which needs to be kept accurately relates to time-outs. There are two time-outs given to each team and an additional one is assessed if the game is tied at fourteen-fourteen. Accurate records must be taken during the game since a penalty can be imposed if the coach abuses this rule.

Finally, after the game, the last responsibility of the head coach is to announce the match results. The scores need to be released to the newspapers, radio and to the school for announcements in the morning. The phone numbers of the newspaper and radio station can be kept in the back of the scorebook for easy access.

All of these preparations and responsibilities need planning but can be efficiently executed if the coach is organized. The time spent in preparing these forms prior to the first match is definitely worth the time.

## SECTION VIII POST-SEASON

The volleyball season is not over for the coach after the last tournament game. The post-season includes additional coaching obligations to complete the season.

The first obligation of the coach during the post-season is to nominate players for individual awards. Nominating players for league and district recognition involves promoting their individual talents. At the league and district meetings, informational sheets including statistics and pictures should be made and distributed to each coach.

A second obligation is nominating players for state recognition. All state information needs to be sent to the poll voting coaches. This information needs to be prepared on a designated form and has a specific deadline to be met, in order for the player to be considered. This deadline is announced in the OHSVCA monthly newsletters.

The final obligation of the coach during the post season is the awards ceremony. This ceremony is an extremely important event for both the player and coach. A speech needs to be written relating to the highlights of the season, the team record, player information, etc. A nice idea to end the season with, is to distribute to every player a scrapbook. This can include a season summary, team rosters, scores and newspaper clippings. Team records and school records can also be included and updated.

The post-season provides the coach with a chance to recognize individual and team performances. It also allows the team to receive various memorabilia and helps to end the season in a positive manner.

## SECTION IX

### SUMMER PLANS

Summer is great time for players to work on their individual volleyball skills. A meeting with all perspective team members should be held before school is out for summer break. During this meeting, all of the following playing options should be explained and a calendar passed out to each player, indicating important dates and times of summer volleyball opportunities.

One opportunity for team members to participate in during the summer is to play second season volleyball. Second season volleyball league consists of area teams playing once a week during the month of June. A tournament is conducted at the end of the league with winning team advancing to the state second season tournament. Both varsity and junior varsity teams can participate.

Another option for summer participation is attending a volleyball camp. Camp information can be distributed and suggestions made to the specific camps which would be educational and worthwhile to attend.

Sand tournaments are also available in the area and provide additional opportunities for team to play the game on a different surface. These tournaments include doubles, quads, sixes, and co-educational playing opportunities.

Finally, players may decide to condition on their own. A summer work-out book can be passed out to each player which includes an individual work out plan. In this book are also drills and time sheets.

Every player has the chance to participate in any or all of the above mentioned summer volleyball opportunities. The coach needs to provide this information to her team so that each player can make the decision of how to improve her individual volleyball skills over the summer months.

## HANDBOOK BIBLIOGRAPHY

Gozansky, Sue, Championship Volleyball Techniques and Drills, Parker Publishing Co., New York, 1983.

Ohio High School Volleyball Coaches Association Drill Book, 1994

Scates, Allen, Winning Volleyball, Allyn and Bacon, Inc., Boston, Massachusetts, 1976.

True, Susan S., Volleyball Rules Book, National Federation of State High School Association, Kansas City, Missouri, 1994.

## CHAPTER V

### SUMMARY, CONCLUSIONS AND RECOMMENDATIONS

#### Summary

Since volleyball is one of the eleven high school sports that is available in the state of Ohio for girls to participate in, the writer was aware of the need of a handbook which would provide varsity coach's with current information. This information would include explaining current application of the rules, up-to-date techniques, new drills and multiple offenses and defenses.

The writer wanted to assist varsity volleyball coaches by providing guidelines and procedures relating to organizational duties such as compiling statistics, releasing match results to the media, and promoting individual and team performances. Thus, the writer's purpose was to write a coach's handbook which could be used by varsity volleyball coaches.

To find ideas for the handbook, the writer decided on a four step strategy.

This strategy included:

1. Review of textbook literature.
2. Review of personal library.
3. Review of handbooks.
4. Review of journal literature.

After completing her research for information, the writer was able to create a varsity volleyball coach's handbook. This handbook was designed to help the coach plan, organize and instruct a varsity volleyball team. The handbook was divided into nine sections consisting of the following areas:

- I. Coaching Philosophy
- II. Explanation of the Game
- III. Techniques
- IV. Pre-Season
- V. Season
- VI. Drills
- VII. Game Preparation and Responsibilities
- IX. Post Season
- X. Summer Plans

#### Conclusions

The writer hopes that the information presented in this handbook will be used by varsity volleyball coaches to help them run an efficient and effective program.

#### Recommendations

The writer reminds coaches that their own involvement is the key to the effectiveness of their volleyball program. The coach must conduct herself in a professional manner while performing the numerous duties needed to begin and maintain a competitive volleyball program. The writer recommends that the varsity coach use any of the ideas provided in the handbook and incorporate them into her own program.

## BIBLIOGRAPHY

- Asher, Kinda, "Happy 100th Volleyball", Volleyball USA, Vol. 22, Winter, 1995, pp.20-25.
- Chambers, S. (1991). "Factor Affecting Elementary School Students' Participation in Sports." The Elementary School Journal, 91, 413-419.
- Fuoss, D. and Troppmann, R. (1981). Effective Coaching: A Psychology Approach. New York: John Wiley and Sons.
- Jones, B., Wells, L. Peters. R. and Johnson, D., (1982). Guide to Effective Coaching. Boston, Massachusetts: Allyn and Bacon, Inc.
- Leith, L. (1990). Coaches Guide to Sport Administration. Champaign, Illinois: Leisure Press.
- Pointdexter, H. and Musher, C. (1973). Coaching Competitive Team Sports for Girls and Women. Philadelphia, Pennsylvania: W.B. Saunders.
- Sabock, R. (19679). The Coach. Philadelphia, Pennsylvania: W.B. Saunders Company.
- Vanderzwagg, H. (1988). Policy Development in Sport Management. Indianapolis, Indiana: Benchmark Press, Inc.
- Weiss, M. (1989). "Youth Sports: Is winning Everything?" Childhood Education, Summer, 195-196.