

## University of Dayton eCommons

---

Civil and Environmental Engineering and  
Engineering Mechanics Faculty Publications

Department of Civil and Environmental  
Engineering and Engineering Mechanics

---

6-2015

# Interface Friction Parameters for the Mathematical Modeling of Shell Structures with Infill

Alexander T. Bekker  
*Far Eastern Federal University*

Nikita Ya. Tsimbelman  
*Far Eastern Federal University*

Tatiana I. Chernova  
*University of Dayton*

Vadim D. Bruss  
*Far Eastern Federal University*

Ömer Bilgin  
*University of Dayton, [obilgin1@udayton.edu](mailto:obilgin1@udayton.edu)*

Follow this and additional works at: [http://ecommons.udayton.edu/cee\\_fac\\_pub](http://ecommons.udayton.edu/cee_fac_pub)

 Part of the [Geotechnical Engineering Commons](#), [Glaciology Commons](#), [Soil Science Commons](#), [Structural Engineering Commons](#), and the [Tectonics and Structure Commons](#)

---

### eCommons Citation

Bekker, Alexander T.; Tsimbelman, Nikita Ya.; Chernova, Tatiana I.; Bruss, Vadim D.; and Bilgin, Ömer, "Interface Friction Parameters for the Mathematical Modeling of Shell Structures with Infill" (2015). *Civil and Environmental Engineering and Engineering Mechanics Faculty Publications*. 62.

[http://ecommons.udayton.edu/cee\\_fac\\_pub/62](http://ecommons.udayton.edu/cee_fac_pub/62)

This Conference Paper is brought to you for free and open access by the Department of Civil and Environmental Engineering and Engineering Mechanics at eCommons. It has been accepted for inclusion in Civil and Environmental Engineering and Engineering Mechanics Faculty Publications by an authorized administrator of eCommons. For more information, please contact [frice1@udayton.edu](mailto:frice1@udayton.edu), [mschlangen1@udayton.edu](mailto:mschlangen1@udayton.edu).

## Interface Friction Parameters for the Mathematical Modeling of Shell Structures with Infill

Alexander T. Bekker; Nikita Ya. Tsimbelman; Tatiana I. Chernova, Vadim D. Bruss  
Far Eastern Federal University, School of Engineering  
Vladivostok, Russia

Ömer Bilgin  
University of Dayton, School of Engineering  
Dayton, Ohio, USA

### ABSTRACT

Thin metal or reinforced concrete shells with granular infill structures are considered in this article. These structures are massive and they are used as support for the construction of berthing quays, piers, artificial islands, shore protection, and other structures of coastal infrastructure. It is more convenient to use the thin shell structures during the development of the Arctic shelf, because it is possible to install them from the ice side. In addition, it is possible to enhance the technology and install thin shells with infill on deeper solid foundation layers. A mathematical model for the stresses on a compressible foundation soil in front of a thin cylindrical shell with infill due to the eccentric loading is developed. A modeling and experimental determination of the interface strength of the contact surface between the infill and the inner surface of the shell is proposed. The details of the construction stages and testing of the physical model used for the experiments are discussed. The effects of the interface friction on the shell behavior and on the foundation stresses in front of the wall are investigated. The influence of parameters affecting the interaction between the soil infill and the inner surface of the shell material is determined. It is based on a comparison of experimental results with calculations performed using the proposed mathematical model. The obtained parameters and proposed methods can be used in numerical simulations using the finite element method to analyze and design the thin shell structures with soil infill. The findings of the study and proposed methods can also be applied to the thin shell structures used in other facilities such as hydraulic, industrial, civil, and transportation.

**KEY WORDS:** Thin shell design; ground infill; mathematical model; computational model parameters; experimental studies; proof-of-concept.

### INTRODUCTION

Application of thin shells with infill improves the effectiveness of structures. Thin shells with soil infill are composite structures made for the most effective utilization of the desirable properties of their materials, i.e. steel or reinforced-concrete shells for the strength and granular infill for the massive weight. Modes of deformation of such structures depend significantly on the shape of the shell and size of the structures (Chernova et al., 2014). In this study, the thin steel cylindrical shells with large diameter (shell diameter,  $D$ , to height,  $H$ , ratio of  $D/H = 0.7$  to 1.0 and the wall thickness,  $t$ , to radius,  $R$ , ratio of

$t/R < 0.05$ , see Fig. 1) are considered.

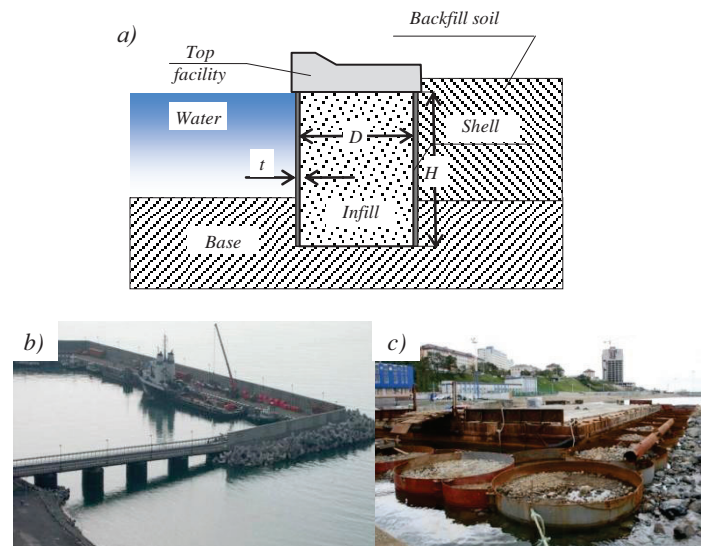

Fig. 1. Application of large diameter shells with infill: a) scheme of a vertical section of a shell (quay wall); b) a quay structure in the Port of Novorossiysk, Russia ( $D = 15.0$  m,  $H = 15.0$  m,  $t = 12$  mm)<sup>1</sup>; and c) berthing quay construction process in the Fedorov Bay, Vladivostok, Russia ( $D = 5.0$  m,  $H = 7.0$  m,  $t = 14$  mm)

In hydraulic engineering construction such facilities are applied as load-carrying structures in order to support jetties and bridge passages (they look like separate shells bridged by spans), and berthing facilities (one-row and multi-row close layout of shells with a common top slab). The schematic of a vertical section of a typical structure and pictures of some constructed facilities are shown in Fig. 1.

The greatest computational concern is accentuated on a case when the shell is affected by an eccentric loading causing increased pressures at the front end of the structure. There are number of loads in various combinations may act on these structures as listed in the following:

*Permanent loads:*

<sup>1</sup> Information was taken from the web site <http://www.morproekt.ru/>

- pressure of infill soil (in the simplified computational models the infill soil is modeled under an external load by Jansen's method);
- active soil pressure from a shore held by a shell;
- passive soil pressure in front of a shell (in case of pitching);
- loads from the fixed facilities above or behind the shell structures.

*Temporary long-term loads:*

- from transportation vehicles and loaders-unloaders located on the quay;
- from warehouse cargoes;
- from lateral earth pressures under temporary loads on the quay.

*Short-term loads:*

- from tension of mooring ropes when a moored vessel is affected by wind and flow;
- from weight of vessels on approaching a berthing facility;
- from leaning of the moored vessel affected by wind and flow on a berthing facility;
- from approaching wave crests and troughs;
- from ice;
- from wind;
- from transportation and installation of both individual elements and the whole unit as an assembly during the construction process.

In order to estimate the mode of deformation of a shell with an infill, the computational analysis requires the simulation of interaction conditions between the shell and soil infill. These conditions depend on the pressures on the inside face of the shell caused by the infill, the properties of the infill, and the surface conditions of the shell (surface roughness). The interior surface condition of the shell depends on the material used, manufacturing methods/conditions of the material, methods used for their joints, installation technology, and permanent and temporary bonds. Depending on manufacturing methods the shells may be welded of rolled sheets (Fig. 2 a, b), or installed as separate vertical segments connected by screw bolts (Fig. 2 c, d). Depending on the foundation soil conditions, such structures can either rest on specially prepared immovable beds or they are buried deeper into stronger foundation soil by vibropiling. The shells may be also formed by imbedding separate interconnected pile planks on tool joints (Fig. 2 e, f).

The effect of infill interface friction on the shell surface and the degree of shell surface roughness are considered in the computation model as properties of a conventional intermediate layer included between the shell and the infill. This layer (so-called "interface") allows consideration of changes of interior friction performances at the contact of the infill and the interior walls of the shell. The method of conventional layer construction in developing the computational model for a facility and the experimental method of its characterization is presented in this study.

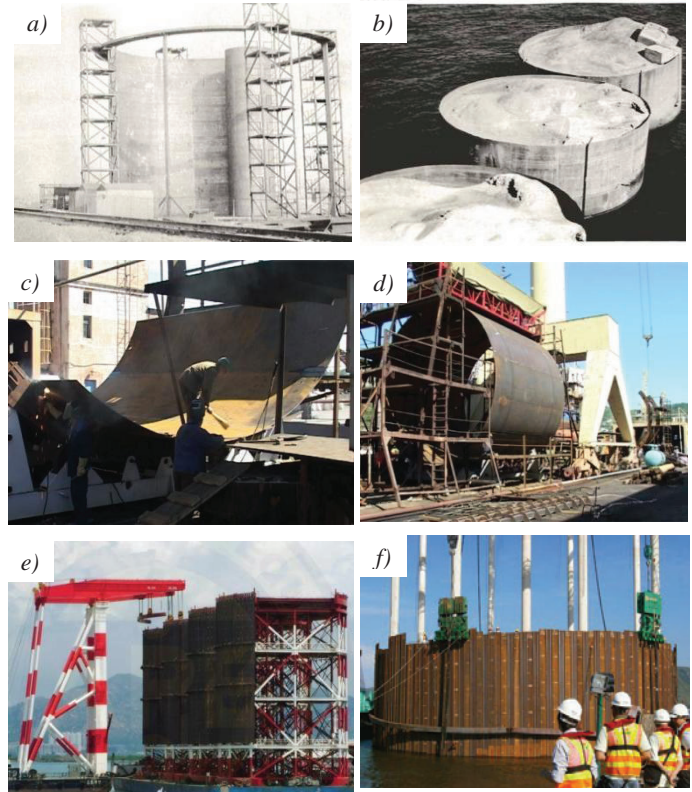

Fig. 2. Schemes of formation of cylindrical shells: a, b) jetty construction in the Port of Klaipeda, Lithuania with application of the shells made of rolled sheets ( $D = 15.0 \text{ m}, H = 12.0 \text{ m}, t = 10 \text{ mm}$ )<sup>2</sup>; c, d) large diameter thin shell assembled from separate vertical segments by welding for a berthing quay in Kozmino bay, Primorsky region, Russia; and e, f) constructions of cofferdams of the Hong Kong-Zhuhai-Macau Bridge project ( $D = 32.0 \text{ m}, H = 35.0 \text{ m}$ )<sup>3</sup>

## COMPUTATIONAL METHODS FOR SHELLS WITH INFILL

Various scientific studies on the development of theory and solution techniques for the static and dynamic loading conditions of separate units of the shell structures have been performed. Basic results in the field of mechanics of shells are described in the proceedings of outstanding researchers and engineers, such as V. Z. Vlasov, A. Lyav, S. P. Timoshenko, A. I. Lurye and many others, as summarized by Ivanov (1971). Many studies were also carried out to unite research on calculations of strength, sustainability, and dynamics of the thin-wall units interacting with the other objects (Ilgamov et al., 1977). Depending on the model used to describe the infill behavior, the studies in this field may be split in two groups.

The first group may include the studies where the infill is modeled by using the fundamental models such as the Winkler and Pasternak models (e.g., Ivanov, 1971; Ilgamov, 1977; Ariman, 1969; and Zerich, 1973). In this case, the design model is the simplest because the aspect ratios in such models are considered as stationary values and they do not depend on the geometric and physical performances of a structure. Outcomes obtained with these models may reflect sometimes the

<sup>2</sup> Information was taken from the web site <http://www.morproekt.ru/>

<sup>3</sup> Information was taken from the web site <http://www.iceusa.com/>

qualitative aspect of shell behavior. However, it is difficult to consider the quantitative aspect, because the proportionality factors remain unknown and the infill behavior remains undetermined.

The second group may include the studies where the infill is considered as a three-dimensional deformable body and it is modeled using the theory of elasticity or viscoelasticity. Thus it is possible to define three main directions: the first deals with the definition of the deformation mode of a structure (e.g., Eltyshev, 1981; Massalas, 1979), the second deals with the loss of stability under static loads (e.g., Gusev, 1974; Weingarten, 1962), and the third deals with a structure's behavior under dynamic loads (e.g., Ilgamov, 1977; Sann, 1966). Because of the assumptions made and the analysis approach used, these methods differ from each other. In most cases, they describe the structures in "classic" forms, such as a cylindrical shell with the infill. Basically, the solution of these tasks by the existing methods in a strict setting makes computing complicated and difficult to apply on current computers.

In design of shells with infill under complex loads founded on compressible soil layers, the traditional methods based on simplified equations of the space theory of elasticity are ineffective due to the complex nature of the structure and its interaction with the foundation soil. Currently the shell theory problems are solved widely by various numerical methods. Such methods improved significantly due to the major advances in current computing capabilities that makes it possible to solve the complex tasks of deformable rigid body mechanics relatively easily. The finite element method (FEM) is the most commonly utilized one among the numerical methods used for the shell analysis and design.

A numerical model of a cylindrical shell with infill was developed using the FEM to estimate the mode of deformation of the structure and it is presented in the following. The PLAXIS software was used for the numerical modeling (Brinkgreve, 2013).

### MODEL OF A SHELL WITH INFILL

The basic element of the presented structure is the soil serving as the infill for the shell. Soil also forms the base of the structure. The mathematical equations of the soil plasticity theory should represent some specificity of the mechanical behavior of soil materials. There are many soil mechanical behavior models available with various precision ratios. In this study, the infill is modeled as an elasto-plastic cylinder, and the foundation is considered as the elasto-plastic half space. The soil infill and the base are considered as plastically coercible elasto-plastic bodies. The Mohr-Coulomb model is selected as the constitutive model for the soil and it is explained in the following.

The Mohr-Coulomb model is considered as a first order approach in relation to the real soil behavior. The main parameters considered in this model are usually known to geotechnical engineers, and consequently it is popular. This model is a perfect plasticity model, where plasticity is characterized by non-reversible residual deformations in a material after removal of factors causing the deformations (Neto, 2008).

Unlike a standard type of elastic-perfect plastic model, the Mohr-Coulomb model has a multisurface outline of plasticity (Semenov, 2008). The Mohr-Coulomb condition of plasticity is a prolongation of the Coulomb's law of friction for a common state of stress. This condition may be completely determined by three functions of plasticity ( $f_1$ ,  $f_2$ , and  $f_3$ ) in their representation as functions of principal stresses  $\sigma_1$ ,  $\sigma_2$ , and  $\sigma_3$ ; and two soil properties (angle of internal friction,  $\phi$  and specific cohesion,  $c$ ) as:

$$\begin{aligned} f_1 &= \frac{1}{2}[\sigma_2 - \sigma_3] + \frac{1}{2}(\sigma_2 - \sigma_3)\sin\phi - c\cos\phi \leq 0 \\ f_2 &= \frac{1}{2}[\sigma_3 - \sigma_1] + \frac{1}{2}(\sigma_3 - \sigma_1)\sin\phi - c\cos\phi \leq 0 \\ f_3 &= \frac{1}{2}[\sigma_1 - \sigma_2] + \frac{1}{2}(\sigma_1 - \sigma_2)\sin\phi - c\cos\phi \leq 0 \end{aligned} \quad (1)$$

Plasticity functions shape a wrong hexagonal tripod signal in a room of principal stresses. Besides the functions  $f$ , the functions of plastic potential,  $g$ , are determined for the Mohr-Coulomb model as:

$$\begin{aligned} g_1 &= \frac{1}{2}[\sigma_2 - \sigma_3] + \frac{1}{2}(\sigma_2 - \sigma_3)\sin\psi \\ g_2 &= \frac{1}{2}[\sigma_3 - \sigma_1] + \frac{1}{2}(\sigma_3 - \sigma_1)\sin\psi \\ g_3 &= \frac{1}{2}[\sigma_1 - \sigma_2] + \frac{1}{2}(\sigma_1 - \sigma_2)\sin\psi \end{aligned} \quad (2)$$

These functions contain one more parameter of plasticity, a dilatancy angle,  $\psi$ , which characterizes the change of a material volume during shearing. This parameter is required for computed range-component increments of the positive plastic cubic strain and actually such case is more significant in denser soils.

A shell was modeled with PLAXIS 3D Foundation v2.2 software (Brinkgreve, 2013). This software includes a number of material models used in engineering practice, and the available database allows improvement of these models adapting them to operational conditions of a certain facility. Unlike other foundation software, PLAXIS uses the exact form of the complete Mohr-Coulomb model with abrupt jumping from one surface to another that makes it special among other models (Brinkgreve, 2013). The curvilinear surface of a shell is simulated by the PLAXIS standard tool kit, "circular tube" with subsequent automatic generation of the finite-element mesh using triangular elements. In the zones of special interests, such as supporting zones of a shell, it is desirable to assign additional clusters with the subsequent mesh refinement for more exact description of stresses and strains.

In order to better describe interaction conditions at contact of an infill with an interior wall of the shell, the intermediate (transfer) layer is entered into a computational model and the layer is simulated by a special element named "Interface" in the software. This layer makes it possible to simulate a process of change in soil strength properties (such as friction and cohesion, and other parameters depending on the selected mathematical model) on shell-soil contact. The general components of the finite element model used in the analysis and the interface layer are shown in Fig. 3.

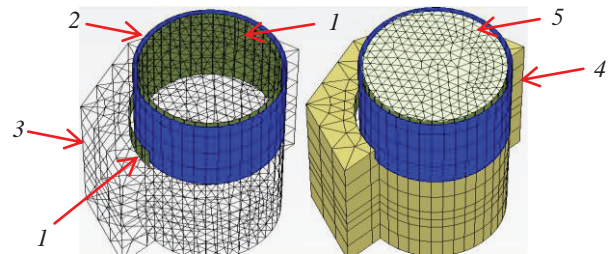

Fig. 3. Layout of conventional layers of the numerical model: 1-interface; 2-shell; 3 & 4-soil outside the shell; 5-infill soil

The transfer layer is responsible for changes in the physical and mechanical properties of soil during the course of structure lifetime

(like contact with another environment), it has a certain field of contact with a structure. Properties of the layer vary only within its thickness. This element possesses a number of strength and geometric performances which modification is followed due to soil hardening, soil creep, and slippage of a structure material, caused by the interaction area of the contacting materials.

Transfer layer material properties are linked to soil properties and introduced into the same data sets as the soil properties. The layers in the considered cluster and border get the same data set. In this study, the elastic-plastic model is used to describe behavior of interfaces to simulate the interaction between the soil and the structure. In order to make a boundary between the elastic behavior of the interface where small displacements may occur and its plastic behavior (slippage), the Coulomb criterion is applied.

In order for the transition layer to remain elastic, the shear stress  $\tau$  should be:

$$|\tau| < \sigma_n \tan \phi_i + c_i \quad (3)$$

where:

$$|\tau| = \sqrt{\tau_{s1}^2 + \tau_{s2}^2} \quad (4)$$

and  $\tau_{s1}$  and  $\tau_{s2}$  are the shear stresses in two (perpendicular) directions, and  $\sigma_n$  is the effective normal stress. In case of plastic behavior,  $\tau$  is:

$$|\tau| = \sigma_n \tan \phi_i + c_i \quad (5)$$

where  $\phi_i$  and  $c_i$  are an angle of internal friction and specific cohesion of the interface, respectively.

The interface properties are related to the properties of a soil layer. The layer-interface data set has the coefficient of strength reduction  $R_{inter}$  (Brinkgreve, 2013). Properties of the interfaces are determined on the basis of soil properties from the applicable data set and strength reduction coefficient by the following rules:

$$c_i = R_{inter} c_{soil} \quad (6)$$

$$\tan \phi_i = R_{inter} \tan \phi_{soil} \leq \tan \phi_{soil} \quad (7)$$

$$\psi_i = 0^\circ \text{ for } R_{inter} < 1 \quad (8)$$

Thus, if the soil model parameters are known, the transfer layer model is described by value of the strength reduction coefficient. For  $R_{inter} = 1$ , transition layer-interface properties including a dilatancy angle,  $\psi_i$  will be the same as the soil properties in the data set. In the actual soil-structures interaction, the interface has reduced strength, and it is more flexible than the soil layer, i.e.  $R_{inter} < 1$ . Due to insufficient reliable practical guides on assignment of this coefficient to the type of soil included in the structures considered, an attempt to define it with reference to the cylindrical shell structures filled with bulk solids is made in this study. Based on the results obtained from the experiments performed and the data from the design of these facilities, the range of approximate values of the strength reduction coefficient is proposed.

## EXAMPLE OF A DESIGN MODEL CONSTRUCTION

Construction of a small scale model of the shell with sandy infill is presented as an example. Dimensioning of the physical shell model and

soil characteristics including requirements of scaling theory is presented in the "Experiment" section. The numerical simulation of all experiment conditions is carried out to provide direct comparison of the results from the numerical simulation and the physical model experiment. Such comparison is necessary to verify the mathematical model and to define the transfer layer, and interface parameters on contact of the shell with soil infill. The soil properties used in the analysis for the Mohr-Coulomb model are shown in Table 1.

Table 1. Parameters of a soil model

Performance	Unit of measurement	Infill	Basis
Unit weight $\gamma$	[kN/m <sup>3</sup> ]	16	18
Modulus of elasticity $E_{ref}$	[kN/m <sup>2</sup> ]	16,000	23,000
Angle of internal friction $\phi$	[°]	26	32
Specific cohesion $c$	[kN/m <sup>2</sup> ]	2	2
Angle of dilatancy $\psi$	[°]	0	2
Poisson ratio $\nu$	[-]	0.3	0.3

In order to simulate the construction stages in PLAXIS software, the work planes of horizontal layers are previously assigned where construction material and the loads can be set/activated to model the sequence of construction stages. The working planes should be set at each level where a discontinuity of a geometrical model or the loading scheme occur. In this design case, division into some layers is provided for the foundation soil layer (in connection with non-uniformity of the soil throughout its depth) and for the shell.

In order to simulate a curvilinear surface of the shell structure, built-in *Pile - «Circular tube»* tool is used. The preparation of the finite element grid is divided into two stages: construction of a two-dimensional grid of elements and subsequent "extraction" of the scheme by connecting vertexes of two-dimensional triangular elements with the corresponding element points of the following working plane. The process is built on a resistant principle of triangulation which helps to find the optimum sizes of trigons and to plot an unstructured grid. In spite of the fact that unstructured grids do not form the regular patterns of elements, they yield the best numerical outcomes than the structured grids with a regular arrangement of elements (Brinkgreve, 2013).

Except grid construction, input information, such as boundary conditions and material data sets, is transformed from a geometrical model (points, lines, and clusters) to finite elements mesh data (elements and points). In the area near the base of the shell, the grid is extra optimized by local decomposition. In order to simulate a rigid cap of the shell by the same principles, a *Floor* tool is applied. The load applied to the cap of the structure is determined from the moment equilibrium conditions at the shell base. The moments are caused by the active soil pressure (held by a shell as a part of a quay structure) and by the equivalent point force applied to the cap. The external load is simulated by a *Pointloads* tool, and the force acts in a direction perpendicular to a prospective line formed by individual shells constructed next to each other.

The computational model generated (Fig. 4) consists of 15-node wedge-shaped elements with strength parameters describing soil condition; 8-node quadrangular plate elements describing a curvilinear surface of a shell; 16-node interface elements describing a curvilinear surface of interaction between a shell and soil; and 6-node triangular plate elements describing parameters of a rigid cap. The results obtained from the computational model considered in this section are

presented in the next section in comparison with the results obtained from the physical experimental model.

## EXPERIMENT

The selection of the required parameter values for the computational model are made based on the experiment carried out on a physical laboratory model of a shell with soil infill and analyzed by the authors. Thus a researched model and its operation conditions should simulate the real facilities and actual conditions in the field. The simulation conditions for the shell material and structure, as well as for the infill material, should provide the complete similarity of the stressed state of the model to the real case. In order to accomplish this task, the scaling theory and dimensional analysis methods (Kirpichev, 1953) are applied.

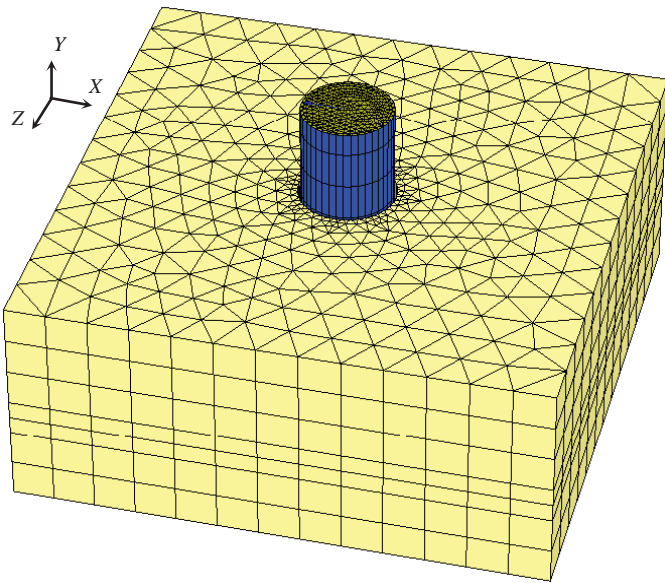

Fig. 4. A finite-element model of a shell with infill on compressible foundation soil

For the simulation, scale factors,  $\alpha$ , related to all values included into a set of equations for the real structure ( $X_n$ ) and in a set of equations for the model ( $X_m$ ) (Florin, 1961) are applied ( $X_m = \alpha \cdot X_n$ ). The factors used are:  $\alpha_\gamma$  is a scale for the volumetric forces/weight of a dead load;  $\alpha_\phi$  is a scale factor for the internal friction angle ( $\sin \phi_m = \alpha_\phi \cdot \sin \phi_n$ );  $\alpha_c$  is a scale for the cohesion. The applicable scale factors are also used for the dimensions, loads, and stresses:  $\alpha_l$  is scale for dimensions;  $\alpha_p$  is a scale factor for stresses.

The experimental setup was designed and built by the authors in order to study the behavior of shells with infill in laboratory conditions using physical models. Initially the parameters of the model were established taking into consideration the model rules with a scale of 1:20 (where the typical major shell with diameter  $D = 10$  m, height  $H = 14.5$  m, and wall thickness  $t = 0.014$  m served as a prototype). The shell model was implemented using plastic material with diameter of  $D = 50$  cm, height  $H = 72.5$  cm. The wall thickness,  $t = 0.5$  cm, was determined by considering rigidities of the real structure and the model, and including the scale factor. Dry sand was used as the infill material.

The detailed description of the laboratory setup, the basis for its sizes and material of the shell, simulation of the infill and loading conditions are given in the paper published by Bekker et al. (2014). This series of tests is carried out by using the basic parameters of the experimental

model. The scale factors  $\alpha$  for the experimental model are shown in Tab. 2.

Table 2. Scale factors used for small scale model

Material	$\alpha_l$	$\alpha_\gamma$	$\alpha_p$	$\alpha_\phi$
Shell	0.05	0.089	0.0045	-
Infill	0.05	1.6	0.08	1
Bedding	0.05	0.8	0.04	1

In this series of tests, strains and stresses of the shell model under eccentric loading are analyzed, taking into consideration that the shell is pinned in soil at the front end and it comes to a limit equilibrium condition for overturning during the course of testing. Comparison of the strains obtained from a physical model with displacements from the proposed mathematical model calculations will allow selection of an allowable range of values for the required parameter of the mathematical model, namely the coefficient of strength reduction  $R_{inter}$  on contact of the shell with infill.

The experimental setup was equipped by the loading gear, strain gauges, and tensiometers, in order to define stresses in the shell body. The loading gear setup allowed load to be applied horizontally to the shell cap. The schematic of the physical laboratory model setup along with the basic dimensions is shown in Fig. 5 and Fig. 6.

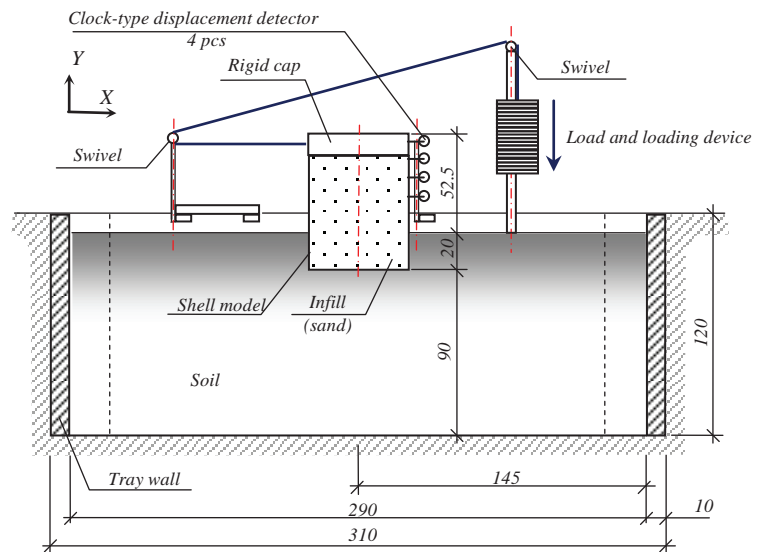

Fig. 5. Experimental setup and loading scheme of shell (dimensions are given in cm)

The shell cap was loaded gradually in stages until the complete overturning of the shell occurred. At every loading stage, the additional load was applied only after the strains from the previous stage of loading stabilized. The displacements measured at the top of the cap,  $\Delta$ , in the direction of the load applications (x-axis) as the load,  $P$ , applied are shown as Curve 1 in Fig. 7.

Additional series of calculations on the proposed mathematical model of facility was carried out. As the calculation is implemented for the conditions precisely corresponding to the conditions of the experiment (such as sizes, soil characteristics, and loading conditions as explained in the "Example of a Design Model Construction" section), it is possible to make a direct comparison of data obtained from calculation and the experiment. The series of calculations for various values of

strength reduction coefficient  $R_{inter}$  (from 0 to 1.0 with increments of 0.1) was carried out. The curves labeled as 2, 3, and 4 in Fig. 7 show the displacements computed for the coefficient  $R_{inter}$  equal to 0.2, 0.3, and 0.4, respectively. The figure shows only these curves of computed displacements, because the experimentally obtained displacements for all stages of loading are within the range of displacements computed with the coefficient  $R_{inter} = 0.3$  and  $R_{inter} = 0.4$ . Therefore the results show that the comprehensible range of values of the required parameter of the mathematical model (strength reduction coefficient,  $R_{inter}$ ) on contact of a shell with infill is between 0.3 and 0.4.



Fig. 6. The experimental model setup

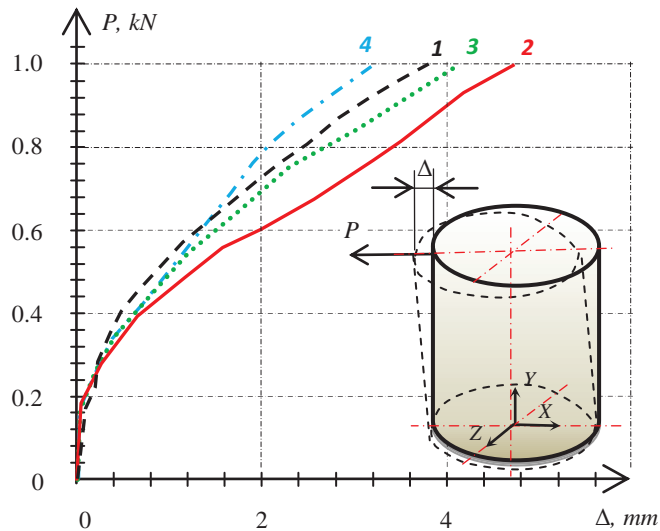

Fig. 7. Applied load versus the shell cap displacement

For determining the allowable value of the interface coefficient  $R_{inter}$  the design stresses originating in the shell body computed by the proposed model presented in sections “Model of a Shell with Infill” and “Example of a Design Model Construction” are compared with the pressure values obtained experimentally.

During experiments, IDTC-01 type strain-gauge manufactured by National Institute, teaching and research complex of Orel, Russia was used to determine the stresses in the shell body. The system converted signals of electrical resistance from strain-gauge transducers to digital

readout. The general layout of strain-gauge transducers on the shell body is shown on Fig. 8. Pre-stress calibration of the sensors pasted on the same material allows to judge by the indications of the registrar about the stresses originating in the thin shell body under loading. The stresses in the shell obtained from the computational model, with concentration on Point B which is located at the bottom of the front end of the shell, are shown in Fig. 9. The stresses in the shell obtained experimentally and their comparison with the design values are presented in Table 3.

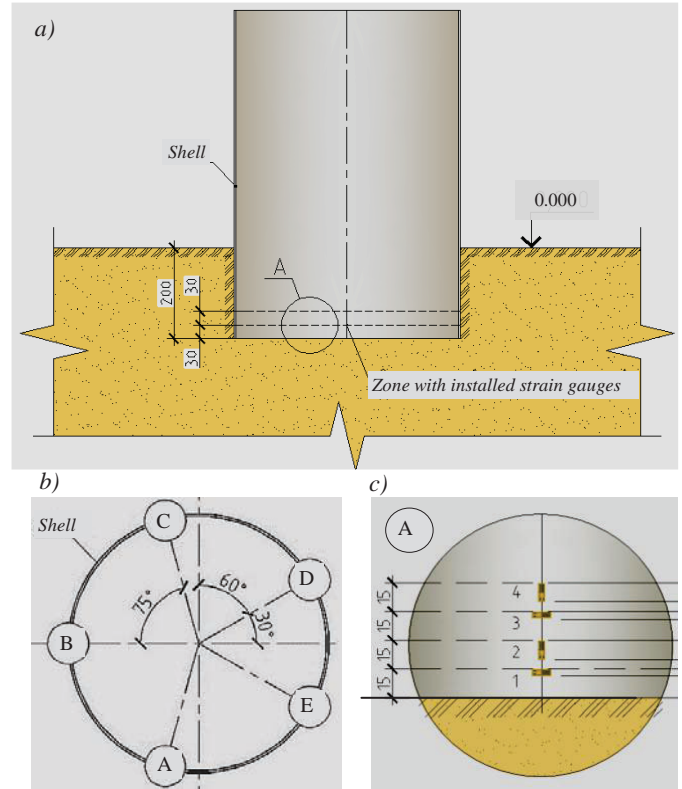

Fig. 8. The general layout of strain-gauge transducers on the shell: a) general view of the setup; b) the layout of gauge location points around the shell; c) typical sensor locations on profile view at any point (dimensions are given in mm)

Table 3. Comparison of the results obtained from experimental and computational models for Point B.

Force direction	Sensor Number	Stresses inside the shell ( $kN/m^2$ )		Difference (%)
		Experiment	PLAXIS	
Radial stress ( $\sigma_2$ )	1	-200.63	-181.75	9.4%
	3	-699.69	-665.34	4.9%
Longitudinal stress ( $\sigma_1$ )	2	-242.06	-252.99	4.3%
	4	-372.19	-389.51	4.4%

The results presented in Table 3 show that the shell stresses obtained from experiments and numerical modeling are within 5 % for radial stresses and 10 % for longitudinal stresses.

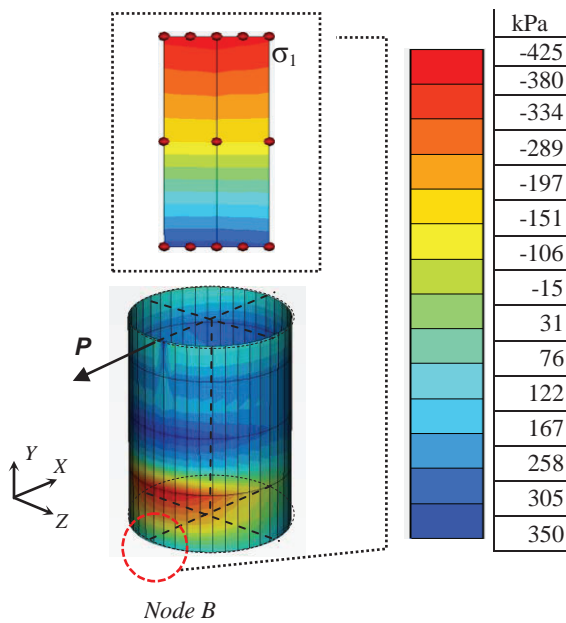

Fig. 9. Shell stresses (y-axis) obtained from numerical analysis with concentration at the front end of the shell base

## CONCLUSIONS

The finite-element modeling and analysis of an eccentrically loaded shell with infill structures using PLAXIS 3D Foundation software (Version 2.2) was presented in this study.

The relevant factor influencing the results from mathematical model entered into the software is the parameter of strength properties reduction  $R_{inter}$  within the so-called interface, i.e. the element through which the environments (for example, a shell and an infill) interact. Properties of the interface materials are connected with soil properties and possess the same data set. It is obvious that the interface in real soil-facility interaction has lower strength and it is more flexible than the applicable soil layer that means that the coefficient's value should be less than one. The interface parameters cannot be determined without physical experiment, and its properties will depend considerably on specificity of mutual functioning of elements in the considered facility.

In order to verify the offered model, the model tests of a thin-wall cylindrical shell with infill placed on a compressible foundation were performed. The measuring tools allowing determination of deformations and stresses in the shell body were utilized. The recommended range of the strength reduction coefficient values proposed to be applied in calculations of thin-wall steel cylindrical shells of large diameter with soil infill on compressible foundation soils is revealed in the study. The range of interface reduction coefficient values is 0.3 to 0.4.

Stress values obtained from calculations using the proposed model are compared with the experimental data. Radial stresses in the shell and compressive stresses along the shell originating in the contact zone of the thin shell and the base were evaluated in this study. This zone, the base in front of the shell, has a governing impact during the design of these structures with respect to the accepted performances of a material and parameters of a shell section as they define the local structural

stability. The offered model produces results agreeing reasonably with the experimental data (the stress values in the shell are within 10 %).

The design procedure of the considered facilities may further be advanced by studying the distribution of pressures between an infill and a shell over a facility base flange, as well as by considering the influence of non-uniform compressible deep soil layers on the stability of these structure.

## REFERENCES

- Ariman, T (1969). "Buckling of Thin Plates on an Elastic Foundation," *Bautechnik*, 46, N2, 59-63.
- Bekker, AT, Tsimbelman, NY, Potyanikhin, DA, Mamontov, AI, Bilgin, Ö, Chernova, TI (2014). "Mathematical Model of the Shell with the Infill for Retaining Structures". *The Proceedings of the Twenty-fourth International Ocean and Polar Engineering Conference (ISOPE -2014) Busan, Korea*.
- Brinkgreve, RBJ, Broere, W, Waterman, D (2008). "Plaxis 2D-version Finite Element Code for Soil and Rock Analyses," *User Manual, Rotterdam: Balkema* (Translated into Russian, 2009, SPb OOO "NIP-Informatika").
- Brinkgreve, RBJ (2013). "Tutorial Manual PLAXIS 3D Foundation," *Delft University of Technology & Plaxis bv. Netherland*
- Boldyrev, GG (2008). "Methods of Determination of Soil Mechanical Properties," Aspect Condition. Penza, *PGUAS*.
- Bugrov, AK (1974). "On Solution of the Mixed Task of Theory of Elasticity and a Theory of Soil Plasticity," *The Basis, the Foundations and Soil Mechanics*, N 6, 20-23.
- Chernova, T, Bilgin, Ö, Tsimbelman, N (2014). "Overview of Shells with Infill used in Geotechnical Engineering Applications," *The Proceedings of the ISSMGE Technical Committee 207 International Conference on Geotechnical Engineering, Russia, Saint Petersburg, 16-18 June*.
- Eltyshev, VA (1981). "The Mode of Deformation of the Shell Structures with the Infill," *Nauka*, 120
- Gusev, AM, Ivanov, VA (1974). "Stability of Plates on the Elastic Basis under Combined Loading," *Proc. of Seminar on a Shell Theory*. Kazan Physical and Technical Ins. of the USSR Academy of Sci, Kazan, Issue 5, 137-146.
- Ilgamov, MA, Ivanov, VA, Gulin, BV (1977). "Strength, Stability and Dynamics of Shells with Elastic Infill," *Nauka*, 332.
- Ivanov, VA (1971). "The Study Review on Stability of the Shells with the Infill," *Proc. of Seminar on a Shell Theory*. Kazan Physical and Technical Ins of the USSR Academy of Sci, Kazan, Issue 2, 5-25.
- Kenton, W, Braun, PE, Feifei, B, Guang, L (2009). "Local Ice Crushing Analyses of OPEN CELL SHEET PILE® Wall by 3DFoundation," *Plaxis bulletin Autumn*, N 26, 12-17.
- Kirpichev, MV (1953). "The Theory of Similarity". *M.: USSR, Academy of Sciences*.
- Lars, A, Lewis, E, Hans, PJ (2008). "Capacity Analysis of Suction Anchors in Clay by Plaxis 3D Foundation," *Plaxis bulletin*. N 24, October, 5-9.
- Massalas, C, Soldatos, K, Tzivanides, G (1979). "Vibration and Stability of a Thin Elastic Plate Resting and Non-Linear Elastic Foundation when the Deformation is Large," *J. Sound and Vibr.*, 67, N2, 284-288
- Neto, EA, Peric, D, and Owen, DR (2008) "Computational Methods for Plasticity", *John Wiley & Sons*.
- Sann, RI, Shaffer, BW (1966). "Free Transverse Elastic Vibrations of a Solid Cylinder Bonded to a Casing," *J. SIAM Appl. Math.*, Vol.14, N2
- Schanz, T, Vermeer, PA, Bonnier, PG (1999). "The Hardening Soil Model – Formulation and Verification," *Proc. Plaxis Symposium*



- "Beyond 2000 in Computational Geotechnics"*, Amsterdam, 55-58.  
Rotterdam: Balkema.
- Semenov, AS (2008). "Computational Approaches in the Theory of Plasticity", *SPbGPU publishing house*.
- Weingarten, VI (1962). "Stability under Torsion of Circular Cylindrical Shells with an Elastic Core," *ARS J.*, Vol. 32, 637-639
- Zaretsky, YK (1988). "Viscoplasticity of Soils and Computations of Structures," *Moscow Stroyizdat*.
- Zerych, S (1973). "Analysis of a Thin Circular Elastic Plate Resting on a Two-Parameter Winkler Type Foundation," *Bull. Acad. pol. Sci. Ser. Sci. techn.*, 21, N4, 247-253.