

1970

Radar Meteorology

Jerry Thomason
Ouachita Baptist University

Follow this and additional works at: https://scholarlycommons.obu.edu/honors_theses

 Part of the [Astrophysics and Astronomy Commons](#), and the [Earth Sciences Commons](#)

Recommended Citation

Thomason, Jerry, "Radar Meteorology" (1970). *Honors Theses*. 612.
https://scholarlycommons.obu.edu/honors_theses/612

This Thesis is brought to you for free and open access by the Carl Goodson Honors Program at Scholarly Commons @ Ouachita. It has been accepted for inclusion in Honors Theses by an authorized administrator of Scholarly Commons @ Ouachita. For more information, please contact mortensona@obu.edu.

H551.5
THO

RADAR METEOROLOGY

Project for;
HONORS SPECIAL STUDY

JERRY THOMASON

RADAR METEOROLOGY

I.	HISTORY OF DISCOVERY.....	1
II.	AFFECTS ON RADAR BY SOME SYSTEMS.....	1
	A. Moderate Rainstorms.....	2
	B. Thunderstorms.....	2
	C. Tornadoes.....	3
	D. Hurricanes.....	3
	E. Tropopause.....	3
	F. Sun.....	4
III.	REFRACTION, ATTENUATION, AND BACKSCATTERING OF ELECTROMAGNETIC WAVES IN THE TROPOSPHERE.....	4
	A. Refraction in the lower Troposphere.....	4
	B. Backscattering and Attenuation Gross Sections....	5
	1. Cause by Water Vapor.....	5
	2. Clear Air Backscattering.....	6
IV.	PULSE-RADAR SYSTEMS.....	7
	A. The Transmitter.....	8
	B. The Modulator.....	8
	C. The Duplexer.....	9
V.	ELECTROMAGNETIC PROPERTIES OF EQUIPMENT.....	11
	A. Cavity Oscillator.....	11
	B. Transmission Line.....	12
	C. Dipole.....	13
VI.	RADAR EQUATIONS.....	14

VII.	CHOICE OF WAVELENGTH.....	15
VIII.	RADAR SCREENS.....	16
	A. The PPI.....	16
	B. The RHI.....	17
IX.	DIAGRAM OF A UNIT.....	17

I. HISTORY OF DISCOVERY

Radar, an acronym for Radio Detection And Ranging, has been a great aide to the growth of the knowledge of science, especially for uses in weather research.

The discovery of the nature of radar is thought to have been made by Dr. A. H. Taylor and Leo C. Young of the Naval Research Laboratory when they found that radio waves would bounce back from steel. The military perfected radar for its benefits and gradually improved its technique of usage during the years of World War II. The British had its own version of radar and it is believed that its usage saved England during the aerial blitz by Germany during 1940 and 1941.

Weather was known to cause certain effects on the reception of radar since its initiation. Generally these effects were troublesome, but radar engineers soon developed techniques to pick up certain weather conditions such as thunderstorms and make flight plans for aircraft that would avoid the bad weather. Now the use of radar is very important because within just a few years, radar has been responsible for more advanced knowledge of the weather than any other instrument or device in the history of meteorology.¹

II. AFFECTS ON RADAR BY CERTAIN WEATHER PHENOMENON

Radars which use very short wavelengths are used

(2)

to detect effects produced by atmospheric conditions because of the reflective and refractive properties of the atmosphere at these wavelengths. Of all the factors of the atmosphere that affect the propagation of radar waves, precipitation has the greatest influence.

Moderate Rainstorms

These factors provide the radar observer much information that even a vast amount of ground observers could never obtain. The observer is provided constant information of precipitation intensity and area, thus they are able to predict flash floods very adequately and to predict future movements of storms.

Thunderstorms

The echo brightness on radar screens is proportional to the precipitation density. By proper adjustment of the equipment the observer can locate the sections of different intensities in a storm, and the stability of the storm. Turbulent weather has sharp defined edges, which light precipitations shows a fuzzy pattern. Even the exact height of clouds can be determined.

Probably the best aide for detecting and tracing severe storms such a tornadoes and hurricanes is the conventional weather radar unit.

Tornadoes

Studies of tornadoes have shown that cyclones usually form at the intersection of two lines making sharp changes in pressure in the atmosphere. They are likely to start in a region of active thunderstorms.² When a severe thunderstorm is being observed, the observer watches for the formation of a "six-like" loop that protrudes from a cell. This does not necessarily mean that a twister has developed but it is a good clue of the possibility of its formation. If a funnel is observed by visual means, then the hook image can be a predictor of the tornado's future path and thus allow proper safety precautions to be carried out.

Hurricanes

Vast information on the nature of hurricanes have been obtained by radar units. The radar pulses are deflected back from the rain carried by the storm. The huge storms form a very large "six" pattern on the screen with a clock-wise spiral. Often several small "six" shapes are observed indicating the presence of numerous tornadoes in conjunction with the hurricane.³ The eye's size and the height of the cloud deck can be determined by the scopes.

Tropopause

The tropopause has been detected by ultrasensitive,

(4)

narrow-beam, microwave and ultrahigh-frequency radars. Its reflectivity is consistent with theoretical data for such a medium. The layer is mechanically turbulent, and electromagnetic scatter techniques may be used to detect high-altitude clear-air turbulence.⁴

Sun

The Lincoln Laboratory of MIT now has a radar that probes the sun's corona, which is the breeding ground for radiation storms that affect weather on earth.⁵

The effect of radar on weather data can be summed up by: On the radar scope an observer can watch the birth, growth and dissipation of a storm, see snowflakes melt into rain-drops high in the air, follow a storm pattern as it moves across country and map air currents, all from his stationary shack.⁶

III. REFRACTION, ATTENUATION, AND BACKSCATTERING OF ELECTROMAGNETIC WAVES IN THE TROPOSPHERE

Refraction in the Lower Troposphere

Electromagnetic waves propagate through free space at a value called c , which is approximately 3×10^8 meters per second. When the vacuum is replaced by a material medium, this speed is reduced. In the atmosphere, pressure, temperature, and compositions affect the value of c . At radio wavelengths, water vapor strongly affects the speed of propagation and water vapor is the major contributor to atmospheric variations. The relationship of refractive modulus to pressure,

(5)

temperature, and water vapor pressure is given by the expression

$$N = \frac{77.6 P}{T} + \frac{373000 P_{vw}}{T^2}$$

where P_{vw} is the pressure of water vapor in millibars, P is pressure in millibars, and T is temperature in degrees Kelvin.⁷

Backscattering and Attenuation Cross Sections

Scattering and attenuation are complicated functions of particle size and dielectric properties. The square root of the dielectric constant, m , is

$$M = N - iK$$

where N is the phase refractive index and K the absorption index. It is convenient to use

$$K = \frac{M - 1}{M - 2}$$

in describing the dielectric properties of the troposphere. Then the wavelength is long in comparison with the size of the particles the backscatter and the absorption are relatively simple functions of K . The variation of the dielectric characteristics of water with temperature and wavelength is practically constant over a wide range in the centimeter range and is $|K|^2 = 0.93$. Similarly, $|K|^2 = 0.176$ for ice of normal density (0.917 grams/centimeter³).⁸

The echo power returned by a scattering particle

(6)

is proportional to its backscattering cross section, σ , which is the projected area which reflects isotropically the same amount of power towards the receiving aerial as the average power from the real objects being considered.⁹ The power removed by a particle is proportional to the total absorption cross section, σ_t . The cross section of spherical particles whose diameter is small relative to the wavelength is given by the Rayleigh scattering law,

$$\sigma = \frac{\pi^5}{\lambda^4} |K|^2 D^6$$

where λ is the wave-length, $|K|^2$ is the dielectric property, and D is the particle diameter. This accounts for the fact that a waterdrop reflects about five times more power than does an ice particle of the same size. Although the power backscattered by a single drop is small, the echo is caused by all the drops within a region. Since precipitation particles occur in number of about one thousand per cubic meter, a large number of particles cause backscatter simultaneously.

Radar backscattering from a clear air region is caused by irregular, small-scale fluctuations in the radio refractive index produced by turbulent mixing.⁹ The refractive index fluctuations are the result of variations in the physical properties of the air or

$$N = -1.27\Delta T + 0.27\Delta P + 4.5\Delta E.$$

In the convective process, a parcel of air with buoyancy due to a temperature or moisture excess passes through an ambient environment. The refractivity fluctuations are most pronounced at the outer edges of the parcel therefore energy will be scattered at these regions. The greatest scattering occurs at the top of the parcel. On the scope the cell appears as a disc and on the height scope it appears as an inverted bowl. Since moisture variations have the strongest affect on radio refractive index changes, Radar sees moist convection quite easily.

An ovserver must be able to tell if the echos are produced by turbulence in the air by convective cells or if they are caused by precipitation. Convective cells generally appear fuzzy and their echos will disappear if the power is increased.

IV. PULSE-RADAR SYSTEMS

A series of accurately timed and very short pulses of radio frequency must be obtained in a radar unit. The formation of such waves are formed in the transmitter. Its purpose is the formation of a high-power dc pulse, which is then applied to the output tube to produce a high-power carrier-frequency pulse. Since the duration of each pulse is very small compared to the time interval between two successive pulses, the

power in each one may be quite high without the average power becoming excessive.

The Transmitter

The transmitter consists of a self-oscillating power valve, usually a magnetron which is switched on and off to produce pulses by means of a modulator.

There are two types of modulators, one type in which the desired switching pulse is produced by very low power and subsequently amplified by a series of hard vacuum valves to the power level required by the output valve. In the other main type, the artificial line modulator, the required output pulse energy is stored on a system of condensers and inductances equivalent to a length of high voltage transmission line.

The Modulator

The modulator takes energy at a low power level from the primary electric supply and delivers very short pulses at a high power level to the transmitting output tube. The energy output of the modulator is less than the input, but the output of the modulator power exceeds the average input power. The basic principle of operation is to charge an energy-storage circuit slowly from the primary supply and then discharge it rapidly into the transmitter output tube. A switch is used which rapidly changes a circuit connection and brings this about.

In order to produce a dc pulse having the desired shape, a high voltage transmission line, or delay line, is used as the energy-storage circuit. The input end of the line is connected to a high voltage supply, but the output end is left unconnected during the charging time. A small current flows into the line, slowly charging it to the same voltage as the primary supply. When the transmission line voltage equals the supply voltage, no current flows. In order to deliver a high-power pulse a switch suddenly connects the charged line to the circuit containing the transmitter output tube. The impedance of this circuit matches the impedance of the transmission line. The charge moves delivers a pulse to the output tube.

The switch may be either a vacuum tube or a gas tube, usually a thyatron, a gas-filled valve of extremely high current capacity.

The Duplexer

In pulse radar systems the transmitter and receiver occupy the same antenna. It is necessary to disconnect the receiver during the transmitting pulse to protect the sensitive receiver, and in order not to lose any echo power, to prevent the transmitter from absorbing the signal that returns after the transmitted pulse. This is accomplished by the duplexer. It consists of two switches, usually gas-discharge tubes,

which open or close in the presence or absence of transmitter power. During the transmitter pulse the gas ionizes and the impedance across the tube is zero. In the absence of the transmitter pulse the gas is deionized, and the impedance is infinite. Use is made of the following impedance relations in transmitting lines and waveguides:

(1) $\frac{1}{4}$ wavelength away from a short circuit the input impedance is infinite, and $\frac{1}{4}$ wavelength away from a point of infinite impedance the input impedance is zero; and (2) wavelength away from a point of infinite impedance the input impedance is infinite.¹⁰

The transmitter lines or waveguides from the transmitter output stage and the receiver input stage are brought to a junction, and the common point is connected to the antenna. A gas tube, the transmit-receive (TR) tube, is located in parallel with the line connected to the receiver one-quarter wavelength from the junction, and another gas tube, the anti-transmitter-receive (ATR) tube, is placed in series with the line connected to the transmitter one-half wavelength from the junction.

When the transmitter pulse is on both gas tubes ionize. The one in series with the line from the transmitter forms part of the conductive path carrying the output to the antenna. But the gas tube across the line leading to the receiver produces a short circuit across the line and presents an infinite impedance in the direction of the receiver at the junction. Therefore

none of the transmitter power goes to the receiver.

In the absence of the transmitter pulse both tubes act as open circuits. The tube in series with the transmitter line causes the impedance looking toward the transmitter line from the junction to be infinite, so none of the echo power flows to the transmitter. The gas tube across the receiver line causes the impedance looking toward the receiver from the junction to be zero, so all the echo power from the antenna is channeled to the receiver.

V. ELECTROMAGNETIC PROPERTIES OF EQUIPMENT

The nature of electromagnetic waves in each part of the equipment can be described as a transverse wave, but each unit has its own characteristics.

Cavity Oscillator

The electromagnetic cavity oscillator is a closed cylinder whose radius is a and its length l , and its material is made of some good conductor. A system of oscillating electric and magnetic fields can be set up in such a cavity if the cavity contains no material medium. The cavity oscillations can be set up by connecting the cavity to a magnetron.

The E and B vectors change with time in the cavity. The cavity if assumed to be a parallel-plate capacitor will have for the energy stored, the values

(12)

$$U_E = \frac{1}{2} \epsilon_0 E^2 \quad \text{and} \quad U_B = \frac{1}{2} \frac{1}{\mu_0} B^2$$

where μ_0 and ϵ_0 are the permeability and permittivity constants, respectively, E is the Electric vector, B is the magnetic vector, and U is the energy produced.

The angular frequency of oscillation for the electromagnetic cavity is given by $\omega_1 = \frac{1.19}{a} c$.

c can be expressed as the inverse of the square root of the electromagnetic quantities. By applying Faraday's law

$$\oint E \cdot dl = - \frac{d\Phi_B}{DT}$$

to the line integral of the cavity,

$$\oint E \cdot dl = hE(r)$$

where $E(r)$ depends on Φ_B . Thus, the electric field will be a maximum when the magnetic field is zero.

Likewise by reducing Ampere's law

$$\oint B \cdot dl = \mu_0 \epsilon_0 \frac{d\Phi_E}{dt} + \mu_0 i$$

by similar approximation shows that

$$B(r) = \frac{\mu_0 \epsilon_0}{2\pi r} \frac{d\Phi_E}{dt}$$

Thus, the magnetic field depends on the electric flux E ; B has a maximum value when E is zero. This describes of E and B and their interdependence of each other on each other to carry out a sustained electromagnetic oscillation.

Transmission Lines

Transmission lines such as coaxial cables and

hollow waveguides are used to transfer electromagnetic waves.

Coaxial cables consist of an interior conductor such as a wire and surrounded by a non-conductor which is surrounded by another conductor. The two conductors can be connected by a switch. These are all arranged in such a manner that an electromagnetic oscillator will cause a sinusoidal wave by periodically throwing the switch. The traveling wave will have a wavelength given by $\lambda = \frac{c}{v}$. The coaxial cable is not a resonant device.¹¹

The Dipole

The dipole is attached at the radiation end of the transmission line. As the wave in the transmission line sinusoidally reaches the dipole it causes the effect of changing the dipole moment of the electric dipole with time, therefore the dipole moment oscillates as the charges in the transmission line oscillates. These oscillating currents generates varying B and E fields which move away from the dipole with speed c. The speed of the wave in free space is

$$c = v \lambda$$

which can be written as

$$c = \frac{\omega}{k}$$

(14)

where ω , the angular frequency, k , the wave number, are related to the frequency ν and the wavelength λ by

$$\omega = 2\pi\nu \quad \text{and} \quad k = \frac{2\pi}{\lambda}$$

VI. RADAR EQUATIONS

Suppose the transmitter radiates an average power of P watts at λ . If this power is radiated equally in all directions by the aerial then the power per unit area crossing a spherical surface of radius R centered on the aerial is

$$\frac{P}{4\pi R^2} \text{ watts.}$$

The aerial is used to concentrate the radiated power in a particular direction, and the increase in power flowing in this direction compared to a omni-directional aerial is called the aerial gain. If the gain of the transmitting aerial is G_T , then the power per unit area at range R_T is:

$$\frac{P G_T}{4\pi R_T^2} \text{ watts.}$$

The power reflected from the target is

$$\frac{P G_T \sigma}{4\pi R_T^4} \text{ WATTS/UNIT AREA.}^{12}$$

If the unit is a monostatic radar then the power density at the receiving aerial is

$$\frac{P G_T \sigma}{16\pi^2 R_T^4} \text{ WATTS.}$$

Just as the transmitting aerial concentrates the radiated power in a particular direction, so the receiving

(15)

aerial collects power more efficiently from a particular direction. If an aerial has a gain as a transmitting aerial of G_R , then it has an effective collecting area A , where

$$A = \frac{G_R \lambda^2}{4\pi} \text{ meters.}$$

Therefore the collected by the receiving aerial is

$$\frac{P G_T G_R \lambda^2 \sigma}{64\pi^3 R_T^4} \text{ watts.}$$

Whether or not this power can be detected as a signal depends on many factors such as noise, the amount of interference reaching the aerial, and the time available for the observation.

If the minimum power detected by a particular system is denoted by S_{\min} , the expression can be rearranged to give

$$R^4 = \frac{P G_T G_R \lambda^2 \sigma}{64\pi^3 S_{\min}}$$

where R is the maximum range of the radar.

VII. CHOICE OF WAVELENGTH

Radars can employ all wavelengths from a few meters to a fraction of a centimeter. The choice is affected by a large number of considerations. The size of the aerial for a given directivity is proportional to the wavelength and for a given aerial size the maximum range is inversely proportional to the square of the wavelength and for a given aerial size the maximum range is inversely

proportional to the square of the wavelength. Short wavelengths are greatly affected by atmospheric conditions, therefore radars that are used for weather study are around the three centimeter range and wavelengths are less than three centimeters signals can be received from cumulous clouds.

Weather radar units must meet the following specifications:

(a) wavelengths of one to 30cm; (b) pulse transmission with high peak power (several megawatts); (c) pulse repetition frequencies that are hertz of several hundred; and (d) automatic azimuth and/or elevation angle scanning.¹³

VIII. RADAR SCREENS

The Plan Position Indicator

There are several types of scopes that display echos. These scopes are all cathode ray oscilloscopes, but the Plan Position Indicator (PPI) and the Range Height Indicator (RHI) are the ones used for meteorological purposes.

In a PPI system the position of the trace on the scope corresponds to the direction of the beam from the antenna. A reflection then appears as a bright spot on the oscilloscope, the azimuth of the spot being the azimuth of the reflecting object and the distance of the spot from the center indicating the range of the object. The intensity of the spot is a measure of the reflecting efficiency of the target.

The Range Height Indicator

The RHI is designed for measuring altitudes. Echos are shown on a scope and are displayed in coordinates of slant range and elevation angle giving a cross-sectional vertical view along some azimuth.

IX. DIAGRAM OF A UNIT

The following is a block diagram of a conventional radar unit:

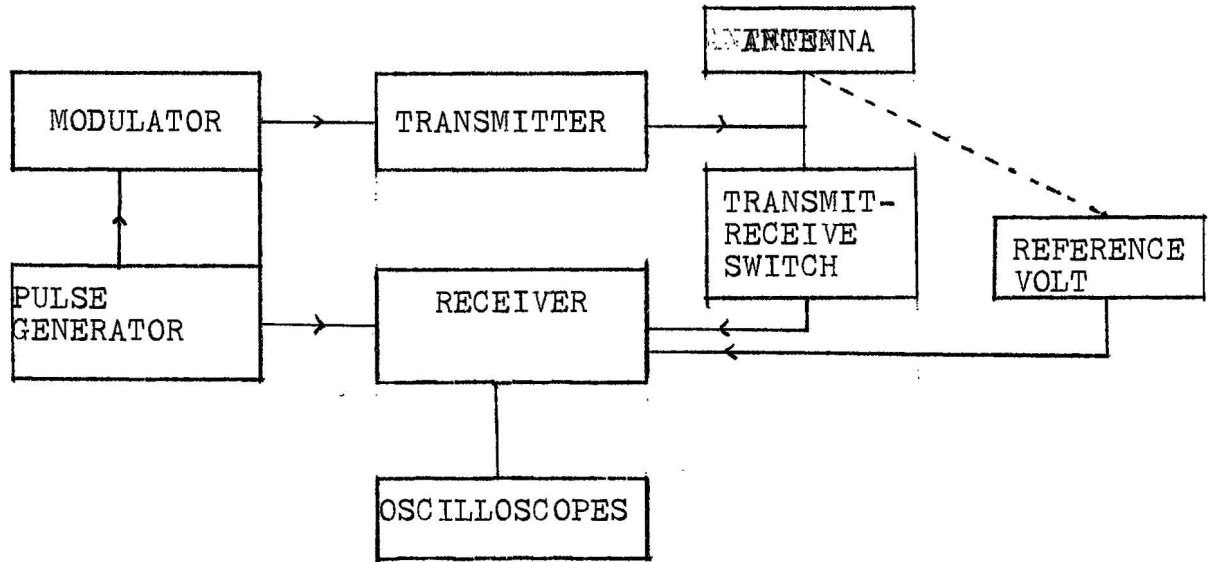

FOOTNOTES

1. Hal Foster, "Radar and the Weather", Scientific American, Vol. 189 (July, 1953), 34-38.
2. Ibid., 36.
3. "Radar may increase knowledge of meteorology", Science News Letter, Vol. 48 (October 27, 1945), 263.
4. G. X. Sand, "Back-Yard Radar Pinpoints Weather", Popular Mechanics, Vol. 112 (August, 1959), 133.
5. "Far-Out Forecasts", Newsweek, Vol. 59 (January 1, 1962), 30.
6. Op. Cit., 34.
7. V. J. Falcone, Jr., R. Dyer, "Refraction Attenuation, and Backscattering of Electromagnetic Waves in the Troposphere", Handbook of Geophysics and Space Environments, 1969, 3.
8. Ibid., 21.
9. "Radar Meteorology", Encyclopaedic Dictionary of Physics, The Macmillan Company, New York, 1962, 758.
10. "Pulse Radar Transmitter", McGraw-Hill Encyclopedia of Science and Technology, Vol. 11, 1960, 200.
11. David Halliday and Robert Resnick, Physics; Part II, John Wiley and Sons, Inc., New York, 1962, 975.
12. Op. Cit., 758
13. "Radar Meteorology", Van Nostrand's Scientific Encyclopedia, D. Van Nostrand Company, Inc., Princeton, New Jersey, 1968, 1457.

BIBLIOGRAPHY

1. Edward Adolphe, "Tornado Coming", Reader's Digest, Vol. 68 (May, 1956), 115-116.
2. Aeographer's Mate, Bureau of Naval Personal Training Course, NAVPERS 10362.
3. David Atlas, "Tropopause", Science, Vol. 153 (September 2, 1966), 110-112.
4. L. J. Battan, S. R. Browning, and B. M. Herman, "Attenuation of Microwaves by Wet Ice Spheres", Journal of Applied Meteorology, Vol. 9 (October, 1970).
5. B. R. Bean and E. J. Dutton, Radio Meteorology, National Bureau of Standards Monograph 92, U.S. Government Printing Office, Washington, D.C., 1966.
6. Ray C. Boston, "Radar Attenuation and Reflectivity due to Size-Distributed Hydrometeors", Journal of Applied Meteorology, Vol. 9 (February, 1970).
7. Roland J. Boucher, "CAT at a Subsidence-Inversion: A Case Study", Journal of Applied Meteorology, Vol. 9 (July, 1970).
8. James T. Bunting and John H. Conover, "On the Accuracy of a Precipitation Coverage Index Computed from Radar Reports", Journal of Applied Meteorology, Vol. 10 (April, 1971).
9. Wallace Clouth, "How the Weathermen can Listen in on Thunderstorms", Popular Science, Vol. 185 (October, 1964), 23.
10. Edwin F. Danielsen, Rainer Bleck, and Daniel A. Morris, "Hail Growth by Stochastic Collection in a Cumulus Model", Journal of Atmospheric Sciences, Vol. 29 (January, 1972).
11. V. J. Falcone, Jr. and R. Dyer, "Refraction, Attenuation, and Backscattering of Electromagnetic Waves in the Troposphere", Handbook of Geophysics and Space Environment, 1969, 3.
12. "Far-Out Forecasts", Newsweek, Vol. 59 (January 1, 1962), 30.

13. Hal Foster, "Radar and the Weather", Scientific American, Vol. 189 (July, 1953), 34-38.
14. Kendrick Frazier, "Into the Eye of a Storm", Science News, Vol. 97 (June 27, 1970), 621-622.
15. D. R. Hay, "The Birth of CAT and Microscale Turbulence", Journal of Atmospheric Sciences, Vol. 28 (July, 1971).
16. Thomas G. Konrad, "The Dynamics of the Convective Process in Clear Air as seen by Radar", Journal of Atmospheric Sciences, Vol. 27 (November, 1970).
17. John Lear, "How Stormy Weather is Born", Saturday Review, Vol. 42 (July 4, 1959), 31-36.
18. Allen Long, "Radar Spies on Tornadoes", Science News Letter, Vol. 65 (February 13, 1954), 106-107.
19. "New Thunderstorm Warning Service Utilizes Radar", Science News Letter, Vol. 55 (April 30, 1949), 281.
20. "Radar", Compton's Pictured Encyclopedia, F. E. Compton and Company, Chicago, 1961, Vol. 12.
21. "Radar", Encyclopedia Dictionary of Physics, Editor J. Thewilis, The Macmillan Company, New York, 1962.
22. "Radar", The Encyclopedia of Physics, Ed. Robert M. Besancon, Reinhold Publishing Corporation, New York, 1966.
23. "Radar", The Harper Encyclopedia of Science, Ed. John R. Newman, Harper and Row, New York and Evanston Sigma Inc. Washington, D.C., 1967.
24. "Radar Helps Weathermen", Science News Letter, Vol. 74 (November 29, 1958), 342.
25. "Radar", The International Dictionary of Physics and Electronics, D. Van Nostrand Company Inc., Princeton, New Jersey, 1961.
26. "Radar may increase knowledge of meteorology", Science News Letter, Vol. 48 (October 27, 1945), 263.
27. "Radar", McGraw-Hill Encyclopedia of Science and Technology, McGraw-Hill Book Company Inc., Vol. 11, 1960.
28. "Radar Pictures help predict flash floods", Science News Letter, Vol. 71 (June 22, 1957), 392.

29. "Radar's Future", Science News Letter, Vol. 47 (March 3, 1945), 131.
30. "Radar spots coming storm", Science News Letter, Vol. 56 (November 5, 1949), 293.
31. "Radar spots ice crystals in clouds", Science News Letter, Vol. 63 (January 3, 1953), 12.
32. "Radar, the Secret Word", Science News Letter, Vol. 43 (May 8, 1943), 300.
33. "Radar Tornado Warning", Science News Letter, Vol. 68 (July 9, 1955), 20.
34. "Radar", Van Nostrand's Scientific Encyclopedia, D. Van Nostrand Company Inc., Princeton, New Jersey, 1968.
35. G. X. Sand, "Back-Yard Radar Pinpoints Weather", Popular Mechanics, Vol. 112 (August, 1959), 133.
36. J. J. Stephens, Peter S. Ray, and R. J. Kurzeja, "Far Field Transcient Backscattering by Water Drops", Journal of Atmospheric Sciences, Vol. 28 (July, 1971).
37. R. A. R. Tricker, Introduction to Meteorological Optics, American Elsevier Company Inc., New York, 1970.
38. Philip D. Tompson and Robert O'Brien, Weather, Time Inc., New York, 1965.
39. "Weather Forecasters will use Radar Pictures", Science News Letter, Vol. 71 (May 11, 1957), 296.
40. "Weather Radar Net", Time, Vol. 68 (August 6, 1956), 43.
41. "What are the Facts about the Radar", Popular Science, Vol. 143 (August, 1943), 66-70.
42. Harvey E. White, Modern College Physics, D. Van Nostrand Company Inc., Princeton, New Jersey, 1966.