

1990

Training Student Organizers Curriculum (Revised Edition)

Michael Zamm

Robert Ortner

Beverly DeAngelis

Follow this and additional works at: <http://digitalcommons.unomaha.edu/slcecurriculum>

 Part of the [Curriculum and Instruction Commons](#), and the [Service Learning Commons](#)

Recommended Citation

Zamm, Michael; Ortner, Robert; and DeAngelis, Beverly, "Training Student Organizers Curriculum (Revised Edition)" (1990). *Curriculum*. Paper 31.

<http://digitalcommons.unomaha.edu/slcecurriculum/31>

This Report is brought to you for free and open access by the Service Learning and Community Engagement Examples at DigitalCommons@UNO. It has been accepted for inclusion in Curriculum by an authorized administrator of DigitalCommons@UNO. For more information, please contact unodigitalcommons@unomaha.edu.





COUNCIL ON THE ENVIRONMENT OF NEW YORK CITY

Marian S. Heiskell
Chairman

David Lenefsky
Vice Chairman

Richard Abrons
Secretary

Stella Stromboils
Treasurer

Lys Mc Laughlin
Executive Director

MEMBERS

Albert Appleton
NYC Dept. Of Environmental Protection

Joyce Phillips Austin

Martin S. Begun
NYU Medical Center

Dr. Arline Bronzalt
Lehman College, CUNY

Jeffrey Brooker
Webb & Brooker

William J. Dean
Attorney

Christopher Elliman
Elmrock Partners

Dr. Thomas H. Fay
Columbia-Presbyterian Medical Center

Dr. Edward F. Ferrand
The New York Lung Association

Aurora Gareiss
Udalls Cove Preservation Committee

Michael B. Gerrard
Berie, Kass & Case

Eric A. Goldstein
Natural Resources Defense Council

Elizabeth Gotbaum
NYC Dept. of Parks and Recreation

Dr. Irene Impellizzeri
NYC Board of Education

Ted H. Jacobsen
NYC Central Labor Council, AFL-CIO

Kenneth Knuckles
NYC Dept. of General Services

George Lamb
American Conservation Association

Bernard D. Lee
Pfizer, Inc.

Marjorie W. Longley
Gramercy International Inc.

Marcella Maxwell
Commission on the Status of Women

William Pierce
Chemical Bank

Steven Polan
NYC Dept. of Sanitation

Ellen O'Flaherty Pratt
Protectors of Pine Oak Woods

Lucius Riccio
NYC Dept. of Transportation

Ross Sandler

Frederick A.O. Schwarz Jr.
Cravath, Swaine & Moore

Roger L. Strong
Shearson Asset Management

Judith Walburg
United Negro College Fund

HONORARY MEMBER

John O. Riedl
Queensborough Community College

TRAINING STUDENT ORGANIZERS

CURRICULUM

Revised Edition

Prepared By

Michael Zamm

and

Robert Ortner
Beverly DeAngelis

NSLC
c/o ETR Associates
4 Carbonero Way
Scotts Valley, CA 95066

The production of this curriculum was made possible by
a grant from the Texaco Foundation

copyright 1990 by the Council on the Environment
of New York City

~~National Information Center
for Service Learning
1954 Buford Ave, Room R290
St. Paul, MN 55108-6197~~

51 CHAMBERS STREET, ROOM 228 • NEW YORK, NEW YORK 10007 (212) 788-7900

11/11/11
11/11/11
11/11/11

ACKNOWLEDGEMENTS

This curriculum manual could not have been completed without the skilled editorial and technical assistance of Louise O. Bryant, formerly of CENYC. We thank her.

Special technical assistance was provided by Dennis Bader of CENYC.

Assistance in the preparation of the curriculum was also given by:

Patricia Doyle, CENYC
Veronica Green, CENYC
Jacqueline Stewart, CENYC

We wish to honor the memory of Denise Hurtado, secondary author of the original Training Student Organizers Curriculum.

Cover design is by Anne Gaylor.

Word processing is by Andrea Ko Harmin.

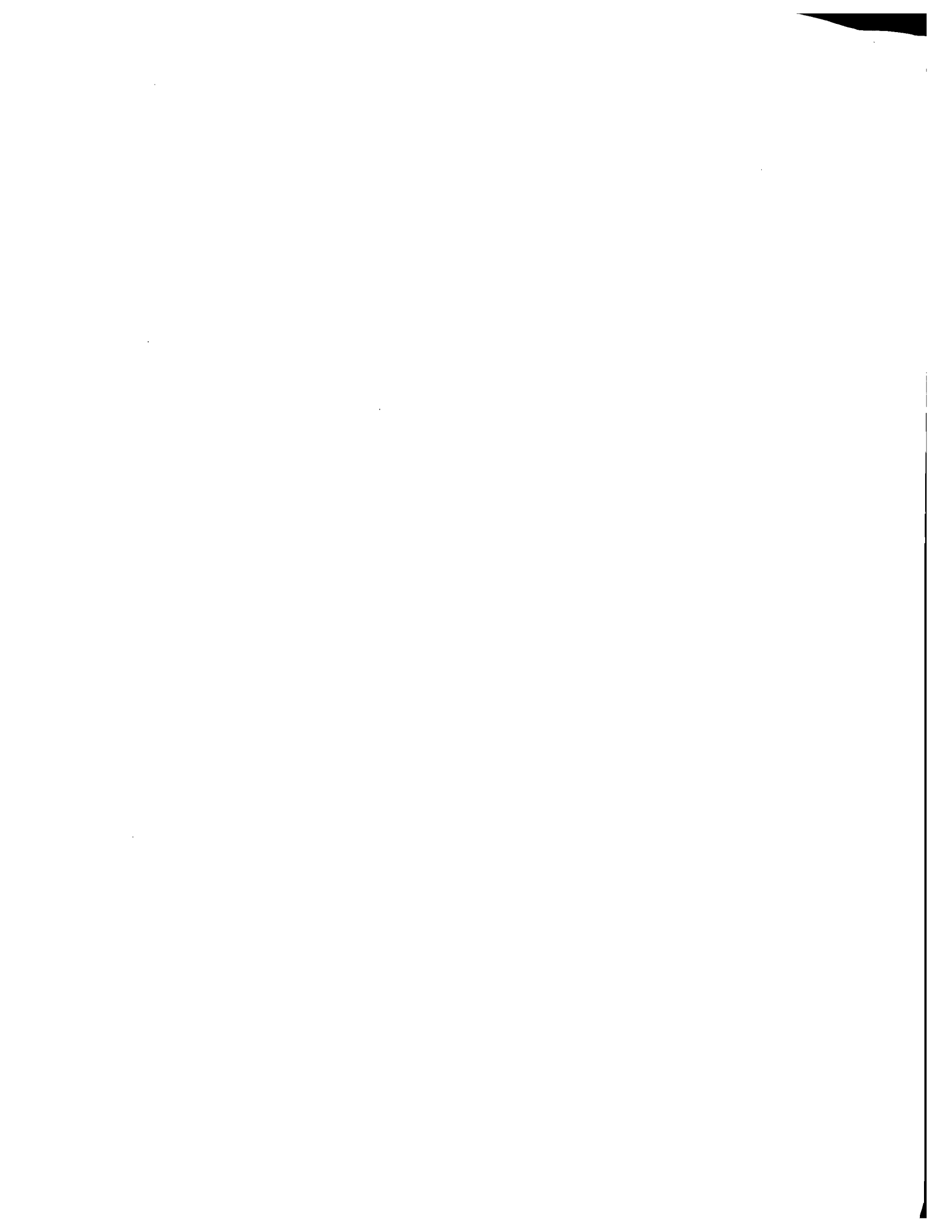

TABLE OF CONTENTS

General Introduction

PART I: ISSUES AND PROJECTS

Unit I: Energy Conservation

Introduction	1
The Issues:	
1. Energy Types and Sources	3
2. The Importance of Energy Conservation	4
3. Some Ways to Conserve Energy in the School, Home and Neighborhood	6
The Projects:	
A. Organizing a Classroom Electricity/ Lighting Conservation Project	9
B. Raising Funds For and Building a Demonstration Solar Collector	12
Auxilliary Materials	20
References	35

Unit II: Solid Waste

Introduction	36
The Issue:	
1. Solid Waste Problems and Solutions	37
2. Resource Recovery and How It Works	38
3. The Role of Recycling in Solid Waste Disposal	40
The Projects:	
A. Organizing a Neighborhood Cleanup/Sweep	42
B. Organizing an In-School Anti-Litter Campaign	45
C. Organizing a Survey/Report on Neighborhood Commercial Street Sanitation	47
D. Organizing a Small Recycling Project	50
Auxilliary Materials	55
References	65

TABLE OF CONTENTS....

Unit III: Water

Introduction	66
The Issue:	
1. Where Our Water Comes From and How It Is Used	68
2. How Sewage Treatment Plants Function	70
3. The Natural and Built Elements of the Environment Impacting on Drinking Water	71
4. The Importance of Wetlands in Protecting Open Waters and Drinking Water	72
5. The Impact of Acid Rain on Water Supplies	73
The Projects:	
A. Organizing a Letter-Writing Campaign to Protect a Drinking Water Supply	74
B. Organizing a Survey to Assess Conservation Efforts by Citizens	74
Auxilliary Materials	78
References	101

Unit IV: Air

Introduction	102
The Issue:	
1. The Sources and Types of Air Pollution	103
2. The Health Effects of Air Pollution	105
3. Air Pollution Controls and the Economy	107
Focus on Acid Rain:	
1. What Is Acid Rain?	108
2. Determining the Acidity of Precipitation	109
3. Where Does Acid Precipitation Fall?	110
4. The Effects of Acid Precipitation on Terrestrial and Aquatic Life Systems	110
The Projects:	
A. Organizing an Acid Rain Letter-Writing Campaign	111
B. Organizing a Letter-Writing and Public Awareness Campaign Concerning Chloro- fluorocarbons	112
References	116

TABLE OF CONTENTS....

Unit V: Open Space Beautification and Preservation

Introduction	117
The Issue:	
1. The Beautification and Preservation of Open Spaces	117
2. Street and Natural Area Beautification and Preservation	118
The Projects:	
A. Organizing a Park Cleanup and/or Gener- al Park Improvements	120
B. Organizing a Survey/Report on Park and/or Playground Conditions	121
C. Coordinating a Graffiti Removal Campaign	122
D. Organizing a Mural/Public Art Project	127
Auxilliary Materials	132
References	139

Unit VI: Noise Pollution

Introduction	140
The Issue:	
1. The Nature of Sound, Noise, and the Hearing Process	140
2. The Health Effects of Noise	141
3. What Is Being Done About Noise Pollution?	141
The Projects:	
A. Organizing a Letter-Writing and/or Petitioning Campaign to Lower Noise Levels of Public Transportation Vehicles	142
B. Organizing Educational Presentations on Noise Pollution to Elementary, Junior High, or High School Classes	144
C. Organizing Noise Awareness Days	145
Auxilliary Materials	148
References	158

Unit VII: Nuclear Energy

Introduction	159
The Issue:	
1. Nuclear Energy Types and Sources	160
2. The Advantages of Nuclear Energy	160
3. What Is Radioactivity?	160
4. The Workings of a Nuclear Power Plant	161
5. The Nuclear Fuel Cycle	163
The Projects:	
A. Organizing a Letter-Writing Campaign Con- cerning the Transportation of Radioactive Wastes	165
Auxilliary Materials	167
References	170

TABLE OF CONTENTS....

<u>Unit VIII: Transportation</u>	
Introduction	171
The Issue:	
1. The Various Modes of Transportation in a City or Town	171
2. The Role of Transportation in Our Lives	172
3. Future Modes of Transportation	173
4. Analyzing Needed Improvements in the Transportation System	174
The Projects:	
A. Organizing a Survey of Users' Attitudes Toward Their Transit System	174
B. Organizing a Survey on Citizen Attitudes Towards a Roadway Project	176
C. To Promote an Alternative Transportation System	178
Auxilliary Materials	180
References	184

PART II: PROCESS

Introduction

<u>Unit A: The Rationale for Citizen Participation</u>	
1. The Importance of Citizen Participation	181
2. An Analysis of Local Citizen Participation Trends	187
3. The Benefits of Citizen Participation on Environmental Improvement Projects	189
4. Organizing: An Effective Means of Motivating Participation	190
<u>Unit B: Needs Assessment and Project Selection</u>	
1. How to Assess the Needs and Problems of Our Community	190
2. Factors To Be Considered in Choosing a Project	191
3. Deciding on a Project	193
<u>Unit C: Project Planning and Initial Field Organizing</u>	
1. Resources Needed to Begin a Project	194
2. Initial Field Organizing	196
3. Preparation of a Press Release	197
4. Development of an Outreach Model for Motivating Participation in the Project's Initial Strategy	198

TABLE OF CONTENTS.....

5(a). Beginning Fundraising Techniques	200
5(b). Preparation of a Fundraising Letter	200
<u>Sample Materials</u>	
. Note on Press Releases	202
. Sample Releases	203
. Flyers with Notes on Posters, Leaflets, and Introduction Notices	205
. Sample Flyers	207
. Outreach Model	209
. Fundraising Letter	212
. Sample Fundraising Letters	213
. Field Interviews	216
. Sample Field Interview Sheet	217
<u>Unit D: Project Monitoring and Ongoing Participation Strategies</u>	
1. Methods to Involve Citizens on an Ongoing Basis	218
<u>Special Appendix</u>	
a. Note on Workshops and Group Presentations	220
b. Meetings	220
. Sample Agendas	222
c. Other Field Organizing Comments	224
<u>Unit E: Evaluation</u>	
1. Reactions and Development of the Student Organizers	225
2. Quantity and Quality of Participation	226
<u>Special Section on Letter-Writing and Petitioning</u>	
Introduction	230
1. Importance of Citizen Participation	231
2. Organizing a Letter-Writing Campaign in the School Community	232
3. Sample Letter #1	234
4. Sample Letter #2	236
5. Sample Petition	238
References	239

General Introduction

This second edition of the Training Student Organizers Curriculum has been written to reflect the project organizing experiences of students, teachers and staff participating in the Council on the Environment of New York City's Training Student Organizers Program (TSO) since the first edition of the curriculum was published in 1983. We have expanded the lessons/narratives in Part I to include more information on environmental issues and have also added lessons and/or narratives for specific environmental action projects. The "how to's" of project organizing are described, step by step, in specific improvement projects in Part I, and reviewed as a total process in Part II. While this has led to some repetition, teachers, youth leaders, and student organizers can turn to any specific project and read the lessons and/or statements in that section without having to read Part II unless clearly designated in the specific lessons. We have also added three issue units to Part I: Noise -- an addenda section in the original version; Transportation; and Nuclear Issues.

The issues and projects covered are mostly those we at CENYC regularly work on in TSO. These were chosen by program staff over time in consultation with students, school officials, government officials, and community residents with the environmental needs of New York City in mind. In developing each issue and project, however, we have tried to make them national and even global in application and the organizing steps outlined can be applied in one way or another to any environmental or social issue.

Not all lessons or suggestions are intended to fit into the usual 45 minute class period. Teachers, youth leaders, and experienced student organizers will have to apply the plans outlined or described here to whatever time frame they feel is realistic for their group within the structure of the institution in which they are working. It is also not necessary to follow each suggestion; the lessons and narratives are meant to be adapted to different situations.

A brief list of references is included at the end of each unit. These are either works that we have referred to in researching the curriculum or that are available to readers for additional information. These lists are by no means comprehensive. Specific information gleaned from a source is usually cited at the bottom of a page within a particular unit and lesson.

Please note that while this manual is intended for the teachers of high school and upper junior high school age youth, it can be applied to youth of all ages. Many college students have participated in TSO. Many of the projects are or can be streamlined for younger children or for "special" groups such as special education students. For example, a noise abatement letter-writing campaign can be done quickly and simply: one lesson to introduce the issue of noise; a field trip to measure noise levels of, for example, the local mass transit system; one or two lessons on writing letters to appropriate

public officials. Small scale aluminium can recycling projects, tree labeling, in-school improvements, acid rain letter writing, etc. can be organized quickly and effectively with students of all academic performance levels.

Note on Training Student Organizers Program (TSO)
History & Structure

Between March 1979 and June 1990, the Training Student Organizers Program has motivated nearly 7,400 students and their teachers to organize over 260 environmental improvement projects serving their schools, as well as over 60 neighborhoods in all five boroughs of New York City. The projects run the gamut of environmental services from clean-up campaigns, murals, and letter writing/petitioning efforts on environmental issues, to energy conservation projects, park improvement, recycling and tree labeling activities. Nearly 45,000 school children, youth and adults have participated in these projects.

While the program has traditionally been based primarily at 10 to 15 high schools and 1 to 3 colleges each year in regular social studies, science and art classes, in the past few years TSO staff have gone into elementary and junior high schools to train students to organize paper recycling projects. Beginning in the 1990/91 school year, the staff is planning to train 5th - 8th grade students of all academic performance levels to do multi-issue environmental organizing on a regular basis. Thus several primary schools in New York City hopefully will become long-term training sites.

In April 1990, TSO was presented with the National Environmental Achievement Award in Environmental Education by the National Environmental Awards Council's Searching For Success Project, organized by the Washington D.C. based environmental group Renew America. TSO also received a Friends of the United Nations Environmental Programme (FUNEP) "500" Achievement Award as part of the Searching For Success Project.

TRAINING STUDENT ORGANIZERS

CURRICULUM

PART I

Issues And Projects

UNIT I: ENERGY CONSERVATION

Introduction

Energy is defined as the ability to do work. The economy of the United States (and all other nations) is linked to the supply of energy. The dwindling supply of petroleum and natural gas threatens economic well-being and public health and necessitates development of renewable sources of energy to power our machines.

Fluctuating fuel prices, occasional shortages and blackouts, and a dependence on foreign sources of precious oil are problems that can be attributed in large measure to our nation's increasing appetite for, and decreasing domestic supply of available fuel.

The United States has only 5% of the world's population, yet we use 24% of the world's energy supplies. Nearly 50% of our national energy consumption is used for homes (20%) and transportation (28%) -- approximately one-half of transportation use is for motor vehicles.¹

The need for a comprehensive national energy conservation program is clear, as is the need for citizen and corporate involvement in such an effort. The controversy over the hazards associated with nuclear power production -- nuclear waste transport and disposal and nuclear plant accidents -- lends an urgency to our search for a sound approach to solving the energy problem, an approach which must involve both supply and conservation strategies.

The worsening of the "greenhouse effect" through the increasing amounts of carbon dioxide sent into the atmosphere by the burning of fossil fuels like coal and oil, and the deterioration of the ozone layer caused by the emission of chlorofluorocarbons from the production, misuse, and disposal of appliances such as refrigerators and air conditioners further accentuates the need for a national and global energy policy in which conservation plays an important role. The same is true for the acid rain problem, caused by sulfur dioxide and nitrogen oxide emissions from power plants and automobiles.

Alternative sources of energy, such as solar power, energy recovered from burning garbage, geothermal energy, etc., should continue to be developed and given priority in obtaining research funds. It is still unclear, however, exactly how much of our energy needs can be satisfied by solar, wind, geothermal,

¹ Facts from the U.S. Dept. of Energy, Energy Information Administration: State Energy Data Report -- Consumption Estimates, 1987 and Energy Facts, 1988.

expanded use of hydroelectric power, etc. Burning coal creates serious pollution hazards like acid rain. Pricing and tax policy mechanisms are effective but are not the only way to reduce energy use. Mass voluntary conservation can be effective and it is essential that we launch such an effort.

Leaving the lights, television, or radio on in an empty room, or leaving an air-conditioner on when no one is home wastes precious fuels. So do stop-and-go driving, running hot water excessively, or purchasing low efficiency appliances.

Home insulation (e.g., storm windows and doors, weather stripping and other materials that block cold and retain heat in the winter) conserve energy and lower fuel bills.

If every American made one change in behavior that led to a small reduction in daily energy use, we would probably reduce our energy needs considerably. The modest attempt to motivate Americans to conserve in the late 1970s led to a more than one-third decrease in reliance on imported oil.² That effort scratched the surface. More can be done.

² We now use about one-sixth less than we did in 1970. From U.S. Dept. of Energy, Annual Energy Review, 1988.

Energy Conservation: The Issue

Lesson #1

Aim: To learn about energy, its types and sources.

Motivation: Demonstrate the light and heat energy of the sun by holding a radiometer close to the window on a sunny day.

Discussion:

- a. What types of energy are causing the vanes of the radiometer to rotate?
- b. This light and heat energy comes from what source?
- c. Let's list the various types of energy and the natural and man-made sources.
- d. Make a chart like:

TYPES OF ENERGY	SOURCES OF ENERGY	
	<u>Natural</u>	<u>Man-Made</u>
Electrical	Lightning	Power plants (oil-fired, coal-fired, hydroelectric, nuclear, etc.)
Heat	Sun, human body, oil, coal, natural gas	Boiler....
Light	Sun	Power plants (oil-fired, etc.)
Mechanical	Wind, water, human body	Lever, pulley, pencil-sharpener....
Sound	Human voice	Saw, pencil-sharpener, musical instruments....
Atomic	Uranium	Nuclear power plant

e. What kinds of activities, machines, etc. do we need these different sources of energy for?

f. What is the one common factor or theme involved with these various types of energy and the things they are used for, i.e., how can we describe energy?

g. The students should come to understand that energy is the ability or capacity to work. Energy is the power by which anything moves itself or something else, or acts upon other things.

(Adapted from Energy Conservation Education: An Action Approach, Council on the Environment of New York City and New York State Energy Office, revised edition, April 1983.)

Lesson #2

Aim: To learn why energy conservation is important.

Motivation: Why is energy conservation important? What are the basic problems of energy in the U.S.?

Discussion:

a. Place the following chart on the chalkboard and/or photocopy it for the students:

PROS AND CONS OF PRIMARY SOURCES OF ENERGY Commercial/Residential Use, U.S.A.			
Source	%	Pros	Cons
Oil	40.3	Less air pollution than coal burning plants, relatively safe plant operation	Dwindling supply, dependence on imports, spills during transport, pollution from plants, cars, etc., price instability
Coal	24	Abundant supply, relatively lower prices and safe plant operation and transport	Land and air pollution, e.g., strip mining, acid rain, and mining safety hazards

<u>Source</u>	<u>%</u>	<u>Pros</u>	<u>Cons</u>
Natural gas	23.2	Clean provider of energy, generally cheaper than oil, relatively safe transport	Decreasing supply, some transport accidents
Hydro	6.0	Abundant supply	Ecosystem disruption, only functional in certain locations
Nuclear	6.0	Adequate supply of uranium	Nuclear plant accidents, nuclear waste disposal, increasing costs

Figures taken from several sources. The statistics represent a synthesis of information received from a number of public and private organizations.

b. Discuss the various positives and negatives associated with each source of energy listed above.

c. Can we afford to depend too much on any one source?

d. What are two of the relatively new pollution problems caused by energy production which have become major environmental problems? (Acid rain and nuclear waste; plan discussions on these. See "Air Pollution" and "Nuclear" sections of this curriculum.)

e. What is one key environmentally benign way we could reduce our dependence on these energy sources and give our nation more time to effectively cope with the problems associated with each energy source? (Conservation)

Followup:

*Ask the students to devise a national energy strategy for the next twenty years. Should we depend on one or two sources or develop a multi-source strategy? Should the nation develop a comprehensive national energy conservation plan taking into account both regional and national needs and factors? What problems do we need more time to solve?

*Ask the students to research the primary users of energy in the U.S., e.g., what percentage of U.S. energy goes toward industry, transportation (public transportation and automobiles), home use, energy loss through electricity generation, etc.

See Project B., Lesson 1 in PROJECTS section of this unit for a discussion of renewable energy.

Lesson #3

Aim: To learn ways of conserving energy in school, home, and neighborhood.

Motivation: Organize a walking tour of the school to analyze energy uses and possibilities for conservation in the building. For each energy user/provider, have students write down the fuel used, the total hours used, the unit costs, and possible methods of conservation. This will take one school period.

Discussion:

a. Where in the school and in and outside your home could you conserve oil, coal or gas?

b. What's the most obvious area for conservation in school?

c. Lighting represents a significant portion of school electrical use and of all electric power usage in America.

d. Outline some other possibilities for conservation in the school, e.g.,

- more efficient use of office equipment
- reduced lighting in hallways and areas like the gym or assembly
- careful use of oven, hot water, etc. in school kitchen
- better boiler maintenance, purchase of more efficient boiler when it is replaced
- more efficient use of air conditioning systems if applicable
- better insulation of windows and doors

e. What are some possible strategies for home conservation?

- reduced lighting
- more efficient appliances
- more efficient use of household heating and hot water systems, and construction of windows, roofs, overhangs
- more efficient use of household cooling system
- design of the house, whether private home or apartment building, e.g., to allow in more sun during the winter months and to keep it out during the summer. See Project B., Lesson 1 in PROJECTS section.

f. List some of the specific conservation possibilities in each aspect of home conservation, e.g., appliances: turn off the television when nobody is watching, etc.

g. What about conservation other than in the home or school?

- reduced use of automobile
- more public transit
- bikeways

Followup:

*Ask the students to devise a strategy for conservation (including implementation) for both the school and their homes. (See Projects section to develop this idea further.)

Lesson #4

Aim: To learn how energy affects housing.³

Discussion (use as Motivation):

a. What are the key functions that consume energy in an apartment building or private house?

- heat and hot water
- light
- electrical appliances for many purposes: elevator, sprinklers, refrigerators, etc.

b. Can a building function for an extended period of time without energy?

c. What do you think happens to a building when the energy systems start to decline?

d. Which of the energy systems is usually most essential to building upkeep and occupant health? (Heat and hot water--the boiler)

e. What happens when the landlord is no longer able to provide heat and hot water?

- Tenants suffer
- Tenants who can, leave and/or organize a rent strike
- Landlords let all services decline

³ We are talking about apartment buildings and other kinds of collective living conditions, where the functioning of the energy systems has not only physical and economic, but also immediate political and social implications.

f. Are there any possible solutions to these problems?

Consult with local government or non-profit housing agencies, community and tenant activists, etc. if there is student interest in this. The co-op and condominium conversions sweeping many of the cities in the U.S. make for an interesting discussion. How does the decline in a building's energy systems affect an owner's decision to convert to a cooperative or condominium?

Energy Conservation: The Projects

A. Organizing a Classroom
Electricity/Lighting Conservation Project

Lesson #1

Aim: To begin organizing a classroom electricity/lighting conservation project.

Motivation: Why is energy conservation important? What is the most practical way to conserve energy in the schools? (Elicit lighting conservation in the classroom -- it is the most under student/teacher control, and in most schools custodians already conserve heating adequately.)

Discussion:

a. Use the following outline in developing a classroom lighting conservation project:

Issue: Energy/Energy Conservation

Project

Strategy

Method

Service/Direct Action

Lighting conservation in classrooms using charts and worksheets; target group-- other science, social studies, etc. classes in school

b. Point out how conservation could be accomplished in the classroom by turning off the row of lights closest to the windows (if rows of lights are parallel to windows). If they are perpendicular, then choose row(s) that allow sunlight to cover biggest possible area.

c. Discuss how lighting conservation could conserve energy: supplies of coal, oil, etc.

d. Show (and photocopy -- see Auxiliary Materials after project B on p. 21-22) the Conservation Log and Kilowatt Hour Saving Graph. Discuss as specifically as possible terms such as

watt, kilowatt, kilowatt hour, ampere, volt, ohm. For definitions, see "Energy Conservation Education: An Action Approach" prepared by Council on the Environment of New York City and New York State office, available from New York State Energy Office, Office of Communications, Two Rockefeller Plaza, Albany, NY 12223.

e. Using Energy Conservation Charts and Sheets in the Auxiliary Materials section, have students figure out how much electricity, oil or coal, and money can be saved by shutting one row of lights in one classroom for each school day for an entire school year.

f. Start conserving in your room.

Follow-up

*Ask students to compute energy and money savings if each classroom in your school conserved one row of lights for each school day during an entire school year. What about all the schools in your city? See sheets in Auxiliary Materials section.

Lesson #2

Aim: To implement the project strategy and method.

Motivation: What is the best way to motivate students and teachers in the school to conserve lighting in the classroom?

Discussion:

a. Suggest to the students that one way to begin the motivational process is to stimulate the teachers, especially science and social studies teachers whose subject areas relate directly to energy conservation to enthusiastically introduce the project to their students.

b. Explain to the students that a presentation directly to all the targeted teachers would be a key step.

c. Work out the presentation format and content with the class. See the section on giving presentations, p. 220.

d. Presentation may include: Identification -- name and class of speaker--why it is important to conserve energy, why lighting conservation is realistic in the school, the use of energy conservation charts and worksheets.

e. Ask for students who might want to give such a presentation.

f. Start to role-play if time is available.

Followup:

*Select a group of students to contact (with class teacher if necessary) science or social studies chairpersons to set date and time for a presentation, approximately two weeks in advance.

*If it is more realistic, individual teachers can be contacted by small groups of students and motivated to do the project in informal conversations rather than by a formal presentation.

Lesson #3

Aim: To practice presentations, assign speakers, and finalize details for energy conservation talk.

Motivation: Spend at least twenty minutes in a role-play session in which some students give a presentation to their fellow students who play the role of the teachers to be motivated. Students will need to practice sharing a presentation to a group of teachers. This may take the whole session, or more if necessary.

Discussion:

a. Critique role-play.

b. Make sure all students know how to explain the charts and sheets. Make sure the students understand that projects can be done without using the worksheets extensively. Each participating class can simply conserve, calculate the watt hour and kilowatt hour savings and record them on the charts. Counting the fixture ballast most 4 foot bulbs are 50 watts and 8 foot bulbs are 100 watts. Simple bulb and fixture counts and multiplication and division will bring the kilowatt savings totals.

c. If there is time, make final assignments with regard to which students will make the presentations to a meeting of science and/or social studies teachers, or make informal contacts with individual teachers if that approach is to be used.

Lesson #4

Aim: To review outreach and monitor project.

a. If presentations have been given or contacts made, ask the students to report results; review how many teachers were or will be involved; and how many classes each participating teacher will include in the conservation activities.

b. Lay out a plan for monitoring the project. Assign students to visit teachers in their classrooms. (Most high

school and junior high school teachers teach their various classes in one basic room but some may work in two or three classrooms.)

c. Are the teachers and students shutting off the row (or rows) of lights nearest the windows when possible? When did/will they start? Are the charts being used? Are the sheets being used?

d. Figure out when the class should collect the charts and tabulate the numbers. Should results be publicized in the school?

Followup:

*Review monitoring plan each week. Collect charts or whatever records the teachers in each room compiled near the end of the term. Compile conservation results in the school and publicize to school authorities to show potential energy and money savings. Should the project involve other schools?

*Expand the energy conservation program in the building to include lighting conservation in public areas like the gym, assembly, hallways. Students could survey the school and prepare reports to the custodial staff and school administration recommending changes in lighting patterns, bulb wattages, etc., and a plan to educate the school (teachers, administrative and custodial staff) about how to conserve lighting in these areas. Similar auditing and report activities could deal with heat loss in the school, use of appliances in the kitchen, air conditioners, etc. Seek support from the local utility company and school custodial staff in developing such activities.

*Develop a similar conservation program for the students' homes. More advanced student organizers can organize meetings in their home buildings to start a home lighting, appliance, and heating conservation program.

B. Raising Funds for and Building a Demonstration Solar Collector

Lesson #1

Aim: To introduce the class to the concept of renewable solar energy.

Motivation: Summarize and discuss the basic points of Lesson #2 in the Issue section of this unit. (See pp. 4-5.)

Discussion:

a. Remember the various supply, pollution, exploration, cost and transport problems associated with current primary sources of energy?

b. Energy conservation is one approach to take.

c. What are renewable energy sources? (Explain or elicit definition of renewable energy sources as sources whose use does not deplete or use up their supply. The sun is continuously providing a supply of solar energy, for example.)

d. What are the various types of renewable energy? Use the following chart and discuss.

e. Consider all the factors involved in energy use and determine which of the renewable sources seem to have the most potential to alleviate energy problems. (Solar energy)

Renewable
Energy
Source

Comments

Solar
thermal
energy

Passive solar design: Architectural features for heating, cooling, and lighting, e.g., south facing glass; awnings that keep out sun during the summer; south-facing greenhouses; south-facing buildings; heavy insulation.
Active solar design: solar space and hot water heating systems use solar collectors and pumps or fans to move heated water and air through a building.

No supply, pollution, or safety problems.

Problems: How applicable is solar technology on a large-scale basis? One million homes and buildings in the U.S. now use some form of solar energy for water or space heating. (Source: Solar Energy Research Institute). Initial costs are high; tax credits are available for such systems.

Photovol-
taics

Photovoltaic solar cells convert sunlight directly into electricity without mechanical equipment. The solar cell is made up of thin layers of semi-conducting material that produce electricity when exposed to sunlight.

Problems: In order to serve as a significant replacement for fossil fuels, the cost of photovoltaic electricity must decline substantially. There are indications that this may happen. (See Sustainable Energy by Christopher Flavin and Rick Piltz with Chris Nichols, Renew America, Washington D.C., 1989)

Hydropower

In 1985, approximately 1,200 dams provided 65,000 megawatts of power, 13% of the nation's electricity, 5.5% of the total U.S. energy use.

Problems: Hydro projects often disrupt fish migration, inundate valuable forest and crop lands, alter ecosystems, and harm wilderness areas. Hydro development is only possible in certain geographic locations.

Geothermal

Comes from the heat contained in underground rocks and fluids. A form of geothermal energy -- hot dry rock technology, may be able to tap heat from underground rock formations in virtually any area.

Problems: Cuts in federal research programs have slowed the industry somewhat; only possible in certain geographic locations.

Biomass

Biomass is the material of which living organisms are composed.

.Wood fuel. In 1985 some 5-6 million homes relied entirely on wood for heating (i.e., fireplaces, wood stoves).

Problems: Excessive wood smoke in winter causes indoor and outdoor air pollution. Solutions: reduce smoke by using catalytic converters and/or clean-burning stove designs.

.Alcohol fuel. Ethyl alcohol (ethanol) is an alternative to gasoline. Ethanol is added to unleaded gasoline in a 10% mixture to yield "super unleaded with ethanol." Another alcohol, methanol, under proper conditions can be used in a vehicular engine. Both fuels may be used more extensively in motor vehicles as air pollution reduction is stressed and "Detroit" is asked to design cars for their use. Both fuels can be made from wood as well as grain.

Problems: Formaldehyde and other problem emissions must be overcome, although catalytic converters can control formaldehyde emissions when using ethanol.

Windpower Most large wind machines built so far require extensive repairs. When comparing windpower to conventional sources of energy, a cost-benefit analysis should be developed that takes into account the effects of each technology on the environment. Such an analysis may provide the political support needed to give wind energy a fair chance in the marketplace, e.g., through the restoration of tax credits and other public policy measures. See Energy Conservation Education: An Action Approach curriculum, pp. 53-55, for lessons on how a windmill works.

Ocean Thermal Energy Conversion (OTEC) OTEC relies on temperature difference between surface and deep water to vaporize and condense a working fluid that drives a turbine. May be widely used in tropical countries after turn of century. There are also wave and tidal energy technologies. All ocean technologies are currently in the research and development phase with no role in actual energy production expected in the near future.

(Source: Renewable Energy at the Crossroads, Center for Renewable Resources, now Renew America, Washington DC, 1985).

Followup: Ask the students to research in detail how passive and active solar energy systems work. See "Working with the Sun" sheet on Solar Space Heating in Auxiliary Materials, p. 34 to get started.

Lesson #2

Aim: To begin to plan the construction of the collector.

Motivation: Explain to the students that they could build a model solar collector to show other students how solar energy works. Show them the diagram in the Auxiliary Materials section on p. 30. If photocopying resources allow, distribute one copy to each student.

Discussion:

a. Discuss with the students the materials required by the can solar collector:

- 36 1-pound coffee cans (usually 6" in length, so 12 in each row will give collector tubes at least a 6' length, smallest size possible for optimal heating)
- 1 pint of flat black paint

--6'x3' of transparent plastic (or storm windows that will fit on collector)

--1 or 2 rolls of duct tape

--20 sq. ft. of 3/4" exterior grade plywood

--corkboard as insulation

b. Ask the students to suggest where any of these materials can be obtained.

Lesson #3

Aim: To continue planning for the collector and to develop a fundraising strategy.

Motivation: How can we raise funds for the supplies necessary to build the collector?

Discussion:

a. Lay out a fundraising plan with the class:

<u>Materials</u>	<u>Source</u> (Prices are approximate)
36 1-pound coffee cans	Students bring from home
1 flat black water-based paint	\$11 -- paint store
6' x 3' transparent plastic	\$4 -- paint/hardware store
1 or 2 rolls duct tape	\$5 -- hardware store
20 sq. ft. 3/4" exterior grade plywood	\$20 -- lumber yard, or school workshop at no cost to class
Cork as insulation	\$5 -- hardware store
Regular 3/4" nails	\$1 -- paint or hardware store
Small 1/4" nails	\$1 -- paint or hardware store
Wood lathes	\$5 -- lumber yard (or school workshop)

Approximate total cost -- \$52

b. Develop a list of fundraising sources from which to raise the necessary money to purchase those materials that are not donated. Fundraising sources could be the school alumni organization, P.T.A. or G.O., local banks, and/or area

merchants. Ask paint and hardware stores and lumberyard to contribute equipment first.

c. Begin work on a general fundraising letter to be sent to whatever sources the teacher, class and school administration feel are appropriate. See Part II, pp. 212-215, of the curriculum for section on developing a fundraising letter.

Followup: Ask each student to complete his/her version of the fundraising letter at home, or if completed in class, ask each student to then write his or her own letter.

Lesson #4

Aim: To implement the fundraising plan.

Motivation: Ask several students to read their version of the fundraising letter. Compare and contrast.

Discussion:

- a. Decide on a final version of the letter with the class.
- b. Make any final changes and ask a student to volunteer to type it.
- c. Determine the names and addresses of persons to be approached. Write to the head person of each organization to be approached.
- d. In the case of in-school organizations, assign students to hand-deliver letter to the recipient.
- e. Allow 2-4 weeks for final typing, editing, mailing, and response. A followup phone call one week after delivery or visit by teacher and/or students to potential fundraising sources may be advisable. See Fundraising section on pp. 212-215.

Lesson #5

Aim: To build the collector.

Motivation: Hopefully, some of the necessary funds or in-kind materials have been obtained. Arrange a trip to the paint or hardware store to purchase materials.

Discussion:

- a. The cans can be taped together to start the collector construction.
- b. Once all the materials are gathered, the construction can be completed in two class sessions. Again, see diagram in Auxiliary Materials section on p. 30.

Lesson #6

Aim: To demonstrate the operation of the collector to the class.

Motivation: Take the class outside on a sunny day to take temperature measurements. The collector and a thermometer are needed.

Discussion:

- a. Take measurements of air flowing into and out of the collector.
- b. Air temperature measurements can be taken while the collector is positioned at various angles in relation to the sun.
- c. What's the best angle for the collector to gather heat in the winter and summer?
- d. What are the basic means of heat transfer? (Radiation, conduction, convection)
- e. Under sunny conditions, this collector can heat air to well above 125 degrees F.

Lesson #7

Aim: To demonstrate the operation of the collector and solar energy to other students and teachers in the school.

Motivation: How can we educate others about solar energy and its potential importance?

Discussion (will take a few sessions):

- a. Discuss the idea of giving demonstration presentations to other classes (probably social studies and science).
- b. See Project A, Lessons 2 and 3, and the presentation section on p. 220.
- c. Develop outreach plan for the school. See Part II, pp. 209-211.
- d. Students need to study what they've learned about energy and solar energy to prepare for questions from other students.
- e. Demonstrating the collector may require taking classes and collector outside during a session, although the collector may be placed in sunny rooms too.

Followup:

*Is it possible for the class to build a collector which might be used to heat a small room in the school, or perhaps a room in someone's home in the community? If possible, the students could provide an important community service to low-income persons

struggling to meet their energy bills. While this may seem improbable, a can-type collector which fits into a south-facing window hooked up to some type of battery-run fan system to propel heat or air through the room might be feasible. We leave this to the inventors amongst you.

*Once students have organized an outreach campaign for the lighting conservation, and/or solar collector project, it may be possible to motivate the class or group to organize an "Energy Evening" for homeowners and tenants on how to conserve energy and cut costs. The same outreach techniques outlined above should apply, and speakers both from the now "expert" class, and/or from private and public energy organizations, may attract local residents.

*Student-organized letter-writing campaigns to local, regional, and national appointed and elected officials concerning programs and legislation aimed at reducing global problems like the greenhouse effect, acid rain, and deterioration of the ozone layer are other pathways for student activities. See "Letter-writing" section on pp. 230-238 and letterwriting projects in units on Water, Air, Noise, and Nuclear Issues.

ENERGY UNIT -- The Projects
AUXILIARY MATERIALS

1. Two charts and six worksheets for use in Project A, from Energy Conservation Education: An Action Approach, prepared by the Council on the Environment of New York City and New York State Energy Office, revised edition, 1983, Albany, New York.

2. Can Solar Collector for use in projects, taken from Energy Conservation Education: An Action Approach, op. cit.

3. Solar Water Heater Collector for reference, taken from Energy Conservation Education, op. cit.

4. "Working with the Sun" sheets for use in projects from Citizen Energy Information Packet, Council on the Environment of New York City, 1978. Sheets prepared by Leah Haygood.

DAILY ENERGY CONSERVATION LOG

School _____ Class _____

DATE	HOURS LIGHTS TURNED OFF	WATTS PER HOUR SAVED	TOTAL WATT /HRS. SAVED
Weekly Total in Watt /Hrs. Saved = _____		Weekly Total in Kilowatt/Hrs. Saved = _____	

School _____ Class _____

DATE	HOURS LIGHTS TURNED OFF	WATTS PER HOUR SAVED	TOTAL WATT /HRS. SAVED
Weekly Total in Watt /Hrs. Saved = _____		Weekly Total in Kilowatt/Hrs. Saved = _____	

School _____ Class _____

DATE	HOURS LIGHTS TURNED OFF	WATTS PER HOUR SAVED	TOTAL WATT /HRS. SAVED
Weekly Total in Watt /Hrs. Saved = _____		Weekly Total in Kilowatt/Hrs. Saved = _____	

School _____ Class _____

DATE	HOURS LIGHTS TURNED OFF	WATTS PER HOUR SAVED	TOTAL WATT /HRS. SAVED
Weekly Total in Watt /Hrs. Saved = _____		Weekly Total in Kilowatt/Hrs. Saved = _____	

School _____ Class _____

DATE	HOURS LIGHTS TURNED OFF	WATTS PER HOUR SAVED	TOTAL WATT /HRS. SAVED
Weekly Total in Watt /Hrs. Saved = _____		Weekly Total in Kilowatt/Hrs. Saved = _____	

School _____ Class _____

DATE	HOURS LIGHTS TURNED OFF	WATTS PER HOUR SAVED	TOTAL WATT /HRS. SAVED
Weekly Total in Watt /Hrs. Saved = _____		Weekly Total in Kilowatt/Hrs. Saved = _____	

Graphics courtesy of CON EDISON

KILOWATT HOURS WE HAVE SAVED SINCE

_____ (DATE)

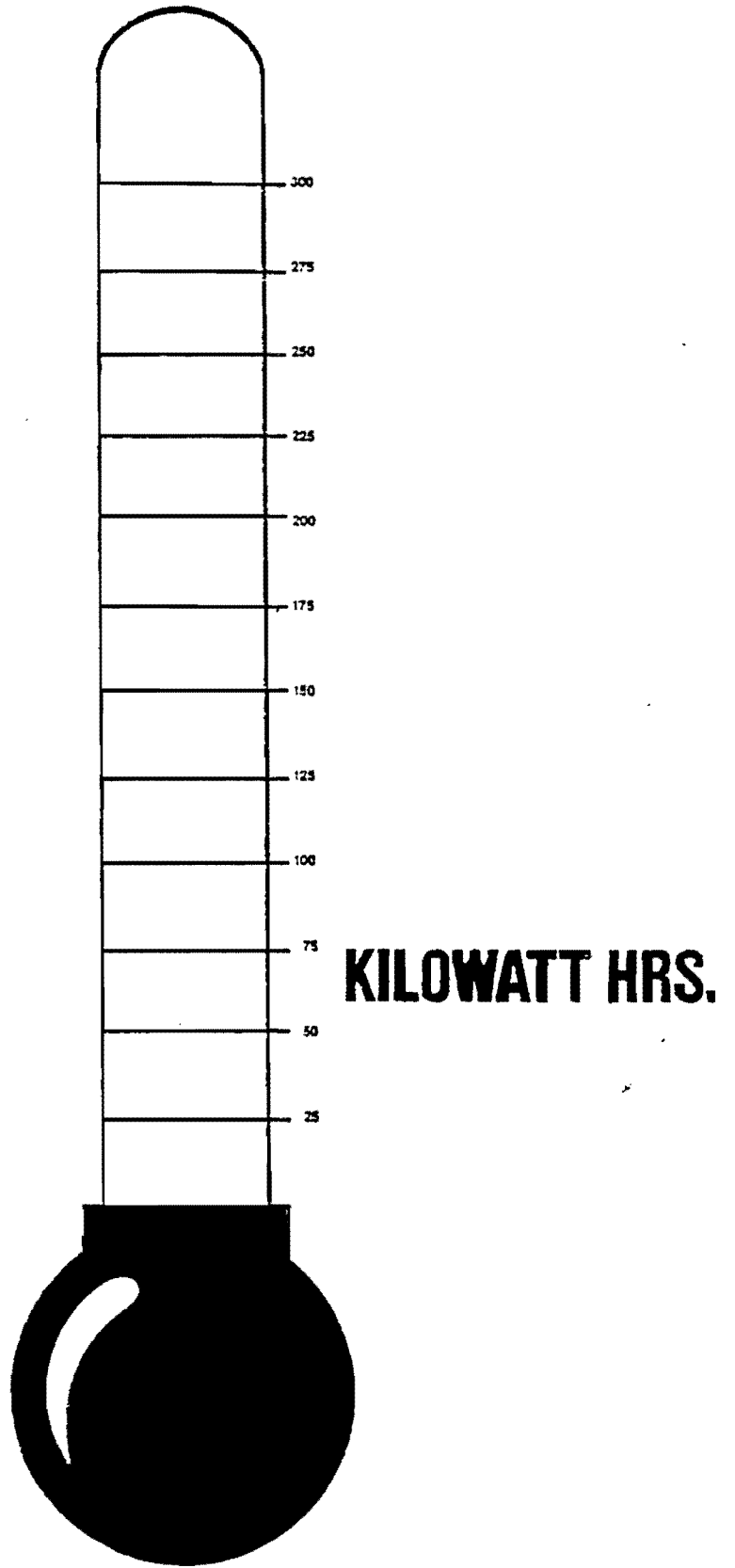

SCHOOL _____
CLASS _____

NAME _____
DATE _____

COUNTING WATT HOURS AND KILOWATT HOURS
IN THE CLASSROOM FOR A DAY, WEEK, AND YEAR

ENERGY CONSERVATION WORKSHEET A

1. How many rows of lights are in your classroom? _____
2. How many light fixtures in each row? _____
3. How many light fixtures are in your classroom? (A1 x A2) _____
4. How many light bulbs are in each fixture? _____
5. How many light bulbs are in your classroom? (A3 x A4) _____
6. If each fluorescent bulb is either 40 watts (4ft.) or 80 watts (8ft.), how many watts are there per fixture? (A4 x number of watts per bulb) * _____
7. How many watts** are there in all the fixtures in your classroom? (A3 x A6) _____
8. If each 40 watt (4ft.) or 80 watt (8ft.) bulb burns 40 or 80 watt hours each hour, how many watt hours does each bulb burn in a school day of 6 hrs? (6 x number of watts per fixture) _____
9. How many watt hours does each fixture burn in a school day? (6 x number of watts per fixture) _____
10. How many watt hours are burned during a 6 hour school day by all the fixtures in the classroom? (6 x A7) _____
11. If the number of kilowatt hours is arrived at by multiplying the number of watts by the number of hours used, and dividing by 1000, how many kilowatt hours are used by your classroom during a school day? $\frac{A10}{1000}$ _____
12. During a school week, when the lights are on 6 hours a day for 5 days, how many kilowatt hours are used? (5 x A11) _____
13. If there are 180 school days*** in a school year, how many weeks in a school year? $(\frac{180}{5} = 136)$ _____
14. How many kilowatt hours does one classroom use in a school year? (A12 x A13) _____

- * A1 means the answer to question 1 on energy conservation worksheet A; C5 would signify the answer to question 5 on energy conservation worksheet C. (A1 x B2), for example, means that it is possible to derive the answer to the present question by multiplying the answer to question 1, sheet A by the answer to question 2, sheet B.

- ** For incandescent lit classrooms in NYC the bulbs are usually 200 or 300 watts. Teachers outside the city will have to determine the wattages for their particular types of bulbs.

- *** Most school districts in New York State operate for approximately 180 school days a year.

SCHOOL _____
CLASS _____

NAME _____
DATE _____

SAVING ELECTRICITY IN THE CLASSROOM
AND SCHOOL FOR A DAY, WEEK, AND YEAR

ENERGY CONSERVATION WORKSHEET B

1. How many classes are there in your school? _____
2. In one day, how many kilowatt hours are used by all the classes in your school? (All X B1) _____
3. In one 5 day week how many kilowatt hours are used by all the classes in your school? (5 days X B2) _____
4. How many kilowatt hours do all the classrooms in your school use in a year? (180 days X B2) _____
5. If your class turned off 1/3 of the lights in your classroom for a day, how many kilowatt hours would be saved? (1/3 X All) _____
6. If your class turned off 1/3 of the lights in your classroom for a week, how many kilowatt hours would be saved? (1/3 X A12) _____
7. If your class turned off 1/3 of the lights in your classroom for the entire year, how many kilowatt hours would be saved? (1/3 X A14) _____
8. If every class in your school turned off 1/3 of its lights for a day, how many kilowatt hours would your school save? (1/3 x B2) _____
9. If every class in your school turned off 1/3 of its lights for a week, how many kilowatt hours would your school save? (1/3 X B3) _____
10. If every class in your school turned off 1/3 of its lights for a year, how many kilowatt hours would your school save? (1/3 X B4) _____

SCHOOL _____
CLASS _____

NAME _____
DATE _____

SAVING MONEY IN THE CLASSROOM AND SCHOOL
FOR A DAY, WEEK, AND YEAR

ENERGY CONSERVATION WORKSHEET C

1. If a kilowatt hour costs approximately 10 cents, how much does it cost to use the lights in your classroom for one day? (.10 X All) _____
2. How much does it cost to use the lights in your classroom for a week? (5 days X C1) _____
3. How much does it cost to use the lights in your classroom for a year? (36 weeks X C2) _____
4. How much does it cost to use the lights in all the classrooms in your school for one day? (.10 X B2) _____
5. How much does it cost to use all the lights in all the classrooms for a week? (5 days X C4) _____
6. How much does it cost to use all the lights in all the classrooms for a year? (36 weeks X C5) _____
7. If every class in your school turned off 1/3 of its lights for a day, how much money would the school save? (1/3 X C4) _____
8. If every class in your school turned off 1/3 of its lights for a week, how much money would the school save? (5 days X C7) _____
9. If every class in your school turned off 1/3 of its lights for a year, how much money would the school save? (36 weeks X C8) _____

SCHOOL _____
CLASS _____

NAME _____
DATE _____

SAVING ELECTRICITY AND MONEY IN THE SCHOOL DISTRICT
AND CITY FOR A DAY, WEEK, AND YEAR

ENERGY CONSERVATION WORKSHEET D

1. If every school in your school district (approximately 25* for NYC public schools) turned off 1/3 of its lights for a day, how many kilowatt hours would be saved? $1/3(25 \times B2)$ _____
2. If every school in your school district turned off 1/3 of its classroom lights for a week, how many kilowatt hours would be saved? (5 days X D1) _____
3. If every school in your school district turned off 1/3 of its classroom lights for a year, how many kilowatt hours would be saved?(36 wks X D2) _____
4. If every school in your school district turned off 1/3 of its classroom lights for a day, how much money would be saved? (.10 X D1) _____
5. If every school in your school district turned off 1/3 of its classroom lights for a week, how much money would be saved? (5 days X D4) _____
6. If every school in your school district turned off 1/3 of its classroom lights for a year, how much money would be saved? (36 weeks X D5) _____
7. If every school in your city (approximately 1000 public schools in NYC, for example) turned off 1/3 of its classroom lights for a day, how many kilowatt hours would be saved? $(1/3(1000 \times B2))$ _____
8. If every school in your city turned off 1/3 of its classroom lights for a week, how many kilowatt hours would be saved? (5 days X D7) _____
9. If every school in your city turned off 1/3 of its classroom lights for a year, how many kilowatt hours would be saved? (36 weeks X D8) _____
10. If every school in your city turned off 1/3 of its classroom lights for a week, how much money would be saved? (.10 X D8) _____
11. If every school in your city turned off 1/3 of its classroom lights for a year, how much money would be saved? (.10 X D9) _____

* Teachers should use whatever geographical or educational divisions and numbers are appropriate to their situation.

SCHOOL _____
CLASS _____

NAME _____
DATE _____

CONSERVING OIL IN THE CLASSROOM, SCHOOL
DISTRICT AND CITY FOR A DAY, WEEK AND YEAR

ENERGY CONSERVATION WORKSHEET E

1. Do you remember how many kilowatt hours are used by your classroom during a day? (see A11) _____
2. If one gallon of oil burning in a power plant produces about 11 kilowatt hours of electricity, how many gallons of oil are used by your classroom in one day? ($E1 \div 11$) _____
3. How many gallons of oil are used by your classroom in a week? (5 days X E2) _____
4. How many gallons of oil are used by your classroom in a year? (36 weeks X E3) _____
5. Do you remember how many kilowatt hours would be saved if every classroom in your school turned off 1/3 of its lights for a day? (see B8) _____
6. If every classroom in your school turned off 1/3 of its lights for a day, how many gallons of oil would be saved? ($E5 \div 11$) _____
7. If every classroom in your school turned off 1/3 of its lights for a week, how many gallons of oil would be saved? (5 days X E6) _____
8. If every classroom in your school turned off 1/3 of its lights for a year, how many gallons of oil would be saved? (36 wks. X E7) _____
9. If every school in your school district turned off 1/3 of its classroom lights for a day, how many gallons of oil would be saved? (In New York City, 25 public schools X E6.) _____
10. If every school in your school district turned off 1/3 of its classroom lights for a week, how many gallons of oil would be saved? (5 days X E9) _____
11. If every school in your school district turned off 1/3 of its classroom lights for a year, how many gallons of oil would be saved? (36 weeks X E10) _____
12. If every school in your city turned off 1/3 of its classroom lights for a day, how many gallons of oil would be saved? (In NYC 1000 public schools X E6) _____
13. If every school in your city turned off 1/3 of its classroom lights for a week, how many gallons of oil would be saved? (5 days X E12) _____
14. If every school in your city turned off 1/3 of its classroom lights for a year, how many gallons of oil would be saved? (36 weeks X E13) _____

SCHOOL _____
CLASS _____

NAME _____
DATE _____

CONSERVING COAL IN CLASSROOM, SCHOOL, DISTRICT,
AND CITY FOR A DAY, WEEK, AND YEAR

ENERGY CONSERVATION WORKSHEET F

1. How many kilowatt hours are used by your classroom during a day? (All)
2. If one pound of coal burning in a furnace produces about 1.3 kilowatt hours of electricity, how many pounds of coal are used by your classroom in a day? ($F1 \div 1.3$)
3. How many pounds of coal are used by your classroom in a week? (5 days X F2)
4. How many pounds of coal are used by your classroom in a year? (36 weeks X F3)
5. How many kilowatt hours of electricity would be saved if every class in your school turned off 1/3 of its lights for a day? (see B8)
6. If every class in your school turned off 1/3 of its lights for a day, how many pounds of coal would be saved? ($F5 \div 1.3$)
7. If every class in your school turned off 1/3 of its lights for a week, how many pounds of coal would be saved? (5 days X F6)
8. If every class in your school turned off 1/3 of its lights for a year, how many pounds of coal would be saved? (36 weeks X F7)
9. If every school in your school district turned off 1/3 of its classroom lights for a day, how many pounds of coal would be saved? (In NYC, 25 public schools X F6)
10. If every school in your school district turned off 1/3 of its classroom lights for a week, how many pounds of coal would be saved? (5 days X F9)
11. If every school in your school district turned off 1/3 of its classroom lights for a year, how many pounds of coal would be saved? (36 weeks X F10)
12. If every school in your city turned off 1/3 of its classroom lights for a day, how many pounds of coal would be saved? (In NYC, 1000 public schools X F6)
13. If every school in your city turned off 1/3 of its classroom lights for a week, how many pounds of coal would be saved? (5 days X F12)
14. If every school in your city turned off 1/3 of its classroom lights for a year, how many pounds of coal would be saved? (36 wks X F13)

CAN SOLAR
COLLECTOR

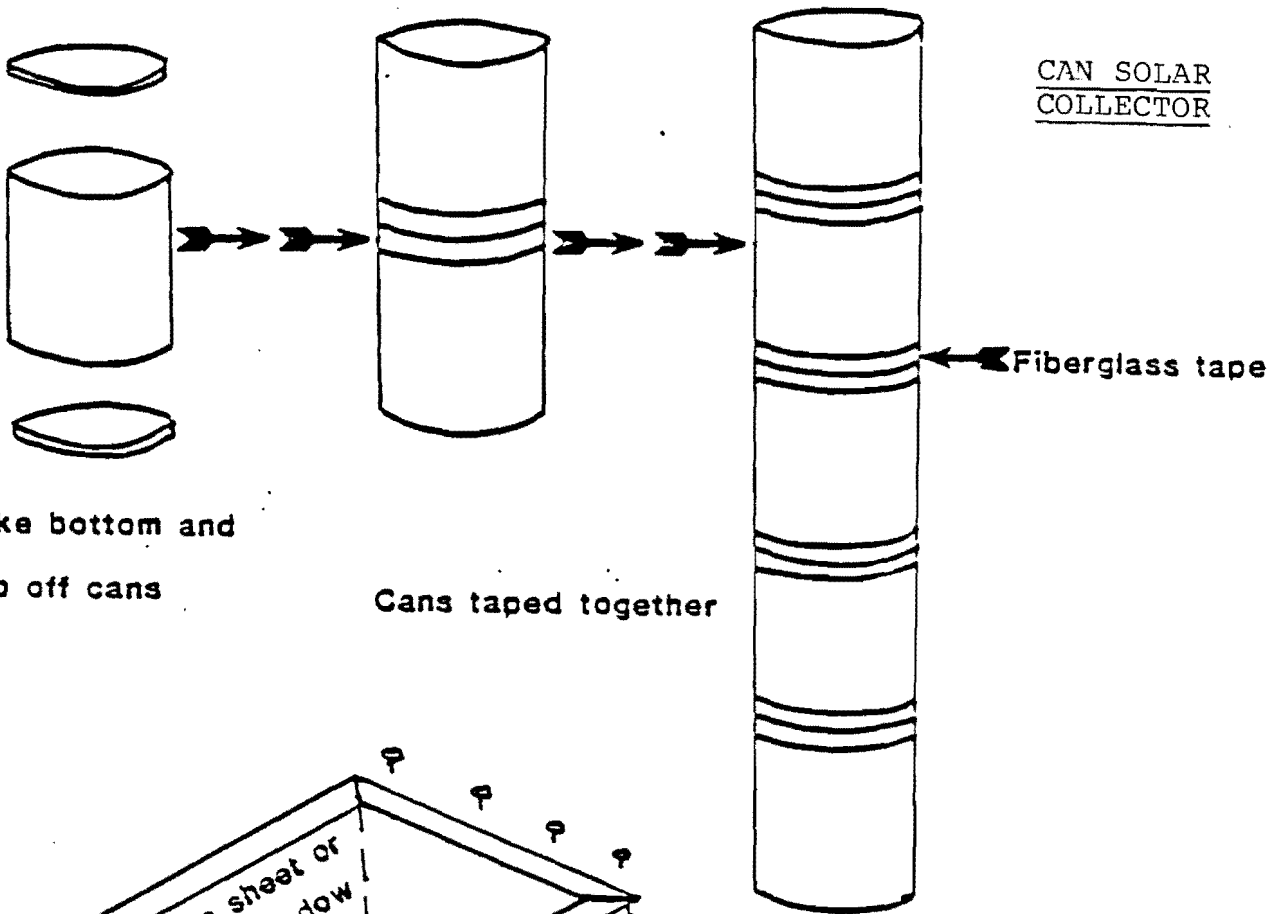

Take bottom and
top off cans

Cans taped together

Fiberglass tape

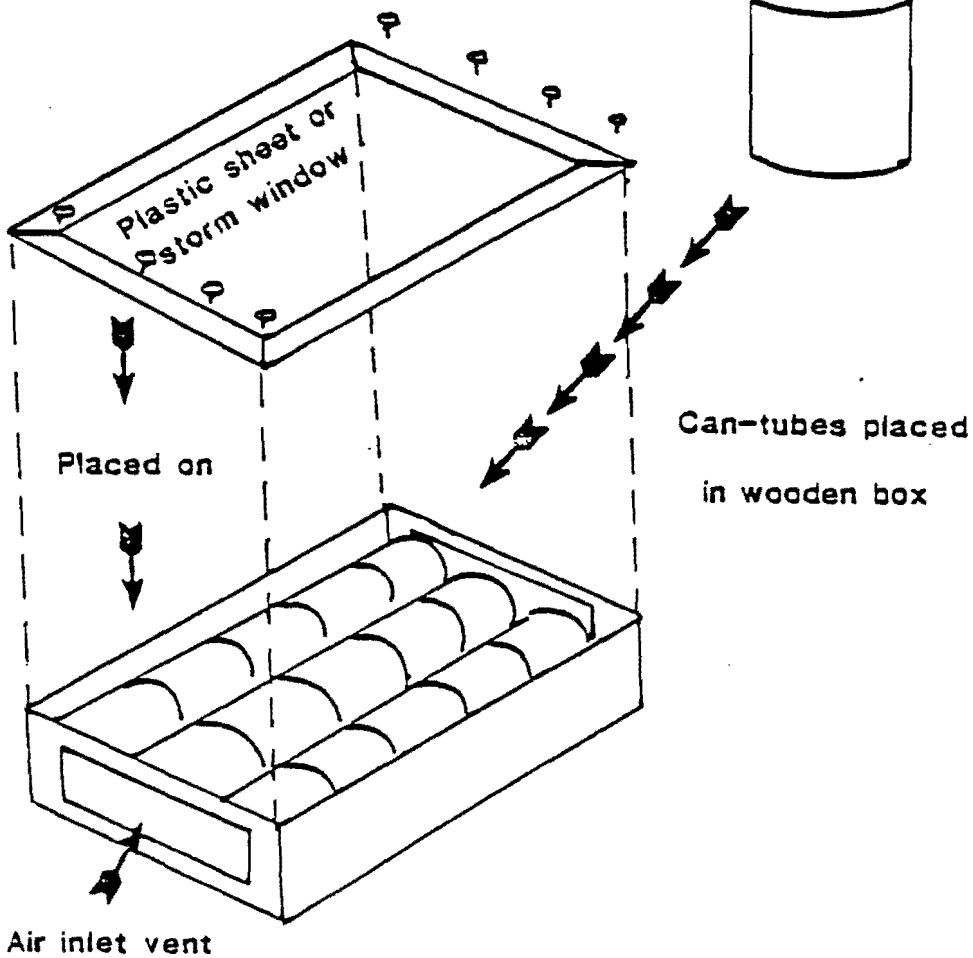

FIGURE 8A

Solar Water Heater Collector

There are several basic kinds of collectors made by a number of manufacturers.

This flat-plate collector consists of a black absorber plate which is heated by the sun's radiation. The heat is transferred through tubing to water running through the tubes.

Cross-section:

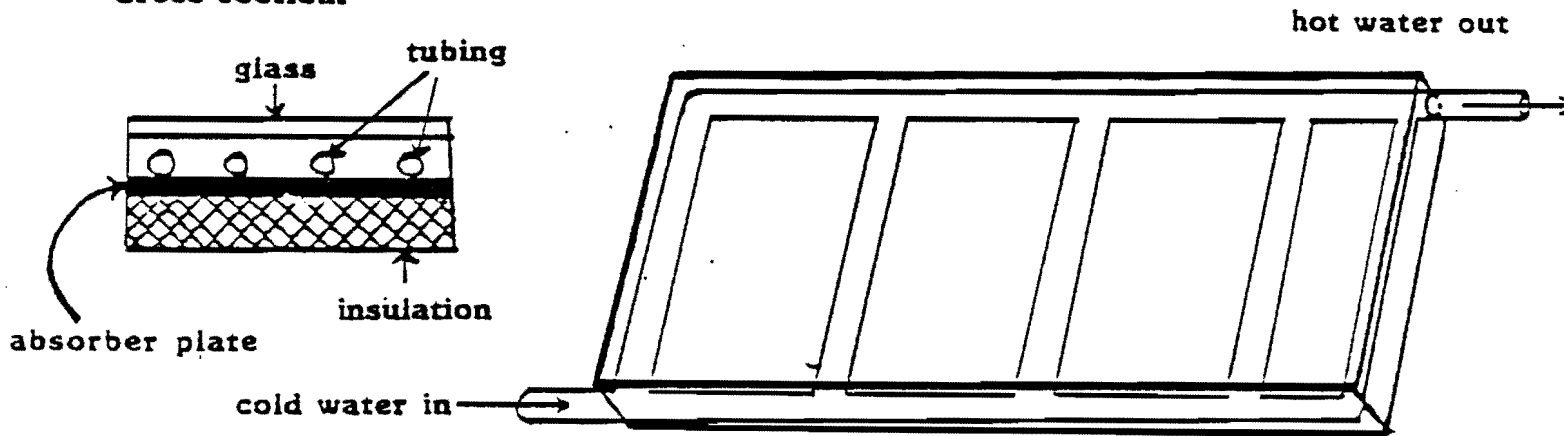
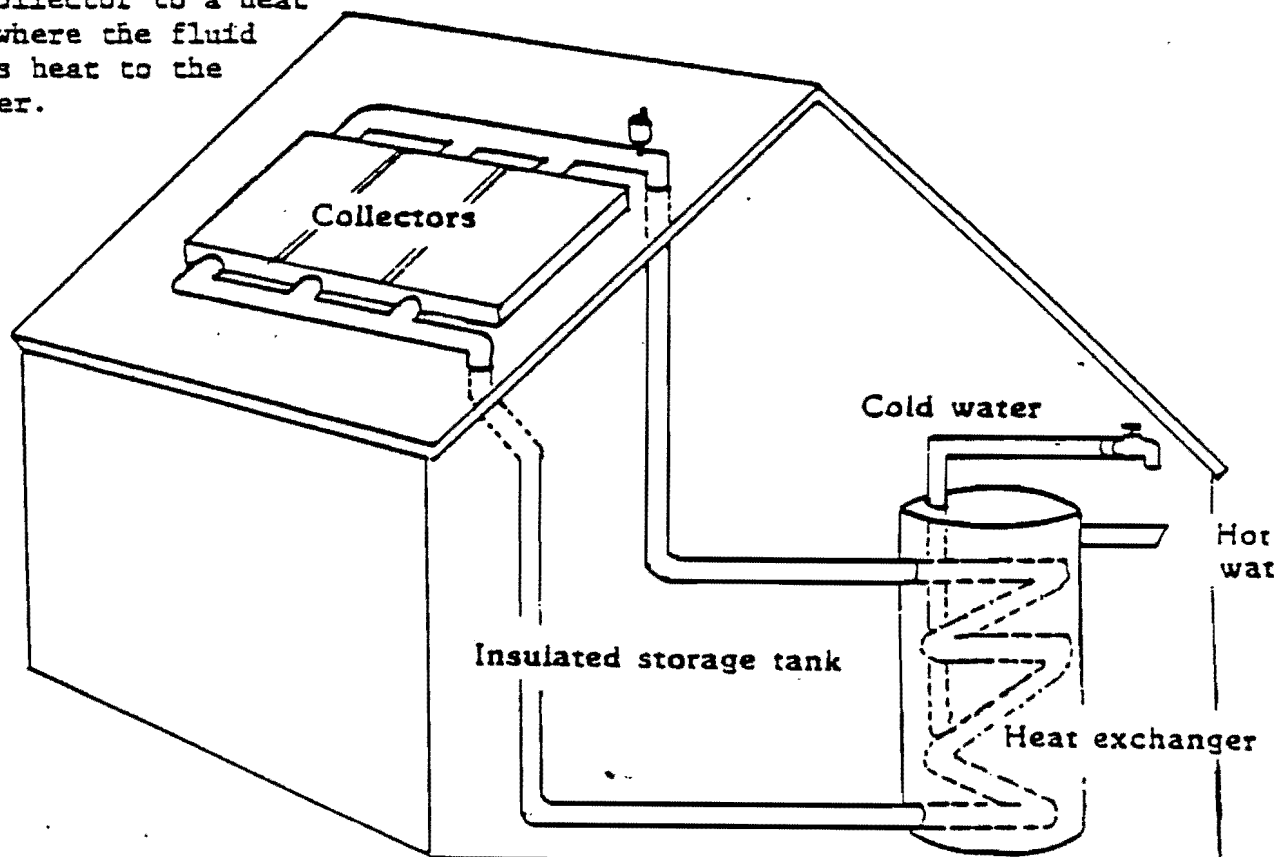

FIGURE 8B Closed Loop System

A closed loop system circulates a pressurized, nonfreezing heat transfer fluid through a collector to a heat exchanger, where the fluid gives up its heat to the potable water.



WORKING WITH THE SUN

Low-Cost Ways to Use Solar Energy in an Existing Building

A. Windows As Solar Collectors

Principle: Using south-facing windows to gain heat during the winter and to avoid gaining heat during the summer.

Way:

Overhangs which let in low-angle winter sun and exclude high-angle summer sun.

Example: On the shortest winter day in Philadelphia, the sun reaches a height above the horizon of only 26.6° , while on the longest day of summer, it reaches 73.5° .

Information from "solar position" tables.¹

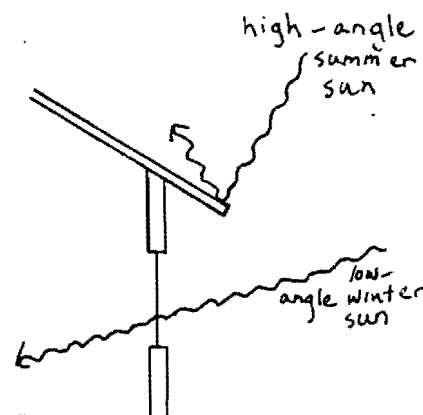

B. Preventing Heat Loss

Principle: Single-layered glass is excellent for collecting solar energy, but loses heat easily. For example, the heat loss from a 2' x 4' window is equal to the heat loss from a well-insulated 30' x 8' wall. To avoid heat loss, windows should be insulated when not collecting solar energy, i.e., at night and on cloudy days.

Ways:

1) Movable insulating shutters used on the inside of the window.²

2) Thick, insulating cloth held in place by velcro:

can be rolled up during the day.

Or,

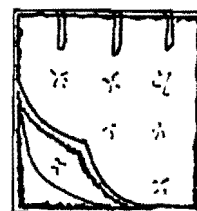

3) Design your own. Principles:

- . Material should have a high R-factor (a relative measure of resistance to heat loss). Example: High R-factors range from about 4 for an inch of corkboard to 30 for a very well-insulated wall (6" of insulation + vapor barrier + wall).
 - . Construction should allow a very tight fit into the window frame to prevent heat losses through leaking (air infiltration). There should be a space between the insulating material and glass. This "dead air space" provides insulation too.
 - . The devices should be easy to put in place and remove, so that you actually use them on cool nights and overcast days.
- 4) Most of the above devices require that someone be present to open or close, or put the device in place. When this is not possible, you can still keep a lot of heat from escaping through your windows by installing storm windows, or double- or triple-paned glass.³
- 5) Caulking and weatherstripping should be done, if necessary, in conjunction with any of the above.

Note: The overall level of insulation in your building is also important in preventing heat loss, whether the heat comes from the sun or an oil furnace. It is worth finding out where your heat losses are occurring (e.g. door) and insulating there. Always be sure to consider health hazards associated with the insulating material you use, and make sure that it meets federal standards for fireproofing.³

C. Storage of Collected Heat

Principle: Because the earth rotates on its axis, the sun's energy is not always available. So it is helpful to be able to store the sun's energy as heat. Two materials are commonly used, water and concrete.

Ways:

1) Water: One of the best storage materials for heat is water because it requires less space per unit of heat stored than most materials. When a new building is designed, there are many ways of using water, such as roof ponds, water walls, "drumwalls," etc.

For an existing building, dark-colored containers of water can be placed in the path of sunlight. The water will absorb and store the sun's energy as heat, releasing it when the room temperature is lower than the temperature of the water in the container.

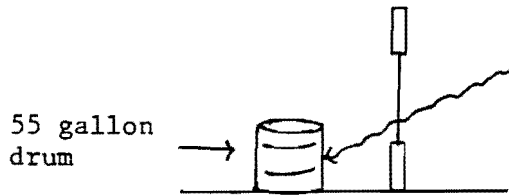

This method also helps to moderate room temperature during the summer, when the water absorbs room heat during the hot portion of the day (provided you have also used one of the devices previously mentioned to keep the summer sun from streaming in your window).

2) Concrete or masonry: These materials store less heat per volume than water, so a large amount, called "thermal mass" is needed. A large solid mass placed where sunlight falls will store heat. An example of this would be constructing a kind of indoor patio beneath a window.

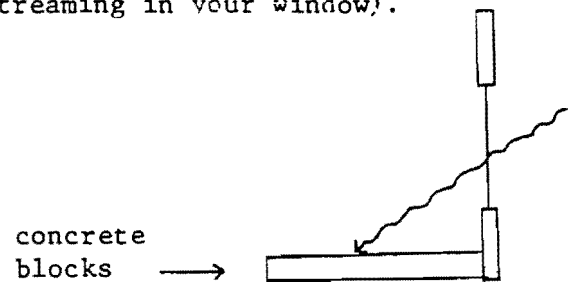

Note: Both water and concrete are very heavy, so before placing them on a floor, be sure that the floor can bear the weight.

INFORMATION

1 "Solar Position" tables are printed in The Solar Home Book by Bruce Anderson, Cheshire Books, Appendix 1. Also available from CENYC. Good sources of ideas for energy saving.

2 Information on insulating shutters can be found in a periodical called Alternative Sources of Energy. Ask for "Insulating Shutters" in Nos. 18 and 20, \$1.50 and \$1.75 respectively from Alternative Sources of Energy, Route 2, Box 90A, Milaca, Minnesota 56353.

3 Sources of information about weatherization (insulation and weatherstripping).

Making The Most Of Your Energy Dollars, U.S. Government Printing Office.
In The Bank...Or Up The Chimney? A Dollars and Cents Guide To Energy-Saving Home Improvements, Dept. of Housing and Urban Development, Washington, D.C.

WORKING WITH THE SUN

Solar Space Heating

Yes, city buildings can be heated with solar energy and yes, it works for buildings in northern climates, too. Certain types of city buildings are well-suited to solar heating because they can be well insulated. A good example is a three or four story building which shares two walls with buildings on either side (reducing heat loss) and lacks an airshaft. It is also important that the building receive sunlight on its walls or roof.

There are two basic approaches to solar space heating.

- A. Active solar heating uses mechanical systems to capture, store, and distribute heat, but these systems are very expensive still. Some solar space heating systems use air rather than water as the medium in the collectors. The air is either used directly to heat the desired area or is stored in large beds of crushed rock usually located in the basement.

The storage components for space heating can usually be used to heat water as well. An active solar system in a home in Waltham, Massachusetts provides 90% of its space and water heating needs over a year. A back-up heat source -- for example, oil, gas, electricity, or wood is generally needed during cold or cloudy spells.

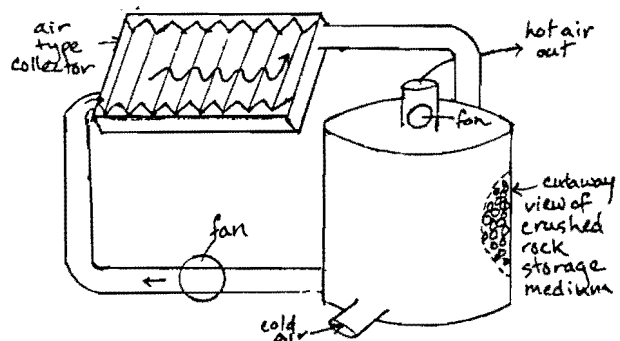

- B. Passive systems use the sun's energy directly: building walls and windows can collect and store the sun's heat and thereby warm the air inside the building. Hot air rises and causes the heat to circulate through the interior spaces; fans, ducts, and dampers are sometimes used to control the direction of the hot air.

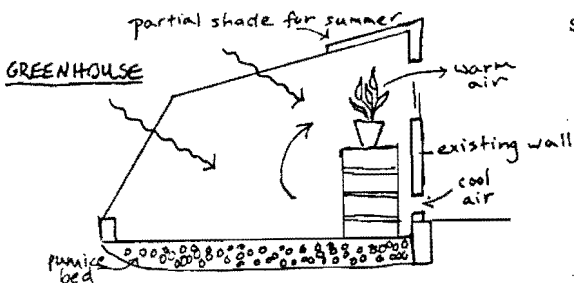

One way to add a passive solar heating system to an existing building is by constructing a greenhouse. The solar energy gathered by the greenhouse is stored in water-filled drums, heavy concrete blocks, or rock beds beneath the greenhouse floor.

Another way is to convert part or all of a south-facing wall of a building into a solar collector by painting it black, cutting two slits in it, and enclosing the exterior space with glass. The air in this space is heated and rises, moving into the house. Heat is stored by the walls, prevented from escaping by the glass and released to the interior when it is cooler than the wall.

There are many other ways to use passive solar heat. For a new building, the possibilities are nearly endless.

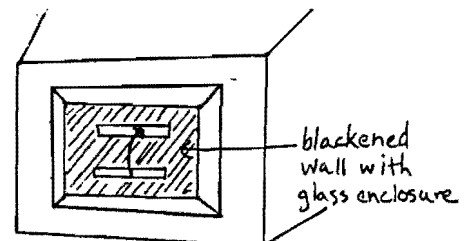

UNIT II: SOLID WASTE

Introduction

The majority of this country's solid waste goes to landfills, many of which will close in the next five to ten years due to lack of space and because they are health hazards.

Alternatives to landfilling are a pressing necessity. Incinerators pollute, are expensive, take years to build, and require a certain amount of garbage to be generated for them to be economical. Yet the massive amount of waste generated in most localities (28,000 tons per day in NYC alone) makes the construction of incinerators, which can handle large amounts of waste, seem inevitable. Most modern incinerators are high technology resource recovery plants that recover some metals and glass and convert organic wastes to energy. However, there is significant debate about the emission of dioxin and other pollutants during incineration, and about disposal of the ash material which results from the burning process.

Programs for low technology source separation (the setting aside of recyclable used materials in the home or workplace) can be implemented relatively quickly at less expense than high tech resource recovery plants. Such programs divert and market portions of the waste stream, reduce tonnage going to landfills, and cut municipal collection and disposal costs. However, fundamental problems remain. Can we motivate and/or mandate enough citizens to recycle on a large scale? Will there be markets for the materials collected? Will enough people and organizations demand and buy goods made from recycled materials? Debates continue as to how much of our garbage is recyclable, with estimates ranging from 25% to 75%.

Tax credits and favorable shipping rates have perpetuated the use of virgin rather than recycled materials in this country over the past twenty years. Because municipalities have begun to purchase increasing amounts of recycled materials, and due to the growing awareness of the finiteness of natural resources, the high cost of pollution in terms of health and dollars, and the dwindling spaces to dispose of such waste, much of what has been termed "garbage" in the past is beginning to be viewed as a resource. Jobs and new industry are resulting from separating recyclable materials from the waste stream and transforming them into usable commodities. The plastics industry, for example, is hard at work developing new uses for old plastic, polystyrene utensils and polystyrene trays. Amoco opened a plant in Brooklyn to recycle 500 used polystyrene trays daily from seventeen school cafeterias. The plant also accepts 300 pounds of mixed wastes from McDonald's restaurants each day. The plant produces a foam fluff that is nearly pure polystyrene. The material is eventu-

ally melted at another plant and reformed into pellets of polystyrene resin.^{3a} It remains to be seen, however, whether recycling plastics on a large scale will ultimately be possible.

Making goods from used materials is often more energy efficient and less polluting to our land, water, and air than creating these same goods from virgin materials.

Recycling is one way to reduce waste. There are many others, e.g., using the same string bags over and over again for shopping, producing minimally packaged goods, making goods that last a long time, refusing to buy disposable cameras and other items.

Solid Waste: The Issue

Lesson #1

Aim: To study solid waste problems and solutions.

Motivation: Empty a bag of garbage on top of a desk. Sort through it and categorize and tabulate its contents.

Discussion:

- a. What is solid waste and where does it come from?

Solid waste could simply be described as the discarded residues of the functioning of a society. America's municipal waste stream can be broken into ten categories. The categories are listed below with their approximate percentage of representation in the waste stream.

Paper and cardboard	37.1%
Glass	9.7%
Metals	9.6%
Plastics	7.2%
Rubber and leather	2.5%
Textiles	2.1%
Wood	3.8%
Food waste	8.1%
Yard waste	17.9%
Miscellaneous/other	1.9%

The United States produces 227.1 million tons of garbage a year, enough to fill one tower of the World Trade Center every day, or 187 World Trade Centers a year, or about 5.1 pounds per person per day. That is more garbage per person and per year than any other country in the world.

^{3a} Source: "Disposing of Man's Indestructible Resin: Polystyrene," Kathleen Meade, in Recycling Times, pp. 36-41, September, 1989.

b. What are the different means of waste disposal?

The three major means of waste disposal are landfills, incineration and recycling.

Landfill	87.1%
Incineration	7.0%
Recycling	5.0% ⁴
Other	0.9%

Landfills have been the preferred method for many years. However, many of them have reached or will soon reach maximum capacity. Many have been found to have toxic leachate that threatens the general populace by endangering underground drinking water supplies and/or other surrounding bodies of water. Some municipalities have begun to transport their solid waste to distant landfills in other states at great expense. Because of these factors, incineration (otherwise known as resource recovery) and recycling are receiving renewed consideration.

Followup:

Have students categorize and weigh their families' trash for a week. How do their percentages for the ten categories of waste compare to the national averages? Can they find ways to reduce their own and their families' contribution to the waste stream?

Lesson #2

Aim: What is resource recovery, and how does it work?

Motivation: How can incineration ease the solid waste crisis?

Discussion:

a. What is resource recovery? ⁵

Resource recovery is a means of waste disposal by which solid waste is incinerated and either steam or electricity is

⁴ Source of the statistics is Franklin Associates, as quoted in the Newsday series, "The Rush to Burn," 12/13-11/89.

⁵ Sources: National League of Cities, Combustion Engineering Inc., as quoted in the Newsday series, "The Rush to Burn," 12/15/89.

produced. There are two principal methods: mass burning, and Refuse Derived Fuel (RDF).

b. How does the mass burning process differ from the RDF process?

While both processes can be utilized to produce steam or electricity, there are significant differences between them. The RDF process involves the sorting of material. Trash is loaded onto a conveyor belt which carries the garbage into a shredding machine. Magnets remove metals from the trash. The metals are set aside for sale to a scrap dealer. The remaining trash passes through a series of screens that remove non-combustionable materials, such as gravel, dirt, sand, rocks and glass. These non-combustibles are taken to a landfill for disposal. The remaining material (about half of the initial volume) goes through another shredding machine to be smashed into small pieces. This material (called "fluff" RDF) is either sold to a utility as is, or is compressed into pellets or briquets ("densified" RDF) before being sold. Utilities burn RDF, sometimes with coal, to produce electricity.

Mass burning is exactly that - mass burning of solid waste. Garbage is burned for one second at temperatures of at least 2,000 degrees Fahrenheit, and then at temperatures of 1,500 degrees Fahrenheit or more for fifteen seconds. These high temperatures are supposed to destroy dioxin and other dangerous gases that may form from the burning of garbage. The burning trash heats water in a boiler to produce steam. This steam drives a turbine to produce electricity that is then sold to a utility. The resultant ash (about 10% of the garbage's original volume) is deposited in a landfill.▲

c. What are the problems of resource recovery?

While resource recovery provides some environmental benefits (reduction of dependence on landfills; energy production), there are a number of drawbacks. Resource recovery plants often operate on a volume basis -- the more trash, the better. Depending on what's in it, the ash that is produced may be highly toxic (possibly endangering to community health and underground water supplies). Plant emissions during the burning process may contain dangerous gases. If the plant goes out of service for mechanical reasons, provisions must be made for the disposal of accumulated trash.

▲ Some estimates of ash residue are much higher than 10%.

Followup:

* If possible, arrange for a class visit to an operating landfill or resource recovery facility.

* Have students research European waste disposal strategies (American resource recovery facilities are based on European disposal technologies).

Lesson #3

Aim: What is the role of recycling in solid waste disposal strategies?

Motivation: Can America develop a recycling ethic?

Discussion:

a. What is source separation?

Source separation is the separation of used materials at the point of usage before they become part of the waste stream. According to federal estimates, Americans recycle, at most, 10% of their garbage. In comparison, people in Japan and many countries in Western Europe recycle as much as 50% of their waste.

b. How does recycling work?

Experts recommend that the key to a successful recycling program is to keep it simple. Used materials, as seen in Lesson #1, can be separated into many categories. Used glass, paper, metals, plastics, and yard debris can be separated relatively easily before they enter the waste stream. Glass bottles and jars, after separation by color (green, amber and clear), are crushed and shipped to glass container manufacturers. The glass is melted and remade as glass bottles. Paper is taken to paper mills or de-inking plants. Paper is then soaked and turned into a liquid called slurry. Paper fiber is washed free of ink and compressed between rollers to remove water from the slurry. The fiber can then be reprocessed to make newsprint, paperboard, and other paper products. Aluminum cans can be crushed and made into cans or other aluminum products at an aluminum smelting plant. Steel cans, after being crushed or shredded, are taken to de-tinning plants to remove the tin. Leftover iron can be sold to scrap metal dealers for recycling. Plastics can be shredded or melted and recast as construction materials, tape and many other materials. Plastic bottles, for sanitary reasons, cannot be reused as bottles, but can be remade into other products. Yard wastes can be recycled by composting and used as organic fertilizer and ground cover.

Recycling reduces garbage, saves natural resources, stimulates citizen participation in environmental improvements, and makes money for those involved.

c. What are the problems with recycling?

Although recycling would certainly be effective in reducing America's dependence on landfills and incinerators, there are several problems that must be overcome. There is a need to develop a market for products made with recycled materials. People and organizations must demand such products. Manufacturers will then produce them. Unless products made from recycled materials can compete with products made with virgin materials, consumers, manufacturers and scrap dealers will have no incentive to buy or sell recycled and recyclable products.

Mass burn resource recovery plants may compete with recycling centers for combustible materials such as paper. Paper provides an excellent fuel for incinerators and can provide the burning temperature these facilities require.

Massive educational efforts must be made to overcome the apathetic attitude of a consuming, convenience-minded society. Americans need to develop a sense of responsibility and accountability for a problem that was previously "out of sight, out of mind."

Followup:

* Arrange for a class trip to a landfill or a recycling plant.

* Students can develop (with the assistance of school custodians and kitchen staff) a school-wide recycling program for such materials as metal, glass, and plastic (from the cafeteria) and paper (from classrooms and offices). The students can explore the development of markets for recycled products with waste haulers, manufacturers, and local business leaders.

* Students can develop a campaign to eliminate (or at least reduce) the use of disposable plastics in the school cafeteria.

* Students can study the recycling efforts of Japan and Western Europe and present oral reports to the class.

* Students can research and suggest means of reducing packaging.

* Have students discuss the problem of litter, which plagues many U.S. cities and countries all over the world. What creates the problem of litter?

- ▶ Carelessness
- ▶ Negative feelings about the area we live in
- ▶ Inadequate receptacles
- ▶ Excessive packaging

► The "waste ethic"

Solid Waste: The Projects

A. Organizing a Neighborhood Cleanup/Sweep

Lesson #1

Aim: To briefly discuss litter as a part of the garbage/solid waste problem.

Motivation: Ask the students whether they feel litter is a problem in their city or town. If so, why?

Discussion:

- a. What creates the problem of litter? (See last section of issue section.)
- b. What can be done about litter? (organized cleanups, education of citizens, Bottle Bills, more garbage baskets, etc.)
- c. What should we do about litter in our neighborhood?
- d. Explain that a sweep or a cleanup is often a good way to start an anti-litter effort; the sweep motivates people to participate, gives them a "feel" for their streets, and demonstrates concern publicly while highlighting the litter issue locally.
- e. As a followup, ask students to think about how they'd go about organizing a cleanup.

Lesson #2

Aim: To plan the sweep.

Motivation: Have any of you thought about how you would organize a cleanup in the school you are in or in your own neighborhood? (Sweep will probably focus on neighborhood around the school, but could focus on an area where many students live if they are so motivated. Logistical problems could be difficult if area is far away from the school.)

Discussion:

- a. Let's use this organizing model:

Issue: Solid Waste/Litter --> Project

<u>Strategy</u>	<u>Method</u>
-----------------	---------------

Service and direct action	Sweep
---------------------------	-------

b. Let's consider these factors about the sweep?

Where should we sweep?	Which streets/areas?
When should we hold the event?	5-7 weeks from this session-- weekday or weekend?
Who should be involved?	See Outreach Plan in this curriculum, Part II, pp. 209-211.
What materials are needed?	Brooms, shovels, bags, gloves.
How can we obtain materials?	Local Sanitation Dept. might be helpful.

c. What agencies do we have to inform about the event? (School administration, local community groups, community board or town council, Sanitation Department, police if street closing is needed or parking has to be curtailed.)

d. How should we approach these groups and individuals we want to involve? (Letter, flyer, posters, presentations. See Part II.)

Followup: Assign some interested students to develop a few different versions of a basic publicity flyer for the event. (See Part II, pp. 205-208)

Lesson #3

Aim: To continue planning and organizing the event.

Motivation: Let's look over the flyers you've done at home.

Discussion:

a. Look over and analyze the flyer with students and choose a final version. Make arrangements to have it drawn by artistic students in the class or by students from the art department.

b. Discuss with class how many copies are needed and how they will be printed (in school or using student-developed resources, e.g., a local bank).

c. Discuss whether posters are needed and if so, how flyer design can be utilized on the bigger poster and how the poster will be drawn and duplicated.

d. Also discuss the idea of giving brief presentations to other classes and/or arranging interviews with teachers to motivate student participation in the cleanup. (Here and throughout this project, see Part II on presentations, flyers, outreach plan, etc.)

e. What will go into such a presentation? (Slides, handouts, ideas to be presented.)

f. Determine those classes, groups in neighborhood, etc. who will receive flyers, be given a presentation, etc. Which students will do what. In other words, develop the outreach plan.

Followup: Ask the students to prepare a presentation on the sweep, to be role-played in the next class session.

Lesson #4

Aim: To practice a presentation to other students on the sweep and finalize the outreach plan.

Motivation: Who would like to role-play their presentation on the sweep? Would a group like to share the practice presentation?

Discussion:

a. Have the students practice and comment upon the presentation. Those not presenting can play students in the class targeted for the talk. (The actual final talk should not be more than ten minutes in each class and should end with some flyers being distributed to the teacher and interested active students in each class.)

b. The role-play may take an entire session, but at some point the class should finalize the outreach plan and individual assignments.

c. It may not be feasible to give presentations in all classes; some teachers may need to be approached individually.

d. The individual contact and/or presentation approach can be used to approach appropriate block associations to enlist their participation.

Lesson #5

Aim: To implement presentations and outreach (four weeks).

- a. Give presentations.
- b. Invitations should be sent to local officials to solicit their participation.
- c. Press releases should be written and sent to newspapers, radio, even local TV to obtain publicity. This may motivate more participation in the event, but more importantly will highlight the issue in the area and pave the way for future efforts (see TSO curriculum, Part II, section on press releases and publicity, pp. 197-198 and 202-204).

Followup:

* Evaluate the sweep in terms of quality and quantity of participation, immediate effort, etc. (See Evaluation section in Part II, pp. 225-229.)

* If a full sweep is not possible with a particular class a teacher is working with, or because of administrative factors, a demonstration sweep in which students in the class are the primary participants is possible. This can still educate the school and community and highlight the litter issue.

* Plan for future activities to develop a full-range anti-litter campaign: more sweeps, litter patrols, workshops and/or flyers for store owners on sweeping regulations, anti-litter signs on stores and in public places, recycling projects, etc. See following projects.

B. Organizing an In-School Anti-Litter Campaign

Lesson #1

Aim: To briefly discuss litter as a part of the garbage/solid waste problem.

Motivation: Ask the students whether they feel litter is a problem within their school and the immediate school grounds.

Discussion:

Follow discussion in Lesson #1, Project A in this unit. Focus on an in-school space as the area for a campaign. The in-school anti-litter project could start with a sweep or poster campaign.

Lesson #2

Aim: To plan the anti-litter campaign.

Motivation: What should an anti-litter campaign in the school be comprised of?

Discussion:

a. Lesson should be fairly similar to Lesson #2, Project A in this unit, except that materials will be obtained from school custodial staff in most cases. Contacting other outside agencies will probably not be necessary.

b. Determine whether the campaign will be participatory, i.e., sweeps or similar activities including other students; whether the organizing class will do a demonstration sweep or publicity type campaign involving, for example, posters and additional litter cans placed throughout the school.

Followup:

Same followup as Lesson 2, Project A, except students should probably work on posters.

Lesson #3

Aim: To develop an outreach plan and practice presentations to other students (if an initial participation activity which involves more than a demonstration cleanup by the organizing class is included).

Motivation: Look at posters students have developed.

Discussion:

a. Develop outreach plan and practice presentations; see Lessons #3 and 4, Project A in this unit.

Lesson #4

Aim: To implement the project strategy and method (1-2 weeks).

Motivation/Discussion:

a. Posters go up in school either asking for participation in cleanup or urging students not to litter, or both.

b. See that new litter baskets are put in place.

c. Presentations to other classes or at an assembly should be given.

Lesson #5

Aim: To continue implementation and assess the project.

Motivation/Discussion:

- a. Presentations go on.
- b. Sweep or other event carried out.
- c. Assess success of effort in school -- is there less litter? More concern about the issue in school?
- d. Combine in-school activities with sweep outside the school.

Followup: Use in-school effort to start neighborhood cleanup drive.

C. Organizing a Survey/Report on Neighborhood Commercial Street Sanitation

Lesson #1

Aim: To briefly discuss litter as part of the garbage/solid waste problem; to discuss commercial street litter as part of this problem.

Motivation: Ask the students whether they feel litter in front of stores, restaurants, etc. is a problem in their city, town or neighborhood, and if so, why?

Discussion:

a. Follow discussion in Lesson #1, Project A in this unit. Focus on commercial streets as arena for concern. What are the locality's rules for store owners with respect to street sweeping, tying garbage, etc.? What are the problems commercial establishments face in keeping their streets clean?

b. Discuss possibility of a survey of commercial street litter as a means of learning more about the problem and recommending changes, e.g., more litter baskets on certain streets, that could be made by the local sanitation department or local businesses.

c. How would we go about developing such a survey?

Followup: Take the class on a walk/trip to some possible areas that would be suitable for the survey to observe and take photographs of different litter conditions on the streets. Photos could be used in Lesson #3.

Lesson #2

Aim: To begin planning the survey.

Motivation: Have any of you thought more about how we would go about conducting a commercial street sanitation survey?

Discussion:

a. Let's use this organizing model again:

Issue: Solid Waste/Commercial
Street litter --> Project

Strategy

Education; Political
action; Service

Method

Survey and report to
government officials
on commercial street
litter

b. How would we determine the extent of commercial street litter in a given area?

c. Through discussion come to an understanding that by actually counting litter on targeted streets the class can get an idea of the commercial litter problem in that area.

d. Lay out an area for observation around school and/or where students live after consulting the local sanitation department, community board, town council, etc.

Lesson #3

Aim: To continue planning the survey.

Motivation/Discussion:

a. Develop a street litter rating system for sources and for cleanliness. See p. 55 in the Auxiliary Materials section at the end of Projects part of this unit.

b. Use photographs of actual commercial street litter to teach students to apply rating scale of sidewalk cleanliness and evaluate sources of litter.

c. Assign students blocks (a two or three square block area) to rate from the target area.

Lesson #4

Aim: To continue planning the survey.

Motivation/Discussion:

a. Take students out during the regular class session either to a commercial street or to a street near school to practice rating litter conditions on streets.

Lesson #5

Aim: To conduct the survey.

Motivation/Discussion:

a. Students can do the survey on class time if feasible, or else they can rate their assigned areas on their own time.

Lesson #6

Aim: To collect data and collate report.

Motivation/Discussion:

a. Start to put report together in a manner similar to the FDR report in Auxiliary Materials section which follows. Assign students to finish writing, computing, and typing after class.

Lesson #7

Aim: To develop outreach strategy to disseminate and publicize report.

Motivation: What agencies and/or officials should receive our report?

Discussion:

- a. Develop list of agencies and officials to send report to.
- b. Prepare a cover letter for the report and send it to those on the list
- c. See Part II, pp. 197-198 and 202-204 for instructions on how to prepare a press release and a publicity strategy. Remember: Publicizing the report can highlight the commercial street sanitation issue.

Followup:

* Have students gather names and addresses of appropriate editors/reporters at all pertinent newspapers, radio stations,

etc. that the report is to be sent to. Send report with the press release.

* Continue to track the report to see if it is used by the local sanitation or public works department. The report could be used by the town/city officials to reassign litter basket pickups, establish litter patrols, etc.

D. Organizing a Small Recycling Project

Lesson #1

Aim: To discuss the solid waste issue.

Motivation: What do we mean when we say that many cities in the U.S. are facing a "garbage time bomb?"

Discussion:

a. Using the Introduction and Issue section in this unit as a backdrop, begin a discussion with the students about the problems communities face in disposing of their garbage.

b. Discuss amount of garbage, contents, the available options for disposal, and alternatives for the future.

c. What are the pros and cons of low technology source separation and high technology resource recovery programs?

d. What about the public health consequences of the high tech incinerators and the possible inability of local government to dispose of garbage in the future?

e. What are some ways to reduce the amount of garbage? Recycling, using the same string bag again and again, not buying products in individual containers or wrapping, etc.

f. Can all materials be recycled? Are there markets? Can more be recycled than is currently being recycled?

g. What are the benefits of recycling and how will large scale recycling help defuse the "garbage time bomb?"

h. Do people want to recycle?

i. Do people want to reduce the amount of trash?

Lesson #2

Aim: To discuss specific types of recycling projects.

Motivation: Make a list of all the materials in this classroom that are recyclable.

Discussion:

a. How many of these materials are commonly recycled today? (Paper, glass, metals, etc.)

b. Which materials are not often recycled although it could be possible to do so? (Cardboard, leather or other textile goods that make up clothes, etc.)

c. What percentage of plastic products are recycled nationwide?

d. Are there any materials that may not be recyclable at all or only if handled very carefully? (For example, some toxic chemicals or laboratory equipment that contain hazardous waste material.)

e. Explain to the students that there are programs in many parts of the country to recycle paper, aluminum cans and newspaper. Nine states have "Bottle Bills" which allow consumers to get a deposit back for returning their soda and beer bottles and cans. Many localities and municipalities in the country have mandatory recycling. NYC is mandated to recycle 25% of its waste by the mid 1990s.

f. How would a recycling project in this community help the garbage problem? If the school and residents are already recycling some materials, consider collecting other materials.

g. What type of recycling project would be realistic in this school and/or community?

Followup: Ask the students to develop a chart of possible materials not being recycled in the school or neighborhood, but which could be recycled and the advantages and disadvantages of each material with respect to availability, storage, marketability, safety, etc. Is it realistic to recycle plastics in general; what about in the school environment?

Lesson #3

Aim: To do initial planning for a recycling project.

Motivation: Discuss the charts the students have prepared of available materials and their feasibility for recycling.

Discussion: Use the usual design to crystallize the project:

Issue: Solid Waste/
Recycling --> Project

<u>Strategy</u>	<u>Method</u>
Service Direct action	Recycling Project or Center

a. What should we collect? Where should the program be, in the school, neighborhood, or both? Where can we store materials? Who will buy the materials?

b. If there is no "Bottle Bill" in the state, and they are not already being collected separately, then aluminum cans are usually an available, safe material for collection which can be sold to Reynolds, Alcoa, or some middle-level collector for a fair price. They can also be recycled by the school through the "Bottle Bill" mechanism. Newspapers are plentiful and most people will respond to a call to recycle them, but storage and safety (they can be a fire hazard) are problems, as is the recent very low price for newspaper, which makes it difficult to arrange for the paper to be picked up or stored elsewhere. Glass can yield huge tonnage, but there are storage and safety problems too. Glass is bulky and breaks easily. Collecting white ledger paper is easily integrated into school life, but it is difficult to generate enough paper to motivate a carter to pick it up, unless the local Sanitation Department is a partner in the process.

c. It will probably be best to begin the recycling project with the school population, motivating teachers and students to participate and arranging for storage with the school custodian. Community residents can be invited to participate by bringing recyclables if this is realistic.

d. Begin to develop an outreach plan. See Part II, pp. 209-211, for development of an outreach plan.

Followup:

* As in Project A, Lesson #2 in this unit, have some interested students develop a few different versions of a basic publicity flyer for the recycling project

* Committees on outreach, publicity, collection and space should be set up and each committee should begin to make necessary contacts and develop the materials needed to get the project going.

Lesson #4

Aim: To continue planning for the recycling project.

Motivation: Let's finalize our plan for a recycling project/center.

Discussion:

a. Review or finalize decision as to what materials to collect and market, target populations, storage space, etc.

b. Discuss whether organizing should lead toward a full-fledged recycling center in the school, a smaller project which might not involve community residents or the whole school population, or a one-day, week, or month campaign.

c. Who will collect the materials in the school and tie them, bag them, etc., during what hours or on what days? When will the project start? Should the organizing class do all the necessary planning and arranging, or should other student volunteers be solicited?

d. How should the teachers and students (and community residents if applicable) be informed about the project? Should flyers be distributed and presentations given to each class or at an assembly?

e. See this unit, Project A, Lessons #3, 4 and 5.

Lesson #5

Aim: To implement recycling project plan.

Motivation/Discussion:

a. Review all aspects of previous two lessons to make sure that everything is being accomplished.

outreach plan for flyer distribution and presentations developed, etc.?

c. If presentations are to be given, practice them during one or more class sessions. Presentations should be brief (5-10 minutes) and informative, dealing with the reasons for recycling and instructions for recycling the material properly.

Lesson #6

Aim: To continue the project implementation.

a. Presentations (if being given) should be practiced and given according to the outreach plan.

b. Flyers should be distributed by presenters and in other areas throughout the school.

c. A single one-day event can be developed to start actual recycling; prizes can be given.

d. Evaluation of storage system, amount being recycled, student participation, and so on should be done on a weekly basis.

See Part II for Evaluation.

SOLID WASTE UNIT -- The Projects

AUXILIARY MATERIALS

1. Section from FDR High School Commercial Street Sanitation Report, May 1983.

I EVALUATION OF SIDEWALK CLEANLINESS

Background

Each of the students chose a two block stretch of a commercial street near their home. Those living in the general vicinity of F.D.R. High School were encouraged to choose a section of 13th Avenue, 18th Avenue, or Church Avenue lying within the boundaries of Community Board #12.

The students' first task was to assess how clean (or dirty) their chosen blocks were. The City of New York, through the Mayor's Office of Operations, uses a system called "Project Scorecard" to measure street and sidewalk cleanliness. This system requires the evaluator to give a street one of seven different ratings, by comparing it to a set of photographs illustrating each point on the measurement scale. Use of this system is somewhat difficult and requires training from "Project Scorecard" staff. Also, this measurement system focuses primarily on curbside litter, which can sometimes be difficult to assess because of parked cars.

Rating System Used

A simpler system was developed for rating the cleanliness of sidewalks in local commercial areas. This system requires the evaluator to count the pieces of litter (defined as "anything bigger than a matchbook") in front of each store or other building. He or she must also decide if the building front being assessed is of average width (12-15 feet). Once this decision is made, one of the following three ratings can be assigned to each store or building front:

1. Clean: 4 or less pieces of litter per storefront (or per 15 feet of sidewalk).
2. Fair: 5 to 10 pieces of litter per storefront (or per 15 feet of sidewalk).
3. Dirty: 11 or more pieces of litter per storefront (or per 15 feet of sidewalk).

One class session was devoted to training students in the use of this system. Photographs were used to demonstrate the different ratings, and to test students in the use of these ratings.

This evaluation system had both benefits and drawbacks. On the positive side, the evaluator can simply count litter and does not need to make subjective judgments. On the other hand, it may have been difficult for some students to make the necessary judgment of a storefront's width, although most storefronts in the F.D.R. area are about 15 feet wide. In addition the rating system did not account for variations in sidewalk width (from building line to curb); however there appears to be only slight variation in sidewalk width among the commercial blocks rated.

Data

Each student rated their two block section twice; these on-site ratings were performed two weeks apart. Students entered their rating for each store or other building onto maps which they prepared. Once all the ratings had been made, a class session was devoted to tabulating this data, and students arrived at a composite score for each of their blocks.

Table 1 presents these scores, divided between blocks inside the Community Board 12 area (C.B. 12) and those outside of this area. In a few cases two students rated the same blocks, but at different times. In these cases each student's composite scores are reported separately, but the numbers for "Student 1" and "Student 2" were averaged into a single "block rating" for arriving at an average for the entire shopping street.

Conclusions from Data

A few points can be made, based on the data in Table 1. First of all, on the whole the shopping areas examined by students did not vary greatly. For both inside and outside the Community Board 12 area, average scores ranged around 1.7, indicating a fair or moderate level of sidewalk litter, with somewhat more clean storefronts (4 or less pieces of litter) than dirty ones (11 or more pieces of litter). Among shopping streets within C.B. 12, Table 1 indicates that the main shopping blocks of 18th Avenue may be somewhat cleaner than 13th Avenue or Church Avenue. Also, as Table 1 indicates, for 13th Avenue (the largest shopping strip in C.B. 12) the section between 40th and 50th Streets is substantially cleaner than the section between 50th and 60th.

Table 1: Sidewalk Cleanliness Ratings: Composite Scores

1 = Clean: 4 or less pieces of litter per storefront
 2 = Fair: 5 to 10 pieces of litter per storefront
 3 = Dirty: 11 or more pieces of litter per storefront

A. Inside Community Board 12 Area

<u>13th Avenue</u>	<u>Student 1</u>	<u>Student 2</u>
37th to 38th	1.7	2.2
38th to 39th	2.5	2.3
39th to 40th	1.6	
40th to 41st	1.5	
43rd to 44th	2.1	
44th to 45th	1.8	
45th to 46th	2.0	
46th to 47th	1.8	
47th to 48th	1.4	
48th to 49th	2.0	1.6
49th to 50th	1.8	1.7
50th to 51st	1.5	
51st to 52nd	1.5	
52nd to 53rd	1.5	
53rd to 54th	1.2	1.6
54th to 55th	1.3	1.7
57th to 58th	1.3	
58th to 59th	1.2	
59th to 60th	1.9	
60th to 61st	2.5	
Average for 40th-50th	1.77	
Average for 50th-60th	1.48	
Average for 13th Avenue	<u>1.72</u>	

Church Avenue

Chester to Story	2.3
Story to Dahill	1.8
McDonald to E. 2nd	1.6
E. 2nd to E. 3rd	1.5
E. 4th to E. 5th	2.0
E. 5th to E. 6th	1.8
E. 6th to E. 7th	1.7
E. 7th to E. 8th	1.5
Average for Church Ave.	<u>1.78</u>

Table 1 (continued)

<u>18th Avenue</u>	<u>Student 1</u>	<u>Student 2</u>
McDonald to 45th	1.4	
45th to 46th	1.4	
46th to 47th	1.4	
47th to 48th	1.8	
57th to 58th	1.8	
58th to 59th	2.1	
59th to 60th	1.7	
60th to 61st	1.5	1.4
Average for 18th Avenue (within C.B. 12)	<u>1.63</u>	
Average for Inside C.B. 12 (13th, Church, & 18th)	<u>1.71</u>	

B. Outside Community Board 12 Area

<u>18th Avenue</u>		
61st to 62nd	2.0	
63rd to 64th	1.7	1.7
64th to 65th	1.8	1.8
<u>5th Avenue</u>		
56th to 57th	2.0	
57th to 58th	1.7	
58th to 59th	1.2	
59th to 60th	1.1	
<u>8th Avenue</u>		
48th to 49th	1.8	
49th to 50th	1.9	
<u>Avenue N</u>		
Flatbush to E. 46th	2.0	
E. 46th to Schneckady	1.5	
<u>86th Street</u>		
Bay 24th to 20th Ave.	1.7	
20th Ave. to Bay 25th	1.9	
<u>Utica Avenue</u>		
Eastern Pkwy. to Union St.	2.1	
Union St. to President St.	1.7	
Average for Outside C.B. 12	<u>1.74</u>	

II SOURCES OF LITTER

Background

To fully understand neighborhood sanitation, and to begin to think about strategies for improving neighborhood cleanliness, it is important to consider the sources of litter. The idea for systematically examining the sources of litter comes from the diagnostic work of the organization "We Care About New York." However the specific factors we examined were determined through class discussion, after the students had become familiar with the unique problems of their shopping areas, and had read Department of Sanitation pamphlets dealing with the City Health Code and sanitation regulations.

Evaluation System

Students were asked to spot actual occurrences of littering, dumping, and garbage spillage. In addition they looked for situations where sidewalk litter could easily result, due to improper or inadequate containment of garbage. The categories used in this evaluation were:

Possible Sources

- A. Overflowing Public Trash Baskets: receptacles, provided by the City or a community organization, which are filled beyond the brim.
- B. Overflowing Private Dumpsters (large metal containers on wheels).
- C. Overflowing Private Cans and Boxes: boxes and small cans with garbage spilling out.
- D. Open or Broken Private Trash Bags (awaiting collection)
- E. Untied Refuse: specifically, loose boxes or papers awaiting collection.

Actual Sources

- F. Person Littering: person dropping a small amount of litter on the sidewalk or street.
- G. Person Dumping: discarding a bag or large quantity of trash in a public space or public receptacle.
- H. Garbage Spilled by Sanitation Workers (during collection)

For this evaluation, students examined a four block section of a shopping street; this included the two blocks they evaluated earlier, for sidewalk cleanliness, and an adjoining two blocks. In some cases, two or more students evaluated the same blocks, but this was generally done on different days. Class members were instructed to do this "sources of litter evaluation" on two separate days, at different times of the day (including one morning visit) entering their field observations onto a special form. A class session was then devoted to tallying each student's data.

Data and Conclusions

Table 2 shows the total number of actual or possible sources of litter observed by all the students in the class. A general conclusion that can be drawn from the data in Table 2 is that different parties share responsibility for the sidewalk litter problem.

a. Sanitation Department Responsibility. An important task performed by the Sanitation Department is the emptying of city trash baskets, provided for the use of pedestrians. If these baskets are not emptied frequently, two problems can potentially result: garbage can easily blow off of the top of the basket, and pedestrians may litter due to the unavailability of a useable trash can.

In drawing maps of their assigned blocks, students had indicated the location of all public trash baskets. On the whole, these blocks were well provided with baskets. Within the Community Board 12 area, an average shopping block has about three City trash baskets; in some cases this is supplemented by one or more baskets provided by a local organization.

As Table 2 indicates, students noted a substantial number of overflowing public trash baskets. An especially large number were observed on 13th Avenue between 37th and 42nd Streets. Focussing on all of the C.B. 12 data, 49 overflowing baskets were seen by 19 students examining four blocks on two separate occasions. This breaks down to an average of one overflowing basket on any single visit to a four block area. It should also be noted that a few of these baskets are provided by community or merchants groups, and must be emptied by these groups. All in all, the sanitation department seems to be doing a fairly good job of servicing its trash baskets but more frequent pick-ups would be an asset.

Table 2: Tabulation of Sources of Litter Data

<u>type</u>	<u>number of times observed</u>		
	<u>within C.B.</u> <u>(19 students)</u>	<u>outside C.B.</u> <u>(7 students)</u>	<u>total</u>
A. Overflowing Public Baskets	49	17	66
B. Overflowing Dumpsters	79	24	103
C. Overflowing Private Cans	99	35	134
D. Open/Broken Bags	62	38	100
E. Untied Refuse	119	26	145
F. Littering	32	19	51
G. Dumping	4	-	4
H. Trash Spilled by Sanitation Workers	1	1	2

b. Merchant and Building Owner Responsibility. Students had read City regulations and looked at photographs relating to proper and improper disposal and containerization of private trash. In evaluating their shopping areas they looked for the following violations: overflowing dumpsters, overflowing private trash cans, open or broken bags, and untied refuse. These violations do not only create unsightly conditions but are a potential source of litter in that garbage can easily be scattered due to such improper disposal methods.

The data clearly indicates a high number of each type of violation, primarily on the part of merchants. Numerous storekeepers clearly do not have an adequate number of containers (dumpsters or trash cans) for the amount of garbage they generate. In addition, merchants using trash bags are frequently using them improperly, and merchants putting out boxes and papers are often not flattening and tying them adequately.

While it is difficult to estimate how much merchant violations contribute to the litter problem on commercial streets, it is clear that more cooperation from merchants is needed. Possibly storekeepers need to be better informed about sanitation regulations; this could be accomplished through periodic education campaigns. In addition existing enforcement, carried out by sanitation officers with assistance from civilian sanitation patrol members, may need to be increased in specific areas.

c. Pedestrian Responsibility. The most obvious source of litter is the passing pedestrian who negligently drops a piece of trash. As Table 2 indicates, a moderate number of individuals (51) were seen littering. In assessing this number, it must be kept in mind that students were looking for 8 different types of problems, and it is much easier to notice an overflowing trash basket or untied refuse than to spot someone littering. However class members witnessed a good deal of littering, including a substantial amount of garbage thrown from car windows.

Students were asked to indicate the approximate age of any person observed littering. An understanding of who litters is helpful in designing a strategy for litter control. Most students were able to make this age estimate, and the information gathered was broken down into three age categories:

<u>estimated age of litterer</u>	<u>number observed</u>
child: 12 years or under	7
teen: 13 to 21 years	14
adult: 22 years of older	16

Based on the data collected, it seems that all age groups contribute to the litter problem in C.B. 12 and adjacent areas. There is some indication that children and teenagers together may create a disproportionate amount of litter. One thing this suggests is that anti-litter efforts should, whenever possible, reach out to and involve youth.

REFERENCES

Disposal and Recovery of Municipal Solid Waste, Michael Henshock, Butterworth, Boston MA 1983.

Garbage in the Cities: Refuse, Reform and the Environment 1880-1980 by Martin V. Melosi, College Station, Texas: Texas A & M University Press, 1981.

Garbage: Our Endangered Planet, Karen O'Connor, Lucent Books, San Diego CA, 1989, 72 pp.

Garbage: Practices, Problems and Remedies, Allen Hershkowitz, et al., Inform, New York, 1988, 32 pp.

Refuse to Burn, Robert W. Lockersby, Vance Bibliographies, Monticello, NY, 1986, 17 pp.

The Solid Waste Handbook, Wiley, New York, NY, 1986, 848 pp.

UNIT III: WATER

Introduction

Whether a municipality gets its water from a municipal or regional surface water source (lake, river, or reservoir) or from an underground storage area (well or aquifer), or from both, the health and well-being of the residents depend upon the maintenance of an adequate and healthy supply of water. Localities must conserve to preserve an adequate supply of this precious resource for everything from drinking to fire safety and keep the quality of any particular water resource appropriate to its intended use. In parts of the world where the population must consume polluted water, life expectancy is low and infant mortality high. It is estimated that worldwide at least 15 million children below the age of five die each year in developing countries. The lack of safe water and sanitation is a major cause of this. If all humans had access to safe water and sanitation, infant mortality would be cut 50% worldwide.⁶ Eighty per cent of all sickness and disease in the developing world can be attributed to unsafe water and inadequate sanitation.⁷

Custodians of water supplies must be concerned about preventing and/or controlling pollutants, whether they are farm animal and other agricultural wastes that are washed into a reservoir or feeder stream by river run-off, sewage produced by humans in their habitats in and around the surface or underground water supply, or industrial/commercial discharges. Proper planning and care are important in minimizing these impacts, e.g., efficient sewage treatment utilizing primary and secondary stage of treatment with disinfection, restrictions on use of pesticides and household hazardous chemicals, and pretreatment of industrial waste. These measures reduce the possibility of water-borne infectious diseases such as cholera, typhoid and dysentery, chemical and heavy metal contamination, as well as aesthetic displeasures in taste and odor.

Public health scientists and government officials can disagree about the specifics of water quality, maintenance and planning. Some public health scientists contend that current means of purifying waters (sewage treatment, disinfection, filtration) are not enough to guarantee 100% high quality user-safe water. Protection of public health suggests the limiting of any development that would pollute drinking water supplies rather

⁶ Taken from UNICEF estimate in Decade Dossier, International Drinking Water Supply and Sanitation Decade, 1981-1990, UN Development Programme, New York.

⁷ Water and Sanitation for Health: Toward the Year 2000, United Nations Development Programme, New York, New York.

than depending on filtration plants to remove pollution after the fact. Some government agencies feel that we can re-use water once polluted by building large filtration plants to treat the water. However, it is important to recognize that these plants are new, experimental, and can only function to their constructed capacity -- and at a cost of millions of dollars to taxpayers. Even if filtration is utilized, most public health scientists agree that it is important to prevent as much pollution as possible from entering a drinking water supply so as to not overburden the filtration facilities.

Only 1% of the world's water is potable; 4% is fresh water that is frozen in glaciers in the North and South Poles and the other 95% is in the oceans and unsuitable for drinking unless desalinated. The majority of the 1% of the potable water is not in surface supplies, but underground, collected from rain water and seepage from the earth's surface and located below the surface in underground aquifers. This underground water has taken millennia to accumulate and cannot be quickly replaced once it is used or polluted. This groundwater flows to the surface in places and is in lakes, rivers, streams and many reservoirs. It is essential to public health, safety and well-being that this water supply be protected by conservation, care, education and rationally-minded planning and development along with time-proven methods of wastewater treatment and disinfection.

Water quantity as well as quality is a concern. Largely in the West and South, dams have rerouted the water and enabled agriculture and cities to exist in areas that without this water could not have tolerated such growth. In older cities, water supply systems are often critically in need of repair, which requires large amounts of capital. Drought and an inadequate supply makes water an intense political issue in many localities. (The Latin root of the English word "rivalry" is "rivus," a brook; "rivalis" is someone living near or using the same stream as another person.)

Protection of recreational and commercial waters is another related problem. After water is used for varied human purposes, the resultant wastewater is often treated in sewage treatment plants before being discharged into lakes, streams, oceans, rivers etc. Water quality depends on what is poured down the drain and discharged from homes and businesses, on the maintenance of an adequate sewage treatment plant system with the capacity for at least secondary treatment of wastes, on the pretreatment of industrial wastes, and on the proper handling and disposal of that inevitable by-product of sewage treatment -- sludge. The treatment of toxic chemicals and metals that find their way into our waters is insufficient for safety. Many chemicals and heavy metals cannot be treated at sewage treatment plants. More needs to be done to protect these essential waters.

Water: The Issue

Lesson #1

Aim: To understand where our water comes from, and how it is used.

Motivation/Discussion:

a. Have the students discuss where they think their water comes from and what some different water uses are. (See Hydrologic Cycle Diagram in Auxiliary Materials section after Projects.)

b. Show the students a map and/or pictorial representation of the water supply system used in their area. Usually the local Department of Environmental Protection, Water Supply or Public Works has one. Point out the method of transporting the water (i.e., gravity flow, aqueducts, electrically powered pumps, etc.). Discuss the technology used for the system and if another method of transport is feasible. What are the land uses in the area where the water travels (i.e., urban, suburban, agricultural, forest, etc.) How much water does the system supply on a daily basis? How much does the system hold overall?

c. For example, New York City consumes approximately 1.6 billion gallons of water per day, about 250,000 more than the safe field for the system. The water is obtained from three reservoir systems: the Croton, the Catskill and the Delaware.

The Croton: consists of 12 reservoirs and supplies approximately 10% of NYC's daily water needs. Construction of the original Croton supply system was completed in 1842, although the system has undergone many changes and expansions since; the watershed spans part of Putnam, Dutchess and Westchester Counties. A filtration plant will be built for Croton water because of the impact on the water quality of intense development in these counties.

The Catskill: consists of two reservoirs and supplies up to 40% of the city's daily needs. The system, built from 1905 to 1927, is located approximately 125 miles from the city limits. Development is steadily increasing in the Catskill watershed.

The Delaware: is the largest of the three systems. It was built from 1936 to 1964, includes three reservoirs, and accounts for 50% of the city's daily water needs. Development is also increasing in the Delaware watershed.

The system holds 550 billion gallons and operates almost entirely by gravity.⁸

d. This discussion could ensue for any drinking water supply in any part of the country. With a supply that comes directly from groundwater, leaching of toxins from landfills, industry, and homes is a concern and should be discussed. With a supply from rivers, streams and reservoirs, discuss adverse impact of residential and industrial development and land use in the watershed.

e. Make a list of the different ways you use water every day and record the amount of gallons you use in these activities. Use this guide as a reference:

Toilet flush	5-7 gallons; 1-1/2 gallons with a low flush toilet
Shower (15 minutes)	20-30 gallons; less for a shorter shower especially with a low flow fixture on showerhead
Washing dinner dishes for four people	10-20 gallons

Followup:

Tell the students to record how many times their dishes are washed at home (with a machine or by hand), the shower is used, and the toilet flushed within a 24-hour period. The next day in class, total up the amounts of water used for each family, the class, and make estimates for the school, city, or town.

► Should we use this much water everyday? How do reservoirs refill themselves?

► Discuss the hydrologic cycle (again, see diagram). Rain seeps down and is stored in sedimentary rock layers below the earth's surface, or falls in a surface water area such as a lake, river or stream. Some of this surface water evaporates (is changed into vapor by heat), is soaked up and stored in clouds until the clouds cool and rain or snow (precipitation) is produced. Plants add to the cycle by transpiring water (which they gather from leaves and roots), giving it off in the form of vapor or gas to the clouds which store and re-use the vapor.

⁸ Source: NYC Department of Environmental Protection Information sheet and Thirsty City: A Plan of Action for New York City Water Supply, Citizens Union Foundation, 1986.

Lesson #2

Aim: To understand how sewage treatment plants function to reduce water pollution.

Motivation/Discussion:

It's always best to let students experience a system first-hand and this is particularly so with sewage treatment, a difficult subject to discuss in the abstract. A trip to a local wastewater treatment facility is advisable, or at the very least, a slideshow on how such a facility works. Usually the local environmental, water, or public works department can and will help you arrange a trip or slideshow.

a. Handouts like the ones in the Auxiliary Materials section can help.

b. Stress should be placed on the significant advances made in public health due to modern sewage treatment (see text of handout in Auxiliary Materials section).

c. Emphasize that sewage treatment plants treat much of the wastes (not chemicals and heavy metals) that we produce and discharge via toilets, showers, wash basins, etc. Try to point out where the wastes from students' homes go. In the case of NYC, treated wastewater is discharged into the harbor and rivers; the sludge currently goes to the Bight, a site 106 miles offshore. The City will have to find a new solution to the sludge problem in the next two years.

d. Distinguish between wastewater and solid waste/garbage; although the two can mix to some degree due to factors like storm runoff, illegal dumping, and disposable diapers, they are mostly separate wastes dealt with through separate disposal systems.

e. Primary sewage treatment is a mechanized process which removes about 35% of both organic and suspended solids.

f. Secondary treatment, a biological process using bacteria to decompose organic wastes, removes 70-90% of organic and suspended solids.

g. Tertiary treatment uses chemical or biological treatment processes to further decontaminate water; however, secondary treatment is often adequate when effluent is to be discharged into a fishable (where you can catch but not necessarily eat the fish) and swimmable open waterway. Few systems in the United States have tertiary treatment which is very expensive.

h. Chlorination disinfection, or ultra-violet light treatment should be used to remove the remaining 10% of organic

matter if the secondary treated water is discharged into streams or rivers that feed a public drinking water supply.

i. The primary concept here is that sewage treatment plants are essential to protect drinking water supplies and commercial/recreational open waters. As such plants do not treat many toxic chemicals and heavy metals, it is better for people not to discharge such hazardous substances into the system.

j. Sewage treatment plants need to be maintained and operated properly in order to efficiently perform their functions.

Followup:

Notes on Septic Tanks

In areas where there is no comprehensive sewer/sewage treatment plant system, the most common type of subsurface disposal system includes a septic tank and an absorption or leaching field. The tank serves to store settled and floating solids and the leaching field serves to distribute the effluent so that it can percolate through the soil. As with sewage treatment plants, septic systems do not treat toxic chemicals and metals. Decomposition of organics takes place under anaerobic conditions.^{8a}

Lesson #3

Aim: To discuss the natural and built elements of the environment surrounding our drinking water supply.

Motivation/Discussion:

a. List the natural aspects of the area surrounding a drinking water supply: forests, rivers, streams, animals, wetlands.

b. How does each impact on the water supply, e.g., trees store water that they eventually release into underground aquifers from which drinking water is drawn directly or that feed storage reservoirs; surface rivers and streams flow into reservoirs and sometimes receive waste from agricultural, residential and industrial runoff, sewage treatment plants, etc.

^{8a} Source: Basic Environmental Technology: Water Supply, Waste Disposal and Pollution Control, Jerry Nathanson, John Wiley & Sons, 1986.

c. What are the man-made elements in the watershed: homes, roads, cars, farms, businesses, sewage treatment plants, etc.

d. What is the impact of these elements? Homes and businesses produce wastewater; salt put on wet, slippery roads is washed into the streams, lakes, rivers and reservoirs as is oil from autos, fertilizers, pesticides, and animal wastes from farms; sewage treatment plants treat wastewater and deliver their effluent into streams, rivers, lakes, and reservoirs.

e. How can the watershed area be protected? Discussions here could cover the idea of limiting development to the extent that wetlands (see the following lesson) are protected, and new homes, industry, shopping facilities, roads, etc. are built only if they are connected to adequately sized and functioning sewage treatment plants; also that homeowners and commercial enterprises not discharge toxic chemicals and heavy metals.

Lesson #4

Aim: To learn about the importance of wetlands in protecting drinking water and open water supplies.

Motivation/Discussion:

- a. Ask if any students know what a wetland is.
- b. Wetlands are lands covered by water for at least part of the year, for example, swamps and marshes.
- c. Wetlands have several important functions. For example, they provide habitats for many species of birds and animals, help to control floods, and filter out pollutants from streams, rivers, lakes and land.
- d. Are there any wetlands near the school?
- e. What happens when we build something on a wetland?
- f. It is important to protect wetlands to provide a haven for birds and animals, and to protect drinking water supplies. Building on wetlands can destroy habitats and damage the wetland's filtering ability.

Followup:

* This lesson is a brief introduction to wetlands. A slideshow of wetlands and/or a field trip to a nearby site will help bring the subject to life for students, youth groups, etc.

* The issue of wetlands protection and development is a complex one. Obviously, a growing population needs residential and industrial development; however, wetlands are essential natural purifiers and habitats which help maintain precious ecosystems. A balance needs to be struck: wetlands that protect drinking water or serve as a home for endangered species should be protected;

other less strategically important ones may sometimes be used for development.

* If it hasn't already been done, a class trip to a reservoir or sewage treatment plant at this point can help the overall water issue come alive to students.

Lesson #5

Aim: What is the impact of acid rain on water supplies?

Motivation: Obtain some pH paper from the science lab and use it to test rainwater collected in clean glass beakers by you and the students. Also test tap water.

Discussion:

a. How does rain, snow, etc. become acidic? (Sulfur and nitrogen oxides from power plants and motor vehicles combine with precipitation.)

b. What are some of the effects of acid rain on lakes and surrounding vegetation? Increase of acidity from the rainfall leads to a decreasing of pH in a lake resulting in a removal or leaching out of metals and minerals from the soil and sediment of the lake bottom and the shoreline areas, which poison aquatic life. In forests, the acidified rain removes minerals and nutrients from the soil which are used for food by plants. Plant life thus decays. Some symptoms of those occurrences are: large amounts of fish kills on the lake or shore area, clear water/greater visibility (caused by the removal of planktonic life) and the growth of fungi on the bottom of the lake. It is during the rainy season and also the winter thawing (which takes place in the spring) that the acid deposition influx to the water/land area is at its greatest. Plant life around the lakes is also affected because all the nutrients, metals, and minerals in the soil are removed (leached out) thus starving the plant life of needed nutrition and food. Hundreds of lakes have "died" in the northeastern United States and Canada due to acid rain. Many experts believe acid rain is a major cause of forest degradation. Other effects of acid rain in urban areas include accelerated wearing away of building surfaces.

c. How can we reduce acid precipitation? (Pollution controls on power plants, energy conservation, etc.)

d. Can acid rain affect a surface drinking water supply? There is considerable debate about this, but acid rainfall is more likely to remove toxic chemicals and heavy metals from land surfaces in a watershed and wash the chemicals and metals into a

reservoir. Also, pipes made of lead and other heavy metals in a water supply system can leach into the water. Acid rainfall on a reservoir can cause direct acidification.

Followup: See Air Pollution unit for further discussion of acid rain, pp. 108-111.

WATER: The Projects

- A. Organizing a Letter-Writing Campaign to Protect a Drinking Water Supply
- B. Organizing a Survey to Assess Conservation Efforts by Citizens

Discussion:

The organization of a letter-writing campaign is covered in other units. See Unit IV, Air - Project A; Unit VI, Noise-Project A; Unit VII, Nuclear Issues - Project A; and the Legislative Action section in Part II. Similarly, organizing a survey has been dealt with in Unit I, Solid Waste - Project C; Unit V, Open Space Beautification - Project B; Unit VIII, Transportation - Project A.

After involving the students/group in the issue lessons, the class could proceed to write letters and motivate others to write to key elected and appointed officials to protect a drinking water supply. Similarly a survey could be developed to assess the degree of water conservation being practiced by citizens.

For example, in 1986 and 1987 students from 6 high schools and one college participating in CENYC's Training Student Organizers (TSO) Program wrote (and motivated others to write) letters to elected and appointed officials on two issues affecting the long-term viability of New York City's upstate watershed system.

By way of introduction, eight to ten million residents of NYC and parts of Westchester County (approximately half of New York State's population) receive drinking water from reservoirs located in three watersheds in upstate NY (and Pennsylvania). However, NYC owns only a small portion of the land around the reservoirs and does not operate most of the sewage treatment plants that ring the watershed areas. A complex set of federal and state laws, state regulations, and agreements between the City and various towns and villages regulates the protection in the watersheds.

In one campaign, letters went to the Commissioner of the New York State Department of Health requesting that all sewage treatment plants whose effluent goes into streams and rivers that

are tributary to New York City's drinking water reservoirs maintain the highest standards including chlorination disinfection. A proposal made by the Town of Delhi to eliminate the chlorination disinfection requirement and reduce the extent of secondary treatment at the plant had been supported by the State Department of Environmental Conservation (DEC). Removal of these requirements might have led to more bacteria in the drinking water and development of diseases like cholera or diphtheria in the NYC population. It was feared that other localities whose plant effluents flowed into the NYC water supply would follow the example of Delhi and standards would be reduced at the 82 treatment plants along the City's watershed. Student letters to the State Health Commissioner with copies sent by participating teachers to state senators and assemblymen representing the areas around each school, and, in some cases, where students live, played a significant role in eventually convincing DEC to rescind support for a weakening of wastewater treatment standards.

Student letters to the NYS DEC commissioner and to state senators and assemblymen were a major factor in motivating DEC to agree to re-classify many wetlands tributary to NYC's drinking water reservoirs.

Such letter-writing (and/or petitioning) efforts can be applied to almost any water supply, whether surface reservoirs or groundwater, in any geographic region. In many sections of the U.S. or, for that matter, other countries as well, letter-writing campaigns by students and others could help to protect groundwater supplies from landfills, development, toxic waste dumps, etc.

Similarly, such a campaign can be utilized to convince elected or appointed public officials to limit development on wetlands that protect open commercial and recreational waters and other ecologically sensitive areas like lands over shallow aquifers. Construction and proper maintenance and operation of wastewater treatment plants are, of course, significant issues for open waters as well.

In the TSO Program, students have also done surveys of water use. One survey developed by students assessed the extent of use and misuse of fire hydrants during NYC's 1985 drought (see Auxiliary Materials section). Students from three sites participating in TSO analyzed 500 fire hydrants all over the Bronx and found 35% were either damaged or misused, causing water loss and inadequate fire safety. A report was submitted to the NYC Department of Environmental Protection (DEP) and led to the repair of many hydrants.

A survey of citizen conservation habits during the 1985 drought was conducted by students from three high schools. Over

400 homeowners and tenants from all over NYC were interviewed and it was found that while citizens were conserving in their public behavior (e.g., watering lawns, washing cars) due to fear of fines, they were not conserving as efficiently as they had in the 1981 drought with respect to private water use, that is, use within their homes. The results were given to NYC DEP who used the survey as evidence of the need for more long-term water conservation education. Obviously, surveys such as these can be done in any locality.

Followup:

* As stated in the Introduction to this unit, water pollution plays a major role in the grim public health situation in many developing countries. Certainly the projects mentioned in the preceding section can help in the third world, both in terms of developing awareness and organizing skills, and with respect to protection of drinking water supplies and cleanups of local open water which may be used for a variety of purposes. But in many developing countries, modern sewage treatment does not exist and human waste material with its many harmful bacteria and viral agents usually is directly dumped or in some way or another mixed in with water supplies intended for consumption or recreational use, or both. Therefore, obtaining access to a safe drinking water supply is a matter of life and death. The NY Times article on handpumps and the diagram from the UN Development Programme (in the Auxiliary Materials section of this unit) demonstrate one type of relatively simple project involving community participation which can improve drinking water supplies in developing countries.

* There are an increasing number of household products that are hazardous. While household hazardous wastes represent a solid waste problem in the immediate sense, the burial of most of these substances in landfills that are close to underground water supplies makes the household hazardous substances issue ultimately a water pollution problem. Of course, as more and more household waste is incinerated, then the by-products of burning household hazardous substances will be spewed into the air. The safe separation of household hazardous substances from the waste stream and their safe disposal should thus be a priority for municipalities across the country.

During the Fall 1989 school term, as this curriculum writing is being completed, CENYC's Training Student Organizers (TSO) program is beginning to work on this issue intensively. Students from several high schools have surveyed supermarkets for hazardous and non-hazardous products and a citywide report will be completed and made public. Previous to this, TSO worked with Lafayette High School students on a Household Hazardous Wastes Collection Day and with Martin Luther King Jr. High School students on a survey of hazardous substances in selected households.

WATER UNIT -- The Projects

AUXILIARY MATERIALS

1. Hydrologic Cycle diagram
2. Articles and diagrams on sewage treatment
3. Report on misused and abused fire hydrants
4. Hand pump article and diagram

HYDROLOGIC CYCLE

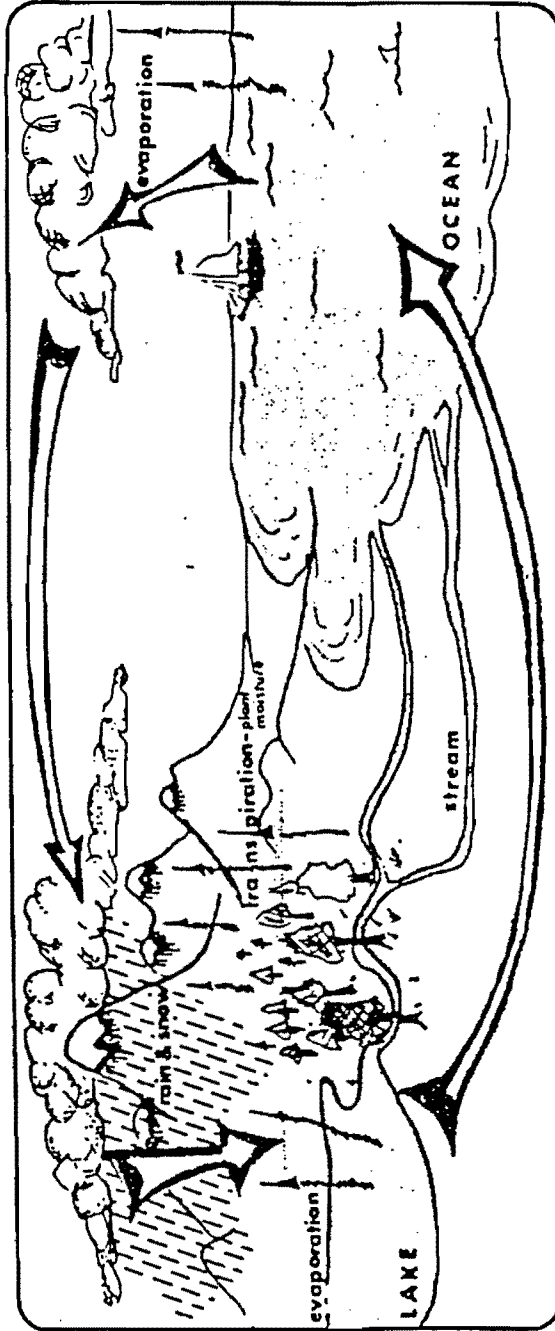

Source: Unknown

WASTEWATER COLLECTION AND TREATMENT

Treatment of wastewater is a relatively modern practice. While sewers to remove foul-smelling water were common in ancient Rome, it was not until the 19th century that large cities began to understand that they had to reduce the amount of pollutants in the used water they were discharging to the environment.

Despite large supplies of fresh water and the natural ability of water to cleanse itself over time, populations had become so concentrated by 1850 that outbreaks of life-threatening diseases were traced to bacteria in the polluted water.

Since that time, the practice of wastewater collection and treatment has been developed and perfected, using some of the most technically sound biological, physical, chemical, and mechanical techniques available. As a result, public health and water quality are protected better today than ever before.

The modern sewer system is an engineering marvel. Homes, businesses, industries, and institutions throughout the modern world are connected to a network of below-ground pipes which transport wastewater to treatment plants before it is released to the environment. Wastewater is the flow of used water from a community. As the name implies, it is mostly water, a very small portion is waste material.

At a typical wastewater plant, several million gallons of wastewater flow through each day — 50 to 100 gallons for every person using the system. The amount of wastewater handled by the treatment plant varies with the time of day and with the season of the year. In some areas, particularly communities without separate sewer systems for wastewater and runoff from rainfall, flow during particularly heavy rains or snowmelts can be much higher than normal.

What happens in a wastewater treatment plant is essentially the same as what occurs naturally in a lake or stream. The function of a wastewater treatment plant is to speed up the process by which water cleanses (purifies) itself.

A treatment plant uses a series of treatment stages to clean up the water so that it may be safely released into a lake, river or stream. Treatment usually consists of two major steps, primary and secondary, along with a process to dispose of solids (sludge) removed during the two steps.

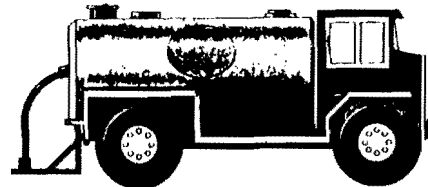

PRIMARY TREATMENT

In primary treatment, sand, grit and the larger solids in the wastewater are separated from the liquid. Screens, settling tanks, and skimming devices are most commonly used for the separation. Primary treatment removes 45 to 50 percent of the pollutants.

SECONDARY TREATMENT

After primary treatment, wastewater still contains solid materials either floating on the surface, dissolved in the water, or both. Under natural conditions, these substances would provide food for such organisms as fungi, algae, and bacteria that live in a stream or lake.

Most public wastewater treatment plants now provide a second stage of treatment known as secondary treatment to remove more of the pollutants — up to 85 or 90 percent altogether.

Secondary treatment is largely a biological process. Air is supplied to stimulate the growth of bacteria and other organisms to consume most of the waste materials. The wastewater is then separated from the organisms and solids, disinfected to kill any remaining harmful bacteria, and released to a nearby lake, river, or stream.

THE STUFF THAT'S LEFT BEHIND

You may have figured out by now that while treatment of wastewater solves one problem — clearing the water that is released from the treatment plant to the stream — it can generate others.

For example, the material that is removed from wastewater doesn't just disappear. It is called sludge. Sludge requires proper treatment and disposal, and can often be reused.

Sludge handling methods are designed to destroy harmful organisms and remove water. The end product of the sludge handling process is a relatively dry material known as "cake." It can be applied to agricultural land as a soil conditioner, placed in landfills, or cleanly burned.

At some plants, sludge serves as a fuel to produce energy.

Treatment of Sewage Is Seen as Insufficient To Protect Water Life

Improvements are urged as the amount of waste grows.

By ROCHIE LEE STANFIELD

WATER pollution control experts predict that more sophisticated and expensive treatment of municipal sewage soon will be necessary in some areas to save the fish and shellfish in rivers, bays and coastal waters.

Since 1972 Federal, state and local governments have spent \$70 billion to upgrade most of the nation's 3,700 largest sewage plants. Some bodies of water have been cleaned up, but because the total amount of sewage effluent has doubled in the last decade the overall amount of pollution remains about what it was in 1972.

In fact each day sewage plants across the country discharge billion gallons of treated effluent that still contains nutrients, particularly phosphorus and nitrogen, that reduce the oxygen in the water.

In sufficient quantity, these pollutants, along with nutrients from farm runoff, contribute to algal blooms that deprive other plants and animals in the water of oxygen.

Most of the sewage treatment plants "in the near future will have to do better at removing phosphorus and nitrogen, especially along the coastal estuaries of the East Coast," said Dr. Clifford W. Randall, chairman of the Environmental Engineering and Science Program at Virginia Polytechnic Institute and State University at Blacksburg.

Sewage treatment plants are divided into three categories, depending on the amount of pollution they remove. Primary treatment removes about 30 percent of the pollution, primarily large pieces of waste. Secondary treatment removes about 85 percent and tertiary removes 95 percent.

Across the country, 3,100 sewage treatment plants already perform some advanced or tertiary treatment to lower the nutrient concentrations in their 10 billion gallons of daily discharge. Virginia and Maryland, for example, have adopted regulations that will require advanced treatment at most plants dumping waste into tributaries of Chesapeake Bay.

Tertiary treatment systems usually are very expensive both to build and to operate. When the Virginia State Water Control Board was con-

templating its Chesapeake Bay regulation earlier this year, "this treatment possibility was the economic nightmare no one wanted to even think about," recalled David S. Bailey, Virginia director of the Environmental Defense Fund. Tertiary treatment requires more tanks, more aeration, more chemicals and more workers.

The cost of installing advanced treatment is difficult to generalize because the conditions and the technology differ from plant to plant. Operators of the mammoth Blue Plains Treatment Plant in Washington, D.C., estimate that the installation of advanced treatment facilities in 1981 cost \$500 million, half what it would cost to replace the entire plant.

An Environmental Protection Agency official estimated that tertiary treatment would add 47 percent to the \$7.5 million annual cost of operating a medium sized plant in Virginia.

But some experts, including some E.P.A. officials, favor alternative pollution strategies, especially those to control what experts call nonpoint pollution, such as runoff from farms.

"We're not confident that putting in very expensive, technically complex high treatment-level facilities always proves worth it," said Robert J. Blauco, director of the E.P.A. Municipal Facilities Division. "In the Chesapeake Bay, 60 percent of the nutrient problem comes from nonpoint sources. I don't think it makes a lot of sense in make communities spend a lot of money on these plants if you're not dealing with 60 percent of the problem."

He and others acknowledge, however, that in some cases advanced treatment will have to be used in combination with nonpoint control programs.

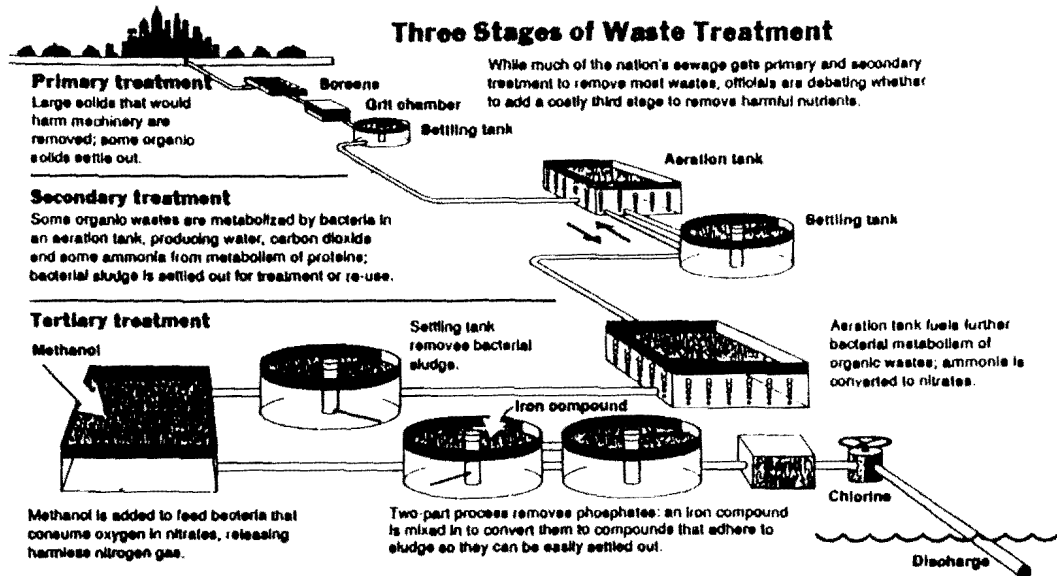

The New York Times. Source: Clifford W. Randall, Virginia Polytechnic Institute and State University.

Some experts on water pollution, say the E.P.A. is reluctant to predict that wholesale installation of advanced treatment plants will be required soon because it has been so costly and politically difficult to bring the majority of plants in the country up to secondary treatment.

"They've had their hands full just getting into secondary," said Howard Levenson, a senior analyst for the Congressional Office of Technology Assessment who has directed sewage treatment studies. "Everybody knows that nonpoint sources are a problem. In certain situations, nutrients from sewage may be the problem, but nobody wants to talk about it."

Nearly 90 percent of sewage treatment plants in New York State meet

the minimum Federal standards, in Connecticut the figure is 82 percent. But only 61 percent of New Jersey's plants comply.

In addition to the \$70 billion spent to upgrade plants to secondary treatment, the E.P.A. estimates that \$76 billion will have to be spent to meet all the sewage treatment needs documented in 1986. However, only \$4.3 billion of that amount is projected for advanced treatment. Many of the experts contend that is a gross underestimate, although they do not offer what they would consider a more realistic figure.

Dr. Randall argues that the most promising way to bring down the cost of tertiary treatment is through new technology.

In essence, primary treatment

screens out the largest solids from incoming sewage. Secondary treatment uses huge circulating tanks to mix the sewage with air and bacteria, which consume the organic waste. The mixture is piped to sedimentation tanks where the sewage-filled bacteria settle to the bottom as sludge. Some of the sludge is piped back into the aeration tank to provide the bacteria to work on new sewage. The rest is treated, disposed of or recycled as compost.

For all its expense, tertiary treatment is simply a continuation of the aeration and settling process in additional tanks. In one step, chemicals are injected to change the compounds of phosphorus so that they will adhere to the sludge. In another process, methanol is added so a different kind

of bacteria can turn nitrogen compounds into harmless nitrogen gas. That process relies on bacteria that live without oxygen and therefore does not require aeration. One of the expensive side effects of advanced treatment is increased sludge from these bacteria, with higher disposal costs.

Dr. Randall has experimented with a cheaper one-tank biological nutrient removal system that produces less sludge and eliminates the addition of chemicals. It also requires less energy because less oxygen is required for aeration. He installed a temporary system on a seven-million-gallon-a-day treatment plant for \$155,000. Construction costs to make that system permanent would cost about \$1 million, he said, while conventional tertiary treatment equipment would have cost \$5 million to \$6 million.

The biological system is still considered experimental because it has been used primarily on small plants in warmer climates. Dr. Randall said he had been asked to install the system at a 200-million-gallon-a-day plant in Baltimore.

Mr. Blauco of the E.P.A. said he is enthusiastic about the potential of the biological process but cautious because it remains in the experimental stage. Containing the cost of advanced treatment is critical, he said. "You really have to think about what the market can bear before you install facilities that are very sophisticated but the communities can't afford to operate," he said.

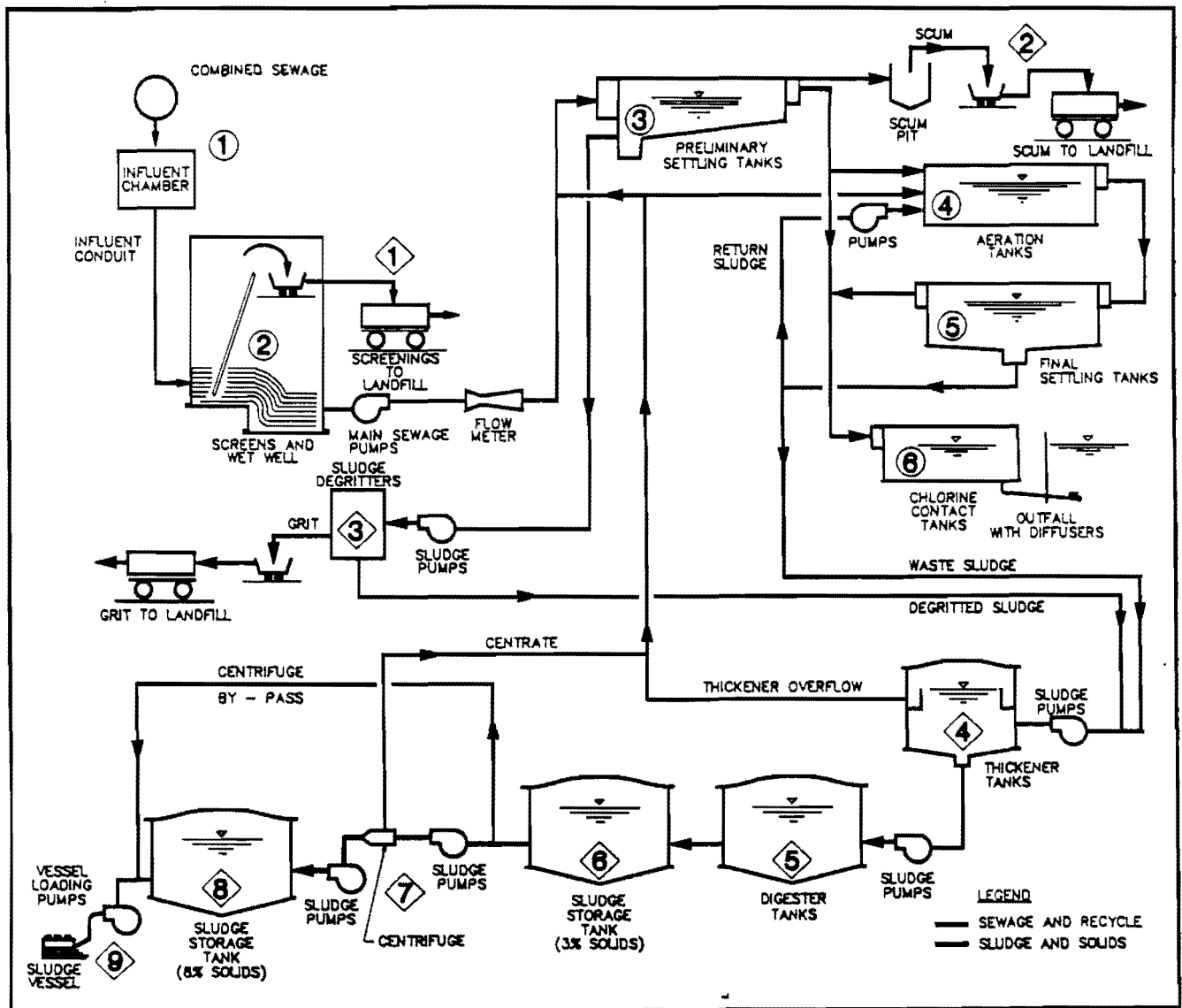

Advanced Preliminary Treatment (May 1987 to May 1989)

- ① Influent
- ② Screening
- ③ Preliminary Settling
- ⑥ Disinfection

Secondary Treatment (After May 1989)

- ④ Step Aeration
- ⑤ Final Settling
- ⑥ Disinfection

Solids Handling and Disposal

- ① Screenings Removal and Disposal
- ② Scum Removal and Disposal
- ③ Grit Removal and Disposal
- ④ Sludge Thickening
- ⑤ Mesophilic/Thermophilic Digestion
- ⑥ Storage - 3% Solids
- ⑦ Centrifuge
- ⑧ Storage - 8% Solids
- ⑨ Ultimate Disposal

Source: NYC Department of Environmental Protection



COUNCIL ON THE ENVIRONMENT OF NEW YORK CITY

Marian S. Heiskell
Chairman

David Lenefsky
Vice Chairman

Richard Abrons
Secretary

Shirley Dralfus
Treasurer

Lys McLaughlin
Executive Director

MEMBERS

Bruce Babcock
Saybrook Capital Corporation

Martin S. Begun
NYU Medical Center

Kenneth Benton
Metropolitan Life Insurance Company

Ivan F. Boesky

Dr. Arline Bronzalt
Lehman College, CUNY

William J. Dean
Attorney

Christopher Elliman
Eimrock Partners

Lois Geraci Ernst
Advertising To Women, Inc

Jonathan D. Farkas
Live Oak Realty Corporation

Dr. Thomas H. Fay
Columbia Presbyterian
Medical Center

Charles A. Fisher
Fisher & Levy

David Gurin
NYC Dept of Transportation

George Lamb
American Conservation Association

Robert M. Litke
NYC Dept of General Services

Marjorie W. Longley
The New York Times Company

Joseph T. McGough, Jr.
NYC Dept of Environmental Protection

Woodie Pagan, Esq.
Cotino & Pagan, P.C.

Thomas Pappas
United Federation of Teachers

William Pierce
Chemical Bank

Ellen O'Flaherty Pratt
Protectors of Pine Oak Woods

Ross Sandier
Natural Resources Defense Council

Norma Stanton
Hispanic Women's Center

Norman Steisel
NYC Dept of Sanitation

Henry J. Stern
NYC Dept of Parks and Recreation

Ruth Ann Stewart
NY Public Library

Roger L. Strong

David L. Vaughn
Pfizer Inc

Harriet L. Warm

HONORARY MEMBERS

Carter Burgess

John O. Riedl
Queensborough Community College

REPORT ON MISUSED AND ABUSED FIRE HYDRANTS IN THE BRONX AND UPPER MANHATTAN

Prepared by: DeWitt Clinton High School, General Science Students,
from Macy Medical Science Honors Program
Lehman College, Geology and Geography Students
John F. Kennedy High School, General Science Students

In cooperation with the Council on the Environment of New York City's
Training Student Organizers Program

February 1986

51 CHAMBERS STREET, ROOM 228 NEW YORK CITY, NEW YORK 10007 (212) 566-0990

REPORT ON MISUSED AND ABUSED FIRE HYDRANTS
IN THE BRONX AND UPPER MANHATTAN

Prepared by: DeWitt Clinton High School, General Science Students,
from Macy Medical Science Honors Program
Lehman College, Geology and Geography Students
John F. Kennedy High School, General Science Students

In cooperation with the Council on the Environment of New York City's
Training Student Organizers Program

DeWitt Clinton High School

David Dixler, Teacher

Michelle Allen
Roy Allen
Ricky Baez
John Balkaran
Danny Balkcom
Velinda Ballantine
Carlos Banitez
Albrecht Benschop
Malcolm Bush
Vanessa Bynes
Veronica Collins
Phuoc Cung
Sonia DeJesus
Ramon Diaz
Chevonne Dixon
Santos Dumena
Pedro Fonseca
Sandra Hatch
Lernice Henry
Haroon Ijaz
Bhonani Jaimagal
Nicky James
Colleen Jones
Ka Lee
Anand Liliah
Raquel Lopez
Marin Mar
Jenneth Martin
Angel Medina
Tabatha Mendoza
Kendrace Miller
Lizette Pagan
Gerri Parvilus
Cynthia Perez
Iris Pico
Kisha Pressley

Elizabeth Ramirez
Rosa Ramirez
Rafael Reyes
Marisol Rivera
Adelyn Robinson
Cary Rodriguez
Stacie Seabron
Keacha Simpson
Sonia Washington
Maggie Zegarra

Lehman College

John Daniels, Instructor

Carl Becker
Rosario Hernandez

John F. Kennedy High School

Ralph Guttman, Teacher

Melanie Bergmann
Denise Figueroa
Daniel Guzman
Shazam Immamicee
Janeth Mendez
Sonia Montalvo
Maria Peterson
Annette Rodriguez
Lissette Rosario
Jose Siandre
Danny Vasquez
Lamar Wilson

INTRODUCTION

Concern about both the City's drought crisis and the need to educate youth concerning water conservation spurred CENYC's Environmental Education staff to contact the NYC Department of Environmental Protection (DEP) in the summer 1985 to elicit ideas for action projects that could be organized by students in the Council's Training Student Organizers (TSO) program (See Appendix 1). DEP's Office of Regulatory Review sent our request to Department staff. A response came quickly from John Rivera, Director, Office of Community Technical Assistance. Mr. Rivera felt that students could perform a valuable function that would assist DEP staff by surveying fire hydrants to see whether they were being abused or misused during the drought period. A vandalized hydrant might be leaking valuable gallons of water (a full flowing hydrant emits one million gallons of water during a 24 hour period!) or it might become damaged to the extent that it could not be used by the fire department to put out fires possibly leading to loss of life and/or property. Using a hydrant for car washing or drinking is illegal and during the drought such activity wasted extremely valuable quantities of water.

We thought that this project idea would be particularly interesting to General Science students from DeWitt Clinton's Macy Medical Science Honors Program, a special program to introduce selected students to medical and health career opportunities, and to TSO students at Lehman college and John F. Kennedy High School as well. When introduced to the hydrant project idea, teachers and students seemed motivated by the possibility of doing something about the drought, by being involved in public service. The following report documents the study.

TABLE OF CONTENTS

Introduction

I. Method

II. Results

Table A - Basic Statistics for Hydrant Survey
Table B - Problem Hydrants By Community Board
Table C - Problem Hydrants by Neighborhood
Table D - Types of Problem Hydrants By Area
Graphs

III. Analysis, Conclusions, and Recommendations

Appendix

Hydrant Survey Form
Maps (A and B) of Where Students Live and
Observed Hydrants

METHOD

Fifty-eight high school and college students surveyed 489 fire hydrants using observation. The students recorded their observations on a survey sheet (See Appendix 2). Most of the students observed 5 hydrants each.* The hydrants were generally spread throughout the Bronx and Upper Manhattan where the students live (See Appendix 3). These observations were made between October 24th and November 7th, 1985.

* A few students observed less than five hydrants while two students from Lehman college observed 213 hydrants as part of a special intense survey in one neighborhood - Community Board 7 and 8 in the Northwest Bronx.

RESULTS*

Table A - Basic Statistics for Hydrant Survey (Total # observed = 489)

TYPE OF PROBLEM	# OF PROBLEM HYDRANTS	% OF TOTAL PROBLEM HYDRANTS	% OF TOTAL HYDRANTS OBSERVED
Caps Missing	118	71.1%	24.1%
Water Use	22	13.3%	4.5%
Locks Off	9	5.4%	1.9%
Caved In, Tilted	9	5.4%	1.9%
Leaks	6	3.6%	1.2%
Tipped Over	2	1.2%	.4%
TOTAL	166	100.0%	34.0%

* In tabulating the results multiple problems for certain hydrants were not tabulated - only the most serious or obvious problems. For example, the caps figure (118) represents hydrants that had no other more serious problem, e.g., leakage, physical damage, or observed water use. Some of the hydrants in the other categories also were missing their caps when first observed.

Table B - Problem Hydrants by Community Board*

COMMUNITY BOARD	TOTAL # OBSERVED	# OF PROBLEM HYDRANTS AND % OF THESE OBSERVED IN EACH BOARD
#1 - Bronx	25 (5 students)	3 (12%)
#2 - Bronx	30 (6 students)	7 (23.3%)
#3 - Bronx	20 (4 students)	5 (25%)
#4 - Bronx	55 (11 students)	17 (30.9%)
#5 - Bronx	25 (5 students)	5 (20%)
#6 - Bronx	8 (1 student)	6 (75%)
#7 - Bronx	208 (9 students)	79 (38%)
#8 - Bronx	45 (2 students)	21 (70%)
#9 - Bronx	5 (1 student)	3 (60%)
#10- Bronx	8 (2 students)	0 (0%)
#11- Bronx	5 (1 student)	4 (80%)
#9 - Manhattan	5 (1 student)	3 (60%)
#12- Manhattan	50 (10 students)	13 (28%)
TOTAL	489	166

* Please note that these are approximate figures since in some cases it was very difficult to determine which board a problem hydrant was located in. Several hydrants were very close to the border of the boards.

Table C - Number of Problem Hydrants by Neighborhood or Area as Compared to Number of Hydrants Observed in Each Area*

NEIGHBORHOOD OR AREA	TOTAL NUMBER OBSERVED	# OF PROBLEMS	% OF PROBLEMS IN EACH AREA
South Bronx (C.B. #1,2,3,6)	83	21	25.2%
Southwest Bronx (C.B. # 4)	55	18	32.7%
Northwest Bronx (C.B. # 5, 7,8)	278	104	37.4%
East Bronx (C.B. #9, 10, 11)	18	7	38.8%
Northwest Manhatttan (C.B. #9 and 12)	55	16	29.0%
TOTAL	489	166	

* The grouping of the boards into general neighborhood areas is of course done in an arbitrary way here. For example, we are looking at the Boards east of Webster Avenue and below the Bronx Zoo as being the South Bronx. Some would include all or part of the Southwest area (C.B.#4) especially the area between Webster and the Grand Concourse in the "South Bronx". Others would not include Community Board 6 in a traditional South Bronx layout. Definitions of the Northwest Bronx also differ. We simply divided and grouped in a way that we felt made the most sense out of the data.

Table D - Some Statistics for Types of Problem Hydrants by Area

Similar types of problems	SOUTH BRONX (CB 1,2,3,6)		SW BRONX (CB 4)		NW BRONX (CB 5,7,8)		EAST BRONX (CB 9,10,11)		NW MANHATTAN (CB 9 and 12)	
	#	% of total observed (83)	#	% of total observed (55)	#	% of total observed (278)	#	% of total observed (18)	#	% of total observed (55)
Water use and leaks	8	9.6	6	10.9	2	0.7	1	5.5		12.7
Caved in, tilted or tipped over	3	3.6	0	0	2	0.7	0	0	2	3.6
Missing Caps or locks	10	12.0	12	21.8	101	36.4	6	33.3	7	12.7
TOTALS	21	25.2	18	32.7	105	37.8	7	38.8	16	29.0

GRAPHS

TOTAL HYDRANTS

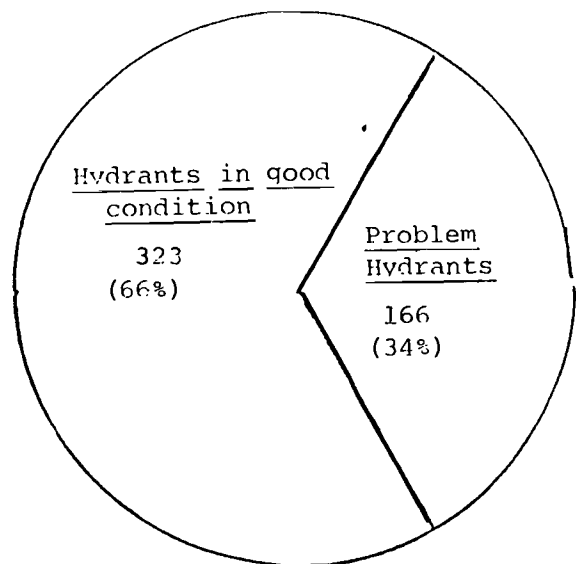

PROBLEM HYDRANTS

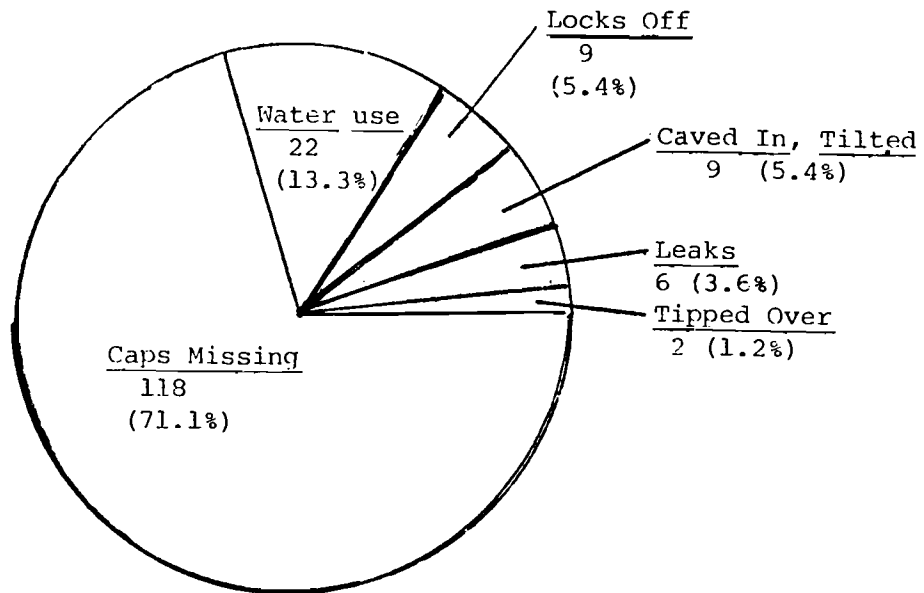

III. CONCLUSIONS AND RECOMMENDATIONS

A. We feel that some physical damage to or misuse of more than 1/3 of the total fire hydrants observed represents a serious problem in the sections of the Bronx and Upper Manhattan where the hydrants were observed. It seems that at least some citizens do not respect the hydrants as physical property of the city.

B. While our survey was not a completely random one, we also feel that the approximately 500 hydrants observed (a little over 3% of the hydrants in the Bronx were looked at) from many neighborhoods in several major regions of the Bronx and Upper Manhattan indicate that the results may reflect similar abuse and misuse patterns throughout the Bronx (and Upper Manhattan) and possibly the entire city.

C. The biggest problem was missing caps or hydroshields (118 or 71.1% of problems). The missing caps don't necessarily indicate a water conservation problem. While having to remove the caps would make using the hydrants a little more difficult for someone who wanted to wash a car for example, any person who had the equipment to turn the top of the hydrant to release water should also probably be able to pry the caps loose to allow the water to flow out. However, since the hydrants are usually left with the caps off water can continue to leak. We think it is fair to assume that hydrants without caps which have not been otherwise vandalized will be more likely to be used illegally and eventually to leak, thus wasting water.

D. Missing caps can be an even more serious problem for fire safety. Hydrants with missing caps are more likely to be vandalized especially by having rocks or other items thrown into the openings. This causes the hydrant to be useless making it impossible to use when the fire department is trying to put out a fire. Loss of life and damage to property could be the result.

E. After the missing caps, the next most serious problem was the 6 leaking hydrants and the 22 hydrants that were being used during our observation. While none of the 6 leaking hydrants had water gushing out in full force and it cannot be determined for how long water was flowing out of the 22 used hydrants, one hydrant emitting water at full force for a 24 hour period will waste one million gallons of water. A significant amount of water was probably wasted from leaking hydrants and from used hydrants during the drought period.

F. When all the numbers are considered, it seems that the main conclusions with respect to area is that the South Bronx area as we defined it (see Table C) had somewhat fewer problem hydrants while the percentage of problem hydrants was consistently high up the entire western corridor of the Bronx - the area from Yankee Stadium to University Avenue and the Northwest area above that.

G. It is our major recommendation that the Department of Environmental Protection repair all the hydrants both to save water and increase safety in the event of fires in the areas mentioned. While it would seem to be common sense that repairs should begin in the areas most affected - Northwest and Southwest Bronx - the fire safety factor makes us feel that the Department should assess whether

fires occur more frequently in any one area and begin repairing hydrants there. Of course, the fire department should be informed and involved.

H. We also feel that the Department of Environmental Protection should begin a program to educate all New Yorkers, especially the youth of the city about water conservation and the water supply system, educating students on the role of each of the systems' components including fire hydrants.

APPENDIX

HYDRANT/WATER CONSERVATION OBSERVATION SHEET

Both sides
of block

Instructions: Observe every hydrant within a two square block area of your house. That is walk two blocks in one direction from your house, then two blocks in the other directions (east, west, north, south) until you return to your house. For example:

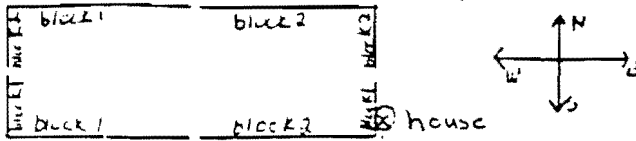

Observations/Data Collection

Hydrant # _____ Student's Name _____

Date _____ Student's Address _____

1. Location of hydrant*- _____

2. Is there any water leaking from the hydrant? ___ yes ___ no. If yes, describe. _____

3. Is the hydrant broken, that is, is it tipped over and laying on the ground? ___ yes ___ no. If yes, describe _____

4. Is the cover or cap that goes on the hydrant openings off? ___ yes ___ no. If yes, describe _____

5. Has the bar or lock that goes on some hydrants been taken off? ___ yes ___ no. If yes, describe _____

6. Is anything else that should be on the hydrant not there? Has the hydrant been "caved in" or "depressed"? ___ yes ___ no. If yes, describe _____

7. Did you see anyone use water from the hydrant? ___ yes ___ no. For what purpose? _____
How long did the water leak? _____

Secondary Data for Signs and Violations Schedule on that Street

List the name and address of any commercial stores on this street:

Name of store	Address	Gave Water Conservation Sign		Gave Drought Penalty Schedule	
		yes	no	yes	no
_____	_____	___	___	___	___
_____	_____	___	___	___	___
_____	_____	___	___	___	___
_____	_____	___	___	___	___

List additional stores on back of sheet.

* Location - Record street or avenue hydrant is on and avenue or street it is between. For example, hydrant is on 163rd between Third Avenue and Eagle Avenue or on Prospect Avenue between 165th St. and 166th St. If the hydrant is in front of a building, record the address of the building, too. If there is more than one hydrant on a street, try to tell what corner it is closest to, for example, closest to the corner of 166th St and Prospect Avenue.

Appendix 2 - Map of Where Students Live and Observed Hydrants by Community Board

- Where each student observer lives

Bronx

COMMUNITY DISTRICTS

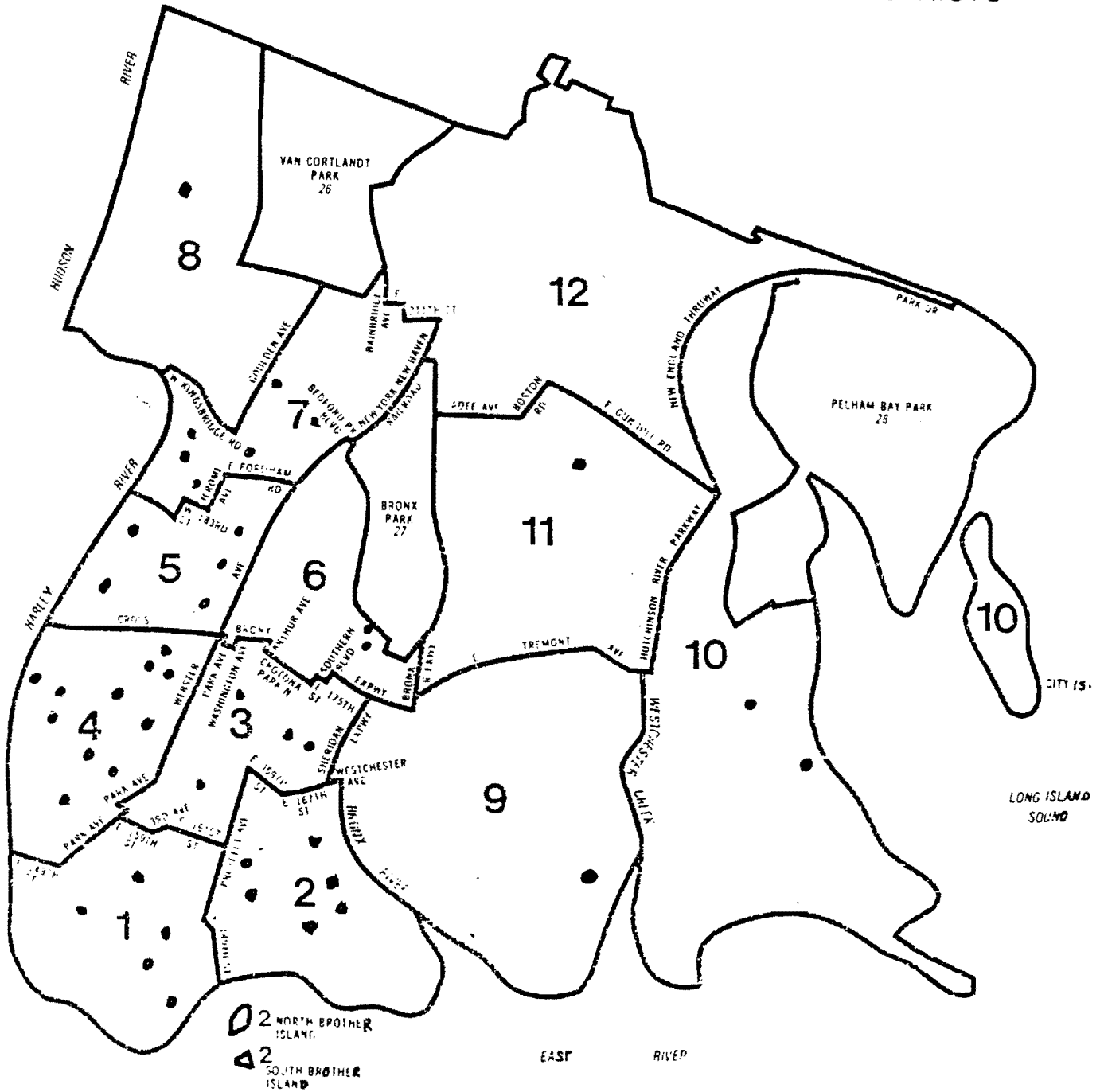

● Where each student observer lives

Manhattan

COMMUNITY DISTRICTS

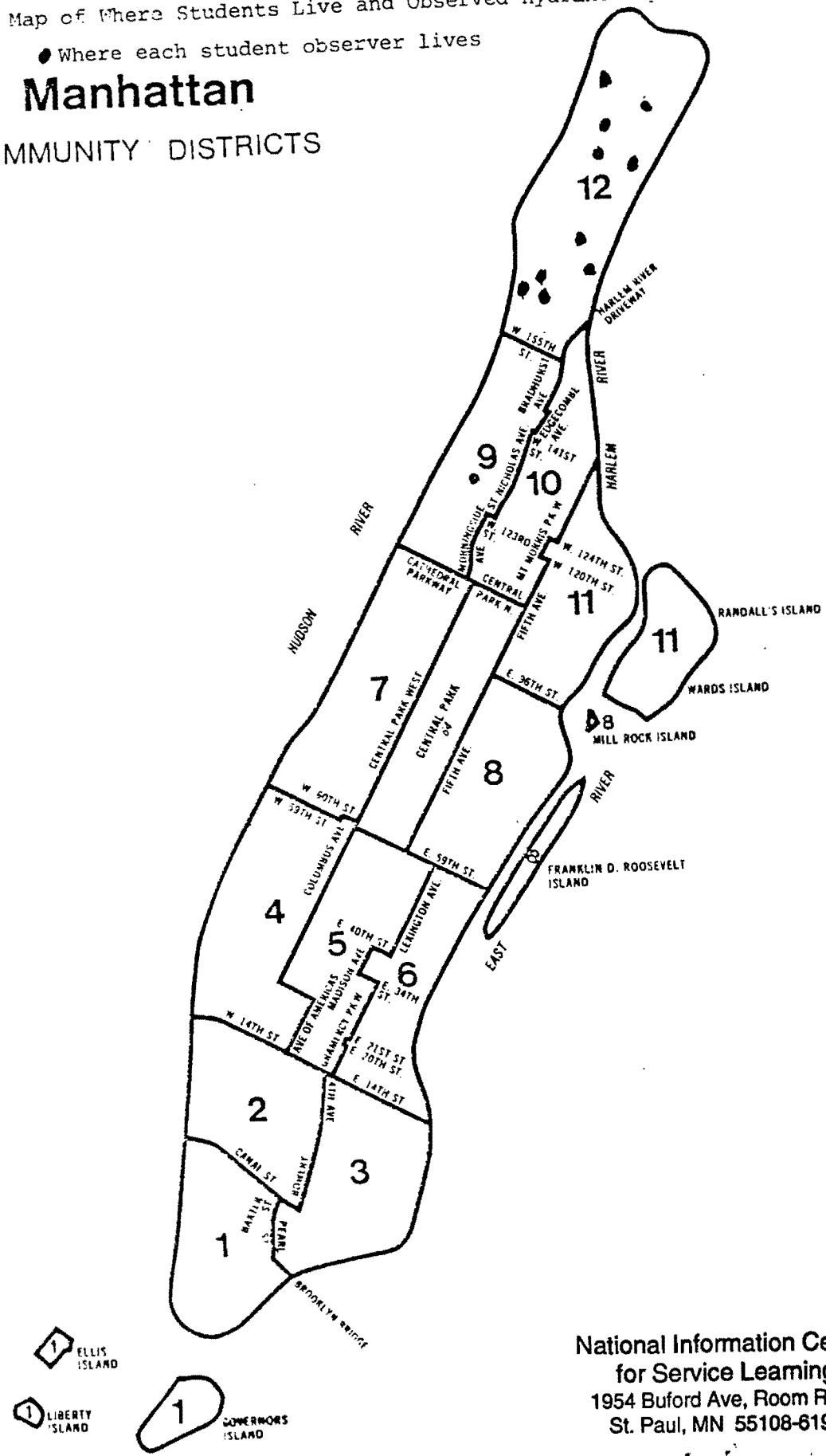

National Information Center
 for Service Learning
 1954 Buford Ave, Room R290
 St. Paul, MN 55108-6197

Kwale Journal

Road to Good Water Strewn With Failed Projects

By SHEILA RULE

Special to The New York Times

KWALE, Kenya — At daylight's first blush, the women of this tropical district for generations have begun the long walk to faraway rivers and streams to collect water for their families.

They have returned home hours later with water, unclean and unsafe, that has been largely responsible for the district's having one of the highest death rates among children in this east African country. Their plight has been similar to those of nearly two billion other people in developing countries who, the United Nations says, still haul water from distant and contaminated sources, a practice resulting in millions of deaths a year.

But the situation in Kwale began to improve a few years ago with the aid of a global program promoting the use of a device dating to ancient Rome — the hand pump. Experts on the subject say that the pump provides one of the simplest and least expensive means of supplying safe water to populations in rural communities and those on the fringes of urban areas in the developing world.

"There was so much diarrhea, bilharzia and cholera," said one woman, sitting under the umbrella of towering trees. "Many people were dying. People didn't have time to do any other work because they were always looking for doctors to treat them. Things are better now."

A Dramatic Decrease

Thousands of people involved in the program in Kwale now walk only as far as their village hand pump, installed in wells placed where ground water of good quality is available, to fetch clean water. Hospital officials here say that, although the prevalence of some water-related diseases remains high, the new system has contributed to a dramatic decrease in reported cases of diarrheal diseases and the virtual eradication of cholera.

The hand-pump project, sponsored by the World Bank and the United Nations Development Program, tested 70 different types of the machine in 20 countries in Africa, Asia and Latin America in an effort to find the most appropriate designs. The program is part of a worldwide campaign by the United Nations, through its International Drinking Water Supply and Sanitation Decade, to provide reasonable access to safe drinking water and sanitation to the underdeveloped world by 1990, after a 10-year drive.

The decade began in a landscape strewn with failed water projects — even now, in the view of some water experts, at least 40 percent of the facilities are not working at any one time — that used inappropriate technology and lacked community participation. The current program, which receives financial support from several donor nations, has

sought to resolve these and other problems. It has recommended most highly pump designs such as the Afridev in Kenya and the Tara in Bangladesh, which use parts made of an affordable and durable plastic known as polyvinyl chloride. The devices are designed to be produced by local manufacturers in poor countries and easily installed and repaired by ordinary villagers living in the harsh conditions of rural communities.

Financial Constraints

A new report on hand pumps by the project's sponsors suggests the magnitude of the task of providing safe water. While the campaign has produced improvements in rural water supplies in all of the world's regions, the five-year study showed, it faces severe financial and technical constraints, high population growth rates and other problems.

The report provided these and other findings on the first three years of the decade:

¶Asia had the greatest success in building new rural water systems, with about 70 million people annually obtaining improved water in rural areas. At the same time, the rural population grew by 15 million a year. If the trend continued and the commitment to construct and maintain water systems remained strong, the

region would reach virtually full coverage by the end of the century, 10 years later than the original goal.

¶Rural water services in Latin America and the Caribbean were provided at a rate of three million people a year, twice the population growth rate. If the same pace was maintained, all needs would not be met until well into the next century.

¶In Africa, the provision of improved rural water for 10 million people each year has just kept pace with the galloping population growth rate of about 3 percent a year and, if this continues, no more than half of the rural population will have access to an adequate supply of clean water by the end of the century.

Proud of Their Progress

Despite the less-than-favorable outlook for their continent, the people of this district in the fertile southeastern corner of Kenya, wedged between the coastal city of Mombasa and the Tanzanian border, speak proudly of their progress.

Like participants in the hand-pump program in other parts of the globe, people here have used the project as a springboard to community development and the involvement of women in ways that go beyond their traditional roles. With support from the Swedish International Development Agency, local government officials and the Kenya Water for Health Or-

ganization, a nongovernmental group, women have established committees and opened bank accounts in preparation for taking over full responsibility for maintaining, repairing and replacing hand pumps.

The people of Kwale are learning, too, in lessons in sanitation and health education, that the availability of clean water alone is not enough to lessen the rate of illness. A World Bank report suggests that about 80 percent of the enteric diseases experienced by people in the developing world are associated with not only unsafe water but also inadequate sanitation and poor personal hygiene. Hospital workers here say that mounting awareness among villagers has led to an increase in both the use of sanitary pit latrines and efforts by women to insure that the clean water they take from the hand pumps remains clean in their homes.

"When we started, there was a lot of resistance from people," said Lojomon Biwott, manager of the water project in Kwale.

"People were used to old hand pumps breaking down. They were untrained and couldn't get spare parts and so they returned to the old ways of doing things. But the health environment has been improved and women have been trained as caretakers and the response from the community to hand pumps now is very strong."



The rotary driven Monolift pump has proven popular among users—especially children.

From: Water and Sanitation for Health: Toward the Year 2000,
United Nations Development Programme.

REFERENCES

Basic Environmental Technology: Water Supply, Waste Disposal, and Pollution Control, Jerry Nathanson, John Wiley & Sons, 1986.

Community Piped Water Supply Systems in Developing Countries, Daniel A. Okun and Walter Ernst, World Bank Technical Paper Number 60, World Bank, Washington DC, 1987.

National Water Quality Inventory, 1986 Report to Congress, United States Environmental Protection Agency, Nov., 1987.

Woods and Water, developed by the Environmental Action Coalition for the New York State Department of Environmental Conservation, New York City, 1987.

UNIT IV: AIR

Introduction

Imagine that you are preparing home-made spaghetti sauce. You gather together whole tomatoes, tomato paste, minced onions and garlic, mushrooms, oregano, and other ingredients. Place them into a large pot on a stove and let them cook for a good while. The end product is a wonderful, zesty, aromatic sauce in which all of the individual ingredients have blended together to produce a taste more flavorful than the sum of its individual parts. The air that we breathe is very similar to your spaghetti sauce (though not always as tasty). The composition of the atmosphere, and its healthiness, is the result of the synergistic and composite effects of a multitude of gases, vapors, and particulates.

Air is mostly a mixture of a number of gases. Its composition has changed over time (particularly since the advent and evolution of oxygen-producing, carbon dioxide-consuming green plants). In its "pure" state, air consists of 78% nitrogen, 21% oxygen, 0.03% carbon dioxide, and less than 1% of argon and other trace gases. However, air is rarely pure. Nitrogen oxides from lightning sulfur from volcanic eruptions and natural decay, hydrocarbons (such as terpenes) from trees are created by natural processes and added to the atmosphere for millennia. However, pollutants from human activities, from the cooking fires of early Homo sapiens to the Industrial Revolution to the heavy industries of today, have far exceeded those from natural sources in terms of both quantity and potential toxicity. Air pollutants from incinerators and automobiles, from smelters and power plants, from copy machines and refrigerators, particulates, aerosols, vapors and gases from thousands of sources, all intermingling, interacting, and synergizing are evidence and by-products of modern society's consumptive way of life.

Air pollution control is controversial, expensive and complex. Many factors must be considered in any attempt to control sources of air pollution. What are the economic costs of installing (or not installing) scrubbers on power plant smoke stacks? What are the human health effects of carbon monoxide and nitrogen dioxides emitted by automobiles? Should higher bridge or roadway or tunnel tolls be charged in highly congested urban areas? Air pollution control has been accused by industries and utilities of restricting economic growth. Are increased health costs and risks, defaced public structures and monuments, defoliated forests, and sterilized lakes an equitable price to pay for a productive economy? These are questions that the American public must answer in the 1990s and beyond.

Air: The Issue

Lesson #1

Aim: To learn about the sources and types of air pollution.

Motivation: Do you think that most air pollution comes from natural or human-made sources?

Discussion:

a. What are some of the major human-made sources of air pollution? (motor vehicles, e.g. cars, buses, trucks, boats, industries and fossil fuel power plants.)

TABLE 1: ESTIMATED POLLUTION EMISSIONS BY SOURCE
(1984, millions of metric tons)

<u>SOURCE</u>	<u>TOTAL SUSPENDED PARTICLES</u>	<u>SULFUR OXIDES</u>	<u>NITROGEN OXIDES</u>	<u>CARBON MONOXIDE</u>
Transportation (cars, trucks)	1.3	0.9	8.7	48.5
Combustion (power, heat)	2.0	17.3	10.1	8.3
Industrial processes	2.5	3.1	0.6	4.9
Solid Waste (incinerators)	0.3	--	0.1	1.9
Miscellaneous	0.9	--	0.2	6.3
TOTAL	7.0	21.3	19.7	69.9

(Source: National Air Quality and Emissions Trends Report--1984, Environmental Protection Agency, April 1986)

b. What are some naturally caused sources of pollutants?

- ▶ Dust storms
- ▶ Tree pollen
- ▶ Fires

► Volcanic action

c. What are the major air pollutants in the United States?

TABLE 2: NATIONAL EMISSION ESTIMATES
(1975-1984, millions of metric tons)

	1975	1976	1977	1978	1979	1980	1981	1982	1983	1984
Suspended particles	10.4	9.7	9.1	9.2	9.0	8.5	7.9	7.0	6.7	7.0
Carbon monoxide	81.2	85.9	91.9	81.5	78.4	76.2	73.5	7.2	70.4	69.9
Sulfur Oxides	25.6	26.2	26.3	24.5	24.5	23.2	22.3	21.3	20.6	21.4
Nitrogen Oxides	19.2	20.3	21.0	21.0	21.1	20.4	20.5	19.7	19.1	19.7

(Source: National Air Quality and Emissions Trends Report--1984, Environmental Protection Agency, April, 1986)

The four pollutant categories listed above contain gases that concentrate in the atmosphere at a certain height above street level. Other pollutants, such as lead, concentrate at lower levels that are below the level of most monitoring stations and therefore are not included in this listing.

Since the advent of the widespread use of unleaded fuel in the mid-1970s, though, the average lead levels in the blood of Americans have decreased by as much as 50%.

Carbon monoxide is an odorless, colorless, poisonous gas produced by incomplete combustion. It is prevalent in areas of high population and traffic densities. Sulfur oxides are by-products of fossil fuel incineration, while nitrogen oxides (poisonous and highly reactive) are produced by high temperature combustion. Suspended particles arise from natural and human-made sources (e.g. asbestos pipe-wrapping, pesticides, etc.) and from combustion of different materials from many sources.

Photo-chemical oxidants, such as ozone, are created by the synergistic reactions of sunlight with nitrogen dioxide and certain hydrocarbons. Hundreds of other reactions can then take place as long as there is ozone or nitrogen dioxide and sunlight. These photo-chemical oxidants, visible as a haze resulting from the sun's effects on them, are frequently referred to as smog.

d. What is the most prevalent pollutant in the United States? Carbon monoxide, in both tonnage and percentage,

accounts for more than half of the nation's air pollution. It arises predominantly from internal combustion engines and is concentrated in congested urban centers.

Followup:

* Discuss various strategies to reduce the number of automobile commuters into the heart of a major urban center (e.g., by raising bridge or tunnel or roadway tolls, higher parking fees, car-pooling, improving regional mass transit, car-free zones, etc.).

* Have students do research on specific air pollutants and their effects (e.g., effect of chlorofluorocarbons on the ozone layer).

Lesson #2

Aim: To learn about the health effects of air pollution.

Motivation: Speaker from local health department to talk on air pollution sources and health effects.

Discussion: Use the results of the students' research on various air pollutants to lead into a more detailed discussion on the health effects of specific air pollutants. For example:

a. Carbon monoxide -- reduces oxygen-carrying capacity of hemoglobin in blood, thereby affecting the cardiovascular, respiratory, and central nervous systems.

b. Sulfur dioxide -- causes shortness of breath, aggravates respiratory ailments, and irritates the eyes.

c. Nitrogen oxides -- irritates and causes structural and chemical changes in the lungs.

d. Ozone -- irritates breathing, causes choking, and impairs lung functions.

TABLE 3: TYPICAL POLLUTANTS
Some Sources and Health Effects

<u>Pollutant</u>	<u>Source</u>	<u>Health Effect</u>
Arsenic	Coal and oil furnaces, glass manufacturing	Long term exposure may cause lung and skin cancer
Benzene	Refinery emissions, gasoline motor vehicle exhaust	Long term exposure may cause leukemia

<u>Pollutant</u>	<u>Source</u>	<u>Health Effect</u>
Cadmium	Smelter emissions, burning wastes, emissions from coal and oil furnaces	Long term exposure damages kidneys and lungs, weakens bones
Chlorine	Emissions from chemical industries	Forms hydrogen chloride, irritates mucous membranes
Carbon monoxide	Emissions from motor vehicles, coal and oil furnaces, smelters, steel plants	Starves body of oxygen, damages heart
Fluoride ion	Emissions from smelters, steel plants	high concentrations mottle children's teeth
Hydrocarbons	Unburned gasoline vapors	Combine with nitrogen oxides in sunlight to form smog
Formaldehyde	Emissions from motor vehicles, chemical plants, used in some glues	Irritates eyes and nose, may be a factor in causing cancer
Hydrogen chloride	Emissions from incinerators	Irritates eyes and lungs
Hydrogen fluoride	Emissions from fertilizer plants, smelters	Irritates skin, eyes and mucous membranes
Mercury	Emissions from coal and oil furnaces, smelters	Causes tremors, behavior problems
Nitrous acid	Nitrogen dioxide and water vapor combine in the atmosphere	Causes respiratory ailments
Hydrogen sulfide	Emissions from refineries, sewage treatment, pulp mills	Causes nausea, irritates eyes

Sulfuric acid	Sulfur dioxide and hydroxyl ions combining in sunlight	Causes respiratory ailments
Manganese	Emissions from steel plants, power plants	Long term exposure may lead to Parkinson's Disease
Nickel	Emissions from smelters, coal and oil furnaces	High exposure may cause lung cancer
Nitrogen dioxide	Emissions from motor vehicles, coal and oil furnaces	Causes bronchitis, lowers resistance to influenza
Ozone	Hydrocarbons and nitrogen oxides combining in sunlight	Irritates eyes, aggravates asthma
Hydroxyl radical	Hydrocarbons and nitrogen oxides combining in sunlight, reacts with other gases to form acid droplets	Depends upon synergistic linking with other ions
Peroxyacetyl nitrate	Nitrogen oxides and hydrocarbons combining in sunlight	Irritates eyes, aggravates asthma
Lead	Emissions from motor vehicles, smelters	Causes brain damage, high blood pressure, impairs growth
Silicon tetrafluoride	Emissions from chemical plants	Irritates lungs
Sulfur dioxide	Emissions from coal and oil furnaces, smelters	Obstructs breathing, irritates eyes

(Source: "Air: An Atmosphere of Uncertainty," Noel Grove, National Geographic, April 1987)

Lesson #3

Aim: To explore the issue of air pollution controls and the economy.

Motivation: Speaker from local power company to give a presentation on emission control devices and how they impact on the economy of the community.

Discussion:

a. What are the financial costs to a community for emission control devices for power plants and industries?

b. What would be the effects of the elimination of pollution control devices upon the natural and built environments? Many critics believe that expensive air pollution control technology restricts economic growth and is a financial burden to consumers. Do the costs outweigh the benefits? These are important policy decisions to be made by governmental, community, and business leaders.

c. What will be the long term social, economic, and environmental effects of the "greenhouse effect" caused by fossil fuel use? The burning of coal, oil and natural gas to produce electricity and space heating leads to the emission of large amounts of carbon dioxide and oxides of nitrogen, which accumulate in the atmosphere and trap the sun's heat, causing the earth's temperature to rise. The emission of chlorofluorocarbons (CFCs) from the production and disposal of refrigerators and solvents, and naturally occurring methane (CH_4) also contribute significantly to the "greenhouse effect."

Air: The Issue -- Focus on Acid Rain⁹

Lesson #1

Aim: What is acid rain?

Motivation: How does our lifestyle affect our level of energy consumption?

Discussion:

- a. What are the major energy sources?
- b. What are fossil fuels and how are they formed?
- c. What are the consequences of the burning of fossil fuels? Sulfur dioxide and nitrogen oxides are emitted by the

⁹ Also see discussion of acid rain in unit "Water," pp. 73-74.

burning of coal and gasoline respectively. These gases then react with water and sunlight to produce acid precipitation (rain, snow, hail).

Followup:

* Have students research and report on different air pollution control technologies.

* Organize a debate among students concerning the social, economic, and environmental costs of installing air pollution control systems in power plants and industries.

Lesson #2

Aim: How can we determine the acidity of precipitation?

Motivation: Test the pH, using pH test paper or a pH test kit from the school's science lab, of a variety of solutions: e.g. vinegar, ammonia, lemon juice, milk of magnesia, tap water, distilled water, soda, etc.

Discussion:

a. What is pH? pH is a measure of the alkalinity or acidity of water and other liquids. It is measured according to a logarithmic base-10 progression from 0 to 14 with 7 being neutral, and acidity increasing as scale gets closer to zero. For example, pH 4 is 10 times more acidic than pH 5, and 100 times more acidic than pH 6.

b. Have students collect wide-mouthed jars with tops from home. Rinse the jars with distilled water and close them until they are to be used. When it rains, have the students go to pre-determined spots and place jars in open areas where the rain can fall directly into them. After collecting at least one centimeter of water, students should cap jars tightly and return them to class to be tested. Students should record the date, time and location of collection.

c. Test samples by placing the pH test paper into a test tube with tweezers. Add rainwater, stopper tube and shake vigorously for approximately one minute. Compare the color of the pH paper with a pH color key card. Record the data, and map the locations of the various collecting sites. How do the pH ratings compare with the theoretical rainwater pH average of 5.7? Is there any apparent geographical pattern to the pH measurements of the various samples? If so, what could be the cause of such a pattern?

Followup: Students could monitor and test rainwater samples for a number of months. Is the pH pattern consistent? Are there fluctuations in the measurements? Why?

Lesson #3

Aim: Where does acid precipitation fall?

Motivation: Where does acid precipitation occur in this country and the world?

Discussion:

a. Review the weather cycle, and review the production of atmospheric pollutants from fossil fuel power plants.

b. Arrange for a speaker from the local weather service to visit the class to discuss atmospheric circulation patterns and possibly bring along a series of sequential weather maps for exhibition and study.

Followup:

* Develop a pen-pal relationship with a class of high school students in northern New England or eastern Canada that is monitoring the pH of its local precipitation. Exchange data and information concerning the nature of the local industries.

* Have students research the meteorological and geologic factors that make an area sensitive to acid rain. Why is there so much acid rain in the northeastern United States and southeastern Canada, and why is acid precipitation having such an effect in those regions?

Lesson #4

Aim: What are the effects of acid precipitation on terrestrial and aquatic life systems?

Motivation? Is acid precipitation toxic to aquatic and terrestrial life forms?

Discussion:

a. Take a trip to a local freshwater pond or a natural freshwater wetlands. Develop an inventory of representative species of flora and fauna by using a variety of field guides. (Or, if this is not possible, arrange for a speaker from the state conservation department to hold a slide presentation/talk on aquatic/terrestrial systems.)

b. Have students do research on the life cycles of individual animal species (e.g., beaver, trout, loon, etc.). What

are their food sources? How often do they breed? When do they breed? How many offspring? Present this information in table form in a bulletin board display.

c. What are the proper living conditions for these animals and some of the plants that were identified in the first part of this lesson? What are their tolerance levels for pH, temperature, precipitation, etc? (Sources for information may be the state conservation department and the local agricultural extension service.) Present this also in table form as a bulletin board display.

d. If feasible, take periodic readings of local ponds. Record this data and determine if there are any seasonal trends in pH levels.

Followup:

* What would happen to the pH of a local pond if there was a sudden spring thaw that melted accumulated snowfall that was considerably acidic? Would the pH rise or lower? What effect would this have on indigenous or migrating wildlife? What effect does acid rain have on a pond? on a forest?

* What effect would acidic precipitation have on marble or limestone structures? Take a field trip to an old cemetery to examine weathered grave markers. If there is a power plant in your neighborhood or city, ask representatives to discuss any contributions their plant has on increasing acid rain.

Air Pollution: The Projects

A. Organizing an acid rain letter-writing campaign

Lesson #1

Aim: To write legislative action letters to United States senators concerning acid rain.

Motivation: How can we motivate our elected officials to enact legislation to decrease acid precipitation?

Discussion:

a. One of the most effective means of expressing a viewpoint to an elected official is to write a letter. It is a widely accepted premise that an elected official assumes that a single letter represents the interests of at least ten (and sometimes many more) of her or his constituents.

b. Have the students write letters to their state's United States senators expressing their views of the acid precipitation problem.

c. Have students inform others (in the school, community, etc.) about acid rain precipitation and encourage them to write letters too.

d. Send copies of these letters to the United States representative(s) representing the students' neighborhoods.

e. See section on Letter-Writing in Part II, pp. 230-238 and letter-writing campaign in "Noise" and "Nuclear" units.

Followup:

Organize a petition campaign directed to the U.S. senators, in the school or community, that requests action against acid precipitation. Send copies to the local U.S. representatives.

B. Organizing a Letter-Writing and Public Awareness Campaign Concerning Chlorofluorocarbons

Lesson #1

Aim: What is ozone?

Motivation: What is the structure of the Earth's atmosphere?

Discussion:

a. How is the Earth's atmosphere organized? The troposphere is the layer of the atmosphere that contains the air we breathe. It extends 6 to 10 miles above the ground. The lower stratosphere extends 10 to 20 miles above the surface, while the upper stratosphere is 20 to 30 miles above ground.

b. What is ozone? Ozone, at the surface levels, is a pollutant produced by the interaction of sunlight, nitrogen oxides, and hydrocarbons. It is an eye irritant and can aggravate asthma. However, at higher levels in the upper atmosphere constituted as the ozone layer (12 to 30 miles above the ground), it intercepts damaging ultraviolet radiation from the sun.

c. What would life on Earth be like without an ozone shield to screen out damaging ultraviolet radiation? How would increased radiation that would result from a defective ozone shield affect plants, humans, other animals, etc.?

Followup:

Have students prepare oral presentations on the sources and health effects of ozone and other low-level atmospheric pollutants.

Lesson #2

Aim: What are CFCs (chlorofluorocarbons)?

Motivation: What are the industrial uses of CFCs?

Discussion:

a. What are CFCs? CFCs (chlorofluorocarbons) are widely used industrial compounds of chlorine, fluorine, and carbon.

b. What properties do they have that make them so attractive for industrial use? Developed in 1930, CFCs are non-toxic, odorless, non-corrosive, and non-flammable.

c. What are their industrial uses? Different compounds of CFCs serve many purposes and are prevalent throughout industrialized societies. They include: packaging (food and non-food items), solvents, cleaners, hospital sterilants, refrigerators (home and retail food), air conditioners (home and automobile), and aerosols.

Followup:

* Have students conduct research on uses of CFCs and which industries produce them. Determine if any of these industries are within the community.

* Determine if substitutes for CFCs are commercially available.

* Conduct a survey on which nations produce CFCs and the volume of their production.

Lesson #3

Aim: How do CFCs affect the ozone layer?

Motivation: Are CFCs harmless?

Discussion:

a. How are CFCs released into the atmosphere? They are released to the atmosphere when they, or a product containing them, are manufactured, used or disposed of.

b. What effect do they have upon the atmosphere? CFCs, when emitted, rise through the troposphere into the lower stratosphere. At an altitude of approximately 15 miles, ultraviolet light breaks a chlorine molecule from a CFC molecule. The now free chlorine atom interacts with an ozone molecule and breaks off an oxygen atom, resulting in a chlorine monoxide molecule and an oxygen molecule. A free oxygen atom then combines with the chlorine molecule, freeing the chlorine atom and forming an oxygen molecule. The chlorine is now free to attack another ozone molecule and repeat the process. A single chlorine atom can, over time, destroy 10,000 ozone molecules.

c. What are the sources of these CFC molecules? Some products emit CFCs during or immediately after production (several days or weeks) and some products "bank" them and release them when the product is serviced or destroyed in years or decades to come. For example, CFCs from solvents are released promptly, while CFCs from automobile air conditioners are "banked."

d. How long do CFC molecules remain active in ozone destruction? CFCs have a considerable atmospheric life span. Some CFC compounds are active for 5 to 10 years, while others continue to destroy ozone for over 350 years.

Followup:

* Have students research the effects on the community or nation's economy of a halt in CFC production. Do alternatives to CFCs exist for air conditioners and refrigerators?

* Can CFCs be recycled? Have students look into the technical feasibility of recycling refrigerants.

Lesson #4

Aim: To write letters to local municipal officials.

Motivation: What can we do on a local level concerning CFC pollution/ozone depletion?

Discussion:

a. See this unit, Project A, Lesson #1, on writing letters.

b. Have the students write letters to local municipal officials requesting the establishment of centralized recycling centers for the reclamation of refrigerants. The substances could then be sold as recycled refrigerants.

c. The students could also write letters to state legislative officials to require the recovery of CFCs when refrigerators and automobiles are junked. The letters could request the establishment of appropriate laws to that effect.

d. A public awareness campaign, presentations to community organizations, etc., could be launched encouraging businesses and consumers to remove and recycle the CFC loaded refrigerant in refrigerators and air conditioners before disposing of them.

REFERENCES

Air Pollution and Human Health, by Lester Lave, Johns Hopkins University Press, 1977.

Air Pollutants and Their Effect on the Terrestrial Ecosystem, ed. by Allan H. Legge, Sagar V. Krupa, New York: Wiley, 1986.

Effects of Pollutants at the Ecosystem Level, ed. by Patrick J. Sheehan et al., Chichester, New York: Published on behalf of the Scientific Committee on Problems of the Environment (SCOPE) of the International Council of Scientific Unions (ICSU), J. Wiley, 1984.

Fundamentals of Air Pollution, by Arthur C. Stern et al., Orlando: Academic Press, 1984.

No World Without End: The New Threats to Our Biosphere, Katherine and Peter Montague, Putnam, New York, 1976.

UNIT V: OPEN SPACE BEAUTIFICATION AND PRESERVATION

Introduction

Open spaces such as parks, playgrounds, lots, gardens, and landscaped areas are an essential part of the total environment. Trees, plants, vines, grass, flowers, and vegetable gardens are aesthetically pleasing, provide oxygen, and give comfort and joy to all. Natural elements interact with the built or man-made structures like buildings and streets to produce a total effect on the inhabitants of a particular area.

Yet open spaces, whether in the city, suburbs, rural or wilderness areas are under severe development pressures. Whether it's a 100' by 50' lot utilized for a high rise condominium on Broadway and 57th Street in New York City, or thousands of acres in a national or state recreation area being considered for commercial development, government and industry often look at open spaces only as resources to be utilized in meeting the perceived needs of society.

Open space projects can beautify the environment; they can also educate people about the importance of preserving open space and of including open space in all man-made environments, whether the open space be an existing natural area or newly landscaped.

Open Space Beautification and Preservation: The Issue

Lesson #1

Aim: To discuss the beautification and preservation of open spaces.

a. What do we mean by open space?

▶ Open spaces within a built environment include: parks, pocket parks, vacant lots, vegetable gardens, landscaped areas, playgrounds, plazas, streets, squares, front yards.

▶ In natural areas, open spaces include: forests, shoreline areas, wetlands, etc.

b. How will preserving and enhancing open spaces benefit residents?

▶ Trees, plants, shrubs, grass provide us with beauty, shade, oxygen, and cool breezes during hot weather; cut down on noise pollution by acting as buffers; and also provide a natural habitat for birds, insects, animals, etc. By taking in carbon dioxide during photosynthesis, trees and other plants help curb the Greenhouse Effect.

▶ Wetlands and coastal area vegetation serve as habitats for

wildlife, protect surrounding waters from pollution, and control floods.

c. What are some possible open space beautification/preservation projects in the built environment or natural areas?

► Turning vacant lots into pocket parks, planting flowers or vegetables on vacant lots or on rooftops, park re-design, street tree planting and care, plant identification, locating and treating diseased street trees, letters or petitions to public officials to keep certain forests, wilderness areas or wetlands free from development.

Followup:

Have the students take a neighborhood walk with pencil and note pads, perhaps maps and cameras as well, to identify and record the natural open spaces, wetlands, forest areas in and around your town, village or city, and the parks, lawns, plazas, squares, gardens, wall murals, playgrounds, signage in the built environment of the buildings, streets, and transportation systems of the city or town.

Lesson #2

Aim: To learn about street and natural area beautification and preservation.

Motivation: On the chalkboard or on a stencil, draw a simple diagram of the area observed on the field trip recommended in the followup to Lesson #1. Have the students fill in the space with their observations, i.e., place major open spaces in their appropriate places on the diagram.

► What would make the streets, roadways, or natural areas better, e.g., more trees, benches, window boxes, fewer or better-designed parking spaces, wider sidewalks, roadside flower gardens, etc.?

Discussion:

a. Why is it important to beautify neighborhoods, towns, and cities?

► People tend to respond to their environment and to other people in a healthier and more effective way when they are in an aesthetically pleasing environment.

b. By beautification, do we mean simply appearance?

► Neighborhood or village beautification involves planning, design, community effort and cooperation. The design of a space must meet the aesthetic, functional, and psychological needs of the people who inhabit and travel through the space. For example, painting an appropriate mural on an outdoor wall will personalize the wall as well as beautify it. A small park can be designed so that senior citizens can comfortably and easily talk to each other, so that handicapped persons can move through the space, and so that pedestrian traffic may find the park an inviting resting place. Park benches can be repaired and painted, if necessary, and other ornaments added for visual and functional effect.

c. Natural areas within or adjacent to the neighborhood or village can be improved through cleanups and plantings, and if appropriate, preservation efforts.

Followup:

Using the organizing steps detailed in the Solid Waste unit, students participating in TSO have organized a number of beach and coastal cleanups. Such projects stress the importance of keeping the marine environment free of plastic floatables, medical wastes, sewage, etc. for commercial, recreational and marine animal preservation purposes while focusing on solid waste issues such as litter reduction and garbage management. Such projects are fundamentally efforts to preserve and enhance natural areas and are open space preservation efforts.

For each of the past four years, 175 students in TSO from several South Brooklyn, South Queens, and Staten Island high schools in New York City have participated in a cleanup of four beaches in the Gateway National Recreational Area. Usually one or two classes from one of the schools serves as the organizing class and contacts the other schools, does publicity with press releases, etc. Buses to bring students to and from the cleanup sites are arranged for either by the Gateway Environmental Studies Center or by each individual school in cooperation with the New York City Board of Education. These cleanups have helped clean the beach and coastal areas and have inspired many student participants to be active around these open space, solid waste, and water pollution concerns.

A number of other such beach/coastal area cleanups have been organized by students in TSO on Long Island Sound and the Bronx River and more are planned.

One natural area project which combined direct service (e.g., cleanup type approach) and political action (e.g., letter-writing campaign) was organized by Beach Channel High School students in Rockaway, Queens, to protect Dubos Point, a wetland in Jamaica Bay. Cleanups, salt marsh grass plantings, birdbox

installation, letters and petitions were organized and the students played a major role in convincing the New York City Parks Department to sign an agreement with the NYC Audubon Society allowing Audubon to manage the wetland for ten years. Beach Channel students will play a role in that management.

Open Space Beautification/Preservation -- The Projects

A. Organizing a Park Clean-up and/or General Park Improvements

Lesson #1

Aim: Why are parks important?

Motivation: How would you feel if there weren't any parks in your city, town or village?

Discussion:

- a. What activities do you enjoy doing in the park?
- b. What parts of the park do you enjoy most?
- c. What would life be like without the trees, animals, birds, playgrounds, flowers, etc. that are in the park?
- d. What happens to a park in which people litter and which is not cared for on a regular basis?
- e. What condition is your local park in? What are the problem areas? The positive aspects?
- f. What can this class do to help?

Followup:

* A field investigation to assess overall park conditions, the need for improvement, specific areas for improvement, etc., can be undertaken. The observations of park conditions can be recorded in a log or on a map.

* Discuss with students why some people might litter or vandalize a park. Do some persons feel negative about the city they live in? Do these feelings justify negative behavior like damaging a park bench? Is littering related more to negative attitudes or carelessness?

Lesson #2

Aim: To begin planning the cleanup/beautification/preservation project.

Motivation: Should we organize a cleanup of our park or activities like bench paintings, plantings, etc.?

- a. Should we do all of these?

b. What would each type of project entail? (The choice of whether to focus on one or any of these activities should depend on resources available, student motivation, etc., but if students are capable we suggest using a multi-activity approach when involved in park revitalization. This should keep student interest high and give the project greater impact.)

Discussion:

Proceed in much the same manner as outlined in Unit B: Solid Waste, The Projects, Project A, Lesson #2, (p. 42). Here the issue is Open Space Beautification/Parks. The factors to be considered are much the same with, of course, the local parks department as a prime contact for this project. The local "Friends of the Park" group, if any, may also help. While the organization of a general clean-up or beautification day involving adults and youth in the neighborhood is a good way to start, a project in which the class does at least the initial work (e.g. cleanup) by itself is also feasible. Of course, the efforts to motivate others to participate could then be curtailed. With sufficient publicity, students would draw attention through their efforts to the need for park revitalization.

Followup:

Assign students to do a flyer and any other publicity method decided upon.

Lesson #3

Aim: To continue planning, organizing, and implementing the park project.

Continue in much the same way as in Unit B: Solid Waste, The Projects, Project A, Lessons 3-5 (pp. 43-45), depending upon what kind of outreach plan you decide on with the class. See also Part II of the curriculum for section on outreach plan. Analyze what followup activities may be necessary.

B. Organizing a Survey/Report on Park and/or Playground Conditions

Special Project Summary The lessons and steps for this project become obvious if you review Lesson #1 of Project A in this section and Project C, Organizing a Survey/Report on Neighborhood Commercial Street Sanitation in the project section of the Solid Waste unit (pp. 47-50).

After reviewing the overall significance of parks, it is important to determine whether a particular condition, e.g., playground safety in a specific park or park usage merits a survey. An inventory of park equipment, e.g., benches, lights or a survey of wildlife species is another possible focus. Then follow the steps in Project C of the Solid Waste section, pp. 47-50. See Auxiliary Materials after this unit for examples of park survey sheets used in CENYC's Training Student Organizers Program.

C. Coordinating a Graffiti Removal Campaign

Lesson #1

Aim: To discuss the rationale for a graffiti removal campaign.

Motivation: Do you think graffiti beautifies the environment or makes it ugly?

Discussion:

a. Discuss with students why the usual "scribble" type of graffiti is considered by most people to be a blight on the environment.

b. Discuss how graffiti can cause safety problems in addition to defacing the environment (subway car maps, windows, other directionals).

c. Distinguish, if you wish, between the "scribble" type of graffiti and legitimate art works that use graffiti and pop art style images.

d. Discuss the possibility of giving legitimate graffiti "pop art" artists an opportunity to display murals, with permission, on cleaned walls.

e. Discuss areas in the school or neighborhood that need graffiti removal.

f. Try to elicit from the students the understanding that graffiti removal can be part of an overall beautification campaign in the school and/or neighborhood.

Lesson #2

Aim: To plan the project.

Motivation: Where should we target our graffiti removal campaign?

Target, with the class, the best location for graffiti removal in terms of visibility, practicality, need, etc. Probably a site on the school campus would be best unless the class is capable of organizing away from the school grounds, i.e., in the surrounding neighborhood or their own neighborhoods. It is probably best to start with one significant space for organizational and symbolic reasons, although the effort can be quickly expanded to other spaces. The custodian and custodial workers should be contacted to gain their support. By graffiti removal, we mean covering the graffiti with a safe, non-toxic paint or other substance. The chemicals which totally remove graffiti from surfaces are too toxic for students to handle.

Discussion:

- a. Use the model employed in previous projects:

Issue: Open Space Beautification/Graffiti

Project

Strategy

Method/Tactics

Service/Direct Action

Paint over graffiti

Target population--
Students, community residents

- b. Discuss and identify target groups to be reached. Assign students to speak to them. See Outreach Plan in Part II, pp. 209 and following.

- c. Discuss arranging and giving presentations, preparation of flyers and posters.

- d. Discuss procurement of necessary materials, e.g., paints and brushes. Should this be done by fundraising for costs or through material donations from paint stores, merchants in the neighborhood, etc.?

- e. Discuss getting support and help for the project from the school administration including the custodian; if the project is to be done outside the school, getting support from those in charge may be more complex. The community board or town council

would need to be contacted and the owner of the space if it is privately owned.

Lesson #3

Aim: To prepare a fundraising letter.

Motivation: How will we obtain the materials we need to do graffiti cleanup?

Discussion:

a. Review Lesson #2 and discuss the need for a letter from the class to local banks and businesses to raise money for materials. Also, should a letter asking for money be sent to organizations within the school, like the alumni association and PTA, etc.?

b. An adaptation of the letter could be used for paint stores asking them to donate materials.

c. See Part II, pp. 201, 212-215 for help in preparing letter requests for money or materials.

d. Assign students to type the letters after they are reviewed by the class. The letter should go out at least 5-6 weeks before the event itself.

Lesson #4

Aim: To prepare a flyer, poster, and press release.

Motivation: How can we let people know about the event?

Discussion:

a. After reviewing the fundraising letter and taking steps to make sure it is sent to the appropriate places, spend the rest of the period developing a flyer which can also be used as the basis for a poster.

b. See Part II, pp. 198, 205-208.

c. Remember the flyer must answer the questions: where? when? who? So make sure this information is included. Make sure flyer distribution starts at least 2-3 weeks before the graffiti removal event.

d. Discuss who will prepare, print, and distribute the flyer. Develop a team to post the flyers and distribute them

widely. Specific distribution should come when person-to-group presentations are made.

e. Discuss how posters can be developed from the flyer. Who will draw the posters -- the art department or the class itself? Who will distribute them and where? Posters should mainly be put up in visible areas in the school and neighborhood. Can the flyer (enlarged or not) be used as a poster?

f. Which group will write the press release? Perhaps a separate lesson is necessary on this. Again, see Part II, p. 202. In addition to the school paper, what newspapers and TV/radio stations in the town and community groups should the releases be sent to? If participation from local residents is required, a press release asking for participants should be sent out well in advance of the day. Call local paper(s) to determine when such an announcement should be sent.

Lesson #5

Aim: Review outreach plan and prepare presentations.

Motivation/Discussion:

a. Look over the flyer, make any final changes, and give to appropriate student or student team to reproduce.

b. Then make reference to target groups mentioned in Lesson #2; specifically mention which groups in the school -- associations, clubs, teams, elected councils -- will be contacted directly, and when.

c. What about community organizations? Will they participate in this, even if the removal will occur only on school grounds? Should community groups be notified, if only to tell them about the event and make them more aware of the need for public participation in clean-up activities?

d. Send out press release to list developed previously.

e. Mention that a presentation is the best way to reach groups targeted for participation, followed by dissemination of the flyer.

f. Determine which students will contact particular groups who are to receive presentations. Presentation dates should be about ten days to two weeks from this session and at least ten days-two weeks before the event.

g. Start to practice presentation with the students. Refer to Part II, p. 220 for presentation format.

h. Role-play presentation(s) if possible.

Lesson #6

Aim: Continue to practice presentation(s), then plan for the event.

Motivation/Discussion:

- a. Continue practicing presentation(s).
- b. Review fine details of who will be giving presentation(s) to what groups and when?
- c. Role-play presentation(s) again; improve where necessary.
- d. Use last 15 minutes of period to begin reviewing details of the actual graffiti removal event:
 - ▶ Have all expected funds come in?
 - ▶ Is procurement of materials proceeding?
 - ▶ Has the time for the event and release of students (those in the class and in other classes) been arranged?
 - ▶ Has the school administration and/or community authorities given the students permission to work on the wall, or whatever space the graffiti will be removed from?

Lesson #7

Aim: To review graffiti issue again and its place in beautification as organizing goes on.

Motivation/Discussion:

- a. As presentations are being given, flyers disseminated and posted, posters put up, materials procured, etc., review again what was covered in Lesson #1, the problem of graffiti.
- b. Other methods of graffiti removal could be covered here.
- c. Discuss how graffiti removal relates to other beautification activities: anti-littering, cleanups, plantings, etc.

Lesson #8

Aim: Final review before action.

Motivation/Discussion:

a. Review plan for event. Plan to have student organizers supervise all participating students in actual removal/coverup.

b. Assign some students to make sure painting materials are gathered and disseminated at the event.

c. Make sure cleanup tasks are assigned to organizers.

d. Review all contact organizing--presentations, flyers--and make any final assignments necessary to ensure participation.

Followup:

Evaluation of event. Discuss with students in terms described in Part II, pp. 225-229.

Keep in mind that with graffiti removal, as with most open space projects, those who would deface a wall space will probably graffiti whatever wall has been cleaned. It is important to be vigilant and continue to remove whatever graffiti is placed on a wall until the urge for such vandalism is stymied. In other words, a "struggle" for this particular wall space will probably ensue after the initial removal, and the organizing group has to be set to deal with this. As with preserving a park space, a garden, a public square, etc., it is important for the school/community group to take "ownership" of the wall space and act so that it becomes identified as a public space not to be vandalized.

A long term solution with respect to wall spaces might be to invite community artists, including legitimate graffiti artists, to submit designs for murals which may be chosen by school and/or community organizations to beautify the wall. See mural project lessons immediately following this lesson.

D. Organizing a Mural/Public Art Project

Lesson #1

Aim: To discuss the importance of murals and other works of public art in overall open space beautification.

Motivation: Do you see any murals on your way to school? Do you like them? Do they make your world more beautiful?

Discussion:

a. Why do some murals make your neighborhood or school environment more beautiful?

b. Is it because they are attractive, or tell us something about a subject or our lives?

c. What other kinds of public art works do we often see (for example, sculpture)?

d. Should an artist paint a mural on a wall or other similar kind of space without permission of the owner or the community?

e. The interaction over this latter question could be quite complex. While, in general, public artists should and do obtain permission to use a wall for a mural, and most efforts to use a public space for personal artistic expression without the direct or indirect cooperation of the community do fall into the category of negative graffiti, certainly there are many instances in this country and others where meaningful public art work has been rendered without permission of "the authorities." The political and social context within which this occurs can be discussed with students. However, in most instances the proper permission should be obtained for use of a space, and certainly in doing the project recommended in this unit.

f. Would you like to paint a mural to beautify the school?

Followup:

Obviously, this project is more easily done with an art class/group, but many times there is sufficient artistic talent in a non-art class to at least develop an initial design for a mural. Certainly the expertise of the art department and/or community artists should be sought at all stages of the process.

Lesson #2

Aim: To discuss and explore location (and theme) for the mural. (This sample mural project is an in-school project. Public art projects organized in the community would follow similar steps but have to, of course, obtain permission from whatever private or public entities own the space to be beautified and have rights of review or approval over space use. Also, whatever wall space is utilized needs to be checked to be sure that the surface is suitable for a painting. Certain walls may not be usable, or may not support the painting.)

Motivation: What's a good place to put the mural and what theme should it have? Let's take a walk around our school and make some observations.

Discussion: (before, during, and after walk)

- a. What do you think is a good place for a mural?
- b. How many people will benefit visually in each possible location? What space needs to be beautified the most? How does that space relate to the surrounding environment?
- c. What possible themes would fit in each possible location?
- d. Which persons in the school should we contact concerning choice of a space? (Art chairperson, principal, assistant principal for administration, custodian, etc.)
- e. What's the best location for our mural?

Followup:

Should we include location along with the theme/design in a vote or contest for the final mural to be rendered?

Lesson #3

Aim: To discuss choice of theme and design for the mural project.

Motivation: What should be the theme for the mural? How should we choose the design?

Material for Discussion: (Could take several sessions, depending on process selected.)

The process of choosing a theme and design for the mural can range from simple to very complex. Ideally, a public art project should be participatory and should in some way involve the eventual "recipient" of the visual improvement in the process of theme/design choice. This can be done by conducting a contest for theme ideas with the choice among submissions made by a panel of teachers and students (or appropriate community representatives, if a community project). Designs representing the theme can then be developed by art students and/or teachers (or community artists, if a community project). Several designs could be developed and an election held amongst the student body for the most preferred, or a special panel could choose from amongst design submissions.

If the organizing class is an art class, or a class of another subject area but with students who happen to have artistic ability, then the organizers themselves could choose a theme, develop designs and hold an election for the preferred one. The election could involve the whole school, only art classes, or just the organizing class itself. The teacher,

organizing class, and school administration will have to select the best method for mural theme and design choice utilizing as much participation as is practical given the size, attitudes, and experience of the particular school body. The same decision concerning degree and method of participation will have to be made by student organizers, school and community officials, and community participants with regard to a community mural project. There are times that a gifted artist who senses the needs and history of a particular school or community can deliver an uplifting work without an involved participatory process.

Lesson #4

Aim: To develop a plan to procure the materials necessary to render the mural or public art project.

Motivation: How are we going to obtain materials for the mural?

Discussion:

Develop a fund-raising plan in terms of materials needed (paints, brushes, etc.), their cost, and the means of obtaining them. See Energy Conservation, Unit I, Project B (Solar Collector), Lesson #3, and this Unit, Project C (Anti-Graffiti Campaign), Lesson #3, in preparing a fundraising letter.

Followup:

Discuss with students the possibility of obtaining the equipment as a donation from a store or other source, for example, from school custodians, the art department, school industrial arts shops, local merchants, etc.

Lesson #5

Aim: To implement the mural project.

Motivation/Discussion:

Rendering a wall mural can be a very participatory activity in which even those who can't draw the proverbial straight line can be involved. The basic layout and organization of the mural on the wall needs to be done by an artist skilled in such an activity -- perhaps an art teacher, art student, or community artist. While the most intricate painting needs to be done by the skilled artist(s) who have developed the design and/or rendered the mural organization on the wall, the painting of certain areas can be done by other students/community residents.

Followup:

When the mural is completed, a ceremony involving as many representatives of the school and community as possible will add significance to the effort and help provide an additional emotional and spiritual bulwark against vandalism.

E. Other Ideas for Open Space Beautification Projects

There are some open space projects which have been well-laid out elsewhere and need no repetition here. For example:

a. Organizing a tree planting and care project--See "Plant a Tree for Arbor Day," Environmental Action Coalition and NYS Department of Environmental Conservation, 1985. To obtain a copy, call Environmental Action Coalition at 212/677-1601. Trees can and should be labeled (species, year and group involved in planting, etc.) as well, to inform others that the tree is important and in need of care.

b. Organizing a flower and shrub planting project and/or the planting of a whole garden on school or other grounds. See The Youth Gardening Book: A Complete Guide for Teachers, Parents, and Youth Leaders by Lynn Ocone with Eve Pranis. Also Grow Lab: A Complete Guide to Gardening in the Classroom, National Gardening Association, 180 Fifth Avenue, Burlington, Vermont 05401, 802-863-1308.

c. Building a model of an ideal park or playground. Contact the Council on the Environment of NYC at the address on this Curriculum for help with this.

d. Organizing a survey of citizens' attitudes toward use of a particular open space, with followup action based on survey results, e.g. more citizen clean-ups including painting of benches, patrols. See this Unit, Project B for overall survey steps and Auxiliary Materials following for general examples of park survey forms.

OPEN SPACE BEAUTIFICATION AND PRESERVATION UNIT -- The Projects

AUXILIARY MATERIALS

1. Park Survey form (based on CENYC/TSO materials).
2. Washington Square Park Playground Interviews and Observational Surveys (based on a project organized by City-As-School High School students, Manhattan, to assess parental evaluations of playground safety in the park, 1983-1984).

PARK SURVEY FORM

Name:
Date:

A. Activities / Use

1. While you were in the park, about how many people were using the park or passing through? _____
2. About how many of them were: 12 years or under? _____
13 to 20? _____
21 to 59 _____
60 or over? _____
3. List all the activities that you observed while in the park (for example: playing on swings, playing tag, reading, sleeping, etc.):

B. Natural Features

4. Please list the types of trees you've observed in the park:
5. What are some of the other types of plants you've seen:
6. What problems have you observed, regarding any trees, plants, or other natural features of the park:

C. Man-made Features

7. List the major types of equipment and facilities in the park:
8. What are some of the problems with these:

WASHINGTON SQUARE PARK PLAYGROUND INTERVIEW

Date and Times:

Name of CAS Student:

Location of Interview (Circle one): Main Playground, Mounds Play-
ground, Toddler Playground

Person Interviewed (Circle one): Parent or Guardian

- 1) How often do you come to this playground per week during the school year (when the weather is good)?
- 2) How often do you come to this playground per week during the summer (when the weather is good)?
- 3) How much time do you generally spend here per visit during summer (when the weather is good)?
- 4) How much time do you generally spend here per visit during the summer?
- 5) How many kids are with you today?
- 6) What are their ages?
- 7) What do you generally do while your kids are playing? (Probe: Aside from watching your kids, do you do anything else?)
- 8) Do you think this playground is a good place for your kids?
- 9) Do your kids enjoy themselves here?
- 10) What do you think of the playground equipment here?
- 11) Do you have any major reservations about (or problems with) the playground?
- 12) Do you have any major reservations about (or problems with) the park as a whole?

- 13) Would you have any suggestions for changing this playground?
- 14) Do you think there should be children's toilet facilities in the playground?
- 15) Do you feel this playground should be enlarged?
- 16) Do you ever use other playgrounds in the area? (How does this one compare with the others?)
- 17) Of all the playgrounds you've ever visited, is there one that's your favorite? Why?
- 18) Do you live near the park? On what street?

GENERAL OBSERVATION FORM-- WASHINGTON SQUARE PARK PLAYGROUNDS

Your name:

Age Guide

Date and time:

Weather:

Toddler 1-5

Playground: Main
Toddler
Mounds

Child 6-12

Teen 13-18

Adult 18+

Situate yourself either in or outside the playground, at a point where you can observe as much of the activity and equipment as possible. You may have to change positions several times during this observation. (If you must situate yourself in the playground, be as inconspicuous as possible, so that your presence does not disturb or change what is happening in the playground.) Concentrate on one area of the playground, and just watch what is going on. As you watch, please keep in mind the following issues:

- 1) What parts of the playground/equipment are used the most? Used least?
- 2) Is there a lack of equipment for certain age groups? Are there conflicts between age groups in the playground?
- 3) Are there any dangerous aspects to the design of the playground, or its equipment?
- 4) How is behavior in the playground affected by its general design? What patterns of activity do you see?

After you have observed for a while, write down in the space below your impressions of the playground, keeping in mind the above issues, and any other issues you feel are important. Use the age guide. Be specific in your observations, and make sure you describe clearly and carefully what section of the playground you are observing and what pieces of equipment. Record not only what you see, but any problems that could arise, and any changes you would like to see made. Use the bottom and the back of this sheet.

Equipment

Numbers/Ages

Comments/Problems

Washington Square Park Playground Observation

Age Guide

Your name:
Date and time:
Weather:

0-1 Baby
1-3 Toddler
4-6 Young Child
7-12 Older Child
12-18 Teen
18+ Adult

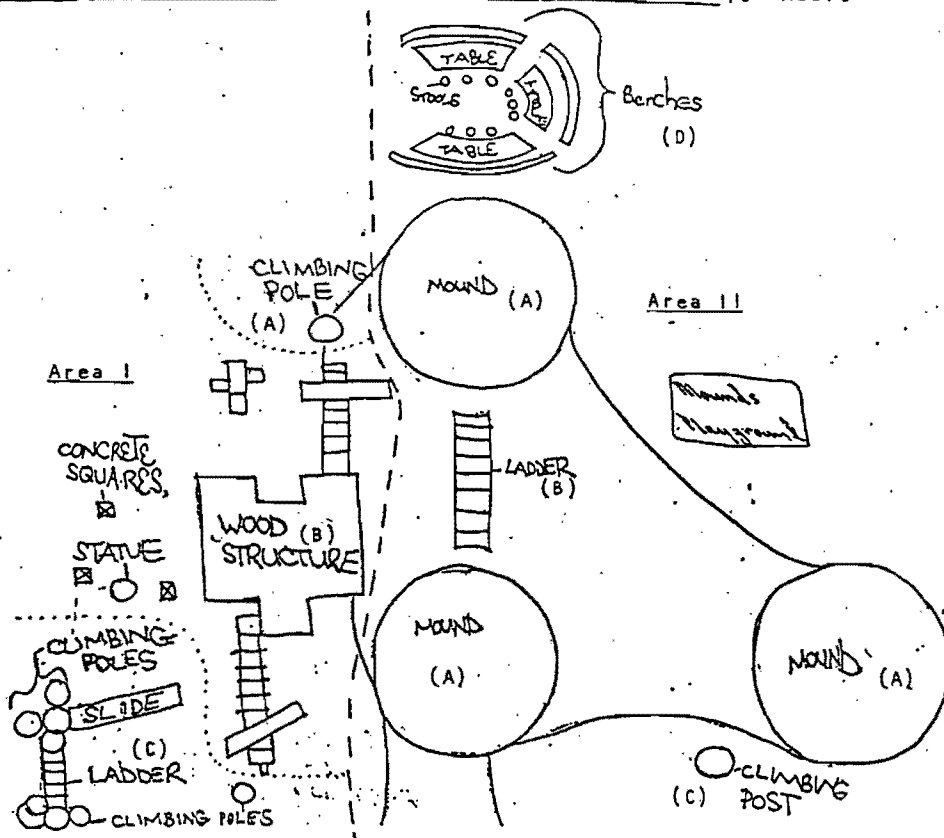

SECTION I

<u>Equipment</u>	<u>Numbers/Ages</u>	<u>Comments/Problems</u>
A- Climbing pole		
B- Wood climbing structure.		
C- Climbing poles, slide, and ladder		

SECTION II

<u>Equipment</u>	<u>Numbers/Ages</u>	<u>Comments/Problems</u>
A- Mounds		
B- Ladder		
C- Climbing post		
D- Circular benches and tables		

Age Guide

Washington Square Park Playground Observation

Your name:
Date and time:
Weather:

- 0-1 Baby
- 1-3 Toddler
- 4-6 Young Child
- 7-12 Older Child
- 12-18 Teen
- 18+ Adult

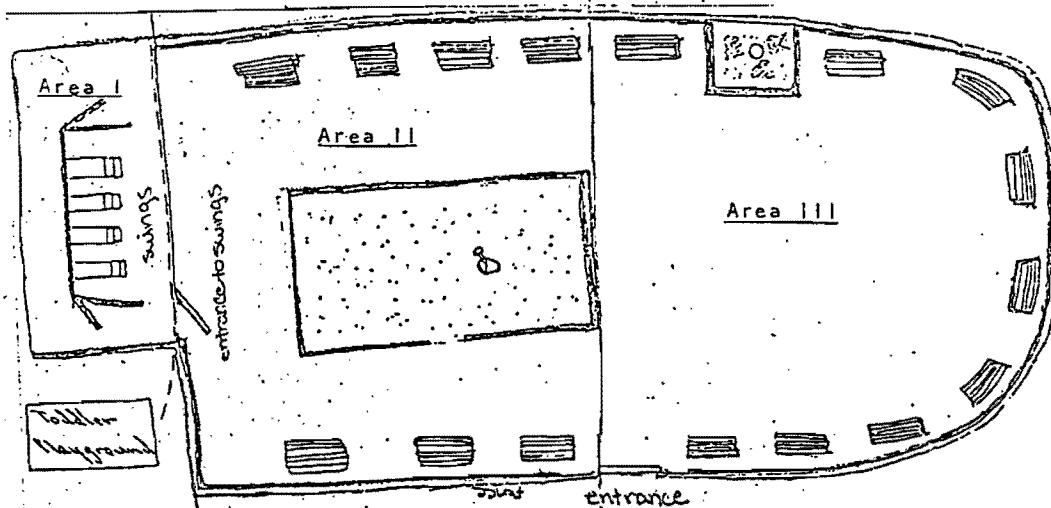

SECTION I

<u>Equipment</u>	<u>Numbers/Ages</u>	<u>Comments/Problems</u>
Swings		

SECTION II

<u>Equipment</u>	<u>Numbers/Ages</u>	<u>Comments/Problems</u>
Sandbox		

General area

SECTION III

<u>Equipment</u>	<u>Numbers/Ages</u>	<u>Comments/Problems</u>
General area		

REFERENCES

Graffiti

Hip Hop, Steven Hager, St. Martin's Press, New York, 1984.

Getting Up, Craig Castleman, MIT Press, Cambridge, MA, 1982.

Subway Art, Martha Cooper, Holt, Rinehart & Winston, New York, 1984.

The Handwriting on the Wall, Ernest L. Abel, Greenwood Press, Westport, Connecticut, 1977.

Tree Planting

The Care and Feeding of Trees, Richard C. Murphy, Crown, New York, 1983.

UNIT VI: NOISE POLLUTION

Introduction

Screeching subways, braking autos, blaring sirens, roaring airplanes and loud stereos are just some of the sounds that may injure your health. Sustained exposure to loud noise can lead to permanent or temporary hearing loss. Exposure to excessive noise can lead to high blood pressure, ulcers, emotional problems, sleep disruptions and learning disabilities. Noise is an insidious public health problem.

People need to be educated about the harmful effects of noise. Only then will they be willing to lower their radios and television sets, not honk automobile horns so frequently, and, in general, make less noise. Consumers could purchase goods that are less noisy and support manufacturers of quieter products. Companies could use tools that are quieter and could confine noisy construction to the waking hours.

Noise Pollution: The Issue

Lesson #1

Aim: To study the nature of sound and noise and the hearing process.

Motivation: What are the five most common sources of noise? Which are the loudest?

Discussion:

- a. What is sound?
- b. Explain that sound is created by the vibration of objects in air, which create sound waves in the air that reach the ear. Demonstrate this by making sound in the classroom. Use a tuning fork, have students clap their hands, etc. What's vibrating?
- c. How do we hear? (See diagrams in Auxiliary Materials after this unit.)
- d. How do we measure sound? (By a sound level meter; display one if available. Meter can often be purchased in electronics stores for about \$40.)
- e. What is noise? Noise: any loud, discordant, or disagreeable sound. (Source: Webster's New World Dictionary) We can also say that noise is sound that reaches decibel levels to which continuous long term exposure in a given environment is likely to cause hearing loss or other health problems in some people. Although there is some disagreement, 85 decibels is

often the level at which long term exposure to sound can cause health problems.

f. Why is noise harmful? (See articles in Auxiliary Materials section.)

Lesson #2

Aim: What are the health effects of noise?

Motivation: Do you know anyone whom you think may have lost their hearing due to exposure to noise?

Discussion:

a. The health effects of long term exposure to noise can be physiological, e.g., hearing loss, stress, circulatory problems (heart and blood pressure), prenatal and post-natal problems such as low birth weight and malfunctioning circulatory systems. We measure the physiological effects of noise using hearing tests, individual records and interviews.

b. The health effects can also be social/psychological: learning difficulties, conversational interference, sleep disturbances, irritability. Social/psychological effects are measured by reading scores, math tests, interviews, observations, and sound level meters.

Lesson #3

Aim: What is being done about noise pollution?

(Note: Noise regulations are local. The comments here refer to NYC. If possible, obtain a copy of your local noise ordinances, if any.)

Motivation: Are there any laws to control noise pollution?

Discussion:

The 1972 NYC Noise Code:

a. Prohibits certain kinds of noise in public places: amplifying devices, radios, tape recorders, horns honking, construction, equipment. Noise from construction is prohibited except from 7 AM to 6 PM, Monday through Friday, unless special permission is granted.

b. Sets up specific decibel levels for air conditioners and motor vehicles.

c. Sets up an enforcement arm, the Environmental Control Board. If there is a noise problem falling under the Code, the complainant calls the NYC Dept. of Environmental Protection, an inspector is sent, and if a violation is found, a notice is issued and the violator appears before the Environmental Control Board for a hearing and possible penalties.

d. The New York State Legislature passed the Rail Rapid Transit Noise Code in 1982 requiring a gradual lowering of noise levels on elevated trains and subways over a twelve year period.

Noise: The Projects

- A. Organizing a Letter-Writing and/or Petitioning Campaign to lower Noise Levels of Public Transportation Vehicles

Lesson #1

Aim: To measure noise from local transportation vehicles and other sources.

Motivation: Discuss field trip to measure noise levels. Lay out data sheets which will record decibel levels at particular locations from specific sources.

Discussion:

- a. Trip usually needs to be planned in advance depending on school/community.
- b. Use sound level meter. Only one is necessary, although 2-4 per class or group is optimum.
- c. Demonstrate how meters work.
- d. Take field trip.

Lesson #2

Aim: Developing letters and/or petitions.

Motivation: Were the levels we recorded on our field trip high? For which sources? What can we do about this problem?

Discussion:

- a. Use organizing model employed in Solid Waste and other units.
- b. See Legislative Action section in Part II of this curriculum and adapt introduction and lessons to your class/group and the noise issue.

c. See sample letters and petitions in Legislative Action section in Part II.

d. Have students write first draft of letters and/or petition statement.

Followup:

Correct letters for grammar and punctuation.

Lesson #3

Aim: To write final versions of letters and/or practice petitioning.

Motivation/Discussion:

a. Write final version of letters and address envelopes to officials or person in charge of entity creating the noise.

b. If petitioning, practice role-playing. Plan field trip to do petitioning among target population.

Lesson #4

Aim: To develop and practice presentations to motivate others to write letters. ¹⁰

Motivation: Is there anyone else you think would be interested in writing letters about noise? Let's list them. Develop an outreach plan. (See "Outreach" section of Part II if need be.)

Discussion:

a. How would we approach these groups?

b. What would our presentations consist of? See note on presentations in Part II.

c. Presentations should be no more than 5-10 minutes.

d. Let's do more role-playing.

Followup:

Each student or participant should write up a presentation and be prepared to role-play during next session.

¹⁰ This may or may not be realistic, depending upon educational/motivational level of the group.

Lesson #5

Aim: Finalizing the letter-writing and/or petitioning campaign.

Motivation/Discussion:

- a. Practice presentations if necessary.
- b. Divide responsibility based on outreach plan amongst class/group for giving presentations.
- c. Make sure the students' own letters and petitions have been completed and have or will be sent.
- d. Make arrangements for presentations to be made. Will require 1-2 weeks notice or more in some instances.
- e. Presentations given over period of time.
- f. Groups writing letters should, whenever possible, write them immediately following presentations. Letters should be collected at that time.
- g. Letters will be copied and sent by students.

B. Organizing Educational Presentations on Noise Pollution To Elementary, Junior High, or High School Classes

Lesson #1

Aim: To review the nature of sound, noise, and hearing; the health effects of noise; and what's being done about noise.

Motivation/Discussion:

Review Lessons 1, 2 and 3 in the issue section of this unit.

Lesson #2

Aim: To begin to develop a presentation on noise for elementary, junior high or high school classes.¹¹

Motivation: What sources of noise are important to other students, your own age or younger?

Discussion:

¹¹ It may be particularly difficult for high school students to speak to peers on this issue because of the prevalent preference among many teenagers for loud music and due to peer pressure to appear "cool", but presentations to younger children are rewarding for all concerned.

- a. Discuss loud radios, televisions, car alarms, motorcycles, and possible damage that they can cause, e.g., loss of sleep, irritability. These domestic and neighborhood sources of noise are probably the most meaningful to children and teenagers.
- b. Demonstrate noise sources like loud radios and measure noise levels with a sound level meter.
- c. Ask student participants if they think they can interest younger students (or students their own age) in the noise pollution problem.
- d. How would we go about it?

Followup:

Students may have already had experience giving presentations during projects on other issues. Whatever the case, ask them to prepare a 5-8 minute talk on noise pollution to whatever age group you feel is appropriate.

Lesson #3

Aim: To continue to develop an educational presentation on noise pollution.

Motivation/Discussion:

Develop, practice, and role-play presentations as discussed in previous projects, e.g. Unit I, Project A, Lesson #3, or Unit II, Project A, Lesson #4, and Lessons 4 and 5 from Project A in this unit. Explain that this is an educational strategy as defined by the organizing model mentioned in previous units. See section on presentations in Part II. Decide on class or groups to be outreached to. Develop posters on the ear and the hearing process and possibly a packet of materials to be left with teachers of classes to be contacted. Leave enough time to schedule presentations.

C. Organizing Noise Awareness Day

Lesson #1

Aim: To review the nature of sound and noise, hearing, the health effects of noise, what's being done about noise, and hazardous sources of domestic noise. See lessons in Issue section of this unit.

Motivation/Discussion:

Develop subject as in the issue section of this unit and in previous noise projects. Review may be done in one session or more time may be required.

Lesson #2

Aim: To begin organizing a Noise Awareness Day.

Motivation: What are the ways we can educate our community about noise pollution?

Discussion:

a. The various answers that may be given to the motivational questions -- flyering, petitioning, tabling, presentations to community groups -- can all be integrated into a special community event on noise.

b. Suggest such a community awareness day to the students/participants if it hasn't been mentioned.

c. Such a day, in addition to handing out information at a table, petitioning during the event, and giving out flyers and presentations prior to the event, would also include media outreach, interactions with community agencies and services, contact with elected officials, etc.

Followup:

Have students/participants develop an outreach plan, as demonstrated in Part II and/or in several previous projects.

Lesson #3

Aim: To continue organizing Noise Awareness Day.

Motivation/Discussion:

Place the day conceptually within the framework of the organizing model laid out in previous units. Noise Awareness Day is primarily an educational strategy using a variety of methods. Most of the steps to be taken in organizing Noise Awareness Day can be gleaned directly or indirectly from previous projects and/or from Part II. These steps will involve:

a. Flyers and posters to publicize the event in schools, stores, the community at large.

b. Press releases for media coverage if desired.

c. Presentations to elementary and junior high school students, high school students, community groups, etc.

d. Obtaining ear plugs, leaflets on noise pollution, etc. to hand out on the day.

e. Petitions to be signed at the table and by passersby on the surrounding streets.

f. Notice to public officials and the town or community board as a courtesy to gain their participation and to gain permission, if necessary, to use a street space for the table.

g. Of course, selecting the date for the awareness day prior to finalizing any of these steps.

In May 1983, Lafayette High School students collected 1200 signatures on petitions to Governor Cuomo asking for enforcement of the then recently enacted Rail Rapid Transit Code, handed out earplugs to 600 citizens to protect them from elevated train noise, handed out 1000 information flyers on noise pollution, and attracted media coverage on the noise issue from several local newspapers. Noise Awareness Day in Bensonhurst, Brooklyn was a great success and was the beginning of a three year campaign to get noise abatement equipment placed on elevated trains near the school and in other areas as well. Resilient rail fasteners, rubber-like neoprene pads which lower noise levels 3-5 decibels, were eventually put on the B-train near Lafayette and on other trains as well.

NOISE UNIT: The Projects

AUXILIARY MATERIALS

1. Article "Noise Poses a Growing Threat" on health effects of noise from New York Times.
2. Functional diagram of the ear.
3. Article on noise and adolescence.

Noise Poses a Growing Threat, Affecting Hearing and Behavior

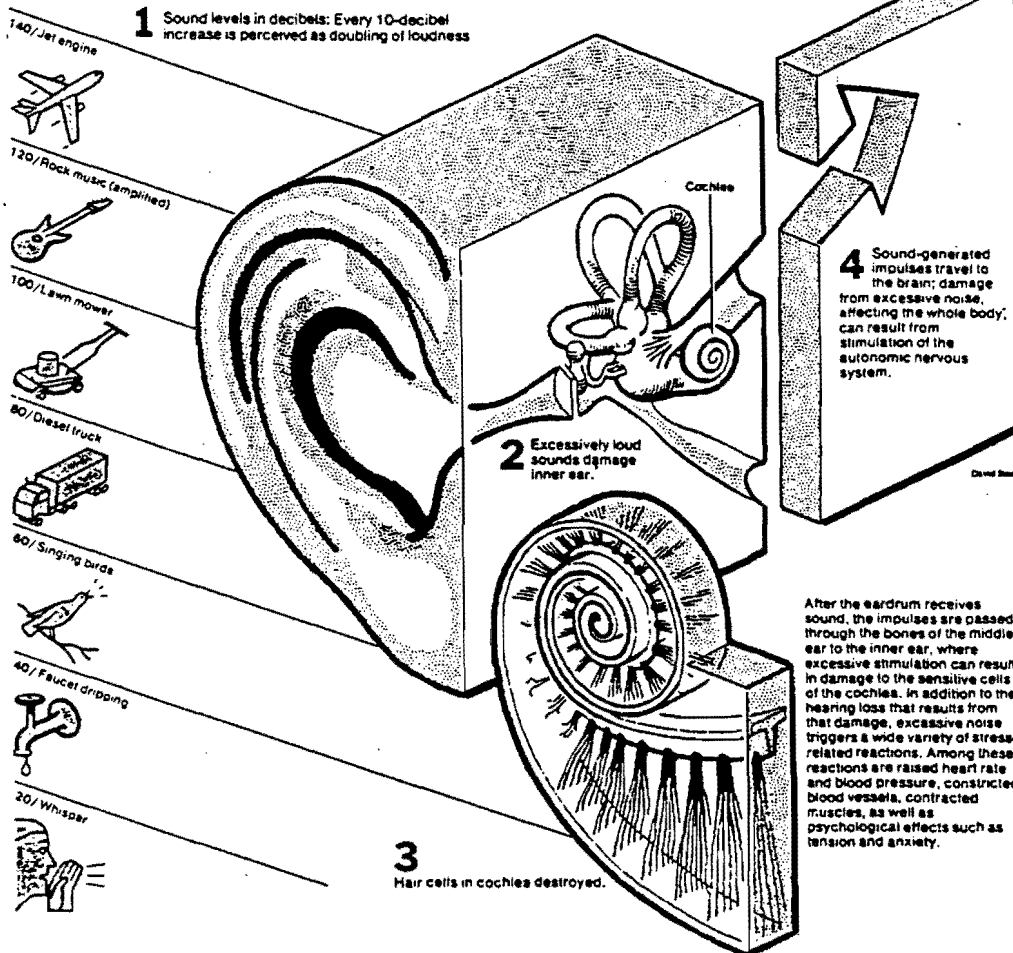

By JANE E. BRODY

IN trying to track a suspected Soviet submarine last month, the Swedish Navy had difficulty finding sailors who could hear well enough to operate the listening devices. The hearing of vast numbers of young people, a Navy captain said, apparently has been permanently damaged by years of listening to loud rock music.

Whether or not music is the culprit in Sweden, similar hearing losses have been noted among American high school and college students who are rock music aficionados or frequent discotheques, and hearing loss resulting from abusive noise has become a matter of pressing concern in this country, too.

For example, Dr. David Lipscomb, head of the noise laboratory at the University of Tennessee, recently found that more than 80 percent of 1,410 college freshmen had significant hearing loss in the high-frequency range, a deficit he believes is in-

creasing at an alarming rate. Just one year earlier he had found high-frequency hearing loss in 33 percent of the freshmen tested. He described the students as "two or three decades ahead of themselves in hearing deterioration."

A Japanese survey this year of 4,300 students revealed unexplained hearing difficulties in 29, 21 of whom were described as "headphone addicts." These 21 students listened to stereo headphones (Sony Walkmans and the like) for more than 24 hours a week at volumes that averaged 88 decibels, the approximate noise level of rush-hour traffic.

While noisy work environments have long been the focus of research and regulatory efforts, in recent years avocational noise has been attracting more attention. The explosive rise of noisy equipment in and out of American homes — ranging from snowmobiles, rock bands and chain saws to hair dryers, food processors and stereo headphones — has made nearly every American potentially vulnerable to noise damage.

The Environmental Protection Agency estimated

in 1978 that 10 million Americans are exposed to harmful levels of noise off the job. Other experts say this is a highly conservative figure. In addition to those who voluntarily expose themselves to high noise levels, such unwitting victims as premature infants in incubators, residents who live near airports and students whose classrooms abut train tracks may suffer noise damage.

And the damage incurred may involve far more than hearing acuity. Though more and better research is needed to define precisely the nonacoustical harm caused by noise, studies thus far suggest that noise stress can result in high blood pressure, cardiovascular injury, ulcers, and possibly even increased susceptibility to infection and reproductive problems. Other studies have pointed to noise-related learning difficulties, irritability, fatigue, reduced work efficiency, increased accidents and errors and socially undesirable behavior.

One series of experiments showed, for example, that passers-by were much less likely to help a

Continued on Page C3

Abusive Noise: Effects Are Physiological and Behavioral

Continued From Page C1

stranger who had dropped his books if there was a power lawn mower operating nearby than if the lawn mower's motor was turned off. In another experiment, angered subjects acted more aggressively after being exposed to noise that they could not control.

Such findings raise important questions about the possible contribution of noise to illness, antisocial behavior and interpersonal conflicts at a time when noise levels are increasing for millions of Americans. However, one leading investigator, Dr. Sheldon Cohen, a psychologist at Carnegie-Mellon Institute in Pittsburgh, says "there's very little research on the effects of noise being done in this country right now because the Administration has no interest in it."

Effects of Noise Stress

Last year, a committee of the National Academy of Sciences said that existing studies of the effects of noise on health suggested serious harm, especially to the cardiovascular system, and called for more careful investigation. The committee noted that the stress of noise "might alter the organism's capacity to withstand insults from other physical agents or environmental contaminants."

A number of findings have already been fairly well documented, including these:

¶Among at least 40 studies linking

noise exposure to increases in blood pressure, Dr. Ernest A. Peterson and colleagues at the University of Miami School of Medicine showed that monkeys developed sustained high blood pressure after being exposed for nine months to patterns and levels of noise that are frequently encountered by people. The noise levels studied were below those that can damage hearing.

¶Dr. Cohen and his former colleagues at the University of Oregon showed that children whose schools were along the flight path of Los Angeles International Airport had higher blood pressure than similar children attending quiet schools. The noise-affected children also had more difficulty solving puzzles and math problems and were quicker to give up in frustration. Furthermore, as time passed, no improvement was seen in the noise-related effects on the children's abilities.

¶High levels of noise in the home, from television sets, radios and other sources, were shown to disrupt the development of sensory and motor skills of children during the first two years of life. Babies living in noisy homes were slower to imitate adult actions and persisted in infantile habits longer than babies in quieter homes. Noise also delayed verbal development and exploratory behavior. The researcher, Dr. Theodore D. Wachs, a psychologist at Purdue University, believes that noise stress prompts babies to retreat into their own inner space.

¶A University of Wisconsin study

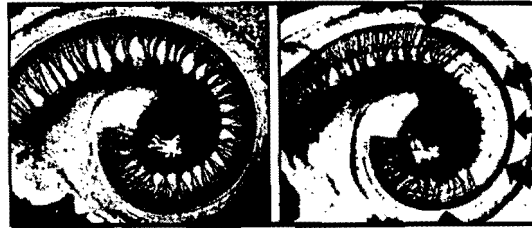

Sound-sensitive cochlea before damage and after, with cells destroyed

showed that noise produced in the home by arguing, shouting, vent fans, garbage disposals, electric mixers, knife sharpeners and running faucets produced a state of heightened body arousal and general nervous tension. Dr. Jack C. Westman, a Wisconsin psychiatrist, believes that home noise contributes to noise-related health damage and to conflicts between family members.

A series of European studies indicated that workers exposed to noise were more likely to develop abnormal heart rhythms, balance disturbances, circulatory ailments and ulcers. The workers complained more often of fatigue and irritability, and they reported more social conflicts on the job and at home. Studies in Britain and the United States suggested that people living in noisy areas, such as in

airport flight paths, suffered more emotional disturbances and required medical treatment more often than those living in quieter areas.

But according to Dr. Cohen and others, all these studies suffer from methodological problems, primarily the failure to take into account other factors, such as age, socioeconomic status and various on-the-job stresses, that could have influenced the effects attributed to noise.

Sound is measured in decibels, a scale that increases logarithmically. Zero decibels is the lowest level of sound that a young, healthy human ear can detect. A level of 140 decibels (a shotgun blast or jet takeoff) can be extremely painful. A rise of 10 decibels is perceived by the human ear as a doubling of loudness. The most frequently used decibel scale, called

dB(A), measures perceived loudness by giving more weight to high-frequency sounds, which seem louder to people than the same intensity of low-frequency sounds.

Injury Without Discomfort

Thus, the 100 dB sound of a power lawn mower or sawmobile is twice as loud as the 90 dB sound of a train roaring into a subway station. Dr. Maurice H. Miller, professor of audiology at New York University and chief audiological consultant at Lenox Hill Hospital and the New York City Department of Health, points out that noise well below the level of discomfort or pain can damage hearing.

Hearing loss will occur in 20 to 25 percent of workers exposed to the allowable limit of 90 decibels for eight hours a day (the loudness of street traffic or a heavy-duty truck). Under the newest Federal regulations, employers must establish hearing conservation programs for all workers regularly exposed to noise levels of 85 decibels or more.

Repeated exposure to loud noise destroys the delicate hair cells in the Organ of Corti, a part of the cochlea in the inner ear. These cells are responsible for picking up sound-induced pressure waves and transmitting them to nerve cells, which in turn carry them to the brain.

Sounds follow two paths into the brain. One path carries sound to the auditory center where it is perceived and interpreted. The other goes to an activating-regulating center in the

brain called the reticular formation and then on to the brain centers that turn on the autonomic nervous system. The latter path is responsible for the wide range of nonaural effects of noise because it calls into play the classic fight-or-flight response to stress: arousal, increased heart rate and blood pressure, constriction of small blood vessels in the extremities, redirection of blood flow away from the skin and digestive organs and to the brain and muscles, muscular contraction, release of stress-related hormones from the adrenal glands, dry mouth, dilated pupils and subjective feelings of tension, excitement and anxiety.

This stress reaction to sound is believed to be an evolutionary holdover from preindustrial times when loud sounds usually meant trouble — a roaring lion, falling rock or injured kinsman. The stress response enabled people to survive the danger by helping them either to run away or fight.

Noise researchers have found that most people get used to a sound that they hear often and know is not a cause for alarm, but their internal stress reaction continues unabated. Thus, if you live near train tracks, after a week or so you may no longer be awakened by passing trains. But internal reactions to the noise still occur and may eventually accumulate to cause bodily damage. Dr. Miller suggested that people who never become habituated to noise "may be better off because they tend to avoid noisy environments."

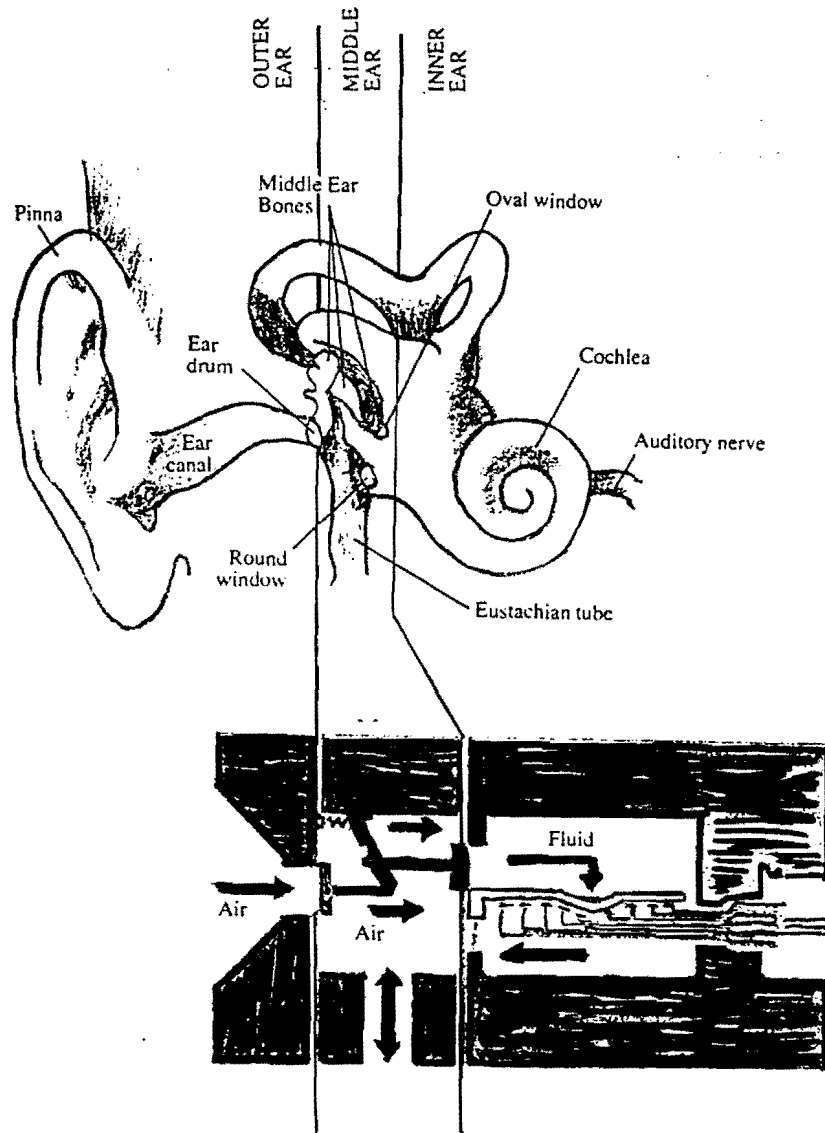

FIGURE 14.2

Functional diagram of the ear.

Sound waves impinge on outer ear and cause ear drum to vibrate. Vibrations are conducted via lever action of middle-ear bones (ossicles) to oval window, which actuates fluid-filled inner ear. Inner ear portion shows cross section of unrolled cochlea with nerve endings distributed along basilar membrane of cochlea.

Frequency-selective excitation initiates nerve impulses which are carried via discrete fibers of the auditory nerve to the brain.

SOURCE: Adapted from Cyril Harris, Handbook of Noise Control, 2d ed., (New York: McGraw-Hill, 1979)

From The Book of Health, American Health Foundation,
New York, 1981.

NOISE AND HEALTH: A WARNING TO ADOLESCENTS

Arline L. Bronzaft
Lehman College, City University of New York,
Bronx, New York 10468

Stephen B. Dobrow
Fairleigh Dickinson University

ABSTRACT

With many adolescents turning up the volume of their headsets, spending hours listening to loud music at discos and playing electronic games in extremely noisy arcades, and with a paucity of rigorous research on the relationship between noise and health for this age group, it is essential that we look at the impact of noise on their well-being. Yet, the growing body of literature, already noting the hazards of noise, calls for the development of strategies to warn our young people of noise's possible dangers and for enlisting their cooperation in quieting the environment for themselves as well as the rest of society.

When Rosen, et al. (1962) reported their data on the hearing levels of the Mabaan tribe of the Sudan, Americans learned that the older tribesmen of the Sudan had superior hearing than the twenty year old men living in our industrialized country. It was the quiet rural environment of the Sudan that was credited with producing the greater hearing sensitivity of the older inhabitants. The Rosen et al. data also revealed that the older Mabaan men and women did not differ in hearing ability. There were no sex differences in hearing thresholds in that noise-free society but in industrial societies where men are exposed to more intense sounds, Kryter (1985) reports that the hearing ability of older men have been found to be poorer than that of older women. Further examination of Rosen, et al. data revealed that the young Mabaans, between the ages of fifteen and thirty-five, before the start of presbycusis (hearing loss due to aging), had better hearing sensitivity than white people reared in industrialized societies. Thus, this study suggests that people reared in a noisy environment may experience the deleterious effects of noise while they are still young.

The Rosen study heightened the awareness of Americans to the danger that noise will induce hearing loss. An early response was the development of guidelines by the Department of Labor to restrict the number of hours people could work in noisy industrial plants of different noise levels. Thus, people could only work eight hours in plants that exposed them to 90 decibels and only two hours in areas measuring over 100 decibels. Should these industrial plants expose their workers to higher noise levels than allowed by law, workers had to be provided with ear protectors.

However, the government was slower in recognizing the possible dangers of noise to people who live in communities that are near airports, train tracks and highways. Their failure to lower the decibel levels of the equipment in-

Reprinted from *Children's Environments Quarterly*, Adolescence and the Environment, Vol. 5, No. 2, Summer 1988, pp. 40-45, Issue Editor Michael K. Conn. Published by Children's Environments Research Group, Ph.D. program in Psychology Environment, The Graduate School and University Center of the City University of New York, 33 W. 42nd St New York, New York, 10036, USA

stalled in cars, trains and airplanes resulted in communities developing near transportation areas being exposed to frequent, intense bursts of noise.

In response to growing concern about increased noise levels, the Noise Control Act of 1972 charged the Federal Environmental Protection Agency (EPA) with the responsibility of conducting research on noise and on setting noise limits for trains, trucks and machinery as well as recommending noise levels to the Federal Aviation Administration (FAA). Furthermore, the passage of the Quiet Communities Act in 1978 provided assistance to state and local governments in establishing noise abatement programs for communities. In its efforts to alert local government officials about the dangers of noise, the EPA published excellent educational materials which were distributed nationwide. However, the Reagan years sharply curtailed the federal noise arm of EPA. While the agency, in conjunction with the FAA, still sets emission standards for aircraft and still oversees noise limits for trucks, trains and machinery, it has essentially declared its educational and research programs a matter of state and local responsibility.

Cities, towns and villages have enacted their own anti-noise ordinances but enforcement of these ordinances has not received high priority, especially with the lack of interest expressed by the federal government. As an example, New York City has one of the best Noise Codes in the country but despite this stringent noise code, New York City appears to be getting noisier with each passing year. The New York City Department of Environmental Protection has no measures to support increased noise levels but does report an increase in noise complaints from 5,098 for the 1984 fiscal year to 8,153 for the 1988 fiscal year (Ross, 1988). Either the city is growing noisier or its citizens are more sensitive to noises and are registering more complaints.

IS NOISE DANGEROUS TO YOUR HEALTH?

While it has been generally accepted that hearing impairment is the major physical consequence of loud sounds, over 85 decibels, unwanted sounds, whether loud or soft (such sounds are often referred to as noise), can affect other parts of the body through stress. Continuous exposure to unwanted and uncontrollable noise in the workplace or at home, when such homes are in communities near airports, trains, and highways, can bring about the kind of stress and heightened arousal that has been found to result in cardiovascular and circulatory disorders (Kryter, 1985; Tempest, 1985). Higher admission rates to mental hospitals for people who live near noisy airports were also reported by some researchers

(Abey-Wickrama, a'Brook, Gattoni, & Herridge, 1969; Heridge & Chir, 1972) but the correlational nature of the data in these studies makes it difficult to ascertain whether the noise itself is the determining variable. Further study is needed to establish a relationship between mental health problems and noise.

Research has also hinted that even the unborn may be impacted by noise sources. Although the reports of lower birth weights and increased cases of birth defects such as cleft palates (Jones & Tauscher, 1978) amongst babies born to mothers who live near the Los Angeles airports need additional support, the U.S. National Research Council Report (1982) warns pregnant women to avoid working in noisy industrial settings.

While there appears to be general agreement that damage to hearing is the outstanding risk of prolonged exposure to noise, the available studies finding an adverse impact of noise on physiological and psychological well-being are less conclusive and more rigorous research is called for to confirm this conclusion.

NOISE INTERFERES WITH LEARNING

One area of interest to psychologists has been the impact of noise on children's learning. Noise effects are noticed as early as the time very young children are beginning to learn to talk and to explore their environment. Wachs (1982) has reported language and cognitive skills develop more slowly when children are reared in noisy homes. Wachs explains his findings by noting that there is less opportunity for children to interact with their parents in noisy environments. Pre-schoolers attending day-care centers near New York's elevated trains did poorer on psychomotor skills (Hambrick-Dixon, 1985) and similarly older children attending schools near New York's two major airports had lower reading scores than children in schools further from the noisy planes (Green, et al., 1982). Cohen, Glass and Singer (1973) have reported lower reading scores for children living near noisy highways and Cohen and his colleagues (1980) found children attending school near the Los Angeles airport had more difficulty solving cognitive problems.

In a study of a school where half the classes were adjacent to train tracks and the other half located at the quiet side of the building, it was found that second, fourth and sixth grade students on the noisy side were reading behind their counterparts on the quiet side (Bronzaft & McCarthy, 1975). The children in the sixth grade were as much as one year behind in reading. When the New York City transit authority was urged to install rubber pads on the tracks adjacent to the

school and the Board of Education was persuaded to install acoustic ceilings in the school's noisiest classrooms, the classrooms near the tracks were quieted by about six to eight decibels. A ten decibel decrease generally means cutting the sound level by half. A later study (Bronzaft, 1981) looked at the reading scores of the children on both sides of the building for two years after noise abatement materials were installed. The findings of this study showed no reading differences between children taking classes near the tracks and those on the other side of the building.

The many studies reporting a relationship between noise and lower scores in school were conducted on students below the seventh grade. One study on a teenage population, seventh and tenth grade students, (Maser, et al, 1978) found low academic students were affected by aircraft noise, whereas high academic students were not. This finding should not suggest that we disregard the learning environment for the better student and quiet the surroundings for the poorer student. The better student may have been able to perform well in the classroom despite the noise but his/her adaptation to the noise may have been costly to that student's well-being. We don't know whether the student was more fatigued after working in the noisy atmosphere or whether the student was more irritable after leaving the noisy classroom.

The importance of the above finding is that less capable students are being handicapped by noisy surroundings. For whatever reason, these students find it more difficult to learn in a noisy classroom. We could generalize from this finding and question whether less able students may find it more difficult to study in a noisy home. So many of our urban communities expose young people to extreme levels of noise in their homes and many of our schools are located on sites adjacent to elevated trains, highways, and airports. Even less urban areas expose students to noise as was discovered in a letter to the first author from a Virginian council member who complained about a school being located near a bus terminal.

Schools are noisy places even when there are no external sources of noise intruding on the classrooms. Teachers, administrators and students have long complained about noise within the school buildings, especially high schools. Certain classrooms, such as gymnasias and lunchrooms are very noisy. Internal sources of noise in schools include heating and ventilating equipment, poorly sealed doors, faulty electrical equipment duct work and high-ceilings where sounds readily reverberate. In response to their noisy environment, teachers often raise their voices and end up screaming. Such strain on the voice may cut down the teacher's effectiveness. To gain attention in schools, teachers resort to interruptive

noises such as bells, buzzers, whistles and other attention-getting devices. These only add to the already noisy environment.

In looking at studies examining student and teacher feelings about noise, Gifford (1987) concludes that students are distracted by social conversations in the classroom, that noise is more bothersome in crowded classrooms and that teachers may sacrifice good teaching methods for quieter, less effective ones in crowded classrooms. Gifford goes on to say that we have paid too little attention to the environment in which children learn. New York City's newly formed commission to rehabilitate school buildings is a recognition of the importance of this environment and, hopefully, noise control will be part of the commission's plans.

MORE NOISE—MORE AGGRESSION?

That noise affects social behavior can be seen from the many anecdotal reports of fights breaking out because a radio is playing too loudly or a noisy party is lasting past two in the morning. Laboratory studies have confirmed the relationship between aggression and noise. Geen and O'Neal (1969) and Donnerstein and Wilson (1976) found subjects were more likely to administer shocks under noise conditions. Subjects were not only more hostile, when exposed to noise, but were also less helpful as demonstrated in a field study when subjects hearing a lawnmower in the background didn't stop to help a confederate who had dropped his books (Mathews & Canon, 1975). Page (1977) also found people were less likely to help someone with a dropped package when jackhammers heightened the noise level of the area.

Noisy, overcrowded classrooms may also contribute to increased aggression as children who desire some quiet to work urge others to keep it quiet. It could be recommended that more studies be conducted relating elementary and high school aggression to noise, and such a recommendation is not being dismissed, but it would be far more beneficial to urge improvements in the school environment based upon the data of already published research.

IS OUR WORLD GROWING NOISIER?

Is the urban community becoming increasingly noisier? During the 1940's a brass bell on a firetruck could be heard in New York City but by the 1960's the siren had to reach 88 decibels to be heard and today many police cars use sirens of 122 decibels (Cherry, 1986). We also find support for smaller towns growing noisier. In writing her noise article for the Exxon USA magazine, Denise Zwicker (1986), who lives in a relatively quiet area of Houston, found she was intruded upon by low-flying helicopters, a teen-age rock band and a neighborhood motorcyclist. The U.S. Public Health Service surveys on the hearing ability of our citizens in 1960-62 and 1971-75 are discussed by Kryter (1985). He states that the agency found similar hearing ability for different age groups tested between the 1960 and 1970 periods. The Public Health Service data were collected a dozen years ago and noise levels have probably risen since that time. Today, we have headsets, large portable radios, loud stereos, and loud computer games which have contributed significantly to the

present day's higher noise levels. Therefore, it would be worthwhile to examine the hearing levels of our citizens over time to detect whether our apparently noisier world has led to increased hearing losses.

ADOLESCENTS AND NOISE EXPOSURE

Kryter (1985) also notes that the U.S. Public Health Service surveys reveal a gradual decline in hearing sensitivity with increasing age especially after the age of twenty and the difference between eleven and twenty year olds in hearing ability implied the trend downward probably started during the teen years. The USPHS data alerting us to the fact that loss of hearing due to everyday noises starts in our early teens is reinforced by Cozad, et al. (1974) who found from audiograms given to over 18,000 students, between the ages of six and eighteen, a "steady increase in the percentage of students having sensorineural hearing loss with age (6 to 18 years)." The loss was four times greater in boys than girls. David Lipscomb was quoted in the Cherry article that two-thirds of the more than 14,000 college freshmen he tested showed signs of some hearing loss. It was also learned that the New York City Police Academy rejected a number of fine recruits a few years ago because they scored poorly on the hearing test.

If our society is being exposed to increased noise levels, we might ask whether adolescents are more vulnerable. Dr. Marion Downs, professor emeritus at the University of Colorado of Medicine, and noted noise expert, was asked to testify at a U.S. Public Health Service hearing on health goals for the year 2000. She was quoted in the Rocky Mountain News as testifying "that baby boomers whose teen-age summers revolved around rock concerts aren't hearing as well as they used to, and their children are repeating their mistakes." (Newcomer, 1988).

Members of the New York League for the Hard of Hearing (Madell, 1986) stopped people on the street who were wearing headsets to measure the level at which they were listening to their headsets. The League reported that the majority of them were listening to sound that measured over 110 decibels. It should be noted that according to federal standards, exposing oneself to that level of sound for thirty minutes a day continuously, can cause some hearing loss. Unfortunately, Dr. Madell did not provide data on the number and ages of people surveyed nor did she gather information on the number of hours individuals listened to their headsets. In fact, she did not publish a paper on her findings. With headsets popular among teenagers as well as attendance at discos where sound levels reach over 120 decibels, there is reason to be concerned about hearing impairment in young people. It has been reported that rock groups playing in music establishments are exposed to 110 to 120 decibels for non-stop periods of up to 90 minutes (Lebo & Oliphant, 1968). Similarly, attendees to these clubs are also exposed to very loud sounds. It would indeed be very worthwhile to examine the probable health and/or developmental consequences of these noise exposures for adolescents.

Listening to and enjoying loud music is very much part of belonging to the teen culture. Youngsters who reject the loud sound are seen as outsiders. Suggestions to young people that

they should tune down the stereo are met with loud, negative reactions and those who ask for quieter sounds are looked upon as "old fogies." Residents complaining about music emanating from discos located near their homes are looked upon with disfavor by the people frequenting these establishments, especially the young attendees. It is especially difficult to convince youngsters that their hearing may be affected by their loud music when data to support hearing loss over time are scanty and young people are reluctant to worry about what will happen to them in the future. A guest on a late night program boasted how popular his rock music was and that he was making lots of money even though he was partially deaf. Rational people would question whether making so much money was worth losing one's hearing but young people would have probably turned a deaf ear to his statement of hearing loss.

When the Council on the Environment of New York City (Bronzaft & SantaMaria, 1984) asked catering halls in Brooklyn if patrons complain about the loud music played at parties, very few responded to the questionnaire; indicating that there are few complaints or that catering halls don't wish to be bothered with such a question. The Council had received complaints from older guests at such affairs that they were bombarded with sounds above 110 decibels but the young people for whom many of these parties are intended generally select the musicians and favor the loud music.

Another area where young people are exposing themselves to excessive noise levels is the electronic arcade. Visitors to such arcades can see people playing the games for hours at a time. Plakke (1983) found in his study of two arcades that certain games reach levels of 111 dBA. Also he found that operators set intensity levels of new games higher than those of older games to attract attention of potential players and kept them at maximum levels for several weeks. If teenagers visit arcades occasionally, there should be no concern for danger of hearing loss but there are reports that some teenagers spend days at these arcades. Research into this area is definitely needed.

Several New York magazines claim that high sound levels attract young people to restaurants. Apparently, the louder the sound, the more appealing the eating place. The noise, it is hypothesized, make the patrons feel exhilarated and alive. Such stories aim to associate noise with fun but also noise with acceptance and being "in." Noisy restaurants, like noisy discos promote the idea that the loud sound is enjoyable. Keeping in shape is being prompted around the country and, as a result, many fitness clubs and recreational centers have been set up. Attendance at these facilities where young people, as well as older ones, are working out will expose one to very high levels of music. It appears that we cannot stretch and bend unless we expose our ears to high decibel sounds. It would be very worthwhile to examine the social meeting places which rely on loud sounds to attract customers to determine whether adolescents are the more frequent patrons.

While all people suffer from vehicle and traffic noise, teenagers may suffer more than the general population. They drive cars which are older and generally noisier. Since noise is associated with a powerful engine, youngsters might purposely prefer a noisy car. The cars these teenagers drive

are less likely to be air-conditioned, so they are more subjected to traffic noise. Teens are now equipping their cars with high-powered "boom-boxes" which is adding to the noise levels of their vehicles. When they can't afford a car, they are likely to choose a motorscooter, motorbike or motorcycle—all of which expose the user to high noise levels, both from the vehicle itself and the traffic around them. We haven't measured the noise levels of teenager motor vehicles nor have we looked at the impact of this noise on their hearing ability and performance level in their cars. Such research is sadly lacking.

Those not old enough to handle motor vehicles travel by bicycle and are subject to traffic noise too. Some teens even add devices to the bike to produce noise; adding a playing card or baseball card with a spring clothespin which hits as the wheel goes around is a way teens have made noise for decades. Some scooters or ride-on vehicles come with noise-making devices as part of the original equipment. Sometimes the vehicle is used in a way that adds to the noise impact; for instance, some young people ride skateboards on their backs which brings their ears closer to the pavement where the noise is being produced. Again we call for research into the possible dangers of increased noise exposure for these young people.

Jobs available to adolescents tend to be limited and are often in "bad" environments. Many jobs are in fast food restaurants; these places tend to be crowded, hectic and noisy. Working as cashiers in department stores tend to subject workers to bells and jarring signals. Outdoor work is common for males. Doing gardening work subjects the user to the noise of equipment such as lawnmowers. Labor jobs on construction sites subject the worker to extremely high noise levels, often without the protection of ear mufflers. Working as delivery persons, whether by bicycle or motor vehicle, again places the worker in the midst of much noise. The Federal Occupational Safety and Health Act (OSHA) sets forth standards for permissible noise exposure levels in occupational settings but the code has not been applied as vigorously in the settings where teenagers are found holding jobs.

EDUCATING YOUNG PEOPLE ON THE POSSIBLE DANGERS OF NOISE

Even though we need more research to support the hypothesis that noise is dangerous to the physical, psychological, and social health of adolescents, existing data should justify the development of programs educating youngsters on the possible harmful effects of noise. In 1979, the Council on the Environment of New York City started a program to train high school and college students to organize environmental projects in their schools and communities. Council staff works with instructors in the participating schools and the students in the program learn about environmental issues and actively organize their communities to remedy some of the environmental problems such as the conservation of water, the conservation of energy and the beautification of their neighborhoods by creating gardens in empty lots. One of the interests of these students has been noise pollution. Students from several high schools in Brooklyn and the Bronx have engaged in letter-writing campaigns to quiet the

noisy elevated trains by hastening the transit authority's plans to install rail fasteners on tracks and ring-damped wheels on city subway cars. Students in a Brooklyn high school have collected signatures from their neighbors asking for better enforcement of the city's noise code, surveyed the community as to which are the most prevalent noise complaints, answered questions on noise on a local radio show and set up a panel of noise experts and community leaders to discuss the noise issue with residents of their neighborhood.

Student evaluations prepared for the Council on the Environment reveals that students learn much from their experiences in the environmental education program. In the 1985/86 school year, over 900 young people in 11 high schools and two colleges worked on 42 projects in the Bronx, Manhattan and Queens (Council on the Environment, 1986).

In the 1987-88 school year, the Council decided to enlist the cooperation of the Board of Education in educating elementary school children on the dangers of noise and provided the agency with 6,000 posters highlighting the dangers of noise to physical and mental health and suggesting ways to quiet noisy surroundings. These posters together with pamphlets entitled "Noise is more than a pain in the ear..." and lesson plans to assist teachers in their lectures on noise were sent to the Board. A health professor at Queens College, Dr. Madeline Hurster (1988) persuaded one of the school superintendents in Queens to set up assemblies discussing noise in several of her schools, hold health fairs in these schools, and get students to enter a poster contest on dangers of noise. Students in Dr. Hurster's health classes, who familiarized themselves with the noise literature, were responsible for lecturing to assemblies. So that they could reach children as young as five with their anti-noise materials, they developed clever and imaginative skits, often using puppets, to illustrate the dangers of noise and how children can suggest to others that they lower the decibel level. It is hoped that the college students will follow the advice about abating noise that they passed on so well to the public school children whom they lectured.

What better way to get adolescents to join in the battle against noise than to ask them to become participants in this effort? The Council plans to enlarge its environmental education program in more schools and Dr. Hurster hopes to act in a similar fashion. Persuading individuals, of all ages, to keep their stereos down, to respect the rights of others to quiet, and to urge their governments to enforce anti-noise legislation, is a difficult task because our society appears to care little about the auditory sense.

Convincing teenagers that they may be jeopardizing their hearing ability by listening to such loud music or possibly impairing their future health if they don't participate now in programs to quiet our towns and cities a bit is even more difficult. After all, what fun is a quiet party or a silent parade. We cannot become too preachy with the adolescent audience or we will find we have "turned them off and they have tuned us out." Rather, we must develop educational techniques that will serve to enlighten young people on the possible hazards of noise in a way that will lead to a protection of their ears if they plan to work in a noisy shop or attend a loud party. The methods employed by the Council

on the Environment of New York City should be extended nationwide. To this end, the Council has given interviews in the media describing their high school and elementary anti-noise programs and is planning to reach out to an even larger audience in the near future.

As an example of how teenagers can be taught about the potential harm of very loud headsets and the detrimental effect of noise on learning, a lesson plan in a high school setting could ask students to raise the level of their headsets very loudly until they feel uncomfortable and then students could be asked to take notes on an important lesson while listening to some very loud noise in the classroom. Such a lesson, given by a member of the Council on the Environment's noise committee to a local high school class not known for attentive students, did indeed gain its attention on the topic of noise.

The educational system itself must join in these anti-noise efforts by including material on noise pollution in their school curricula. New York State is revising its environmental educational materials and there will be some inclusion of information on noise. Similarly, book publishers writing in the environment field must include a section on noise.

PASSING AND ENFORCING LAWS TO PROTECT ADOLESCENTS FROM NOISE

Strategies must be developed to abate the impact of noise on adolescents. There are many opportunities to lower decibel levels of classrooms and local legislators must mandate efforts to quiet school environments. While there are standards to protect workers in industry, although not always met, there should be similar standards developed for recreational activities. For example, arcade owners should not be permitted to operate electronic games that raise the overall ambience level beyond 100 decibels. Discos should also be required to limit ambient sound levels. One might consider attaching warning levels to headsets.

CONCLUDING STATEMENTS

Thirty years ago smoking was associated with fun and researchers suggesting the relationship between smoking and health problems were looked upon with skepticism. Today noise is often associated with pleasure and enjoyment. Although the studies on the hazards of noise are not conclusive and more evidence is called for, and the possible greater harm to adolescents requires a solid data base, there appears to be more than a suggestion from the available research that noise is harmful physiologically and psychologically, that it leads to real losses in learning ability, and that noise hinders social relationships. At one time it was a sign of maturity to place a cigarette in your mouth and teenagers couldn't wait to start their smoking habit. Today, they know better. Let's not wait until all the data are in on the adverse effects of noise before educating teenagers on the hazards of excessive noise. Dr. Downs' warning about the baby boomers suffering from hearing loss stresses the need for aiming our environmental education programs at this age group now.

REFERENCES

- Abey-Wickrama, I., a'Brook, M.F., Gattoni, F.W.G. & Herridge, C. F. (1969). Mental hospital admissions and aircraft noise. *Lancet*, 2, 1275-1277.
- Bronzaft, A. L. (1981). The effect of a noise abatement program on reading ability. *Journal of Environmental Psychology*, 1, 215-222.
- Bronzaft, A. L., & McCarthy, D. P. (1981). The effect of elevated train noise on reading ability. *Environment and Behavior*, 7, 517-528.
- Bronzaft, A. L. & SantaMaria, C. (1984). Unpublished study. The Council on the Environment of New York.
- Cherry, L. (1986, December). The Hidden Menace to Your Health: Noise. *Glamour*, 168-172.
- Cohen, S., Evans, G. W., Krantz, D. S. & Stokols, D. (1980). Physiological, motivational, and cognitive effects of aircraft noise on children. *American Psychologist*, 35, 231-243.
- Cohen, S., Glass, D. C., & Singer, J. E. (1973). Apartment noise, auditory discrimination and reading ability in children. *Journal of Experimental and Social Psychology*, 9, 407-422.
- Council on the Environment, New York City. Annual Report, 1986.
- Cozad, R. L., Marston, L. & Joseph, D. (1974). Some implications regarding high frequency hearing loss in school-age children. *Journal of School Health*, 44, 92-96.
- Donnerstein, E. & Wilson, D. W. (1976). Effects of noise and perceived control on ongoing and subsequent aggressive behavior. *Journal of Personality and Social Psychology*, 34, 774-781.
- Geen, R. G. & O'Neal, E. C. (1969). Activation of cue-elicited aggression on general arousal. *Journal of Personality and Social Psychology*, 11, 289-292.
- Gifford, R. (1987). *Environmental Psychology*. Newton, Massachusetts: Allyn and Bacon, Inc.
- Green, K. B., Pasternak, B.S. & Shore, R. E. (1982). Effects of aircraft noise on reading ability of school-age children. *Archives of Environmental Health*, 37, 24-31.
- Hambrick-Dixon, P. J. (1985). Effects of experimentally imposed noise on task performance of Black children attending day care centers near elevated subway trains. *Developmental Psychology*, 22, 259-264.
- Herridge, C. F. & Chir, B. (1972). Aircraft noise and mental hospital admission. *Sound*, 6, 32-36.
- Hurster, M. (1988). Personal communication.
- Jones, F. N., & Tauscher, J. (1978). Residence under an airport landing pattern as a factor in teratism. *Archives of Environmental Health*, 33, 10-12.
- Kryter, K. D. (1985). *The Effects of Noise on Man*. Orlando, Florida: Academic Press.
- Lebo, C.P. & Oliphant, K.P. (1968). Music as a source of acoustical trauma. *Laryngoscope*, 78, 1211-1218.
- Madell, J. R. (1986). A report on noise. *Hearing Rehabilitation Quarterly*, 11, 4-13.
- Maser, A. L., Sorensen, P. H., Kryter, K. D., & Lukas, J. S. (1978, April). Effects of intrusive sound in classroom behavior: data from a successful lawsuit. Paper presented at the Western Psychological Association Conference.
- Mathews, K. E., & Canon, L. K. (1975). Environmental noise level as a determinant of helping behavior. *Journal of Personality & Social Psychology*, 32, 571-577.
- National Research Council. (1982). Report of Working Group, 85, Prenatal effects of exposure to high level noise. Washington, D.C.: National Academy Press.
- Newcomer, Kris. Rocky Mountain News, Denver Colorado, February 19, 1988.
- Page, R. A. (1977). Noise and helping behavior. *Environment and Behavior*, 9, 559-572.
- Plakke, B. L. (1983). Noise levels of electronic arcade games: a potential hearing hazard to children. *Ear and Hearing*, 4, 202-203.
- Rosen, S., Bergman, M., Plester, D., El-Mofty, A., & Satti, M. (1962). Presbycusis study of a relatively noise-free population in the Sudan. *Annual of Otolaryngology and Rhinology*, 71, 727-743.
- Ross, J. (1988). Personal communication.
- Tempest, W. (1985). *The Noise Handbook*. Orlando, Florida: Academic Press.
- Wachs, T. D. (1982, August). Relation of home noise-confusion to infant cognitive development. Paper presented at the American Psychological Association Conference.
- Zwicker, D. A. (1986). Nice news about noise. *Exxon, U.S.A.*, Second Quarter, 8-11.

REFERENCES

Engineering Acoustics and Noise Control, Conrad J. Hemond, Prentice Hall, Englewood Cliffs, NJ, 1983.

Environmental Noise Control, Edward B. Magrab, Wiley, New York, 1975.

Handbook of Industrial Noise Control, W. Graham Orr, Technology Transfer Division NASA, Washington, DC, 1981.

Noise and Society, M. Dylan Jones, and Anthony Chapman, eds., Wiley, Chichester, New York, 1984.

Noise Pollution, Shan Finney, and F. Watts, New York, 1984.

The Effects of Noise on Man, Karl D. Kryter, Academic Press, New York, 1970.

Urban Stress: Experiment on Noise and Social Stressors, Sand C. Glass, Academic Press, New York, 1972.

UNIT VII: NUCLEAR ENERGY

Introduction

John and Jane Smith drive home from work one summer evening. Jane unlocks the door and turns on the air conditioner to cool off the apartment. John pours two glasses of cold iced tea that have been chilling in the refrigerator, while Jane turns on the stereo. John places some frozen Mexican food in the microwave and prepares dinner as Jane sets the table. After dinner, Jane clears the table and, after rinsing, places the dishes in the dishwasher and runs them through the wash cycle. Afterwards, they turn off the stereo and turn on the television and VCR to watch a movie rented from the local video store. When the film is over, they turn off the VCR, watch the evening news, drink some espresso (made in their home espresso maker), turn off the light and television, and retire for the night.

This is a scene that is fairly typical to a varying degree, for many Americans. This standard of living requires great energy consumption. That which many in America consider a necessity is a luxury in most parts of the world.¹² The average American, to support him/herself in the style to which s/he has grown accustomed, needs twenty times as much energy than is available to an average citizen of an Asian country. Americans consume 24% of the world's energy supply each year. One of the technological means of meeting these demands is nuclear energy.

The United States during the Eisenhower Administration (1953-1960) began developing nuclear energy for peaceful consumer use in the "Atoms for Peace" program. The nuclear industry, with a promise of a source of clean, non-polluting energy, grew during the 1960s and early 1970s. The Arab oil embargo of 1973-74 spurred the nuclear industry.

Starting in 1979 with the Three Mile Island accident, the nuclear industry experienced setback after setback. The Three Mile Island accident energized a pro-solar energy consciousness and a growing anti-nuclear movement. The Soviet Union's Chernobyl disaster of 1986 seemed to toll the death knell for the industry. Yet in late 1988, the industry with assistance from the federal government, seemed to begin a resurgence. However, many significant questions have been raised by the public's consciousness of the dangers of nuclear power. Is nuclear energy a wise choice for America's and the world's energy future? Can the issues of nuclear waste transportation and disposal, plant

¹² With all of this, approximately 34,000,000 Americans, or over 14% of the population live below the officially designated poverty line.

and worker safety, plant construction and eventual decommissioning be resolved? Will further development of commercial nuclear power produce the nuclear waste which, when enriched, be used to provide material for nuclear weapons in a world where arms reduction seems essential? Presently, nuclear power provides about 19% of the electricity in the U.S. and about 5% of the overall energy supply. These questions must be adequately addressed before further commitment to nuclear power is made.

Nuclear Energy: The Issue

See Lesson #1 in Unit I, Energy, to be used here too.

Lesson #2

Aim: What are the advantages of nuclear energy?

Motivation: Why is nuclear energy promoted as a clean energy source?

Discussion:

a. Why is uranium desired as a fuel source? Uranium and other radioactive elements can emit enormous amounts of energy. A one-kilogram (2.2 pounds) clump of uranium, when used in a nuclear reactor, releases energy equivalent to that provided by the burning of 3,000 tons of coal in a conventional power plant. A source of radioactivity which emits energy spontaneously can supply as much heat as 10 tons of coal. Weight for weight, radium can yield 320,000 times as much energy as coal.

b. What are some of the atmospheric emissions of nuclear energy?

Nuclear energy, compared to oil and coal, emits little in the way of atmospheric pollutants. Nearly 80% of all air pollution in the U.S. is caused by fossil fuel combustion. About 95% of all sulfur oxides, 85% of all nitrogen oxides, and more than half of the carbon monoxide and particulates are the result of burning fossil fuels. 13

Lesson #3

Aim: What is radioactivity?

13 Source: For Lessons 2 and 3 is Air Pollution Primer, "The Special Pollution of Radioactivity," National Tuberculosis and Respiratory Disease Association, New York, 1969. Also for Lesson 2 is Energy: From Source to Use, H. Stephen Stoker, Spencer L. Seeger, and Robert L. Capener, Scott Foresman Glensview, 1975.

Motivation: What is the source of nuclear energy?

Discussion:

a. What is the structure of the atom?

An atom is the smallest unit of an element that retains the chemical characteristics of that element. The atom consists of a central nucleus (containing protons, neutrons, and other particles) surrounded by a cloud of electrons.

The distinctiveness of an atom of one element from that of another lies in the arrangement and number of electrons, protons, and neutrons. The negatively charged electrons are bound to the nucleus and are balanced by an equal number of positively charged protons. Neutrons carry no charge and are thus neutral.

b. What is atomic number and atomic weight?

Atomic number is the number of protons which is also the number of electrons. The atomic weight is the sum of the number of protons plus the number of neutrons.

c. What is radioactivity?

Radioactivity is the process by which a nucleus spontaneously gives off particles and/or energy.

d. What is radioactive decay?

It is the process by which one element changes to another element when its nuclei gives off particles. As radioactive decay occurs, the nuclei emit three different kinds of rays: alpha, beta, and gamma.

Alpha rays consist of a stream of positively charged particles, each consisting of two protons and two neutrons (a helium nucleus). Emission of an alpha particle lowers the atomic number by two and the atomic weight by four. Beta rays consist of streams of fast moving electrons (beta particles). A neutron is then converted to a proton. This adds one to the atomic number, but the atomic weight remains the same. Gamma emissions are the release of energy from a nucleus at the speed of light, usually, but not always, following alpha or beta decay.

Lesson #4

Aim: How does a nuclear power plant work?

Motivation: How is nuclear energy released?

Discussion:

a. What is the fission process?

Fission is the process of natural radioactivity. Elements with many protons tend to be unstable; that is, since they can more readily be remade into other elements by starting with unstable elements and constructing stable ones, vast amounts of energy can be released. Uranium, with an atomic number of 92, can be split into smaller atoms.

b. What are isotopes?

Isotopes are variations of an element that have the same atomic number as the element itself, but different atomic weights, and different radioactive behaviors. Radioactive isotopes are used in the fission process in power plants, medicine, science and industry.

c. How is power produced from the fission process?

In a nuclear energy plant, fission is produced by bombarding uranium, packed as ceramic pellets in rods, with neutrons. The uranium atoms then split into isotopes of krypton and barium with a resulting release of heat energy and neutrons. Neutrons are released so quickly that a moderator must slow them down. This increases the probability of them striking other fissionable material (critical mass) to create a self-sustaining reaction (chain reaction). Control rods (made of boron steel) control the rate of reaction. While rods are in the core, a reaction can't happen.

The fission process produces enormous amounts of heat energy which is absorbed by a coolant. The coolant (commonly water, air, or carbon dioxide) is the material that is circulated through the reactor to remove the large quantities of heat energy formed through the fission process. The heat of the coolant creates steam, the force of which turns the turbines which rotate the generator to produce electrical energy. The radioactive coolant is recirculated in a closed loop for further use. The steam is condensed to water, and the water too is recirculated.

Followup:

See Power Plant diagram in Auxiliary Materials section.

The primary sources of information for Lessons 4, 5 and 6 is Perspective on Energy: Issues, Ideas, and Environmental Dilemmas, ed. by Lon C. Ryedisili and Morris W. Firebaugh, Oxford University Press, New York, 1982. Also, Energy: From Source to Use, cited after Lesson 2.

Lesson #5

Aim: What is the nuclear fuel cycle?

Motivation: How is nuclear fuel produced?

Discussion:

a. What are the steps of the nuclear fuel cycle?

Uranium must go through a complicated process before it can be used as a nuclear fuel. This process is known as the nuclear fuel cycle and consists of eight steps:

- ▶ Uranium ore is mined and milled.
- ▶ Uranium oxide is extracted from the ore, refined, and chemically converted into gaseous uranium hexafluoride.
- ▶ The uranium hexafluoride is enriched to uranium 235.
- ▶ Enriched uranium hexafluoride is converted into appropriate fuel material, usually uranium oxide or carbide.
- ▶ Fuel elements are fabricated from fuel material.
- ▶ Fuel elements are used in a reactor.
- ▶ Spent fuel elements are reprocessed.
- ▶ Radioactive waste must be transported and disposed of safely.

b. What is fuel enrichment?

Uranium 235 is the fissionable material used in most reactors. However, this isotope accounts for only 0.72% of naturally occurring uranium; the remaining 99.28% is made of non-fissionable uranium 238. The fuel elements used in most reactors contain uranium oxide which has been enriched so that 2.5% - 3.5% of the uranium present is uranium 235.

Followup:

See Auxiliary Materials, Fuel Cycle process.

Lesson #6

Aim: How are nuclear wastes stored?

Motivation: What happens to nuclear wastes and how dangerous are they?

Discussion:

a. What are radioactive materials?

Radioactive materials come from hospitals, power plants, research labs, factories, and defense installations. When uranium and plutonium in nuclear fuel undergo fission, they produce other elements which are reactive but not useful for the production of energy. These elements become radioactive waste. This waste can also include clothing, paper, and instruments exposed to radioactivity. Since these wastes are very dangerous to human health, they must be carefully stored until their level of radiation falls to that of the natural environment.

b. What is a half-life?

Radioactive decay is measured in half-lives. A half-life is the time it takes for half of a sample of a particular isotope to decay into another isotope. For example, iodine 131 has a half-life of 8 days, while iodine 129 has a half-life of 15,900,000 years.

c. What is high-level radioactive waste?

High-level radioactive waste is the spent fuel from nuclear reactors. It is highly radioactive and must be stored for centuries. It is packaged in stainless steel tanks, or ceramic or metal blocks in which other non-radioactive solidified waste is mixed. As of now, there are no acceptable means of permanent disposal. Options that have been considered include burial in deep shafts in salt beds, or granite or basalt formations; burial beneath the sea bed in polar ice sheets; or space orbit.

d. What is low-level radioactive waste?

Low level radioactive waste consists of materials contaminated during the steps in the fuel cycle. These include rags, papers, filters, tools, and protective clothing. They require safe storage for up to 100 years. They are packaged in steel drums and wooden boxes. Disposal methods include storage at site, in above ground vaults, and shallow burial.

e. Why is radioactivity from nuclear materials so dangerous?

Radioactivity is dangerous because of ionization, which is the process by which an atom becomes electrically charged. This results when electrons are pulled off. The atom that lost the electrons becomes positively charged (positive ion) and the atom that gains them becomes negatively charged (negative ion). Radioactivity is dangerous because the rays can ionize the air through which they pass and any substance exposed to them. They can penetrate the human body and continue ionizing atoms within it, thus initiating a reaction that can end in damage to critical molecules of human cells. Radioactive decay cannot be shortened

in time or altered by temperature or pressure, so the danger of exposure exists as long as the decaying process exists -- i.e., depending upon the element's half-life, this condition might exist for thousands of years.

Followup:

What are positive uses of radioactivity? For example, X-rays to evaluate health, radiotherapy for the treatment of cancer and other diseases.

Nuclear Energy: The Projects

A. Organizing a letter-writing campaign concerning the transportation of radioactive wastes

Motivation/Discussion:

There is no need to outline the steps involved in organizing a letter-writing campaign with the students. Those have been spelled out on other issues on previous pages and in the letter writing section in Part II.

The transportation of radioactive waste is a nationwide issue since spent fuel from commercial nuclear power plants lies on site at the approximately 100 nuclear power plants in this country. No matter what the resolution of the debate over nuclear power, a safe long term solution needs to be found for the storage of nuclear wastes. Most proposed solutions involve some movement of the waste. Thus, safe transportation is essential since the 100 plants are all over the United States and their wastes may end up rolling along some of this country's most well-traveled highways.

Radioactive wastes from a research nuclear reactor based at the Brookhaven National Laboratory in Long Island, New York, have been trucked through New York intermittently for the past few years. The trucking of this waste was stopped by legal means in the mid-1970s and proceeded again in the mid 80s after a protracted legal struggle between the City's Department of Health, and Brookhaven, which is under the auspices of the Department of Energy and Associated Universities Incorporated. The City has insisted for years that nuclear waste should not be trucked through the most populated metropolis in the country (on its way to a reprocessing facility in Idaho) when an acceptable alternative exists: barging the wastes down the Atlantic coast to a reprocessing facility in South Carolina. Brookhaven claimed the barging alternative was too expensive and that the trucking is safe. The implications for trucking high level spent fuel from commercial reactors throughout the U.S. over our most used roadways and through our most populated cities are obvious.

While improvements have been made in the trucking casks and the trucks themselves, there is heated debate over the ability of the storage casks to withstand an accident and the effects of a spill of spent radioactive fuel in transport. In the New York City case, Brookhaven felt an accident would affect an area only 30 feet around the truck, while the City's Bureau of Radiation Control estimated that a 1% leak could cause 10,000 immediate deaths.

In 1985 and 1986, students from many of the high schools in the Council on the Environment's Training Students Organizers (TSO) Program wrote letters to United States Senators Moynihan and D'Amato, and to their congressional representatives asking that localities with over 50,000 population be given jurisdiction over whether hazardous materials can be transported through their environs. Over 600 letters accompanied by nearly 5000 names on petitions were sent. The letters generated significant response with several congressional representatives promising to monitor the situation and press for more acceptable solutions to waste transport.

It must be made clear that all points of view were presented to the students during the teaching process connected to action on this issue. Speakers were brought in on all sides of the issue. While the majority of student letters leaned toward finding a more acceptable alternative to trucking nuclear wastes through the nation's most populated city, students expressed many different points of view and shades of opinion on the issue.

Followup:

Have students organize a debate on nuclear power covering issues of waste transportation, costs, worker safety, accidents, etc. Have students make presentations to their classmates and other students in the school describing all sides of the issues. A panel of experts can judge the debate with press coverage highlighting the debate in the community. The debate can be turned into a nuclear "congress" in which "blocs" of students support or disagree with various presentations made by the debaters. Representatives of the blocs can give their opinions and the "congress" can develop a platform with various planks on nuclear power based on group votes. Again, local press coverage can highlight the issue to the local community.

What is the potential and actual relationship between nuclear waste and nuclear weapons? Explore this. All sorts of projects, including letters, petitions, debates, presentations, etc., can be organized around arms control issues in general, and their relationship to nuclear waste disposal in particular. Contact Educators for Social Responsibility to get support for these efforts.

NUCLEAR ENERGY UNIT -- The Projects

AUXILIARY MATERIAL

1. Diagram of How Electricity Is Made in a Power Plant,
with Nuclear Power Plant inset
2. Diagram of Fuel Cycle options

FIGURE 3 How Electricity Is Made* With nuclear power plant in inset.**

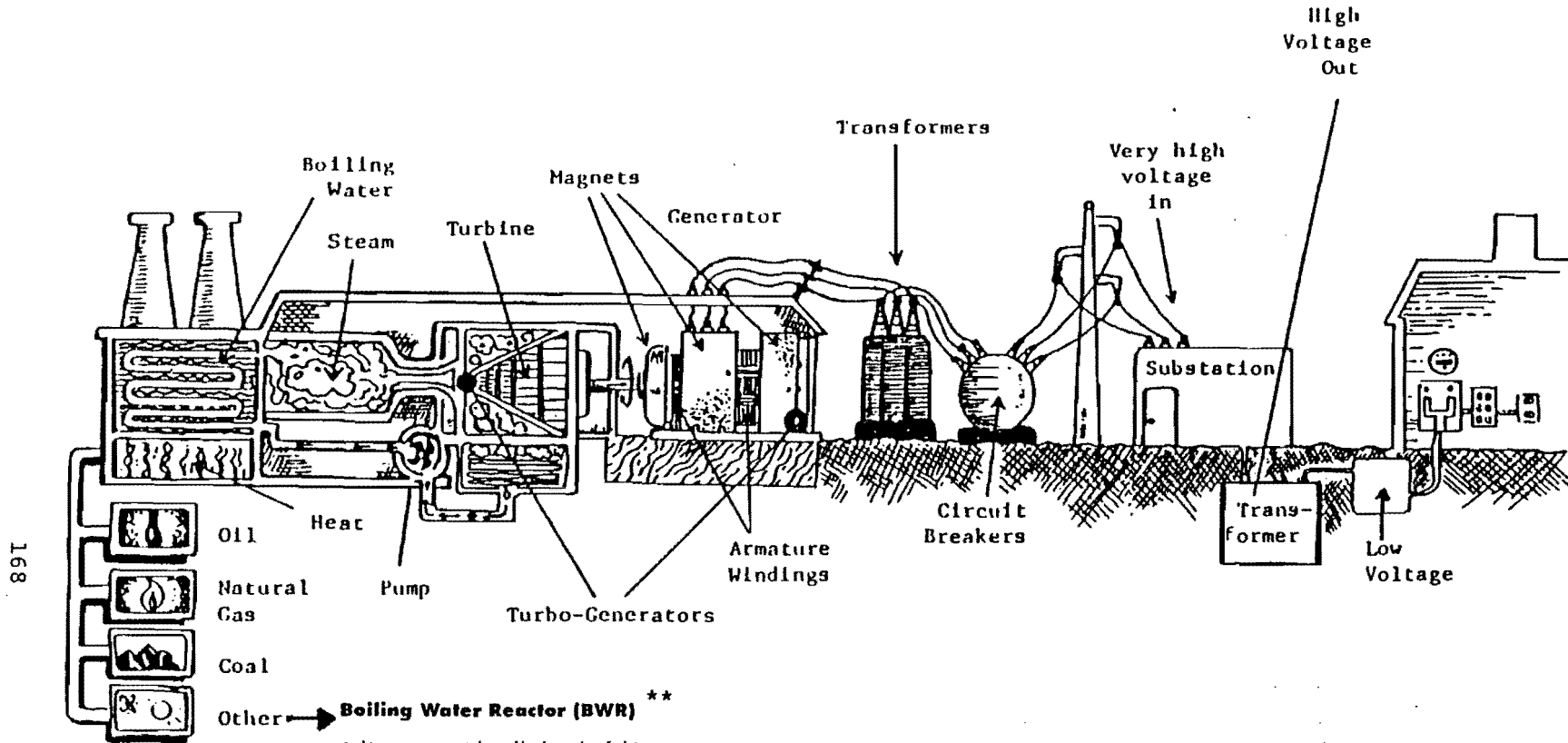

168

Boiling Water Reactor (BWR) **
 In this reactor, water is heated by the nuclear fuel. It turns to steam in the pressure vessel and is piped directly to the turbine.

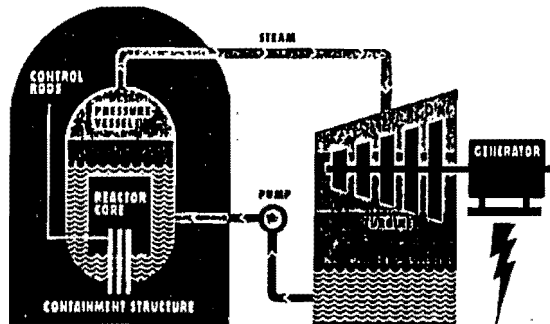

* Adapted from "Using Electricity Safely in Your Home", Consumer Affairs Dept., Consolidated Edison, New York, 1976.
 ** U.S. Council for Energy Awareness
 1776 I St., NW, Washington, DC 20006-2495

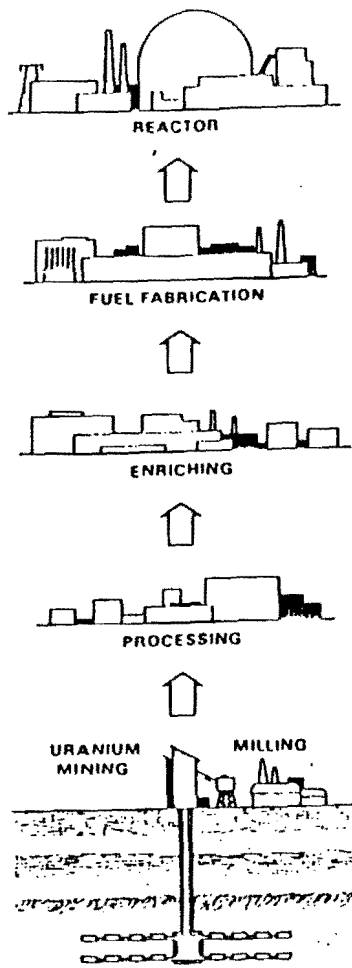

(Source: U.S. Department of Energy, 1979, 1.2.)

Major steps of the once-through fuel cycle option.

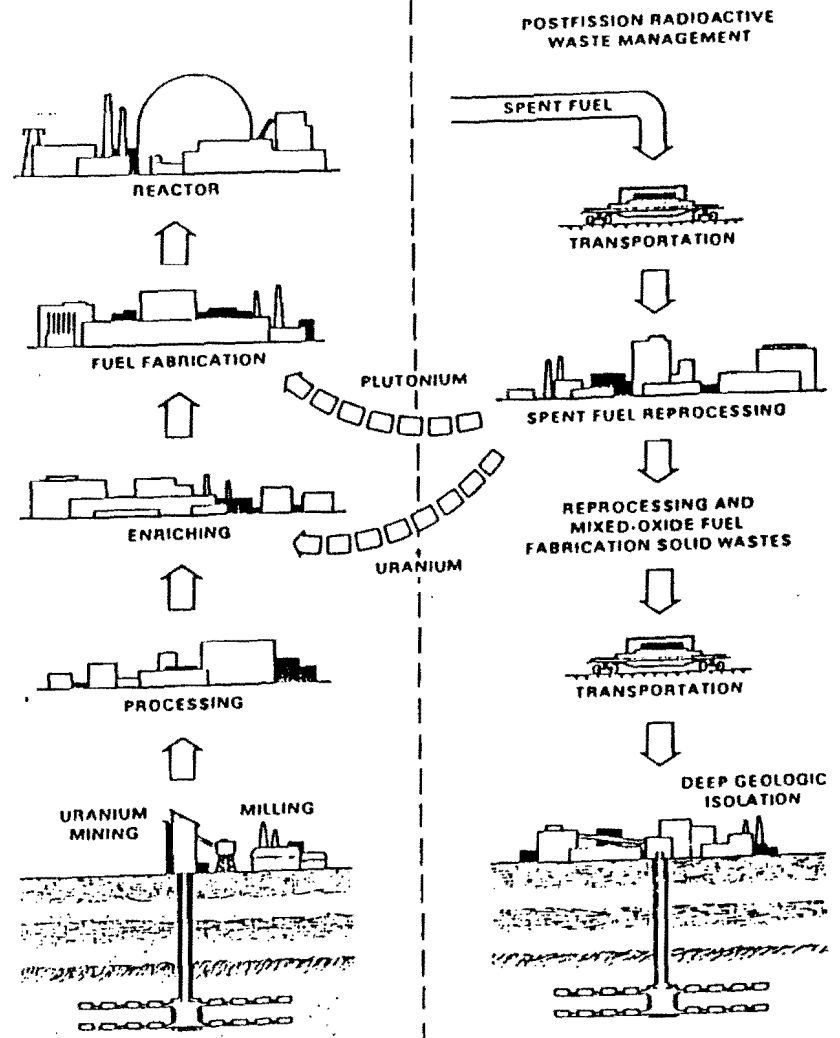
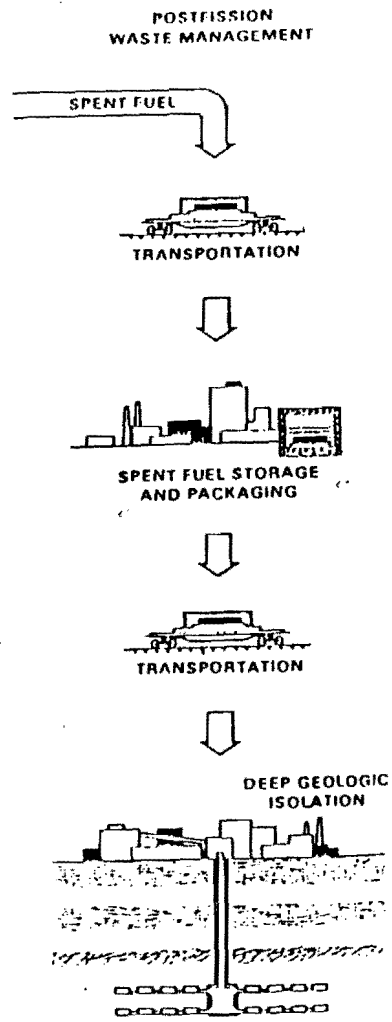

(Source: U.S. Department of Energy, 1979, 1.3.)

Major steps of the uranium and plutonium fuel recycle option.

REFERENCES

Living Without Landfills, Marvin Resnikoff, Radioactive Waste Campaign, 1987.

Non-Nuclear Future, Amory B. Lovins, Harper Colophon Books, 1984.

The Cult of the Atom, Daniel Ford, Simon & Schuster, 1984.

The Nuclear Waste Primer, The League of Women Voters Education Fund.

The Plutonium Business and The Spread of the Bomb, Walter C. Patterson, Sierra Club Books, 1984.

Surveying the Radioactive Waste Dilemma, Public Citizen Critical Mass Energy Project, 7215 Pennsylvania Ave. SE, Washington, DC 20003

We Almost Lost Detroit, John G. Fuller, Ballantine Books, New York, 1976.

UNIT VIII: TRANSPORTATION

Introduction

The transportation system of any city -- from complex underground subway systems to high speed maglev rail cars,, from yellow school buses to automobile clogged highways and road, from commuter ferryboats to bicycle paths -- is a major part of the infrastructure of that city. The success of the transportation system is an important factor in determining the degree to which a city is considered liveable.

The transportation system of a city does far more than serve its inhabitants. As the city grows, either in geographic area or population size, we can actually improve our way of life and transform the city to fit our needs by carefully designing, redesigning and expanding the transportation system. Conversely, as the transportation system of a city decays or becomes inadequate, we may find ourselves erecting barriers to the future growth of our city, frustrating the present working and residential population of the city, and deterring the influx of newcomers.

Attention to the transportation system will not be merely to improve the existing quality of life, but to form the city of the future as we would like to see it. In the long run, "the city is in size, in function and in form what the transportation system that was willed upon it allows it to be." ¹⁴

Transportation: The Issue

Lesson #1

Aim: To determine all possible modes of transportation in our city or town.

Motivation: One if by land, two if by air, three if by sea -- are there really that many ways to move around in our city or town? Most of us tend to rely on no more than three modes of transportation, but in reality there are many more options than that. In fact, some of what we may do for recreation, from bicycles to roller skates, can be everyday transportation for some folks. Try to generate a list of all the forms of transportation in your city or town.

Discussion:

¹⁴ Reference (for quotes and entire introduction) "The American City -- A Forecast" by Edgardo Contini from Readings in Ecology, Energy and Human Society: Contemporary Perspectives, 1977-1978 edition, Harper & Row Publishers, New York.

a. Some forms of transportation are more popular than others. Why? Might the weather, our degree of physical fitness, or the price have something to do with this? Try to identify these factors.

b. There are also environmental factors associated with each type of transportation:

- ▶ fuel economy
- ▶ air pollution
- ▶ noise
- ▶ anything else?

c. Now take your list of transportation forms (from the Motivation section of this lesson) and assign them numbers, perhaps from 1 to 10, based on their environmental impact. Something like a bicycle or walking should score a ten, while driving an eight-cylinder car with no passengers into the city might get a 1.

d. Look at your ratings. Do these numbers match the popularity ratings of the various transportation forms?

e. Do you think environmental impact has much of a bearing on people's choice of transportation?

Followup:

* What might be done to encourage some of the forms of transportation that have a high environmental rating?

* What might be done to encourage some of the transportation methods which have a good rating? What would encourage bicycling?

Lesson #2

Aim: To see the role of transportation in our own lives.

Motivation: "We are generally willing to dedicate a certain share of our time to travelling to and from work (or school). This amount of time is between one-half hour and one hour each way, and this time period has been constant pretty much throughout history." Edgar Contini (reference, page 1)

Discussion:

a. How long does it take you to get to work (school) one way? If members of your family work, how long a commute do they have? Is this between the half hour and one hour historical

average? Let's take an average for the entire class. How does it compare?

b. If you use more than one mode of transportation to get to school, make a list of each mode and the time spent on each. Which parts of your trip are most comfortable? Which parts need improvement? Could you think of an alternate way to travel that would reduce your environmental impact? What is stopping you from making that change?

Lesson #3

Aim: To consider future modes of transportation.

Motivation: Transportation systems have the dual purpose of moving finished goods and raw materials as well as people. With this in mind, try to think of the transportation systems that may have once served our city/town.

Discussion:

a. What modes of transportation originally served to get goods and materials to and from the city or town?

- ▶ River sloops
- ▶ Freight railroads
- ▶ Ocean cargo ships

Are any of these still in use? If they are not in use, what caused their demise?

b. What modes of transportation originally served the people of the city/town?

- ▶ Trolley cars
- ▶ Horse and buggy

Why are these no longer in use? New York City grew explosively when the street car and, later, the subway made it possible to go further during the same three-quarters of an hour of commuting time, and so the city grew in size and population from 400,000 to 4,000,000 to 8,000,000 during the first forty years of the twentieth century.

c. What might be some possibilities for future replacement of our present transportation system?

- ▶ Maglev rail cars
- ▶ Methanol powered buses
- ▶ Natural gas powered buses
- ▶ Electric cars

- ▶ High speed ferries
- ▶ More bicycle routes

Followup

Research the transportation systems of a few major international cities. What aspects of these systems might you recommend for your city/town? Are any of these systems/ideas in the research and development stages for your city/town? Phone or write the transportation department about this.

Lesson #4

Aim: To pinpoint needed improvements in the transportation system.

Motivation: In the last three lessons we looked at our own transportation systems and some possibilities for the future. In some cases we had specific complaints, obvious targets for improvement, and ideas about better transportation systems for the future.

Try to recall these complaints, the improvements, and possible systems for tomorrow. List these on the board. They will become helpful in the transportation action projects.

Discussion: Now that our ideas are on the board, what would be necessary to implement them? If we could demonstrate public support for such changes, they might well become a reality.

Transportation: The Projects

A. Organizing a Survey of Users' Attitudes Toward Their Transit System

Lesson #1

Aim: To evaluate one's own experience on a transit system.

Motivation: Have each student maintain a personal journal of their daily experiences on all the transportation systems they use. This includes foot, bike, bus, car, train, etc. Each entry should include time spent on the mode of transportation, distance covered (in blocks or fractions of mile), purpose of the trip and a rating for energy conservation.

Discussion:

- a. What common problems are cited?

- b. Are they most common on certain bus or train lines? At certain times? Or in one particular neighborhood?
- c. Is the trip worth the price?
- d. How much is it worth?
- e. Do alternative modes of transport exist?

Followup:

Students might try to substitute, on a trial basis, a travel mode of reduced environmental impact and record their findings.

Lesson #2

Aim: To understand who runs and finances a transportation system.

Motivation: Invite a speaker into the classroom from a city or town agency responsible for transportation.

Discussion:

- a. Who owns and operates the system?
- b. Does this agency operate at a profit or loss?
- c. Is the system subsidized?

According to one well-known city planner: "No system ever paid its way through collection of fares. We must recognize the value increases that a transportation system creates in the community, and use the value increases to fund the system itself." Edgardo Contini. (Source, see p. 171)

- d. What major improvements or maintenance projects are planned? Who will finance them?

Lesson #3

Aim: To select a survey site.

Motivation: Display maps of the city/town's transit system.

Discussion:

- a. Which places of exit and entry serve as main terminals or commuter hubs?
- b. When are these centers busiest?
- c. Is the area residential or business?
- d. Would it be best to survey persons en route to work or to home?

Lesson #4

Aim: To develop the survey.

Motivation: Divide class into teams with a minimum of five per team. Give students most of a class session to generate possible survey questions. Each team must appoint a representative to present the chosen questions to the rest of the class.

Discussion:

What types of answers can be most easily tabulated? (Consider "yes" and "no," number rating systems, etc.)

Lesson #5 (See FDR High School transportation survey in Auxiliary Materials section, pp. 181)

Aim: To role play the survey.

Motivation: Assign one half of the class as student surveyors, the others as commuters/respondents. Random pairs should role play the survey in front of the class.

Discussion:

Are there any mechanics of the survey sheet that should be changed based on this experience at role play? Should any questions be reworded, reordered, eliminated, or added?

Lesson #6

Aim: Planning to conduct the survey.

- a. Date, time, place of survey.
- b. How many copies will be needed?
- c. Should students wear name tags?
- d. Will literature be distributed?
- e. To whom might you deliver the results?
- f. Would a press release to highlight the process and/or results be appropriate?

Followup:

Compute results and prepare a brief report. Send it to the local transportation agency and interested organizations.

B. Organizing a Survey on Citizen Attitudes Toward a Roadway Project

Lesson #1

Aim: To understand why a particular roadway project has been proposed.

Motivation: Generate a list of pros and cons for the roadway project.

Discussion:

a. What is the history of that roadway? What changes have taken place such as widening, re-routing, replacement of the road?

b. To what degree does mass transit fill the transportation needs that could be filled by that roadway?

Lesson #2

Aim: To hear detailed explanations for implementing or not implementing the roadway project.

Motivation: Speakers for and against the project.

Discussion:

a. Could/should the proposal be altered in some way to satisfy both sides?

b. What additional requirements might be demanded if the project were permitted to proceed? (e.g., creation of park lands alongside, planting of trees and shrub barriers, re-route roadway to less sensitive areas, elevate roadway or tunnel dividers to reduce the number of animals killed while crossing).

Lesson #3

Aim: To compare private automobile travel to mass transit.

Motivation: Public bus and subway systems typically move greater numbers of people for less money, less air pollution, and often less time delay than comparable expenditures on private auto travel.

Discussion:

a. If the funds for roadway improvements were given to mass transit, what would be the magnitude of the improvements in terms of people served and energy saved?

b. How many more people would benefit?

Lesson #4

Aim: Survey citizens about the roadway project.

Motivation: Have the students generate key survey questions. (See "To develop the survey" Lesson #4, Project A.)

Discussion: Proceed through the survey development, role play and survey implementation steps as in the previous project. Also disseminate survey results as in the Followup of Project A. See Martin Luther King Jr. High School Westway survey in Auxiliary Materials section, pp. 182-183.

Followup: (depending on students' opinions and survey results)

- * Petition drive
- * Letter writing

C. To Promote an Alternative Transportation System
(e.g., Bike Paths,, Pedestrian Malls, Walkways)

Lesson #1

Aim: To determine the physical, social and legal barriers to bicycling and walking in the city/town.

Motivation: Bicycling and walking are good for health and also can get people back and forth to work and school. They depend upon human caloric energy as opposed to the burning of fossil fuels, thus they do not cause pollution. Where and when feasible, more people should bicycle and/or walk to work.

Discussion:

- a. Why don't more people bike or ride?
- b. Are bicycles or pedestrians allowed on bridges in your locality?
- c. Are there automobile-free areas in the city or town? Pedestrian malls?
- d. Are bicycles banned in any areas?
- e. Are bicycles allowed in trains? When?

Followup: Invite a speaker from a local bicycle club.

Lesson #2

Aim: To remove obstacles to environmentally sound transportation.

Motivation: Class trip to experience obstacles referred to above first hand.

Discussion:

- a. What will be required to remove/alter obstacles?
- b. Who can we target for a letter-writing campaign? For a petition? For leafletting?
- c. What can be done to generate public support for "our changes?" Are there existing citizens groups to whom the campaign might be attractive?

Example: In Montreal, Canada, bicyclists have been involved in a "velorution," which they describe as "the struggle of the bicyclists and other non-motorized travelers against the overwhelming domination of the automobile, the 'autocracy.'" Their efforts were concentrated on re-opening a bicycle path on the bridge over the Saint Lawrence River and convincing the transit officials to allow bicycles in the rear cars of the subway trains. They have approached these concerns with petitions, letter-writing, and a survey which found the majority of rear and subway cars to be empty during non-rush hours. They have also employed creative environmentalism in a bicycle "motorcade" at rush hour in which each cycle was fitted with a plywood frame, the size of a large automobile, to dramatize the minimal space requirements of commuters on bicycles as opposed to private cars. They also gained attention for their "campaign of ridicule" in which the bicyclists descended on the subway cars by foot carrying a clumsy array of implements: ladders, a mattress, a bicycle, and a stuffed hippopotamus. Only the bicycle was legally barred from the train.

Reference: Environmental Action, July/August 1981, "Vive la velorution," by Peter Harnik, pp. 28-30.

TRANSPORTATION UNIT: The Projects

AUXILIARY MATERIALS

1. FDR High School Transportation Survey
2. Martin Luther King Jr. High School Westway Survey

Survey on Transportation in the Neighborhood

The students, based on their own experiences recorded in their journals, designed the survey for neighborhood residents. Following are the questions residents were asked by the students.

Introduction: Good morning. I'm a student from FDR High School. We're out here today to take a survey of community residents. We want to know what you think about the transportation system in this community. This information will be presented in a report to the MTA and to the local community board. Can you help us out by asking a few questions?

1. Do you use the public transportation system? Why or why not?
(If not, ask what form of transportation they use, and go to questions 2, 5, 6, 9, and 10)
2. Do you feel your neighborhood is well-served by the public transportation system? Why or why not?
3. What forms of public transportation do you use? Which lines? At what time of day? How often do you use the system?
4. Is this form of transportation hard to get to from your home?
5. Do you think transportation creates pollution in your community? How could this problem be solved?
6. What major problems have you had with the transportation system? Have you ever been late because of it?
7. What do you think about the fare charged by the public transportation system?
8. Has the noise created by the transit system ever bothered you in your home.
9. Do you think using other forms of transportation, such as bicycles, walking, or cars, would help your community? Would you ride a bicycle to help your community?
10. I know this is a sensitive question, but do you feel safe using the public transportation system? Have you ever been the victim of a crime on the transit system?
11. If you have ever seen the rules being broken, how do you feel about this? Are there enough police on the system? How do you feel about the Guardian Angels?
12. What are the best aspects of the public transportation system? The worst?
13. If you were in charge of the MTA for one day, what changes would you make, especially in this neighborhood?

SURVEY ON WESTWAY

- 1) Age (Check off) under 18 _____
 18-25 _____
 26-35 _____
 36-45 _____
 46-65 _____
 65+ _____
- 2) Have you heard of Westway?
- 3) What borough do you live in?
- 4) What form of transportation do you take most often in the city?
- 5) Do you support or oppose the Westway project? Why or why not?
- 6) What impact would Westway have on the city?
- 7) What impact would Westway have on you personally?
- 8) Should the Westway funds be traded-in to improve mass transit?
Why or why not?
- 9) In your opinion, will the construction of Westway increase or decrease jobs in the city?

10) What is your opinion on the housing which will be built on the Westway landfill?

11) Is it more important to build Westway park, or to fix existing parks in the city?

12) Do you feel that Westway's overall impact on the New York City environment will be positive or negative?

ALSO, ASK THE PERSON IF HE OR SHE WOULD LIKE A FACT SHEET.

REFERENCES

Regional Transportation Status 1988, John G. Allen,
New York Metropolitan Transportation Council,
July 1989.

Strategic Business Plan 1990-1994, Vol.1 Major Issues
and Strategies and Vol.2 Appendix, Metropolitan
Transportation Authority, June 1989.

Strategic Planning Initiative 1988, Metropolitan
Transportation Authority.



TRAINING STUDENT ORGANIZERS

CURRICULUM

PART II

P r o c e s s



Introduction

In Part I we have presented information, lesson plans, etc. on issues studied and projects organized by students and teachers in CENYC's Training Student Organizers (TSO) Program over the past eleven years. We have given specific lesson-by-lesson layouts or narratives of the projects. The project sections in Part I can basically be used on their own by teachers, youth leaders, neighborhood leaders, etc. to guide students, youth groups, community groups to organize environmental improvement projects.

Part II consists of a series of stages and steps for introducing, determining, and coordinating an environmental improvement or other neighborhood project. Part II is meant to enrich and guide the project layouts in Part I. Specific tasks such as writing a press release or flyer are dealt with in detail in Part II. Where such activities are called for in Part I, teacher /group leaders/neighborhood organizers can refer to appropriate pages in Part II.

Part II deals with environmental and social action project organizing when the teacher, group leader, neighborhood organizer, etc. has the time, resources, and group to involve the community in a very complete sense. We realize this may not be the case, particularly with teachers trying to organize a project with classes of varying performance levels on a tight school schedule. However, the process is presented as an "ideal" one, not necessarily one to be emulated in every detail.

Even in cases where comprehensive community involvement is feasible, we have found that particularly when working with students, it is important to be vigilant concerning the possibility of too much "pull" or "tension" from community groups, political officials, etc. Our staff, the students, and the schools work cooperatively with community officials and organizations in conducting needs assessment, project selection and implementation. We've been reluctant in recent years, however, to establish formal community organizations to support student efforts. The quest to control community organizations and student projects can lead community officials and active residents to ignore the needs of the youth they are working with, and to consider them as mere accessories to particular goals of the community organization. Hence, we've attempted to establish consistent but informal project-by-project relationships with local public and community agencies.

This is not to say that close work with the community should not be pursued and that formal student/community organizations

shouldn't be established. Such organizations require time and attention, though.

In addition to the project organizing process laid out in Part II, we often use a simple outline in the classroom to pull together many of the processes inherent in project organizing, which are discussed at length in the curriculum.

Issue ----->Project

Strategy Tactic/Method

In other words, we discuss with the students the environmental issue they want to highlight, and then help them to make decisions on the overall strategy for the project, and the tactics or methods through which they will implement the strategy. Two specific project examples follow.

(1) Issue/Subway Noise ----->Project

Strategy* Tactic/Method

Politi-
cal/Legis-
lative
Action

Letter writing and
petitioning campaigns;
motivating other students
and community residents
to write political
officials to monitor and
enforce existing subway
noise reduction codes

Education

Noise Awareness Day on
commercial street under
elevated train structure;
distribution of informa-
tion sheets and ear plugs
at table

(2) Issue/Beautification ----->Project
Graffiti/Public Art

*We generally classify strategies as Education, Service, Political and Legislative Action, and Direct Action. Some projects use a combination of different strategies, and some tactics relate to more than one strategy.

Strategy

Tactic/Method

Service and
Direct
Action

Organize a participatory mural on a large wall on campus to cover graffiti. Encourage participation of legitimate artists who use graffiti style art in their work

Of course, using this more concise model doesn't mean you can short-circuit the needs assessment, issue/project selection and planning, issue examination, and field organizing steps covered in this part of the curriculum. However, the model does help crystallize many of the steps involved in project organizing. The model is used in several projects in Part I.

UNIT A: THE RATIONALE FOR CITIZEN PARTICIPATION

Lesson #1

Aim: To learn why citizen participation is important.

Motivation/Discussion:

The benefits of citizen participation:

- a. Political. Do people have more power as part of a community?
- b. Social and Cultural. Do people relate better to each other and have a deeper sense of community pride?
- c. Economic. Are community resources used more efficiently and equitably?
- d. Personal. Do people tend to feel more responsible for and better about themselves and their community?

Followup:

See "A Democratic Awakening" by Harry Boyte in Social Policy, September/October 1979, Vol. 10, No. 2, 33 W. 42nd St., New York 10036

Lesson #2

Aim: To analyze local citizen participation.

Motivation: Each student should ask five people of voting age whether they voted in the last mayoral or equivalent election and the last school board election. Also ask the same five persons how many school board meetings they attended in the last

year and whether they belong to any community organization, e.g., block association, community garden, homeowners association, etc. Have each student record the results and pool the class findings.

Discussion:

a. From this small informal survey and from your own experience, do you think most people tend to participate in local elections, community organizations, etc.?

b. Do you think participation is encouraged in the community, city, and nation?

c. To really answer these questions, do a more formal analysis of participation patterns. Analyze the percentage of people of voting age (registered and non-registered) from the neighborhood who voted in the last mayoral election and in the last school board elections. The Board of Elections should have these statistics for each election district.

d. Try to get statistics on the number of block or community associations in the neighborhood, borough, and city, as well as the number of active members in each group. The local Planning Commission, Bureau of Statistics, or Chamber of Commerce may have such figures. The class should be divided into groups to do the necessary research.

Time Frame: 2 to 3 weeks

e. When the data has been collected, the students should make a chart:

% Eligible Voters Voting In:

	Last Mayoral Election	Last School Board Election	% Blocks or com- munities organized	% Active Members in Block or Com- munity Associa- tions
--	-----------------------------	-------------------------------------	--	---

Neighbor-
hood/Com-
munity

Town or
City

f. What do the statistics show about participation patterns in these categories?

g. Was it easy to find statistics, particularly on the block or community level? If you weren't able to find accurate statistics on this item, what might that indicate?

Followup:

* Ask students interested in further statistical analysis to do similar research concerning participation in other elections, community organizations, public hearings, etc. Many kinds of data, e.g., census tracts, can be employed.

* A particularly interesting although difficult analysis could be a comparison of various participation tendencies in different countries. Data could be difficult to obtain and standards of comparison hard to develop but the results of such a study could be quite illuminating with respect to our society.

Lesson #3

Aim: To discuss the benefits of citizen participation in environmental improvement projects.

Motivation:

Do you remember what percentage of the world's annual energy use is consumed by the United States which has less than 5% of the world's population? (See Introduction to Energy Unit in Part I.) Can anyone explain the "Greenhouse Effect?" (See page 108 in Part I.)

Discussion:

a. From our readings and discussions, can we make any general statements about the condition of the environment in the U.S. and/or the world at this time?

b. Are air and water pollution, energy waste, housing deterioration, the "Greenhouse Effect," the "garbage time bomb," etc., problems that citizens have to deal with? (Students will probably have studied some lessons from Part I already.)

c. Are environmental issues significant enough to warrant citizen action to effect change?

d. Do you think there is a great deal of citizen participation in important environmental issues at this time?

Followup:

Have the class read the most recent State of the World by the Worldwatch Institute, 1776 Massachusetts Ave, NW, Washington DC 20036.

Lesson #4

Aim: To explore organizing as an appropriate and effective means of motivating ongoing participation.

Motivation: Have students read case studies on organizing from Alinsky's Reveille for Radicals¹⁵, pp. 101-131, 159-189.

Discussion:

- a. Would situations change for the better if people didn't organize themselves for change?
- b. Why might a citizen group organized around a particular issue be effective in causing positive change?
- c. Do you think organizing citizens to participate in environmental activities in the community is necessary? Can it be effective? What environmental issues do you feel are most important?

UNIT B: NEEDS ASSESSMENT AND PROJECT SELECTION

Lesson #1

Aim: To learn to assess the needs and problems of our community.¹⁶

Motivation/Discussion:

- a. What methods can you think of to use to find out the environmental problems in the community?
- b. Make a list of methods:

* Student observations

¹⁵ This title and that of Alinsky's other major work, Rules for Radicals, shouldn't intimidate anyone. What was "radical" in a tactical sense when these books were written is now standard fare for many neighborhood organizations and certainly familiar to those involved in all social change movements in the U.S.

¹⁶ Community has not been defined very specifically in any of the lessons. It's up to the organizer, supervisors, and group to specify the boundaries which demarcate "community."

- * Informal discussion and interviews with friends, community residents, storeowners, etc.

- * Formal interviews with storeowners, community board members, leaders of civic groups

- * Formal questionnaire distributed through random sampling of the community

- * Analysis of census data, planning board fact sheets and guide books

- * Formal, extensive community survey

- * Sociological techniques like behavioral mapping to assess current uses of a particular space

c. What factors should be considered in choosing a method of assessment?

- * Time required for project development

- * Instruments available to organizing group

- * Size of organizing class and experience in doing such work

- * Surveys and studies that have already been done

d. Select an assessment strategy with the group. If time, group size, and assessment experience are problems, try to use already existing formal studies of area problems.

* The observations of the group, teachers, and administrators in the school, members of key community groups, can complement any surveys or statistics that are at the group's disposal.

Followup:

* Do a role-play interview with some members of the class to demonstrate an organizer/interviewer trying to question a storeowner or school board member on the key environmental problems in the community.

Lesson #2

Aim: To consider other necessary factors in choosing a project to be organized.

Motivation: From the analysis so far, make a list of major environmental problems facing the community.

Discussion:

a. The items on the list might be:

- * Litter on the street and in parks

- * Inadequate transportation

- * Garbage disposal

- * Park deterioration
- * Noise
- * Traffic congestion and safety
- * Need for beautification of public spaces
- * Price of oil and gas; need for energy conservation
- * Water quality
- * Air quality

b. What group or groups would be best to involve in projects related to these problems?

- * Senior citizens
- * School children
- * Other youth groups, e.g., scouts
- * Storeowners
- * Tenants
- * Trade associations, merchants' associations
- * Churches
- * Parent organizations
- * Etc.

c. Where should we start organizing the project; i.e., what should be our initial base?

- * A school
- * A community group
- * A service facility, e.g., hospital
- * A combination of groups

d. In what particular geographic area of our community should we start our project?

e. In considering the potential project idea, groups to be involved, area and base to organize in, what other factors should we consider?

- * What kind of outreach potential in terms of quantity and quality of participation does each problem area, group, location, organizing base offer?
- * What is the potential for a lasting project?
- * What is the funding potential?
- * What are the time limitations for each set of possibilities in terms of securing cooperation and permission of local authorities and actually carrying out the project?
- * What kind of immediate and long term environmental effect will the project have? Will the general environmental issue the project relates to be emphasized?
- * What will the educational value of the project be to both student organizers and the community?

f. In pooling all these factors, information from the assessment should be considered essential.

g. Ask the class to suggest specific projects which combine the factors discussed. For example:

- * An anti-litter campaign on a major thoroughfare involving students of all ages, storeowners, senior citizens, etc.
- * A beautification program to involve all citizens in a new design for a local park.
- * An energy conservation program for homeowners.
- * A tree-planting and horticultural program for neighborhood residents in a local park.
- * An aluminum recycling program in a local high school and its feeder elementary and junior high school.
- * See other possible projects in each unit of Part I.

Followup:

Ask the class to contact some key community groups, schools, etc. and get feedback on the project(s) the organizing group is considering.

Lesson #3

Aim: To decide on a project.¹⁷

Motivation/Discussion:

The organizing class and the community support groups should come to a decision on one or more projects to organize from the ideas being considered. In making the decision, data from the assessment should be brought into the discussion whenever possible. All factors mentioned previously should be considered.

The time frame is important. You can either choose a project that can be accomplished in one semester or one that will take longer if you are reasonably confident that other students will be agreeable to carrying on where former students left off.

¹⁷ Each class or group will be working on its own particular project. However, for simplicity's sake, most of the specific project references in the following lessons refer to the Kings Highway Anti-Litter campaign organized by Brooklyn College and Madison High School students in New York City between 1979 and 1982. Some of the other references or materials stem from additional projects developed in CENYC's Training Student Organizers (TSO) Program between 1979 and 1989.

UNIT C: PROJECT PLANNING AND INITIAL FIELD ORGANIZING

Lesson #1

Aim: To determine what resources are needed to begin the project.

Motivation/Discussion:

a. What is the capacity of the groups we want to include in the project -- school, senior citizens, community groups, etc.-- to obtain or reproduce needed materials? If not through target groups, how can we obtain these materials?

b. What initial participation strategies (e.g., workshops, events, meetings, block parties, etc.) are we considering and what resources are needed?

- * Mailing lists
- * Slides
- * Posters
- * Flyers
- * Newspapers and radio advertising
- * Books, articles, other data for workshops

c. Prepare a general project strategy/resource chart for dates, resources, participation goals.

SAMPLE

Anti-Litter Campaign Project Strategy

PROJECT STRATEGY/RESOURCE CHART

GOALS	METHODS	RESOURCES	WHERE AND HOW OBTAINED	TIMING
<u>General:</u> Clean up Kings Hwy	<u>General:</u> Involve all citizens in the area in the cleanup campaign	Brooms and shovels	Sanitation Dept. loan	<u>First 6 months of project:</u> Goals 1 and 2 Method 1
		Bags	Fast Food Chain donation	

GOALS	METHODS	RESOURCES	WHERE AND HOW OBTAINED	TIMING
<u>Specific:</u>	<u>Specific:</u>	Flyers	Prepared in-house	
1. Conduct monthly, then weekly sweeps 2. Place garbage cans along the highway 3. Prevent litter through other forms of citizen participation	1a. Organize students, youth groups, senior citizens, store-owners to conduct sweeps			<u>Next 12 months of project</u> Goal 3 Method 2
	b. Involve tenants and other citizens in the sweeps	Posters	College/-high school art depts.	
	c. Evolve a citizen rotational system for doing monthly, then weekly sweeps	Garbage cans	Needs fund-raising campaign	
	d. Motivate business and store-owners to "adopt-a-can"	Pamphlets	Local environmental organization	
	2a. Develop a citizen "litter watch"	Speakers for workshops	Local environmental or civic organizations	
	b. Give workshops to storeowners	Mailing lists	Local planning and community organizations	

d. As the project unfolds, such a general chart can be made much more specific and quantitative with numerical goals for participation and more specific dates.

e. If more than one project is being organized, the class can be divided into the appropriate number of organizing groups. It is not advisable with a beginning group to attempt more than one project.

Followup:

* Start to think about and discuss dividing the organizing group for the project into subcommittees to begin carrying out the needed tasks. A possible division of functions would be:

- ▶ Publicity and graphics
- ▶ Fundraising
- ▶ Administrative coordination and evaluation (includes statistical and photographic documentation)
- ▶ Organizing inside the school
- ▶ Field organizing

* Ask the students to think about which subcommittees they would like to be on. Give a general description of what each might deal with. (More specifics will be discussed as the next activities begin.)

* Have the students think about whether a specific "tactic" is necessary to motivate people to participate in the initial strategy, or to gain attention for it, e.g., piling litter high on a street corner to draw attention to the litter issue and gain attention for a sweep, or handing out earplugs to citizens in a noisy section of town to highlight noise problems. Such tactics may or may not be essential in this kind of project organizing, depending on the nature of the community, the project, etc.

* Keep in mind that many of the organizing functions overlap and can be performed by any of 2 or 3 sub-groups.

* If college students are supervising high school organizers, each college organizer-supervisor should be assigned a group to coordinate.

Lesson #2

Aim: To begin field organizing.

Motivation: Students attend a local planning board or department meeting.

Discussion/Experience:

a. The administrative committee should compile a list of key people on local planning board, school board, business organizations, etc.

* Using such information students on the field organizing committee should make further contacts with the local planning board, school board, etc., and the appropriate committees to ascertain whether additional approval for the project is necessary.

* Also, the field organizing committee should make local political figures, merchant groups, block or community associations, etc. aware that project organizing is beginning and ask for their help.

* Preparation for the initial participation strategies discussed should begin.

For example: The publicity group should inquire about obtaining press lists and the possibility of having posters made by the school art departments. Local businesses might be willing to pay printing costs and/or services.

b. If the primary initial participation strategy, e.g., workshop or block party, hasn't been solidified from previous discussions, then determine one or two key activities.

Followup:

Ask the students if they are satisfied with their sub-committee assignments, if the functions of each group are appropriate, and what changes are needed.

Lesson #3A

Aim: To train students in the preparation of a press release.

Motivation: Short talk to the whole class by a publicity specialist from a local business, government or non-profit agency on the preparation of a press release.

Discussion/Experience:

a. Ask the class to prepare a short (one paragraph) introduction explaining the project and the initial strategy, e.g., a sweep-up.

b. Have some of the students read their paragraph to the class for critical analysis.

c. Stress the importance of explaining the purpose of the program, the date, time, place and initial activity in the first one or two sentences (see Note on Press Releases on p. 202 and see model releases on pp. 203-204).

d. Explain that while a press release is primarily for newspapers, radio and television stations, it can be used as an introductory notice to any interested party.

e. Ask the publicity committee to use the discussion and paragraphs written by fellow students to prepare a release.

f. Ask the publicity committee to put together a list of key newspapers, radio stations, and local organizations that send mailings to local residents, etc. Local planning boards, civic organizations (churches, schools) often do mailings and have lists. The group will have to determine whether local, citywide or even wider audience media or other target groups should be included. Usually for smaller press, a release should be sent three weeks ahead of the event; about two weeks is adequate for larger press. The time schedules relate to getting the paper or station to publicize the event prior to its occurrence. To get coverage on the day of the activity or after will require a release a few days before and a followup call the day before. In addition to the release, an editor's advisory (short description of the upcoming event) is sometimes sent as well.

g. A followup phone call, after release has been sent, urging a reporter to attend the event and offering to meet with her or him and sending additional materials is an important part of effective publicity. Be brief and interesting on the phone and in your letters.

Lesson #3B:

Aim: To train students in the preparation of a flyer.

Discussion/Experience:

Go through similar steps as in mini-lesson 3A (see model flyer and comments attached on pp. 205-208) and then assign the preparation of a flyer to the committee.

Followup:

Show both the release and the flyer to the whole class for critical analysis.

Lesson #4

Aim: To develop an outreach model for motivating participation in the project's initial strategy.

Motivation: Make copies and distribute the outreach model on pp. 210-11.

Discussion/Experience:

a. Ask the students if they think the model is comprehensive, i.e., does it target the groups and specific contacts they want to involve in the event?

. Ask the class to adapt this model to their current strategy and goals.

- * What groups do we want to involve in the initial participation strategy?

- * What specific contacts should we telephone and/or mail press release and/or flyers to?

- * Ask the class to suggest expansions of the model.

- * Quantify the model by estimating the numbers of people who will participate from each contact and group.

- * Discuss the optimum number for participation in the initial strategy given the group's resources.

- * Refer to the Project Strategy/Resource Chart and update it by quantifying specific participation goals and the resources needed.

- * Discuss the development of an initial participation strategy with respect to the quality of the experience, i.e., what is the appropriate number of people to make a workshop or event effective, as well as meaningful and enjoyable to the participants?

b. Divide responsibility for making contacts and follow-ups between the in-school and field organizing committees.

c. Develop a timetable as to when contacts should be made.

d. Discuss with each committee and individual student their assignments and begin implementation of the strategy.

Followup:

- * Conduct role playing sessions for phone calls and field contacts with student organizers.

- * Conduct demonstration field trips to make personal contacts.

- * Involve student organizers from other committees besides the in-school and field organizing ones in role-playing and field demonstration activities.

- * All students will have to be involved in certain field experiences for manpower reasons e.g., posting flyers in the community, or preparing a mass mailing to media (local and/or citywide) and local organizations (schools, block associations, merchant associations, banks, etc.).

- * If a mail strategy is employed (in many small area projects the phone and field approach is more direct and less expensive) conduct a separate session on the rationale for the strategy, the numbers to be reached, the anticipated response. The administrative committee should try to acquire and keep on file the necessary mailing lists and names of organizations who would insert the press release or flyer in their own mailings.

* There will be a need for frequent evaluation of the contact strategies, the effectiveness of the outreach model, and the personal interaction that organizers have with the people they are contacting.

Lesson #5A

Aim: To train students in beginning fundraising techniques.

Motivation: Refer to the Strategy/Resource Chart and identify the areas where funding is needed. (Some materials could be obtained directly from local organizations.)

Discussion/Experience:

a. After analyzing the chart, figure with the class the amount of money and resources needed for the project as a whole and the initial participation strategy in particular.

b. Develop a strategy to secure funding for the immediate participation activities. The administrative coordination committee can try to obtain free materials and literature. The fundraising committee can organize a cake sale, dance, etc. to get immediate funds. Other strategies could include a field trip to ask merchants to contribute to the project or setting up a booth at a local street fair with proceeds to go to the project.

* Fundraising strategies should be discussed with the whole class as well as with the members of the administrative committee.

* Specific dates should be attached to the various activities and goals set for amounts of money and materials needed.

* Determine with the entire class the long range funding needs and which fundraising activities have to begin immediately, e.g., applying for a booth at a fair to occur three months in the future.

* The fundraising committee should research the upcoming fairs and events for money-raising potential and develop specific target activities to plan for and to match the financial goals the class has established.

Lesson #5B

Aim: To train students in the preparation of a fundraising letter.

Motivation/Discussion:

a. A fundraising letter is a key long-range strategy. A good letter with appropriate accompanying materials sent to appropriate organizations, in and out of the community, can raise significant amounts of money, particularly if followed up with phone calls and meetings.

* Have the fundraising committee prepare a letter (see model letters and comments on pp. 212-215).

* As a training experience, have the whole class analyze the letter. The fundraising committee should prepare the final draft.

b. Have the fundraising committee target the organizations to be sent the letter after doing an analysis of local banks, corporations, small businesses, etc., that might help. Such an analysis should begin with the immediate community whose organizations are most likely to help and branch out from there to sources outside the area.

SAMPLE MATERIALS WITH EXPLANATORY COMMENTS
FOR PROJECT MATERIALS REFERRED TO IN UNIT C

A Note on Press Releases

Factors to Consider

1. Length Most organizers, publicity specialists, etc., will opt for brevity but not at all costs. The first release (all releases written by students) shown here covers all information and provides enough detail for a newspaper to form an article around it or reprint it in its entirety. Certainly this release would be appropriate for reporters on the day of the event when they are on the scene; the second and shorter release would be better to catch the attention of a news desk so that a reporter may be assigned to the event.

2. Specific Information Whatever the total length, it is important that the release attract attention in the first paragraph by giving a direct, concise explanation of the main aspects of the event or project in question along with key information as to WHAT, WHERE, WHEN (date, time, description of event, exact location). The first paragraph should be a maximum of two-three sentences.

The information will allow a news desk at a newspaper, or radio or television station to quickly know whether the item is significant to them and whether coverage is possible. It also makes their job easier and allows them to more efficiently handle the large amount of news items that come across their desks. Such immediate information may motivate the recipient to read on.

3. Simplicity and Clarity An essential point. A news desk will not respond to press releases that are wordy.

Essentials for a Press Release

1. First paragraph must give details on WHAT, WHERE, WHEN.
2. Short sentences and paragraphs.
3. Name of contact person and how to contact her/him must be clearly in evidence.
4. Release date must be mentioned on top of the page, e.g., "For Release July 9, 1985" or "FOR IMMEDIATE RELEASE."
5. A press release must be double spaced for easy reading and editing.

Council on the Environment of New York City
51 Chambers Street, Room 228
New York, N.Y. 10007 (212) 566 0990

Marian S. Heiskell, Chairman. Lys McLaughlin, Executive Director.

FOR IMMEDIATE RELEASE

For further information:

November 7, 1988

Dennis Bader (212) 566-0990

Joyce Rosenthal "

MARINE POLLUTION SYMPOSIUM IN BROOKLYN

On December 1 at 6:30 p.m., students from Franklin Delano Roosevelt (FDR) High School and Beach Channel High School will host a symposium about litter and pollution in the marine environment at Kingsborough Community College in Brooklyn.

Discussions by students, government officials and community residents on the role that citizens can play as stewards of marine resources will follow presentations by water resource experts from the New Jersey Department of Environmental Protection and the New York State Department of Environmental Conservation and others.

Marine floatables, including styrofoam and plastic garbage, have severely impacted our coastal areas and water quality. Every year, marine creatures die from ingesting plastic pellets used for packaging and shipping. Migrating sea turtles perish by consuming plastic bags, which they mistake as food. Water fowl are killed or injured by entanglement in unattended or discarded fishing line and nets haphazardly cast into open ocean and wetland areas.

An honors Economics class from FDR in Brooklyn and a Marine Biology class from Beach Channel High School in Queens studied the impact of marine floatables and water pollution on our beaches and in our tidal salt marshes, estuaries, bays, harbors and oceans for nine weeks with the Council on the Environment of New York City's Training Student Organizers Program (TSO). They organized the Marine Floatables Symposium as part of their work with TSO, which trains high school and college students to organize environmental improvement projects in their schools and communities.

The Council on the Environment of New York City is a privately funded citizens organization in the Office of the Mayor dedicated to improving New York City's environment. In addition to TSO, CENYC operates the Office Paper Recycling Service; Greenmarket, a series of farmers markets; and the Open Space Greening Program.

* * * * *

THE PRESS IS INVITED TO ATTEND THE SYMPOSIUM AT KINGSBOROUGH COMMUNITY COLLEGE, 2001 ORIENTAL BLVD., BROOKLYN, NY., AT 6:30 P.M. ON DECEMBER 1ST IN THE SCIENCE LECTURE HALL, ROOM S162. FURTHER INFORMATION UPON REQUEST.

NEWS From



Council on the Environment of New York City

51 Chambers St., Rm. 228

New York, N. Y. 10007----566-0990

Marian S. Heiskell, Chairman

Lys McLaughlin, Executive Director

For Release: IMMEDIATELY

Date: October 18, 1985

**Contact: Carolyn Steiner 566-0990
Eileen McGurty 566-0990**

FDR STUDENTS ORGANIZE CLEAN-UP

Over 100 FDR High School students and Borough Park neighborhood residents will conduct a street clean-up on November 12, 1985 from 10:15-11:45 AM. The students and residents will sweep 20th Avenue from the front of FDR High School at 59th Street to 52nd Street.

The event is sponsored by FDR High School Social Studies Department and the Council on the Environment of New York City (CENYC).

Two American History classes are responsible for organizing the event. These students were trained in environmental project organizing by CENYC's Training Student Organizers Program.

The Council on the Environment of New York City is a privately funded citizens' organization in the Office of the Mayor dedicated to improving New York's environment. CENYC also operates an Office Paper Recycling Service, an Open Space Greening Program, and Greenmarket, a series of farmers' markets.

Directions to FDR By Car: McDonald Ave to 20th Ave.
South on 20th Ave to FDR
High School.

By Subway: F train to Avenue I
station. Walk south on
20th Avenue to FDR High
School

FLYERS

With Notes on Posters, Leaflets, and Introduction Notices

Factors to Consider

1. Getting Attention A flyer must have an overall design that draws the recipient to it. The flyers shown on pages 207 and 208 designed by college and high school students, are reasonably good. The graphics are attractive and fairly simple and there is some word or picture in each that serves as a focal point.

2. Information The flyer should give key information concerning the event: date, time, place, raindate, requirements for participation, etc. Identification of all principal sponsors should be highlighted and the name of the project obvious.

3. Clarity The two flyers shown here are good examples of the virtues of being visually clear. Flyer #1 has one large eye-grabber -- the event title -- and the rest of the information is in only two other sizes of print, in order of importance. That is, first the viewer's attention is drawn to the title, which also tells "WHAT;" then the viewer is told "WHERE" and "WHEN;" then the background information -- "WHY" and by "WHOM" is delivered. Flyer #2 is perhaps a little too wordy, but there is a central graphic item to focus on: the initial heading.

If the flyers are to be posted as well as handed out, they should be printed on a color of paper which stands out from the background: green, for example. Black letters are readable.

4. Size Usually flyers are 8-1/2" by 11" or 8-1/2" by 14" and can be posted, handed out, or sent through the mail. Larger flyers are best for posting.

5. Note on Posters Posters are usually two to five times the size of a flyer and are posted for relatively long periods of time. The same balance of information, clarity, and attractiveness has to be attained. Even if used in conjunction with flyers, leaflets and notices, posters must contain all basic information.

6. Note on Leaflets A one-page leaflet has more detailed information than a flyer and the leaflet may be folded so that the four sides contain more information than the flyer.

7. Note on Introduction Notices A separate introduction notice can be sent to schools, citizen groups, senior citizens to advertise and invite participation in the project. The notice would contain two or three paragraphs on the project and initial

participation strategy and possibly some small graphics as well. A tear-off slip could be added as a device to monitor initial interest and also as a record-keeping tool.

EARTH DAY SWEEP

Where:
Bedford Park
Blyd. and
Jerome Ave.

When:
April 22nd
2:30 pm - 6 pm



WE CORDIALLY INVITE YOU TO JOIN WITH US
IN THE CELEBRATION OF EARTH DAY 1980. ON
THIS SPECIAL OCCASION WE WILL HELP
BEAUTIFY OUR ENVIRONMENT BY UNDER-
TAKING A SWEEP ON BEDFORD PARK BLVD.

PLEASE COME AND LEND A HAND.
IF YOU CARE EVERYONE WILL!

SPONSORED BY:

LEHMAN COLLEGE ENVIRONMENTAL GROUP
UNITED ASSOCIATIONS OF BEDFORD PARK
COUNCIL ON THE ENVIRONMENT OF NYC.

COMMUNITY NOISE POLLUTION

NOISE IS HARMFUL TO YOUR HEALTH, LEARN HOW TO PROTECT YOURSELF!

Noise from cars, buses and subways can impair your hearing ability if you are exposed to them for lengthy periods of time. Unwanted noise from neighbors, construction, or trash collection during quiet hours can disturb your sleep, thought process, and cause irritability, anxiety and high blood pressure. These are just some of the characteristics of noise pollution and its consequences.

Come and find out about noise and what the laws are pertaining to community noise pollution problems.

Talk to police, government officials and private citizen concern groups. Representatives from the New York City Department of Environmental Protection, Flatbush Tenants Council, Council On the Environment of New York City, the New York City Department of Transportation and the "Big Screamers" will be present to answer your questions and listen to your concerns.

Where: James Madison High School Auditorium (corner of Bedford Avenue and Quentin Road, Bklyn.).

Time: 7:30 P.M.

Date: Tuesday, June 14th.

Sponsored by the James Madison High School mentor Law and Sociology class of 1988.

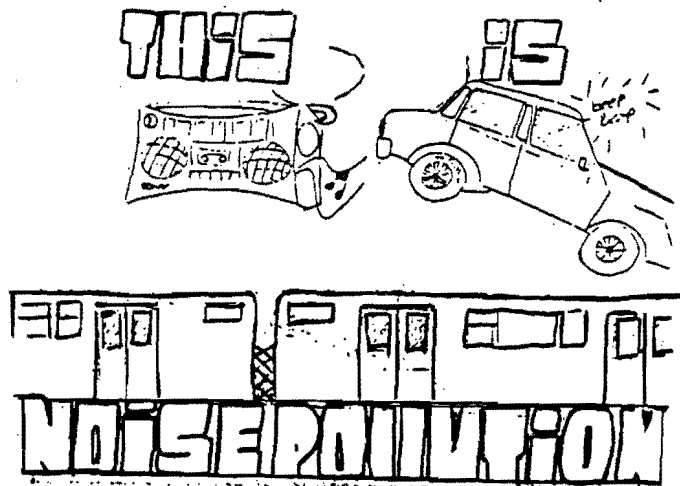

OUTREACH MODEL

A key part of the initial attempt to involve citizens in a project is the development of a formal process for securing participation in whatever initial strategy has been selected. Groups to be contacted, methods of contact (phone, mail, workshop), contact assignments for each organizer, etc. must be identified.

The outreach model included here was drawn by assignments for each organizer in a Brooklyn College-Madison High School project to organize a sweep-up as the initial participation strategy in an anti--litter campaign. The organizers are given assignments in two main target areas -- the students inside Madison High School and the community outside the school. The assignments inside Madison are speaking engagements with different clubs along with flyer dissemination and school newspaper publicity. The community assignments are also mainly speaking engagements with groups that have been identified as likely participants in the sweep-up on the day and date chosen. Distribution of flyers is also included together with a press release mailing and followup phone calls.

The outreach model could be organized in several different ways -- by assignment, by groups to be contacted, by locality, by contact method, etc. Also, the model should include some estimation of the number of persons who will participate from each method, group, etc. and a total estimate of participation. Then an accurate ordering of whatever materials are needed for the event can be made.

A more complete model could look like:

General Target Area	Groups to Contact and Contact Method	Organizers Assigned
A. <u>Inside School</u>	Sports Clubs Arts Clubs News Groups	
B. <u>Community</u>	Senior Citizens Storeowners Youth Clubs and Schools Media Political Contacts Press	

SAMPLE OUTREACH MODEL

Organizing Assignments: Sweep-up on Kings Highway

A. Inside Madison High School

Give teacher a flyer and arrange to give a short 2-5 minute talk to club or team (Richard P. runs off flyers).

-
1. Richard P. Glee club, band, orchestra, music club, art squad, girls' basketball, tennis

 2. Richard L. Softball, math, basketball, boosters, cheerleaders, twirlers

 3. Paula Boys' basketball, football teams, foreign language, encampment, law journal

 4. Donna Chess, volleyball, Fidelitas, Arista, Rocking Horse Five, bowling, golf, encampment

 5. David Student union, SAF, seekers

 6. Steve Science, theater arts, swimming club (boys and girls) wrestling, soccer

 7. Irv BOAC (school club)

 8. Debbie Track (cross country, indoor and outdoor, girls and boys)

 9. Mr. T. Third World Club

 10. Joel Will talk to Parents' Association for funding and participation

B. Outside Madison

Call on phone, give them flyers, speak to groups if possible.

-
1. Girl Scouts Paula

 2. Boy Scouts Joe M. and Steven

*In addition, a flyer should be put in each teacher's mailbox and should go up on all bulletin boards; the Madison High School newspapers should have news release (get from Joe, Joel or Mike); announcements should be made over loudspeakers on day of sweep. Mr. W. is a key coordinating figure in this.

3. Young Christians Joe M.

4. Senior Citizens Joel

- a. Kings Highway Center Elaine #627-7688, (Thurs. at 1), 250-300 seniors
 - b. East Midwood Jewish Center Sam, #377-3657, (every Wed.)
 - c. Greek Church, church office, #ES7-2002
-

5. Schools

- a. PS 197 Mike Z.
 - b. JHS 237 Marcel
-

6. Storeowners and larger businesses One field trip; give flyer; post it.

Storeowners Ask them to participate; posters should also go up; try to obtain funding for cans.

7. Media Send news releases to all stations and newspapers on lists that Marcel and Joel have. Use CENYC lists too?

8. Politicians Send letter and release to Mayor, Borough President, US Congressional representatives, State Assembly representatives, State Senator.

9. Posting flyers in neighborhood (everyone) OTB, banks, library, train station, bus station, supermarket.

10. Key Community Associations Send release and flyer; Mike Z. will send to seven of them.

FUNDRAISING LETTER

Factors to Consider:

1. Thoroughness -- A letter requesting funds must adequately explain the project in clear, concise terms, whether you explained the project to the person before or not.

2. Proper Length -- A one-two page letter including budget information and/or description of services/goods needed is appropriate at first. Then an accompanying project proposal plus complete budget and any other relevant material like support letters and publicity can be sent based on the requirements of the funding source.

3. Whether to Ask for a Specific Amount of Aid or Not -- A letter might describe the project broadly and let the potential contributor choose how much to give to whatever aspect of the program they wish to support, as in the first sample letter. A letter requesting specific items and including some background information is sometimes appropriate, as in the second example. However, the size of contribution is left open in these two letters.

Sometimes it is advisable to request a specific amount of money or materials, while in other instances it is advisable to give an organization a listing of possible financial or material contribution alternatives to choose from. The third sample letter does this.

4. The Obvious -- The letter MUST be correct grammatically, with no typos, and in a formal style that does not assume a contribution is forthcoming.

5. A Few Important Pointers

- a. Make your requests for funds or materials early on in the letter;
- b. Call the person written to two weeks after the letter is mailed to inquire if material is satisfactory, and if you can, come by and discuss the funding possibilities; and
- c. Offer to meet with the person you are writing to and to send additional material.

SAMPLE FUNDRAISING LETTER #1

ON ORGANIZATIONAL (SCHOOL
OR OTHER) LETTERHEAD

Name,
Title
Organization
Address

Date

Dear -----:

On Saturday, May 19th, James Madison High School will launch Project H.E.L.P. -- The Highway Environmental Litter Program. Madison students and other neighborhood youth, storeowners, senior citizens, etc. will sweep from East 16th Street to Coney Island Avenue.

I am writing today to ask for your help in this effort because Project H.E.L.P. needs financial and/or material contributions to make this effort a success. Funding is needed for garbage cans, bags, printed materials, mailings, etc.

The Saturday sweep-up will be the first of several along the Highway. H.E.L.P. hopes to have more garbage cans placed on the Highway at some time in the near future and have them serviced more frequently by the Sanitation Dept. Community workshops, recycling teams, etc. will be a part of this ongoing program which is being coordinated by Madison High School and Brooklyn College student environmental organizers.

We would deeply appreciate if you would consider making a contribution to our program. Such a gift would provide lasting support to our community since it would help build a financial base for an ongoing community participation-cleanup program which would involve citizens from all age levels and segments of our neighborhood. Thus, not only a clean Highway but also positive democratic values, greater understanding between groups, less crime, etc. would hopefully be the results.

We would be glad to meet with you at your convenience to discuss our request and to provide any further information required. Thank you so much for your attention.

Sincerely,

(Leave room for signature)

Name of School or Organization Representative
Name of School or Organization

ON ORGANIZATIONAL (SCHOOL
OR OTHER) LETTERHEAD

Name

Title

Date

(Local OTB office and representative)

Address

Dear -----:

On Saturday, June 16th, James Madison High School will launch Project H.E.L.P. — The Highway Environmental Litter Program. Madison students and other neighborhood youth, storeowners, senior citizens, etc. will sweep from Ocean Avenue to Ocean Parkway along Kings Highway in Brooklyn. OTB can be of real assistance by contributing some garbage cans to this effort.

The Saturday sweep-up will be the first of several along the Highway. H.E.L.P. hopes to have garbage cans placed on the Highway and have them serviced frequently by the Sanitation Department. Community workshops, recycling teams, etc. will be part of this ongoing program which is being coordinated by Madison High School student environmental organizers.

We feel that the placement of these cans along the Highway will be a key element in the success of the Kings Highway anti-litter program. Both formal studies and discussions with community residents and storeowners indicate that the availability of the cans will prevent much of the street litter that occurs. The Madison student organizers have organized a petition drive to secure the agreement of the citizens in the area to have garbage cans put back on the Highway and to have them serviced regularly by the Sanitation Department.

The program is part of a special course in the urban environment taught at Madison High School with support from Brooklyn College and its Office of Neighborhood Affairs, the Council on the Environment of New York City, and a number of other community groups. Madison students are being trained in the skills of coordinating environmental projects: planning, publicity, mail and workshop techniques, evaluation, record-keeping, developing and maintaining citizen participation, etc. The course syllabus will include readings on various urban environmental topics, e.g., solid waste, citizen participation theory and practice, and community development.

We would deeply appreciate if OTB would consider contributing some garbage cans, or the funds necessary to purchase them, to Project H.E.L.P. The cans best suited to our area cost \$15 each, and therefore some help is needed in order to obtain the twenty that we need. Such a contribution would provide essential material support to our ongoing community cleanup program.

We would be glad to meet with you at your convenience to discuss our requests and to provide any further information required. Thank you.

Sincerely,

(Leave room for signature)

Name of School or Organization Rep.

BOARD OF EDUCATION OF THE CITY OF NEW YORK
DEWITT CLINTON HIGH SCHOOL
100 WEST MOSHOLU PARKWAY SOUTH . BRONX, N.Y. 10468

SAMPLE
FUNDRAISING
LETTER #3

DAVID W. FUCHS
Principal

Telephone
543-1000

March 23, 1984

Susan Avent
Manager
Tremont Federal Savings and Loan Ass'n.
3445 Jerome Ave.
Bronx, New York 10467

Dear Ms. Avent,

We are a group of students from DeWitt Clinton High School. We are a ninth grade science class concerned with the beautification of our school and neighborhood.

We are planning a tree planting and labeling project to beautify the area around the school. In order to successfully carry out this project we need tree labels, a sapling for planting purposes, and related supplies. We estimate the total cost of this project to be \$125.00.

We know that the Bank has been supportive of another project at Clinton (\$25 for last year's successful anti-graffiti painting) and we hope you can help us again. Any financial contribution will be greatly appreciated.

Thank you very much.

Sincerely,

DeWitt Clinton General
Science Students for
a Better Environment

P.S. Please make any checks out to DeWitt Clinton High School and send to Mr. David Cohen at the school. For any further information please call Michael Zamm at the Council on the Environment of New York City at 566-0990.

FIELD INTERVIEWS

Organizing the project can require varied kinds of personal contacts with all types of individuals and groups. Talking with storeowners, senior citizens, public officials, community board members, etc. may be a regular part of the student organizer's work depending on the type of project. Some factors to consider are:

1. Informal, spontaneous contacts to get a person's opinion or suggestions concerning an issue or event are appropriate in some settings, e.g., interactions with storeowners. These informal contacts can be used to elicit participation in, or contribution to, a project, etc. This can be developed as long as the person's work is not interfered with: field interviews should not be undertaken during busy times of the day. Questions should be direct, brief, specific, and few in number. Several contacts should be planned for one time period so that organizing time is used efficiently, e.g., a field trip to ask storeowners for contributions to an anti-litter campaign. Key phone number, addresses, etc. should be noted. (See field trip sheet.)

2. Those who work in more formal settings, e.g., business offices, local public offices, agencies or community service settings, should be contacted by phone and a meeting arranged at a designated time. An introductory letter preceding the phone call might be useful in some circumstances.

3. The organizer should have preliminary questions in her/his mind before each interview. If necessary, a written set of notes can be used. Questions should be clear, specific, brief. The organizer should be direct with respect to any responsibilities s/he is asking the person to accept. Unless the situation is unusual, it is not advisable in the initial interviews to ask a person or organization to assume too much responsibility. As the discussion proceeds, notes should be taken if the organizer feels the person being interviewed is receptive. Both the organizer as well as the person or group being contacted should have a clear idea of the next step in the process before the interview ends, e.g., who will do what.

SAMPLE FIELD INTERVIEW SHEET

Storeowner Response

Area Covered:

Team Leader: _____

Student Organizer: _____

Date:

Secretary: _____

Check if on our response list	Name of store or business	Name of owner, Key person, etc.	Phone and Address	Nature of Response
-------------------------------------	------------------------------	------------------------------------	----------------------	-----------------------

(If necessary,
attach extra sheets.)

Special notes or recommendations:

Future strategies:

UNIT D: PROJECT MONITORING AND ONGOING PARTICIPATION STRATEGIES

Lesson #1

Aim: To build a base of participation among citizens who become involved in the initial strategy, e.g., sweep-up, workshop, etc.

Discussion:

a. What would be a good way to maintain contact with people who attend or participate in initial organizing events?

b. Discuss possible methods, e.g., asking people to put their names on a mailing list or passing sheets around with a space for people to outline the kinds of activities they would like to be involved in.

c. Analyze with the organizing class the possible strategies for involving people in subsequent activities. In the case of an anti-litter campaign:

- * More sweep-ups on a regular basis (monthly, weekly);
- * Meetings with active participants, community leaders, etc. to discuss setting up litter patrols;
- * Workshops or individual demonstrations in properly tying and bagging commercial refuse;
- * Community and business support in purchasing and servicing garbage cans.

d. Some form of mailing with a tear-sheet could be sent to all initial participants to ask their preferences for involvement.

e. Initial participants who are on the mailing list should also be informed of upcoming events and asked to return a tear-sheet indicating whether they plan to attend.

f. Statistics should be kept on the number of responses to particular meetings to ascertain which lists, groups and individuals are participation-oriented. (See evaluation unit on p. 225 for a more detailed description of participation analysis.) New goals for the quality and quantity of citizen participation should be established when necessary.

g. A special phone campaign with accompanying field visits should be made to contacts and organizations who represent key groups in terms of outreach to let them know about upcoming happenings, e.g., a second sweep, and to elicit their input into strategy development.

h. Community meetings to discuss the directions the campaign program might take will establish the beginnings of a citizen decision-making structure.

Followup:

Ideally, the goal of any organizing group is eventually to have the project coordinated and managed by the community it is serving; the organizing group, over time, has to try to establish ongoing structures in the community, e.g., a community leadership structure, divisions of responsibility, and organization.

Long-term structure of a program is complex and will involve the efforts of many people in addition to the organizing class. It usually is unrealistic for all but the most advanced and committed school or youth groups to attempt long-term organization building. The students should be made aware of this.

A long-term organization should, in addition to having a formal structure, involve as broad a spectrum of community residents as possible -- ethnic, economic, age, etc. The organization should also try to become a multi-issue organization, e.g., start with anti-litter and branch out to other environmental projects and issues, and possibly to other community concerns.

SPECIAL APPENDIX TO UNIT D

A. Note on Workshops and Group Presentations

1. Student organizers can be trained in giving a workshop or other presentation to a community group or to students in an elementary, junior high, or high school, especially if the presentation does not require that the speaker have a technical knowledge in an area, e.g., a presentation giving the overview of an anti-litter project. Organizers should first be given the opportunity to observe experienced workshop leaders in action. In those structures in which college students or graduate students are supervising high school students, the college organizers can be instructed initially and then help the high school students with their presentation techniques.

2. Key factors in giving a workshop or group presentation:

* Brevity and Clarity - The presentation should be short and to the point;

* Visual Materials - If possible, some visual materials should be used, e.g., slides, film-strips, posters, demonstrations to reinforce whatever points are being made and to keep workshop participants interested and motivated;

* Time for Questions - There should be time for questions and answers to get suggestions on project development, feedback on the workshop, and to encourage people to participate;

* Active Involvement - Whenever possible, workshop participants should be actively involved either through use of "hands on" materials or through discussions, role playing, etc.;

* Future Steps - The workshop participants should be left with some alternatives for action in the immediate period after the presentation. Notices might be handed out with a tear-off slip giving citizens the opportunity to sign up for a sweep-up or litter patrol or to communicate with the organizing group in the future.

B. Meetings

1. Depending on the project, organizers may have to attend meetings with groups e.g., representatives of the community board or council who might have influence over whether a particular project is allowed in a community, and with other groups. Meetings with community residents active in the project will always be needed. These meetings might be for planning purposes, to do actual material preparations, to develop strategies for participation or to analyze previous events. Organizers coordinating a meeting should take note of a few points:

* Agenda - For most situations, an agenda should be prepared which will give those who attend a meeting some structure for discussion. An agenda should be brief to center concentration on particular issues. If accompanying information is necessary, it should be included after the agenda page. See examples of two agendas of short and medium length.

* Minutes - A participant at the meeting should take minutes. The minutes should cover the essential items discussed at the meeting, and need not be a verbatim transcript. The minutes should be sent to all those at the meeting and all who were not able to attend but who are concerned. A book with all the minutes should be kept as a record of the interactions and as an information source for citizens, public officials, etc., who may become involved as the project and organization grows.

* Structure - It is advisable to develop a structure for meetings. Different members can serve in the various roles (chair, secretary, etc.) either on an elected term basis or simply through rotation. If a group is meeting on a one-time basis or infrequently, roles can be appointed at the beginning of each meeting, or it may be more feasible to conduct the meeting with only a leader to help move the proceedings along. At least one or two students from the organizing class(es) should attend each meeting along with their teacher or youth leader.

* Length - Keep meetings as short as possible. Set a time limit (maximum two hours, preferably less) and stick to it. Start meetings on time to promote promptness.

* Attendance Sheet - Have participants write their name, address, and phone number on the attendance sheet. Such information is useful for mailing lists and phone contact.

SAMPLE AGENDA #1

Kings Highway Anti-Litter Campaign

Agenda

Madison High School

March 23, 1979

3:30 pm

- I. What's Happened So Far. Short Summary.
- II. Problems to Solve
 - A. Publicity
 - 1. Posters
 - 2. Cans
 - 3. News release
 - 4. T-Shirts
 - B. Garbage Cans
 - 1. Availability
 - 2. When available
 - 3. What type
 - 4. Servicing
- III. Immediate Future
 - A. Beginning of Campaign
 - B. Service and pickup schedule
 - C. Get release together

SAMPLE AGENDA #2

Community Education Action Coalition

Agenda

Madison High School

March 9, 1980

2:30 pm

I. Curriculum Planning and Structure of Urban Studies Class

- * What's happening and what's being planned.

II. Brooklyn College Students

- * Summer Urban Institute Participation
- * Other Plans

III. Structure of CEAC

- * Community Board
- * Board of Trade
- * Role of Development Corporation

IV. Projects

A. Anti-litter campaign

- * Sweeps once a week? When start? What preparation needed?
- * Cans -- pilot program with six cans
- * Senior Citizen block watcher
- * Funding -- Con Ed, BUG, others

B. Environmental Arts -- Beautification

- * Adopt a Station
- * Triangle Parks
- * Murals -- Select a Site/Select a Mural
- * Sculpturing Found Objects
- * Madison Beautification Program
- * Target groups -- senior citizens, others -- make contact with them
- * Functions -- Who does what in environmental arts--organizing project
- * Expansion to Bed-Stuy and other areas
- * Decision-making process -- involving citizens

C. Other projects

C. Other Field Organizing Comments ¹⁸

1. Whatever strategies and publicity methods are chosen to motivate participation, it is essential that the project and participation methods be within the experience of the community in which the project is meant to operate. If flyers, posters, workshops, etc. are drawn up or conducted in a way not relevant to the citizens who are to become involved, the project is doomed to failure. It is important that organizers start where the people are in a psychological, social, and political sense. For example, using a petition campaign or protest rally at the very beginning of a project in a religious, conservative community rather than a slide show at a local town meeting might alienate rather than interest citizens.

2. Organizers should choose participation strategies which are exciting and enjoyable. Overly dry, serious interactions, e.g., too many meetings as opposed to an outdoor exhibit or fair, may simply cause citizens to lose interest and become bored.

3. It is important that all strategies be well-timed; e.g., a sweep-up that is being organized as part of an anti-litter campaign on a major thoroughfare should be held at a time that would not interfere with maximum storeowner business. All elements in the community should be consulted before a date and time is set so as not to alienate key groups.

4. During all events and in preparing all literature, organizers should concentrate on specifics -- the activities that can be developed to successfully help a project grow or change a situation for the better. Too many theories or abstractions, especially at the initial stage of organization, will bore many citizens and stultify real action.

5. Organizers should keep a log of methods used in developing a project, e.g., workshops, petitions, mailings, and include in the log the successes and failures of each strategy and its effect on the growth of the project.

6. It must be emphasized that if at all feasible, organizers should endeavor to develop multi-issue, multi-faceted projects to ensure broad-based support and long-term participation. It is important to concentrate on one or two project ideas at first, e.g., anti-litter, but as citizen participation grows and becomes more enthusiastic, it will be possible to stimulate involvement in other solid waste and environmental

¹⁸ Some suggestions taken from Rules for Radicals, Saul Alinsky, Vintage Books, pp. 126-142. Also, see note on Alinsky, p. 190.

projects as well. Again, this type of long-term growth is feasible where a school or youth organization is willing to make a long-term commitment to involve very capable youth in such a process.

UNIT E: EVALUATION

Lesson #1

Aim: To evaluate reactions and development of the student organizers.

Motivation: Each teacher or organizer or supervisor¹⁹ should meet at regular intervals with her/his organizing class or group and members of any available support group.

Discussion:

- a. Are we enjoying the organizing activities?
- b. How are we relating to other students in the school?
- c. What about our relationships with community groups in the neighborhood we are organizing in?
- d. How are we relating to the citizens we are involving in the project? What problems are we encountering in our individual relationships, interactions, etc. with storeowners and other citizens?
- e. Are we relating to the community's needs?
- f. What organizational skills are we utilizing?
- g. What else are we learning?

Followup:

* Through role-playing, discussion, etc. these questions should be examined. Solutions to problems can be proposed and analyzed by the group. The various project subcommittees may need to meet and go through similar steps of personal awareness and evaluation.

* An interesting area for discussion here is the question of the values that underlie any organizational effort. The organizing process that students have initiated could be utilized to promote or support any political ideal or human service and it would be significant for students to understand this and to analyze situations in history where organizing techniques have been used for negative purposes, e.g., for extreme political causes.

¹⁹ Just a reminder: If a teacher is not directing a class or club, the organizer/supervisor would refer to a college student supervising high school students or a group leader supervising a youth group.

Lesson #2

Aim: To determine the quality and quantity of participation in the project.

Motivation: A speaker from a small computer information technology firm on the storage, evaluation, and use of information.

Discussion:

a. Determine the numbers and kinds of people involved in the project. Use:

- * Records of attendance at workshops, meetings, events-- numbers and regularity.
- * Number of people on committees, patrols, etc.
- * Number of people occupying leadership positions.
- * The age groupings, ethnic backgrounds, community groups that participants represent.

b. Have the class or each project group draw up a participation summary. The summary should include a quantitative/- qualitative breakdown of participation. For example:

- * Initial participation would be those citizens who attended one or two events or participated in some minimal way but discontinued their involvement in the process soon after their first experience.
- * Intermediate or occasional participation would be those who persisted to some degree after an initial set of experiences, e.g., came to several meetings or workshops before terminating involvement or participated in an intermittent manner throughout the entire course of project development.
- * Final or ongoing participation would fit those persons who came to most meetings or events, assumed leadership or other functional roles, performed the tasks required by the project consistently, etc.
- * Each community and project will, of course, require different behavioral and managerial definitions at different levels of participation.

c. As an example of a participation analysis, a high school organizing group coordinated an aluminum can recycling project in an elementary school. Of the 350 students in the school, the breakdown was as follows (see Recycling Chart on p. 229):

- * Initial Participation: Students who brought in cans 3 times or less during the school year: 60 (17%).
- * Intermediate or occasional participation: Students who brought in cans 3-10 times: 60 (17%).
- * Final or ongoing participation: Students who brought in aluminum cans on a weekly basis and/or who came to some recycling team meetings or were class captains for some period of time during the school year: 30 (8.5%).
- * Total Student Participation: 150 out of 385 (42.5%).
- * Of the fifteen teachers in the school, all participated and were equally spread over the three participation categories.
- * Of the 500 parents whose children are in the school, about 200 (40%) participated initially, that is, they helped the children collect, clean, bag, and transport cans. Approximately 30 parents (6%) were involved in intermediate participation, attending some meetings, participating in recycling discussions at school executive committee meetings, etc. A core group of five parents (1%) helped coordinate the project from its inception. Thus, total parent involvement was 235 (47%).
- * The principal and other members of the school administrative staff participated actively.
- * A good indication of successful participation in the project would be to combine intermediate and final participation to get a figure for quantitative and qualitative involvement.
- * Thus, 90 students (27%) participated on a meaningful level, 35 parents (7%) were intensely involved, 10 teachers (67%) were involved in a consistent manner.
- * Total participation of any kind in the whole school population was 42% while the intermediate plus final figure was 16%.
- * These participation percentages for the school recycling program were relatively high compared to most new programs, but certainly other strategies are needed to increase participation.
- * These figures are not the only indices of participation. Qualitative factors like participation of key persons in the school administration -- the principal, school-community council president, etc. -- were important in ensuring the project's success. The core group of parents who helped plan and coordinate was a key factor. The project motivated a large number, 35 (out of about 60, or 60%) of the parents who actually work in the school to participate (as opposed to the parent-body as a whole). However, the organizers have yet to motivate a group of parents, students, teachers, etc. to take responsibility for the entire project so that it can function without outside student organizers from the high school.

Followup

As the preceding example demonstrates, both quality and quantity must be considered in evaluating participation. Some other aspects of project development to be analyzed are:

- * Is the project continuing?
- * Is the program institutionalized in the school or community?
- * What actual environmental changes have taken place? e.g., in the aluminum recycling project 2,000 pounds of aluminum were recycled, 45,000 cans didn't become garbage, 13,000 kilowatt-hours of electricity were saved, and \$400 was earned by the school.

Certain technical things should be done on an ongoing basis for evaluation purposes.

- * The mailing lists should be categorized, e.g., type of group, school district, community board area, press, etc.
- * Workshop and other group meeting statistics should be kept so that organizers know, for example, which workshop topics stimulated attendance and motivated participation.
- * Workshop participants should sign a sheet at each workshop giving their addresses and phone numbers, so that they can be polled if necessary.
- * Comparisons of participation stemming from various general strategies -- mail, meetings, block parties, events in different situations -- should be made and recorded. Even if numerical statistics cannot be kept, some written description in a log should be made so that future organizing groups can assess the potential of various strategies.

PS 3 Class Recycling Results *

For Recordkeeping and Evaluation

CLASS: Freddya / 209

MONITOR: Adam

MONTH: February 1979

NAME	1/23	1/24	1/25	1	2	Week Total	5	6	7	8	9	Week Total	12	13	14	15	16	Week Total	19	20	21	22	23	Week Total	26	27	28	1	2	Week Total	Month Total	
June Egan																																
Andrea Bendewald	21	-	-	-	-	21	-	13	-	-	-	13	1	-	-	-	11	45	-	7	-	-	4	23	4	2	-	-	35	79		
Alison Aze	3	-	7	-	3	13	7	-	2	-	2	80	-	28	14	-	9	45	-	3	4	-	7	-	4	1	-	1	146			
Jake Haber	1	3	4	3	1	12	7	18	8	1	-	34	10	7	8	11	30	-	36	26	9	71	35	9	-	38	-	80	193			
Amos Brown	1	-	-	-	-	1	-	-	-	-	-	0	-	-	-	-	-	-	3	1	-	-	3	-	12	26	-	38	46			
Scott Jeffrey	1	48	8	1	-	58	-	-	-	38	-	33	-	-	-	-	-	-	-	3	9	-	3	-	1	-	-	7	101			
Michelle	45	55	49	67	43	258	2	6	1	1	3	13	12	-	3	1	16	-	4	1	1	1	7	8	-	-	-	-	302			
Carole Shurling	-	5	1	1	-	7	39	-	-	1	-	34	-	-	-	-	-	-	4	1	-	12	15	-	-	1	-	1	59			
Carole Beyer	-	9	4	1	-	14	3	7	-	-	-	10	-	-	-	-	-	-	1	-	-	1	2	-	-	20	-	20	46			
Ursula	-	6	6	-	-	12	-	-	-	-	-	0	-	-	-	-	-	-	-	-	-	1	1	-	-	-	-	0	13			
Anna Lohdike	-	7	9	32	-	48	-	-	-	-	15	13	-	-	-	-	-	-	-	2	2	-	20	22	9	8	-	39	134			
Lynne Mace	-	12	-	13	-	25	-	-	-	-	-	0	-	-	-	-	-	-	-	-	-	-	0	-	-	-	-	0	25			
Kenny Ryley	-	3	1	-	1	5	-	1	-	-	-	1	-	-	-	-	-	-	-	6	1	-	7	-	6	-	-	6	20			
Chim Comano	-	4	4	-	-	13	-	-	-	-	-	0	-	-	-	-	-	-	-	-	-	-	0	-	-	-	-	0	13			
Betsy Simon	-	4	14	-	11	31	46	-	-	-	-	46	-	-	-	-	-	-	-	21	-	-	21	-	-	-	-	0	101			
Alison Quata	-	-	14	-	-	14	-	-	-	-	-	0	-	-	-	-	-	-	-	-	4	4	-	-	-	-	-	-	18			
Aaron Miller	-	-	9	-	-	9	-	7	-	-	-	7	-	-	-	-	-	-	-	-	-	0	-	50	-	-	-	50	64			
Jays Bruce	-	-	23	-	-	23	-	-	-	-	-	0	-	-	-	-	-	-	-	-	-	0	-	-	-	-	-	-	23			
Melissa Josephine	-	-	36	20	-	56	-	-	-	-	-	0	-	-	-	-	-	-	-	-	-	0	-	-	-	-	-	-	50			
Rick Moore	-	-	3	-	-	3	-	-	-	-	-	0	-	-	-	-	-	-	-	-	-	0	1	-	-	-	-	1	3			
Barbara Brantel	-	-	14	-	-	14	-	-	-	-	-	0	4	1	-	-	1	-	-	-	-	0	-	-	-	-	-	-	15			
Ann Rutledge	-	-	-	-	-	1	-	44	3	6	54	-	72	-	-	-	12	-	-	6	-	7	-	-	-	-	-	-	73			
Tommy	-	-	4	-	-	4	-	-	-	8	12	-	-	-	-	-	-	-	-	-	11	12	-	-	-	-	-	-	214			
CLASS TOTALS	72	126	164	14	58	632	168	66	55	110	211	369	155	117	71	286	-	-	-	5	-	317	-	90	60	38	-	-	1707			

* Number of cans.

SPECIAL SECTION ON LETTER-WRITING AND PETITIONING

Introduction

Many Americans do not participate in the democratic process. A large number of citizens do not vote, either in local or national elections (52.3% of the eligible voters voted in the 1980 presidential election, according to the League of Women Voters) and the percentage was only slightly higher (54%) in the '84 election. In 1988, slightly less than 50% voted. Relatively few citizens frequently write their elected officials to express their views on issues.* In fact, many Americans cannot even name their congressional representatives or senators. Dialogue between citizens and appointed officials of service agencies like the department of environmental protection or housing is even less frequent.

A letter writing/petitioning campaign can be an effective means of educating students and citizens on a particular environmental issue, and encouraging them to participate in the democratic process. A campaign can take the form of a letter-writing drive, a phone campaign, or a petition collection. Of the three, letter-writing is the most effective means of communicating with representatives.

Each letter that a senator, a representative or local legislator receives is read and answered, and its views are recorded. A single letter is felt by the recipient to represent the views of up to 10, 50, 100, or even 200 other constituents. If 200 letters are written on an issue, an elected official could estimate that up to 40,000 voters hold the same views. Appointed public officials are very impressed when they receive even a few letters on an issue.

A campaign could work this way: students could select an issue (not necessarily a piece of legislation, but a local environmental issue or service improvement they wish to draw attention to), study the issue thoroughly, form an opinion, and make presentations to fellow students and community groups urging them to write letters to government agency officials or to legislators. The students would be responsible for developing and organizing the campaign, with assistance from a teacher or other supervisor. The students could also write their own letters. Petitions can accompany the letter-writing drive.

*We are aware, of course, that many legislators and some appointed bureaucratic officials do receive large numbers of letters and that many neighborhood groups are effective at communicating with public officials. Still, with all of this, the majority of Americans are not participants in these processes on any regular basis.

Letters written to appointed officials can be copied and sent with a cover letter by teachers or group leaders to their elected representatives who might then also respond to the students and write to the appointed official as well.

A letter-writing campaign can fill several important functions: students will be educated on an environmental issue; they will gain organizing, and in particular, public speaking experience; other students and citizens will be educated on the issue; and hopefully a substantial number of letters directed at key legislators and/or bureaucratic officials will be generated by the campaign. Students interested in environmental problems and in organizing, but not necessarily in "street level" projects, could find a ready outlet for their interest in such a campaign.

It must be emphasized that a letter-writing/petitioning campaign has to have the support of the students. The idea may be introduced by the teacher initially, but students must be enthusiastic about participating. A letter-writing campaign must not be used to manipulate students' political views, or to use students as a lobbying tool. A campaign should provide a forum for discussion of all sides of the issue, out of which a variety of opinions is formed and a letter-writing campaign developed. The students become letter writers and organizers and are motivated to elicit student and community interest in the issue being studied. They are working for change in a specific and highly educational way.

In CENYC's Training Student Organizers Program, student letter-writing efforts have been instrumental in convincing the NYC Transit Authority to place noise abatement equipment on elevated trains, and in stimulating the New York State Department of Environmental Conservation to agree to afford better protection for wetlands adjoining streams and rivers that flow into reservoirs that provide drinking water for 10 million people in New York City and Westchester County.

Lesson #1

Aim: To learn how and why citizen participation in the political/legislative process is important.

Discussion:

- a. Ask students to name their senators and congresspersons.
- b. Ask student to name their state representatives.
- c. Ask students to estimate the percentage of eligible voters who voted in the last presidential election.
- d. Ask students to name the commissioners of the local

service departments: sanitation, police, fire, education, environmental protection, etc.

e. Ask students if they know of any local or national environmental laws or proposed legislation and if so, to explain the purpose of the law(s).

f. Discuss local environmental issues with the students, and the effect that active citizen participation could have upon the issue(s).

Lesson #2

Aim: To organize a letter-writing campaign in the school and community.

Discussion:

a. Discuss with students the municipal, state, and federal legislative process and how it works.

b. Discuss how various municipal, state, or federal agencies make decisions.

c. Determine as a class the particular officials that should be targeted in the campaign.

d. Develop an effective presentation that they can give, as discussed in Part I units and lessons, and in Part II, pp. 220-221.

e. Develop an outreach strategy within the school, assigning students to speak before selected classes, clubs, etc.

f. Develop an outreach strategy for the community, assigning students to speak before the PTA, community organizations, etc.

g. Develop a fact sheet or sample letter to give to people.

h. Develop a system to monitor accurately the number of letters written.

i. Role-play petitioning if that strategy is to be used.

j. Check League of Women Voters Guide or other manuals on proper manner of addressing public officials and length/style of letters.

Followup:

It is important to carefully monitor the number of letters written. Students can give their presentations to a class or community group, and should collect the letters the same session, if possible, or establish a procedure for collecting and sending letters. This way, an accurate gauge of the campaign's effectiveness can be maintained.

To summarize, the main goal of a letter-writing campaign is educational. Students should be made aware that democracy is in danger if citizens do not participate in their government by following the issues, by writing their representatives both

elected and appointed, and by voting in elections. The aim is not to foster a particular political orientation in students, but to effect a change in attitudes about the process itself. If students can be made aware of the political process, if they can be made aware of the importance of communication with representatives, and if this awareness engenders in them a more positive attitude toward active participation in their society, then a letter-writing/petitioning¹⁹ campaign can be deemed a success.

¹⁹ Petitioning has accompanied some of the letter-writing efforts by students participating in TSO and has been the main project a few times. We've used all the techniques mentioned in this manual, e.g., role-playing, practicing petitioning in the school and community, etc., before the students actually do the petitioning. The choice of issue, preparation of the petition and selection of officials to send it to follows the same kind of educational principles mentioned in preceding lessons.

Makuta Kamora
155 W. 162nd Street
Apartment 4 I
Bronx, New York 10452

December 3, 1987

Commissioner Thomas C. Jorling
New York State Department of
Environmental Conservation
50 Wolf Road
Albany, New York 12233

Dear Commissioner Jorling:

Thank you for the help you have given the people of New York State and for your role in maintaining a healthy environment.

I am concerned about keeping our drinking water healthy and unpolluted. My feelings about the wetlands is that houses should not be built on them. The wetlands help to control floods. They serve as buffers during storms; they anchor and hold down soil, protecting the storm-caused erosion.

They can support huge numbers of plants, insects, birds, fish and other animals.

The thick vegetation provides shelter for breeding and nursery sites, and food sources for migratory birds.

I think we should reclassify the wetlands to give them more protection.

Thanks for listening.

Sincerely,

Makuta KamOra

Errol Bell
974 St. Nicholas Av.
New York, N.Y.

December 2, 1983

Governor Mario Cuomo
The Executive Chamber, Capitol
Albany, N.Y. 12224

Dear Governor Cuomo,

I am a student at A.P.R. Campus High School and I want to thank you for your support of the Rapid Transit Noise code which was passed by the State Legislature in 1982.

I am very concerned about the noise level in the subways because I ride the trains almost every day. For example, my mother and I were riding the train to my aunt's house in Brooklyn and the noise level in the train was so high that I wasn't able to hear my mother telling me to get off the train because we had reached our destination. Another time I was in the subway station waiting for the number 2 train to arrive. An announcement was made, but due to the excessive noise in the station, I didn't hear clearly what was said. I waited for almost an hour before the train finally arrived. That isn't all. The train I was on had to wait fifteen minutes more between stations before I finally heard that the train ahead had a mechanical failure. The announcement which I missed was probably made to inform passengers about delays on the number 2 train.

My Law class made a trip to the subway station at 145th Street on St. Nicholas Avenue. A group of students had decibel meters to check the noise level in the station. The results of our survey showed that the D and A trains entering and leaving the station had a noise level average of 93 decibels. While riding the D train to 59th Street, our study showed 94 decibels between 125th and 59th Streets with a range between 90 and 101. Between cars, noise levels were between 101 and 110 decibels. Near an open window, decibel levels reached 102.

The noise abatement study required by the bill and the overall enforcement of the bill are of great concern to my family and I.

Sir, I sincerely hope you will give these matters your fullest attention.

Please reply and tell me what you are going to do about the situation.

Sincerely,

Errol Bell

REFERENCES

How to Make Citizen Involvement Work, Duane Dale, Citizen Involvement Training Project. University of Massachusetts Press, Amherst, 1978.

Powerline: The First Battle of America's Energy War. Barry M. Caspar and Paul David Wellstone. The University of Massachusetts Press, Amherst, 1981.

Profiles of Participation, a Workbook on Citizen Organization and Action, National Municipal League, New York, New York, 1979.

Reaching Up, Reaching Out -- A Guide to Organizing Local Solar Events, Energy Research Institute, U.S. Department of Energy, Golden, Colorado, 1979.

Reveille for Radicals, Saul David Alinsky. University of Chicago Press, Chicago, Illinois, 1946.

"Special Issue on Organizing Neighborhoods," Social Policy Magazine, September/October 1979. Vol. 10, No. 2.

The Neighborhood Organizers Handbook, Rachelle B. and Donald I. Warren. University of Notre Dame Press, Notre Dame, Indiana, 1977.

War Resisters League Organizers Manual, Ed Hedemann, War Resisters League, New York, NY, 1981.

