

The University of Akron
IdeaExchange@UAKron

Proceedings from the Document Academy

University of Akron Press Managed

November 2014

Transmedial Documentation for Non-Visual Image Access

Melody J. McCotter

University of North Texas, melody.mccotter@unt.edu

Please take a moment to share how this work helps you [through this survey](#). Your feedback will be important as we plan further development of our repository.

Follow this and additional works at: <https://ideaexchange.uakron.edu/docam>

Part of the [Disability and Equity in Education Commons](#), [Graphic Communications Commons](#), [Instructional Media Design Commons](#), [Library and Information Science Commons](#), [Photography Commons](#), [Special Education and Teaching Commons](#), [Visual Studies Commons](#), and the [Vocational Rehabilitation Counseling Commons](#)

Recommended Citation

McCotter, Melody J. (2014) "Transmedial Documentation for Non-Visual Image Access," *Proceedings from the Document Academy*: Vol. 1 : Iss. 1 , Article 10.

DOI: <https://doi.org/10.35492/docam/1/1/10>

Available at: <https://ideaexchange.uakron.edu/docam/vol1/iss1/10>

This Conference Proceeding is brought to you for free and open access by University of Akron Press Managed at IdeaExchange@UAKron, the institutional repository of The University of Akron in Akron, Ohio, USA. It has been accepted for inclusion in Proceedings from the Document Academy by an authorized administrator of IdeaExchange@UAKron. For more information, please contact mjon@uakron.edu, uapress@uakron.edu.

Introduction

How can we make image documents more accessible for the individual who is blind or visually impaired? One approach is to translate the document into a different format or medium so that the user can employ an alternative sensory modality. We can call this conversion process a transmedial translation, or a *transmediation*. The term is not used in the sense of creating a multitude of stories around one story in many different media, as has been described in literacy literature (Scolari, 2009). It is, however, tangentially related in that a document in one medium is presented in another medium. The biggest difference between these two processes is the desire in this situation to adhere as closely as possible to the original document rather than to create or expand upon narrative arcs. Perhaps the term *intermediation* would be more apt as it denotes a journey *across* from one state to another. The *intermediary* stands *between* these two states. This term is also problematic, as it is commonly used to refer to the resolution of legal disputes via a neutral third party. For now let us call it transmediation and explore the concept without too much rumination over the label.



Italian Still Life (B). (1981) Irving Penn.

The questions that arise when we consider this process of making an image accessible are many, but among them are: Is it the same document once we've converted it to an audio narrative about the work, or a 3D topographic map of an artwork, or a musical interpretation? If it is not the same document, how truthful can or must the transmediation be to the original work? If we re-create the original circumstances (content of the work or subject or object), is that a useful representation of an image of the original subject? (i.e., the model of the cheese

and food items depicted in Penn's photograph) This question leads to many other questions. I hope to address them in more depth in future writing. Perhaps the act of capture or re-presentation is what makes a representational work a work of art, and so by documenting merely its content or subject matter, the object of the work, we sell the end user short. We omit the connotative aspects: those many rich and complex decisions the artist made that turn it into a piece of art.

I work with users who have low vision to determine if these image re-documentations are indeed useful and what means of representation are preferred. We now convert textbooks, for example, to audio books or electronic texts readable by special equipment or software. Although access to print media for those with vision loss has improved significantly in the last few decades, access to images within texts and beyond has remained problematic. These images also present an interesting document case. They are part of a document (the textbook as a whole), but can also function as documents independently. They may have a history apart from the work within which they're found. They may have previously existed in a different context, and might be reproduced with or without permission from copyright holders. These documentary complexities require decisions of the transmediator, including choices about level of detail, interpretation, alternative medium, and the introduction of externally sourced information.

There is an increasing effort among museum and cultural heritage institutions to support the experiences of blind or partially sighted visitors. Visual collections can be presented in a multiplicity of media to follow a Universal Design, Inclusive Design, or Design for All approach. This body of work generally relates to "the conscious and systematic effort to proactively apply principles, methods and tools, in order to develop IT&T products and services which are accessible and usable by *all* citizens, thus avoiding the need for a posteriori adaptations, or specialised design." (Stephanidis, 1988) These types of exhibits are based on the idea that any visitor, whether disabled or not, might have a richer experience with the collection by interacting with it via several senses. For example, The Meadows Museum at Southern Methodist University in Dallas, Texas holds occasional multimedia events aimed at making their collection more accessible and enjoyable via a multiplicity of sensory modes (Ramirez, 2014). Visitors can experience the exhibit regardless of age, visual acuity, or hearing ability.

Similarly, transmediation from a visual document to a textual document can facilitate access via the senses of sound or, in the case of Braille text, touch. Other tactile approaches such as three-dimensional models are also useful, and some transmediations provide access via multiple senses. If we want to reach beyond

tactile approaches, taste and smell are at our disposal. Transmediation can also be employed at a visual document's creation. Some photographers who are blind now create photographs enhanced with audio tracks to yield an "audiophotograph," thus facilitating later retrieval by the photographer in an eye-free manner (Harada, S., Sato, S., Adams, D.W., Kurniawan, S., Takagi, H., & Askawa, C., 2013). These transmediations collectively form a new document. Some we might also deem documents individually, others we might not. The existence of each document within a context of other related documents creates a document family (Wilson, 1968).

An image can contain many facets and aspects that might be candidates for description. If the method for access is to have a sighted person describe or explain what is in the picture, the describer or transmediator must determine which aspects of the work are important for the user and present them to him or her. They may say "There is a white ball that appears to be cheese, and on top of it sits an oblong red thing that is probably a tomato, and a smaller oblong thing on its side that is a green olive. It doesn't appear to be pitted." This seems like a good description, unless the user is trying to answer an exam question about the choice of soft lighting in the photo and its impact on the shadows. The facets of the work that are elected for description could vary from one transmediator to the next based on preference, personal background, time constraints, and understanding of the end user or his/her task

A Transmediated Document

The exhibit document I created for the Muse Lab at Kent State is intended to provoke thinking about what sensory inputs we privilege as documents and to demonstrate a family of documents. It was not just one instantiation, but several that represented the source document, the Irving Penn photograph *Italian Still Live (B)*. Braille text was used to provide access to a textual transmediation and an audio track allowed visitors to hear that same text via headphones. There was also a three-dimensional replica constructed of the foods related to the collective work that could be touched or smelled. These provided examples of ways of understanding documents through senses other than sight. It also demonstrated practical concerns arising from differences in the documents such as perishability, portability, and vulnerability to gravity.

The cheese in the photograph looked like a ball of fresh mozzarella to me, but this was not certain. The tomato looked like a Roma tomato, and the flavor of the green olive in the image could not be discerned, so I chose the kind that looked most similar and that happened to be available at the Acme store in Kent the day before the exhibit opened. These are some places where inaccuracy (a kind of

noise) could have been introduced to the process (Shannon & Weaver, 1949).



Photograph by Brian C. O'Connor, 2014

We can see examples of other challenges to representation when we view the mosaic *Minerva of Peace* on the wall of the Thomas Jefferson building of the Library of Congress (Miller, 2013; Vedder, 1896).



(Vedder, 1896; Miller, 2013)

The Koen Wessing photograph, *Nicaragua, 1979*, depicts the ironies and tragedy of war in a subtle yet striking manner.



Nicaragua, 1979 by Koen Wessing.

Asher Durand's (1848) early American landscape painting offers many details depicting rural life in Dutchess County, New York in the mid-nineteenth century.



(Durand, 1848)

How do we best capture the many facets and details of these and other visual works and represent them to someone who cannot see? Choices must be made about what to draw out, what to index, and what to leave behind. These choices should be based upon the requirements of the user in a particular instance to be of maximum practical use (Wilson, 1968). The person, or perhaps machine running a human-written program, makes choices about what is of interest in the work and what is not. This can be impacted for better or worse by the individual's or the transmediator's worldview, past experiences, biases, and perceptions of the intended use. Perhaps no two describers would select the same words to describe a given image (O'Connor, Kearns & Anderson, 2008; Anderson, Kearns & McCotter, 2009).

These transmediations might be considered meta-documents (i.e., documents about documents) intended to serve as informing objects about the work. Or perhaps they are intended to serve as stand-in documents for the original, as surrogates. We do not know yet whether they would function better as a meta-document to describe or elucidate the various aspects of the work in a visual medium, or whether they could serve as a replica that fully represents all aspects of the original work. I believe they cannot be identical to the original in another medium; information is lost in the transmediation. They can, however, point out those aspects that are deemed important or essential for use and have been selected for representation. Perhaps with a multiplicity of perspectives and transmediators, a work can be more fully described, with many views and interpretations lending a richness of perception.

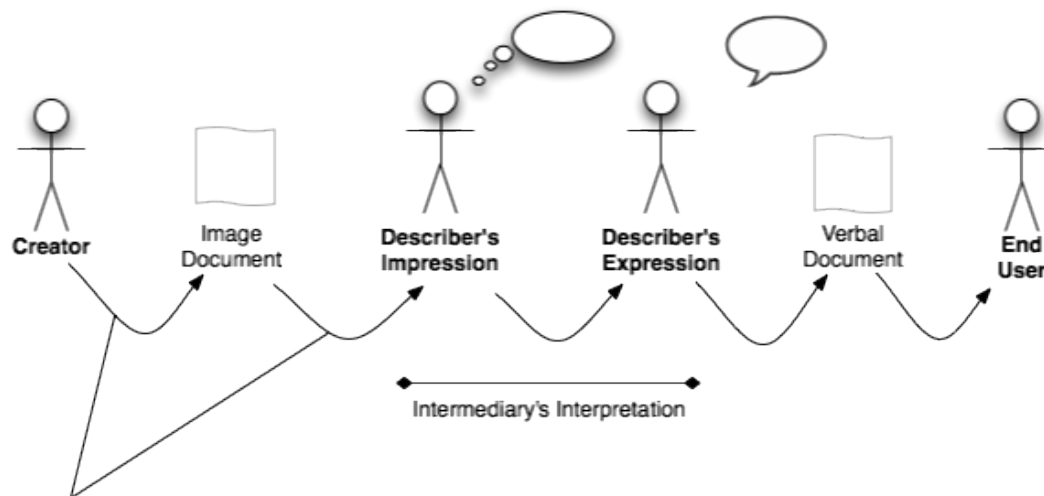

Potential Noise Introduction
 An expanded view of what constitutes a document allows us to realize the complexities inherent in transmediation (Buckland, 1997). The image is a document and is not equivalent to the textual document describing it. Yet the

“primary” document is of essentially no use to the blind viewer without some form of transmediation. A means of observation essential to the object’s function as a document is absent. Any attempt to make that leap from visual medium to other medium is prone to error. However, image use is essential for successful participation in modern life, so we seek a solution to this problem.

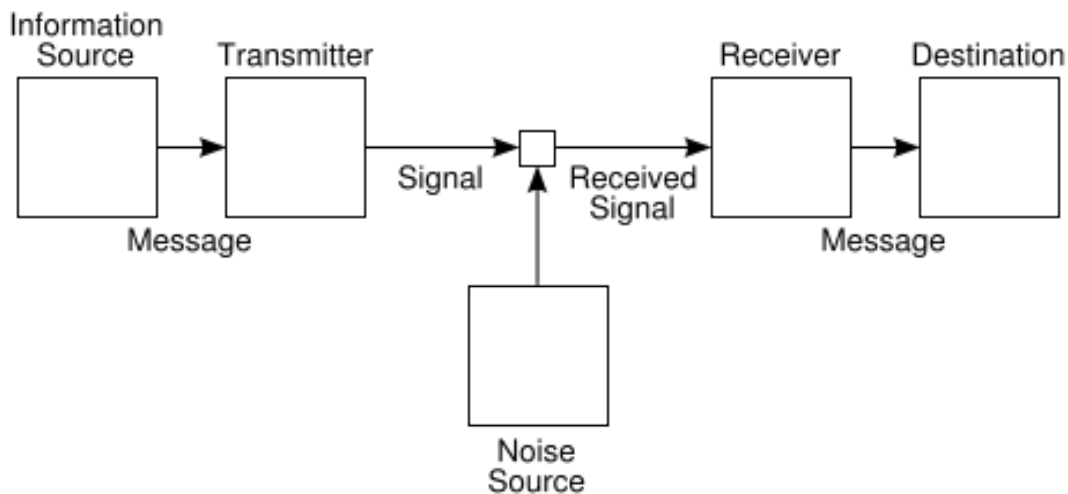

(Shannon & Weaver, 1949. Retrieved from http://en.wikipedia.org/wiki/A_Mathematical_Theory_of_Communication)

I have adapted Shannon’s model, *The Mathematical Theory of Communication* (Shannon & Weaver, 1949), explaining his notion of noise interfering with communication in a channel from sender to receiver, to include non-mechanical communications, and the very messy human being as node. We can imagine the message as image passing to a transmediator from the author or publisher or document producer, who must first perceive or take in the image. This is susceptible to any imperfections or peculiarities of the transmediator’s perceptual powers. He or she then processes this information and attempts to describe it to the visually impaired end user. This requires the intermediary’s accurate perception of the end user’s need and her own ability to faithfully articulate what she has perceived. Another transition still remains for the system to be complete, and again it has the potential to introduce noise, whether error by omission, addition, or vagueness. What the transmediator says or writes needs to accurately portray the image to the user for the intended use. In addition to these issues and potential pitfalls in the human process, the transfer from visual to textual is inherently problematic. An image is not a word, a word not an image (O’Connor, 1984; O’Connor, O’Connor & Abbas, 1999). It strikes at once, or nearly at once, while a text rolls out gradually in a narrative stream (Barthes, 1981). The subtlety

of an image or harshness of its stark message - denotative aspects - are difficult to explain, and subjective to the viewers past experiences, personality, preferences, and thus vulnerable to corruption, or noise. My variant of the Shannon Model demonstrates how the transition from one medium to another via an intermediary creates additional points whereby noise can be introduced. This is a lossy process, or it could be “gainy”. It is messy, yet necessary.

Conclusion

An image has its own cultural context and connection with the viewer, it’s own myriad associations and place in the bibliographic universe (Greisdorf & O’Connor, 2008) Words likewise have their own contexts, and cannot map directly to an image. These are the problems that arise when attempting to transmediate from image to word, be it spoken or written in the Latin alphabet or Braille. In attempting to transmediate, or represent a document via a surrogate document created in another medium, one can introduce noise or corrupt the message. Therein lies the challenge of image description.

References

- Anderson, R.L, Kearns, J. & McCotter, M.J. (2009) "A Quantitative model of ambiguity." Presented at DOCAM 2009, University of Wisconsin Madison.
- Barthes, R. *Camera Lucida*. (1981) New York, NY: Hill and Wang.
- Buckland, M. K. (1997). What is a "document"? *Journal of the American Society for Information Science*, 48, 804-809.
- Durand, A.B. (1848). *Dover Plains, Dutchess County, New York* [Painting]. Retrieved from http://americanart.si.edu/images/1978/1978.126_1a.jpg
- Greisdorf, H. F., & O'Connor, B. C. (2008) *Structures of image collections: From Chauvet-Pont-d'Arc to Flickr*. Westport, Conn.: Libraries Unlimited.
- Harada, S., Sato, S., Adams, D.W., Kurniawan, S., Takagi, H., & Askawa, C. (2013). Accessible photo album: Enhancing the photo sharing experience for people with visual impairment. 2127 - 2136. *CHI 2013: Changing Perspectives*, April 27- May 2, 2013. Paris, France.
- Miller, D. (2013). *Library of Congress mosaic of Minerva of peace* [digital photograph]. Retrieved from <https://www.flickr.com/photos/fdphotovideo/8553410849/>
- O'Connor, B. C., O'Connor, M. K., & Abbas, J. M. (1999). User reactions as access mechanism: An Exploration based on captions for images. *Journal of the American Society for Information Science*, 50(8), 681-697.
- O'Connor, B., Kearns, J. & Anderson, R.L. (2008). *Doing things with information: Beyond indexing and abstracting*. Westport, CT: Libraries Unlimited.
- O'Connor, B. C. (1984) *Access to film and video works: Surrogates from moving image documents* (Doctoral dissertation).
- Penn, I. (1981) *Italian Still Life (B)* [photograph]. Retrieved from <http://www.christies.com/lotfinder/photographs/irving-penn-italian-still-life-new-5355246-details.aspx>
- Ramirez, M. (2014, March 26). Museum takes art to the blind – and beyond. *The Dallas Morning News*, pp. 1A, 7A.
- Scolari, C.A. (2009). Transmedia storytelling: Implicit consumers, narratives worlds, and branding in contemporary media production. *International Journal of Communication*, (3), 586 – 606.
- Shannon, C. E., & Weaver, W. (1949). *The Mathematical theory of communication*. Urbana, IL: University of Illinois Press.
- Stephanidis, C., Salvendy, G., Akoumianakis, D., Bevan, N., Brewer, J., Emiliani, P. L., Galetsas, A., Haataja, S., Iakovidis, I., Jacko, J., Jenkins, P., Karshmer, A., Korn, P., Marcus, A., Murphy, H., Stary, C., Vanderheiden, G., Weber, G., & Ziegler, J. (1988). Towards an Information Society for

- all: An International R&D agenda. *International Journal of Human-Computer Interaction*. 10(2). 107-134.
- Vedder, E. (1896) *Minerva* [mosaic]. Library of Congress Thomas Jefferson Building, Washington, D.C.
- Wessing, K. (1979) *Nicaragua, 1979* [photograph]. Retrieved from <http://image.invaluable.com.global.prod.fastly.net/housePhotos/sothebys/78/108378/H0046-L00905144.jpg>
- Wilson, P. (1968). *Two kinds of power: An essay on bibliographical control*. Berkeley, Cal.: University of California Press.