

## The University of Akron IdeaExchange@UAkron

---

Williams Honors College, Honors Research  
Projects

The Dr. Gary B. and Pamela S. Williams Honors  
College

---

Spring 2019

# Examination of Ice Impactor and Mold

Matt Wilson  
[mjw148@zips.uakron.edu](mailto:mjw148@zips.uakron.edu)

Please take a moment to share how this work helps you [through this survey](#). Your feedback will be important as we plan further development of our repository.

Follow this and additional works at: [https://ideaexchange.uakron.edu/honors\\_research\\_projects](https://ideaexchange.uakron.edu/honors_research_projects)

Part of the [Ocean Engineering Commons](#)

---

### Recommended Citation

Wilson, Matt, "Examination of Ice Impactor and Mold" (2019). *Williams Honors College, Honors Research Projects*. 868.

[https://ideaexchange.uakron.edu/honors\\_research\\_projects/868](https://ideaexchange.uakron.edu/honors_research_projects/868)

This Honors Research Project is brought to you for free and open access by The Dr. Gary B. and Pamela S. Williams Honors College at IdeaExchange@UAkron, the institutional repository of The University of Akron in Akron, Ohio, USA. It has been accepted for inclusion in Williams Honors College, Honors Research Projects by an authorized administrator of IdeaExchange@UAkron. For more information, please contact [mjon@uakron.edu](mailto:mjon@uakron.edu), [uapress@uakron.edu](mailto:uapress@uakron.edu).



# Examination of Ice Impactor and Mold

Honors Research Project

Advisor: Dr. K.T. Tan

University of Akron Department of Mechanical Engineering

Matt Wilson, 2734999

April 26, 2019

# Table of Contents

1 Introduction.....	2
1.1 Abstract.....	2
1.2 Background.....	2
1.3 Motivation.....	3
2 Methodology .....	3
3 Results and Discussion .....	5
4 Conclusion .....	17
5 References.....	17

# 1 Introduction

## 1.1 Abstract

This research project investigates impact and damage response of composite sandwich structures impacted with solid ice at extreme low-temperature. Composite sandwich structures of carbon fiber reinforced polymer sheets lining a polyvinyl chloride foam core are subjected to low-velocity impact at arctic temperatures. This impact will be delivered by a solid ice tool-tip via a drop impact testing machine. Data and test results acquired will be composed into a research report that will be submitted to The University of Akron and published in a scientific journal. This project builds upon the earlier study by Elamin, Li, & Tan (2018).

## 1.2 Background

The process of today's shipping and sea travel utilizes several different commercial channels. These channels will likely be expanding in the future. As evidenced by Figure 1, arctic passages exist that are currently only traversable by special ice-breaking ships. However, warmer climates are projected to melt large areas of ice, opening faster shipping channels for use by standard ships. Seafaring vessels, at large, are beginning to follow a trend in the use of polymers, specifically composite sandwich structures, for vessel construction. This trend incites a question of how these polymers react to extreme low-temperature conditions.

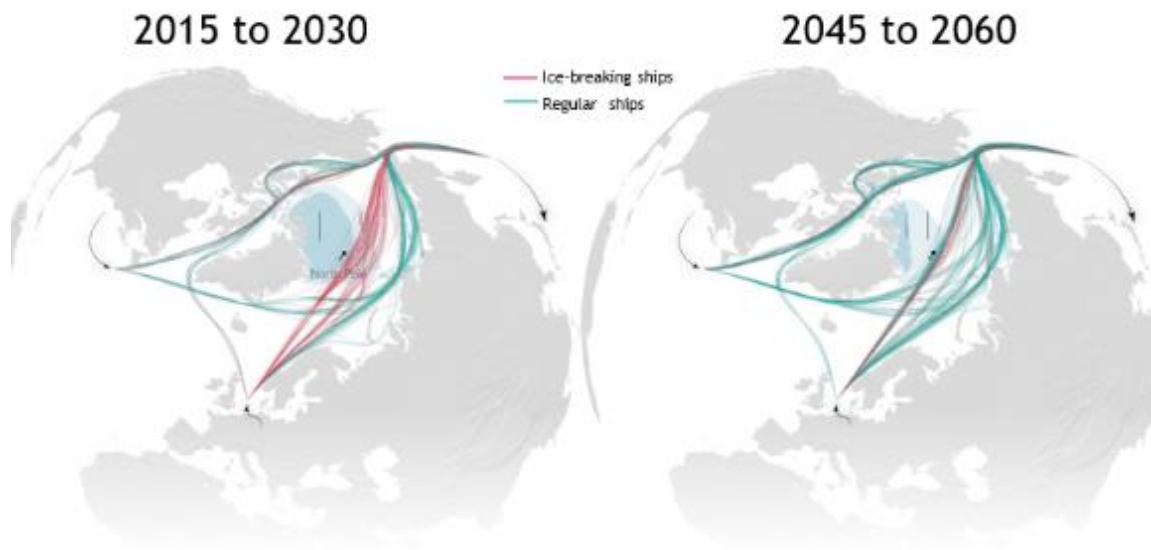

*Figure 1.* Arctic shipping lanes in present and future.

A key examination into the aforementioned phenomenon was conducted by Elamin, Li, and Tan (2018). Composite sandwich structures were exposed to extremely low temperatures, as low as  $-70\text{ }^{\circ}\text{C}$ , and impacted with a steel impact head. The low temperatures were made to simulate arctic conditions. Specimens were found to exhibit markedly less impact strength and more severe surface damage when tested at extreme low temperatures. Despite the thoroughness of this previous work, it has been found that improvements to testing procedure can be made.

### 1.3 Motivation

For previous work, testing with steel impact head represents an “ideal worst case” scenario. In that case, the impact is conducted using a nearly rigid impactor against composite sandwich structures. Motivation for this research report lies in creating a more realistic testing procedure. Given the prevalence of moderately-sized ice pieces submerged within arctic waters, an impact by ice is likely during service life of a seafaring vessel. Thus, an examination into ice impact on composite sandwich structures should be conducted.

Ice impact represents a more realistic scenario for testing. In this case, it introduces consideration of a less-than-rigid impactor. The objective for this research was then to create and/or modify current equipment to support a fully ice impactor head. A key resource in creation of an ice impactor mold, specifically, was provided in work by Prato and Longana (2018). Then, that equipment would be used to conduct impact testing on composite sandwich structures, along with collection and analysis of data.

## 2 Methodology

Molds for the ice impactor would require specific geometries, best achieved through use of CAD software in conjunction with 3D printing technology. The SolidWorks CAD program was used in design of various molds and adapters used in testing procedure. Two different 3D printing machines were used for manufacturing, each at different stages in the project. The first was a HICTOP 3D printer, and the second was a Stratasys Objet260 3D printer (both shown by Figure 2). Freezing of ice specimens was done in a Dometric electric freezer, shown by Figure 3. Freezing temperature for specimens was held as  $-8\text{ }^{\circ}\text{C}$ , and freezing time was one week. All impact testing was conducted with an INSTRON CEAST 9350 Droptower impact testing machine. The INSTRON machine is shown in Figure 4. Further still, an adapter would be necessary for the INSTRON impact tester, one that could attach to the INSTRON machine and hold an ice impactor from the ice mold. This adapter was also designed in SolidWorks but was machined out of steel.



*Figure 2. Left to right: HICTOP and Objet260 3D printers.*



*Figure 3. Dometic freezer.*

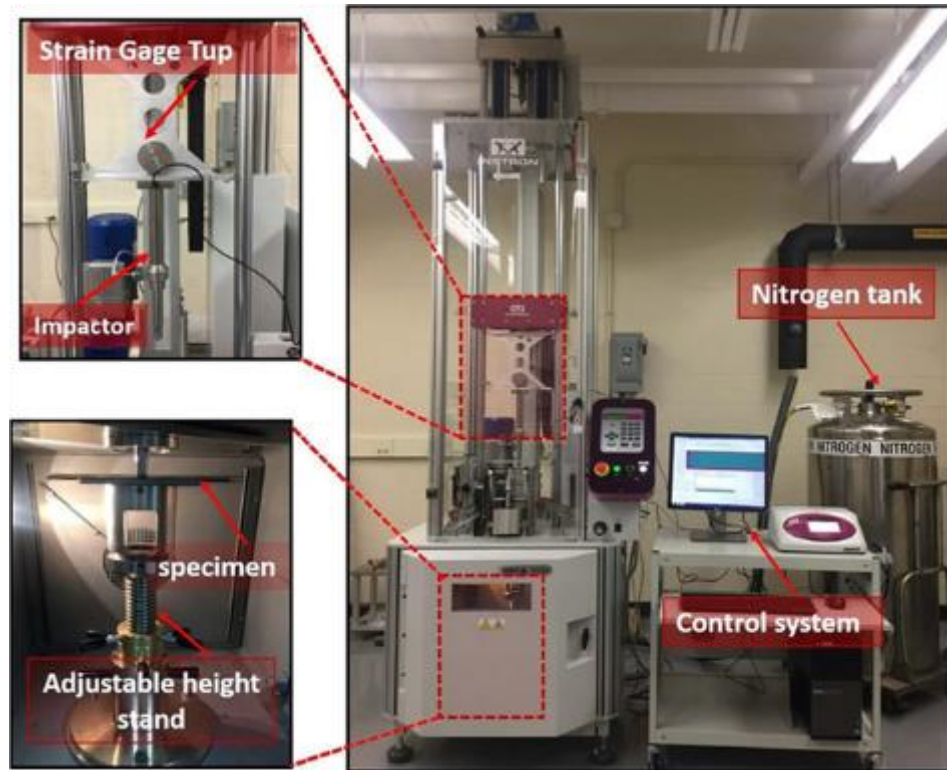

Figure 4. INSTRON impact test machine.

The key research concept in question was the creation of a functional mold/adapter setup. The mold would have to be designed to specific dimensions. It would also need to produce solid specimens and be designed in such a way that the ice impactor could be removed without compromising ice structure. The adapter would need to fit dimensions of the mold while also attaching to the INSTRON machine. However, it was determined that the adapter should also be modular, fitting to geometry of many different potential sizes of molds and ice impactors. Preparation of ice samples also formed an important facet of experimental procedure. To produce solid and consistent ice specimens, a set temperature and freezing time would need to be held constant for each ice impactor in a test set.

### 3 Results and Discussion

There were three major points in this research project. The first was an initial foray into ice properties and preliminary mold design. Second, a mold and adapter were created through trial and error as well as implementation of newer technology. Third, the mold and adapter were redesigned to address issues in previous test runs, and the freezing process was refined. It is important to note that this report contains only information pertinent to creation of a functional mold/adapter setup. Testing of composite sandwich structures using the ice impactor represents future work and is not covered in this report.

The initial stage of research involved gaining an understanding of different techniques for freezing and logistics for creation of ice molds, in general. It was determined that testing should begin with impact of ice, without introduction of composite sandwich structures. An Izod test fitting strict specimen geometries (ASTM International, 2018) was chosen to test ice properties.

Preliminary molds (shown by Figure 5) were designed in SolidWorks and printed using the HICTOP 3D printer. Dimensions for Izod test specimens were laid out in the ASTM guidelines, and part wall thickness was 1mm.

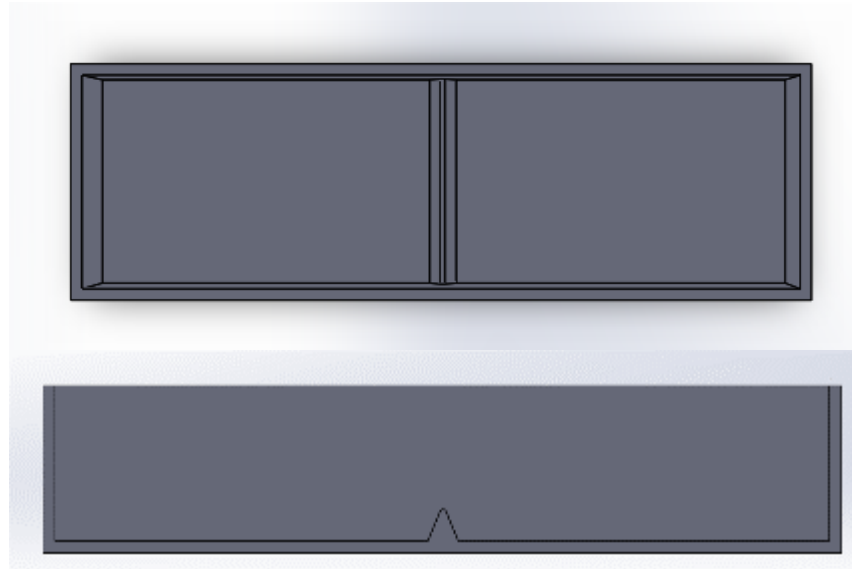

*Figure 5. Izod test specimen ice mold.*

These initial parts were printed in flexible TPU material to aid in removal of specimens. The goal was to subject ice specimens created by these molds to an Izod test on the INSTRON machine. However, several critical issues were experienced with respect to this stage of research. The ice molds were highly inconsistent and would frequently yield compromised specimens. The layer-by-layer printing method employed by the HICTOP 3D printer allowed for small grooves within molds. Ice would freeze into these grooves, making retrieval of uncompromised specimens difficult. Additionally, required geometry for an Izod test was ill-suited to fixtures in the INSTRON machine. The ice was prone to melting more quickly than tests could be performed. After several failures in testing, it was concluded that a new approach was necessary. This led to use of new equipment and materials and beginning of the second stage of research.

Secondary stage of research began with creation of the ice impactor mold. The new mold would create ice impactors that could strike specimens, rather than being struck by attachments to the INSTRON impact tester. Additionally, the HICTOP printer was changed in favor of a Stratasys Objet260. This new printer used a hard, resin cured material, but it printed as a liquid. This created molds with an exceptionally smooth inner surface, absent the grooves that caused issues in previous mold designs. Three different mold designs were tested, all of differing outside geometries, with two of the molds introducing a tapered design to aid in specimen removal. Figure 6 shows each mold design.





*Figure 6.* Left to right: Mold A, Mold B, and Mold C

Mold B (dimensions in Figure 7) was ultimately found to be the most successful iteration and was used for all subsequent testing. The mold created ice impactor specimens in full, intact states as shown in Figure 8.

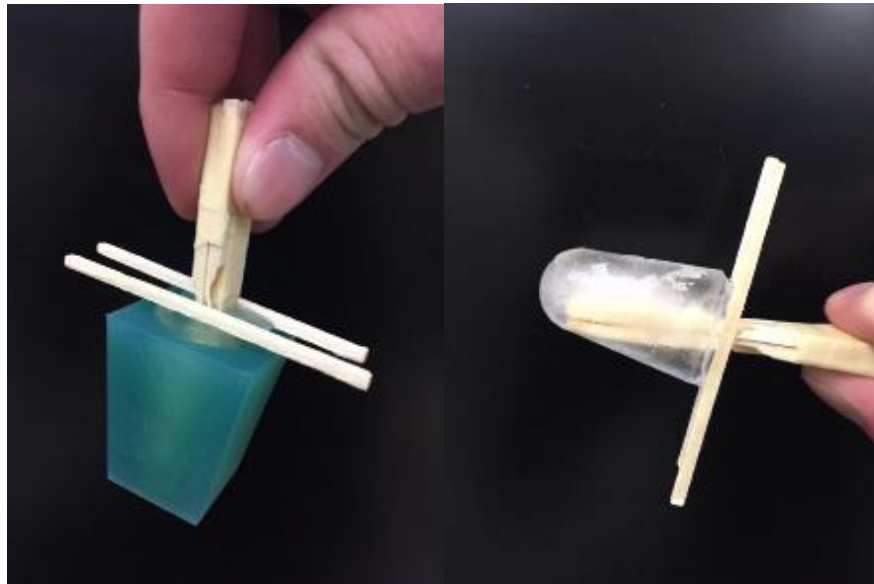

*Figure 7.* Mold B with intact ice specimen.

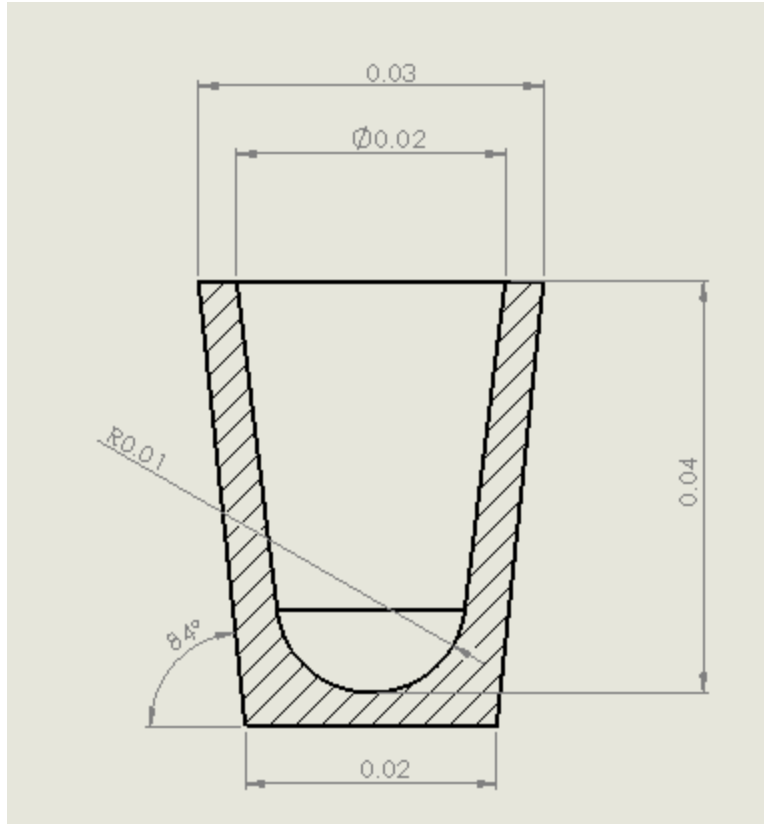

Figure 8. Mold B dimensions.

After settling on a mold design, an adapter for the INSTRON machine needed to be created. Referencing dimensions of the mold, a design for the adapter was created in SolidWorks that specifically fit to the mold (Figure 9). Then the adapter was machined (Figure 10).

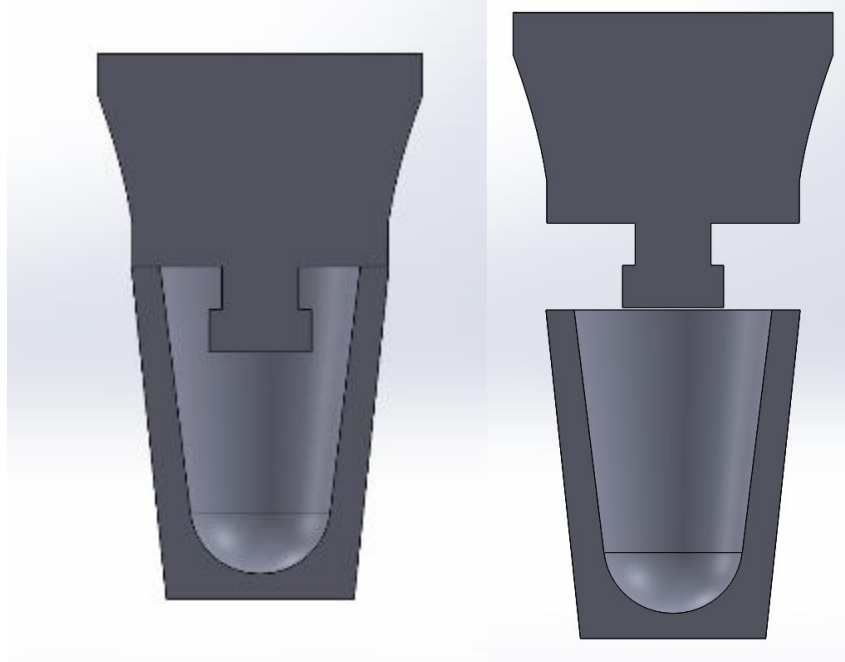
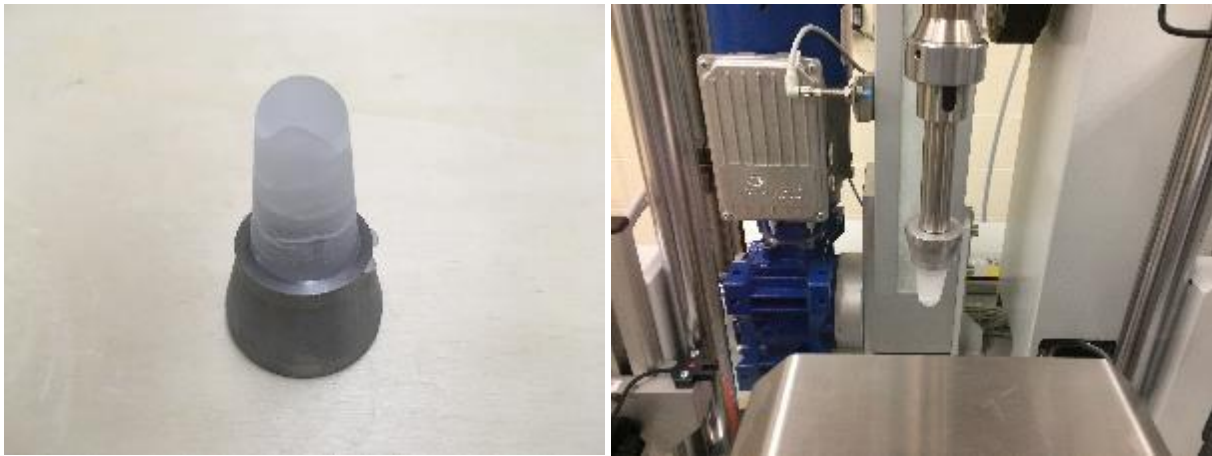

Figure 9. Adapter fit to mold.



*Figure 10.* Machined steel adapter.

The ice impactor mold/adapter design functioned appropriately, and it was tested in the INSTRON machine. Figure 11 shows the complete, functional ice impactor.



*Figure 11.* Completed ice impactor.

The completed ice impactor was tested multiple times. The first test was an impact at 10 Joules of energy, impacting on a thick, solid composite (not a sandwich structure). Figure 12 shows moment of impact for the test. There was no noticeable damage to the composite, and data was taken for force vs. time, force vs. displacement, and energy vs. time graphs, represented by Figure 13.



Figure 12. Moment of impact.

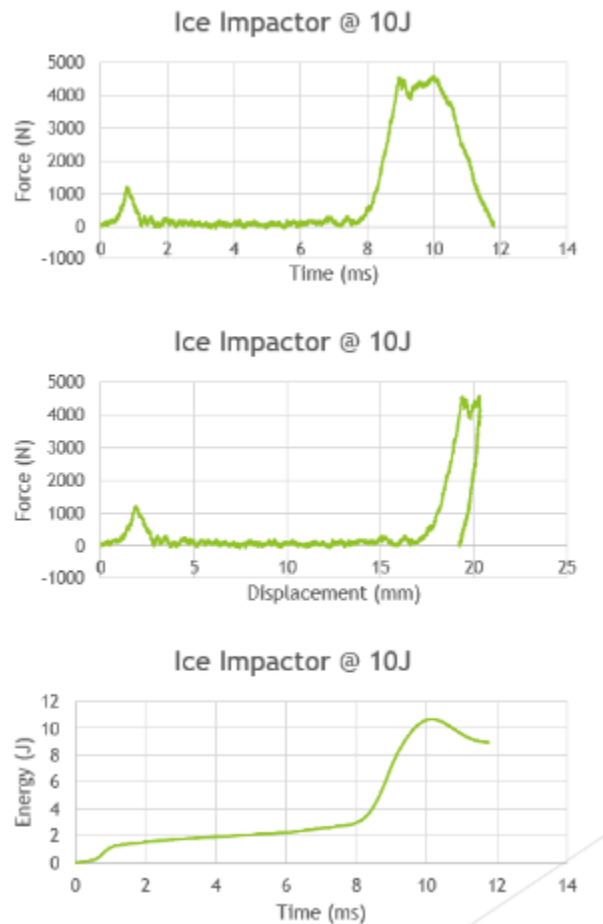

Figure 13. Ice impact data @ 10 Joules.

Data from the 10 J test is noteworthy for several reasons. First, both force graphs clearly indicate a secondary impact at roughly 8-10 milliseconds. This secondary impact was likely the adapter striking the impact site. Most likely, the ice impactor struck composite surface and shattered, but the INSTRON machine could not stop momentum before the adapter hit as well.

This is problematic because future testing relies on observation of damage done solely by ice impact. If the steel adapter impacts sandwich structure specimens, as well, results are invalidated. A second series of tests were conducted, this time at 6 J. The ice impactor, steel impact head, and bare adapter were all tested on composite sandwich structures. Data was then analyzed and compared. All test results are compared against each other in Figure 14.

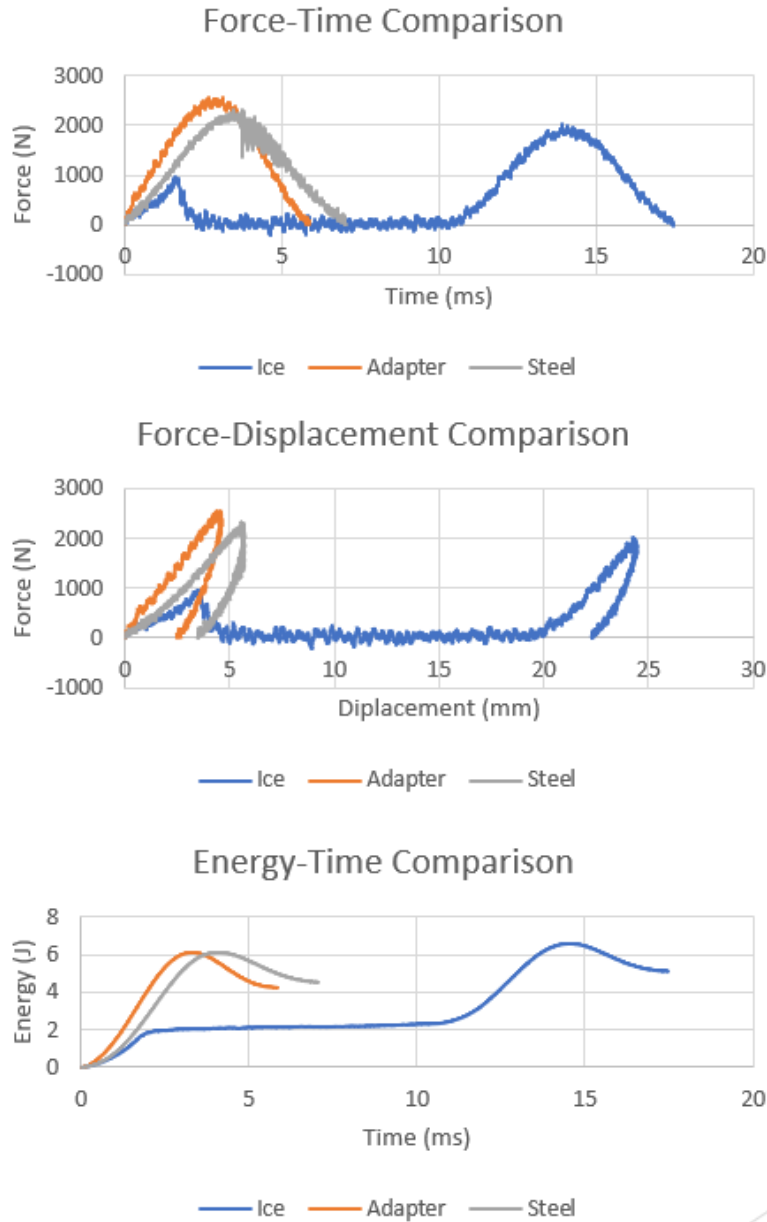

Figure 14. Impact comparison @ 6 J.

A direct comparison of these three tests reveals the extreme disparity in time duration across tests. Secondary impact for the ice impactor occurred nearly ten milliseconds later than impacts for adapter and steel tests. The adapter and steel data curves display some differences, as well. While impact energy (from energy-time comparison) is similar for both, adapter curve

demonstrates impact at a higher force than the steel impactor, as well as peaking at a slightly earlier time. Also, a small dip in the steel impactor test seems to indicate mild deformation of impact surface (the composite sandwich structure). Comparison of energy-time graphs in Figure 14 and 13 can also give a rough estimation of energy absorbed by composite sandwich structure in the 6 J test. Impact energy for ice impactor in the 6 J test is approximately 1.8 J, and 1.5 J in the 10 J test. Given that the 10 J test involved impact on a mostly rigid surface, it can be estimated that difference in impact energy values shows energy absorbed by the composite sandwich structure as roughly 0.3 J.

Despite the progress demonstrated by this test, there is one primary issue that needs to be addressed. The double impact represents a real source of error in both quantitative and qualitative analysis of impact damage done by ice impactor. Finding a solution to that problem is a key objective within the third stage of this research.

To address any double impact issues, it is necessary to understand from where the problem originates. As evidenced by results in Figure 13, the volume of ice created by previous iterations of ice mold can only absorb 1.8 J before breakage occurs. Solution to double impact problem should, therefore, involve an increase in overall volume of the mold. Thus, the mold was redesigned to yield a substantial increase in volume. Measurements were taken from the INSTRON machine test opening to establish an absolute maximum size for both adapter and ice impactor. The adapter was also redesigned accordingly, as shown in Figure 15. Preliminary mold designs can be seen by Figure 16. This mold was also to be printed in hard, cured resin by the Objet260.

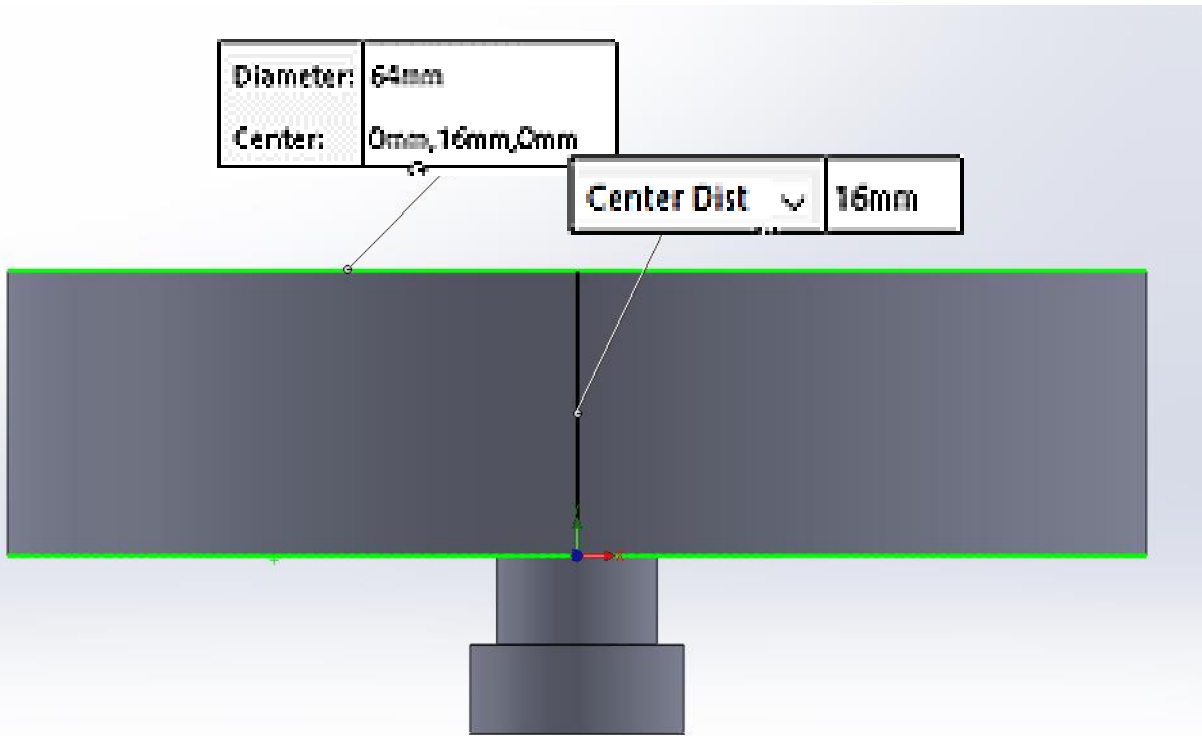
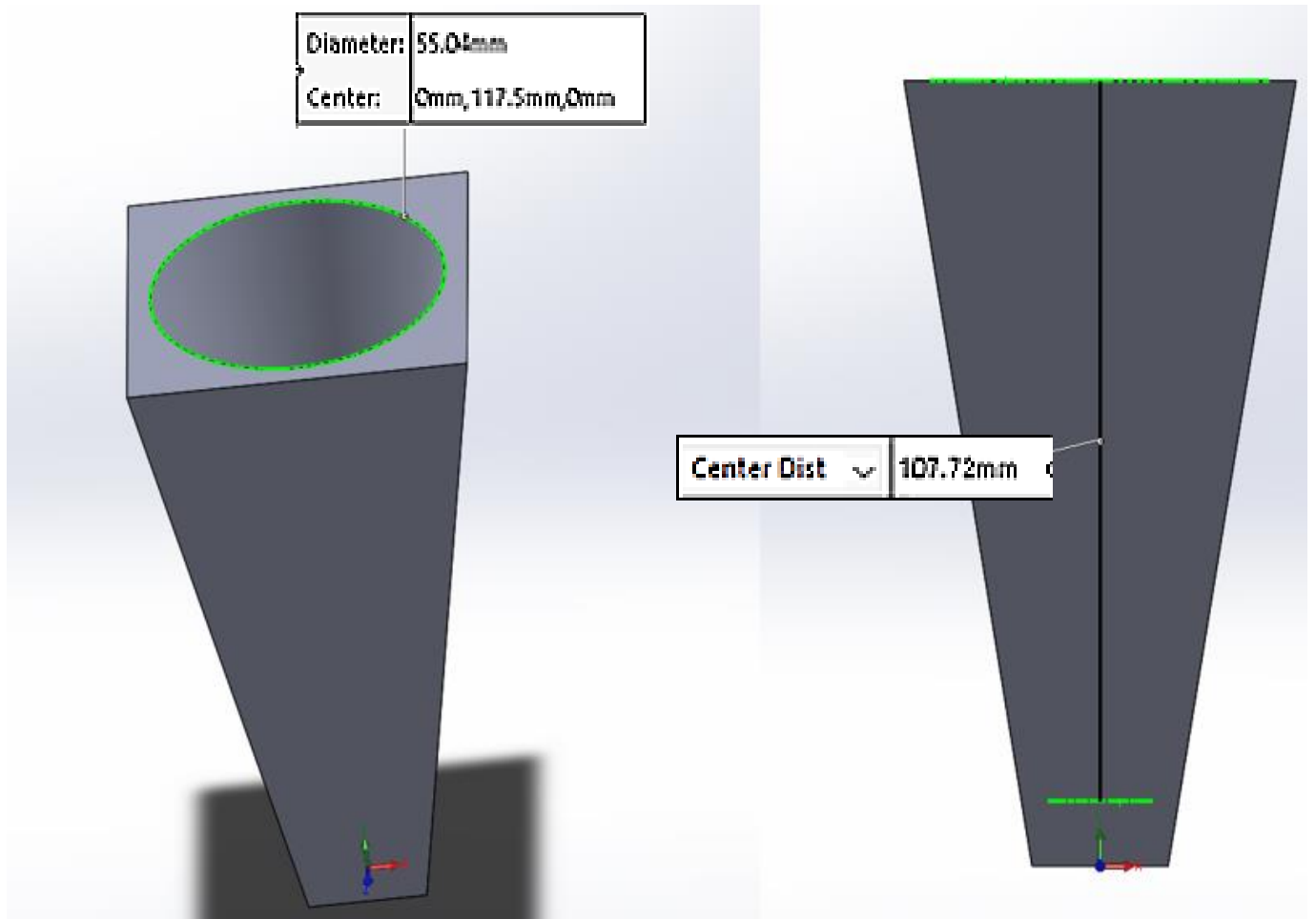

Figure 15. Redesigned steel INSTRON adapter.



*Figure 16.* Expanded ice mold design.

This mold saw many issues, and multiple iterations were tested to create a functional mold at this larger scale. The first mold was created as a scaled-up version of Mold B that was tested previously. It was found that the ice impactor was too solidly frozen into this mold and could not be removed without compromising impactor. A second, sectioned mold design was attempted, but it experienced substantial leakage issues. Both designs can be seen by Figure 17.

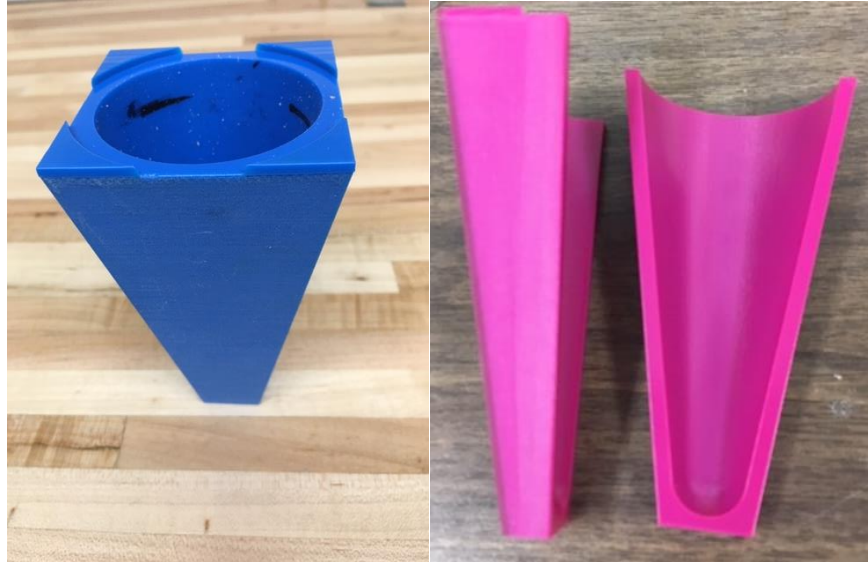

Figure 17. Expanded mold iterations. Left to right: solid piece mold, sectioned mold.

Given the relative failure of these iterations, it once again became necessary to find a new and creative solution. In this case, it was decided that a change in printing material could solve the problem. The Objet260 has a particular material option, known as Tango material. This Tango material is highly elastic and flexible, and it can be printed to specific dimensions similar to previous solid iterations of ice mold. A two-piece design was chosen for the new mold, consisting of an elastic inner lining of Tango material and a hard, outer shell of standard PLA printing plastic. Designs for the mold can be seen in Figure 18, and Figure 19 shows completed mold. Thickness of the Tango inner lining is approximately 1.5 mm.

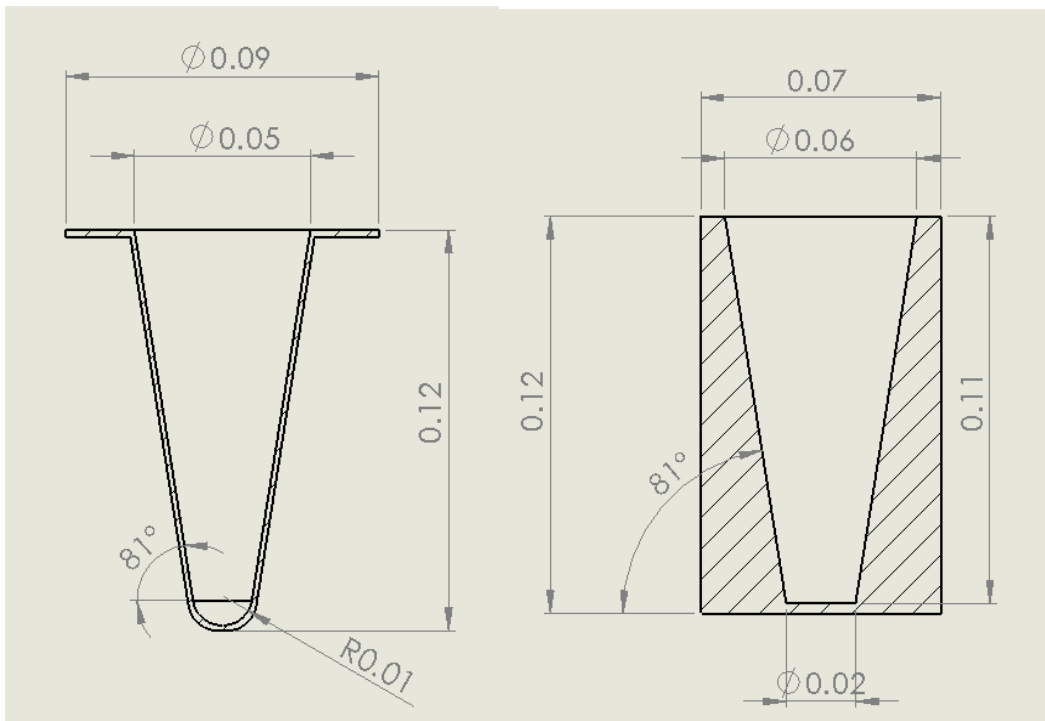

Figure 18. Two-piece mold design. Left to right: Tango inner lining, PLA outer shell.





*Figure 19.* Completed two-piece mold.

The completed mold yielded an intact ice impactor, with relatively few internal defects. It should also be noted that, during this testing process, a standard for ice impactor freezing conditions was also determined. For all future tests, freezing will occur at  $-8\text{ }^{\circ}\text{C}$  over the course of one week. Full ice impactor is shown in Figure 20.



*Figure 20.* Full ice impactor from two-piece mold.

The finalized ice impactor was then tested against solid, composite impact surface, similar to the previous 10 J test, at impact energy of 6 J. Figure 21 shows moment of impact for the 6 J test. The ice impactor was compromised, but otherwise remained whole enough to conduct a second test at 10 J. Results for both tests are shown by Figure 22.



Figure 21. Moment of impact, finalized impactor, 6 J.

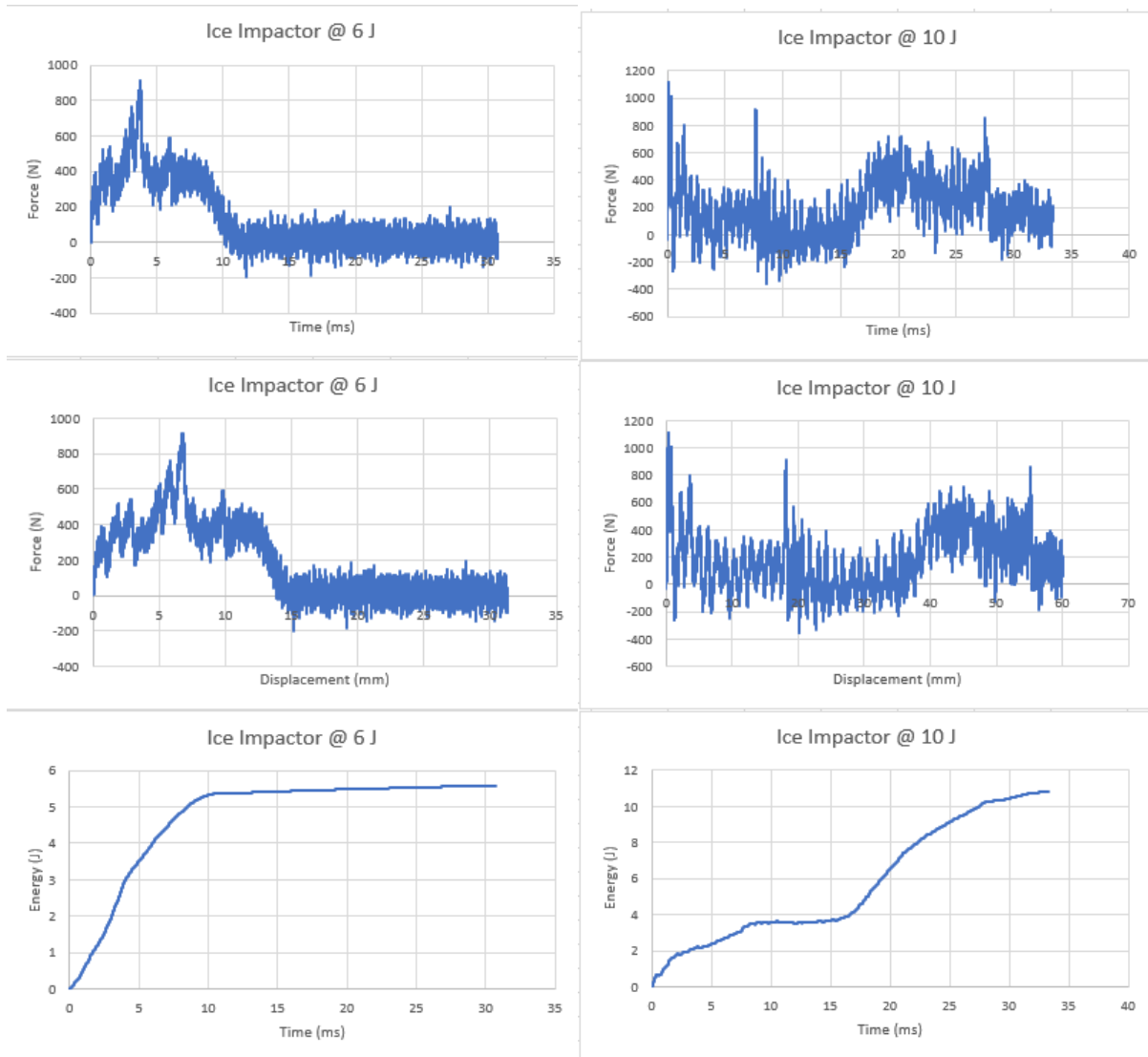

Figure 22. Finalized ice impactor results @ 6 and 10 J impacts.

As can be seen by both tests, double impact has been eliminated from the results. The energy-time graph for the 10 J test seems to show a double impact, but this is not the case. The time curve rises to a peak but does not drop from there. This is evidence that no energy rebound has occurred. Thus, the critical issue represented by double impact has been resolved, and further testing can proceed in future work.

#### 4 Conclusion

The course of this research has evolved over many trials. Many issues and failed design iterations were addressed and refined into a finalized mold/adaptor setup. The results obtained from testing on mold iterations confirm functionality and give valuable insight into possible data of future tests. Future work involves mass manufacture of the successful mold/adaptor setup, as well as formulation of a test schedule and order of uncompromised composite sandwich structure samples. Once those objectives have been completed, low-temperature testing can begin on samples, using the functional ice impactor. Data can then be analyzed, and further conclusions can be drawn.

#### 5 Acknowledgements

I would like to thank a number of individuals for their support in this research endeavor. Dr. K.T. Tan, my project supervisor, provided guidance and direction for this research, as well as necessary facilities. I would also like to thank my readers, Dr. Gregory Morscher and Dr. Reza Madad. Their comments helped me to edit and refine this report.

#### 6 References

- ASTM International. (2018). Standard test methods for determining the Izod pendulum impact resistance of plastics (ed. D256). West Conshohocken, PA: Author.
- Elamin, M., Li, B., & Tan, K. T. (2018). Impact damage of composite sandwich structures in arctic condition. *Composite Structures*, 192, 422-433.
- Prato, A., Longana, M. (2018). A novel approach for the investigation of low energy ice impacts. *International Journal of Impact Engineering*, 121, 12-19.
- <https://www.nytimes.com/interactive/2017/05/03/science/earth/arctic-shipping.html>