

1994

Controlling Inadvertent Ambiguity in the Logical Structure of Legal Drafting by means of the Prescribed Definitions of the A-Hohfeld Structural Language

Layman E. Allen

University of Michigan Law School, laymanal@umich.edu

Charles S. Saxon

Eastern Michigan University

Available at: <https://repository.law.umich.edu/articles/636>

Follow this and additional works at: <https://repository.law.umich.edu/articles>

 Part of the [Legal Writing and Research Commons](#), and the [Legislation Commons](#)

Recommended Citation

Allen, Layman E., co-author. "Controlling Inadvertent Ambiguity in the Logical Structure of Legal Drafting by means of the Prescribed Definitions of the A-Hohfeld Structural Language." C. S. Saxon, co-author. *Theoria* 9, no. 21 (1994): 135-72.

This Article is brought to you for free and open access by the Faculty Scholarship at University of Michigan Law School Scholarship Repository. It has been accepted for inclusion in Articles by an authorized administrator of University of Michigan Law School Scholarship Repository. For more information, please contact mlaw.repository@umich.edu.

CONTROLLING INADVERTENT AMBIGUITY IN THE LOGICAL STRUCTURE OF LEGAL DRAFTING BY MEANS OF THE PRESCRIBED DEFINITIONS OF THE A-HOHFELD STRUCTURAL LANGUAGE †

Layman E. ALLEN *
Charles S. SAXON **

ABSTRACT

Two principal sources of imprecision in legal drafting (vagueness and ambiguity) are identified and illustrated. Virtually all of the ambiguity imprecision encountered in legal discourse is ambiguity in the language used to express logical structure, and virtually all of the imprecision resulting is inadvertent. On the other hand, the imprecision encountered in legal writing that results from vagueness is frequently, if not most often, included there deliberately; the drafter has considered it and decided that the vague language best accomplishes the purpose at hand. This paper focuses on the use of some defined terminology for minimizing inadvertent ambiguity in the logical structure of legal discourse, where desired by the drafter. The current set of signaled structural definitions that are included in the A-Hohfeld language are first set forth and their use is illustrated in an extensive example from the treaty establishing the European Economic Community. The use of definitions in legal writing is widespread, but addressed almost exclusively to controlling the vagueness of substantive legal terms; they are seldom used for structural purposes. Furthermore, their use in American legislative drafting is unsignaled. Here, attention is devoted to the relatively-neglected domain in legal discourse of imprecisely expressed logical structure, and the remedy offered, where desired by the drafter, is a set of signaled structural definitions for use in controlling such imprecision.

Precision, Intent, and Signaling

To help drafters of legal text more effectively achieve their purposes, it is useful to focus upon concepts of precision, intent, signaling, and their opposites. Drafters may wish their text to be precise (or imprecise) in various ways, but with respect to various parts of the text they may or may not have such wishes. Absence of such wishes may be the result of deliberate consideration, or it may be that the drafter simply did not think about the matter at all for a given part of the text. But when drafters do have wishes to implement, they sometimes succeed in

expressing their desires in appropriate text. However, frequently they fail to do so adequately, either through inadvertence or lack of skill. When such failure occurs in the expression of the logical structure of legal rules, it often can be attributed to the lack of adequate consideration of alternative structural interpretations that can reasonably be given to the natural language used to express the structure. Such language depends heavily upon context to signal the appropriate structural interpretation; unsupplemented it does not have strong signaling capability for pointing to the desired interpretation in ways that are not cumbersome.

The precision of text can be analyzed in at least two principal forms: semantic precision and precision of the logical structure. This Article deals with techniques for controlling the precision of the logical structure. To the extent that precision is lacking, there is imprecision in the semantics or logical structure of legal text. These two types of imprecision in legal language are summarized in Figure 1 below. It is the imprecision in the expression of logical structure that needs attention in legal drafting. That is the part that is done relatively badly. That is the part that can be improved by the use of appropriate techniques.

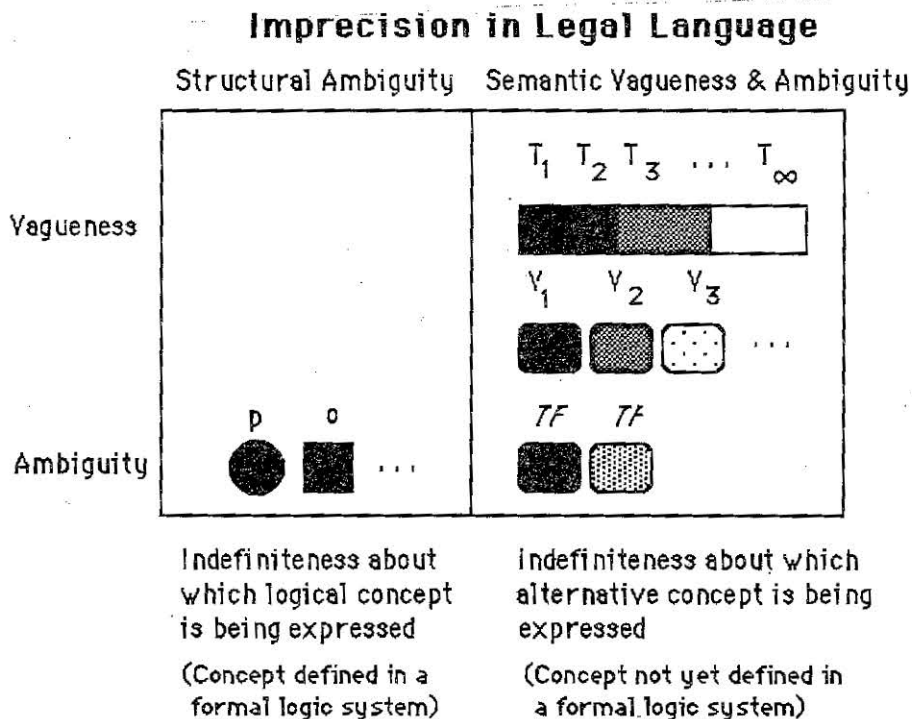

Figure 1

Structural imprecision is imprecision in the natural language used to express concepts that are precisely defined in formal systems of logic. Such imprecision is, thus, indefiniteness about what logical relationship is being expressed by a word or a phrase or their ordering. Structural imprecision differs from semantic imprecision in its degree of complexity as indicated by the number of alternative

interpretations. There is only one type of structural imprecision -namely, structural ambiguity.

Semantic imprecision, on the other hand, is of two types -semantic ambiguity and semantic vagueness. These two types of semantic imprecision tend to be at opposite ends of a continuum of the number of alternative interpretations, and they tend to shade into each other. Semantic ambiguity is imprecision with relatively few alternative interpretations of the word or phrase being considered, while semantic vagueness is imprecision with a relatively large number (even an infinite number) of alternative interpretations.

An example of a semantically vague term is "seasonably" as used throughout the American Uniform Commercial Code. It is defined in Section 1-204(3) in the following terms:

- (3) An action is taken "seasonably" when it is taken at or within the time agreed or if no time is agreed at or within a reasonable time.

So defined it refers to action occurring within some not-exactly-specified period of time. The multitude of different periods of time that have elapsed before action is taken, which may or may not qualify as acting "seasonably", are represented in Figure 1 by the shaded continuum in the upper right. That time-period (T) within which action will qualify as acting "seasonably" may be five minutes, five hours, five days, five weeks, five months, or any other number of some measure of time. As represented in Figure 1, the darker the background and the smaller the T subscript, the greater is the probability that action taken within that time-period will qualify as acting "seasonably". Arranged along a continuum, there are an infinite number of periods of time that a judge may decide to qualify as acting "seasonably". The large number of such alternative interpretations indicates that this candidate is a semantically vague phrase.

At the lower end of the semantic-imprecision continuum in the lower right of Figure 1, there is an example of a semantically ambiguous statement: "Time flies." Its first interpretation (noun-verb) is about time; its second (verb-noun), a command to do something with respect to flies. This candidate has these two, and possibly some other interpretations, but in any event a relatively few number of alternatives, and so it would be viewed as a case of semantic ambiguity.

H.L.A. Hart's classic example of "open-textured" terms in law, the word "vehicle", in the rule: "Vehicles are prohibited in the park." illustrates how semantic ambiguity shades into semantic vagueness¹ This is represented in the middle right of Figure 1. As one considers alternatives of what should qualify as a "vehicle" for purposes of being banned from the park, baby carriages and toy wagons seem to be clear instances of non-vehicles, while motorcycles, autos, and noisy internal-combustion-engine go-carts are certainly likely to be deemed vehicles for these purposes. And then there are buses, taxicabs, trucks, vans, and the list grows on and on. But the numbers of qualifying alternatives really accelerates when one begins to consider what modifications of the non-qualifying baby carriage will get it across the line to being a banned go-cart: the replacement of the handle by a steering wheel? The addition of self-propulsion by battery? Or

of a noisy internal-combustion engine? As the number of alternatives multiply, the candidate moves farther and farther away from the ambiguity end, and closer and closer to the vagueness end, of the semantic-imprecision continuum.

Thus, semantic imprecision ranges from the relatively few alternative interpretations of semantic ambiguity to the relatively many alternative interpretations of semantic vagueness. Semantic imprecision of a word or phrase is indefiniteness about precisely what the word or phrase shall be deemed to refer to.

When imprecision occurs in the semantic dimension of legal text, it seems most often to be there deliberately -at least that is our experience in nearly four decades of reading such text. Drafters use semantic imprecision to achieve a host of legitimate purposes: among others, for political compromise, to provide for the delegation of decision-making power from one legal institution to another, and to facilitate adaptation of the legal system to changing circumstances through time by means of court and administrative decisions without having to return to cumbersome legislative processes for such change.

Imprecision in the expression of the logical structure of legal rules, on the other hand, seems much less deliberate. In our experience, such structural imprecision appears to be inadvertent much more often. Also, structural imprecision does not involve vagueness with its relatively large number of interpretations of what the individual word or phrase refers to; it involves only ambiguity with its relatively few alternative interpretations. However, although the number of alternative interpretations of individual words or phrases that express logical structure may be few, in combination with other structurally-ambiguous terms the number of alternative interpretations of a single legal rule or small set of rules can quickly mount to formidable numbers².

For an example of imprecision in the expression of logical structure, consider the following hypothetical provision in a set of Corporate By-Laws.

A member of the Board of Directors shall not vote for the election of officers, unless that member is present at the meeting of the Board for the election of officers.

How should the word "unless" in this provision be interpreted? Which of the following alternatives, A or B, is the more appropriate interpretation?

- A) IF a member of the Board of Directors is not present at the meeting of the Board for the election of officers,
THEN that member shall not vote for the election of officers.
- B) IF a member of the Board of Directors is not present at the meeting of the Board for the election of officers,
THEN that member shall not vote for the election of officers, AND
IF a member of the Board of Directors is present at the meeting of the Board for the election of officers,
THEN that member shall vote for the election of officers.

How should the words "shall not" be interpreted in the sentence:

That member shall not vote for the election of officers.

Which of the following alternatives, A through D, is the most appropriate interpretation?

- A) That member **MUST NOT** vote for the election of officers.
- B) That member has **POWER** to vote for the election of officers, but **MUST NOT** engage in action that would exercise such **POWER**.
- C) That member lacks **POWER** to vote for the election of officers and **MAY BUT NEED NOT** engage in action that would exercise such **POWER**.
- D) That member lacks **POWER** to vote for the election of officers and **MUST NOT** engage in action that would exercise such **POWER**.

It is the controlling of -not necessarily the elimination of- such structural ambiguity that this Article concerned. It is only the elimination of the inadvertence in the use of such ambiguity that is being urged. The tools for facilitating the control of inadvertent structural ambiguity are the 35 defined structural terms set forth in the next section. As with any set of definitions, more may be added as it is found useful to do so.

Contextual Definitions of A-Hohfeld Structural Terms

Defined structural terms, whenever they are used or defined, are signaled by expressing them in capital letters. For example:

The statement:

"x **MUST** y"

is by stipulated definition equivalent in meaning to the statement:

"x is legally obligated to do y".

The preceding sentence is a contextual definition of the word "**MUST**". Such contextual definitions will be presented here in the following abbreviated form:

"x **MUST** y" means

"x is legally obligated to do y".

There are 35 defined terms in the A-Hohfeld³ (short for Allen-Hohfeld) language. These are summarized in Figure 2 below, which shows the relationships between these defined terms. Their contextual definitions are presented in alphabetic order following Figure 2.

THE 35 DEFINED TERMS OF THE A-HOHFELD LANGUAGE

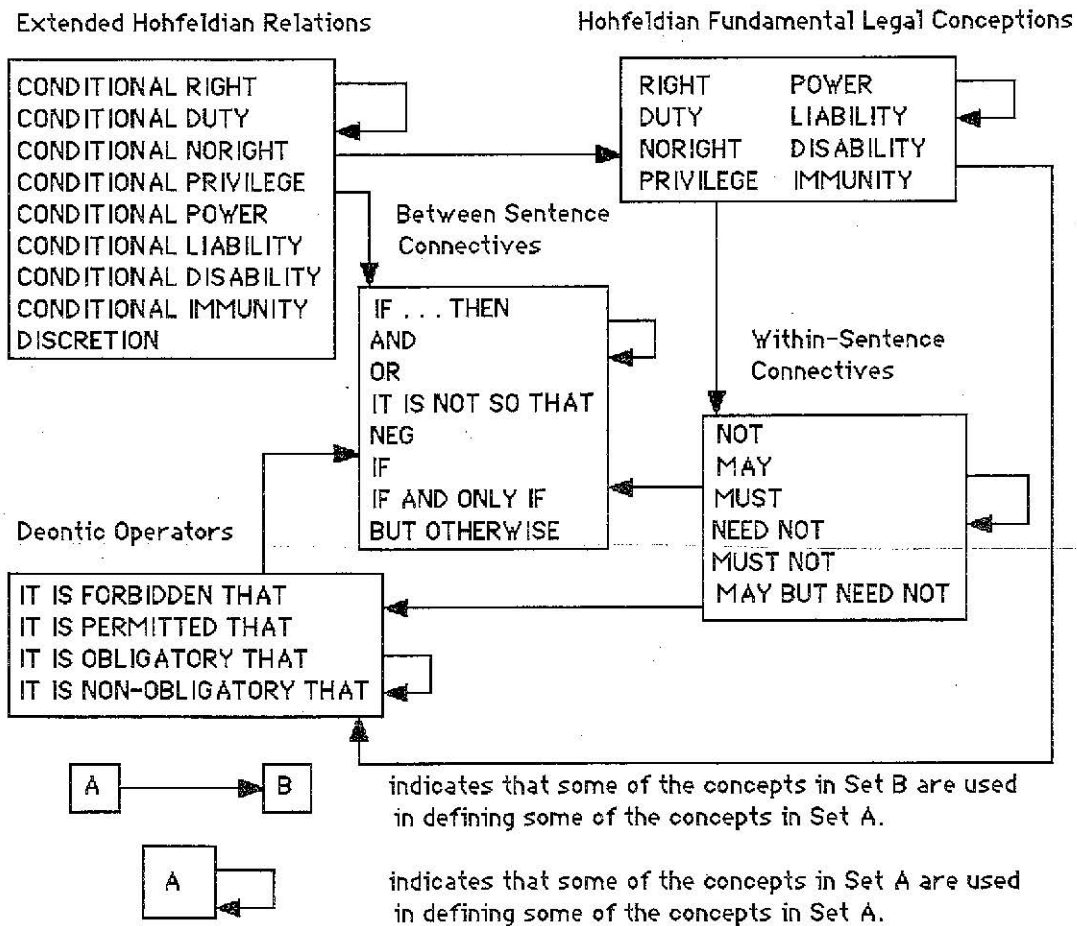

Figure 2

The current 35 structural definitions in the A-Hohfeld language are organized into the five categories below.

- 8 Between-Sentence Connectives
- 9 Extended Hohfeldian Relations
- 8 Hohfeldian Fundamental Legal Conceptions
- 4 Deontic Operators
- 6 Within-Sentence Connectives

The relationships between the definitions in each of the categories is indicated by the arrows between the various categories in Figure 2. Some of the definitions in some of the categories are used in defining the terms in other categories. Some of the definitions in one of the categories are used in each of the other categories. For example, IF...THEN and AND in the between-sentence connectives are used in defining CONDITIONAL RIGHT in the extended Hohfeldian relations, in defining DUTY in the Hohfeldian fundamental legal conceptions, in defining IT IS FORBIDDEN THAT in the Deontic operations, and in defining MUST in the within-sentence connectives.

In each of the five categories some of the definitions are defined in terms of other definitions in that same category. For example, DUTY in the Hohfeldian fundamental legal conceptions is defined in terms of RIGHT in that same category. This self-referentiality of the categories is indicated in Figure 2 by the arrow "feeding back" into the category.

THE 35 DEFINED STRUCTURAL TERMS (In alphabetic order)

"a **AND** b." means'

"The state of affairs described by sentence-a is so, and
the state of affairs described by sentence-b is so."

"p1 has **CONDITIONAL DISABILITY** to create legal relation-1r." means"

"p1 has **POWER** to create legal relation-1r, **AND**
there is an event-e1 such that

1. it is naturally possible for event-e1 to occur, **AND**
2. **IF** event-e1 occurs, **THEN** condition-v is fulfilled, **AND**
3. **IF** condition-v is fulfilled, **THEN** p1's **DISABILITY** to create legal relation-k is created."

"p1 has a **CONDITIONAL DUTY** that p2 do b." means"

"p2 has a **CONDITIONAL RIGHT** that p1 do b."

"Legal relation-1r has **CONDITIONAL IMMUNITY** of being created by p1." means

"p1 has **CONDITIONAL DISABILITY** to create legal relation-1r."

"Legal relation-1r has **CONDITIONAL LIABILITY** of being created by p1." means

"p1 has **CONDITIONAL POWER** to create legal relation-1r."

"p1 has a **CONDITIONAL NORIGHT** that p2 do b." means

"p1 has a **RIGHT** that p2 do b, **AND**
there is an event-e1 such that

1. it is naturally possible for event-e1 to occur, **AND**
2. **IF** event-e1 occurs, **THEN** condition-v is fulfilled, **AND**
3. **IF** condition-v is fulfilled, **THEN** p1's **NORIGHT** that p2 do b is created."

"p1 has **CONDITIONAL POWER** to create legal relation-1r." means

"p1 lacks **POWER** to create legal relation-1r, **AND**
there is an event-e1 such that

1. it is naturally possible for event-e1 to occur, **AND**
2. **IF** event-e1 occurs, **THEN** condition-v is fulfilled, **AND**
3. **IF** condition-v is fulfilled, **THEN** p1's **POWER** to create legal relation-1r is created "

"p1 has a **CONDITIONAL PRIVILEGE** that p2 do b." means

"p2 has a **CONDITIONAL NORIGHT** that p1 **NOT** do b."

"p1 has a **CONDITIONAL RIGHT** that p2 do b." means

"p1 has a **NORIGHT** that p2 do b, **AND**
there is an event-e1 such that

1. it is naturally possible for event-e1 to occur, **AND**
2. **IF** event-e1 occurs, **THEN** condition-v is fulfilled, **AND**

3. IF condition-v is fulfilled, THEN p1 's RIGHT that p2 do b is created."

"p1 has **DISABILITY** to create legal relation-1r." means

"p1 lacks **PÖWER** to create legal relation-1r."

"p1 has **DISCRETION** with respect to p2 as to whether or not to do b." means

"p1 has a **PRIVILEGE** with respect to p2 to do b, AND

p1 has a **PRIVILEGE** with respect to p2 NOT to do b."

"p1 has a **DUTY** to p2 to do b." means

"p2 has a **RIGHT** that p1 do b." which, in turn, means

"IT IS **OBLIGATORY THAT** p1 do b for p2." which, in turn, means

"IF 1. IT IS NOT SO THAT p1 does b,

THEN 2. p1 has violated p2's **RIGHT** that p1 do b, AND

3. the legal system will provide a remedy to p2 with respect to p1."

"**IF a THEN b.**" means

"1. If the state of affairs described by sentence-n is so then the state of affairs described by sentence-b is so, and

2. if the state of affairs described by sentence-a is not so, then nothing is being said about whether or not the state of affairs described by sentence-b is so."

"**IF a THEN b BUT OTHERWISE c.**" means

"IF a THEN b, AND IF NEG a THEN c."

'b **IF AND ONLY IF a.**" means

"IF a THEN b, AND IF NEG a THEN NEG b."

"b **IF a.**" means

"IF a THEN b."

"Legal relation-1r has **IMMUNITY** of being created by p1." means

"p1 lacks **POWER** to create legal relation-1r."

"**IT IS FORBIDDEN THAT a.**" means

"IF 1. the state of affairs described by sentence-a is NOT so,

THEN 2. there is a violation, AND

3. the legal system will provide a remedy with respect to the violator."

"**IT IS NON-OBLIGATORY THAT a.**" means

"IT IS NOT SO THAT IT IS **OBLIGATORY THAT a.**" which, in turn means

"IT IS NOT SO THAT

IT IS **FORBIDDEN THAT NEG a.**" which, in turn, means

"IT IS NOT SO THAT

IF 1. the state of affairs described by sentence-a is NOT so,

THEN 2. there is a violation, AND

3. the legal system will provide a remedy with respect to the violator."

"**IT IS NOT SO THAT a.**" means

"It is not so that the state of affairs described by sentence-a is so."

"**IT IS OBLIGATORY THAT a.**" means

"**IT IS FORBIDDEN THAT NEG a.**" which, in turn, means

IF 1. the state of affairs described by sentence-a is NOT so,
THEN 2. there is a violation, AND
3. the legal system will provide a remedy with respect to the violator."

"**IT IS PERMITTED THAT a.**" means

"**IT IS NOT SO THAT IT IS FORBIDDEN THAT a.**" which, in turn, means

"**IT IS NOT SO THAT**

IF 1. the state of affairs described by sentence-a is NOT so,
THEN 2. there is a violation, AND
3. the legal system will provide a remedy with respect to the violator."

"Legal relation-1r has **LIABILITY** of being created by p1." means

"p1 has **POWER** to create legal relation-1r."

"a1 **MAY** a2." means

"**IT IS PERMITTED THAT a1 a2.**" (where a1 concatenated with a2 is a sentence) which, in turn, means

"**IT IS NOT SO THAT**

IF 1. the state of affairs described by sentence-a1-a2 is NOT so,
THEN 2. there is a violation, AND
3. the legal system will provide a remedy with respect to the violator."

"a1 **MAY BUT NEED NOT** a2." means

"a1 **MAY** a2, AND a1 **NEED NOT** a2."

"a1 **MUST** a2." means

"**IT IS OBLIGATORY THAT a1 a2.**" which, in turn, means

IF 1. the state of affairs described by sentence-a1-a2 is NOT so,
THEN 2. there is a violation, AND
3. the legal system will provide a remedy with respect to the violator."

"a1 **MUST NOT** a2." means

"**IT IS OBLIGATORY THAT a1 NOT a2.**" which, in turn, means

IF 1. the state of affairs described by sentence-a1-NOT-a2 is NOT so,
THEN 2. there is a violation, AND
3. the legal system will provide a remedy with respect to the violator."

"a1 **NEED NOT** a2." means

"**IT IS PERMITTED THAT a1 NOT a2.**"

"**NEG a.**" means

"**IT IS NOT SO THAT a.**"

"p1 has a **NORIGHT** that p2 do b." means

"IT IS NOT SO THAT p1 has a **RIGHT** that p2 do b." which, in turn, means

"IT IS NOT SO THAT IT IS **OBLIGATORY THAT** p2 do b for p1."

which, in turn, means

"IT IS NOT SO THAT

IF 1. IT IS NOT SO THAT p2 does b,

THEN 2. p2 has violated p1's **RIGHT** that p2 do b, AND

3. the legal system will provide a remedy to p1 with respect to p2."

"a1 is **NOT** a2." means

"IT IS NOT SO THAT the state of affairs described by sentence-(a1 is a2) is so."

AND also notice that

"a1 **NOT** a2." implies that

"IT IS NOT SO THAT the state of affairs described by sentence-(a1 a2) is so."

BUT IT IS NOT SO THAT

"a1 **NOT** a2." is always implied by

"IT IS NOT SO THAT the state of affairs described by sentence-(a1 a2) is so."

For example,

The sentence, "Jones **MUST NOT** fail to provide for the education of his minor children" implies the sentence,

"IT IS NOT SO THAT Jones **MUST** fail to provide for the education of his minor children"

And an example in which the first is not implied by the second is the following:

IT IS NOT SO THAT the sentence, "Jones **MUST NOT** provide for the education of his 21-year old children" is implied by the sentence,

"IT IS NOT SO THAT Jones **MUST** provide for the education of his 21-year old children".

"a **OR** b." means

"The state of affairs described by sentence-a is so, or the state of affairs described by sentence-b is so, or both are so."

"p1 has a **PRIVILEGE** with respect to p2 to do b." means

"IT IS NOT SO THAT p2 has a **RIGHT** that p1 **NOT** do b." which, in turn, means

"IT IS NOT SO THAT IT IS **OBLIGATORY THAT** p1 **NOT** do b for p2."

which, in turn, means

"IT IS NOT SO THAT

IF 1. p1 does b,

THEN 2. p1 has violated p2's **RIGHT** that p1 **NOT** do b, AND

3. the legal system will provide a remedy to p2 with respect to p1."

"p1 has **POWER** to create legal relation-1r." means

"Legal relation-1r is **NOT** so, AND

it is naturally possible for p1 to do a1, AND

IF p1 does a1 THEN legal relation-1r is created."

"p1 has a **RIGHT** that p2 do b." means

"IT IS **OBLIGATORY THAT** p2 do b for p1." which, in turn, means

"IF 1. IT IS NOT SO THAT p2 does b,

- THEN
2. p2 has violated p1's RIGHT that p2 do b, AND
 3. the legal system will provide a remedy to p1 with respect to p2."

With these 35 defined terms of the A-Hohfeld language available, we now turn to illustration of their use in controlling the structural ambiguity of legal rules. It deserves repeated emphasis that what is being urged here is the control of structural ambiguity, not its elimination. It is only the structural ambiguities that occur as a result of inadvertence for which the question of elimination is raised. And even then, it is only a question being raised. Not all of them should go. But it is a matter that should be decided -not just continued because of inadvertence. The expression of the logical structure of one of the important provisions of the Treaty establishing the European Economic Community will be examined in detail and its structural ambiguities and alternative structural interpretations discussed. Through this examination of how it has been drafted, we will approach how it might alternatively be expressed. In short, we deal with the problem expressing logical structure in legal drafting by looking at the other side of the same coin -the problem of interpreting the logical structure of legal text.

Article 235 of the Treaty Establishing the European Economic Community

Proceeding to a consideration of the logical structure of the present language of Article 35 will illustrate the usefulness of the A-Hohfeld language for controlling the precision of the expression of such structure. It will also illustrate the process of analyzing present drafts of documents and their possible re-drafting⁴. First, the present text itself.

Article 235 Present Version

If action by the Community should prove necessary to attain, in the course of the operation of the common market, one of the objectives of the Community and this Treaty has not provided the necessary powers, the Council shall, acting unanimously on a proposal from the Commission and after consulting the European Parliament, take the appropriate measures.

After marking its constituent sentences, the between-sentence structural language stands out clearly.

Article 235 Marked Version

If [a: action by the Community should prove necessary to attain, in the course of the operation of the common market, one of the objectives of the Community] and [b: this Treaty has not provided the necessary powers], [c: the Council shall, acting unanimously on a proposal from the Commission and after consulting the European Parliament, take the appropriate measures].

Article 235 Between-Sentence Structure

If a and b, c.

Article 235 Four Ambiguities

There are at least four structural ambiguities in this deceptively simple overall sentence. One of them is in the expression of the between-sentence structure relating sentence-a and sentence-b to sentence-c. The natural language used to express a conditional relationship is ambiguous about whether it should be interpreted as expressing a single conditional relationship or a pair or such conditional relationships. (This is, perhaps, the most pervasive type of structural ambiguity in all of legal discourse in natural language -the single-double conditional ambiguity.) The other three structural ambiguities in Article 235 occur in the within-sentence structure of sentence-c. These four ambiguities will be described in the form of four questions (Q1, Q2, Q3, and Q4) and their answers, which suggest some of the alternative interpretations of the indicated text. It will be helpful to put these four questions in context with each other and the original text, and also in the form of a simplified structural diagram.

Article 235 Structural Questions

<p>(*If*) [a: action by the Community should prove necessary to attain, in the course of the operation of the common market, one of the objectives of the Community] and [b: this Treaty has not provided the necessary powers], [c: the Council (*shall*), acting unanimously (*on a proposal from the Commission and after consulting the European Parliament*), take the appropriate measures'].</p>	<p>Q1</p> <p>Q3 Q4</p> <p>Q2</p>
---------------------------------------------------------------------------------------------------------------------------------------------------------------------------------------------------------------------------------------------------------------------------------------------------------------------------------------------------------------------------------------------------------	----------------------------------

The questions are about the text enclosed in (* *). Thus, Q1 is about the interpretation of "If", Q3 and Q4 are about the interpretation of "shall", and Q2 is about the interpretation of the order of the occurrence of "on a proposal from the Commission and after consulting the European Parliament" in sentence-c.

The A-Hohfeld structural definitions are used in the expression of the questions about the structural interpretation of Article 235, as well as in the alternative answers, which constitute alternative interpretations of the part of Article 235 being dealt with in each question. Use of the defined structural language permits precise expression of both the questions and the alternative interpretations.

Question Q1. Interpretation of "IF"

Consider the interpretation of the word "If" in the following statement:

If
 action by the Community should prove necessary to attain, in the course of the operation of the common market, one of the objectives of the Community and

CONTROLLING INADVERTENT AMBIGUITY IN LEGAL DRAFTING

this Treaty has not provided the necessary powers, the Council shall, acting unanimously on a proposal from the Commission and after consulting the European Parliament, take the appropriate measures.

Hereafter, for purposes of this question, please focus on this statement in its following abbreviated form:

If
action by the Community should prove necessary to attain ... and this Treaty has not provided the necessary powers, the Council shall ... take the appropriate measures.

The statement clearly asserts at least the following conditional statement:

IF action by the Community should prove necessary to attain ..., AND
 this Treaty has not provided the necessary powers,
THEN the Council shall ... take the appropriate measures.

In the most appropriate interpretation of the word "If", which of the following lettered alternatives, in addition to the conditional statement above, should the specified statement be interpreted as asserting:

A).

(Just a period and nothing more. The overall statement does not assert anything more than the conditional statement above.)

B),

BUT OTHERWISE, something more is being stated when either one of the conditions in the antecedent of the conditional statement above is not satisfied.

Question Q2. Interpretation of Imbedded Conditions

Consider the interpretation of the following three imbedded conditions:

- acting unanimously
- on a proposal from the Commission
- after consulting the European Parliament

in the statement:

the Council shall, acting unanimously on a proposal from the Commission and after consulting the European Parliament, take the appropriate measures.

The statement clearly asserts at least the following conditional statement:

IF the Council is acting unanimously on such action, AND
 a proposal for such action has been received from the Commission,
 AND
 the Council has consulted the European Parliament on such action,
THEN the Council shall take the appropriate measures

In the most appropriate interpretation of the relationship of the three imbedded conditions to the result that the Council shall take appropriate measures, which of the following lettered alternatives, in addition to the conditional statement above, should the specified statement be interpreted as asserting:

A).

(Just a period and nothing more. The overall statement does not assert anything more than the conditional statement above.)

B),

BUT OTHERWISE, something more is being stated when at least one of the three conditions in the antecedent of the conditional statement above is not satisfied.

Question Q3. Interpretation of "shall"

Consider the interpretation of the word "shall" in the following statement:

... the Council shall, ... , take the appropriate measures

In the most appropriate interpretation of the word "shall", which of the following lettered alternatives should the specified statement be interpreted as asserting

A) the Council MUST take the appropriate measures

B) the Council (1) has POWER to take the appropriate measures and (2) MUST exercise it

C) the Council (1) has POWER to take the appropriate measures and (2) MAY BUT NEED NOT exercise it

Question Q4. Interpretation of the Negative of "shall"

There are two possible negatives of "... shall ..." -namely:

(1) it is not so that ... shall ...

and

(2) ... shall not ...

So, consider the interpretation of the words "it is not so that ... shall" in the following statement:

it is not so that the Council shall take the appropriate measures

and consider the interpretation of the words "shall not" in the following statement:

the Council shall not take the appropriate measures

Choose which of the above two statements is most appropriately regarded in this context as the negative of the positive statement

the Council shall take the appropriate measures

and then specify in the most appropriate interpretation of the words "it is not so that ... shall" and the words "shall not", which of the following lettered alternatives the negative of this positive statement should be interpreted as asserting:

- A) the Council MAY BUT NEED NOT take the appropriate measures
- B) the Council MUST NOT take the appropriate measures
- C) the Council (1) lacks POWER to take the appropriate measures and
(2) MAY BUT NEED NOT engage in action that would exercise such POWER
- D) the Council (1) lacks POWER to take the appropriate measures and
(2) MUST NOT engage in action that would exercise such POWER
- E) the Council (1) has POWER to take the appropriate measures but
(2) MUST NOT exercise it
- F) the Council (1) has POWER to take the appropriate measures and
(2) MAY BUT NEED NOT exercise it

Article 235 Number of Alternative Interpretations

In summary, there are 2 possible answers to Q1 (A or B), 2 possible answers to Q2 (A or B), 3 possible answers to Q3 (A, B, or C), and 6 possible answers to Q4 (A, B, C, D, E, or F). Thus, the answers to Q1 and Q2 give rise to the following $2 \times 2 = 4$ alternative interpretations:

	Q1	Q2	Q3	Q4
Interpretation	A	A
Interpretation	A	B
Interpretation	B	A
Interpretation	B	B

Article 235 Dependence of Answers

If the answers to each question were independent of the answers to the other questions, there would be a total of $2 \times 3 \times 6 \times 2 = 72$ alternative structural interpretations of Article 235. However, they are not all independent of each other. For example, if the answers to Q1 and Q2 are both A (to the effect that both the "If" and the imbedded conditions are appropriately interpreted as expressing only single conditionals, rather than as expressing a pair of conditionals), the ambiguity of the negation of "shall" does not even arise; Q4 does not even get asked. Because of this dependence of the answers that will be available for Q4 upon the answers given to Q1, Q2, and Q3, the total number of alternative interpretations is reduced to 30. This pattern of dependence is summarized in the diagram set forth in Figure 3.

THE 30 DIFFERENT STRUCTURAL INTERPRETATIONS OF SECTION 235

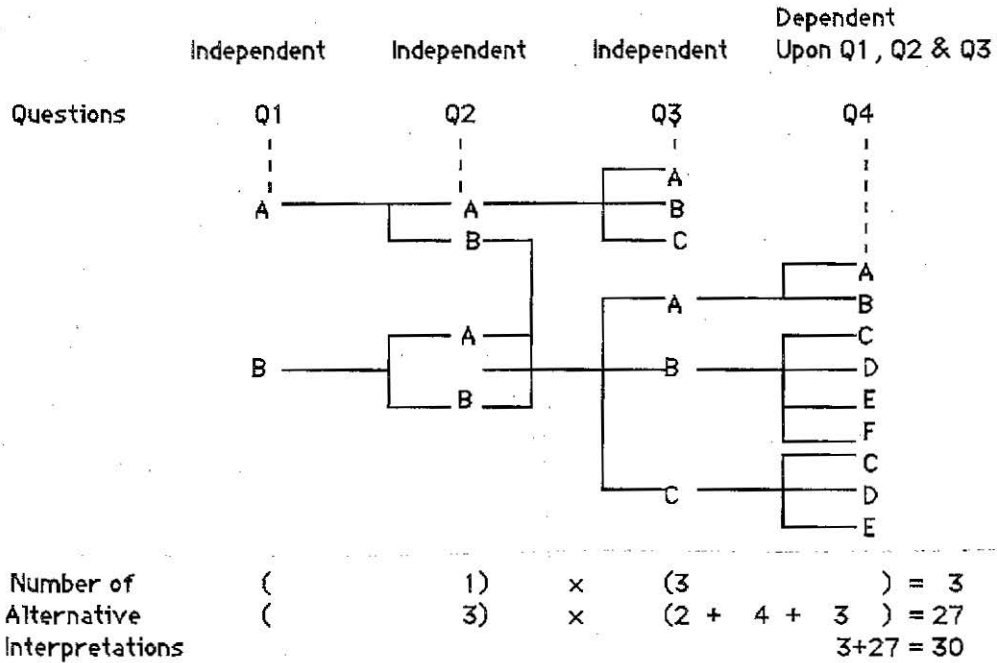

Figure 3

There are 30 different "pathways" through the diagram in Figure 3, each with a unique 4-letter name. Each pathway represents a different structural interpretation with the same name. The 4-Letter Names of Each the 30 Structural Interpretations is given below.

#	Names	#	Names	#	Names	#	Names	#	Names
1	AAA_	7	ABBD	13	BAAA	19	BACC	25	BBBD
2	AAB_	8	ABBE	14	BAAB	20	BACD	26	BBBE
3	AAC_	9	ABBF	15	BABC	21	BACE	27	BBBF
4	ABAA	10	ABCC	16	BABD	22	BBAA	28	BBCC
5	ABAB	11	ABCD	17	BABE	23	BBAB	29	BBCD
6	ABBC	12	ABCE	18	BABF	24	BBBC	30	BBCE
Q	1234		1234		1234		1234		1234

Article 235 Diagram of Four Questions and Structure

Returning now to the four questions about the logical structure of Article 235, the relationship of these four questions to that structure can be summarized in a diagram, where:

IF a AND b THEN c
BUT OTHERWISE d.

is represented by:

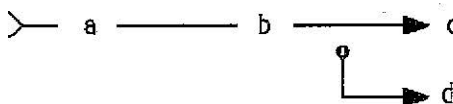

Then, a structural diagram representing the four structural questions of Article 235 is shown in Figure 4.

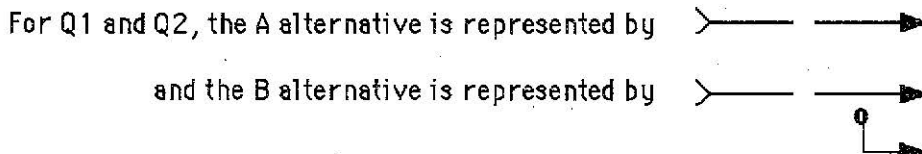
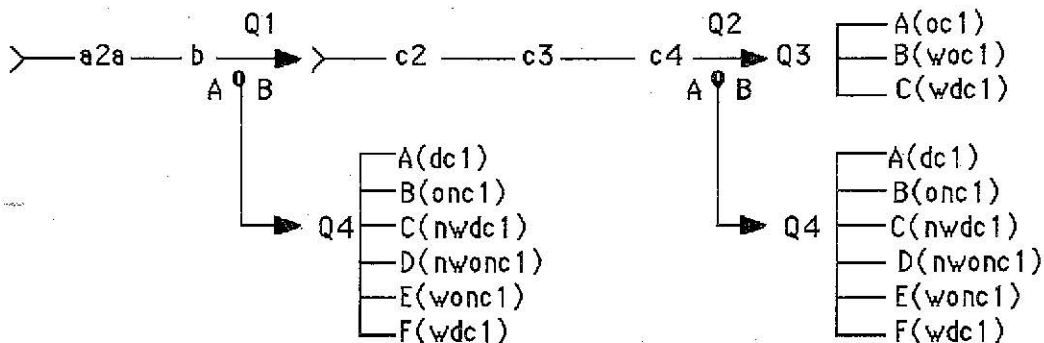

Figure 4

For Q3, the A, B, and C alternatives are represented by oc1, woc1, and wdc1, respectively. For Q4, the A, B, C, D, E, and F alternatives are represented by dc1, onc1, nwdc1, nwonc1, wonc1, and wdc1, respectively. Notice that the dependence relationship of the answers available for Q4 upon the answers given to Q1, Q2, and Q3, which is shown in Figure 3, is not captured in this structural diagram of the four questions. The structural diagram shows the relationship of questions and their alternative answers to the structure of Article 235, but not the relationship of the answers to each other.

Article 235 Answers Determine Structural Interpretations

The answers that an interpreter of Article 235 gives to the four questions will determine that interpreter's structural interpretation of Article 235. For example, the answers B, B, C, and D, respectively to Q1, Q2, Q3, and Q4 will determine the BBCD interpretation below.

Clear Normalized Version of Interpretation BBCD

IF

1. action by the Community has been proved necessary to attain, in the course of the operation of the common market, one of the objectives of the Community, AND
2. this Treaty has not provided the necessary powers, AND
3. the Council has received a proposal for such action from the Commission, AND

4. the Council is acting unanimously on the proposal for such action, AND
 5. the Council has consulted the European Parliament on such action,
- THEN
6. the Council (1) has POWER to take the appropriate measures and (2) MAY, BUT NEED NOT exercise it,
- BUT OTHERWISE,
7. the Council (1) lacks such POWER and (2) MUST NOT engage in action that would exercise such POWER.

Clear Arrow Diagram of Interpretation BBCD

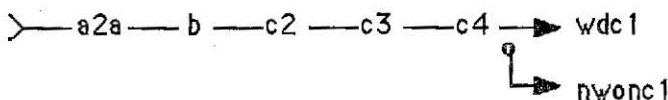

We will return to further consideration of how the answers to the four questions determine structural interpretations after some detailed consideration and illustration of how structural ambiguity can be controlled at various levels of ambiguity.

Article 235 Alternative Drafts of Alternative Combinations of Ambiguities at Various Levels Or Ambiguity

We turn now to consideration of the alternative drafts of Alternative combinations of ambiguities at various levels of ambiguity summarized in Figure 5. The contents of Figure 5 will become clear as the discussion about controlling structural ambiguity at various levels of ambiguity proceeds. Figure 5 is intended as a guide to the content of that discussion.

DRAFTS OF COMBINATIONS OF AMBIGUITIES

Ambiguities	Combinations	Drafts					
Level 4	Q1-Q2-Q3-Q4	----					
Level 3	Q2-Q3-Q4	A---	B---				
	Q1-Q3-Q4	-A--	-B--				
Level 2	Q3-Q4	AA--	AB--	BA--	BB--		
	Q1-Q2	--A_	--B_	--C_	--AA	--AB	--BC
Level 1	Q2	B-BD	B-BE	B-BF	B-CC	B-CD	B-CE
		A-A_	A-B_	A-C_	B-AA	B-AB	B-BC
	Q1	-AA_	-AB_	-AC_	-BAA	-BAB	-BBC
		-BBD	-BBE	-BBF	-BCC	-BCD	-BCE
Level 0	None	AAA-	AAB-	AAC-	ABAA	ABAB	ABBC
		ABBD	ABBE	ABBF	ABCC	ABCD	ABCE
		BAAA	BAAB	BABC	BABD	BABE	BABF
		BACC	BACD	BACE	BBAA	BBAB	BBBC
		BBBD	BBBE	BBBF	BBCC	BBCD	BBCE

Figure 5

The names of the drafts in Figure 5 are illustrated by the following example:

In A-C_,

- the A indicates an A answer to Q1,
- the - indicates that Q2 has not been resolved,
- the C indicates a C answer to Q3,
- the _ indicates that the question Q4 does not arise because of previous answers.

Article 235 Levels of Ambiguity

So far, Article 235 has been considered at two levels of ambiguity:

- (A) the 4th level, which is the single textual version that is the present language with its four ambiguities and 30 alternative structural interpretations, and
- (B) the 0th level, which has 30 different textual versions, each of which is without structural ambiguity and for which there is just one structural interpretation.

For Article 235 there are three other levels of ambiguity to be considered -other levels at which drafters might find desirable to state Article 235 and choose to do so. The 3rd level, the 2nd level, and the 1st level will each be considered in detail.

Article 235 3rd Level of Ambiguity

The 3rd level will retain three of the ambiguities of the present language of Article 235 and replace one of them with a defined structural term of the A-Hohfeld language. There are two different combinations of the four ambiguities present at the 3rd level: the Q2-Q3-Q4 combination in which the Q2, Q3, and Q4 ambiguities are retained and the Q1 ambiguity is resolved and the Q1-Q3-Q4 combination in which the Q1, Q2, and Q3 ambiguities are retained and the Q2 ambiguity is resolved. For each of these combinations, there are multiple alternative structural interpretations of the combined three retained ambiguities. There are 12 alternative structural interpretations of the first version of each of the two combinations at the 3rd level of ambiguity, and 18 such interpretations for the second version of each of those two combinations.

Article 235 Combination Q2-Q3-Q4 of the 3rd Level of Ambiguity (Q1 resolved)

In the first combination, the ambiguity that is brought to attention by Q1 is resolved by a drafter choosing to re-express Article 235 in one of the two following ways of drafting the text.

By choosing to express the Q1-ambiguity as a single conditional:

Draft 1 [A---] where the expression in square brackets indicates how one or more of the questions are answered. The A in A--- for Draft 1

indicates that the answer to Q1 is A, and the --- indicates that the Q2, Q3, and Q4 ambiguities are not resolved.

IF

1. action by the Community has been proved necessary to attain, in the course of the operation of the common market, one of the objectives of the Community, AND
2. this Treaty has not provided the necessary powers,

THEN

3. the Council shall, acting unanimously on a proposal from the Commission and after consulting the European Parliament, take the appropriate measures.

Or by choosing to express the Q1 -ambiguity in the draft as a pair of conditionals.

Draft 2 [B---]

Draft 1 lines 1-5*

3. the Council shall, acting unanimously on a proposal from the Commission and after consulting the European Parliament, take the appropriate measures,

BUT OTHERWISE, NOT.

The Q1 single-conditional version of Article 235 has the 12 alternative structural interpretations summarized in Figure 6.

Q1 SINGLE-CONDITIONAL VERSION 12 DIFFERENT STRUCTURAL INTERPRETATIONS

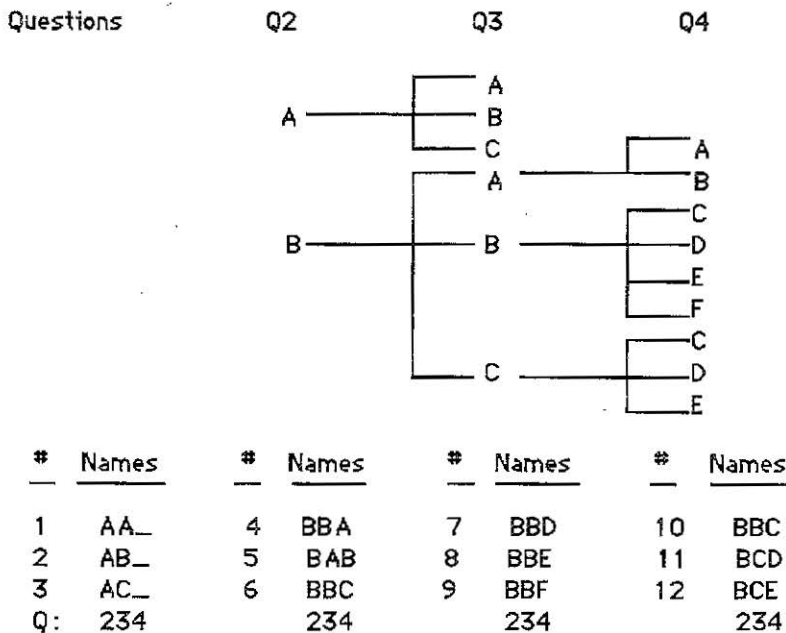

Figure 6

* where Draft X, lines Y-Z indicates that the text from lines Y-Z of Draft X should be inserted here.

CONTROLLING INADVERTENT AMBIGUITY IN LEGAL DRAFTING

The Q1 double-conditional version of Article 235 has the 18 alternative structural interpretations summarized in Figure 7.

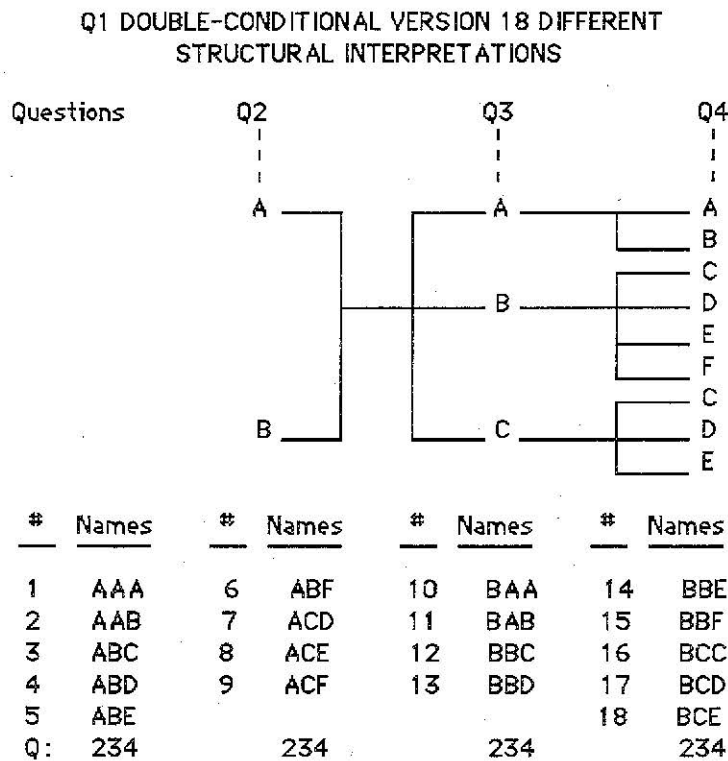

Figure 7

Turning now to the second combination at the 3rd level of ambiguity where it is the Q1, Q2, and Q3 ambiguities that are retained the Q2 ambiguity that is resolved, there is marked similarity to the first combination.

Article 235 Combination Q1-Q3-Q4 of the 3rd Level of Ambiguity (Q2 resolved)

In the second combination, the ambiguity that is brought to attention by Q2 is resolved by a drafter choosing to re-express Article 235 in one of the two following ways of drafting the text.

By choosing to express the consequent of the "if" as a single conditional:

Draft 3 [-A--]

If action by the Community should prove necessary to attain, in the course of the operation of the common market, one of the objectives of the Community and this Treaty has not provided the necessary powers,

IF

1. the Council has received a proposal for such action from the Commission,
AND
2. the Council is acting unanimously on the proposal for such action, AND
3. the Council has consulted the European Parliament on such action,
THEN
4. the Council shall take the appropriate measures.

Or by choosing to express that consequent as a pair of conditionals:

Draft 4 [-B--]

Draft 3, lines 1-8

4. the Council shall take the appropriate measures,
BUT OTHERWISE, NOT.

The Q2 single-conditional version of Article 235 has the 12 alternative structural interpretations summarized in Figure 8.

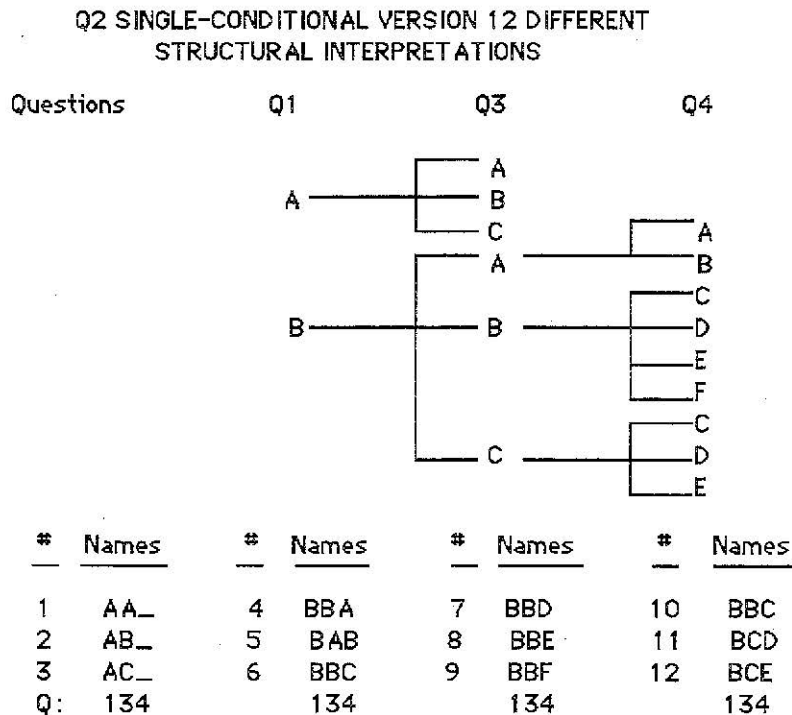

Figure 8

The Q2 double-conditional version of Article 235 has the 18 alternative structural interpretations summarized in Figure 9.

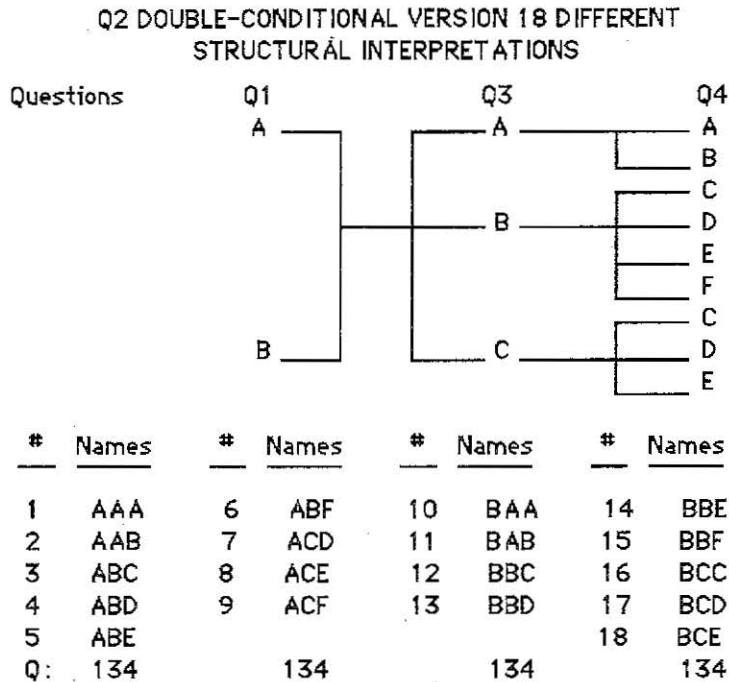

Figure 9

Moving to the 2nd level of ambiguity, it is like the 3rd level in having two combinations of ambiguities. But unlike the combinations at the 3rd level, the combinations at the 2nd level differ markedly in their number of versions and the number of structural interpretations of the various versions.

Article 235 2nd Level of Ambiguity

The 2nd level of ambiguity will retain two of the four ambiguities of the present language of Article 235 and replace the other two with defined structural terms of the A-Hohfeld language. Like the 3rd level, there are two different combinations of the four ambiguities present at the 2nd level: the Q1-Q2 combination in which the Q1 and Q2 ambiguities are retained and the Q3 and Q4 ambiguities are resolved and the Q3-Q4 in which the Q3 and Q4 ambiguities are retained and the Q1 and Q2 ambiguities are resolved. For each of these combinations at the 2nd level, there are multiple alternative structural interpretations of the combined two retained ambiguities. For the first combination, the Q3-Q4 combination in which the Q1 and Q2 ambiguities are resolved, there are four versions that a drafter can choose among. The first version has three structural interpretations, and the last three versions each have nine structural interpretations.

Article 235 Combination Q3-Q4 of the 2nd Level of Ambiguity (Q1 and Q2 resolved)

In the first combination, the ambiguities that are brought to attention by Q1 and Q2 are resolved by a drafter choosing to re-express Article 235 in one of four different ways of drafting the text.

In the first way, the ambiguities are resolved by choosing to express the Q1 and Q2 ambiguities both as single conditionals:

Draft 5 [AA--]

IF

1. action by the Community has been proved necessary to attain, in the course of the operation of the common market, one of the objectives of the Community, AND

2. this Treaty has not provided the necessary powers,

THEN

3. IF

A. the Council has received a proposal for such action from the Commission, AND

B. the Council is acting unanimously on the proposal for such action, AND

C. the Council has consulted the European Parliament on such action,

THEN

D. the Council shall take the appropriate measures.

The Q1-single and Q2-single conditional version of Article 235 has the 3 alternative structural interpretations summarized in Figure 10.

**Q1-SINGLE AND Q2-SINGLE CONDITIONAL VERSION
3 DIFFERENT STRUCTURAL INTERPRETATIONS**

Question	Q3
	A
	B
	C
	# <u>Names</u>
1	A
2	B
3	C
Q:	3

Figure 10

In the second way, the ambiguities are resolved by choosing to express the Q1-ambiguity in the draft as a single conditional and the Q2-ambiguity as a pair of conditionals:

Draft 6 [AB--]

Draft 5, lines 1-9

D. the Council shall take the appropriate measures,

BUT OTHERWISE,

E. NOT.

The Q1-single and Q2-double-conditional version of Article 235 has the 9 alternative structural interpretations summarized in Figure 11.

Q1-SINGLE AND Q2-DOUBLE CONDITIONAL VERSION
9 DIFFERENT STRUCTURAL INTERPRETATIONS

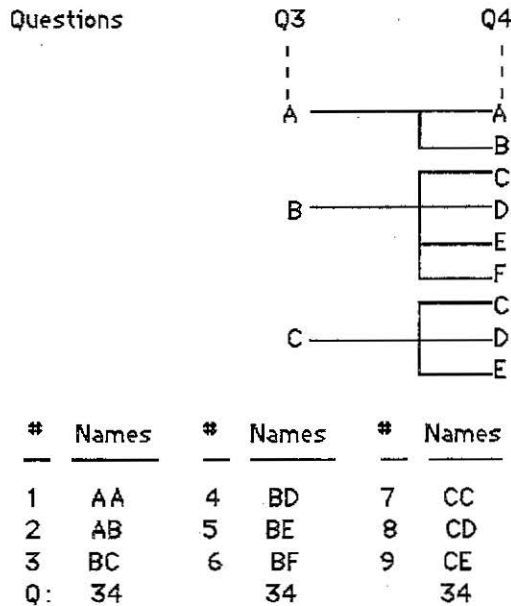

Figure 11

In the third way, the ambiguities are resolved by choosing to express the Q1-ambiguity in the draft as a pair of conditionals and the Q2-ambiguity as a single conditional:

Draft 7 [BA--]

Draft 5 lines 1-10

- D. the Council shall take the appropriate measures,
- BUT OTHERWISE,
- 4. NOT.

The Q1-double and Q2-single conditional version of Article 235 has the same 9 alternative structural interpretations summarized in Figure 9 above that the Q1-single and Q2-double conditional version has.

And finally, in the fourth way, the ambiguities are resolved by choosing to express both the Q1 and Q2 ambiguities as pairs of conditionals:

Draft 8 [BB--]

1. action by the Community has been proved necessary to attain, in the course of the operation of the common market, one of the objectives of the Community, AND
2. this Treaty has not provided the necessary powers, AND

3. the Council has received a proposal for such action from the Commission,
AND
4. the Council is acting unanimously on the proposal for such action, AND
5. the Council has consulted the European Parliament on such action,
THEN
6. the Council shall take the appropriate measures
BUT OTHERWISE, NOT.

This Q1-double and Q2-double conditional version of Article 235 also has the same 9 alternative structural interpretations summarized in Figure 10 above that the Q1-single and Q2-double conditional version has.

Turning now to the second combination at the 2nd level of ambiguity, the Q1-Q2 combination in which the ambiguities that are brought to attention by Q3 and Q4 are resolved, a drafter has many more ways to choose among in re-expressing Article 235 for this combination.

Article 235 Combination Q1-Q2 of the 2nd Level of Ambiguity (Q3 and Q4 resolved)

In this second combination, the ambiguities that are brought to attention by Q3 and Q4 are resolved by a drafter choosing to re-express Article 235 in one of the following 12 different ways of drafting the text.

In the first way, the Q3-ambiguity is resolved by a drafter choosing "shall" as expressing an obligation of the Council in the draft, and the Q4-ambiguity is just not resolved; Q4 does not arise because of the answers given to Q1 and Q2.

Draft 9 [--A_]

If action by the Community should prove necessary to attain, in the course of the operation of the common market, one of the objectives of the Community and this Treaty has not provided the necessary powers, acting unanimously on a proposal from the Commission and after consulting the European Parliament, the Council **MUST** take the appropriate measures.

In the second way, the Q3-ambiguity is resolved by a drafter choosing "shall" as expressing a power of the Council that it has an obligation to exercise in the draft, and the Q4-ambiguity is just not resolved; Q4 does not arise because of the answers given to Q1 and Q2.

Draft 10 [--B_]

Draft 9, lines 1-3

acting unanimously on a proposal from the Commission and after consulting the European Parliament, the Council (1) has **POWER** to take the appropriate measures and (2) **MUST** exercise it.

In the third way, the Q3-ambiguity is resolved by a drafter choosing "shall" as expressing a power of the Council that it has discretion about whether or not to exercise in the draft, and the Q4-ambiguity is just not resolved; Q4 does not arise because of the answers given to Q1 and Q2.

CONTROLLING INADVERTENT AMBIGUITY IN LEGAL DRAFTING

Draft 11 [--C_]

Draft 9, lines 1-3

acting unanimously on a proposal from the Commission and after consulting the European Parliament, the Council (1) has POWER to take the appropriate measures and (2) MAY BUT NEED NOT exercise it.

These first three ways that the S3 and S4 ambiguities are resolved are associated with a single structural interpretation of Q1 and Q2, the one shown in Figure 12.

THE ONE STRUCTURAL INTERPRETATION OF THE THREE WAYS OF RESOLVING S3 AND S4 AMBIGUITIES WHEN S4 IS NOT ASKED

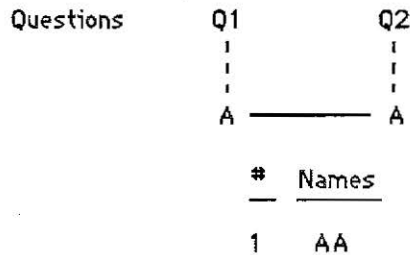

Figure 12

The next nine ways that S3 and S4 ambiguities are resolved, on the other hand, are associated with three alternative structural interpretations. These ways are the ones that deal with the situation in which S4 is asked. Their three structural interpretations are summarized in Figure 13.

THE THREE STRUCTURAL INTERPRETATIONS OF THE NINE WAYS OF RESOLVING S3 AND S4 AMBIGUITIES WHEN S4 IS ASKED

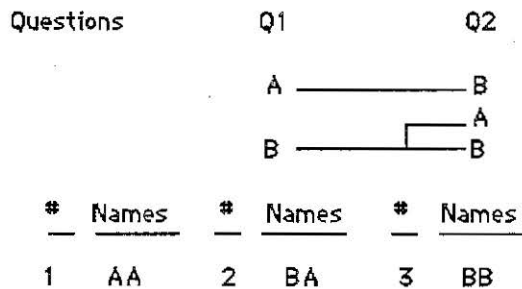

Figure 13

In the fourth way, the Q3-ambiguity is resolved by a drafter choosing "shall" as expressing an obligation of the Council, and the Q4-ambiguity is resolved by choosing its negative as expressing the Council's discretion about taking the appropriate measures.

Draft 12 [--AA]

Draft 9, lines 1-3

acting unanimously on a proposal from the Commission and after consulting the European Parliament, the Council MUST take the appropriate measures, BUT OTHERWISE, the Council MAY BUT NEED NOT take such measures.

In the fifth way, the Q3-ambiguity is resolved by a drafter choosing "shall" as expressing an obligation of the Council in the draft, and the Q4-ambiguity is resolved by choosing its negative as expressing the Council's obligation not to take the appropriate measures.

Draft 13 [--AB]

Draft 9, lines 1-3

acting unanimously on a proposal from the Commission and after consulting the European Parliament, the Council MUST take the appropriate measures, BUT OTHERWISE, the Council MUST NOT take such measures.

In the sixth way, the Q3-ambiguity is resolved by a drafter choosing "shall" as expressing a power of the Council and its obligation to exercise it in the draft, and the Q4-ambiguity is resolved by choosing its negative as expressing the Council's lack of such power and its discretion to engage in activities that would exercise such power.

Draft 14 [--BC]

Draft 9, lines 1-3

acting unanimously on a proposal from the Commission and after consulting the European Parliament, the Council (1) has POWER to take the appropriate measures and (2) MUST exercise it, BUT OTHERWISE, the Council (1) lacks such POWER and (2) MAY BUT NEED NOT engage in action that would exercise such POWER.

In the seventh way, the Q3-ambiguity is resolved by a drafter choosing "shall" as expressing a power of the Council and its obligation to exercise it in the draft, and the Q4-ambiguity is resolved by choosing its negative as expressing the Council's lack of such power and its obligation not to engage in activities that would exercise such power.

Draft 15 [--BD]

Draft 9, lines 1-3

acting unanimously on a proposal from the Commission and after consulting the European Parliament, the Council (1) has POWER to take the appropriate measures and (2) MUST exercise it, BUT OTHERWISE, the Council (1) lacks such POWER and (2) MUST NOT engage in action that would exercise such POWER.

In the eighth way, the Q3-ambiguity is resolved by a drafter choosing "shall" as expressing a power of the Council and its obligation to exercise it in the draft, and

the Q4-ambiguity is resolved by choosing its negative as expressing such power of the Council but it's obligation not to exercise that power.

Draft 16 [--BE]

Draft 9, lines 1-3

acting unanimously on a proposal from the Commission and after consulting the European Parliament, the Council (1) has POWER to take the appropriate measures and (2) MUST exercise it, BUT OTHERWISE, the Council (1) has such POWER but (2) MUST NOT exercise it.

In the ninth way, the Q3-ambiguity is resolved by a drafter choosing "shall" as expressing a power of the Council and its obligation to exercise it in the draft, and the Q4-ambiguity is resolved by choosing its negative as expressing such power of the Council and its discretion about exercising such power.

Draft 17 [--BF]

Draft 9, lines 1-3

acting unanimously on a proposal from the Commission and after consulting the European Parliament, the Council (1) has POWER to take the appropriate measures and (2) MUST exercise it, BUT OTHERWISE, the Council (1) has such POWER and (2) MAY BUT NEED NOT exercise it.

In the tenth way, the Q3-ambiguity is resolved by a drafter choosing "shall" as expressing a power of the Council and its discretion about exercising it in the draft, and the Q4-ambiguity is resolved by choosing its negative as expressing the Council's lack of such power and it's discretion about engaging in action that would exercise such power.

Draft 18 [--CC]

Draft 9, lines 1-3

acting unanimously on a proposal from the Commission and after consulting the European Parliament, the Council (1) has POWER to take the appropriate measures, the Council has POWER to take the appropriate measures and (2) MAY BUT NEED NOT exercise it, BUT OTHERWISE, the Council (1) lacks such POWER and (2) MAY BUT NEED NOT engage in action that would exercise such POWER.

In the eleventh way, the Q3-ambiguity is resolved by a drafter choosing "shall" as expressing a power of the Council and its discretion about exercising it in the draft, and the Q4-ambiguity is resolved by choosing its negative as expressing the Council's lack of such power and its obligation not to engage in action that would exercise such power.

Draft 19 [--CD]

Draft 9, lines 1-3

acting unanimously on a proposal from the Commission and after consulting the European Parliament, the Council (1) has POWER to take the appropriate measures and (2) MAY BUT NEED NOT exercise it, BUT OTHERWISE, the

Council (1) lacks such POWER and (2) MUST NOT engage in action that would exercise such POWER.

And finally, in the twelfth way, the Q3-ambiguity is resolved by a drafter choosing "shall" as expressing a power of the Council and its discretion about exercising it in the draft, and the Q4-ambiguity is resolved by choosing its negative as expressing such power of the Council but its obligation not to exercise it.

Draft 20 [--CE]

Draft 9, lines 1-3

acting unanimously on a proposal from the Commission and after consulting the European Parliament, the Council (1) has POWER to take the appropriate measures and (2) MAY BUT NEED NOT exercise it, BUT OTHERWISE, the Council (1) has such POWER but (2) MUST NOT exercise it.

With this twelfth and final way that a drafter can resolve the Q3 and Q4 ambiguities for the R1-R2 combination at the 2nd level, the description of this 2nd level of ambiguity of Article 235 is completed, and we turn to a description of the 1st level of ambiguity.

Article 235 1st Level of Ambiguity

The 1st level of ambiguity is like the 2nd and 3rd in having two combinations of ambiguities. At this level, a single ambiguity is retained and the three others are resolved by replacing the language that expresses them with defined structural terms of the A-Hohfeld language. Where the 3rd and 2nd levels have two different combinations of the ambiguities present, there are just two single ambiguities present at the 1st level, the Q2 ambiguity and the Q1 ambiguity. For each of these ambiguities at the 1st level, there are multiple alternative structural interpretations.

Article 235 Ambiguity Q2 of the 1st Level of Ambiguity (Q1, Q3, and Q4 resolved)

For the first ambiguity, the one for which the Q1, Q3, and Q4 ambiguities are resolved and the Q2 ambiguity is retained, there are a total of twelve drafts that a drafter can choose among. Upon first glance these drafts appear to be ambiguous with respect to Q2, but upon deeper analysis the absence in each of first three of the twelve drafts of a resolution of Q4 indicates the drafter's expectation of an A answer to Q2.

In the first of the three ways, the Q1 ambiguity is resolved by a drafter choosing "If" as expressing a single conditional in the draft, the Q3 ambiguity is resolved by choosing "shall" as expressing an obligation of the Council, and the Q4-ambiguity is not resolved because Q4 does not arise as a question due to the A the answer given to Q1. The absence of resolution of Q4, which is indicated by the "_", is the indication that the drafter expects an A answer to Q2 in addition to the A answer explicitly given for Q1.

Draft 21 [A-A_]

IF

1. action by the Community has been proved necessary to attain, in the course of the operation of the common market, one of the objectives of the Community, AND
2. this Treaty has not provided the necessary powers,

THEN

3. acting unanimously on a proposal from the Commission and after consulting the European Parliament, the Council MUST take the appropriate measures.

This Draft 21 is just like Draft 9 of the Q1-Q2 Combination of the 2nd level of ambiguity, except that Draft 9 leaves the Q1 ambiguity unresolved in the text and Draft 21 indicates an A answer to Q1. Similarly, in the second and third of the first three ways of resolving the Q2 ambiguity, a drafter has options that are like the second and third drafts of the Q1-Q2 Combination (Drafts 10 and 11) except that Q1 is resolved by an A answer. Thus, the Draft 22 [A-B_] and the Draft 23 [A-C_] (not shown here) similarly indicate that the drafter expects an A answer to Q2 because of the absence of a resolution of Q4.

Since these first three drafts of Ambiguity Q2 at the 1st level of ambiguity all indicate that the drafter expects an A resolution of the Q2 ambiguity in each of them, it probably would be better to use the corresponding draft for each at the 0th level of ambiguity in which this A resolution of Q2 is explicitly stated. Use AAA_ for A-A_, AAB_ for A-B_, and AAC_ for A-C_.

The last nine ways of resolving the Q2 ambiguity are also like the last nine drafts of the Q1-Q2 Combination (Drafts 12-20) except that the Q1 is resolved by an B answer. Unlike in the first three drafts, in these last nine drafts for the Q2 ambiguity (Drafts 24-32: B-AA, B-AB, B-BC, B-BD, B-BE, B-BF, B-CC, B-CD, and B-CE) there is no telegraphing of the drafters intent about the resolution of the Q2 ambiguity. The wording and structure of the these drafts clearly indicate both that the answer to Q1 is B and that the answer to Q2 can be either A or B.

For example, in Draft 31 below, Result 4 occurs when either Condition 1 or Condition 2 is not fulfilled, and neither the wording nor the structure indicates whether a result like Result 4 is meant to occur when, say, the European Parliament has not been consulted and all other conditions have been fulfilled.

Draft 31 [B-CD]

IF

1. action by the Community has been proved necessary to attain, in the course of the operation of the common market, one of the objectives of the Community, AND
2. this Treaty has not provided the necessary powers,

THEN

3. acting unanimously on a proposal from the Commission and after consulting the European Parliament, the Council (1) has POWER to take the appropriate measures and (2) MAY BUT NEED NOT exercise it,

BUT OTHERWISE,

4. in so acting and consulting the Council (1) lacks such POWER and (2) MUST NOT engage in action that would exercise such POWER.

If the Q2 ambiguity were resolved with an A answer, the draft would be the structural interpretation BACD, which would be the following Draft 64:

Draft 64 [BACD] (Clear Normalized Version of Interpretation BACD)

IF

1. action by the Community has been proved necessary to attain, in the course of the operation of the common market, one of the objectives of the Community, AND
2. this Treaty has not provided the necessary powers,

THEN

IF

3. A. the Council has received a proposal for such action from the Commission, AND
- B. the Council is acting unanimously on the proposal for such action, AND
- C. the Council has consulted the European Parliament on such action,

THEN

- D. the Council (1) has POWER to take the appropriate measures and (2) MAY BUT NEED NOT exercise it,

BUT OTHERWISE,

4. the Council (1) lacks such POWER and (2) MAY BUT NEED NOT engage in action that would exercise such POWER.

That the answer to Q2 is A in Draft 64 (and not B) is indicated clearly by the absence of any Result 3E. If the Q2 ambiguity were resolved with an B answer, its resulting Draft 73 would be like Draft 64 except for the addition of the following result after the text of Condition 3D:

BUT OTHERWISE,

- 3E. the Council (1) lacks such POWER and (2) MAY BUT NEED NOT engage in action that would exercise such POWER.

Such a resulting Draft 73 would be logically equivalent to the Interpretation BBCD above on page 17, which is simpler and less repetitious, and thus, the clearly preferred rendition of Draft 73.

Article 235 Ambiguity Q1 of the 1st Level of Ambiguity (Q2, Q3, and Q4 resolved)

For the second ambiguity, the one for which the Q2, Q3, and Q4 ambiguities are resolved and the Q1 ambiguity is retained, there is a set of 12 drafts that a drafter can choose among that is also similar to the set of twelve drafts available for Combination Q1-Q2, except that the set available for the Q1 ambiguity includes a resolution of the Q2 ambiguity.

For example,

CONTROLLING INADVERTENT AMBIGUITY IN LEGAL DRAFTING

Draft 43 [-BCD]

If action by the Community should prove necessary to attain, in the course of the operation of the common market, one of the objectives of the Community and this Treaty has not provided the necessary powers,

IF

1. the Council has received a proposal for such action from the Commission, AND
2. the Council is acting unanimously on the proposal for such action, AND
3. the Council has consulted the European Parliament on such action,

THEN

4. the Council (1) has POWER to take the appropriate measures and (2) MAY BUT NEED NOT exercise it, BUT OTHERWISE,
5. the Council (1) lacks such POWER and (2) MUST NOT engage in action that would exercise such POWER.

The twelve drafts are Drafts 33-44: -AA_, -AB_, -AC_, -BAA, -BAB, -BBC, -BBD, -BBE, -BBF, -BCC, -BCD, and -BCE. For Ambiguity Q1, a choice by the drafter of any of the first three of the twelve drafts available indicates the drafter's expectation of an A answer to Q1 in a way similar to the way that the choice of any of the first three drafts for Ambiguity Q2 indicates a drafter's expectation of an A answer to Q2. Because of this similar indication of expectation, it probably would also be better to use for these three drafts of the Q1 Ambiguity, the corresponding draft for each of them at the 0th level of ambiguity in which these A resolutions of Q1 are explicitly stated. Use AAA_ for -AA_, AAB_ for -AB_, and AAC_ for -AC_. For a choice by the drafter of any of the last nine drafts for Ambiguity Q1, there would not be any such telegraphing of the intention of the drafter about the resolution of Q1 in a way that is similar to the absence of such indication of intention in the last nine drafts for Ambiguity Q2. The rest of the analysis of the last nine drafts for Ambiguity Q1 is similar to the analysis above of the last nine drafts for Ambiguity Q2.

With these 24 drafts at the 1st level of ambiguity combined with the 16 drafts of the 2nd level and the four drafts of the 3rd level, there are a total of 44 alternative drafts of Article 235 in addition to the present text of the Article at the 4th level, all of which contain varying amounts of structural ambiguity. This concludes the description of the ambiguous alternative drafts of Article 235. Attention now shifts to the 30 unambiguous alternative drafts, which are the 30 alternative structural interpretations of the 4th level of ambiguity present text of Article 235.

Article 235 0th Level of Ambiguity

The additional 30 different drafts at the 0th level of ambiguity contain none of the structural ambiguities identified by the four questions, Q1-Q4. All of the ambiguities are resolved in each of these unambiguous drafts (Drafts 45-74:

AAA_, AAB_, AAC_, ABAA, ABAB, ABBC, ABBD, ABBE, ABBF, ABCC, ABCD, ABCE, BAAA, BAAB, BABC, BABD, BABE, BABF, BACC, BACD, BACE, BBAA, BBAB, BBBC, BBBB, BBBE, BBBF, BBCC, BBBD, and BBCE). One of these unambiguous drafts is set forth above as Structural Interpretation BBBD; it is Draft 73. A second example of an unambiguous draft will facilitate further understanding how the other 28 unambiguous drafts can be pieced together from the alternative answers to the four structural questions. Consider Draft 63, which is Structural Interpretation BACC.

Draft 63 [BACC] (Clear Normalized Version of Interpretation BACC)

IF

1. action by the Community has been proved necessary to attain, in the course of the operation of the common market, one of the objectives of the Community, AND
2. this Treaty has not provided the necessary powers,

THEN

IF

3. A. the Council has received a proposal for such action from the Commission, AND
- B. the Council is acting unanimously on the proposal for such action, AND
- C. the Council has consulted the European Parliament on such action,

THEN

- D. the Council (1) has POWER to take the appropriate measures and (2) MAY BUT NEED NOT exercise it,

BUT OTHERWISE,

4. the Council (1) lacks POWER to take the appropriate measures and (2) MAY BUT NEED NOT engage in action that would exercise such POWER.

In this Draft 63 the Result 3D occurs when Conditions 1, 2, 3A, 3B, and 3C are fulfilled, and Result 4 occurs only when either Condition 1 or Condition 2 (or both) is not fulfilled.

The B answer to Q1 in BACC

- (1) determines the "IF" and the "THEN" at the location of the left margin,
- (2) determines the enumeration of Condition 1 and Condition 2 at the left margin,
- (3) determines the location of the "BUT OTHERWISE" that precedes Result 4 at the left margin, and
- (4) along with the Q3 answer of C and the Q4 answer of C, determines the text of Result 4.

The A answer to Q2 in BACC

- (1) determines the "IF" and the "THEN" at the location of the first indentation from the left margin,
- (2) determines the "enumeration" (with capital letters as "enumerators") of Condition 1 and Condition 2 at the first indentation from the left margin,
- (3) determines the absence of a "BUT OTHERWISE" after Result 3D at the first indentation of from the left margin, and

- (4) determines the absence of a Result 3E, having the same text at that of Result 4.

The answer C to Q3 in BACC

- (1) determines the text of Result 3D, and
(2) along with the Q1 answer of B and the Q4 answer of C, determines the text of Result 4.

The answer C to Q4 in BACC, along with the Q1 answer of B and the Q3 answer of C, determines the text of Result 4.

In a similar manner, the text to each of the other 29 drafts of Article 235 at the 0th level of ambiguity are determined by the pattern of answers given to questions Q1-through Q4.

This concludes the rather detailed consideration and illustration of the type of control of ambiguity that can occur by varying the level of the ambiguity raised by the structural questions. It is not the only type of such control; there others that will be more briefly mentioned.

Some Other Types of Control of the Level of Ambiguity

The first other type of control of ambiguity that deserves mention is one that already occurs with great frequency. The drafter can vary how completely it is specified who the legal persons are who are involved in a legal DUTY (or RIGHT or NORIGHT or PRIVILEGE) relationship.

At the least ambiguous level, both classes of persons are specified: both who owes the DUTY and to whom it is owed.

Class-A of persons have a DUTY to class-B of persons to refrain from doing class-C acts.

At the intermediate level, one or the other of the classes of persons involved is omitted:

Class-A of persons MUST refrain from doing class-C acts.

or:

Class-C acts MUST NOT be done for class-B of persons.

At the most ambiguous level, both classes of persons involved are omitted:

IT IS FORBIDDEN THAT class-C acts are done.

Or by adding the following new definition to the current list of 35 definitions in the A-Hohfeld language:

"a is **FORBIDDEN**" means

"IT IS FORBIDDEN THAT a." which, in turn, means

"IF 1. the state of affairs described by sentence-a is NOT so,
THEN 2. there is a violation, AND

3. the legal system will provide a remedy with respect to the violator."

there would be the more perspicuous rendition:

Class-C acts are FORBIDDEN.

which, of course, could also be expressed:

Class-C acts **MUST NOT** be done.

A second other type of control of ambiguity that deserves mention is one that would add another alternative interpretation to the "shall" ambiguity of question Q3 and a pair of alternative interpretations to the "negative of shall" of Q4. This is the interpretation of "shall" as a "bare" POWER:

D) the Council has POWER to take the appropriate measures

With the appropriate definitions added to the current list of 35 A-Hohfeld definitions, the other two POWER alternatives for Q3 could become:

B) the Council has OBLIGATORY POWER to take the appropriate measures

C) the Council has DISCRETIONARY POWER to take the appropriate measures

and the added alternative interpretation to Q4 would be:

G) the Council lacks POWER to take the appropriate measures

and the other two POWER alternatives for Q4 could become:

E) the Council has FORBIDDEN POWER to take the appropriate measures

F) the Council has DISCRETIONARY POWER to take the appropriate measures

The added new definitions to the current list of 35 definitions in the A-Hohfeld language would be:

"p1 has **FORBIDDEN POWER** to create legal relation-1r." means

"p1 has POWER to create legal relation-1r, but **MUST NOT** exercise it."

"p1 has **OBLIGATORY POWER** to create legal relation-1r." means

"p1 has POWER to create legal relation-1r, and **MUST** exercise it."

"p1 has **DISCRETIONARY POWER** to create legal relation-1r." means

"p1 has POWER to create legal relation-1r and **MAY BUT NEED NOT** exercise it."

These three kinds of POWER are a mutually exclusive and exhaustive list of the different kinds of POWER of the A-Hohfeld language. This means that an alternative like the newly-added D) of Q3, where it is not stated whether the POWER is FORBIDDEN, OBLIGATORY, or DISCRETIONARY, is a deliberate signal by the drafter of an intention to be ambiguous about which of the three kinds of POWER is meant.

As drafters work with using the A-Hohfeld language, it is likely that there will emerge other types of control over the extent of ambiguity included in legal texts. The three types mentioned in this Article should not be considered an exhaustive list of such types of control, but they do furnish adequate tools for making a

substantial improvement in control of the plethora of inadvertent structural ambiguity in current legal drafting.

There is one final matter to mention that is significant to the enterprise of more adequately controlling the structural ambiguity in legal drafting.

Erosion of Semantics into Logical Structure

Another aspect to the problem of controlling the logical structure of legal text is the shifting character of the distinction between semantics and logical structure as those two concepts are used in this Article. As concepts that would have at one time surely have been regarded as matters of semantics get incorporated into formal systems of logic, they will become matters of logical structure. Prior to the formalization of concepts of "forbidden", "obligated" and "permitted" in deontic logic in 1951⁵, these terms would have been regarded as semantic terms, as would the Hohfeldian fundamental legal conceptions of "right", "duty", "no-right", "privilege", "power", "liability", "disability", and "immunity" prior to their formalization in A-Hohfeld logic⁶. Terms expressing concepts of time and concepts of action have not yet been considered as additions to the A-Hohfeld language, although they are certainly prime candidates for future incorporation. Furthermore, as logicians labor away to relate more that is less completely understood to what they have already formalized, we can rely that there will be increasing parts of what is now natural language that can be added to the store of defined structural terms of the A-Hohfeld language. It is likely to be a slowly, but steadily growing, language -both in its number of terms and in its usefulness for controlling the expression of structural ambiguity in legal drafting.

Conclusions

Of the two kinds of imprecision that is pervasive in legal drafting, the one that needs attention most is imprecision in the expression of the logical structure of legal rules. Structural ambiguities are most often inadvertent, while the occurrence of semantic vagueness in legal drafting tends to be more deliberate. For deliberately controlling inadvertent structural ambiguities, the A-Hohfeld language, which currently consists of 35 definitions of structural terms (and four possible additions), is proposed. Its use in controlling structural ambiguity at four different levels of ambiguity has been illustrated in detail with respect to Article 235 of the treaty that established the European Economic Community, and two other uses have been described more briefly. The A-Hohfeld definitions are tailored tools for precisely controlling structural imprecision. As we seek to craft legal architecture fit for the twenty-first century, natural language unadorned with structural definitions will doom the legal landscape to the continued clutter of inadvertencies in structural prose. Law needs some precision-power packed into its linguistic apparatus; A-Hohfeld is one way.

* University of Michigan

** Eastern Michigan University

Notes

- 1 Hart, H.L.A.: 1958, 'Separation of Law and Morals', *Harvard Law Review* 71, 593-609, 607. See also, Hart, H.L.A.: 1961, *The Concept of Law*, Oxford, Clarendon Press, p. 124.
- 2 Allen, Layman E., Saxon, Charles S.: 1985, 'One Use of Computerized Instructional Gaming in Legal Education: To Better Understand the Rich Logical Structure of Legal Rules and Improve Legal Writing', *The University of Michigan Journal of Law Reform* 18, 383-487.
- 3 Allen, Layman E.: 1974, 'Formalizing Hohfeldian Analysis to Clarify the Multiple Senses of 'Legal Right': A Powerful Lens for the Electronic Age', *Southern California Law Review* 48, 428-487. Allen, Layman E., Saxon, Charles S.: 1986, 'Analysis of the Logical Structure of Legal Rules by a Modernized and Formalized Version of Hohfeld's Fundamental Legal Conceptions', in A.A. Martino and F.S. Natali (eds.): *Automated Analysis Of Legal Texts: Logic, Informatics, Law*, Amsterdam, North-Holland. And Allen, Layman E., Saxon, Charles S.: 1993, 'A-Hohfeld: A Language for Robust Structural Representation of Knowledge in the Legal Domain to Build Interpretation-Assistance Expert Systems', in J.J. Meyer and R.J. Wieringa (eds.): *Deontic Logic in Computer Science: Normative System Specification*, John Wiley & Sons, 205-224.
- 4 For a more detailed description of the process of NORMALIZATION see, Allen, Layman E., Saxon, Charles S.: 1985, 'Computer Aided Normalizing and Unpacking: Some Interesting Machine-Processable Transformations of Legal Rules', in Charles Walter (ed.): *Computing Power and Legal Reasoning*, West Publishing Co. And Allen, Layman E., Saxon, Charles S.: 1988, 'Automatic Generation of a Legal Expert System of Section 7 (2) of the United Kingdom Data Protection Act 1984', *Theoria* 7-8-9.
- 5 von Wright, Georg.: 1951, 'Deontic Logic', *Mind* 1, p. 60.
- 6 Kanger, Stig and Kanger, Helle: 1966, 'Rights and Parliamentarism,' *Theoria* 32, 85-115. Fitch, Frederic B.: 1967, 'A Revision of Hohfeld's Theory of Legal Concepts', *Logique et Analyse* 10, 269-276. Anderson, Alan R.: 1971, 'The Logic of Hohfeldian Propositions', *Pittsburgh L. Rev.* 33, 29-38. Lindahl, Lars: 1977, *POSITION AND CHANGE: A Study of Law and Logic*, Dordrecht-Holland, D. Reidel Publishing Company.

† Published with permission of the *Istituto per la Documentazione Giuridica di Consiglio Nazionale delle Ricerche*, Florence.