

## The University of Akron IdeaExchange@UAkron

---

Honors Research Projects

The Dr. Gary B. and Pamela S. Williams Honors  
College

---

Spring 2016

# Pediatric Electrical Stimulation for Limb Lengthening: A Non-Invasive Approach

Corey J. Schurko

*University of Akron*, [cjs125@zips.uakron.edu](mailto:cjs125@zips.uakron.edu)

Sofia Chinchilla

*University of Akron*, [sc118@zips.uakron.edu](mailto:sc118@zips.uakron.edu)

Amanda E. Pinheiro

*University of Akron*, [aep42@zips.uakron.edu](mailto:aep42@zips.uakron.edu)

Jacob A. Brock

*University of Akron*, [jab301@zips.uakron.edu](mailto:jab301@zips.uakron.edu)

Please take a moment to share how this work helps you [through this survey](#). Your feedback will be important as we plan further development of our repository.

Follow this and additional works at: [http://ideaexchange.uakron.edu/honors\\_research\\_projects](http://ideaexchange.uakron.edu/honors_research_projects)

 Part of the [Biomedical Devices and Instrumentation Commons](#)

---

### Recommended Citation

Schurko, Corey J.; Chinchilla, Sofia; Pinheiro, Amanda E.; and Brock, Jacob A., "Pediatric Electrical Stimulation for Limb Lengthening: A Non-Invasive Approach" (2016). *Honors Research Projects*. 285.

[http://ideaexchange.uakron.edu/honors\\_research\\_projects/285](http://ideaexchange.uakron.edu/honors_research_projects/285)

This Honors Research Project is brought to you for free and open access by The Dr. Gary B. and Pamela S. Williams Honors College at IdeaExchange@UAkron, the institutional repository of The University of Akron in Akron, Ohio, USA. It has been accepted for inclusion in Honors Research Projects by an authorized administrator of IdeaExchange@UAkron. For more information, please contact [mjon@uakron.edu](mailto:mjon@uakron.edu), [uapress@uakron.edu](mailto:uapress@uakron.edu).



**Pediatric Electrical Stimulation for Limb Lengthening: A Non-Invasive Approach**

**Honors Research Project Report**

**April 29th, 2016**

**Sofia Chinchilla, Corey Schurko, Jake Brock, Amanda Pinheiro**

## **INTRODUCTION**

Leg Length Discrepancy (LLD) is a problematic ailment for children as the differences in limb lengths can lead to scoliosis, hip, knee, and ankle problems, and back pain. This discrepancy can be caused by a congenital, developmental, or acquired defect. It is quite common in the United States, with 32% of tested military recruits having significant differences in the length of their two legs<sup>1</sup>. The severity can range from a centimeter to several inches with varying methods of treatment<sup>2</sup>. If LLD is untreated, the symptoms will worsen as the child matures. Surgical procedures to fix the discrepancies cost the patient's family more than \$75,000 in addition to potential problems along the way of recovery such as infection<sup>3</sup>. These problems led our group toward designing a medical device with the ability to significantly lengthen limbs through simpler means than the methods currently used in practice. With the help of Dr. Rebecca Willits of University of Akron and Dr. Dennis Weiner of Akron Children's Hospital, we were introduced to cutting edge research on enhancing bone growth for afflicted LLD pediatric patients by electrical stimulation.

After further literature review of the problem on leg length discrepancy in pediatric patients, it became apparent that surgical intervention is problematic and costly while electrical stimulation through capacitive coupling has proven to be effective on enhancing growth. The thought process leading to this conclusion is further outlined in Figure 1 and explores multiple solutions to our detailed problem. External treatment has been proven to address the problem efficiently with the potential to improve the quality of life of the patients. Dr. Willits and Dr. Weiner, our clients for this medical device, have a history of researching the effectiveness of this treatment along with Dr. Safadi of Northeast Ohio Medical University. One published article

uses capacitive coupling stimulation of bovine chondrocytes to prove a significant increase in bone cell growth <sup>4</sup>.

Based off this proven method, our medical device involves two electrodes with an AC voltage source and knee brace that secures them to the site of application. While this type of device already exists in the market for other bone therapies such as non-union fusion, this specific application must first be tested on animal models before humans. Moreover, the existing device was not designed for use with pediatric patients. To assist with research and clinical trials, a computational model with the ability to change electrical parameters according the limb size was requested by our clients MRI image analysis was performed to gain approximate tissue measurements around site of stimulation for use in the model. ImageJ, a free software program developed by the U.S. Government, was utilized to determine the dimensions of the tissue at the growth plate of the tibia. Additionally, this computational model used the resistivities of tissue types to specify a current optimal for proliferative effects<sup>5</sup>. This was vital for the application on animal limbs to gain FDA approval. Although our objective was not fully met due to time restraints, the final device should have a tunable option to account for the specific anatomy of the pediatric patient's' limb.

## **BACKGROUND INFORMATION**

Current methods for treating pediatric limb discrepancies are limited to surgery. Previously, the Ilizarov Method was the prevailing mode of treatment. As displayed in Figure 2, this method uses pins that are externally attached to the broken bone for slight extension overtime using a fixator. This slight separation stimulates bone growth in a stepwise manner. A more modern method uses internal plates that do not require externalization. A third method that is commonly performed by orthopedic surgeons is simply shortening the longer limb to match the shorter one. Unfortunately, all of these treatments require surgery with associated

complications such as prolonged rest time and infection. Several companies, such as Zimmer Biomet, have created an external bone growth stimulator that uses capacitive coupled electrical stimulation to promote bone growth in adults with non-union fractures. Shown in Figure 3, this device delivers about 5-10 mA of current to the bone to promote growth and healing. This device, unfortunately, is only designed for adults and is not FDA approved to address the limb discrepancies in children. While this same type of electrical stimulation is effective for our purposes, it needs to gain the appropriate FDA approval first.

### **PROJECT OBJECTIVES AND GOALS**

The primary goal for this project was to learn and demonstrate the design process by solving a real world medical problem. The second goal was to produce a working prototype device that uses electrical stimulation to enhance longitudinal bone growth for pediatric patients with limb length discrepancies. We hoped to develop a device that would deliver a voltage across the epiphyseal plate of a pediatric femur or tibia (Figure 4), which can stimulate the intended growth as set forth by the model. In conjunction with producing a physical model, we aimed to produce a computational model that represents resistivity values of human tissue in a realistic multilayered form. This was done to develop a better understanding of current distribution in human tissue and to use the data to scale down to an animal model for research and further testing. Our original plan was to study the electrical current dissipation across gelatin and ballistics gel in efforts to understand electrical behavior through physical models, but we decided to focus our effort on the development of the physical and computational models first, as advised by our instructor. Looking forward, a long-term goal of this project is that the device will be used for clinical trial with animals first and then humans. The alpha prototype was developed to demonstrate what the device would be if it were to be used on humans/adolescents. The

components of the alpha prototype can later be scaled down for an animal study using verification from the computational model (the next step before proceeding to human clinical trials with the device).

## **METHODS AND MANUFACTURING**

### **Computational Modeling:**

In order to develop a proper computational model for the electrical stimulation delivered by our device, we required modeling software. These types of software programs perform complex analyses of geometries that are specific to a project. The solutions include an output of various physical parameters that help determine the design of the product. ANSYS Workshop version 15.0 (ANSYS, Inc. Canonsburg, PA) fit best for our purposes. This software models the application of voltage applications across a variety of materials and formed geometries. Other modeling programs, such as Solidworks, do not include the feature of analyzing electrical stimulation. The initial focus was to create a geometrical design that models a human leg with different material layers as represented by Figure 5. The material layers were customized to have the isotropic resistivities of the respective tissue layer as shown in literature<sup>5</sup>. As complications arose with ANSYS's analysis of a complex geometry, it was decided to focus strictly on the cross sectional area of tissue between the stimulating electrodes. Figure 6 shows the area stimulated with 10V by the electrodes through materials characterized by the isotropic resistivities of skin, bone, and muscle at the optimal frequency of 100 kHz<sup>5,6</sup>. The tissue thickness was determined by MRI images of a 15-year-old female, as shown in Figure 7. As shown and expected, bone has a high resistivity of  $10^8 \Omega/\text{cm}$  and causes the largest voltage drop in the model. The current distribution through the area of stimulation was calculated to be 15.7  $\mu\text{A}/\text{m}$  with minor variation.

### **Alpha Prototype:**

Our alpha prototype included a function generator, wires and disposable electrodes. The function generator generated a square AC wave that was carried to the electrodes (Figure 8). In theory the electrodes will deliver this electrical signal to the surface of the skin. Capacitive coupling involves an AC wave through bone and other the tissue layers with each behaving as a capacitor. The signal creates an electric field through the leg as shown in Figure 9. In the setup of our alpha prototype, the square wave had a peak-to-peak voltage of 5V and a frequency of 100 kHz. The values were chosen based on the literature that stated these values were optimal for stimulating bone growth <sup>6,7</sup>.

### **Beta Prototype:**

For our beta prototype, we used a 9V battery and a square wave oscillator circuit (Figure 10) to make a portable device. In Figure 10, the circuit used to obtain our peak-to-peak voltage of 5 V<sub>pp</sub> is represented in the power supply section. A 9V battery outputs approximately ± 4.5 V which ideally would result in a peak-to-peak voltage of 9V, however through testing we have determined that the unaccounted resistance in the circuit requires a higher voltage than ± 2.5 V to generate a peak-to-peak voltage of 5 V<sub>pp</sub>. Thus, the 9V battery can be used to get approximately close to the desired output voltage. The output voltages from the battery were connected to the operational amplifier (op amp) in the oscillator section at pin 7 and 4 for the positive and negative voltages, respectively. The oscillator section uses several resistors, a capacitor, and an op amp to generate the square wave. The resistor that controls the frequency is R3. Using the equations below, we determined that a 3.3 kΩ (ohm) resistor would generate a frequency of about 100 kHz.

$$T = 2R_3C * \ln\left(\frac{1+\lambda}{1-\lambda}\right) \quad (1)$$

$$\lambda = \frac{R_5}{(R_5+R_6)} \quad (2)$$

Once the wave was generated, it was connected to a disposable electrode using snap wire leads. The second electrode was connected to a ground using the snap wire leads. Using these type of leads will ensure that there is a strong connection with the electrodes that will not accidentally fall off with daily activities while also allowing for easy replacement of the electrodes. The wires and electrodes will be fixed onto the neoprene rubber brace using VELCRO®. VELCRO® was chosen because it will keep the wires in place and allow for easy application of the device and because with it allows all electrical components to be removed from the neoprene brace so it can be washed regularly.

### **PERFORMANCE TESTING**

In testing the alpha prototype, we connected the device to an oscilloscope to receive visual confirmation of the voltage being output by the device. Once it was ensured that we obtained consistent voltages, we proceed with the construction of the beta unit. The power supply section and the oscillator section of the beta circuit were built separately first and tested with a voltmeter and an oscilloscope, respectively. Once the two sections were connected, the whole device was tested with an oscilloscope. The computational model showed the results of the electrical stimulation given by the prototype with an analysis of current and voltage distribution across multiple tissue layers.

### **FUTURE DIRECTIONS**

Future work on this could include, adding components to the device that have been shown to induce tissue growth. One option that can be explored is the addition of a heat component to promote blood flow to the stimulated area to enhance growth. In addition to heat, a timer component would be useful in this device since it is ideal that the electrical stimulation be applied only for a limited time. The timer can be used to turn on and off the electrical



impulses at a rate that is most effective. We would eventually move to a device that has the Arduino board completely enclosed with a user-friendly interface. The interface would provide the user with a way to adjust the voltage and frequency that is required for them since it is likely that these values will change for each patient depending on their size. Finally, the most important thing that must be done in the future is clinical studies to determine what the necessary values are for the voltage, frequency, and time of simulation to ensure the optimal results.

For improving upon this project in the future, advanced leg modeling using ANSYS or a related software would add to the accuracy of analysis. Obtained MRI images in Figures 11-12 can be imported into the computer modeling software to provide a physiologically accurate representation of a pediatric leg. This physiologically accurate computer model of electrical stimulation would be a great asset to the research team as they determine the optimal current for bone growth.

## References:

1. American Academy of Orthopedic Surgeons. (2007). *Limb Length Discrepancy*. Retrieved from <http://orthoinfo.aaos.org/topic.cfm?topic=a00259>
2. Weiner, Dennis, M.D. "First Meeting." Personal interview. Oct. 2015.
3. "FAQ." *Limb Lengthening*. Height Lengthening, 2016. Web. 01 Apr. 2016. <http://heightlengthening.com/faq/>.
4. Armstrong, Peter F., Brighton, Carl T., Star, Andrew M. "Capacitively Coupled Electrical Stimulation of Bovine Growth Plate Chondrocytes Grown in Pellet Form." *Journal of Orthopaedic Research*. 265-271 (1988)
5. Faes, T. J. et al. "The electric resistivity of human tissues (100 Hz-10 MHz): a meta-analysis of review studies." *Heethaar Physiol Meas*. 1999 November; 20(4): R1-10.
6. Brighton, Carl T. *Method for Non-invasive Electrical Stimulation of Epiphyseal Plate Growth*. Bioelectron, Inc., assignee. Patent US4467809 A. 28 Aug. 1984.
7. Griffin, M. et al. "Electrical Stimulation in Bone Healing: Critical Analysis by Evaluating Levels of Evidence." *Journal of Plastic Surgery*. (2011)
8. "Ilizarov External Fixator." *Ilizarov External Fixator*. Web. 26 Apr. 2016. <http://www.slideshare.net/mamunk56/ilizarov-external-fixator>
9. "External Electrical Bone Growth Stimulator Biomet® OrthoPak® Biomet." *External Electrical Bone Growth Stimulator*. N.p., n.d. Web. 26 Apr. 2016. <<http://www.medicaexpo.com/prod/biomet/product-74862-457284.html>>.

# APPENDICES

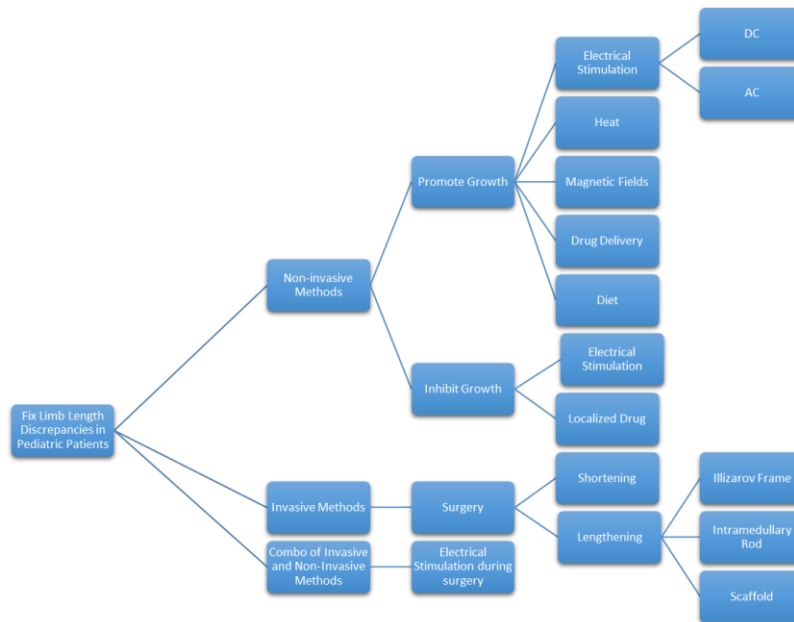

**Figure 1:** Brainstorming map showing the path/decisions made to create our final solution, taking into account all of the customer’s requirements and our own research and solutions.

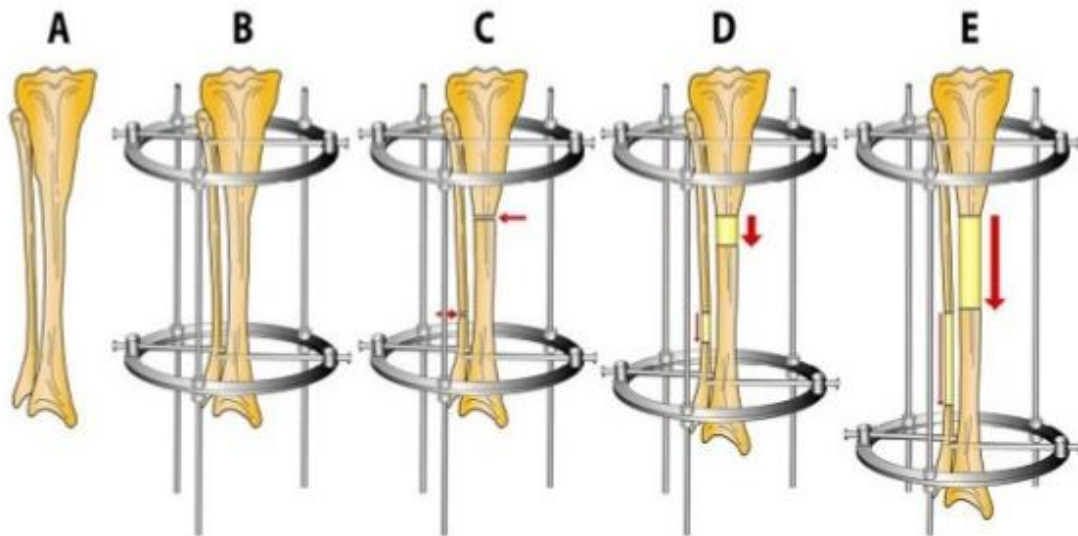

**Figure 2:** Ilizarov method for bone lengthening <sup>8</sup>. Images A-E represent the different stages of limb lengthening used in this method.



**Figure 3:** Biomet bone stimulator device<sup>9</sup>

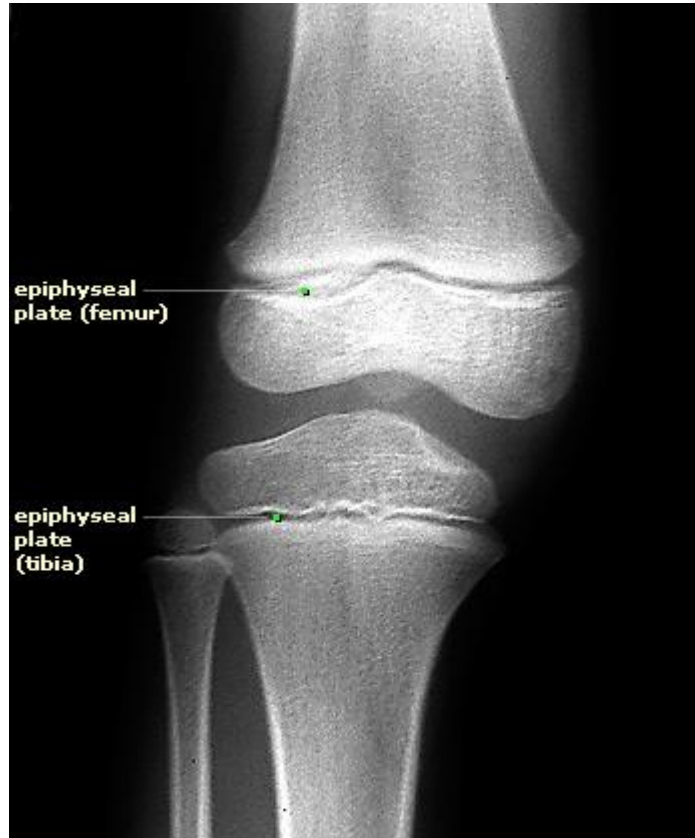

**Figure 4:** X-ray image of the epiphyseal plates in the knee

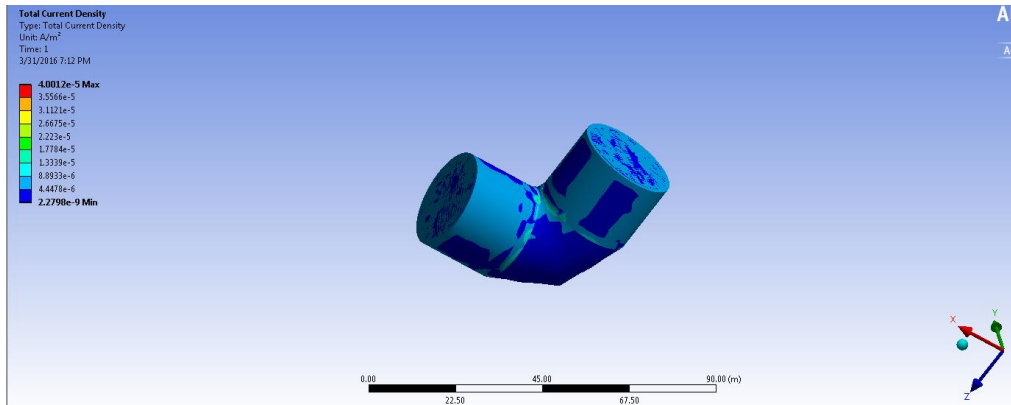

**Figure 5:** Leg-joint model stimulated by 10V at joint. Multiple layers of materials are present and able to be customized to fit the isotropic resistivities of human tissue.

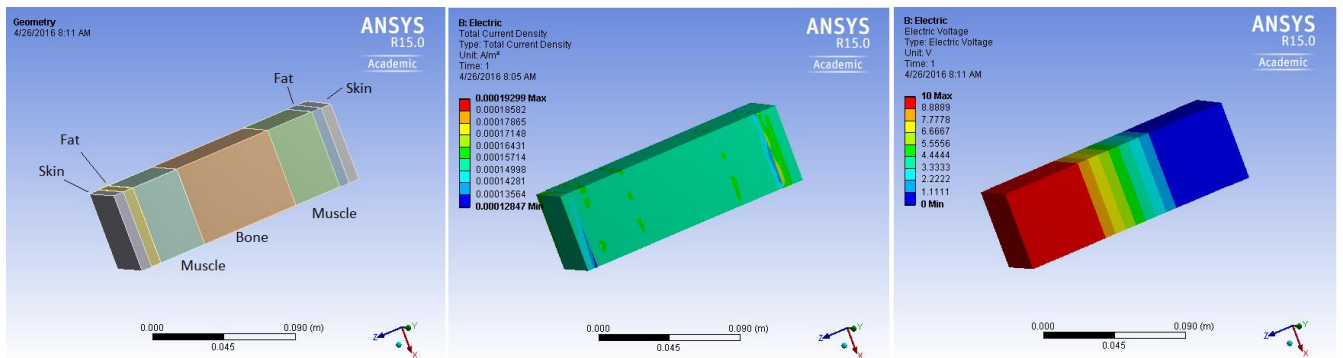

**Figure 6:** Left image shows geometry of scalable model. The center image shows the current distribution using two points of contact on the left and right end of the geometry. The right image shows the voltage drop with the same set-up.

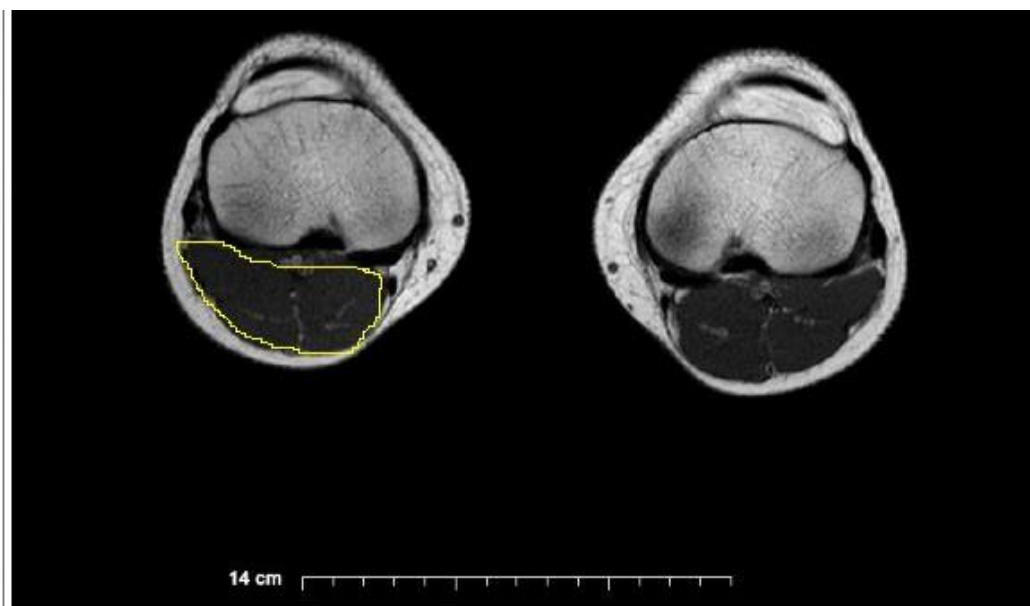
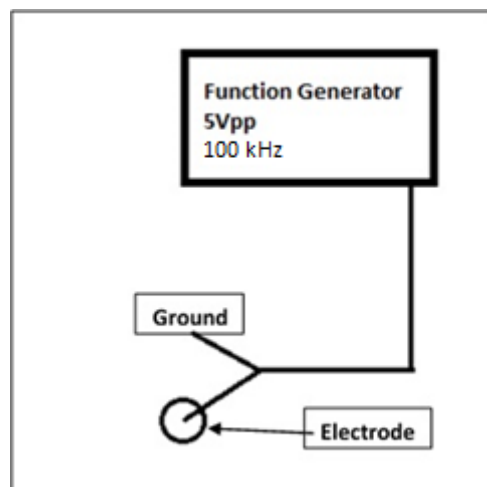

**Figure 7:** Transverse MRI at the knee of a 15 year old female. ImageJ was used to perform dimensional analysis.

**Table 1:** Milestones for ANSYS computational modeling with respective dates of completion.

1. Learn basic setup and electrical stimulation
2. Learn how to modify shape of material to include 90 degree angle like a knee
3. Customize the material to have resistivity properties similar to a specific tissue
4. Create a multilayered model
5. Create a multilayered model with resistivities similar to tissues
6. Use MRI image to gain approximate thickness and type of each tissue type and create in model

Task:	Completion date:
Learn basic setup and electrical stimulation	November 2015
Learn how to modify shape of material to include 90 degree angle like a knee	1/30/16 saved on flash drive and email
Customize the material to have resistivity properties similar to a specific tissue	4/12/16
Create a multilayered model	2/17/16 saved on computer
Create a model with the geometry of a knee with multiple layers that effectively show the effects of voltage application at a specific point	3/30/16 Saved on flash drive and email
Create a multilayered model with resistivities similar to tissues	4/18/16
Use MRI image to gain approximate thickness and type of each tissue type and create in model	



**Figure 8:** Alpha Prototype setup.

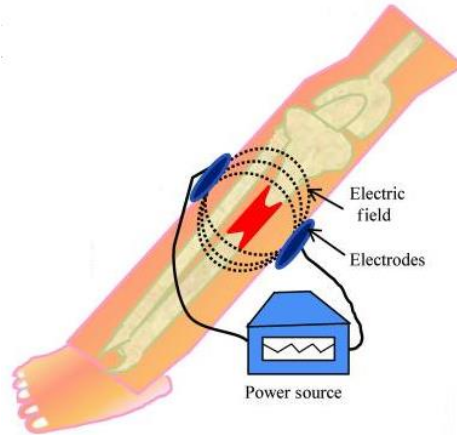

**Figure 9:** Sketch demonstrating the electric field induced by capacitive coupling using an AC signal<sup>7</sup>.

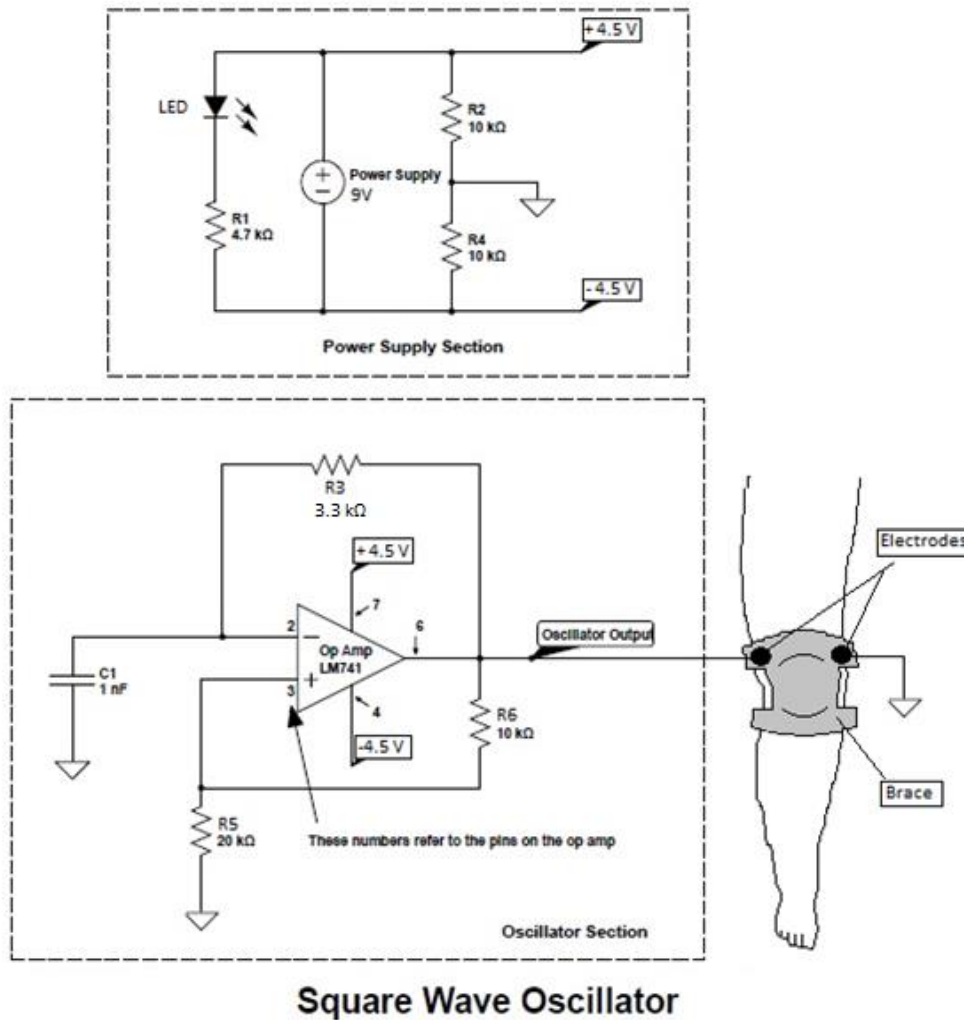

**Figure 10:** Square wave oscillator circuit schematic and sketch of the brace with electrodes on a leg.



**Figure 11:** Frontal view of lower legs.

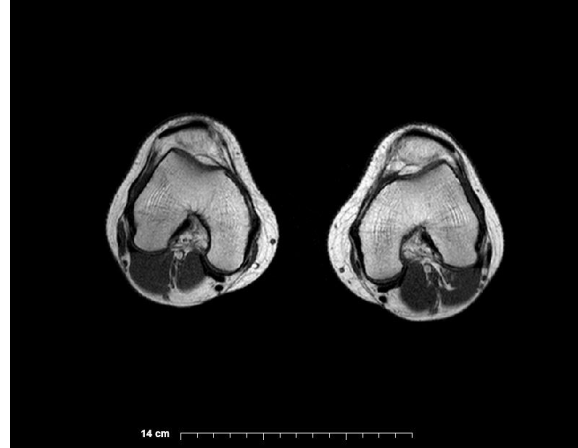

**Figure 12:** Transverse view at the knee joint.

## **FUNCTIONAL REQUIREMENTS**

The following list describes the requirements that are crucial in the creation of our device.

- **Non-Invasive:** Currently, there are surgical and invasive strategies to solve bone discrepancies such as plates, shortening, and the Ilizarov Method. A non-invasive device will set us apart from the competition while improving patient quality.
- **Electrical Stimulation:** This device must use electrical stimulation to solve bone discrepancy. Other methods were considered, but electrical stimulation seemed the simplest and most effective. We will use AC current to induce capacitive coupling as opposed to an electromagnetic field or DC current because it is the simplest method that can be externalized. In addition, this capacitive coupling method has been shown to induce bone growth in adults <sup>5,6</sup>.
- **Comfortable:** The purpose of this device is for it to be more comfortable for the children than current treatments. This will set us apart from the competition and improve the quality of life for the patient.



**Table 2:** All requirements laid forth by our customer, translated into engineering requirements (where applicable).

Customer Requirements	Engineering Requirements
Antibacterial	Detachable brace, able to wash and separate electrodes
Lightweight	<3 lbs.
Effective	~5V AC to DC. (verified by model)→5% longitudinal growth
Simplicity	<5 main parts to make up device
Low Cost	\$\$\$\$ (~\$100 device, surgery costs ~\$85,000)
Durability	Amount of force (N, psi, etc.)
Detachable	Removal Time <1 min.
Scalable	from peds to hamster (5 in-1 cm)
External	100% of device outside body
Controlled	Within range of (1-10V). Not to exceed to then cause harm to the patient
Hypoallergenic	N/A
No odor/handle moisture	N/A
Comfort	N/A
Aesthetically pleasing	0-10 scale; 75% approval from target market
Short application	<8 hrs. (When sleeping, ideal application time)

## CONSTRAINTS AND LIMITATIONS

- Financial
  - Balance of \$500.00 for the duration of this project
- Time
  - Project must be completed by beginning of May 2016
  - Balancing schedule of busy schedules of all students
  - After getting off on our project (too research oriented), needed to almost “start from scratch”
- Materials
  - Adhesion to skin
    - must not irritate skin (skin allergies to certain materials, more harm than good)
    - must be stationary to reduce rubbing
  - Electrodes
    - expensive - lower quantity available
    - Snap electrodes, ECG electrodes, muscle stimulation?
    - Permanently housed within the brace, removable? Sewn in, pocket, etc.
  - Modeling material

- solid
  - carry determinant current (minimal flux)
  - affordable
  - secondary model needs properties similar to human bone
- Knowledge
  - minimal knowledge of electricity by all members of team
  - little work experience in engineering
- Complexity of physical model to model in vivo
  - relate to how electrical stimulation occurs in complex anatomy of knee
- Modeling software
  - license for certain software only (such as ANSYS, MIMICS, etc.)

**TIMELINE**

The following are images of the Gantt charts that have been used throughout the year (Figures 13-14). The first shows what work was done during the Fall semester. The second shows what the current plan is for the rest of the Spring semester.

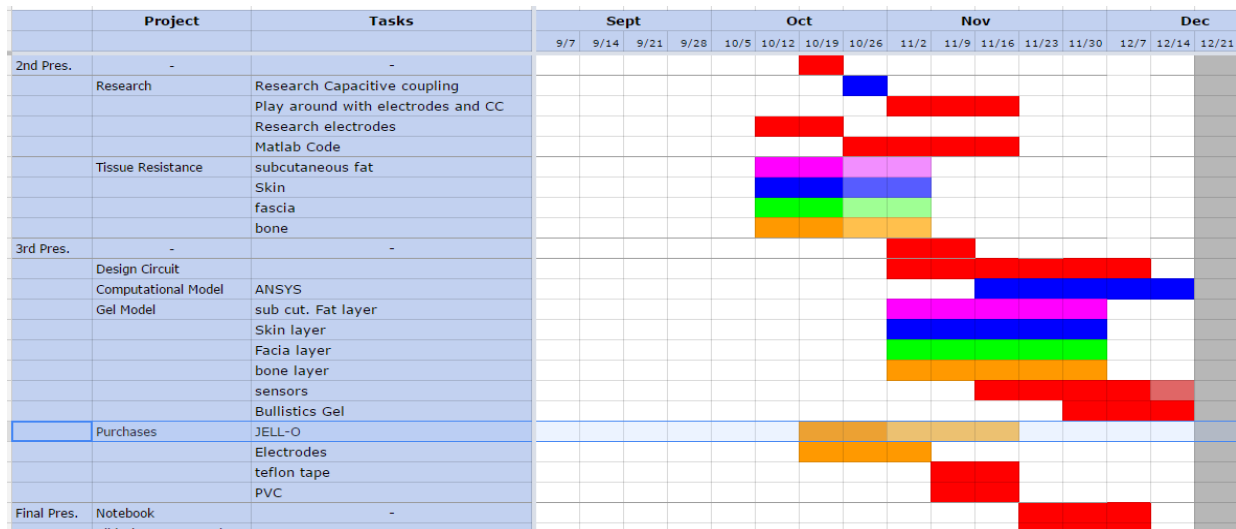

**Figure 13: Fall Semester Gantt Chart.**



**Table 4:** Breakdown of projected cost of final device components.

<b>Item</b>	<b>Cost</b>
Brace for attachment	\$22.50
ProtoBox Kit	\$14.00
Snap lead wires for electrodes	\$5.99
Electrodes	\$17.95
Resistors (3-10k's, 1-20k, 1-3.3k, 1-4.7k)	\$9.16
9V battery	\$1.95
1 nF Capacitor	\$0.25
Male Wire Connectors	\$2.98
Spool of Wire	\$16.00
Red LED	\$0.35
LD741 Op Amp	\$0.50