

## The University of Akron IdeaExchange@UAKron

---

Honors Research Projects

The Dr. Gary B. and Pamela S. Williams Honors  
College

---

Spring 2016

# THE UNIVERSITY OF AKRON NFPA 2015/ 2016 Chainless Challenge

Andrew Tupta

*University of Akron*, [art35@zips.uakron.edu](mailto:art35@zips.uakron.edu)

Andrew Ball

*University of Akron*, [ajb148@zips.uakron.edu](mailto:ajb148@zips.uakron.edu)

Stefan Stamboldziew

*University of Akron*, [ss245@zips.uakron.edu](mailto:ss245@zips.uakron.edu)

Jordon Spence

*University of Akron*, [jss69@zips.uakron.edu](mailto:jss69@zips.uakron.edu)

Sean Catchpole

[sgc12@zips.uakron.edu](mailto:sgc12@zips.uakron.edu)

Please take a moment to share how this work helps you [through this survey](#). Your feedback will be important as we plan further development of our repository.

Follow this and additional works at: [http://ideaexchange.uakron.edu/honors\\_research\\_projects](http://ideaexchange.uakron.edu/honors_research_projects)

 Part of the [Applied Mechanics Commons](#), and the [Other Mechanical Engineering Commons](#)

---

### Recommended Citation

Tupta, Andrew; Ball, Andrew; Stamboldziew, Stefan; Spence, Jordon; and Catchpole, Sean, "THE UNIVERSITY OF AKRON NFPA 2015/2016 Chainless Challenge" (2016). *Honors Research Projects*. 262.

[http://ideaexchange.uakron.edu/honors\\_research\\_projects/262](http://ideaexchange.uakron.edu/honors_research_projects/262)

This Honors Research Project is brought to you for free and open access by The Dr. Gary B. and Pamela S. Williams Honors College at IdeaExchange@UAKron, the institutional repository of The University of Akron in Akron, Ohio, USA. It has been accepted for inclusion in Honors Research Projects by an authorized administrator of IdeaExchange@UAKron. For more information, please contact [mjon@uakron.edu](mailto:mjon@uakron.edu), [uapress@uakron.edu](mailto:uapress@uakron.edu).



---

# THE UNIVERSITY OF AKRON NFPA 2015/2016 Chainless Challenge Project Report

---

(The Blue Roo)

**The University of Akron**  
302 East Buchtel Ave  
Akron, OH, 44325

April 2016

**Submitted by:** AJ Ball  
Andy Tupta  
Jordon Spence  
Sean Catchpole  
Stefan Stamboldziew

**Advisor:** Dr. Scott Sawyer

**RESTRICTED INFORMATION**

Any reference required by University





## Table of Contents

<b>1.0</b>	<b>EXECUTIVE SUMMARY .....</b>	<b>1</b>
<b>2.0</b>	<b>PROBLEM STATEMENT .....</b>	<b>2</b>
<b>3.0</b>	<b>OBJECTIVES .....</b>	<b>3</b>
<b>4.0</b>	<b>DESIGN ANALYSIS .....</b>	<b>4</b>
4.1	FRAME .....	4
4.2	PUMPS .....	4
4.3	ACCUMULATOR .....	5
4.4	GEARING .....	6
4.5	RESERVOIR.....	6
4.6	MOUNTING .....	6
<b>5.0</b>	<b>HYDRAULIC SYSTEM .....</b>	<b>8</b>
<b>6.0</b>	<b>DESIGN DRAWINGS .....</b>	<b>10</b>
<b>7.0</b>	<b>COMPONENT LIST .....</b>	<b>12</b>
<b>8.0</b>	<b>ACTUAL TEST DATA .....</b>	<b>14</b>
<b>9.0</b>	<b>COST ANALYSIS.....</b>	<b>16</b>
<b>10.0</b>	<b>LESSONS LEARNED .....</b>	<b>19</b>
<b>11.0</b>	<b>CONCLUSION.....</b>	<b>20</b>
<b>12.0</b>	<b>REFERENCES .....</b>	<b>21</b>





## 1.0 EXECUTIVE SUMMARY

Parker Hannifin has issued a challenge to student design teams of creating a Chainless bike using a hydraulic system. Each student design team will be assigned a technical advisor from the University. The project will be divided into two phases after the initial kickoff. The first phase will align with senior design course for motion control and hydraulics and will yield the student obtaining knowledge in hydraulics, including bio-degradable fluids, pneumatics, electromechanical systems, green technologies (sustainable energy) and controlling force and motion. Students will be provided data sheets, a list of in-stock Parker components and by the end of the first phase will be able to choose components. Additionally, mechanical drawings, fluid control circuits, and initial designs created for the vehicle will be required.

The second phase, upon midway review, is to be conducted with the NFPA/Parker review team virtually. The design will be evaluated for alterations from previous year's designs with consideration of new system, components, or frame. Points will be awarded based on the student team's delivery of Vehicle Design, Fluid Circuit Design, Selection of Hardware, Analysis such as fluid flow, expected performance, and dynamic, and Stage of Prototype build to date.

Finally, the third phase involves building and testing of the design vehicle by the student team. The final demonstration scheduled in April includes a sprint race, time trial race, efficiency challenge, and judging criteria will be the last phase. This Final demonstration will be held in California at The Great Park – Irvine California.

Moving along, technical requirements for the bike include several different aspects. A working vehicle must be build, operational, tested, and ready to compete in the judging and races in order to be allowed for travel and support to the final demonstration. There is not to be electric drive motor, internal combustion, or other modes of propulsion as vehicles must be human powered. To expand, the motive power can involve the following. Human assist, Hydraulic, pneumatic, with electronics. Also, ElectroHydraulic actuation or electro-hybrid is possible, subject to NFPA/Parker's decision. No chain or belt connection is allowed in the form of connection between freewheel cogs and the chain wheel. Additionally, vehicle design is to be single ride, with an optional number of wheels and open design style with regards to multi-wheel drive, recumbent, and standard. It is also encouraged that the bike incorporate energy storage devices as gas pre-charging systems will be available at the shipping/receiving location. At the start of each race, Hydraulic / Fluid Power Energy will be stored in the device. Finally, the bike must meet safe working limits of storage device and system components and must use bio-degradable fluid.





## 2.0 PROBLEM STATEMENT

Over the past 11 Scholastic years, Parker Hannifin has sponsored The Parker Chainless Challenge. This Challenge involves incorporating hydraulic components in order to replace the typical chain and gear system that's been used in bikes for many years. The competition spans multiple schools across the United States including Cal Poly San Luis Obispo, Cleveland State, Murray State, Purdue, U of Cincinnati, U of Illinois, UC Irvine, Kent State, U of Michigan, and U of Akron. Design teams from these schools build a knowledge base on the design of chainless vehicles and pass that knowledge on to the next group of students. Requiring that there be a significant change from the previous year's bike, vehicles vary from upright or recumbent, two and three wheel vehicles, to using pneumatics or hydraulic components. Often student teams conduct this project as a Senior Capstone design class, as is in our case. Utilizing resources we are to design a Human Assisted Fluid Powered Vehicle that will ultimately participate in the demonstration event which includes judging criterion, a straight sprint race, an efficiency challenge, and a time trial/endurance race.

Limited by the guidelines presented, our team set goals to meet for this project. Looking at the previous year design, we were required to change things up while obviously striving to improve upon design. Having a basic understanding of fluid concepts, this challenges students to learn more about hydraulic components and design. Consulting our advisor Dr. Scott Sawyer we were able to clarify the rules and regulations as well as realistic design options available to solve the problem presented when eliminating a chain from the typical bike configuration. We also are required to locate and acquire various parts if needed and not available from Parker. Learning about local shops and suppliers enables us to quickly acquire these additional parts. In summary, our team is challenged to innovate, improve, alter, design, build, test, and safely construct a human powered hydraulic vehicle.





### 3.0 OBJECTIVES

Objectives for The Parker Hannifin Chainless Challenge are two-fold. In regards to Parker, their objectives span several different topics. First, to stimulate education in pneumatics, sustainable energy devices, and hydraulics for motion control. Second, to provide students with experience under real world engineering applications involving a rigid timeline of designing, improving, analysis, ordering, assembling, troubleshooting, and demonstrating their designs. Thirdly, to arouse innovative reasoning for designing and implementing new ideas or potential new technologies integrated into a vehicle platform. Finally, to allow high potential engineering seniors a chance to network, learn and possibly be recruited into Industry.

In particular, objectives for The University of Akron's team this year were to lower weight by reducing weight of the frame, reduce weight in tire/rim, shred frame where possible, and make the system more compact. We were able to accomplish many of these, however these objectives changed from our original vision as a result of mistaken part order numbers and caused planned devices to be too far out, lead time wise, to use in our design. Therefore, our team quickly made decisions to ensure we would be able to compete in this year's event. Our new objectives became to alter last year's design using equipment available to us with a shortened lead time. Therefore, our design involved using two pumps. One hydraulic pump attached via gears to pedals in order to transfer energy from human powered input and another pump attached via gears to the back wheels of our bike to drive the bike. We want to use a tricycle style frame in order to vary our design from last year and also to allow for stability when maneuvering with heavy components such as the accumulator. More so, when mounting components we want to minimize bulk by customizing size according to components being mounted, as can be seen in our mounting schematics under the design drawings section of our report. Moving on, we shall discuss our design which incorporates these objectives.





## **4.0 DESIGN ANALYSIS**

To begin our initial design, our team set out to gather information that would help in the selection of the hydraulic system components. With the assistance of stationary exercise bike, we were able to gauge how much power was generated by the rider when pedaling the bike for ten minutes. The stationary bicycle was able to record the power generated in watts, which when converted to horsepower allowed our team to calculate the input torque that was being applied to the hydraulic system. When selecting our team analyzed the speed in revolutions per minute that the rider would be pedaling, as well as the volumetric flow through the system in cc/rev. From our calculations, our team was able to determine the gear ratios that would be needed for our system. Taking into account all of the calculations, we were able to select the pumps/motor required to carry out our design.

As previously mentioned, our team encountered some issues with incorrect part numbers in our order from Parker Hannifin, resulting in long lead times that did not allow us to proceed with our original design. As a result of these issues, our team needed to use existing components in order to achieve our original goal of constructing an operating hydraulic powered bike. This proved to be a challenge in our original goal, however our team was able to utilize other hydraulic components, which are described in more detail in the following sections.

### **4.1 FRAME**

We chose this frame mainly because of stability. Knowing that our component order was misplaced, we knew the design would need to incorporate innovate system with limited time and resources. Thus, we chose a frame which would utilize the tricycle layout for stability, balance and flexibility. Relying on a new frame would have placed an unneeded time constraint on our project/design ideas. The frame is where we started for our second design mockup after the setback. We knew the aluminum frame would be easy to work with, if the need arises, while withstanding any additional weight we may add to the bicycle. Our new design consisted of mounting the accumulator in the rear of the bicycle. With large amounts of weight located in the rear of the bike, the tricycle frame with two rear wheels was effective in maintaining stability and balance when operating the bike.

### **4.2 PUMPS**

Our original pumps were to be the Oildyne pump with 09 series hydraulic gear motor. These would have provided adequate power while shedding weight over previous years. However, with our product setback, we needed to use what was readily available to us in our lab. With that said, we settled on F11 small frame fixed displacement bent axis pumps. These pumps have the capability of handling our pressure load, both max and continuous operation, and were within range of our initial rpm range. Both of these help us improve the bicycle, but they also went against our objective of cutting weight.





The F11 series are much larger and heavier than the Oildyne pump and 09 series motor we originally planned on using. This gave us a great insight to design process, compromises. We decided that having more power was more important than the decrease in weight we would achieve with a different pump/motor combination.



*Figure 1: Pump/Motor Part Number*

#### **4.3 ACCUMULATOR**

Our initial design had contained the idea of a 4000 psi accumulator. This idea would allow us to tweak our initial pressure more, while still having the capacity to run and contain our system. We hit a stroke of luck when we discovered an identical accumulator that was used in a previous year. As you will see in our design drawings, the accumulator is placed directly above the back axle. This provided us with the heaviest component of our system being spread across the bike centerline and preventing it from adding large negative effects to our cornering.







*Figure 2: Accumulator Part Number*

#### **4.4 GEARING**

Connecting the crank to the pump is a 80 tooth gear meshed with a 24 tooth gear giving a gear ratio of 3.33. The motor output gear has 32 teeth and the drive axle gear has 80, giving a gear ratio of 0.4. The overall effective gear ratio considering the pumps is 1.33

#### **4.5 RESERVOIR**

Due to the setback with our part order, an oil tank could not be designed until a new overall system was established. Seeing where our team stood with time, we made the decision to reuse an older oil reservoir to reduce downtime of manufacturing and allowed us time to test the system before the due date. The oil tank we decided to use is a 1.5 gallon, stainless steel tank. The tank is relatively small, which allowed us to mount it between the bike seat and handle bars without encroaching on the riders comfort or ability to pedal the bike. This tank had the capacity we needed for our system and gave us convenience of a location that could not of been utilized by any other component of our system.

#### **4.6 MOUNTING**

We chose to mount our reservoir in the middle of the bike under our seat for several reasons. First of all, this position allowed us to utilize the area under the passenger bike seat without infringing on pedaling range of motion. The reservoir was not bulky or heavy and thus could be mounted custom to the area without concern for size, weight, or balance problems. Also, this would make it easily accessible to the tubing system having a high vantage point relatively in the middle of the system. A thin aluminum plate





was cut to the dimensions of the oil reservoir and mounted using various angle brackets. The brackets were bolted through the frame to provide stability and prevent the oil reservoir from potential rolling about when cornering.

Another key mounting our bike/system features is our accumulator location. The accumulator has been mounted above the back axle of the bicycle using thin steel beams and a plastic board the accumulator sits on. The beams are held in place with ninety degree angle brackets that are bolted through the bike frame. Identical brackets are then used to mount the beams and plastic board together. Finally, when the accumulator is in place, U bolts are used to prevent the accumulator from rolling about. This location provides us with adequate weight distribution when taking both the full oil tank and rider into account. It also adds more weight to the rear of the bike than originally expected, which helps provide traction to the inner rear wheel while cornering.

Other mounting included a small motorcycle battery that is simply held in place with Velcro. The motorcycle battery is located underneath the accumulator in “dead space” that could not have been used by anything else. Wiring from said battery has been fastened to the frame at various points on its way to both the solenoid valve and the toggle switch at the front of the bike.





## 5.0 HYDRAULIC SYSTEM

Our Hydraulic system is comprised of a mix of components. Focusing on using mainly mechanical devices, we incorporated (2) three-way ball valves (L-Port Configuration) for diverting flow, (1) check valve to prevent undesired flow through the pump wasting energy and creating a potential safety hazard for the driver, and (1) solenoid actuated poppet valve to allow for use of the charged up accumulator to power our bike. The effective hydraulic circuit is shown below, with the poppet valve replaced with a 2 way directional valve and a check valve, performing the same function as the solenoid actuated poppet valve.

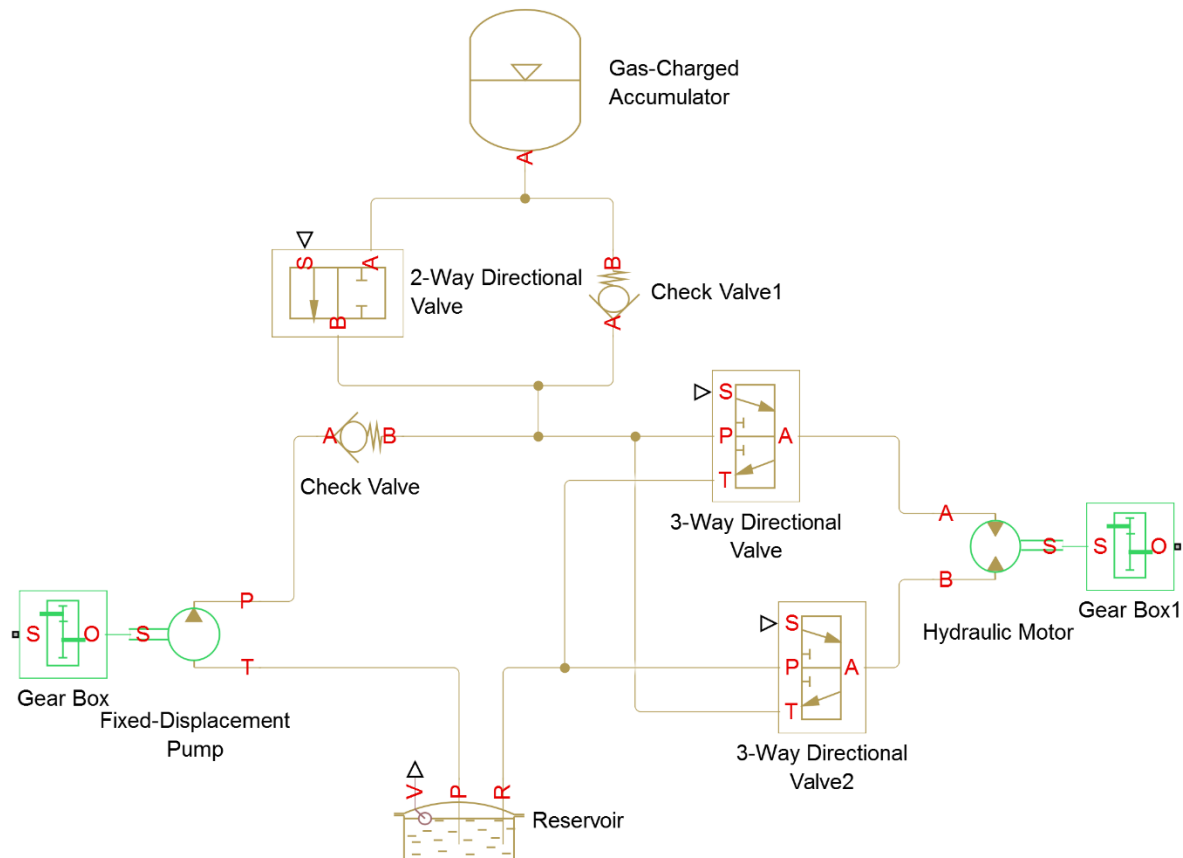

Our hydraulic system provides for 4 modes of operation: direct drive, Accumulator charging, accumulator drive, and regenerative braking. In direct drive, fluid is pumped from the reservoir to the pump/motor which is allowed to move freely. In charging mode, the brake is applied and the fluid is pumped into the accumulator as the pump/motor is not free to spin. In accumulator drive mode, the poppet valve is actuated allowing the stored fluid in the accumulator to be discharged through the pump/motor. The fluid is prevented from traveling through the pump by means of a check valve. In regenerative





braking mode, the 3 way valves are actuated, reversing the flow through the motor. In this mode, forward motion of the bike drives the pump/motor, charging the accumulator.





## 6.0 DESIGN DRAWINGS

As show below, we have several design drawings.

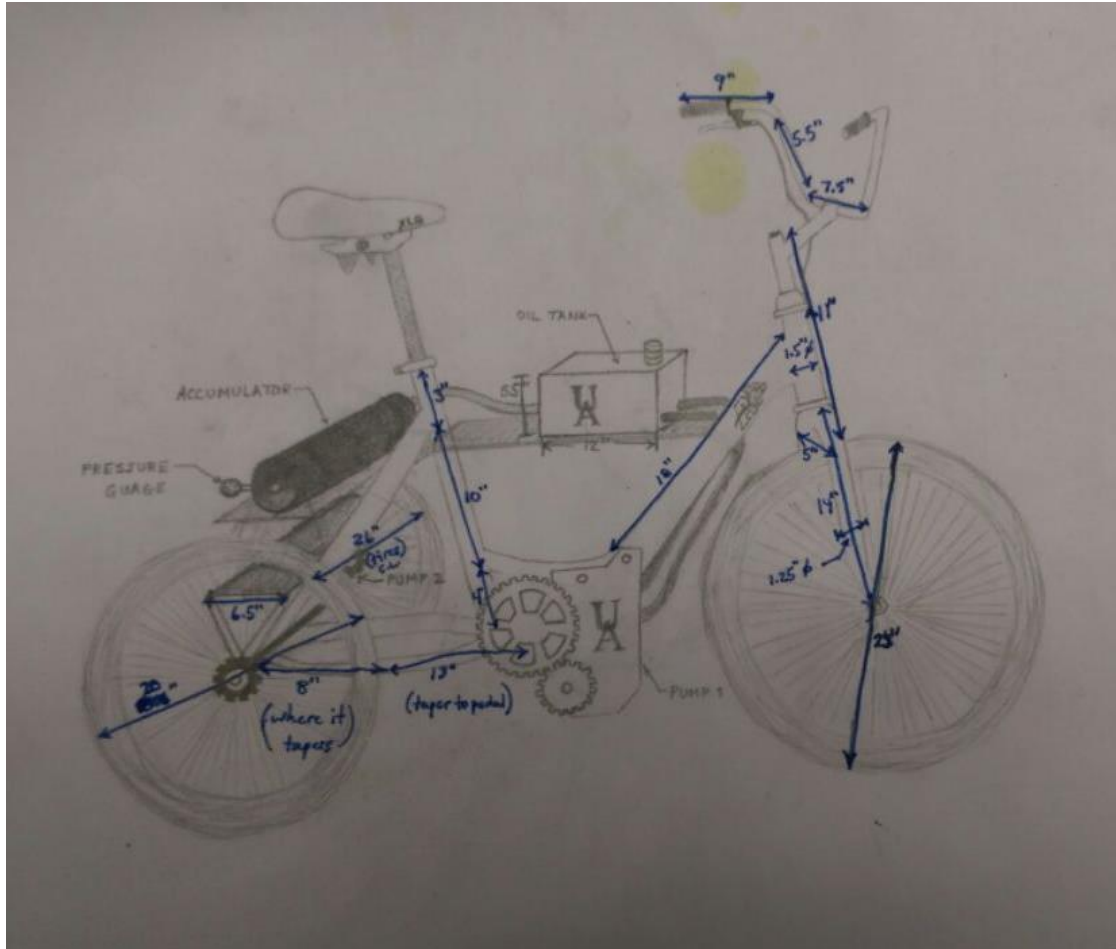

The above design drawing was our guide for designing and assembling the bike. This drawing was made while we still had a bare frame in order to generate mounting ideas and system space requirements.



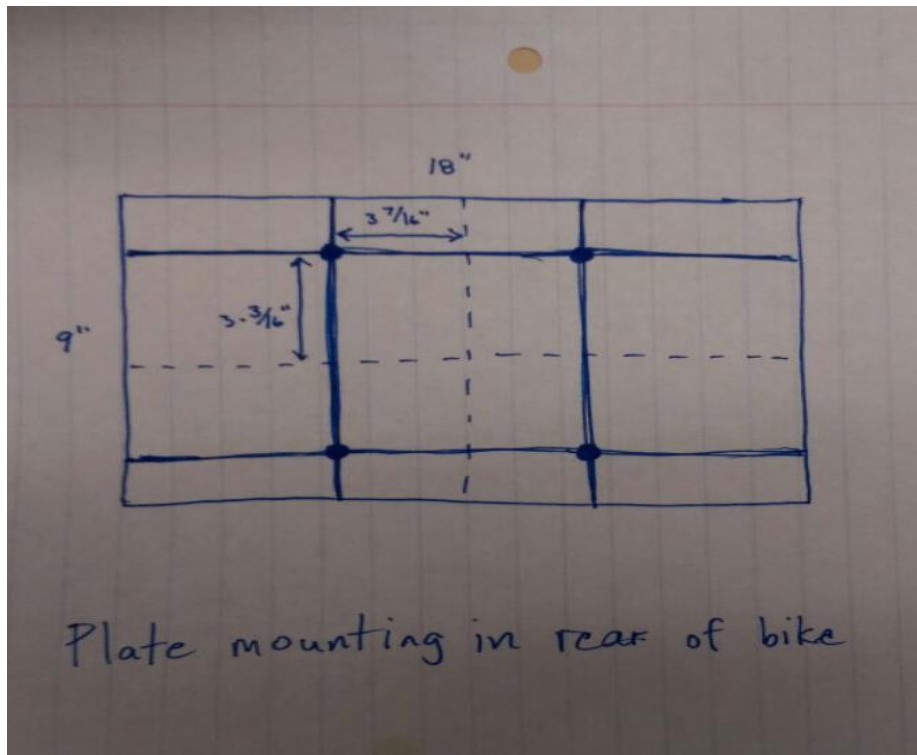

The above and below drawings were created in order to account for plate mounting in the rear of the bike, working with constrained areas.

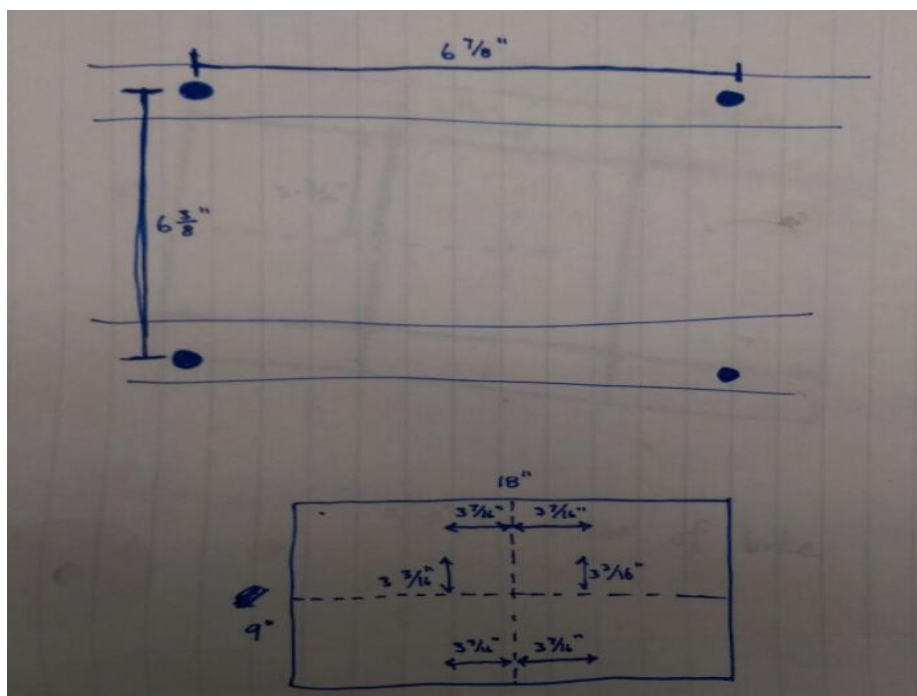



## 7.0 COMPONENT LIST

Listed in Table 1 below are the components used to mount the accumulator, oil reservoir, pump, and motor.

<b>Hardware &amp; Material Components</b>		
<b>Component</b>	<b>Description</b>	<b>Qty</b>
U- Bolts	3/8" - 16 threads, 6" deep, 5" across	
Plate	Multipurpose 6061 Aluminum, Sheet, .125" Thick, 18" X 18"	2
Angled Bracket	Strut Channel Accessory, 60 Degree Open Angle Bracket, 2-Hole, Zinc-Plated Steel	1
Angled Bracket	Strut Channel Accessory, 60 Degree Closed Angle Bracket, 2-Hole, Zinc-Plated Steel	1
Bracket	Strut Channel Accessory, 90 Degree Angle Bracket, 2-Hole, Zinc-Plated Steel	8
Old Bike Part	Plastic Platform Salvaged Off Old Bike	1
Wire	8' Electrical wire that charges the solenoid from the switch	1
Screws, Locking Nuts, Washers	Estimate of parts used from shop at the university	-

**Table 1: Hardware & Material Components**

In Table 2 below lists all the Bicycle Components we used.

<b>Bicycle Components</b>		
<b>Component</b>	<b>Description</b>	<b>Qty</b>
Bike	Tricycle	1
Battery	Battery Power Sport ATOC	1
Switch	Trail Tech electrical switch	1
Tire Tubes	Tube Brontrager 20X1	2
Shoes	GF Rumble VR	1
Pedals	Shimano PD-52	2
Tires	Odyssey Chase Hawk T	2

**Table 2: Bicycle Components**





The following table shows our drive cycle components.

<b>Drive Cycle Components</b>		
<b>Component</b>	<b>Description</b>	<b>Qty</b>
Reservoir	Stainless Steel hydraulic fluid reservoir	1

**Table 3: Bicycle Components**

The following table below consists of all the hydraulic components.

<b>Hydraulic Components</b>		
<b>Component</b>	<b>Description</b>	<b>Qty</b>
Pump	F11-005-HU-CV-K	2
Accumulator	ACP10AA300E1KTI	1
Pressure Gauge	Grainger Pressure Gauge - Liquid Filled, 2 1/2"	1
Hydraulic Fluid	5 gallon Mobile EAL 224H	1
Fill Cap	Nortrac Hydraulic Breather Cap 1" NPT	1
Solenoid	GS02 80/81 Poppet type, 2-way valve	1
Solenoid Coil	CCP012L Coil 19w - 12vdc - Double Lead	1
Check Valve	C800S	1
Female Pipe Tee	3/8 MMO-S	1
Straight Thread Connector	8-6 F50x - S	4
Male Connector	8 FBU-S	1
Male Connector	8-8 FTX - S	3
Male Connector	8 FTX - S	3
Union Tee	8 JTX-S	1
Black PHOS Plated Ferrule	8 TU-S	2
Connectors, Hoses, Tubing	Estimate of parts used from shop at the university	-

**Table 4: Hydraulic Components**







## 8.0 ACTUAL TEST DATA

### Test 1

After checking over our design and tightening all our connections we proceeded to fill our oil reservoir with oil. As we were filling the reservoir we were also pedaling to pump oil through the lines. We did this to make sure there would be enough oil in our bike for it to work. We then proceeded to pre-charge our accumulator. We calculated we would need to pre-charge the accumulator to around 120 psi. With help and supervision we were able to pre-charge the accumulator.



**Figure 3: Pre-charge accumulator**

We then poured additional oil into the oil reservoir and proceeded to our testing area. We made sure our testing site was clear and the rider wore a bicycle helmet and safety glasses. After pedaling we noticed a few slow leaks one from a T-valve and the other from the connection of the hose exiting the pump below the bicycle pedals. We quickly tightened these connections and continued testing. As the initial rider pedaled the bike proceeded to move. It moved fairly well on level ground, but struggled when faced with even a slight grade. We attributed this to poor tires and the pedals. We needed to find a way to generate more torque when pedaling to overcome a large force when pedaling upward.





## Test 2

Evaluating our bike's performance after Test 1 we decided our highest priority was to purchase new tires and pedals. Our old tires were almost a non-factor as the rims of the wheels were hitting the ground as the bike moved. We attributed this to either bad tubes or the weight of the accumulator and passenger was too heavy for the tires to overcome. We decided to purchase high pressure performance tires from a local bike shop. These tires not only were able to support the load required, but also reduced the rolling resistance of our bike making it faster and more efficient. Before our next test we also wanted to purchase new pedals. We needed to generate enough torque to overcome a large force that was preventing us from smoothly pedaling the bike. We decided to go with SPD Pedals or clip-less bike pedals. We purchased both pedals and shoes that lock into the pedal allowing us to generate more torque. After fitting our bike with the new purchases we were ready for Test 2. Upon pedaling we noticed the bike was easier to ride and performance was much improved. We were satisfied with our changes and results.





## 9.0 COST ANALYSIS

Taking the tables used in our component analysis section we were then able to do a cost analysis. Please note costs marked with an asterisk represent an estimated cost. Due to our parts not arriving on time we were forced to salvage old parts. In order to perform a cost analysis we estimated the cost of the old parts we used and did not have part numbers for.

<b>Hardware &amp; Material Components Cost Analysis</b>			
<b>Component</b>	<b>Description</b>	<b>QTY</b>	<b>Prototype Cost \$</b>
U- Bolts	3/8" - 16 threads, 6" deep, 5" across	2	6.72
Plate	Multipurpose 6061 Aluminum, Sheet, .125" Thick, 18" X 18"	2	114.24
Angled Bracket	Strut Channel Accessory, 60 Degree Open Angle Bracket, 2-Hole, Zinc-Plated Steel	1	8.28
Angled Bracket	Strut Channel Accessory, 60 Degree Closed Angle Bracket, 2-Hole, Zinc-Plated Steel	1	10.32
Bracket	Strut Channel Accessory, 90 Degree Angle Bracket, 2-Hole, Zinc-Plated Steel	8	8.72
Old Bike Part	Plastic Platform Salvaged Off Old Bike	1	-
Wire	8' Electrical wire that charges the solenoid from the switch	1	3.46
Screws, Locking Nuts, Washers	Estimate of parts used from shop at the university	-	100.00*
		<b>Total</b>	<b>\$251.74</b>

**Table 5: Hardware & Material Components Cost Analysis**





### Bicycle Components Cost Analysis

Component	Description	QTY	Prototype Cost \$
Bike	Tricycle	1	400.00*
Battery	Battery Power Sport ATOC	1	39.99
Switch	Trail Tech electrical switch	1	34.31
Tire Tubes	Tube Brontrager 20X1	2	17.98
Shoes	GF Rumble VR	1	80.00
Pedals	Shimano PD-52	2	44.99
Tires	Odyssey Chase Hawk T	2	53.98
		<b>Total</b>	<b>\$671.25</b>

*Table 6: Bicycle Components Cost Analysis*

### Drive Cycle Components Cost Analysis

Component	Description	QTY	Prototype Cost \$
Reservoir	Stainless Steel hydraulic fluid reservoir	1	945.00
		<b>Total</b>	<b>\$945.00</b>

*Table 7: Drive Cycle Components Cost Analysis*





Hydraulic Components Cost Analysis			
Component	Description	QTY	Prototype Cost \$
Pump	F11-005-HU-CV-K	2	850.00
Accumulator	ACP10AA300E1KTI	1	111.56
Pressure Gauge	Grainger Pressure Gauge - Liquid Filled, 2 1/2"	1	21.25
Hydraulic Fluid	5 gallon Mobile EAL 224H	1	117.25
Fill Cap	Nortrac Hydraulic Breather Cap 1" NPT	1	16.98
Solenoid	GS02 80/81 Poppet type, 2-way valve	1	150.47
Solenoid Coil	CCP012L Coil 19w - 12vdc - Double Lead	1	20.50
Check Valve	C800S	1	62.00
Female Pipe Tee	3/8 MMO-S	1	7.76
Straight Thread Connector	8-6 F50x - S	4	14.64
Male Connector	8 FBU-S	1	6.14
Male Connector	8-8 FTX - S	3	8.64
Male Connector	8 FTX - S	3	4.95
Union Tee	8 JTX-S	1	9.42
Black PHOS Plated Ferrule	8 TU-S	2	2.52
Connectors, Hoses, Tubing	Estimate of parts used from shop at the university	-	200.00*
		<b>Total</b>	<b>\$1504.08</b>

**Table 8: Hydraulic Components Cost Analysis**





## 10.0 LESSONS LEARNED

There were several different lessons we learned over the course of this project. Perhaps the most important was communication. There was a miss communication in terms of getting our parts ordered. We were aware of the deadline and assembled a list of the parts we needed. We sent the order, but did not follow up. A month later we learned our original order was never received and we would be hard pressed to get the parts we needed shipped on time to meet our build deadline. This was a large obstacle to overcome. Luckily, we had a room full of old parts used by previous design teams and decided to use these parts in order to meet our deadline and compete. We worked quickly to come up with a new hydraulic circuit and completely re-design our bike.

A lesson we learned during this project was time management. There were several due dates that crept up on us over the last few months. This project was extremely challenging because we started planning during one of the toughest semesters of school and we were all searching for jobs after we graduate this spring. It was often hard to find time to meet as we prepared for finals and career fairs. We were forced to effectively manage our time by using teamwork and other techniques. We were able to develop a time frame and despite setbacks we were still able to complete our project on time.

Another lesson we learned was teamwork. It is very important to work as a team especially when it involves large projects. From the start we were able to divide tasks based on skill sets and work as a team. After this project I am a firm believer in the old saying "two heads are better than one". As mentioned above we were faced with a huge set back when we found out our parts would close to our due date. We were able to get together and come with a plan to build our bike by the deadline. I firmly believe if we did not work together we would not have come close to getting our bike done on time. We were able to assign tasks based on each member's skill sets saving time, building the bike effectively and efficiently.

The final lesson we learned was hydraulic safety. The pressure the oil is under inside our bike is pretty significant and nothing to be taken lightly. Even the slightest of pressures can be problematic and should be handled with caution. When some of our group members were taking apart an old bike, oil began to leak out and made a giant mess all over our shop. We learned to loosen connections slowly and have a bucket in place at all times. We also learned to always check to make sure there is no pressure in our system. We used extreme caution throughout building and testing our bike. We also had supervision when appropriate.





## 11.0 CONCLUSION

In conclusion, we were able to successfully develop a hydraulic powered bike. In order to do this, we took various steps involving the engineering design process. To begin the design process, we analyzed input torque and gear ratios needed for the pumps to operate as efficiently. Our calculations allowed us to select pumps that would allow our bicycle to operate in the various modes, direct drive, charging, and regenerative braking.

As happens in the real world, our group encountered several unexpected disturbances that forced us to adapt. These issues challenged our team to rethink our original design in order to still achieve our goals in a timely fashion. Taking these into consideration, our design from initial conceptualization to final completion varied drastically. Rather than using the design that we initially intended, existing hydraulic components needed to be used. Although it was very unfortunate that challenges occurred during the engineering design process, our team was able to adapt quickly in order to still produce an operating hydraulic bike.

When comparing our chainless hydraulic bicycle to standard chain and gear bicycles that are more commonly used, it can be seen that the hydraulic design is much bulkier and harder to operate. The weight of the hydraulic bike is much greater than that of a standard chain driven bike, making it a tough sell to consumers in search of bicycle. Despite certain obstacles that were encountered during the process, each of our team members now has a much greater understanding of hydraulic systems and how they operate. Additionally, we were able to learn that in the field of engineering the design process does not always go smoothly throughout. There will always exist obstacles, but the important thing is dealing with the adversity in order to still meet the deadline or goal at hand.





## 12.0 REFERENCES

"F11 Small Frame Fixed Displacement Bent Axis Truck Pumps and Motors | Parker NA." *F11 Small Frame Fixed Displacement Bent Axis Truck Pumps and Motors | Parker NA*. N.p., n.d. Web. 26 Mar. 2016.

"ACP NON REPAIRABLE HYDRAULIC PISTON ACCUMULATORS | Parker NA." *ACP NON REPAIRABLE HYDRAULIC PISTON ACCUMULATORS | Parker NA*. N.p., n.d. Web. 26 Mar. 2016.

