

JOTE

Journal of Occupational
Therapy Education

Volume 3 | Issue 1

Educational
Innovations

Article 11

2019

Design of an OSCE to Assess Clinical Competence of Occupational Therapy Students

Nancy E. Krusen
Pacific University

Debra Rollins

Follow this and additional works at: <https://encompass.eku.edu/jote>

 Part of the [Educational Assessment, Evaluation, and Research Commons](#), and the [Occupational Therapy Commons](#)

Recommended Citation

Krusen, N. E., & Rollins, D. (2019). Design of an OSCE to Assess Clinical Competence of Occupational Therapy Students. *Journal of Occupational Therapy Education*, 3 (1). <https://doi.org/10.26681/jote.2019.030111>

This Educational Innovations is brought to you for free and open access by Encompass. It has been accepted for inclusion in Journal of Occupational Therapy Education by an authorized editor of Encompass. For more information, please contact Linda.Sizemore@eku.edu.

Design of an OSCE to Assess Clinical Competence of Occupational Therapy Students

Abstract

Objective structured clinical examinations (OSCEs) are a series of controlled, timed stations in which students demonstrate clinical skills. OSCEs are commonly used within health professions education to demonstrate competence, prepare for clinical education, and conduct program evaluation. The body of literature addressing the use of OSCEs in occupational therapy (OT) is growing; however, there are no available guidelines for developing an OSCE specific to the profession. The purpose of this paper is to describe the design of an OSCE for OT students prior to fieldwork placement. Twelve OT practitioners participated in a modified-Delphi method to generate possible OSCE scenarios. The authors developed a blueprint, designed items, implemented an OSCE, and collected data. Quantitative analysis suggests OSCEs to be valid assessment of clinical skills. Qualitative analysis suggests students perceive OSCEs to be stressful but valuable learning experiences. The authors are conducting additional analysis of outcome data, exploring the utility of OSCEs as a strategy to assess clinical competence in OT. Stakeholders concurred with the need to investigate the experience of learning through doing. The authors believe OSCEs could address universal professional rather than program specific clinical competencies.

Keywords

Clinical competence, objective structured clinical examination (OSCE), assessment, learning

Creative Commons License



This work is licensed under a [Creative Commons Attribution-Noncommercial-No Derivative Works 4.0 License](https://creativecommons.org/licenses/by-nc-nd/4.0/).

JOTE

Journal of Occupational
Therapy Education

Volume 3, Issue 1

Design of an OSCE to Assess Clinical Competence of Occupational Therapy Students

Nancy Krusen, PhD, OTR/L and Debra Rollins OTD, OTR/L

Pacific University

United States

ABSTRACT

Objective structured clinical examinations (OSCEs) are a series of controlled, timed stations in which students demonstrate clinical skills. OSCEs are commonly used within health professions education to demonstrate competence, prepare for clinical education, and conduct program evaluation. The body of literature addressing the use of OSCEs in occupational therapy (OT) is growing; however, there are no available guidelines for developing an OSCE specific to the profession. The purpose of this paper is to describe the design of an OSCE for OT students prior to fieldwork placement. Twelve OT practitioners participated in a modified-Delphi method to generate possible OSCE scenarios. The authors developed a blueprint, designed items, implemented an OSCE, and collected data. Quantitative analysis suggests OSCEs to be valid assessment of clinical skills. Qualitative analysis suggests students perceive OSCEs to be stressful but valuable learning experiences. The authors are conducting additional analysis of outcome data, exploring the utility of OSCEs as a strategy to assess clinical competence in OT. Stakeholders concurred with the need to investigate the experience of learning through doing. The authors believe OSCEs could address universal professional rather than program specific clinical competencies.

INTRODUCTION

Educators in health professions are challenged to accurately assess skills as students progress from academic performance to competence in practice. Objective structured clinical examinations (OSCE) are a series of controlled, timed stations in which students demonstrate specific clinical skills. The body of literature addressing the use of OSCEs in occupational therapy (OT) is growing; however, there are no available guidelines for developing an OSCE specific to the profession. The purpose of the paper is to describe the design of an OSCE to assess clinical competence of OT students prior to fieldwork placement. The authors generated scenarios, developed a blueprint, implemented an

OSCE, and collected data. Outcome data were analyzed to examine effectiveness of the process, currently under review for publication in a separate work.

Harden, Stevenson, Downie, and Wilson (1975) were the first to propose OSCEs as a means to assess clinical competence in medicine. They specified marking criteria in advance of examination to improve rater objectivity. The authors posited that OSCE results offer different feedback to students and faculty than was achieved via examination or case study. Since that time, many authors have explored OSCEs as an alternative to traditional multiple-choice didactic tests or conventional clinical examination. Miller (1990) described a model of performance assessment recognizing sequential acquisition of clinical competence – knows, knows how, shows how, does. OSCEs require students to *show how*, to perform clinical skills in a simulated environment. OSCEs are now a commonly used performance assessment within schools of medicine, nursing, dentistry, pharmacy, physical education, speech-language pathology, physical therapy (PT), and social work (Awaisu, Abd Rahman, Nik Mohamed, Bux Rahman Bux, & Mohamed Nazar, 2010; Farahat, Javaherian-Dysinger, Rice, Schneider, Daher, & Heine, 2016; McWilliam & Botwinski, 2010; Walsh, Bailey, & Koren, 2009).

OSCEs typically assess a variety of cognitive, affective, and psychomotor skills through a series of short stations simulating a variety of clinical scenarios. OSCEs require students to recall theory and process, applying specific behaviors to unique circumstances. Stations may be question or procedural (Harden & Gleeson, 1979). Question stations are typically unobserved, requiring reading, interpretation of data, and a written response. Procedural stations are observed, requiring examiner-monitored performance of a skill. Areas assessed are tailored to suit the curriculum and outcomes of the school or program in which students are enrolled (Khan, Gaunt, Ramachandran, & Pushkar, 2013). Stations may be technology-enhanced, using computers, video recording or human patient manikins. Two or more stations based on the same scenario are referred to as linked, and may be observed or unobserved.

Edwards and Martin (1989) were the first to report application of OSCEs in OT. They posited OSCEs to be valuable for summative and formative student assessment, based on their implementation. They recommended continued research to establish reliability and validity, as well as development of an OT OSCE bank of questions to decrease the length of time needed for design. O'Brien and McNeil (2013) examined effectiveness of two teaching methods in OT student preparation for clinical practice, Integrated Performance Procedure Instrument (IPPI), describing a written case study assessing clinical reasoning, and OSCEs. The authors examined scores from each of these methods in relationship to the American Occupational Therapy Association (AOTA, 2002) Fieldwork Performance Evaluation (FWPE). IPPI cases supported integration of content across courses. OSCEs supported practice of performance skills. The authors found a significant correlation between the IPPI and FWPE scores. They did not find significant correlations between OSCEs and IPPI, or between OSCEs and FWPE scores. It is possible that each assesses a different construct. Authors concluded IPPI

and OSCE measures were useful in assessing practice skills, recommending more comprehensive and structured OSCEs for students prior to their Level II fieldwork.

A group of educators in Japan have written extensively about an OSCE-compliant education system for OT and PT students. Sakurai et al. (2013a) described the implementation of OSCE examination of therapists, with subsequent comparison of performance across several graduating classes of entry-level OT and PT practitioners. Authors reported variable results across psychomotor, emotional, and cognitive domains of learning for students in all cohorts. Sakurai et al. (2013b) reported no significant correlation between OSCE performance and clinical education. Authors recommended additional investigation of the bridge between academic and clinical education related to OSCEs. Sakurai et al. (2014) studied interrater reliability between (OT and PT) faculty members and clinical supervisors who served as OSCE examiners. In general, interrater reliability was low across technical skills, with high agreement across behavioral skills. Authors recommended clear criteria for OSCE items to accommodate for differences in examiner background. This body of work is combined with PT students, with the utility of OSCEs for the profession of OT remaining unclear.

During a conference for teaching and learning, Moliner (2016) presented a template to develop OSCE scenarios specific to OT students, designing stations corresponding primarily with the Canadian Practice Process Framework (Townsend & Polatajko, 2007). Moliner examined correlations between a comprehensive integrative OSCE (CI-OSCE), a reflective essay, grade point average, and fieldwork. The author found a moderate correlation between CI-OSCE and fieldwork, suggesting the OSCE may provide useful opportunities for student learning. Rowe (2015) designed and implemented an OSCE of interpersonal communication skills with first year OT students. Practitioners and educators recommended baseline interpersonal communication skills through focus groups. Descriptive statistics revealed first year students rated the process as helpful or very helpful: OSCE (98%), reflection (100%), staff feedback (98%), and reflective assignment (93%). While there is a growing body of literature describing the usefulness of OSCEs in OT education, there is a paucity of information detailing the process of creating an OSCE specific to the profession.

METHODS

Faculty within a School of Occupational Therapy in the Pacific Northwest have used a variety of assessments for clinical competence for the entry level OT doctorate (OTD) students, including skill-specific lab checkouts and extended, 30-minute simulated patient clinical examination (SPACE) cases. Lab checkouts target building blocks, such as transfers, splint-making, or standardized assessments. SPACE cases facilitate professional reasoning through intervention with mock clients. The lengthier SPACE cases enable relationship building and longer engagement than 5-minute standard OSCE rotations. Faculty expressed an interest in a performance-based measure of clinical competence prior to clinical placement. All agreed to a trial of short, multi-station OSCEs with two primary aims. The first aim was to provide an assessment of clinical competencies prior to students' departure for Level II fieldwork. The second aim was to provide information for program evaluation.

Design

Faculty grounded the OSCE in transformative learning (Mezirow, 1981), through which students transform old knowledge by reflecting on new experiences, and in situated learning (Lave & Wenger, 1991), a just-right challenge embedded within task, context, and practice culture. Two core team members, the authors, took on the primary role of OSCE developers. They implemented a modified Delphi process including faculty members and community practitioners as vested expert stakeholders. A Delphi process is one in which experts contribute opinions, reaching a consensus through iterative collaboration. An initial solicitation across twelve expert stakeholders generated 32 potential scenarios. Stakeholders scrutinized the scenario pool from several perspectives including program outcomes, practice setting, age range, diagnostic category, and complexity of skills (low, mid, high) related to Bloom's taxonomy – cognitive (Cog), psychomotor (PM), and affective (Aff) domains (see Table 1). Stakeholder consensus eliminated duplicates and the impractical, agreeing on 24 possible scenarios. Stakeholders also agreed that the focus of the OSCEs be directed toward complex scenarios requiring skill in all three taxonomic domains. Stakeholders believed cognitive skills to be well assessed through course assignments such as quizzes, exams, and written papers. They also believed psychomotor skills to be well assessed through current lab checkouts and extended SPACE cases.

Organization

Following lengthy discussion, stakeholders concurred that OSCE scenarios be organized according to competence areas matching those of the AOTA FWPE. The FWPE is an instrument intended to measure entry-level competence of OT students during clinical placement experiences. OSCE stations represented a broad range of competencies across each of the FWPE categories. Stations included four items each in Evaluation and Intervention, two items each in Fundamentals, Management, Communication, and Professional, and one item in Basics. The authors believed traditional, short-rotation OSCEs supported assessment of many students within a short period of time to address a variety of skills necessary in current practice. The authors created an initial blueprint (see Table 1) of OSCE stations inclusive of skill level, practice setting, client age, focus of OT intervention, and FWPE competence area. The authors added columns for manpower and materials needed as planning progressed. Authors also noted whether a station was linked (e.g. A Link B) with its corresponding letter.

Table 1

Example of OSCE Blueprint

Station	Area of Practice	Setting	Age	Scenario Description FWPE skill #	Domain	Rater/ Materials
H	INTERV	Outpt	Peds	Locate mobile/computer app for client (meds, bus schedule, alarm) [24 modifies task approach, occupation, and the environment]	Cog-mid PM-mid	Computer
G	MGMT NO START	Any	Any	Oral summary report to OTA (known and competent); [27 demonstrates through practice or discussion the ability to assign. (28 demonstrates through practice or discussion the ability to actively collaborate)]	Cog-mid PM-mid	G Link F Computer
Q	MGMT	SNF	Elder	SNF RUG levels [29 Understands costs & funding]	Cog-low	
K	COMM	SNF or Rehab	Elder	Client with aphasia [32 Clearly and effectively communicates verbally and nonverbally]	Aff-high Cog-mid	Rater
I	COMM	Any	Any	Teach family locate, install, use a mobile or computer app [32 Clearly and effectively communicates verbally and nonverbally]	Aff-mid Cog-mid PM-mid	Rater Computer

Note: INTER = intervention; COMM = communication; MGMT = management; SNF = skilled nursing facility

Stakeholder Preparation

The authors co-taught a course targeting preparation of second year students (OTD2) for Level II fieldwork, including OSCEs. The course included an interactive session addressing improvisation in practice. Students engaged in improvisation scenarios supporting development of critical thinking as an adaptive skill. The authors encouraged students to generate potential solutions for unpredictable daily practice (Krusen, 2012). Course participants also reviewed standard professional behaviors needed for any client interaction, and therefore for each OSCE station. These behaviors included greeting the patient, introducing oneself, using layman's language, including a teach-back, and responding to questions.

Students completed one training OSCE during the course, practicing the five-minute/one-minute standard rotation pattern. Students had opportunities to take on roles of student practitioner, simulated patient, rater, family member, and observer. Authors posted to the course learning management system a written overview of

OSCEs, practice templates with station objectives, instructions, and tasks. Instructions included Miller's triangle (1990), rating checklists, global scores, role of the examiner, tips, and an emergency plan. Authors provided an individualized rotation schedule and map of the scenario locations to each of 40 students. The rotation schedule also included individualized accommodations identified through learning support services. While the team considered using an audible alarm, we did not do so, needing to accommodate participants with auditory or other learning concerns.

Faculty and community practitioner raters also received a written overview of the OSCE, Miller's triangle (1990), checklist, and role clarification. A member of the development team reviewed the written overview with each rater, setting up raters at their stations. All stations were cleared of clutter and pre-set with tools and materials. Raters received a copy of the station template and copies of rating sheets for each student. Students received numeric codes for identifier-free rating sheets.

OSCE Procedure

Following recommendations noted by Harden and colleagues (Harden et al., 1975; Harden et al., 1979), the team designed 17 OSCE rotations of five minutes each followed by a one-minute transition (see Figure 1.). The team scheduled two sessions of 20 students each, including three rest breaks during rotations. Students began at different stations in the circuit at specified times. After five minutes, students moved to the next station, with one minute to travel and read the posted instructions. Experts (faculty and community practitioners) served in dual roles as simulated patients and as raters. Raters did not change stations, rating the performance of each student in the cohort. Raters completed checklists and comments during the one-minute rest.

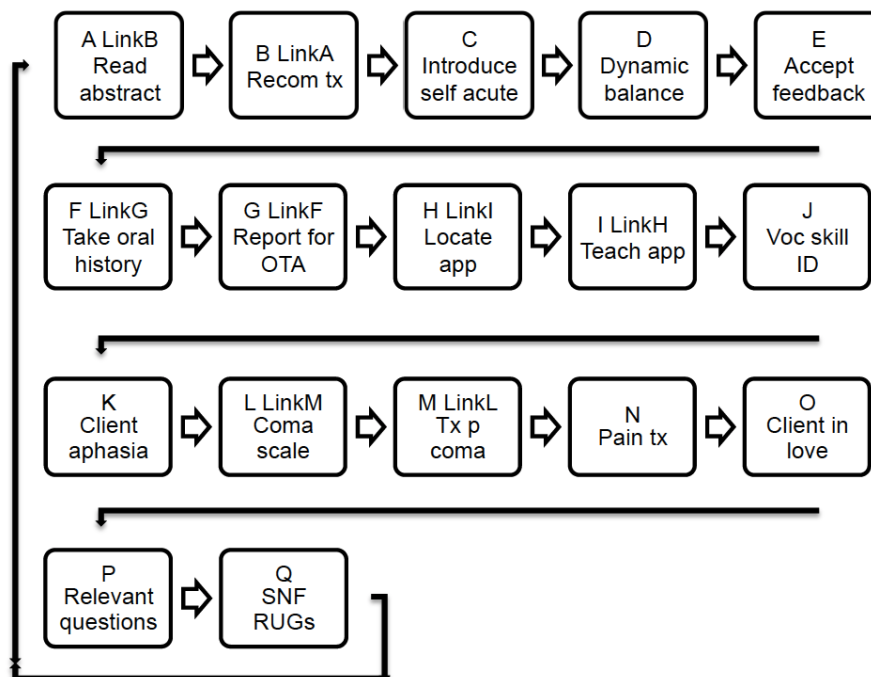

Figure 1. Sample OSCE rotation.

Checklist and Global Rating

The authors developed a template for station prompts. For each station, a prompt described the assessment objective, instructions in two to four sentences, student task in two to four sentences, and whether the station was observed or unobserved. Expert contributors reviewed prompts for final agreement. Experts created criterion-based checklists with the respective expert contributor, identifying specific behaviors a student could be expected to demonstrate. Specific behaviors for each station ranged in number from four to ten. Experts identified some behaviors as mandatory to pass, with other behaviors as recommended to pass. The numbers of behaviors, and thus the length of the checklist, was contingent on the task. Raters marked the corresponding item on the checklist if a behavior was seen, or left the area(s) blank if a behavior was not seen (see Figure 2, Sample rating sheet). Stakeholders did not expect nor require completion of all behaviors to pass the station. Raters completed a behavioral checklist for each student's performance at a station, followed by completion of a Global Rating Scale (Centre for Medical Education, Queen's University at Belfast, 2012). Global scales are holistic rather than reductionistic, giving a broad view of overall performance in comparison to a rating scale of interactive fragments. The Queen's University Global Scale ratings include excellent, very good pass, clear pass, borderline pass, and clear fail. Raters were asked to consider what skill level would be expected of a student at the entrance to Level II fieldwork. Global scales are valuable for determining the quality of the performance. Checklist scores and global scales for each station/task were independent of each other.

<p>Assessment objective of OSCE station: D/C environment post-CVA Candidate instructions: Patient post (L) CVA in skilled nursing setting. Discharge planned in the next few days. You are providing weekend coverage. You and patient are not known to each other. Chart review and physical therapist relate upper extremity & lower extremity movement out of synergy. Patient has expressive aphasia. Task: Interview the patient re home environment to make recommendations for discharge.</p>	
<p>Checklist Score Rating 0-10</p>	<p>Performed correctly</p>
Introduces self	
Greets patient	
Identifies purpose of the session	
Asks questions pertaining to home environment	
Recognizes patient's growing concern; attends to body language	
Seeks alternate means of communication	
Seeks reliability of response	
Stops questions pertaining to home environment	
Attempts to uncover source of patient's distress	
Discovers source of patient's distress	
Attends to safety: ascertains swallowing capability, mobility	
Gets water for client	
Accolades:	Recommendations:

Figure 2. Sample rating sheet.

Data Collection

The authors collected data from several sources. The authors collected quantitative data from behavioral checklist scores and global scores for each student at each station. They also collected student perceptions of the OSCE through a 14-item self-administered survey. The survey included 11 scaled quantitative items evaluating the structure and content of OSCEs and three open-ended qualitative items including strengths, recommendations, and comments. The University Institutional Review board deemed the study exempt, as data were deidentified and archival from routine course evaluation (#1298488-1).

Data Analysis

Authors analyzed quantitative survey and behavioral checklist scores using Excel and Social Science Statistics calculators. The authors applied descriptive statistics to scaled survey items. Authors applied Spearman's rho correlation to behavioral checklist scores, examining multiple relationships between average scores for each station, average scores for station categories, and average score for the OSCE as a whole. Four OT practitioners, including the authors, conducted qualitative analysis through independently coded responses to open-ended survey responses using word processing and HyperRESEARCH software. Line-by-line content analysis supported collaborative development of overall themes.

RESULTS

The primary purpose of this paper was to describe the development of OSCEs to assess clinical competence in OT students prior to fieldwork placement. Results of student performance and perception are summarized below. More detailed quantitative and qualitative data analysis is under review for publication. A total of 40 students (in sequential sections of 20 each) completed 17 OSCEs with three rest stations for a total of 800 stations within six hours. Eight faculty and community practitioners served dual roles as raters and mock patients. Each rater held completed score sheets until the end of the sessions, returning them to the team or administrative staff. The authors scored unattended stations when all OSCE circuits were complete.

Performance

The authors compiled individual behavioral checklist and global scores. Student raw score totals ($n=40$) ranged from 66-92 ($x = 78$, $SD = 6.27$). The authors calculated average scores for each station as well as average scores for each station category: fundamentals, basic, evaluation, intervention, management, communication, and professional. Of the 17 stations, authors analyzed data for 14. Stations G and L were not included in analysis due to problems with participant-technology interface. Data for station H was also excluded from calculation as the raw all-or-none score was not discriminating of behavior. Authors calculated Spearman's rho for multiple relationships, between station-specific averages, category averages, and overall OSCE scores. Relationships between each station-specific average to overall OSCE average revealed a breadth of significance, from $r = .113$ (Station F) to $r(38) = .567$, $p = <.001$ (Station N).

Relationships between each category average to overall OSCE average scores also revealed a breadth of significance, from $r = .264$ (BASIC category) to $.776$, $p = <.001$ (EVAL category). Results of the Spearman correlation indicated positive associations between six of the seven category average scores and overall average scores; scores ranged from $.425$ to $.776$, $p = <.001$.

OSCE Evaluation

Of 40 participants, 32 completed an OSCE feedback survey (80%). In consideration of organization, the majority of students perceived OSCE to be fair (53%) and addressing a wide range of competencies (75%). A modest number of students considered the OSCE to be well administered (44%) and well structured (38%), while about half believed the experience to be neutral in terms of the chance of failure (56%).

The majority of students described OSCE to be a mix of good and bad stress (78%), and a mix of intimidating and approachable (84%). Students noted OSCEs to be less stressful than written or clinical exams (53% respectively). In relation to professional growth, most stated the experience helped to confirm their competence (72%) and helped them to identify areas for growth (81%).

Perception

Open-ended survey items included one question each regarding strengths, recommendations, and comments. Qualitative descriptive analysis revealed similar themes to emerge across questions. Time and stress were constant themes across each of the three questions. Many students reiterated the short time as eliminating the possibility of worrying about one's performance, while an equal number recommended slightly longer scenarios and transition to decrease the pressure to get to the next station. As with time, the theme of stress recurred as students recognized eustress and distress as influential on performance. Students described the short time frame and stress as challenging, useful to put an edge on their performance, and a sense that OSCEs were a safe place.

Common themes describing OSCE strengths included the variety of content and competencies enacted through interactive improvisation, and reflective of real-world concerns. The theme of organization and clear structure also emerged as a strength. Recommendations centered primarily around decreasing time and stress to perform quickly, as noted above. Themes from the thoughts and comments section expressed gratitude, positive experience, and learning a lot. A desire to complete more OSCE-type experiences in order to refine skills for Level II clinical placement was a recurrent theme. Authors also noted multiple outliers within a thematic category of insight. A handful of participants expressed surprise that OSCEs entailed reading, assimilating new information, limited background information or improvisation with mock clients.

DISCUSSION

Educational principles described by Khan et al. (2013) suggest the OSCE to be valid and reliable, as well as important for positive educational impact. Test content, handling of test items, learning impact, and stakeholder participation in development support

validity. The number of stations, standardized scoring criteria, and rater consistency for each station support reliability.

The first aim of the OSCE implementation was to provide an assessment of clinical competencies prior to students' departure for Level II fieldwork. At the close of the OSCEs, students received individualized spreadsheets with checklist ratings and global scores for each station. Students also received all rater comments regarding their performance. Spreadsheets supported summative assessment in which students identified FWPE categories and specific competencies in which they performed well, and formative assessment in which they identified categories and competencies in which they need practice prior to Level II fieldwork.

Students related understanding the structure of the OSCEs, however, they also expressed concern that they did not know what scenarios to expect and therefore could not prepare. The importance of adaptability through improvisation was indistinct for the students. The authors advocate emphasizing a goal of OSCEs is to develop flexibility in critical thinking as a precursor to practice. Authors also advocate additional individual follow up with students for summative assessment of clinical skills as well as formative assessment to focus on areas of improvement prior to fieldwork. As a group, students tended to find the experience valuable. Scaled items in the OSCE survey were congruent with student perception in open-ended items. Findings regarding student perceptions of time, stress, and positive learning were consistent with those noted by other authors (Al Nazzawi, 2018; Hemingway, Stephenson, Roberts, & McCann, 2014; Pierre, Wierenga, Barton, Branday, & Christie, 2004; Rasheel & Naeem, 2013).

The second aim of the OSCE was to provide information for program evaluation. The process prompted recurrent faculty discussion. Debriefing with practice stakeholders provided direction for minor curriculum modification. Faculty members are in the process of creating additional opportunities for small OSCE-like competencies across courses, learning domains, and complexity. Aggregate feedback could support larger program evaluation and curricular revision.

Limitations

A narrow set of stakeholders developed the OSCEs within a single university. There is currently no established set of OSCE stations from which to choose. Published work describing OT OSCEs is few and far between, limiting collegial brainstorming. Our development focused on the AOTA FWPE of clinical performance and Bloom's taxonomy of learning. There are undoubtedly other measures of clinical performance and other taxonomies of learning that could add different perspectives.

Future Research

OSCEs could serve as a useful assessment of practical skills, part of an array of assessments. Analysis to determine psychometric properties could inform the use of OSCEs in OT education. In their integrative review of OSCEs, Walsh, Bailey, and Koren (2009) suggested the construction of the OSCE can influence its reliability and validity. They further advocated that OSCEs be modified to reflect profession-specific needs.

Quantitative inquiry could examine validity and reliability, as well as longitudinal analysis for correlation of OSCEs with classroom performance, other didactic and lab course assessments, performance in clinical placement, and certification examination. Qualitative inquiry could examine stakeholder perceptions of OSCEs.

Implications for Occupational Therapy Education

The preparation, development, and implementation were manpower intensive and choreographically challenging; implementation involved a steep learning curve. There were no breaks during the two-hour rotation for raters/simulated patients. Raters/simulated patients had a one-hour break between the two groups of students. This rigorous schedule proved a challenge for rater fatigue. This was especially an issue for the rater whose role included drinking water. Authors provided a much-needed method for raters to ask for relief or support by text messaging or posting a sticky-note outside the station door. Some unattended stations were technology enhanced; however, instructional services loaner computers were less than robust. In addition, some areas of the building had inconsistent Internet access.

Stakeholders expect the intense process of choreography and planning to decrease with subsequent examinations. Each attended station would benefit from having both expert raters and simulated patients to relieve the time press for scoring when our raters took on simultaneous roles. A two-minute transition time would also relieve the time press for raters and students. For the next OSCE, technology-enhanced stations will be strategically placed in the building for improved Wi-Fi reception, as well as preloaded with necessary video files onto computers.

Inclement weather and illness caused precipitous absence of raters. The authors anticipated, recruited, and used backup raters to fill the gaps. Authors also substituted one technology-enhanced unattended station for a planned attended station. The authors were not assigned to stations, enabling them to troubleshoot.

Electronic data management would be helpful. All scoring for this OSCE was paper rather than digital, creating a monster of data management. Snodgrass, Ashby, and Rivett (2014) proposed electronic OSCEs (eOSCE) to improve efficiency and effectiveness. Authors described as advantageous digital marking, OSCE-specific software, data management, and distribution to students through a learning management system.

CONCLUSION

OSCEs are routinely used across health professions to demonstrate competence, prepare for clinical education, and conduct program evaluation, indicating compliance with educational standards. OSCEs appear advantageous to assess clinical competencies for a number of students within a short period of time. Walsh, Bailey, and Koren (2009) stated OSCEs are not intended to replace more protracted clinical assessment, but to assess clinical competence not currently addressed by other means.

The authors concur with Schaber's recommendation (2014) to investigate the experience of learning through doing. The authors continue to explore the utility of OSCE as a strategy to assess clinical competence in OT through analysis of outcome data. The OSCE designed for this project represent an isolated set of clinical competencies, related specifically to AOTA FWPE items. Stakeholders believed OSCEs could address universal rather than program specific clinical competencies. The authors recommend competencies of integration and critical thinking. The authors concur with Edwards and Martin (1989) in their recommendation to develop a bank of OT OSCE items, ideally with broad stakeholder input. We hope the application of OSCEs contributes to a larger discussion of assessment measures for competence in entry-level OT education.

References

- Al Nazzawi, A.A. (2017). Dental students' perception of the Objective Structured Clinical Examination (OSCE): The Taibah University experience, Almadinah Almunawwarah, KSA. *Journal of Taibah University Medical Sciences*, 13(1), 64-69. <https://doi.org/10.1016/j.jtumed.2017.09.002>
- American Occupational Therapy Association. (2002). *Fieldwork performance evaluation for the occupational therapy student*. Retrieved from http://cnhs.fiu.edu/ot/assets/documents/AOTA_FW_Perf_Eval_Student.pdf
- Awaisu, A., Abd Rahman, N., Nik Mohamed, M., Bux Rahman Bux, S., & Mohamed Nazar, N. (2010). Malaysian pharmacy students' assessment of an objective structured clinical examination (OSCE). *American Journal of Pharmaceutical Education*, 74(2), 34. <https://doi.org/10.5688/aj740234>
- Centre for Medical Education. Queen's University Belfast. (2012). OSCE examiner training and development. https://www.med.qub.ac.uk/osce/background_Scores.html
- Edwards, M., & Martin, A. (1989). Objective structured clinical examination as a method of occupational therapy student evaluation. *Canadian Journal of Occupational Therapy*, 6, (3), 128-131. <https://doi.org/10.1177/000841748905600306>
- Farahat, E., Javaherian-Dysinger, H., Rice, G., Schneider, L., Daher, N., & Heine, N. (2016). Exploring students' perceptions of the educational value of formative objective structured clinical examination (OSCE) in a nutrition program. *Journal of Allied Health*, 45(1), 20-6.
- Harden, R., & Gleeson, F. (1979). Assessment of clinical competence using an objective structured clinical examination (OSCE). *Medical Education*, 13(1), 39-54. <https://doi.org/10.1111/j.1365-2923.1979.tb00918.x>
- Harden, R., Stevenson, M., Downie, W., & Wilson, G. (1975). Assessment of clinical competence using objective structured examination. *British Medical Journal*, 1(5955), 447-451. <https://doi.org/10.1136/bmj.1.5955.447>
- Hemingway, S., Stephenson, J., Roberts, B., & McCann, T. (2014). Mental health and learning disability nursing students' perceptions of the usefulness of the objective structured clinical examination to assess their competence in medicine administration. *International Journal of Mental Health Nursing*, 23(4), 364-373. <https://doi.org/10.1111/inm.12051>

- Khan, K., Gaunt, K., Ramachandran, S., & Pushkar, P. (2013). The objective structured clinical examination (OSCE): AMEE Guide No. 81. Part II: Organisation & administration. *Medical Teacher*, 35(9), E1447-63.
<https://doi.org/10.3109/0142159X.2013.818635>
- Krusen, N. (2012). Improvisation as an adaptive strategy for leadership and practice. *Occupational Therapy in Health Care*, 26, 64-73.
<https://doi.org/10.3109/07380577.2011.637609>
- Lave, J., & Wenger, E. (1991). *Situated learning: Legitimate peripheral participation*. Cambridge, England: Cambridge University Press.
<https://doi.org/10.1017/CBO9780511815355>
- McWilliam, P., & Botwinski, C. (2010). Developing a successful nursing objective structured clinical examination. *Journal of Nursing Education*, 49(1), 36-41.
<https://doi.org/10.3928/01484834-20090915-01>
- Mezirow, J. (1981). A critical theory of adult learning and education. *Adult Education Quarterly*, 32, 3-24. <https://doi.org/10.1177/074171368103200101>
- Miller, G.E. (1990). The assessment of clinical skills/competence/performance. *Academic Medicine*, 65(9), 63-37.
<https://doi.org/10.1097/00001888-199009000-00045>
- Moliner, C. (2016, June). *Objective Structured Clinical Examination adapted to assess whole OT process and framework: Experiment it to understand*. Paper presented at First Joint Congress of the Council of Occupational Therapists in European Countries/European Network of Occupational Therapists in Higher Education.
- O'Brien, J., & McNeil, S. (2013). Teaching effectiveness: Preparing occupational therapy students for clinical practice. *Open Journal of Occupational Therapy*, 1(3), 2-11. <https://doi.org/10.15453/2168-6408.1045>
- Pierre, R., Wierenga, A., Barton, M., Branday, J., & Christie, C. (2004). Student evaluation of an OSCE in paediatrics at the University of the West Indies, Jamaica. *BMC Medical Education*, 4, 22-28.
<https://doi.org/10.1186/1472-6920-4-22>
- Raheel, H., & Naeem, N. (2013). Assessing the Objective Structured Clinical Examination: Saudi family medicine undergraduate medical students' perceptions of the tool. *Journal of the Pakistan Medical Association*, 63(10), 1281-1284.
- Rowe, P. (2015). A formulation and critical evaluation of an inter-personal communication skills objective structured clinical examination (OSCE) in pre-registration occupational therapy education. (Unpublished doctoral dissertation). University of Derby, England. Retrieved from
<https://core.ac.uk/download/pdf/130980071.pdf>
- Sakurai, H., Kanada, Y., Sugiura, Y., Motoya, I., Yamada, M., Tomita, M., . . . Okanisi, T. (2013a). Standardization of clinical competency evaluation in the education of physical therapists and occupational therapists - Establishment of an OSCE compliant education system. *Journal of Physical Therapy Science*, 25(1), 101-107. <https://doi.org/10.1589/jpts.25.101>

- Sakurai, H., Kanada, Y., Sugiura, Y., Motoya, I., Yamada, M., Tomita, M., . . . Okanishi, T. (2013b). Standardization of clinical skill evaluation in physical/occupational therapist education – Effects of introduction of an education system using OSCE. *Journal of Physical Therapy Science*, 25(9), 1071-1077. <https://doi.org/10.1589/jpts.25.1071>
- Sakurai, H., Kanada, Y., Sugiura, Y., Motoya, I., Wada, Y., Yamada, M., . . . Okanishi, T. (2014). Reliability of the OSCE for physical and occupational therapists. *Journal of Physical Therapy Science*, 26(8), 1147-1152. <https://doi.org/10.1589/jpts.26.1147>
- Schaber, P. (2014). Keynote address: Searching for and identifying signature pedagogies in occupational therapy education. *American Journal of Occupational Therapy*, 68(S2), S40-44. <https://doi.org/10.5014/ajot.2014.685S08>
- Snodgrass, S. J., Ashby, S. E., Rivett, D. A., & Russell, T. (2014). Implementation of an electronic objective structured clinical exam for assessing practical skills in pre-professional physiotherapy and occupational therapy programs: Examiner and course coordinator Perspectives. *Australasian Journal of Educational Technology*, 30(2), 152-166. <https://doi.org/10.14742/ajet.348>
- Townsend, E., & Polatajko, H. (2007). *Enabling occupation II: Advancing an occupational therapy vision for health, well-being & justice through occupation*. Ottawa, ON: CAOT Publications ACE.
- Walsh, M., Bailey, P., & Koren, I. (2009). Objective structured clinical evaluation of clinical competence: An integrative review. *Journal of Advanced Nursing*, 65(8), 1584-1595. <https://doi.org/10.1111/j.1365-2648.2009.05054.x>