



University of Kentucky
UKnowledge

KWRRRI Research Reports

Kentucky Water Resources Research Institute

10-1978

Development of a New Technique for the Analysis of Pesticides in Water

Digital Object Identifier: <https://doi.org/10.13023/kwrrri.rr.116>

Prasad K. Kadaba
University of Kentucky

Pramode K. Bhagat
University of Kentucky

Radko Osredkar
University of Kentucky

V. R. K. Murthy
University of Kentucky

Right click to open a feedback form in a new tab to let us know how this document benefits you.

Follow this and additional works at: https://uknowledge.uky.edu/kwrrri_reports

 Part of the [Water Resource Management Commons](#)

Repository Citation

Kadaba, Prasad K.; Bhagat, Pramode K.; Osredkar, Radko; and Murthy, V. R. K., "Development of a New Technique for the Analysis of Pesticides in Water" (1978). *KWRRRI Research Reports*. 86.
https://uknowledge.uky.edu/kwrrri_reports/86

This Report is brought to you for free and open access by the Kentucky Water Resources Research Institute at UKnowledge. It has been accepted for inclusion in KWRRRI Research Reports by an authorized administrator of UKnowledge. For more information, please contact UKnowledge@lsv.uky.edu.

DEVELOPMENT OF A NEW TECHNIQUE FOR THE
ANALYSIS OF PESTICIDES IN WATER

By

Prasad K. Kadaba
Principal Investigator

Pramode K. Bhagat
Faculty Associate

Radko Osredkar
V. R. K. Murthy
Research Associates

Project Number: A-065-KY (Completion Report)

Agreement Numbers: 14-34-0001-6018 (FY 1976)
14-34-0001-7037 (FY 1976T)
14-34-0001-7038 (FY 1977)

Period of Project: April 1, 1976 - September 30, 1978

University of Kentucky
Water Resources Research Institute
Lexington, Kentucky

The work on which this report is based was supported in part by funds provided by the Office of Water Research and Technology, United States Department of the Interior, as authorized under the Water Resources Research Act of 1964.

October 1978

ABSTRACT

A Nuclear Double Resonance Spectrograph has been designed and constructed with emphasis on quadrupolar nuclei of half-integral spins. The use of a data acquisition and processing system featuring the A/D converter, signal averager with built in fast Fourier transformation hardware greatly improves the S/N ratio. The spectrograph has been used to detect certain organochlorine, carbamate and symmetrical triazine pesticides. Concentration levels that can be detected range from 15 to 100 micrograms per liter. Since the measurements are done below ice temperatures, heat-labile compounds can be detected without conversion to more suitable derivatives as in gas chromatography. Fats and oils in sample extracts do not interfere with the measurements. Further improvement in sensitivity is possible by using liquid nitrogen-cooled, ferrite-cored electromagnet, by increasing the polarizing field and by reducing receiver recovery time.

In addition to analysis of pesticides, the Nuclear Double Resonance technique can be used to study the electronic structure of molecules.

Descriptors: Spectroscopy*, Spectrometers*, Trace Elements*,
Pesticides, Organic Compounds, Carbamate Pesticides

Identifiers: Nuclear Double Resonance Spectrograph

ACKNOWLEDGMENTS

The Principal Investigator acknowledges the continued encouragement and support of Dr. Robert B. Grieves, Director, and Dr. Ralph Huffsey, Associate Director, Kentucky Water Resources Research Institute. Also acknowledged is the support for equipment to the extent of \$10,000 for this project from Dr. Wimberly Royster, Dean of the Graduate School, and from the Major Equipment Committee of the University of Kentucky.

The Principal Investigator expresses his thanks to Professor J. W. Doane, Professor of Physics at Kent State University, Kent, Ohio, for the use of the Fourier Transform Pulsed Spectrometer to obtain preliminary data on some of the pesticides. He also expresses his thanks to the Morgantown Energy Research Center, Morgantown, West Virginia, for the use of the Bruker Pulsed Spectrometer in this investigation, while the Principal Investigator was a Visiting Scientist on an Oak Ridge Associated Universities fellowship in the summer of 1976.

Postdoctoral fellows who were funded by the KWRRI grant included Dr. Radko Osredkar from the Institut Jozef Stefan, Ljubljana, Yugoslavia, and Dr. V. R. K. Murthy from the Indian Institute of Technology, Madras, India. Others contributing to the research project were James E. Harvey, doctoral candidate, Mike Montgomery and George Broomell. The excellent typing provided by Ms. Gail McAlister is gratefully acknowledged.

TABLE OF CONTENTS

	<u>Page</u>
ABSTRACT	i
ACKNOWLEDGMENTS.	ii
TABLE OF CONTENTS.	iii
LIST OF TABLES	iv
LIST OF FIGURES.	v
CHAPTER I: INTRODUCTION	1
CHAPTER II: RESEARCH PROCEDURES AND DETAILS OF EQUIPMENT DESIGN.	3
i. Physical Principle of the Method	3
ii. Detection Sensitivity Considerations	5
iii. Details of the Design.	8
iv. Electronic Circuit Details of the Modules that were Designed and Constructed	13
v. Experimental Methodology	13
vi. Sample Preparation, Extraction and Concentration.	24
CHAPTER III: DATA AND RESULTS	25
CHAPTER IV: CONCLUSIONS.	37
REFERENCES AND BIBLIOGRAPHY.	38

LIST OF TABLES

<u>Table</u>		<u>Page</u>
I	QUADRUPOLE RESONANCE FREQUENCIES, ν_Q , AND THE VARIOUS RELAXATION TIMES OF CARBANOLATE	27
II	MINIMUM DETECTABLE CONCENTRATIONS OF THE PESTICIDES TESTED.	35

LIST OF FIGURES

<u>Figure</u>		<u>Page</u>
1	TIME SEQUENCE FOR DETECTING LOW CONCENTRATION B-SPIN ZERO FIELD QUADRUPOLE RESONANCE.	4
2	BLOCK DIAGRAM OF PULSED SPECTROMETER (A-SIDE).	9
3	BLOCK DIAGRAM OF DOUBLE RESONANCE PULSE PROGRAM AND B SATURATION	10
4	DEWAR DIMENSIONS INCLUDING LOCATION OF THE A AND B COILS.	11
5	DETAILS OF PNEUMATIC CONTROL	12
6	TIME DIAGRAM FOR DOUBLE RESONANCE PULSE PROGRAM.	14
7	SCHEMATIC OF PRE-AMPLIFIER	15
8	INTERFACE UNIT CONNECTING THE RF PULSE TRANSMITTER TO A-COIL.	16
9	SCHEMATIC OF SOLENOID VALVE DRIVER	17
10	SCHEMATIC OF π -PHASE SHIFT MODULATOR	18
11	SCHEMATIC OF 12 AND 5 VOLT POWER SUPPLIES.	19
12	SCHEMATIC OF RF AMPLIFIER AND DETECTOR	20
13	BASIC SCHEMATIC OF THE SUPERREGENERATIVE SPECTROMETER.	23
14	NQR SPECTRUM OF ³⁵ Cl IN PURE CARBANOLATE	26
15	PROTON FID SIGNAL OF CARBANOLATE AT ROOM TEMPERATURE AND AT A FREQUENCY OF 61 MHz	28
16	FOURIER TRANSFORM REPRESENTATION OF CARBANOLATE PROTON FID SIGNAL.	29
17	DOUBLE RESONANCE EFFECT OF CHLORINE IN CARBANOLATE AT A CONCENTRATION OF 100 ppm. THE EFFECT IS THE DIFFERENCE IN HEIGHTS OF THE TWO FID SIGNALS SHOWN.	31
18	FOURIER TRANSFORM REPRESENTATION OF THE CHLORINE SIGNAL OF CARBANOLATE AFTER SIGNAL AVERAGING (CONCENTRATION 1 ppm).	32

<u>Figure</u>		<u>Page</u>
19	FOURIER TRANSFORM REPRESENTATION OF THE CHLORINE SIGNAL OF CARBANOLATE AFTER SIGNAL AVERAGING (CONCENTRATION 100 ppb)	33
20	FOURIER TRANSFORM REPRESENTATION OF THE CHLORINE SIGNAL OF CARBANOLATE AFTER SIGNAL AVERAGING (CONCENTRATION 20 ppb)	34

CHAPTER I
INTRODUCTION

The objective of the project was the development of a new technique for the detection of certain pesticides in water at low concentrations. The new technique envisaged in this investigation is the Nuclear Double Resonance technique which has been successfully used for detecting pure nuclear quadrupole interactions of rare isotopes such as D, O¹⁷, S³³, Ca⁴³, etc. in certain solids which can provide a strong resonance from an abundant nuclear species such as protons. A cursory theoretical analysis of the detection-sensitivity considerations has been undertaken. The technique has been applied for the detection of certain organochlorine, carbamate, and symmetrical triazine pesticides. Detection at low concentrations was made possible by suitable signal averaging techniques and using the extraction and concentration procedures that are available in the literature.¹ Since the physical principle of the method involves measurements below ice temperatures, there was no problem about detecting heat-labile compounds such as carbamate pesticides. Electron capture gas chromatography, although more sensitive, cannot be used to analyze directly most carbamate pesticides because they are thermally unstable. Further improvement in the sensitivity of the technique developed in the project is possible by choosing a higher proton-resonance frequency since the receiver recovery time, which is an important factor affecting sensitivity, is inversely proportional to the proton resonance frequency. It is desirable to have the receiver recovery time as short as possible. The proton resonance frequency used in the study was close to 40 MHz, limited by the 10 Kgauss magnetic field available. Higher proton resonance frequency would entail a higher magnetic field.

A major portion of the effort was the design and construction of this rather sophisticated and sensitive spectrometer. This involved the design and construction of certain electronic modules which were neither commercially available nor suitable for the specific requirements of the project. Units such as the rf linear power amplifiers

that are available commercially have a large band width and cost several thousand dollars. Since the band width requirements in the present design were rather narrow (couple of MHz), these units were constructed in the laboratory. Details are given in Chapter II.

CHAPTER II
RESEARCH PROCEDURES AND DETAILS OF EQUIPMENT DESIGN

Since the major objective of this project was the design and construction of a rather sophisticated and sensitive instrument, the various aspects of the design are outlined below in sufficient detail.

i) Physical Principle of the Method

The method involves the measurement of the pure nuclear quadrupole resonance of a very low-abundance spin species (B) in terms of a decrease in the magnetic order of abundant nuclei (A) which are dipolar-coupled to the low-abundance nuclear species.

Nuclear Double Resonance was first conceived by Hartmann and Hahn² and later on developed as an ultrasensitive method by Slusher and Hahn³ for detecting pure nuclear quadrupole interactions of rare isotopes such as D, O¹⁷, S³³, Ca⁴³, etc., in suitable crystals which can provide a strong resonance from an abundant nuclear species. The method is also suitable for amorphous solids and crystalline powders in zero magnetic field, because the nuclear quadrupole resonance transition is uniquely determined by internal electric fields. Figure 1 shows the time sequence for detecting the low concentration B-spin zero field quadrupole resonance. First the A nuclei are polarized in a d.c. magnetic field. This places the A spins in an ordered metastable magnetic state. The entire spin ensemble is characterized as metastable because it is no longer in thermal equilibrium with the lattice. The B resonance is then excited by applying a radio-frequency field after the sample is removed from the magnet to a region of zero external field for a time period $t \approx \tau_0$. In general, the sample demagnetization is performed adiabatically in a time short compared to the spin-lattice relaxation time [(a) to (b) in Fig. 1]. In the demagnetized state the entropy of the A system is formally preserved. However, the order it represents in terms of alignment of nuclei along local dipole fields will decay in a modified spin-lattice time constant T_{1d} , which is generally shorter than the high field spin-lattice relaxation time T_1 .

Figure 1

Time sequence for detecting low concentration B-spin
zero field quadrupole resonance.

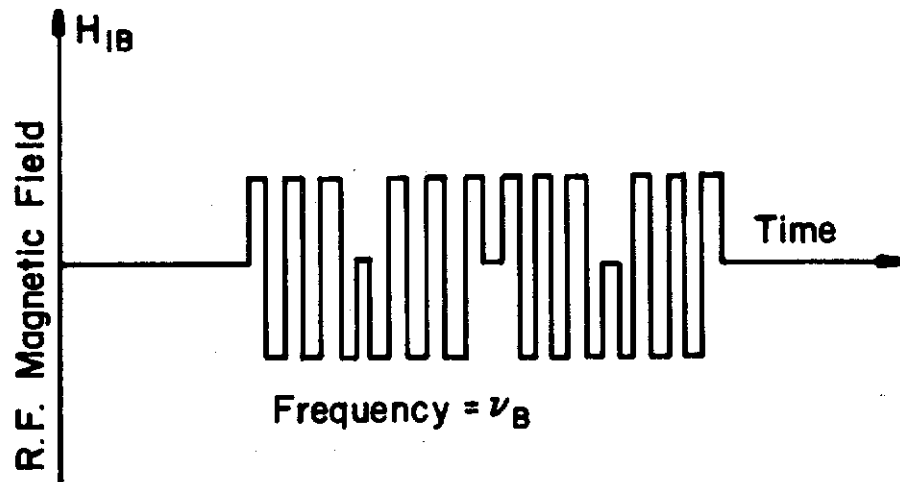
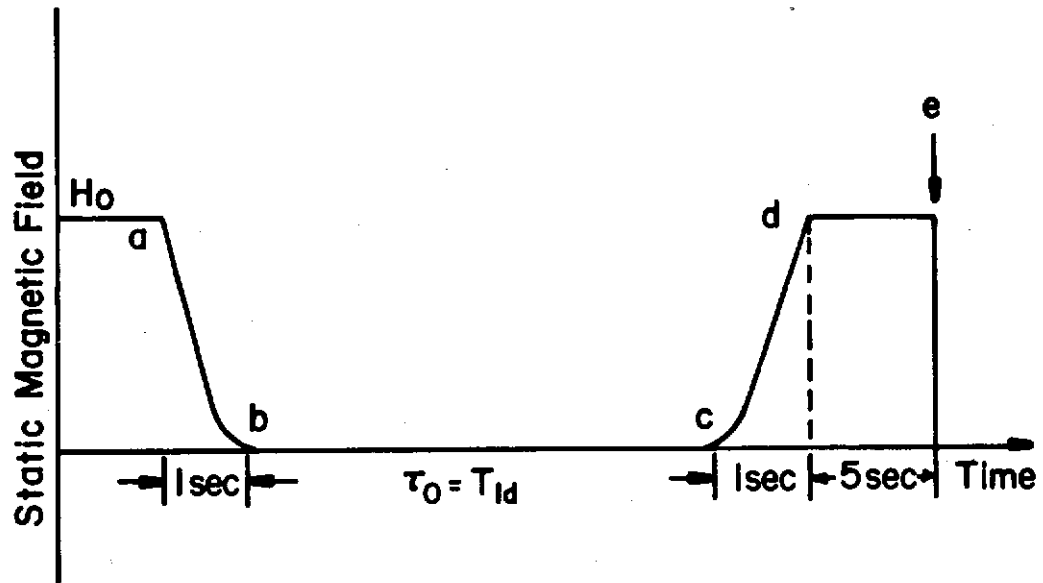

The B nuclei are irradiated with an rf field intensity H_{1B} at the time points (b) to (c), lasting for a time τ_0 of the order of T_{1d} , indicated in Fig. 1. The double resonance cross-relaxation rate R_{AB} which is a measure of the transfer rate of spin ordering from the A to the B system is greatest when

$$\nu_B H_{1B} \approx \gamma_A h_L \text{ and } \nu_B = \nu_Q$$

where h_L is the mean local dipole field at the sites of A nuclei, γ is the gyromagnetic ratio, and ν_Q is the quadrupole resonance frequency of the B nuclei. At point (c) the sample is adiabatically remagnetized by the former polarizing field. Any remaining order of the A nuclei is measured by applying a 90° pulse at time point (e), and the intensity of the free nuclear induction decay is recorded.

In order to achieve high sensitivity, the spin order, which is transferred from the A system to the B system, must be continually destroyed by saturation of the magnetization which builds up along the effective field applied to the B spins. A scheme for achieving this saturation is by frequency modulating the main rf excitation which is at resonance with the B spins transition. Alternatively, π -phase shift modulation of the rf excitation can be used. Both these techniques were used in this investigation.

ii) Detection Sensitivity Considerations

In the experiment, the abundant A nuclei (protons) are polarized in the high field and then moved to zero field by the pneumatic drive mechanism. The A-nuclei are now in a magnetically ordered state after adiabatic demagnetization to zero field. They are at equilibrium with a low uniform spin temperature, $T_A(0)$. Next the rf field H_{1B} at the quadrupole resonance frequency of the B nucleus is turned on. If H_{1B} is applied suddenly in the quantum mechanical sense,⁴ the energy levels of the B rf Hamiltonian in the interaction representation, H_{rFB}^* , may be assumed to be equally populated. This initial state of the B nuclei is described by an infinite spin temperature,

$$\frac{1}{T_B^*(0)} = 0$$

The magnetically ordered A nuclei will gradually order the B nuclei. In the language of thermodynamics, the A and B energy reservoirs will come to a common equilibrium spin temperature,

$$T_B^*(\tau_e) = T_A(\tau_e)$$

after a time, τ_e , which is determined by \mathcal{H}_{AB}^* (the coupling interaction between the energy reservoirs established by interactions A and B) and the spin diffusion in the A system.

It can be shown that

$$\frac{T_A(\tau_e)}{T_A(0)} = 1 + 2\varepsilon$$

where

$$\varepsilon = \frac{N_B \omega_{1B}^2}{4\pi^2 \sum_{j \neq k}^A \gamma_{Aj}^2 \gamma_{Ak}^2 r_{jk}^{-6} I_j(I_j + 1) I_k(I_k + 1)}$$

Here,

N_B = number of B nuclei per unit volume

γ_A = gyromagnetic ratio of A nuclear spin

I = nuclear spin

$\omega_{1B} = \gamma_B H_{1B}$ where γ_B is the gyromagnetic ratio of B nuclear spin.

In simple terms, ε is the ratio of the heat capacities of the B and A spin systems. In the experiment, the B nuclei need to be continuously disordered. This is accomplished, for example, by sudden 180° phase shifts of H_{1B} . The rate at which the phase of H_{1B} is shifted is of the order of $\frac{1}{T_{AB}^*}$

where T'_{AB} is the time required for a B nucleus to achieve mutual spin flips with neighboring A nuclei. After n -phase shifts at intervals of τ_e ,

$$T_A(n\tau_e) = T_A(0) \left[1 + 2n\epsilon + \frac{n(n-1)4\epsilon}{2!} + \frac{n(n-1)(n-2)9\epsilon^3}{3!} + \dots \right]$$

which for large n becomes

$$T_A(n\tau_e) \approx T_A(0)e^{-2n\epsilon}$$

The sample is remagnetized after τ_0 seconds involving n phase shifts of H_{1B} in zero static field. The nuclear dipole order is reformed as a magnetization which is inversely proportional to $T_A(n\tau_e)$; this yields for the total magnetization of the spin system after τ_0

$$M_z(\tau_0) = M_z(0)e^{-2n\epsilon} = M_z(0)e^{-\frac{\tau_0}{T_{AB}}}$$

where

$$n = \frac{\tau_0}{\tau_e} \text{ and } \tau_{AB} = \frac{\tau_e}{2\epsilon}$$

In this analysis the spin-lattice interactions are neglected. A practical limit on τ_0 is the dipolar spin-lattice relaxation time, T_{1d} . If the signal-to-noise ratio of the A nuclei is good enough to see a one percent change in the effective relaxation time, the minimum detectable concentration of B nuclei is

$$\frac{N_B}{N_A} \Big|_{\min} \approx \frac{T'_{AB}}{100T_{1d}}$$

Typical values are in the range:

$$T'_{AB} \approx 50 \text{ to } 500 \text{ } \mu\text{secs. and } T_{1d} \approx 10 \text{ to } 100 \text{ secs.}$$

so that

$$\left. \frac{N_B}{N_A} \right|_{\min} \approx 5 \times 10^{-9} - 5 \times 10^{-7}$$

At the higher sensitivity in a sample of pesticide dissolved in a compatible solvent such as acetone or bromoform, this leads to about 500 ng of a typical pesticide, say, carbanolate, as the theoretical limit of amount necessary for detection. This is a theoretical upper limit of sensitivity of 0.5 ppb. So under optimum conditions with good signal averaging techniques, it should be possible to detect about 2 ppb of a typical compound.

iii) Details of the Design

Figure 2 shows the block diagram of the Pulsed Spectrometer (A-side). Figure 3 shows the block diagram of the Double Resonance part of the spectrometer including the B-saturation modules. Figure 4 shows the dimensions of the Dewar capable of operation down to liquid nitrogen temperature. The positions and dimensions of the A and B coils are also shown. Figure 5 shows the details of the pneumatic control which is used to move the sample adiabatically from the A-position in high field to the zero field B-position and then back to the A-position after the completion of the Double Resonance cycle. The pneumatic drive is activated by an air compressor. The units shown in the block diagrams of Figures 2 and 3 are described below:

FG 501: Tektronix function generator

RG 501: Tektronix ramp generator

PG 505: Tektronix pulse generator (Schmitt trigger)

IEC F34: Function generator capable of variable frequency square wave output of 20 volts or higher

ADC Biomation: Model 8100 Analog Waveform Recorder, Biomation Co., California

Figure 2

Block diagram of Pulsed Spectrometer (A-side).

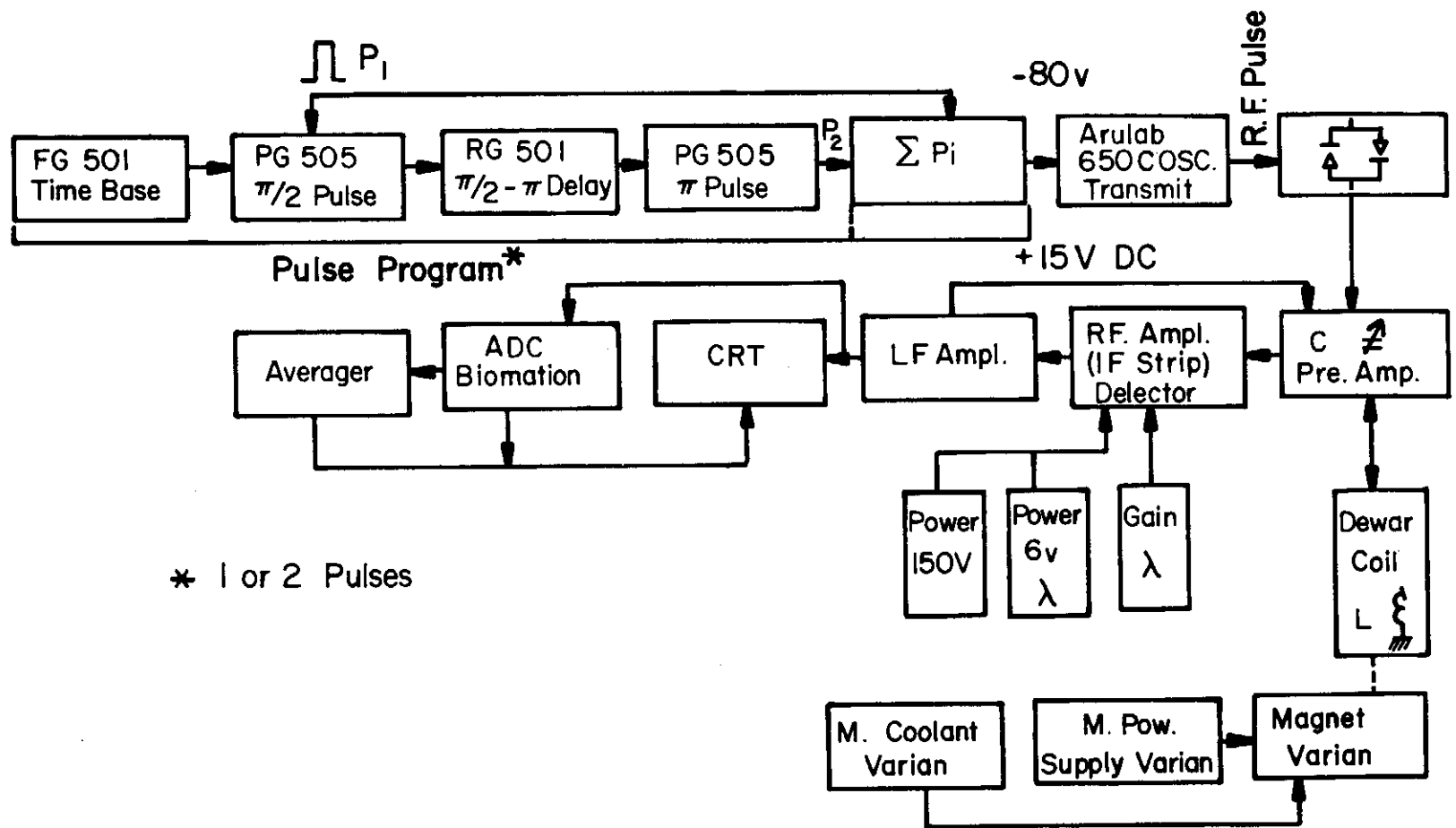

Figure 3

Block diagram of Double Resonance pulse program and B saturation.

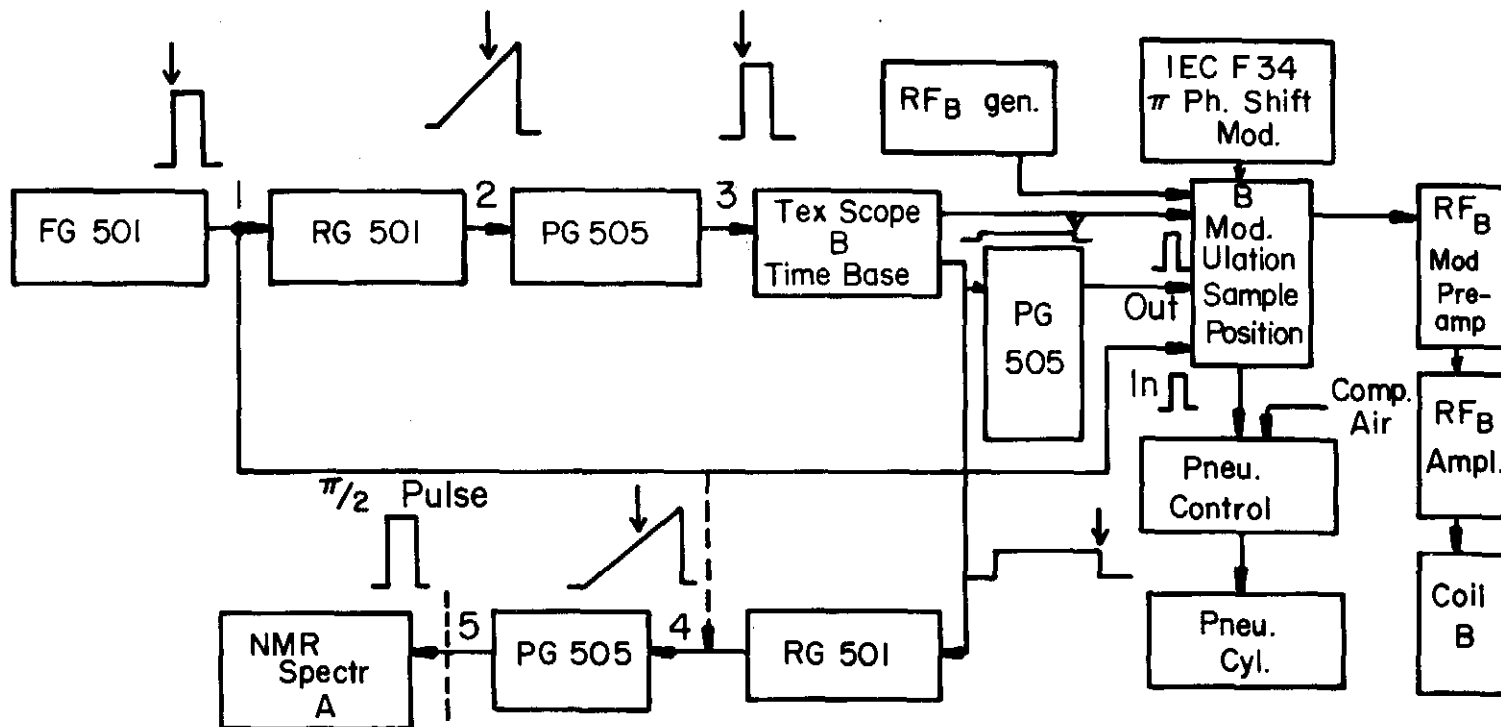

Figure 4

Dewar dimensions including location of the A and B coils.

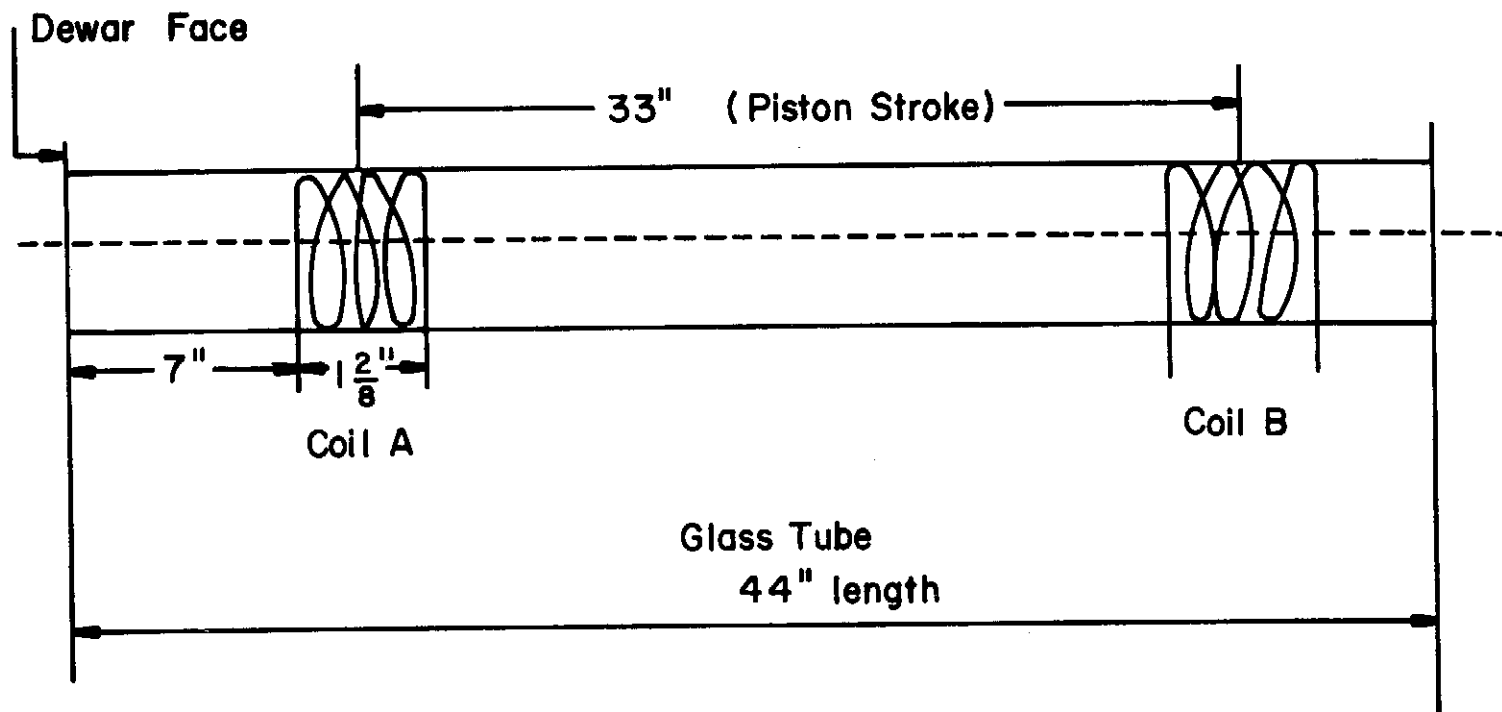
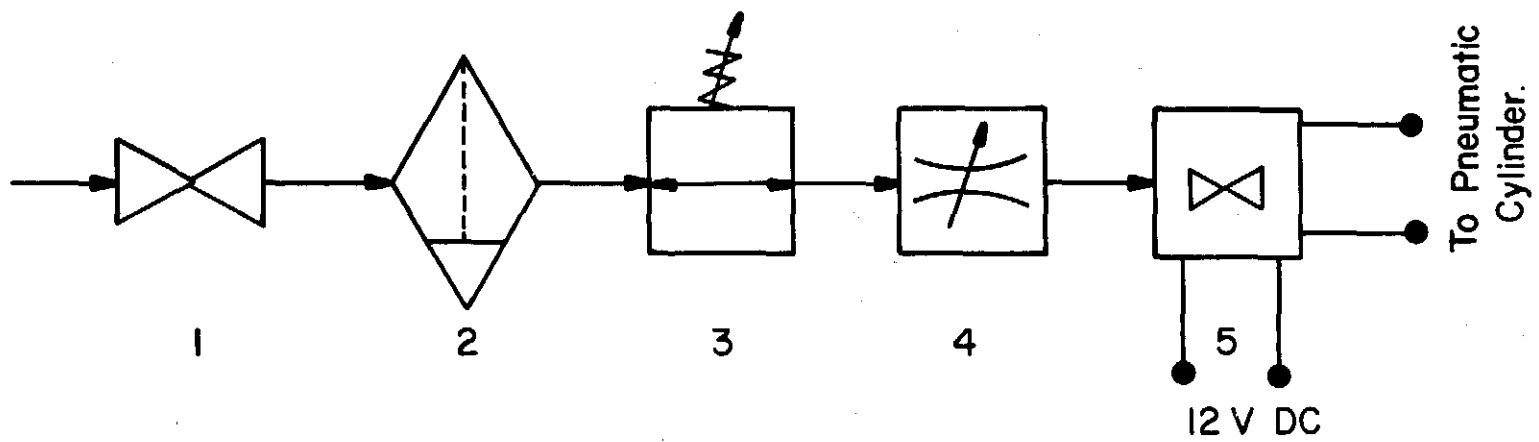

Figure 5
Details of pneumatic control.



- 1 Valve
- 2 Filter Clippard R-80I
- 3 Pressure Regulator Clippard R70I

- 4 Flow Control Valve Clippard R-50I
- 5 Electronic Valve Clippard R48I-12.

Figure 6 shows the time diagram for the Double Resonance pulse program.

iv) Electronic Circuit Details of the Modules that Were Designed and Constructed

These schematics are shown in Figures 7 through 12. Figures 7 and 8 are, respectively, the schematic of the pre-amplifier and the interface unit connecting the rf pulse transmitter to the A-coil. Figure 9 is the schematic of the solenoid valve driver. Figure 10 is the schematic of the π -phase shift modulator. Figure 11 is the schematic of the 12 and 5 volt power supplies. Figure 12 is the schematic of the rf amplifier and detector which was a radar I.F. strip modified to suit our requirements.

The CW rf power amplifier capable of 500 watts output power was a Heath SB 220 linear amplifier modified to operate in the frequency region 34 to 37 MHz. This covers all the chlorine quadrupole resonance frequencies of interest. The band width of this amplifier was also modified to accept narrow band FM signals. The input to the SB 220 was a class AB power amplifier capable of up to 50 watts output when supplied by a 20 volt input from a Boonton voltage amplifier. The input to the Boonton voltage amplifier was supplied from the General Radio Type 1025-A signal generator amplified by a solid-state voltage amplifier. The General Radio signal generator can be replaced by a frequency synthesizer ($5 \frac{1}{2}$ digit), Pacific Measurement Co., and, if available, is more convenient to use.

v) Experimental Methodology

The experiment was performed in a stainless-steel dewar manufactured by the Andonian Co., Cambridge, Mass. The dewar was mounted horizontally in a 12" Varian electromagnet which was modified by grinding and annealing the pole pieces so that about $2 \frac{1}{2}$ " pole gap obtains to accommodate the dewar assembly. The supply for the magnet is regulated to 1 part in 10^5 providing the stability necessary for the Double Resonance experiment. Timing of the entire Double Resonance cycle is automatically controlled by a series of Tektronix 500-series wave form generators. The sample is contained in a teflon

Figure 6

Time diagram for Double Resonance pulse program.

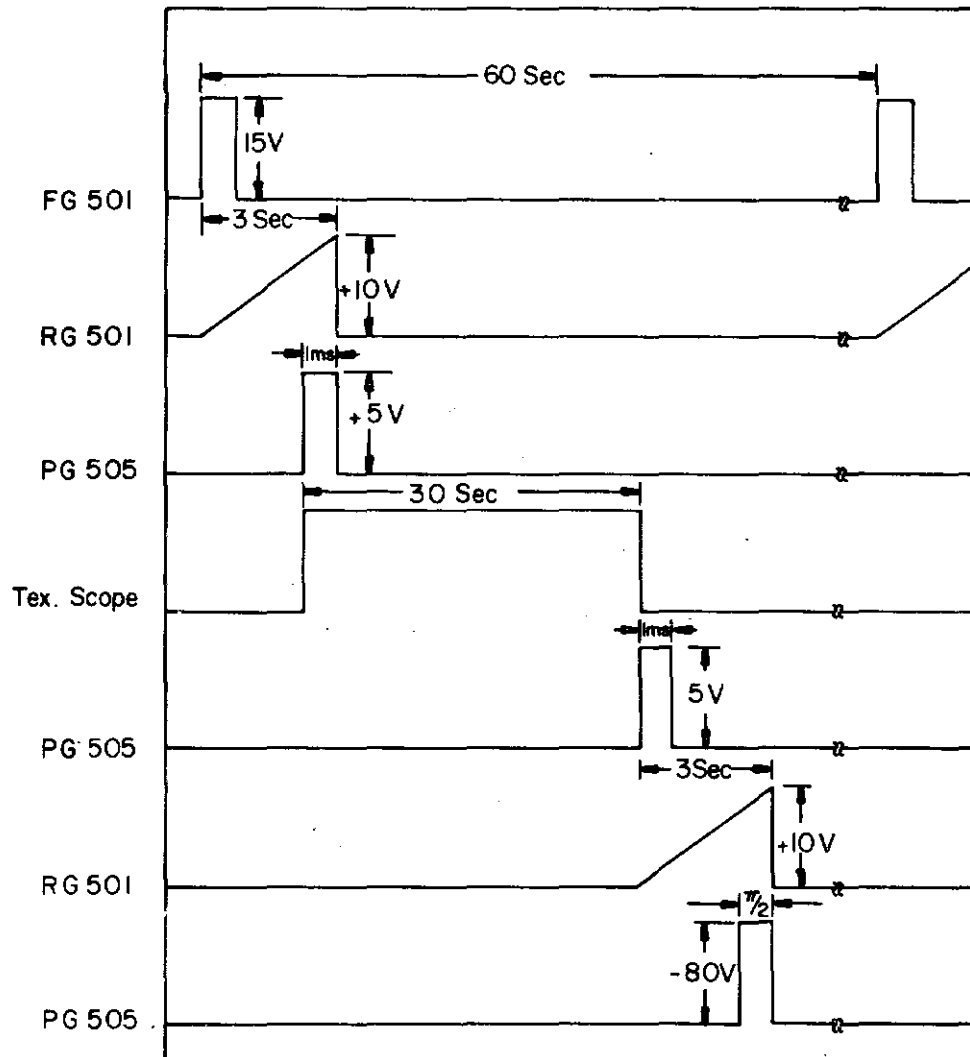
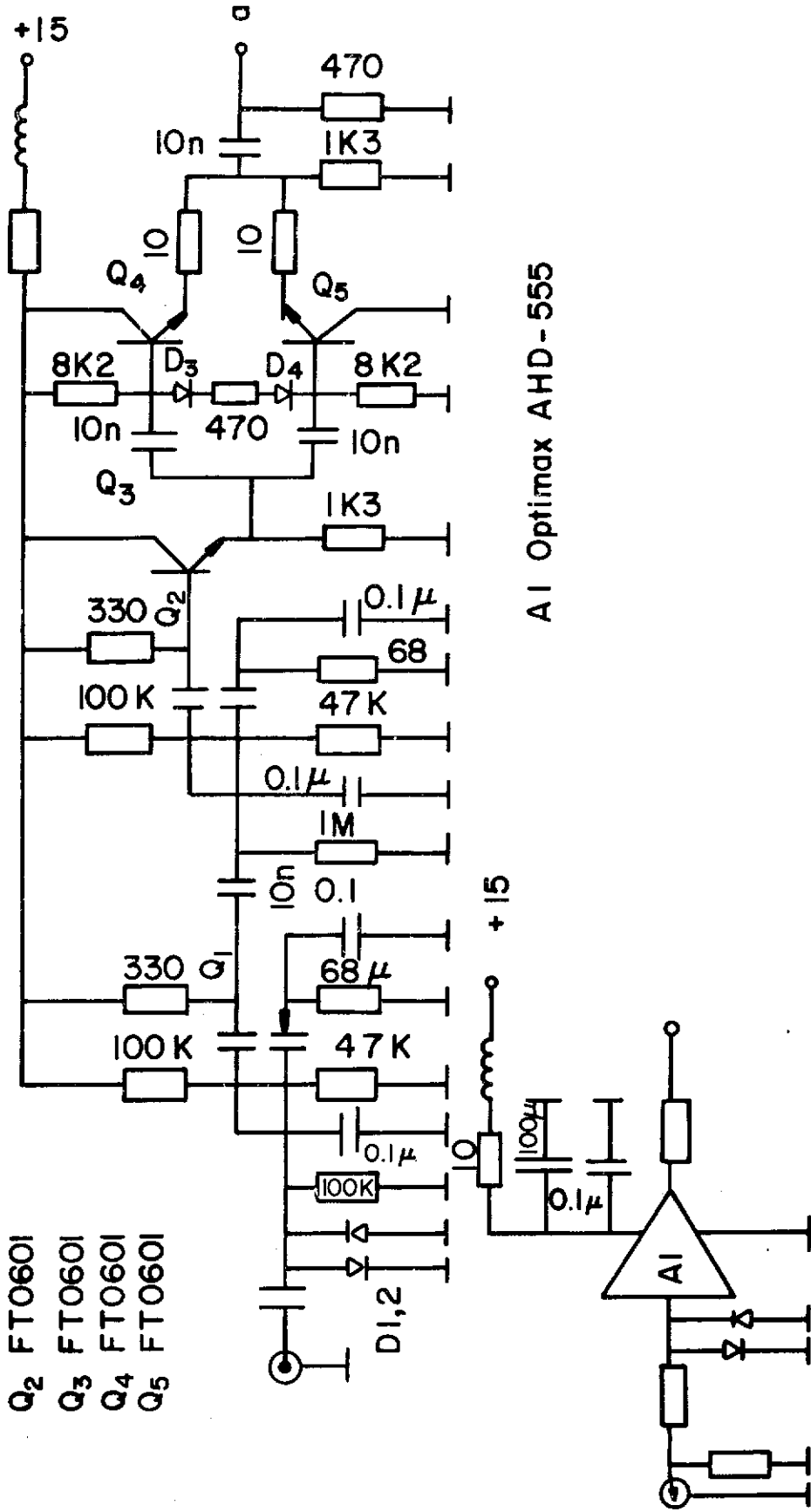

Figure 7

Schematic of pre-amplifier.

Pre Amplifier

- Q1 FT0601
- Q2 FT0601
- Q3 FT0601
- Q4 FT0601
- Q5 FT0601



AI Optimax AHD-555

Figure 8

Interface unit connecting the rf pulse transmitter to A-coil.

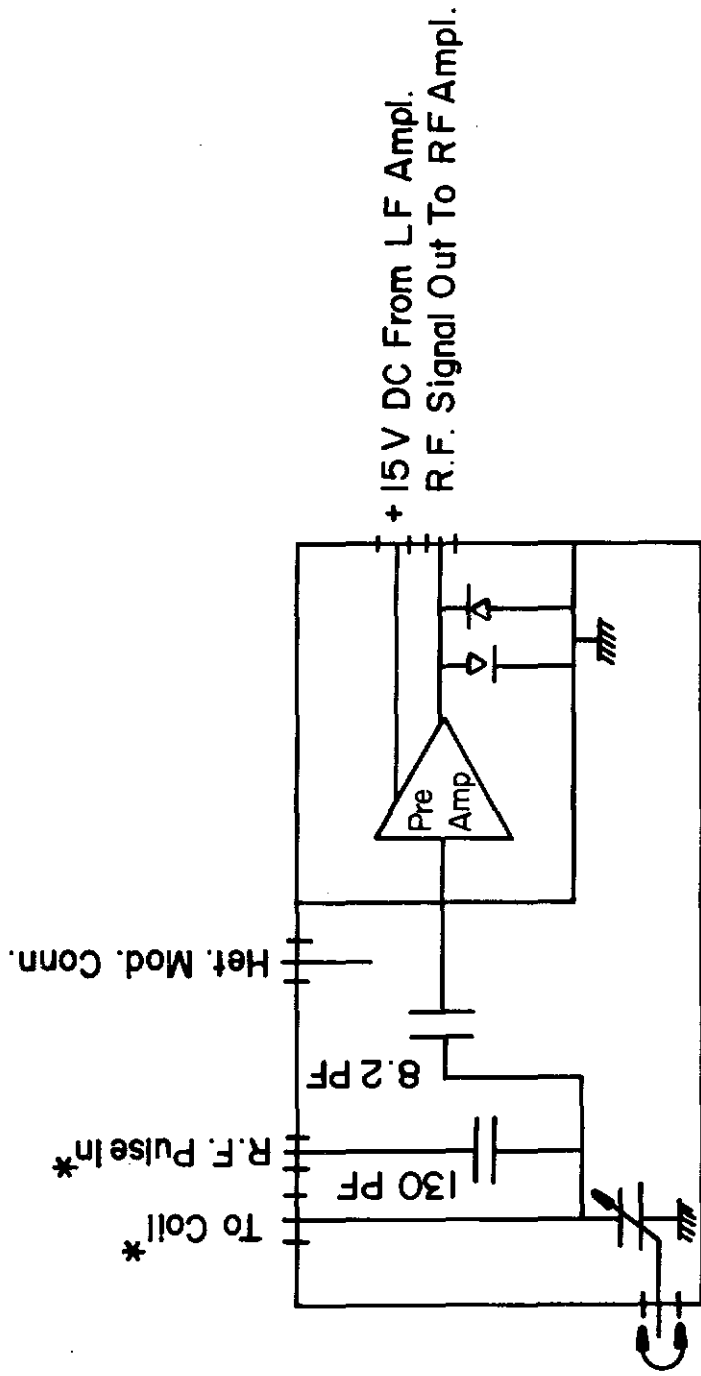

* Cables Of Predetermined Length And Impedence.

Figure 9

Schematic of solenoid valve driver.

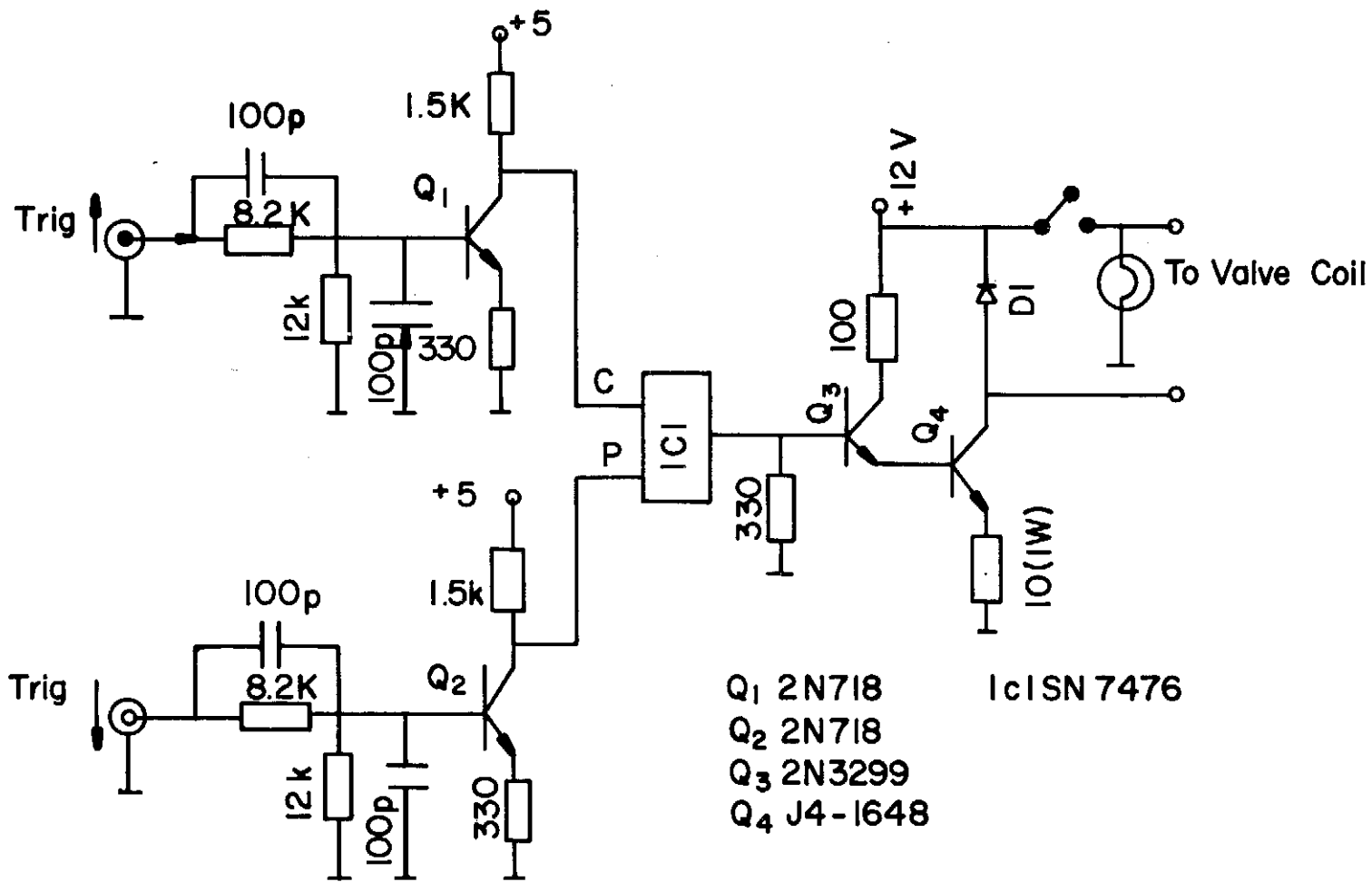

- Q₁ 2N718
- Q₂ 2N718
- Q₃ 2N3299
- Q₄ J4-1648

Figure 10

Schematic of π -phase shift modulator.

Figure 11

Schematic of 12 and 5 volt power supplies.

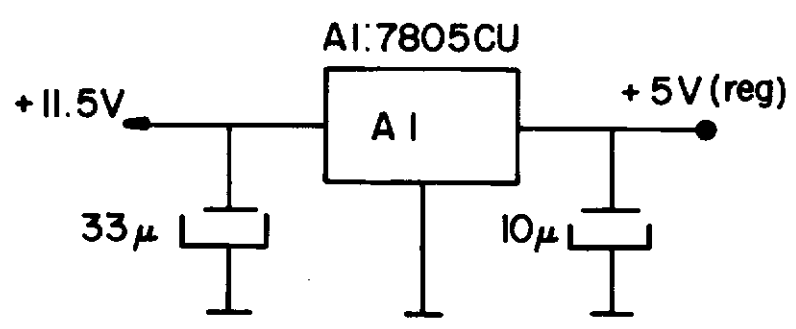
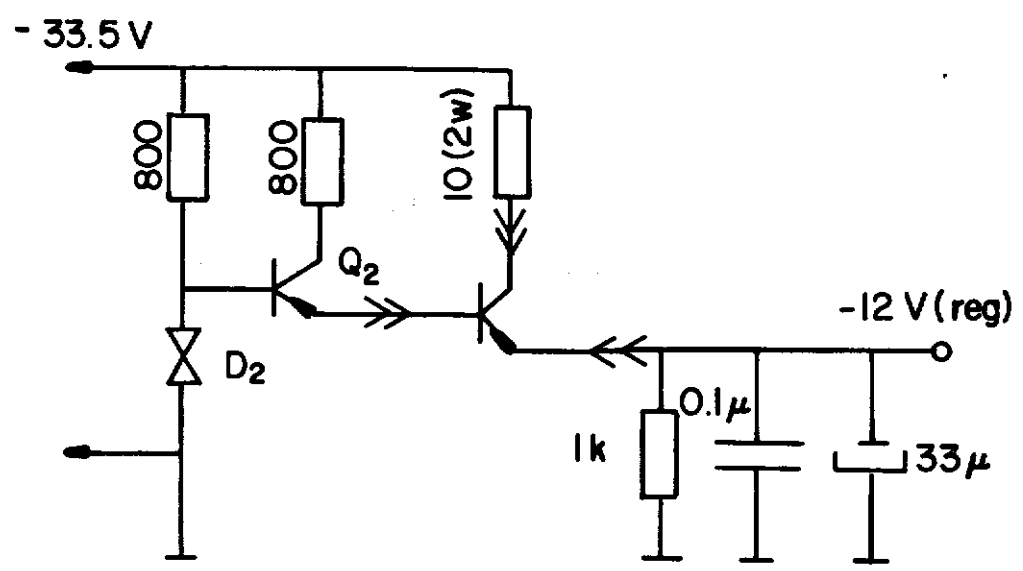
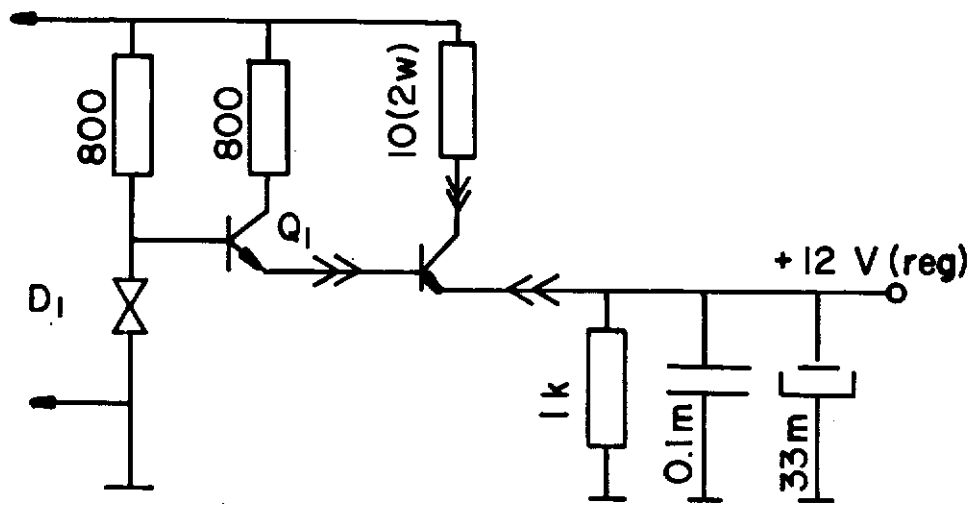
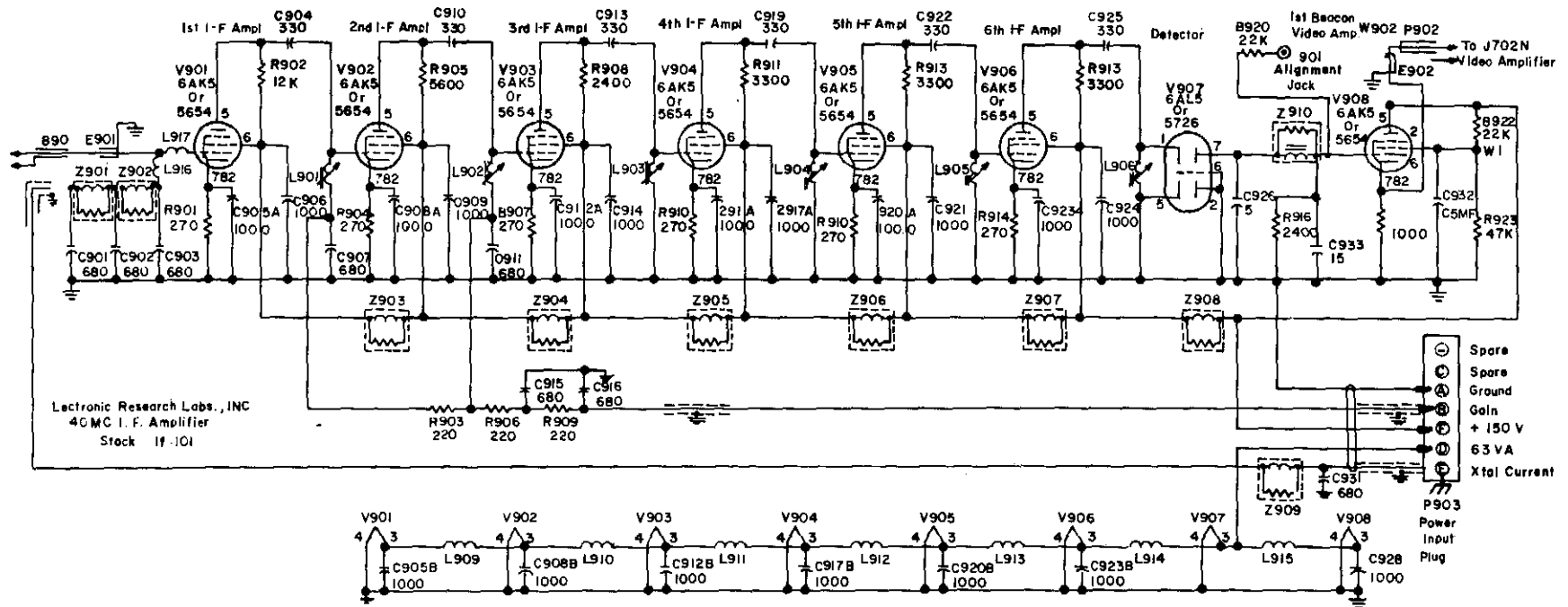

Figure 12

Schematic of rf amplifier and detector.



tube, $\frac{3}{4}$ " diameter and $1\frac{1}{4}$ " long, and is first positioned in the A-position at the center of the electromagnet. In order to reduce the recovery time of the receiver, the Arenberg 650 C pulsed transmitter which provides the $\frac{\pi}{2}$ pulses was tuned to 38.3 MHz and the receiver was tuned to 40 MHz. This reduces the recovery time to less than ten microseconds or so, so that a good free induction decay signal (FID) is obtainable in the solid phase. Free induction decay for protons in solids usually range from 5 to 50 μ seconds. The transmitter pulse was of the order of 400 volts.

The A-side of the spectrometer was first tuned with a water sample containing a small amount of a paramagnetic salt such as Fe_2Cl_3 . This is the best way to tune the magnetic field to the proton Larmor frequency of 38.3 MHz used in the experiment. If the tuning is right, one should see a very good FID signal with a S/N ratio of 100 : 1 or better. The pesticide sample dissolved in a suitable solvent such as bromoform is now substituted for the above water sample and cold nitrogen vapor from a nitrogen dewar is passed through the tubular Andonian dewar assembly. The sample is cooled to less than -20°C for most of the measurements. The temperature of the sample was held to $\pm 0.5^\circ\text{C}$. The sample is now polarized in the high static field of the electromagnet. This requires a time of the order of the spin-lattice relaxation time T_1 . After polarization, the sample is moved adiabatically to the zero field B-position. Thus the protons in the sample (A-nuclei) are adiabatically demagnetized to a field of the order of the local dipolar fields. The sample, in the zero field region, is in the center of the B-solenoid that generates the rf magnetic field, H_{1B} . This solenoid is part of the tuned output circuit of the linear B rf amplifier. The phase-shift or frequency modulation of H_{1B} is determined at the input to this amplifier by the RF_B π -phase shift modulator or the Marconi FM signal generator. The magnetic order of the A nuclei decreases during the time in the zero field region because of spin-lattice relaxation and cross relaxation with the irradiated B nuclei. The modulation frequency

$$f_m = \frac{1}{\tau_\pi}$$

for the π -phase shift should be at least equal to or larger than $\frac{1}{\tau_{AB}}$ where τ_{AB} is the cross relaxation time.

$$\tau_{AB} \approx \frac{1}{\sqrt{M_{AB}^{(2)}}}$$

where $M_{AB}^{(2)}$ is the second moment of the interaction between the A and B nuclei. If f_m is smaller, the Double Resonance effect is reduced because not all disorder in the B system can be transferred from the B system to the A system. However, once f_m is high enough to achieve full Double Resonance effect, increasing it further does not help any and, if one goes to even higher frequencies, the band width of the irradiation frequency might become intolerably high.

The time τ_0 in the zero field region should be less than the dipolar spin lattice relaxation time of the protons T_{1d} . The quadrupole resonance frequencies of the pure pesticides samples have been measured using the Wilks Superregenerative Spectrometer (a basic schematic of this spectrometer is shown in Fig. 13); so the irradiation frequency of H_{1B} is precisely known.

The sample is moved back into the high field after τ_0 seconds of irradiation in the zero field region. The remaining proton (A) nuclear order is reformed as a magnetization along the high field. This magnetization is immediately measured by applying a 90° rf pulse at the resonant frequency of the proton nuclei (38.3 MHz). The rf pulse is sufficiently intense to rotate the nuclei through 90° in a time, t_w , before spin flips can dephase the magnetization,

$$\gamma_A H_{1A} t_w = \frac{\pi}{2},$$

where

$$t_w < T_2.$$

After the 90° pulse the nuclear magnetization precesses in a plane perpendicular to H_0 , the d.c. field, and induces a voltage in the

Figure 13

Basic schematic of the Superregenerative Spectrometer.

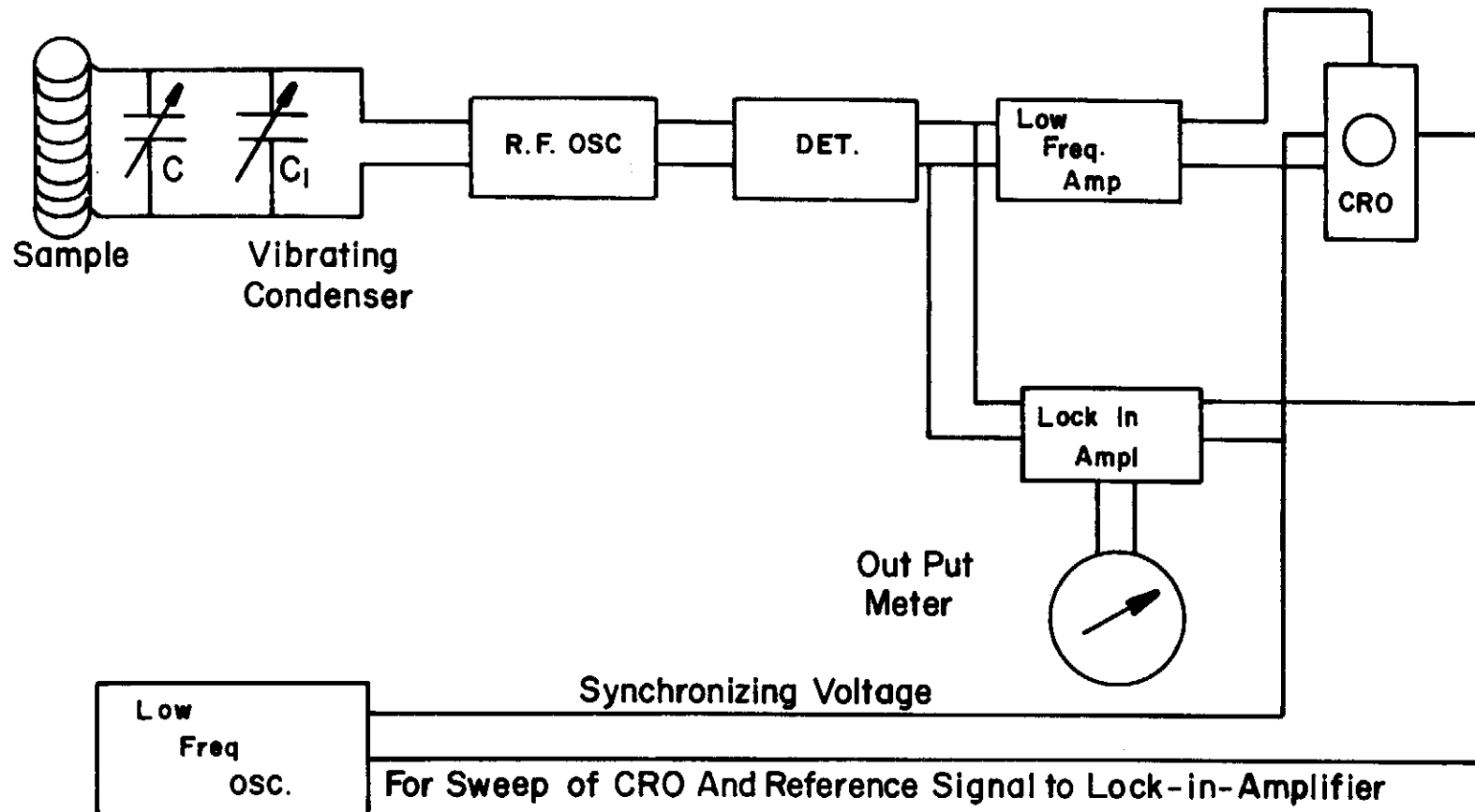

A-coil. Voltage induced by the free induction decay (10 to 100 microvolts) and thermal noise voltage (1 microvolt) are amplified by rf amplifiers to approximately 0.1 to 1 volt. The rf voltage is then detected, filtered, and amplified by the LF amplifier. The output of the LF amplifier is fed to the Biomation ADC and then on to the signal averager, the output of which is displayed on the CRT. After each cycle, the nuclear magnetization was zeroed by a series of 90° pulses, before the start of the next cycle. The Double Resonance effect appears as a decrease in the FID signal from the initial value before the start of the Double Resonance cycle.

vi) Sample Preparation, Extraction and Concentration

Since the pesticides are hydrophobic compounds, in order to mix a known amount of pesticide in a known amount of water the mixture was stirred for ten minutes with a magnetic stirrer, the method suggested by Lyons and Salman.⁵ The extraction and concentration procedures used were similar to that reported by Thompson et al,¹ except bromoform was used as the solvent in case of chlorinated pesticides and chloroform in case of non-chlorinated carbamate pesticides. These solvents were chosen because they are insoluble in water. Starting with one liter of tap water, spiked with a known amount of pesticide, the sample was extracted by adding 10 ml of either CHBr_3 or CHCl_3 and shaking vigorously and then allowing sufficient time for complete phase separation. This procedure was repeated four times. The extracted sample was concentrated in a Kuderna-Danish (K-D) evaporator in a nitrogen atmosphere. The standards were mixed with CHBr_3 or CHCl_3 and the reference data was taken for later comparison with the actual samples.

CHAPTER III
DATA AND RESULTS

The measurements and the raw data are given for a typical pesticide, carbanolate, as representative of the data taken for the various pesticide samples studied. Figure 14 is the NQR spectrum of ^{35}Cl in pure carbanolate at room temperature using the Wilks Superregenerative Spectrometer. The signal is quite strong, even at room temperature, suggesting that it might be possible to detect low concentrations by the Double Resonance technique. The spectrum indicates the central quadrupolar frequency and the side bands separated by the quench frequency, which is characteristic of the Superregenerative Spectrometer. As is indicated under research procedures, Section v, Chapter II, the precise quadrupole frequency of the compound is necessary to achieve full Double Resonance effect by irradiating the sample in the B-position at the resonance frequency of the quadrupolar nucleus (B). The quadrupolar T_{1Q} and T_{2Q} of this sample were measured using the Bruker NMR Spectrometer. Also measured are the high field T_1 and the dipolar relaxation time T_{1d} for protons in the sample. The above is summarized in Table I. Figure 15 is the room temperature proton FID signal of carbanolate at 61 MHz using the Pulsed Spectrometer facility in Prof. Doane's laboratory at Kent State University. Even though the pulse and dead time was about 12 μs , the signal is still very strong and decays in about 40 μs . Figure 16 is the Fourier transform representation of the carbanolate proton FID signal.

Short quadrupolar T_1 is helpful in obtaining a larger effect on the proton in the Double Resonance experiment. This is given by the relation:

$$\frac{1}{T_{1p(\text{eff})}} = \frac{1}{T_{1p}} + \frac{1}{T_{1Q}}$$

If T_{1Q} is short, we can neglect $\frac{1}{T_{1p}}$. This condition seems to obtain in the above case.

Figure 14

NQR spectrum of ^{35}Cl in pure carbanolate.

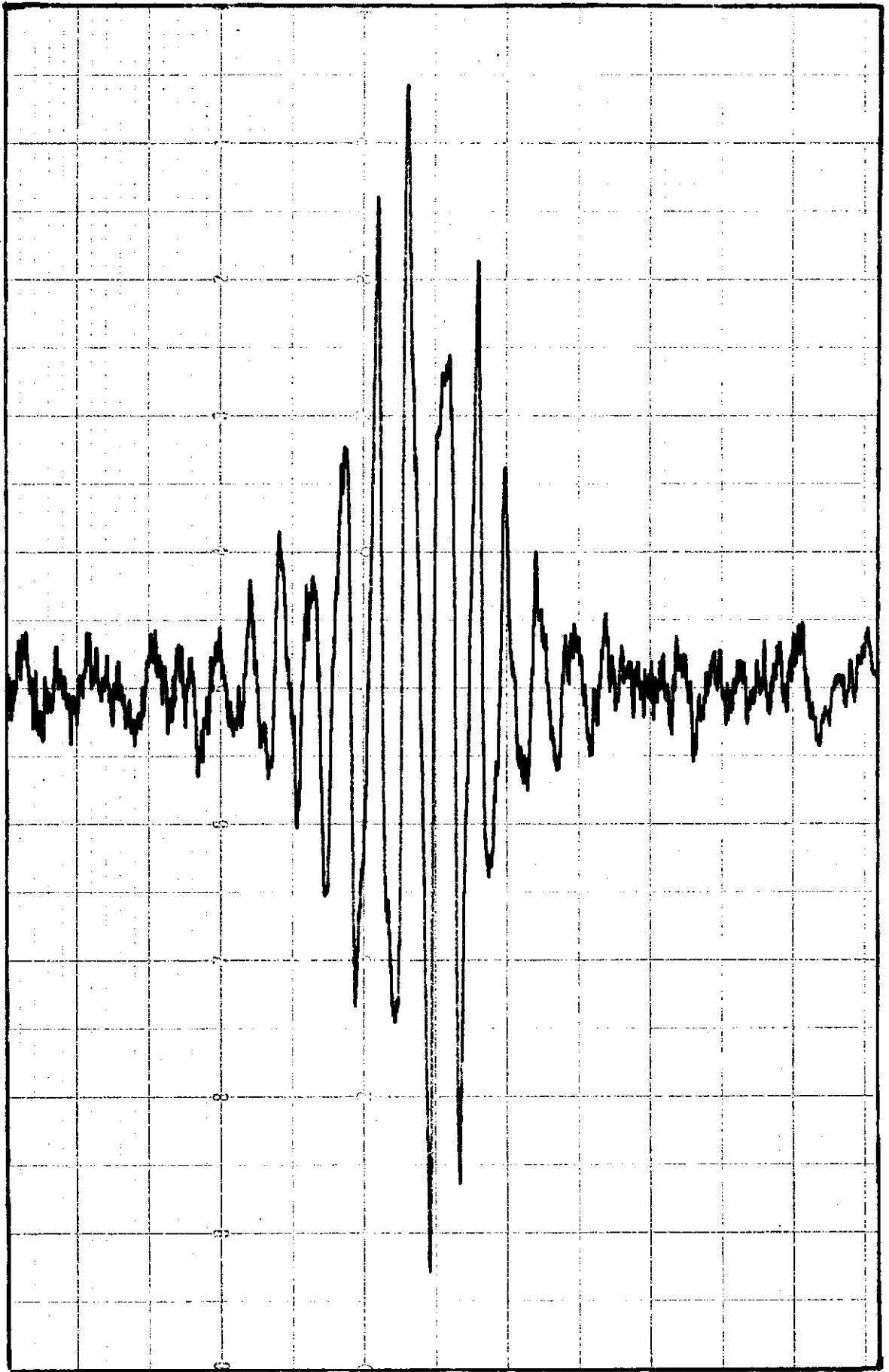
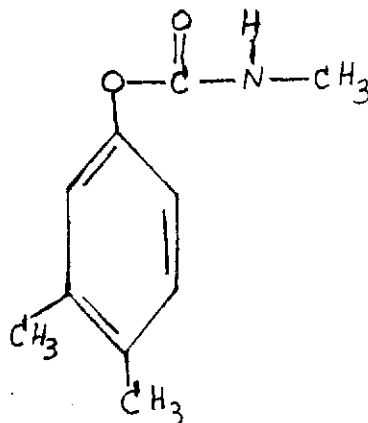

TABLE I

QUADRUPOLE RESONANCE FREQUENCIES, ν_Q , AND THE VARIOUS
RELAXATION TIMES OF CARBANOLATE

Chemical Formula:



^{35}Cl (ν_Q): 35.115 MHz ; ^{37}Cl (ν_Q): 27.675 MHz

$T_{1Q} = 29$ ms ; $T_{2Q} = 212$ μ s

^1H : $T_1 = 22$ seconds ; $T_{1d} = 18$ seconds

Figure 15

Proton FID signal of carbanolate at room temperature
and at a frequency of 61 MHz.

Signal Amplitude (Arbitrary Units)

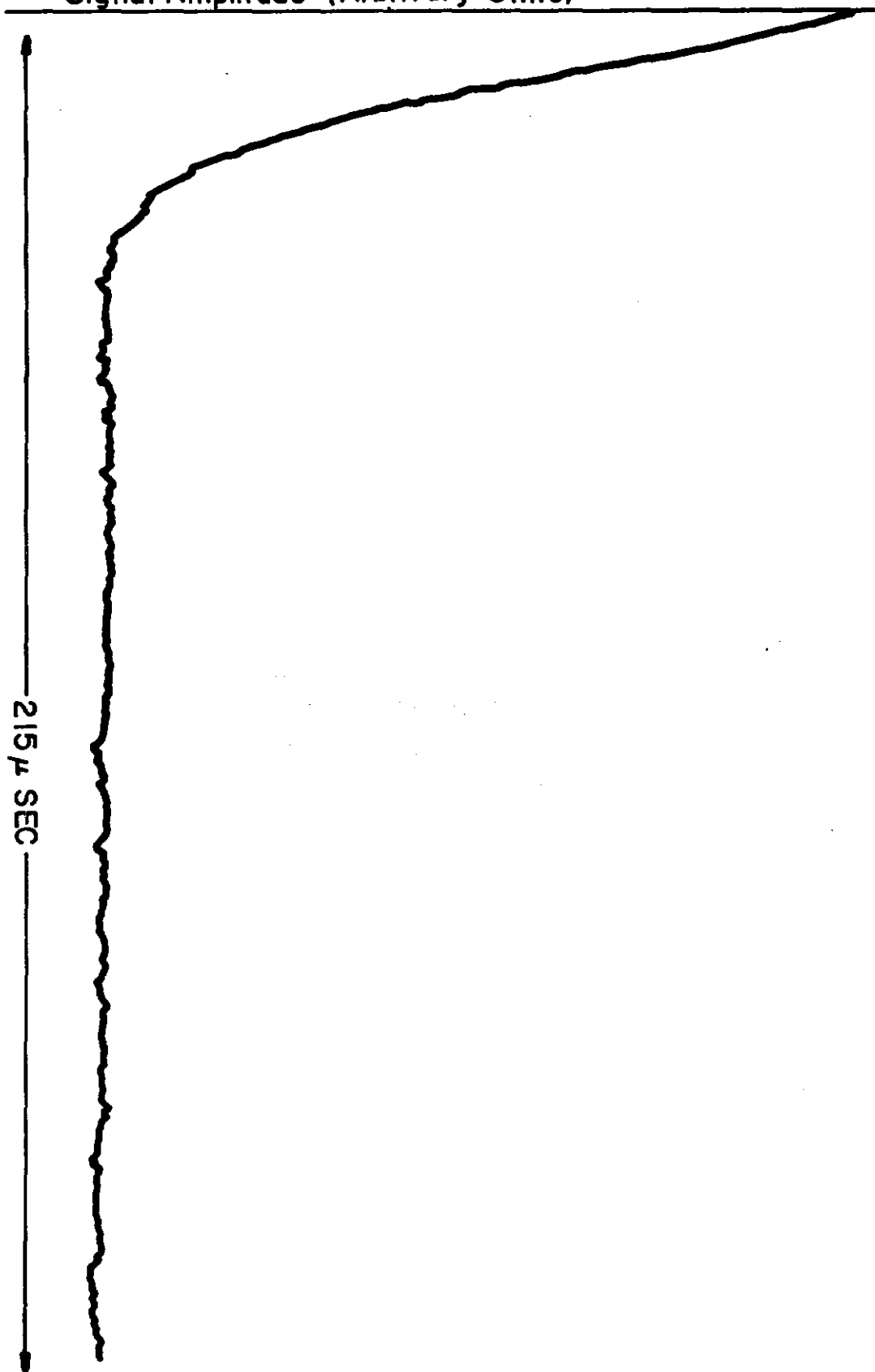

Figure 16

Fourier transform representation of carbanolate
proton FID signal.

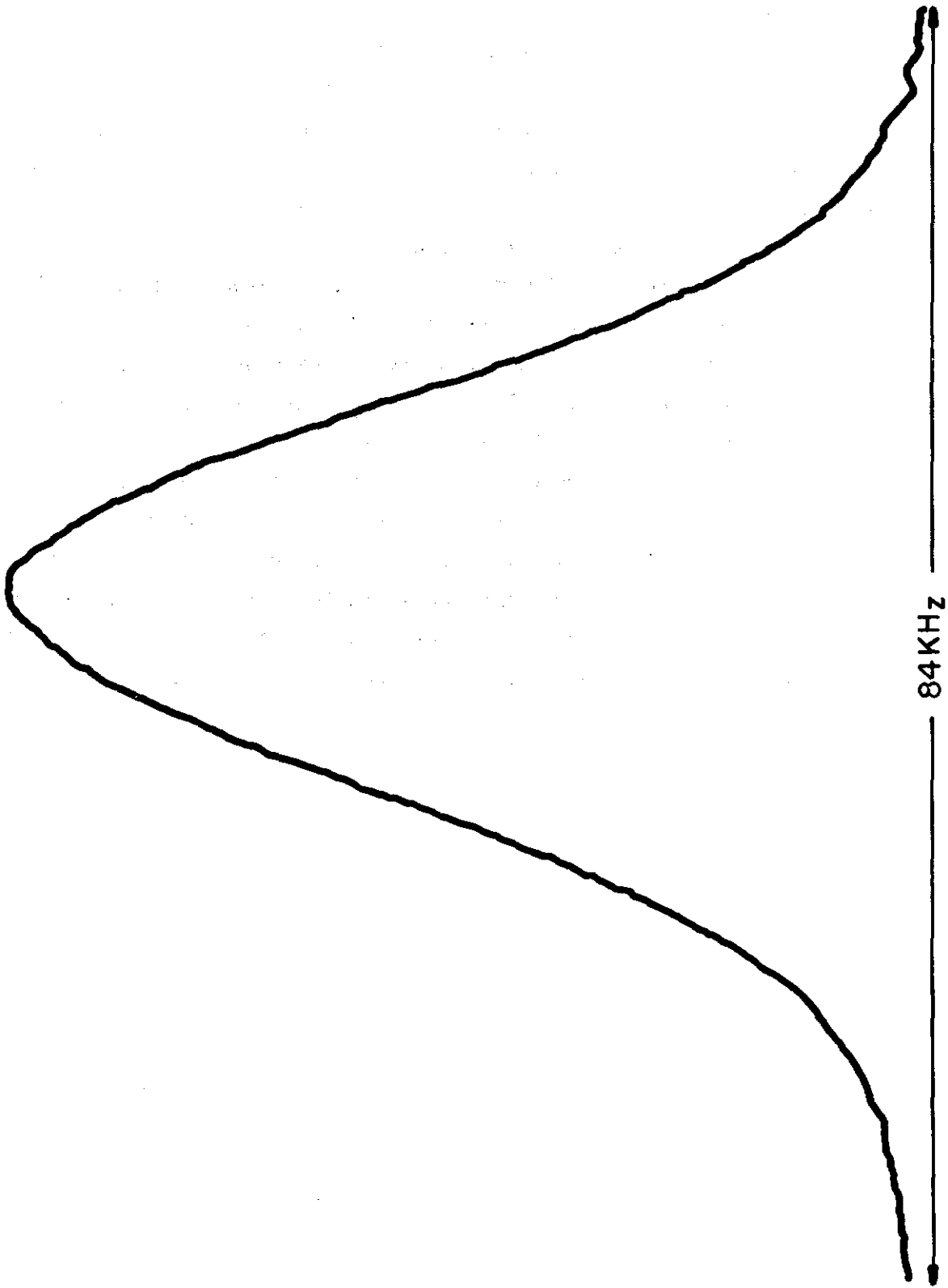

Figure 17 shows the Double Resonance effect in carbanolate at a concentration of 100 ppm. The Double Resonance effect of chlorine is the difference in heights of the two FID signals shown at a suitable point of reference on the horizontal time scale as indicated by the arrows. The signal in the top photograph is obtained with the sample returned to the A-position without rf irradiation in the B-position and the other after irradiation of the sample at the quadrupolar frequency in the zero field position. The design and construction details of the Double Resonance Spectrograph and preliminary results on pesticides have been reported by Osredkar, Kadaba, Harvey and Bhagat.⁶

The use of a commercial data acquisition and processing system featuring the A/D converter, signal averaging processor with built in fast Fourier transformation hardware can greatly improve the sensitivity. This unit was available for a short time and was used in conjunction with an X-Y recorder interface to obtain data on the same compound at concentration levels of 1 ppm, 100 ppb and 20 ppb. The recorded signals are shown respectively in Figures 18, 19 and 20.

Table II gives the minimum concentrations of the following pesticides that have been possible to detect with the spectrometer: carbanolate, barban, CIPC, atrazine, simazine, heptachlor epoxide and aldrin.

Figure 17

Double Resonance effect of chlorine in carbanolate at a concentration of 100 ppm. The effect is the difference in heights of the two FID signals shown.

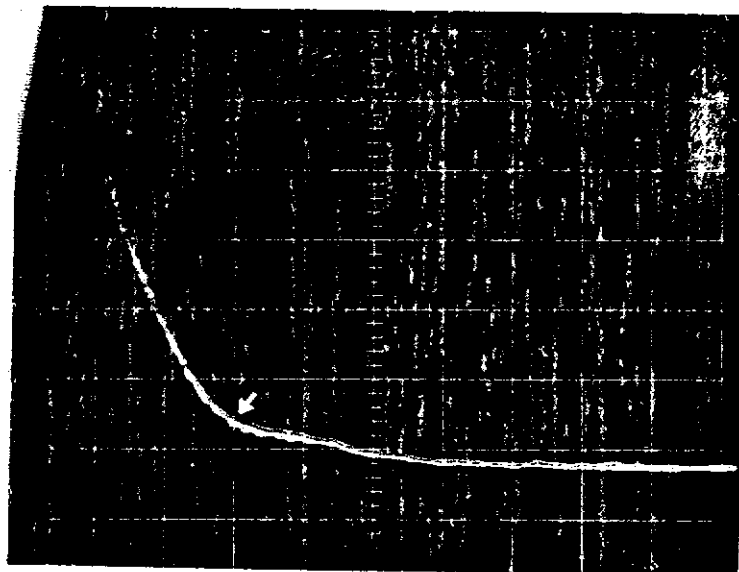
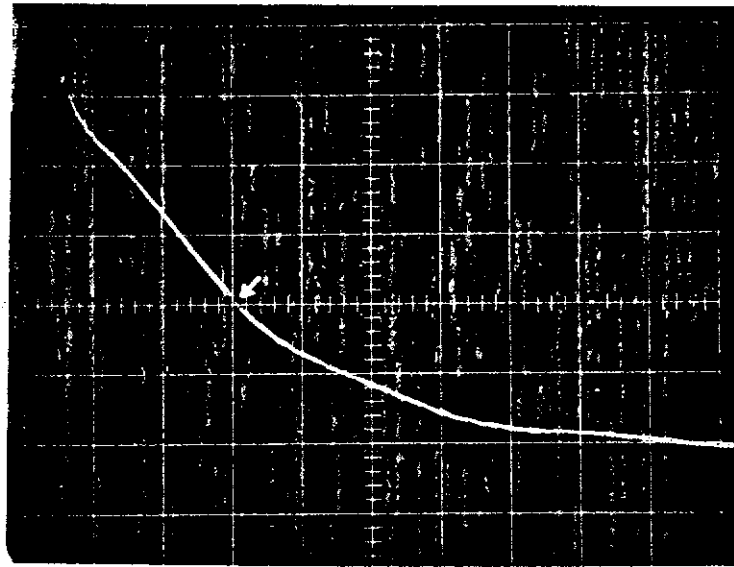

Figure 18

Fourier Transform representation of the chlorine signal of carbanolate after signal averaging (concentration 1 ppm).

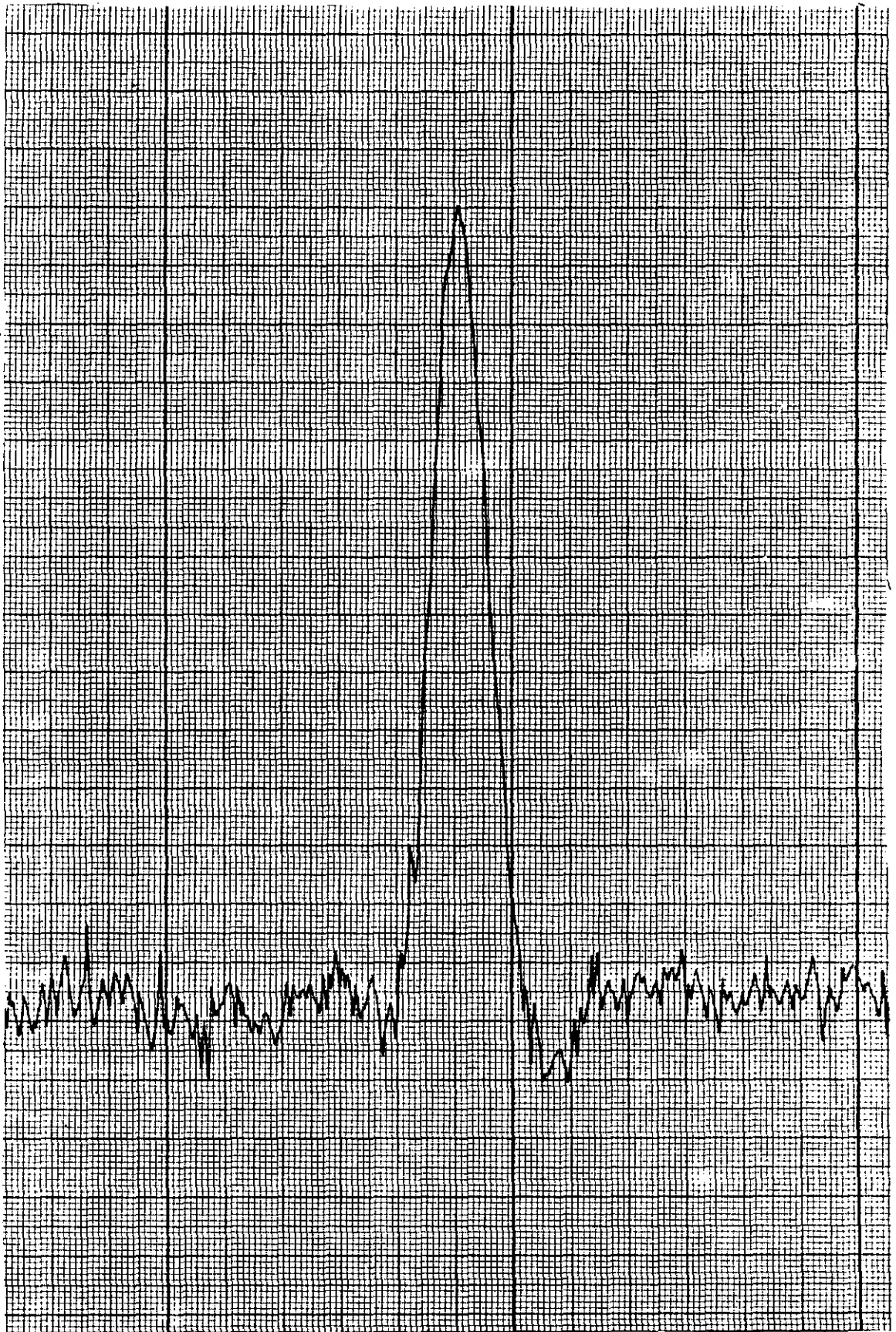

Figure 19

Fourier Transform representation of the chlorine
signal of carbanolate after signal averaging
(concentration 100 ppb).

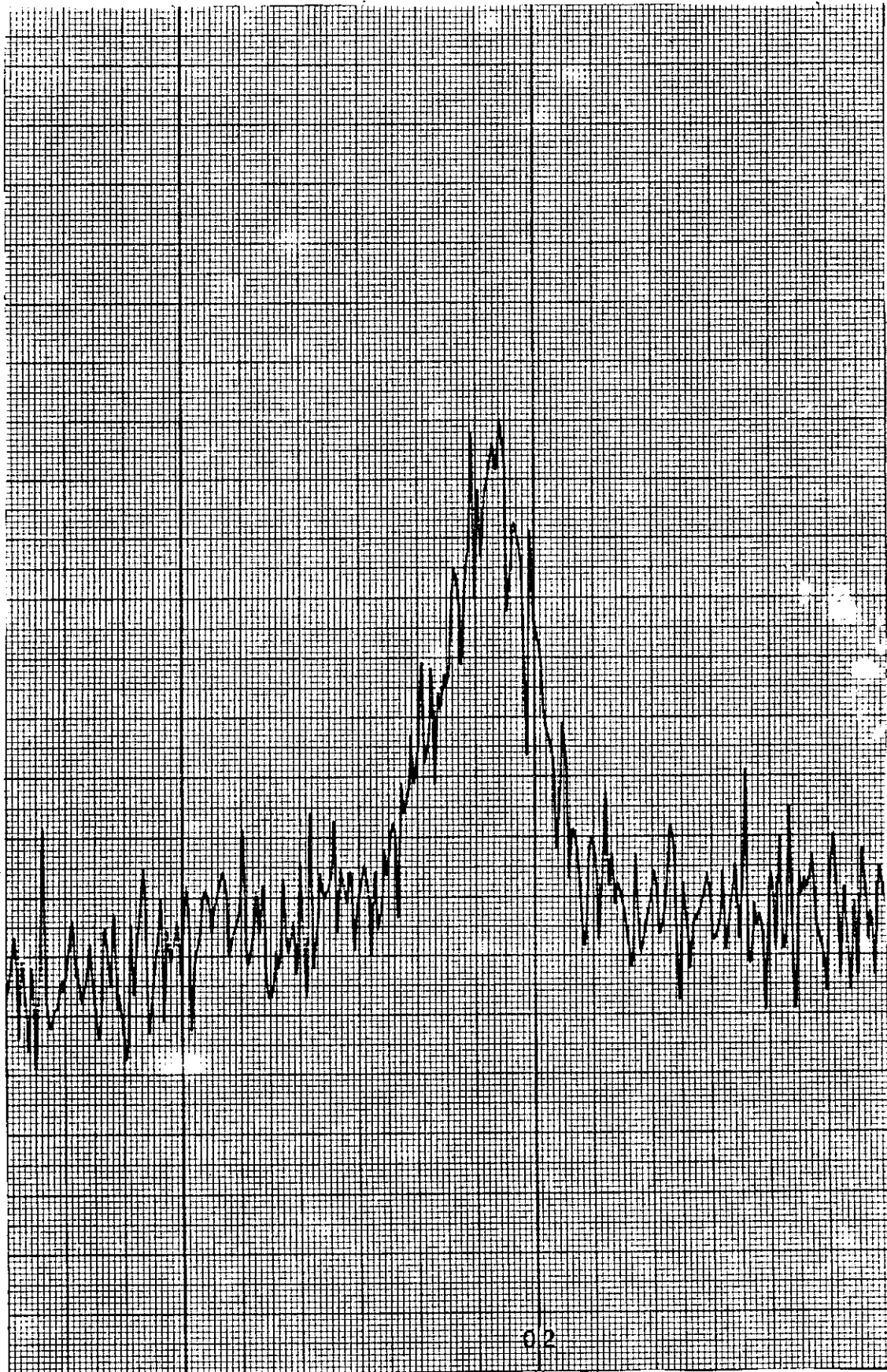

Figure 20

Fourier Transform representation of the chlorine
signal of carbanolate after signal averaging
(concentration 20 ppb).

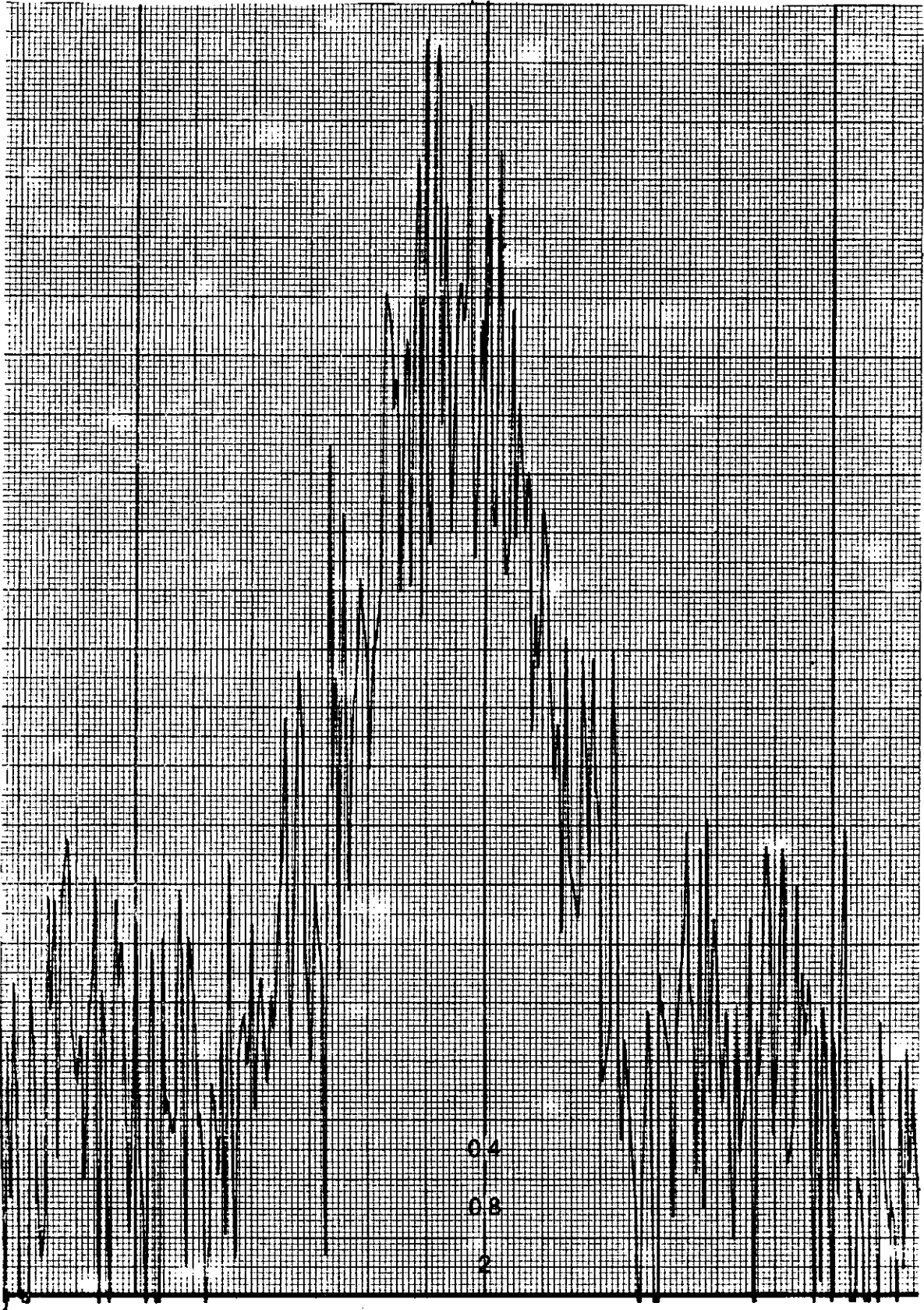

TABLE II

MINIMUM DETECTABLE CONCENTRATIONS OF THE PESTICIDES TESTED

Compound	Chemical Formula	Concentration (ppb)
Carbanolate		20
Barban		20
CIPC		25

TABLE II (continued)

Compound	Chemical Formula	Concentration (ppb)
Atrazine		100
Simazine		100
Heptachlor epoxide		15
Aldrin		15

CHAPTER IV

CONCLUSIONS

What is accomplished in the project is the design and construction of a sophisticated and sensitive spectrometer and its feasibility for the detection of certain chlorine containing pesticides. With sophisticated signal averaging techniques and standard extraction and concentration procedures the Nuclear Double Resonance Spectrograph that has been developed in this project has been able to detect low concentration of pesticides in water samples.

The sensitivity of the present technique is less than that of electron capture gas chromatography but has an advantage over the latter technique in detecting directly heat-labile compounds using below ice temperatures. Most carbamate pesticides cannot be analyzed directly by gas chromatography unless conversion to more suitable derivatives is carried out, because they are thermally unstable. In the present technique, clean-up and separation procedures need not be elaborate in some cases. For example, fats and oils in sample extracts do not interfere with the measurements. Application to the analysis of organochlorine and triazine pesticides in waste water (industrial effluents) is possible with this technique provided the concentration of these compounds is between 10 to 100 micrograms per liter. The instrument in its present form cannot be used as a routine analytical tool. Further improvement in sensitivity is possible by using liquid nitrogen-cooled, ferrite-cored electromagnet, increasing the polarizing field and going to a two-magnet system.

Apart from the application for which the instrument has been utilized in this project, the Nuclear Double Resonance technique can be used to study the electronic structure of molecules, and hence can be used for structure related studies of compounds.

REFERENCES AND BIBLIOGRAPHY

1. See, for example:

Thompson, J. F., Reid, S. J. and Kantor, E. J., "A Multiclass, Multi-residue Analytical Method for Pesticides in Water," *Arch. Environm. Contam. Toxicol.*, 6, 143-157 (1977).

Teasley, J. I. and Cox, W. S., "Methods for Extracting Insecticides from Soil," *J. Agr. Food Chem.*, 14, 519-520 (1966).

Kawahara, F. K., Eichelberger, J. W. and Reid, B. H., "Semi-automatic Extraction of Organic Materials from Water," *Journal WPCF*, 39, 572-578 (1967).

2. Hartmann, S. and Hahn, E. L., "Nuclear Double Resonance in the Rotating Frame," *Phys. Rev.*, 128, 2042-2053 (1962).
3. Slusher, R. E. and Hahn, E. L., "Sensitive Detection of Nuclear Quadrupole Interactions in Solids," *Phys. Rev.*, 166, 332-345 (1968).
4. A. Messiah, *Quantum Mechanics*, Vol. II, (John Wiley and Sons, New York, 1962), p. 740; R. Slusher, Ph.D. thesis (unpublished), University of California (1966), Chapter III.
5. E. T. Lyons and H. A. Salman, "Development of Analytical Procedures for Determining Chlorinated Hydrocarbon Residues in Waters and Sediments from Storage Reservoirs," REC-ERC-72-15, PB210839 (1972).
6. Osredkar, R., Kadaba, P. K., Harvey, J. R. and Bhagat, P. K., "Application of Nuclear Double Resonance Technique to Detection of Certain Pollutants in Water," *Bull. Am. Phys. Soc.*, 23, 587 (1978).

Related Bibliography

7. Chen, J. T. and Benson, W. R., "Characteristic Infrared Absorption Spectra and Frequencies of Carbamate Pesticides," *J. Assn. of Official Analytical Chemists*, 49, 412-452 (1966).
8. Burke, J. A., Mills, P. A. and Bostwick, D. C., "Experiments with Evaporation of Solutions of Chlorinated Pesticides," *Ibid.*, 49, 999 (1966).
9. Finocchiaro, J. M. and Benson, W. R., "Thin Layer Chromatography of Some Carbamate and Phenylurea Pesticides," *Ibid.*, 50, 888-896 (1967).
10. Chiba, M. and Morley, H. V., "Studies of Losses of Pesticides During Sample Preparation," *Ibid.*, 51, 56 (1968).

11. Benson, W. R., "The Literature of Pesticide Chemistry - Part II," Ibid., 54, 192-201 (1971).
12. Lamar, W. L., Goerlitz, D. F. and Law, L. M., "Identification and Measurement of Chlorinated Organic Pesticides in Water by Electron Capture Gas Chromatography," Geological Survey Water-Supply Paper, 1917-1918 (1965).
13. Goldberg, M. C., De Long, L. and Sinclair, M., "Extraction and Concentration of Organic Solutes from Water," Anal. Chem., 45, 89 (1973).
14. Garrison, A. W., Keith, L. H. and Alford, A. L., "Confirmation of Pesticide Residues by Mass Spectrometry and NMR Techniques," Advances in Chemistry Series, 111, 26-54 (1972).
15. Webb, R. G., Garrison, A. W., Keith, L. H. and McGuire, J. M., "Current Practice in GC-MS Analysis of Organics in Water," EPA-R2-73-277 (August 1973).
16. Thurston, Jr., A. D., "Liquid Chromatography of Carbamate Pesticides," EPA-R2-72-079 (October 1972).
17. Benson, W. R., Lombardo, P., Egry, I. J., Ross, Jr., R. D., Barron, R. P., Mastbrook, D. W. and Hansen, E. A., "Chlordane Photoalteration Products: Their Preparation and Identification," Agricultural and Food Chemistry, 19, 857-862 (1971).

